

LEVER HOIST

**FREE
SPARE SET
OF LATCHES**

Excludes
1/4 Ton Model

Features

- All-steel construction
- Aluminum construction (1/4 Ton Model)
- Long lasting powder coat finish
- Steel handle with rubber grip
- Minimal load lifting effort
- Weston-Style brake system with twin pawl design
- 100% load tested grade 80 alloy chain
- Fully-enclosed gearing
- Load sheave bearings
- Forged alloy steel hooks
- Heavy-duty latches
- Carrying bag (1/4 Ton Model)

Standards - CE, ASME B30.21, AS1418.2

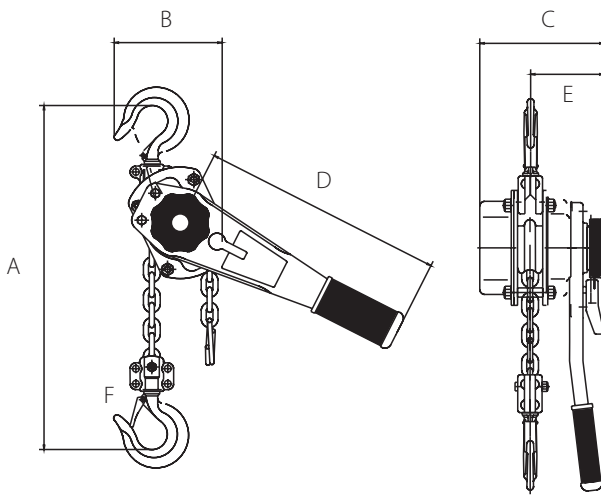

OZIND025-LH

OZIND075-LH

	OZIND025-LH	OZIND075-LH	OZIND150-LH	OZIND300-LH	
Capacity (tons)	0.25	0.75	1.5	3	
Effort to Lift S.W.L (lbs)	44	40	66	88	
Falls of Chain	1	1	1	1	
Load Chain Diameter (mm)	4x12	6x18	8x24	10x30	
Product Dimensions (in)	A	9.45	13.38	16.14	
	B	3.62	5.31	5.91	8.27
	C	3.86	6.02	6.89	7.83
	D	6.3	12.2	16.34	16.34
	E	2.36	3.62	3.98	4.45
Hook-opening, Upper & Lower	F	0.83	1.1	1.26	1.5
Net Weight (lbs)	4	12	20	36	

***Standard Lift: 5, 10, 15 and 20 ft.**

***.25 T Models Standard Lift: 5 and 10 ft.**

We also do custom rigging

*Dimensions are for reference only and subject to change without notice.



WARNING
CANCER AND REPRODUCTIVE HARM
 Some products may contain chemicals known to the state of California to cause cancer, or birth defect or reproductive harm.
www.P65Warnings.ca.gov

