

## ELECTRIC BUILDER'S HOIST



### Features

- Lightweight and compact design for convenient mounting
- Built-in safety features and easy control of lifting for a wide range of applications
- Automatic shut-off when rope reaches limit arm
- Dynamic and mechanical brake provides instant and safe braking
- Upper and lower limit switches for additional safety
- Sensor arm for motor shut-off to prevent reverse winding
- Galvanized wire rope with 360-degree weighted hook includes safety latch
- Quick release pendant and power cords
- Standard 115V power source-compatible
- Wireless remote control for ease of use (Model OBHW600 only)
- Emergency UP / DOWN control switch (Model OBHW600 only)



### Standards - CE

### Specs

|                            | OBH500      | OBHW600     | OBH1000     |
|----------------------------|-------------|-------------|-------------|
| Capacity - Full Drum (lbs) | 500         | 600         | 1000        |
| Motor Voltage              | 115/1/60    | 115/1/60    | 115/1/60    |
| Speed (fpm)                | 75          | 52          | 37          |
| Motor (HP)                 | 1.74        | 2           | 2.41        |
| Motor KW                   | 1300W/17.5A | 1500W/12.5A | 1800W/15.5A |
| Lifting Height (ft)        | 90          | 90          | 90          |
| Wire Rope (in)             | 3/16        | 3/16        | 1/4         |
| Gross Weight* (lbs)        | 54          | 49          | 73          |
| Power cord length (ft)     | 15          | 15          | 15          |
| Pendant length (ft)        | 65          | n/a         | 65          |
| Full Load (AMPS)           | 17.5        | 12.5        | 15.5        |
| Duty Cycle (min)           | 15 (25%)    | 15 (25%)    | 15 (25%)    |

\*Includes lower hook, power and pendant cable / \*Includes lower hook and power cable (OBHW600)  
**100 ft. pendant length available**

**500, 600, 1000 LBS**

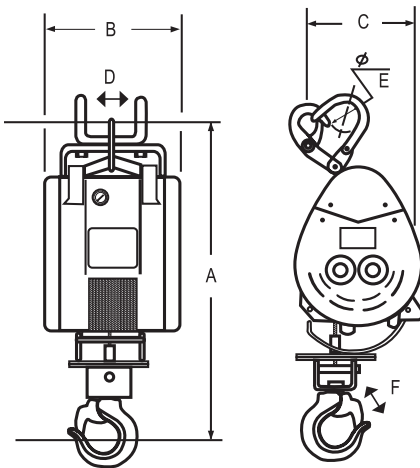

|        |                    | OBH500 | OBHW600 | OBH1000 |
|--------|--------------------|--------|---------|---------|
| A (in) | Height             | 26.77  | 26.77   | 28.50   |
| B (in) | Width              | 9.50   | 9.50    | 10.50   |
| C (in) | Depth              | 7.88   | 9.06    | 12.00   |
| D (in) | Hanger Inner Width | 4.50   | 4.50    | 5.50    |
| E (in) | Hanger Opening     | 2      | 2       | 2       |
| F (in) | Hook Opening       | 1.62   | 1.62    | 1.50    |

\*Dimensions are for reference only and subject to change without notice.

OBHW600



**WARNING**  
**CANCER AND REPRODUCTIVE HARM**  
 Some products may contain chemicals known to the state of California to cause cancer, or birth defects or reproductive harm.  
[www.P65Warning.ca.gov](http://www.P65Warning.ca.gov)

## MOUNTING AND LIFTING SOLUTIONS

### Mounting Arm Bracket (Pipe-Mount and Wall-Mount)

- Long last powder coat finish
- Solid mounting bracket
- Portable / Light Weight
- Quick mount
- Made in USA

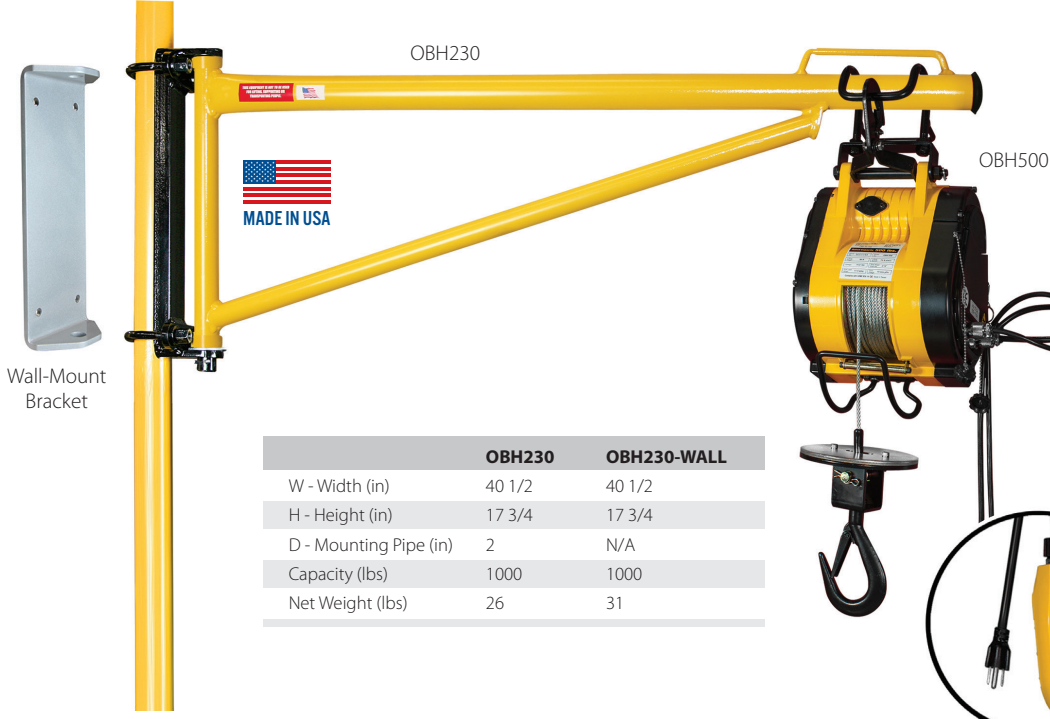

|                        | OBH230 | OBH230-WALL |
|------------------------|--------|-------------|
| W - Width (in)         | 40 1/2 | 40 1/2      |
| H - Height (in)        | 17 3/4 | 17 3/4      |
| D - Mounting Pipe (in) | 2      | N/A         |
| Capacity (lbs)         | 1000   | 1000        |
| Net Weight (lbs)       | 26     | 31          |

Pipe Not Included

OBH500

OBH500

Wall-Mount Bracket

Pipe Not Included



OZ05PBTA-OBH  
**Trolley with OBH Hanger**  
Contact us for more information.

Refer to OZ05PBTA dimensions on page 13



OZGBT-OBH  
**Geared Trolley with OBH Hanger**  
Contact us for more information.

Refer to OZ1GBT dimensions on page 15

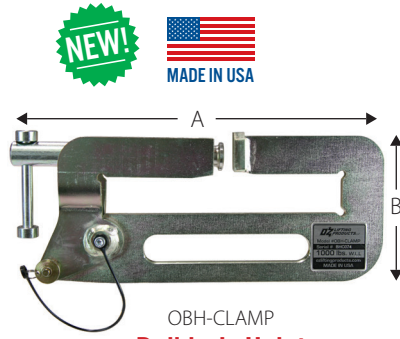

OBH-CLAMP  
**Builder's Hoist Beam Clamp**

| OBH-CLAMP             |       |
|-----------------------|-------|
| A - Width (in)        | 13.5  |
| B - Height (in)       | 5.375 |
| Max flange width (in) | 8     |
| Capacity (lbs)        | 1000  |
| Net Weight (lbs)      | 8     |

Contact us for more information.



OZBAG3  
**Hoist Bucket**  
Contact us for more information.

Hoist bucket rated at 150 lbs.