

# ROVSUN

## Commercial Steam Table Food Warmer with lockable wheels

Thanks for purchasing our electric food warmer. Please read this manual carefully, paying particular attention to the safety regulations outlined below, before installing and using it for the first time. If you have any problem, please feel free to contact us, we will solve the problem for you after confirmation.

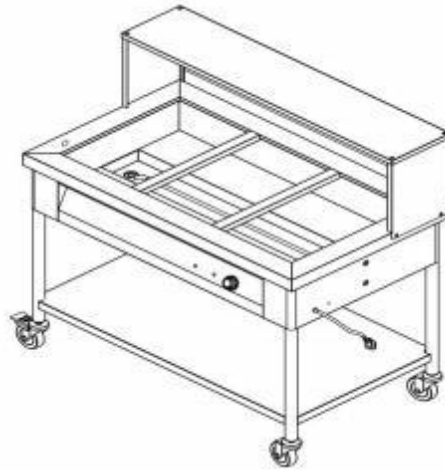

### 1. Overview of parts

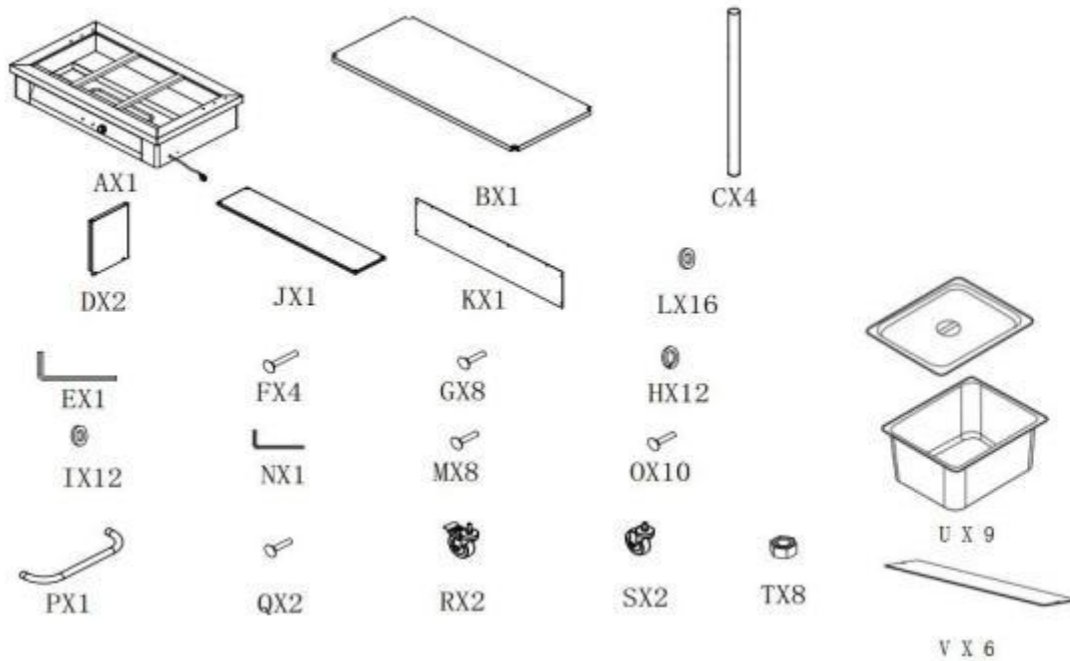

A:Base Assembly - 1 pcs B:Under shelf - 1 pcs C:Legs - 4 pcs D: Support for over shelf - 2pcs  
 J: Over shelf - 1 pcs K: Acrylic Sneeze Guard - 1 pcs L: A nuts - 16 pcs H: B nuts - 12 pcs I: C  
 nuts - 12pcs T: D nuts - 8pcs F: A screws - 4 pcs G: B screws - 8 pcs M: C screws - 8 pcs O:  
 D screws - 10 pcs Q: E screws - 2 pcs P: Handle - 1 pcs R: Lockable wheels - 2 pcs S:  
 Wheels - 2 pcs U: Food pan+lid - 9 sets V: Holder for food pan - 6 pcs

## 2.Specification

Power:	110V , 1500W
Temperature:	30-92°C ( 86°F - 197°F)
Food pan size:	1/3x150mm ( 325x176x150mm )
Overall size:	1150x673x850mm
Material:	Stainless steel, Acrylic

## 3.Assembly Instruction

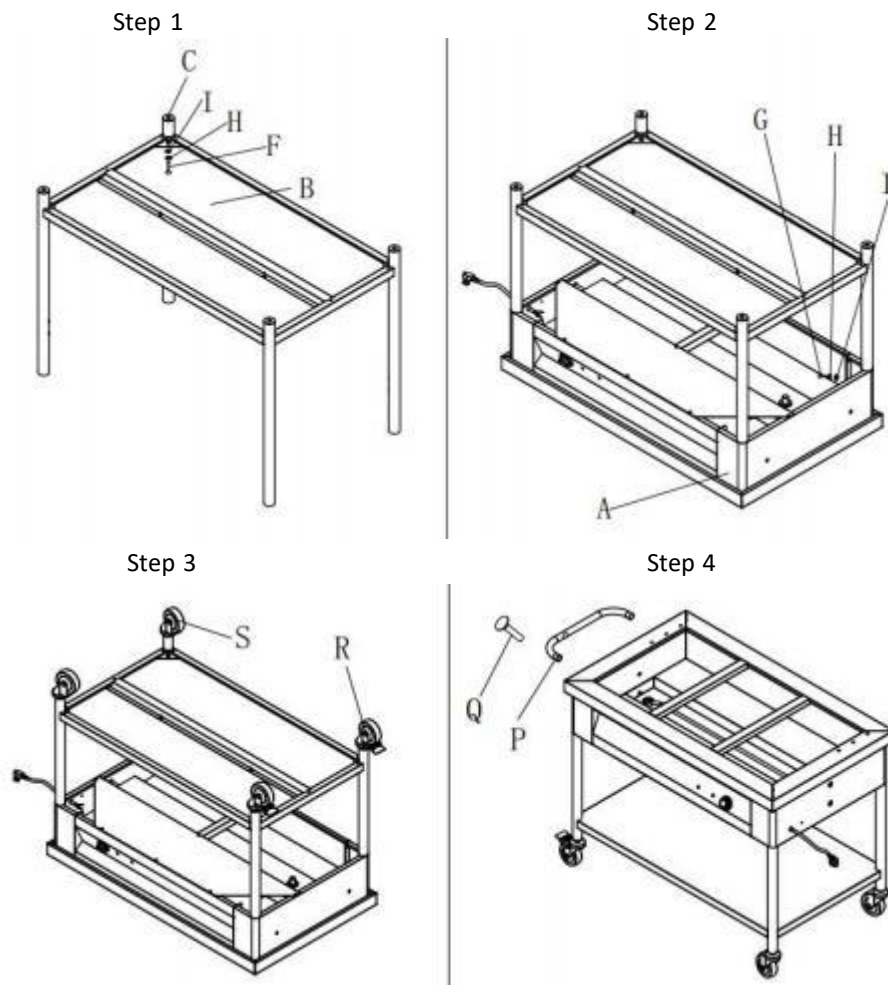

Step 5

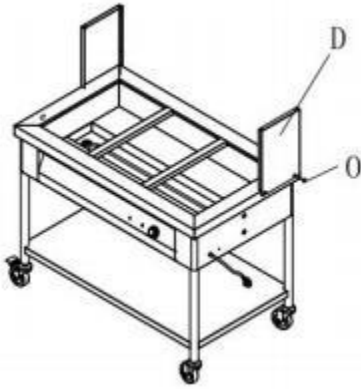

Step 6



Step 7



step 8

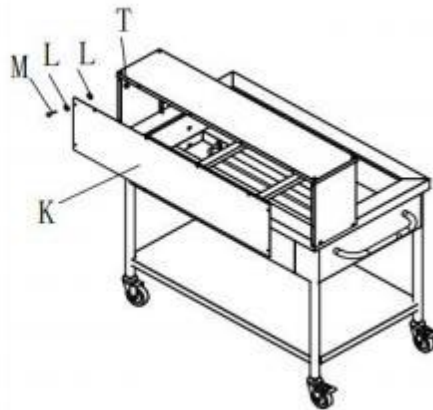

## 4. Operating Instructions

The unit must be connected to a power point with compatible power rating

1. **Peel off protective film.** Clean the device thoroughly before using for the first time. Before cleaning or repair works make sure the device has been disconnected from power socket and cooled down.



2. Make sure drain under the base is closed before fill with HOT tap water. Please note MAX and MIN water level.



3. Put holder for food pan on well before put food pan.
4. Turn well to high heat, allow unit 15-20 minutes to preheat.
5. Place precooked food (minimum 70°C/160°F) in food pans, place in the wells and cover with lids.
6. Connect the device to a suitable single mains socket. Adjust the temperature dial (30°C-100°C/86°F-212°F)
7. Maintain water level in pan throughout the day, recommended to check from waterline device outside.

## 5.Cleaning steps

- (1) Before beginning with cleaning works make sure the device has been disconnected from power socket (pull the power plug) and has cooled down.
- (2) Do not use any acid agents and make sure no water ingresses the device.
- (3) Wipe off thoroughly with a mild cleaning agent and a soft, damp cloth, dry with a soft cloth.
- (4) After the cleaning procedure, please using a soft and dry cloth to wipe dry.

## 6.Safety instructions

- (1) Only use the appliance for the intended purpose it was designed for as described in this manual.
- (2) The manufacturer is not liable for any damage caused by incorrect operation and improper use.
- (3) Never attempt to open the housing of the appliance by yourself.
- (4) Do not touch the plug with wet or damp hands.

## SAFETY WARNINGS !

ROVSUN Electric Steam Tables are designed, built, and sold for commercial use and should be operated by trained personnel only. Clearly post all CAUTIONS, WARNINGS, and OPERATING INSTRUCTIONS near each unit to ensure proper operation and to reduce the chance of personal injury and/or equipment damage.

**WARNING:** Do not store or use gasoline or other flammable vapors and liquids in the vicinity of this or any other appliance. Keep the area free and clear of combustible

materials.

**WARNING:** Improper installation, adjustment, alteration, service, or maintenance can cause property damage, injury, or death. Read the Installation, Operating, and Maintenance Instructions thoroughly before installing or servicing this equipment.

**CAUTION:** These models are designed, built, and sold for commercial use only. If these models are positioned so the general public can use the equipment, make sure all cautions, warnings, and operating instructions are clearly posted near each unit so that anyone using the equipment can use it correctly and not injure themselves or the equipment.

**CAUTION:** Make sure food product has been heated to the proper food-safe temperature before placing in unit. Failure to heat food product properly may result in serious health risks. This unit is for holding preheated food product only.

**CAUTION:** Locate unit in an area that is convenient for use. The location should be level and strong enough to support the weight of the unit and contents.

**WARNING:** Do not touch the interior or exterior of the heating wells during operation.

**WARNING:** Use protective gloves when adding a pan to a heated well to prevent burns from steam or touching the hot surface.