



2022+ Ford Maverick Stealth Grille Light Mount

CONTENTS		TOOLS
QTY	DESCRIPTION	7mm, 10mm & 15mm sockets and/or wrenches
2	Grille Light Mount (One Left & One Right)	T30 Torx Bit
1	Middle Connecting Bracket	Plastic Clip Removal Tool
6	Carriage Bolt w/ washers & nut	

Installation Instructions

Bumper Cover Removal

The factory manual suggests that you remove the front wheels prior to removing the front bumper cover; this is not entirely necessary but could allow for easier access for the rest of the bumper cover removal.

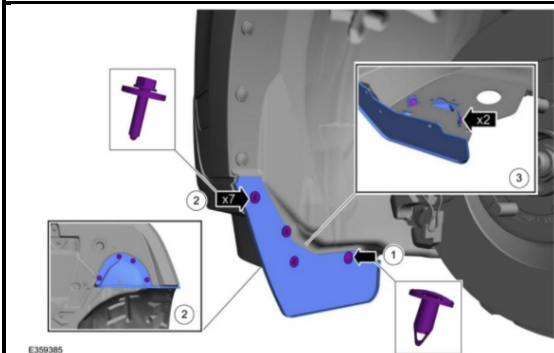

1. Remove the plastic air deflectors. This requires a 7mm socket for the screws and a small pry tool for the clips. To remove the clips, you must first raise the inner pin. With the inner pin raised or removed, you can then remove the outer pin (see 1 below). This step applies to both sides.

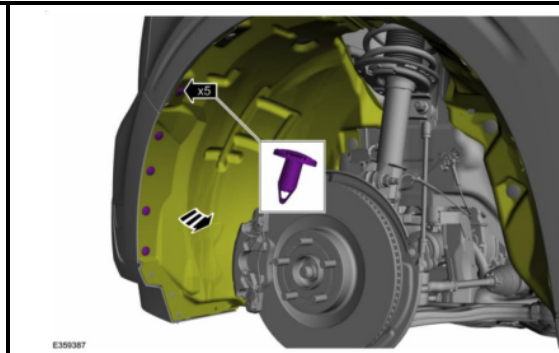

2. Remove the 5 push pins that secure the fender liner to the bumper cover and fender. Applies to both sides.

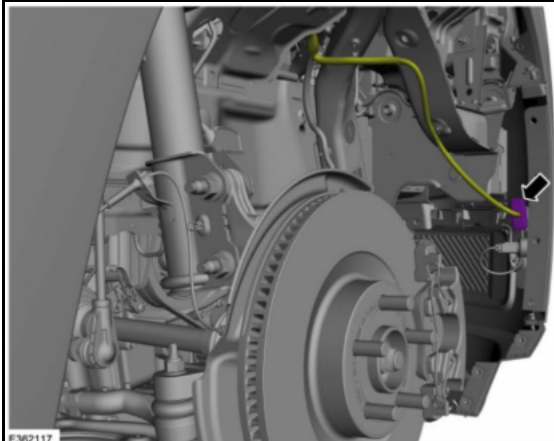

3. Disconnect the front bumper wiring harness. This is located on the passenger side and can be accessed from behind the fender liner

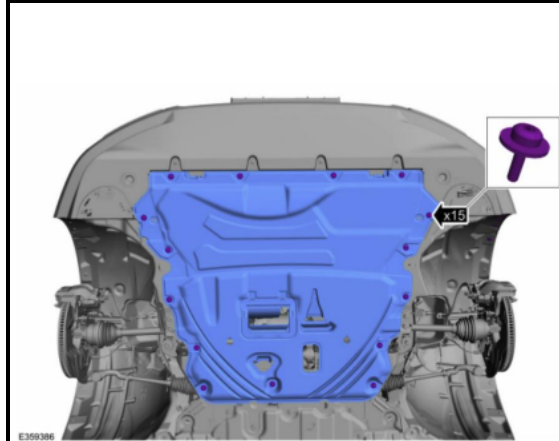

4. Remove the engine splash shield. This requires a T30 Torx bit. There are 15 screws in total. **FX4 models need not remove entire skid plate**, only remove those screws required to remove the bumper cover.

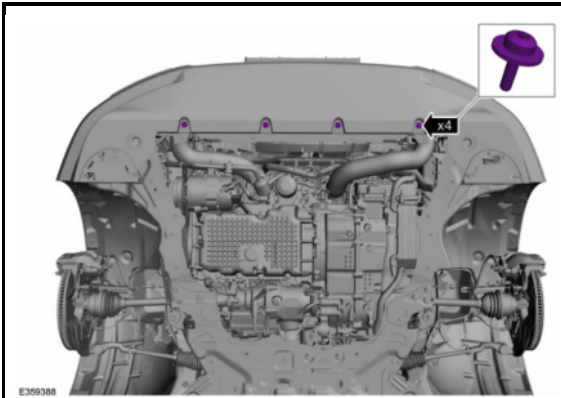

5. Remove the four screws securing the lower bumper valance. Also a T30 Torx.

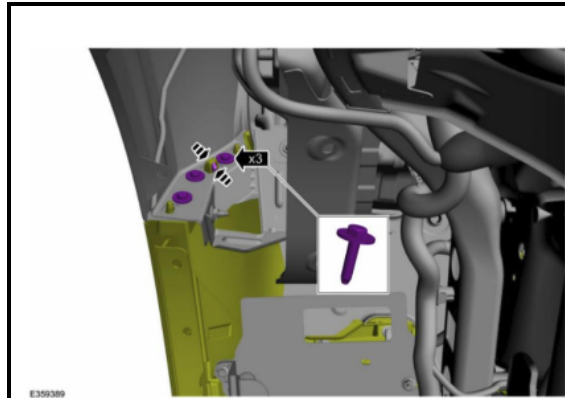

6. On both sides, remove the three bolts that secure the bumper cover to the fender. The bolts are 10mm. There is also a clip on each side that must be released as shown below.

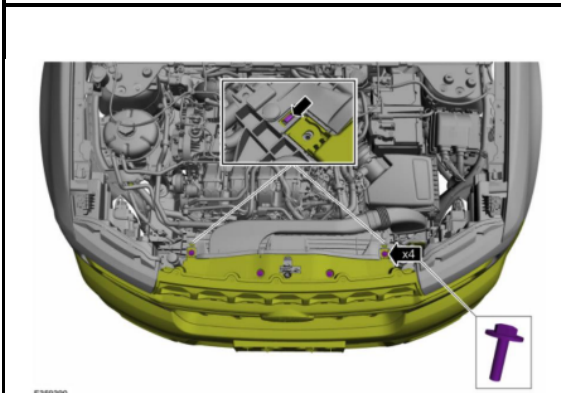

7. Remove the four screws that secure the upper grille as identified below.

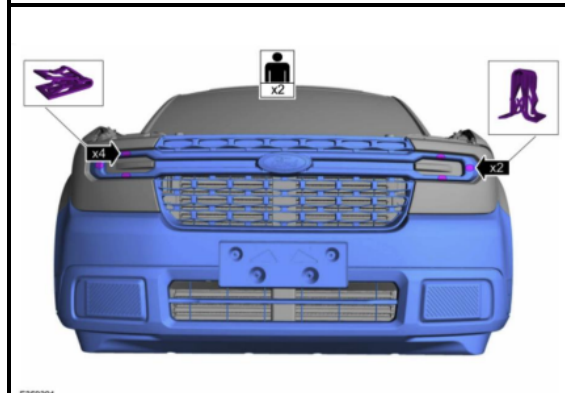

8. Release the clips that are behind the grille. These clips are built into the headlights, so be very carefully as not to damage the headlights.

9. The bumper is now ready to be removed from the vehicle. An additional person may be helpful to make sure that the bumper is not damaged as you carefully remove it from the vehicle. Prior to removing the bumper cover, it would be wise to place a moving blanket nearby or in front of the vehicle as to avoid any paint damage while the bumper cover is off the vehicle.

10. With the bumper cover and grille removed, remove the two bolts below (10mm), these will be reinstalled with the light mounts. You may also need to remove a few of the active grille shutters.



11. Using the supplied hardware, loosely assemble the light mount and attach it to the chassis as shown below, remember to reuse the two bolts previously removed. With the brackets mounted securely, you can now install your lights. Please note that space is tight where the lights will mount, so you may need to remove and reinstall the light bar to properly mount and aim your lights.



Once you are satisfied with the aim of your lights, you can fully tighten the light mount assembly. Make sure that your lights and all mounting points are secure. To reinstall the front bumper & grille, simply follow the removal steps in reverse.



Congratulations on installing your stealth grille light mount! 🎉

DISCLAIMER FOR JJC LLC PRODUCTS: Buyer assumes all risk and liability whatsoever for the installation and use of JJC LLC products. JJC LLC assumes no liability for injury, loss, incidental or consequential damages incurred as a result of the use or installation of these products. Professional installation is recommended.