

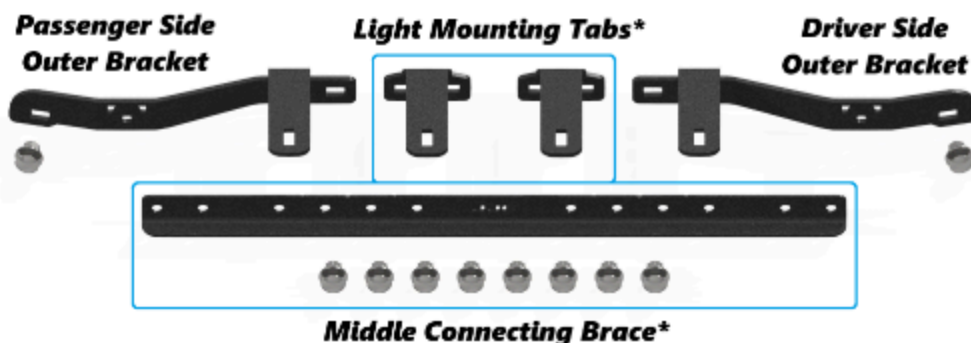

2022+ Ford Maverick Grille Light Brackets



***Additional Contents only included with complete light bar assembly**

| CONTENTS - Two Light Option | | TOOLS |
|--|---|---|
| QTY | DESCRIPTION | |
| 2 | Outer Grille Light Bracket (One Left & One Right) | 7mm, 10mm & 13mm sockets and/or wrenches T30 Torx Bit Plastic Clip Removal Tool |
| 2 | Carriage bolt w/ washers & nut | |
| Additional contents* - Four Light Option | | |
| 2 | Light Mounting Tabs | |
| 1 | Middle Connecting Brace | |
| 8 | Carriage bolt w/ washers & nut | |

Installation Instructions

Bumper Cover Removal

The factory manual suggests that you remove the front wheels prior to removing the front bumper cover; this is not entirely necessary but could allow for easier access for the rest of the bumper cover removal.

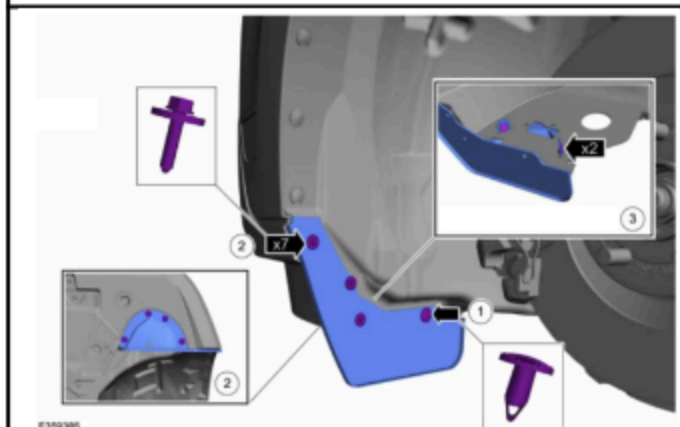

1. Remove the plastic air deflectors. This requires a 7mm socket for the screws and a small pry tool for the clips. To remove the clips, you must first raise the inner pin. With the inner pin raised or removed, you can then remove the outer pin (see 1 below). This step applies to both sides.

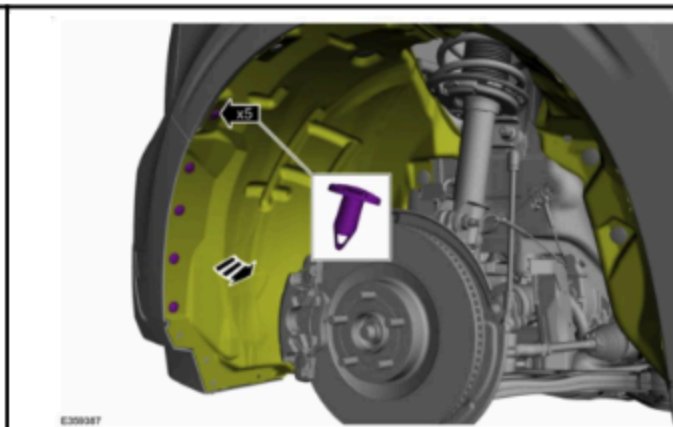

2. Remove the 5 push pins that secure the fender liner to the bumper cover and fender. Applies to both sides.

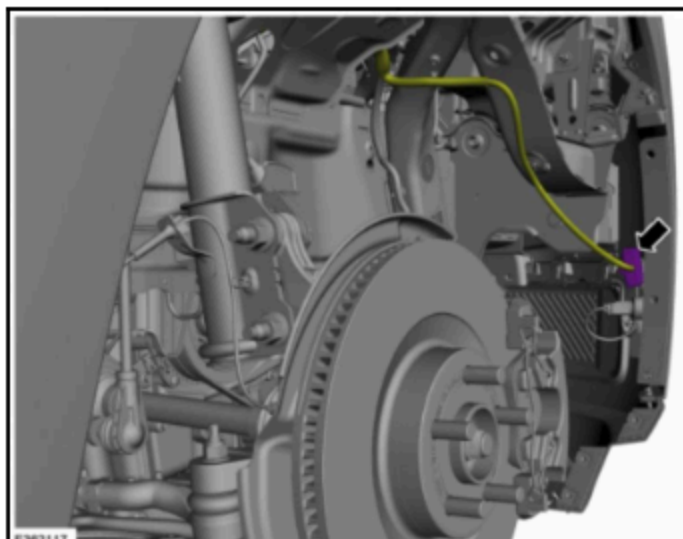

E302117

3. Disconnect the front bumper wiring harness. This is located on the passenger side and can be accessed from behind the fender liner

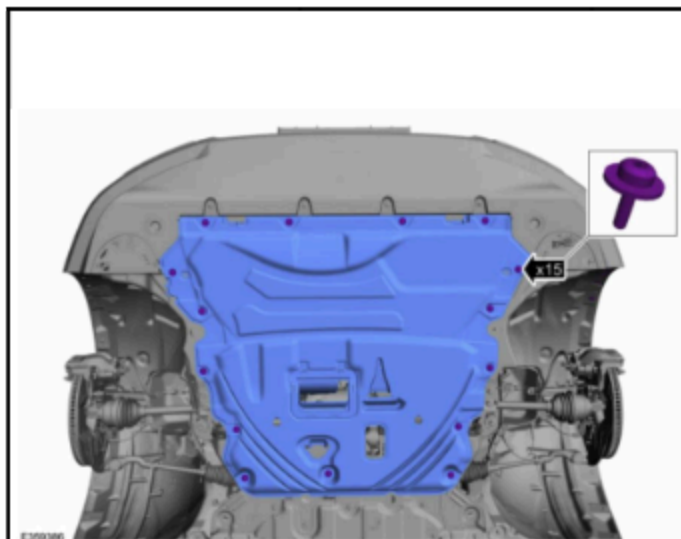

E309366

4. Remove the engine splash shield. This requires a T30 Torx bit. There are 15 screws in total. **FX4 models need not remove entire skid plate**, only remove those screws required to remove the bumper cover.

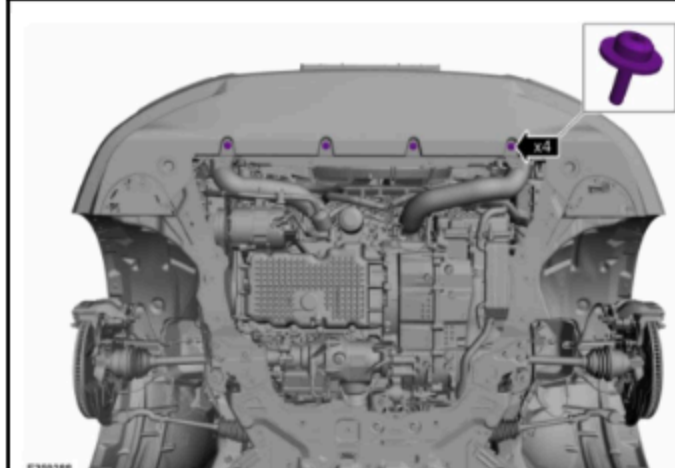

E309386

5. Remove the four screws securing the lower bumper valve. Also a T30 Torx.

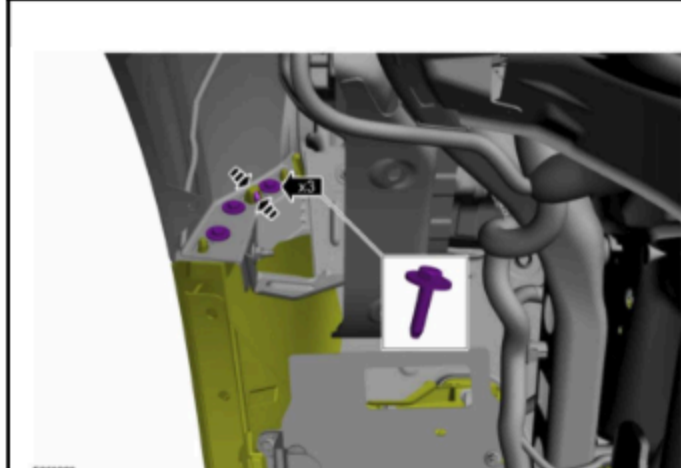

E309389

6. On both sides, remove the three bolts that secure the bumper cover to the fender. The bolts are 10mm. There is also a clip on each side that must be released as shown below.

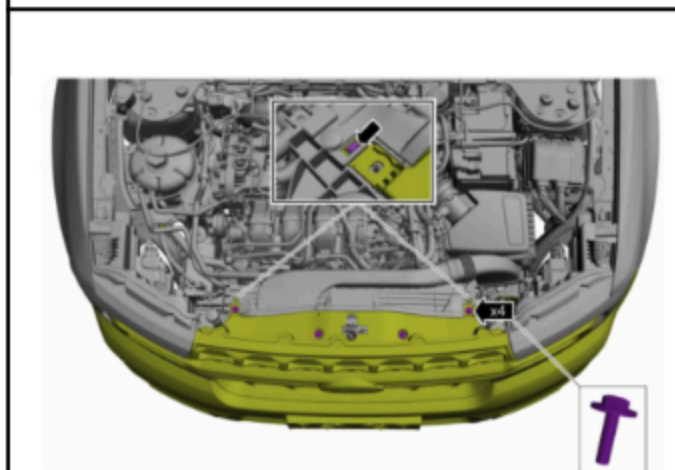

E309390

7. Remove the four screws that secure the upper grille as identified below.

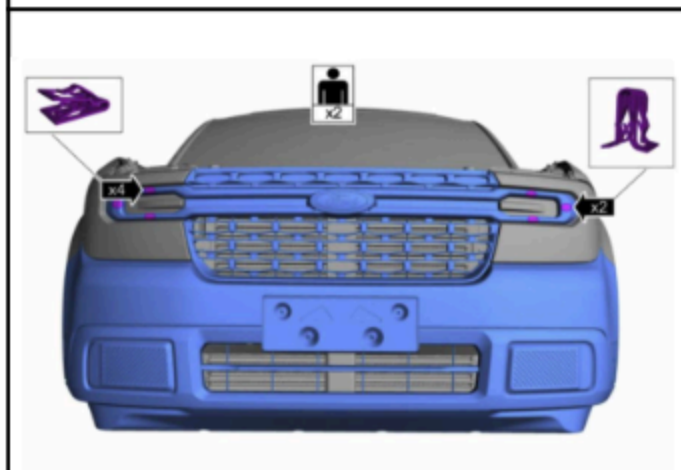

E309391

8. Release the clips that are behind the grille. These clips are built into the headlights, so be very carefully as not to damage the headlights.

9. The bumper is now ready to be removed from the vehicle. An additional person may be helpful to make sure that the bumper is not damaged as you carefully remove it from the vehicle. Prior to removing the bumper cover, it would be wise to place a moving blanket nearby or in front of the vehicle as to avoid any paint damage while the bumper cover is off the vehicle.

-With the bumper cover and grille removed, remove the two bolts below (10mm), these will be reinstalled with the grille light brackets.

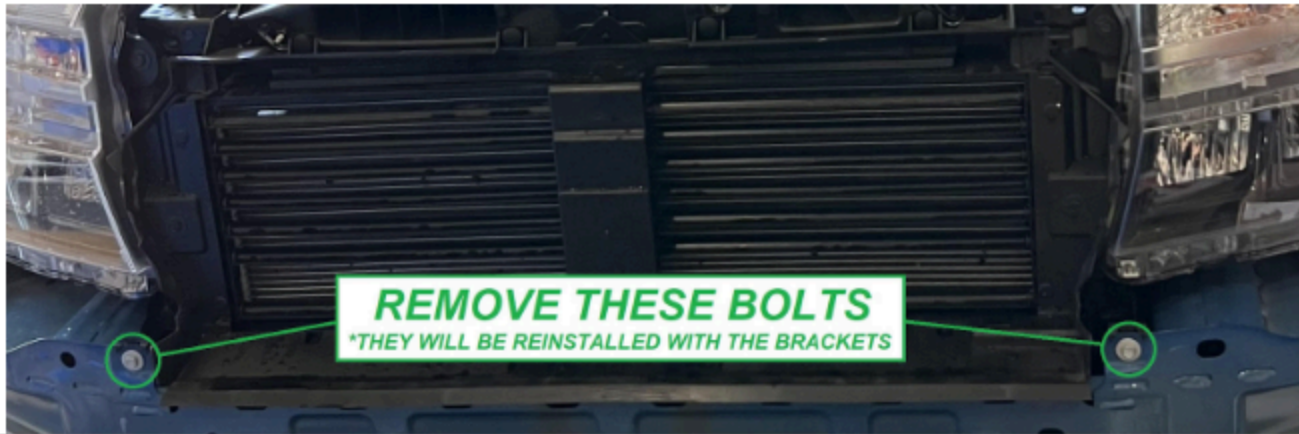

-Minor plastic trimming may be required in the following areas:

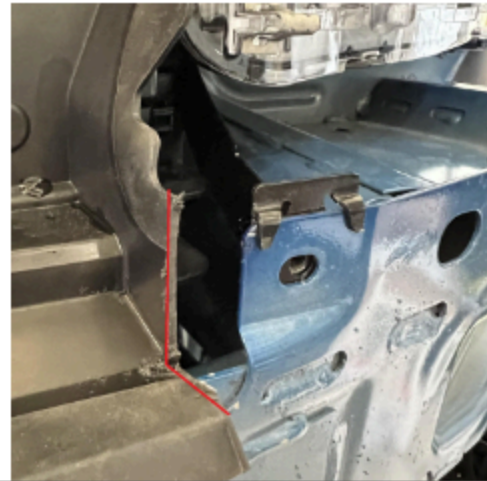

Light Bar Assembly

- If you are installing 2 lights, move on to Outer Bracket/Light Bar Installation
- If you are installing 4 lights, assemble the light bar as shown below using the included hardware
- the light mounting tabs on XLT models will be installed in the outer mounting locations
- the mounting tabs on XL & Lariat models be installed in the middle mounting locations



XLT



XL & LARIAT



Outer Bracket/Light Bar Installation

- outer brackets (or complete light bar) install using the included hardware and the two bolts previously removed
- passenger side prototype bracket install shown below for reference

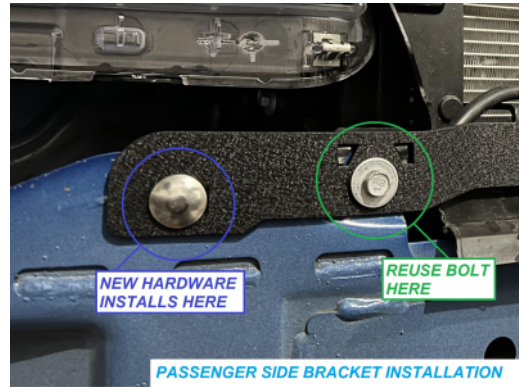

- Before reinstalling the bumper/grille, you may wish to run your wiring leads to the grille area at this time
- The light mounting tabs pass through the grille, follow the bumper removal steps in reverse to reinstall the bumper. Once the bumper/grille are reinstalled, you can install your lights onto the mounting tabs

TWO LIGHTS - OUTER BRACKETS ONLY



FOUR LIGHTS - COMPLETE LIGHT BAR

Congratulations on installing your grille lights! 🎉

DISCLAIMER FOR JJC LLC PRODUCTS: Buyer assumes all risk and liability whatsoever for the installation and use of JJC LLC products. JJC LLC assumes no liability for injury, loss, incidental or consequential damages incurred as a result of the use or installation of these products. Professional installation is recommended.