



2022+ Ford Maverick FX4 Fog Light Brackets & Bezels

CONTENTS		TOOLS
QTY	DESCRIPTION	7mm, 10mm & 12mm sockets and/or wrenches
2	Fog Light Brackets (One Left & One Right)	T30 Torx Bit
2	Fog Light Bezels (One Left & One Right)	Plastic Clip Removal Tool
1	Hole Template	

Installation Instructions

Bumper Cover Removal

The factory manual suggests that you remove the front wheels prior to removing the front bumper cover; this is not entirely necessary but could allow for easier access for the rest of the bumper cover removal.

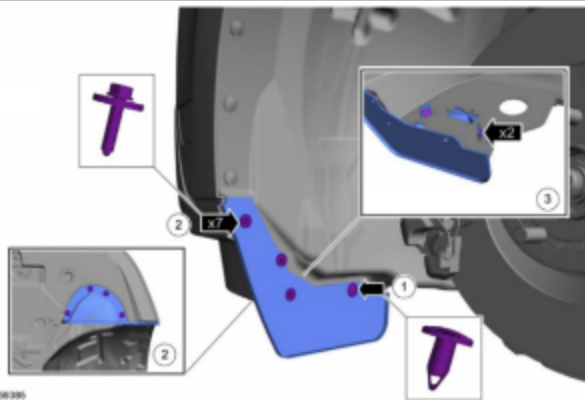

1. Remove the plastic air deflectors. This requires a 7mm socket for the screws and a small pry tool for the clips. To remove the clips, you must first raise the inner pin. With the inner pin raised or removed, you can then remove the outer pin (see 1 below). This step applies to both sides.

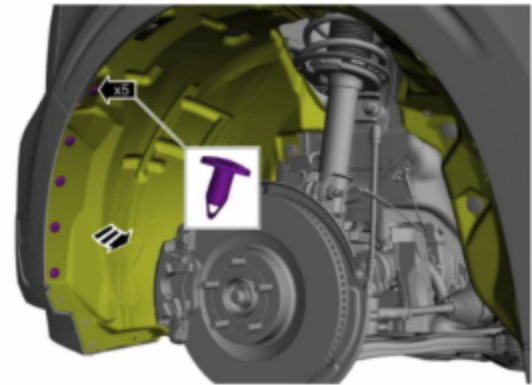

2. Remove the 5 push pins that secure the fender liner to the bumper cover and fender. Applies to both sides.

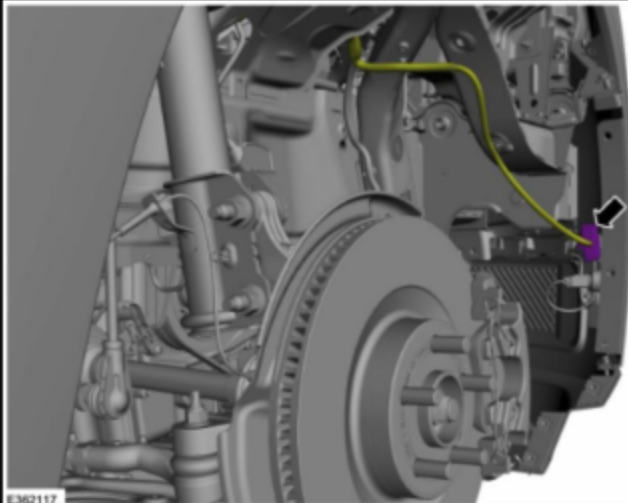

3. Disconnect the front bumper wiring harness. This is located on the passenger side and can be accessed from behind the fender liner

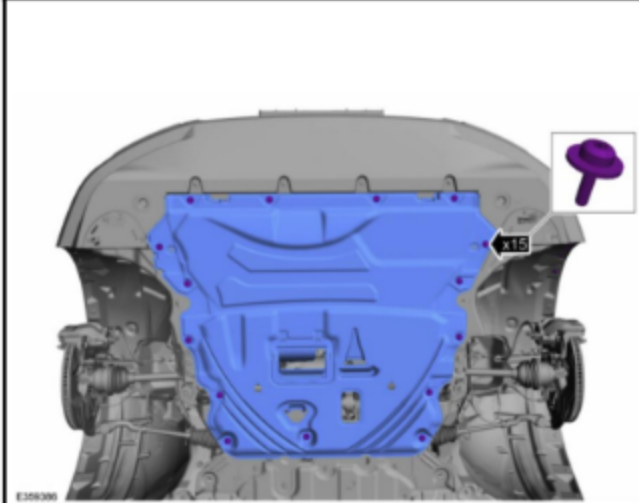

4. Remove the engine splash shield. This requires a T30 Torx bit. There are 15 screws in total. **FX4 models need not remove entire skid plate**, only remove those screws required to remove the bumper cover.

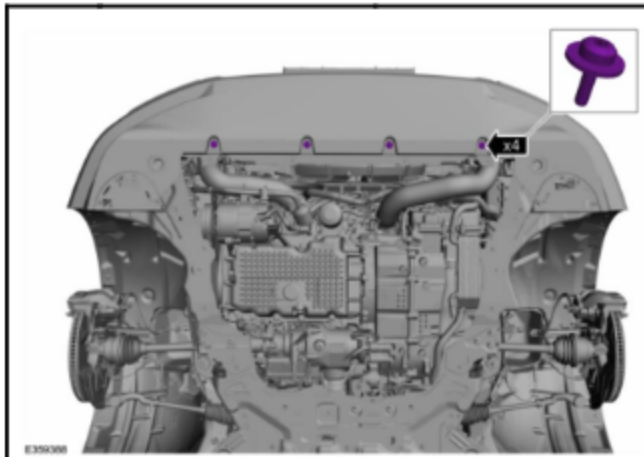

5. Remove the four screws securing the lower bumper valance. Also a T30 Torx.

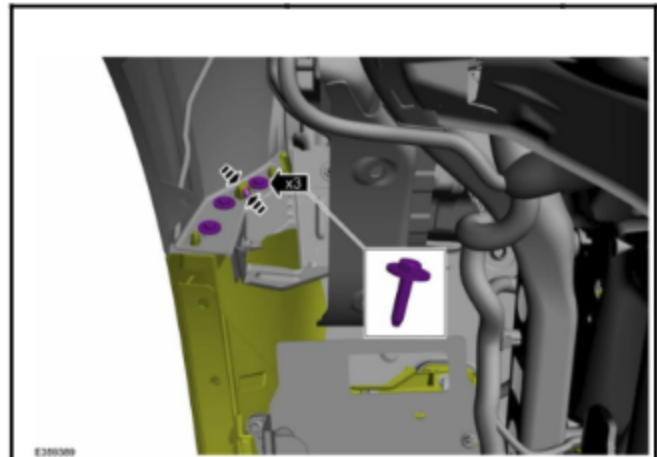

6. On both sides, remove the three bolts that secure the bumper cover to the fender. The bolts are 10mm. There is also a clip on each side that must be released as shown below.

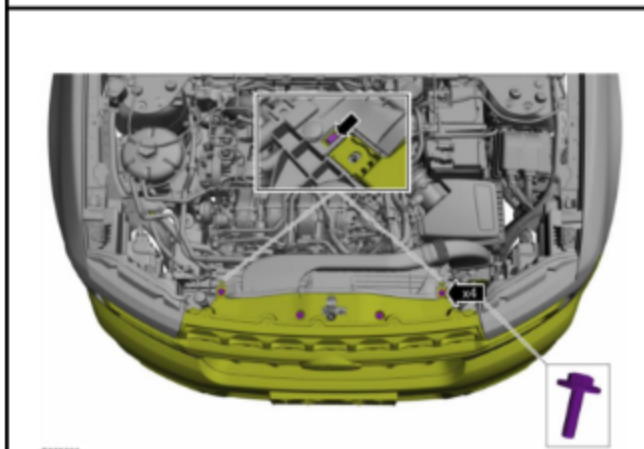

7. Remove the four screws that secure the upper grille as identified below.

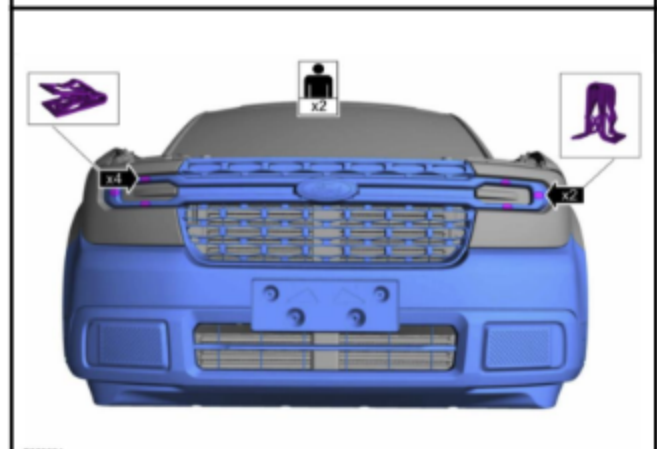

8. Release the clips that are behind the grille. These clips are built into the headlights, so be very carefully as not to damage the headlights.

9. The bumper is now ready to be removed from the vehicle. An additional person may be helpful to make sure that the bumper is not damaged as you carefully remove it from the vehicle. Prior to removing the bumper cover, it would be wise to place a moving blanket nearby or in front of the vehicle as to avoid any paint damage while the bumper cover is off the vehicle.

10. With the bumper cover removed, you can now install the fog light brackets. The fog light brackets will install in between the tow hooks and the chassis in the areas identified below.



Bracket Installation



To install the brackets, remove the front tow hook bolts (12mm), insert the bracket and reattach the tow hook as shown. With the brackets mounted securely, you can now install your lights. (Passenger side shown above for reference)

You may have noticed that the mounting brackets are slotted vertically, this is to accommodate both 2" and 3" lights.

- If you are installing 3" lights, start with the mounting brackets mounted all of the way up and adjust down as needed.
- If you are installing 2" lights, start with the brackets mounted all of the way down and adjust up as needed.

Bezel Installation

Using the included bezels as templates, the bezels can be temporarily placed on the bumper cover to mark the fog light openings that need to be cut. Once marked, you can carefully cut the openings. Remember, it is easy to remove more material as necessary but it is rather impossible to add material back if you cut too far; so start small with your cutting and increase your opening size only as needed. The entire opening does not need to be cut, only cut what is necessary for your particular installation.

IMPORTANT: DO NOT CUT OUTSIDE OF THE AREA OUTLINED IN RED BELOW.



A hole template is also provided to help mark the outer corners that need to be drilled in order to install the bezels. For these holes, $\text{\O}3/16''$ is all that is needed but $\text{\O}1/4''$ drill bit will also work. Do not exceed $\text{\O}1/4''$ holes.



Completed installation of driver side bezel shown below.



With the bezels installed, you may now continue with your fog light alignment. The bumper cover will need to be test fitted to the vehicle to aid in locating and aiming your lights. This may require several test fits in order to complete installation. It is best to start with the passenger side as it is fairly open behind the bumper on that side. The driver side has the ECU behind the bumper cover, so workspace is much tighter. Starting with the passenger side will give you a better idea of how to mount and aim your lights for the driver side, as the driver side will simply be mirrored from the passenger side. Once you are satisfied with the placement and aim of your lights, make sure to tighten all of the tow hook mounting points and reinstall the bumper cover. The bumper cover removal steps as previously outlined can be followed in reverse to properly reinstall the bumper cover.



Congratulations on adding fog lights to your Maverick FX4! 👍

DISCLAIMER FOR JJC LLC PRODUCTS: Buyer assumes all risk and liability whatsoever for the installation and use of JJC LLC products. JJC LLC assumes no liability for injury, loss, incidental or consequential damages incurred as a result of the use or installation of these products. Professional installation is recommended.