

Hunter

DDI

POWER & EFFICIENCY	20'	24'
INPUT POWER OPTIONS	AC 1PH 200-240V 50/60Hz AC 3PH 200-240V 50/60Hz AC 3PH 380-480V 50/60Hz	
RATED CURRENT (Amp)	6.5 A 3.5 A 3.0 A	6.5 A 3.5 A 3.0 A
MAXIMUM SPEED (RPM)	71 RPM	51 RPM
AFFECTED AREA	105 ft Dia 11,000 sqft	115 ft Dia 13,000 sqft

DIMENSIONS & WEIGHT

FAN DIAMETER	20 ft	24 ft
FAN WEIGHT	141 lbs (64 kg)	150 lbs (68 kg)

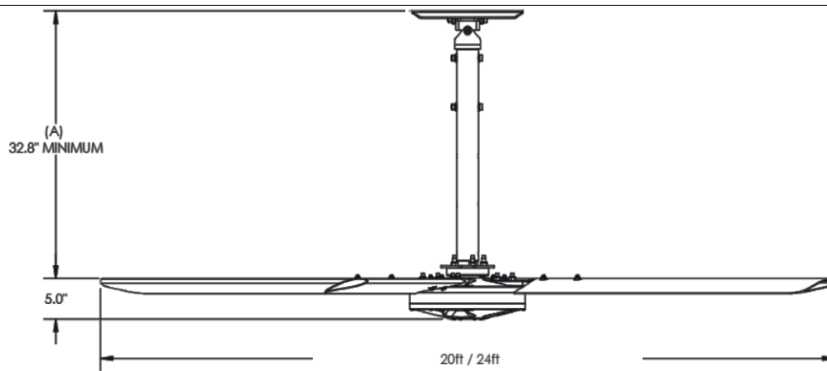

MOUNTING & SAFETY

MOUNTING OPTIONS	I-beam Glulam
DOWNROD (A)	Downrods available in 3 adjustable increments: 2.5-4 ft, 4.5-6ft, 6.5-10ft. Downrod length must be specified at time of order.
SAFETY FEATURES	Fan Retention System Airfoil Retention System Fire Relay

IN THE BOX

INCLUDED	Fan I-beam mount with pre-wired downrod Control panel Install manual Mounting hardware kit Communication Kit Guy wire kit
OPTIONAL	Additional cable lengths Glulam brackets Fire Relay

WARRANTY & CERTIFICATIONS

CERTIFICATIONS	ETL/Intertek-certified to ANSI/UL 507 and CSA C22.2 No. 113 in North America
WARRANTY ¹	Limited 5-Year Warranty

¹See complete warranty for details.

