

ProtoNode FPC-N64 GATEWAY for Interfacing Hunter Commercial TRAK Fans Quick Start

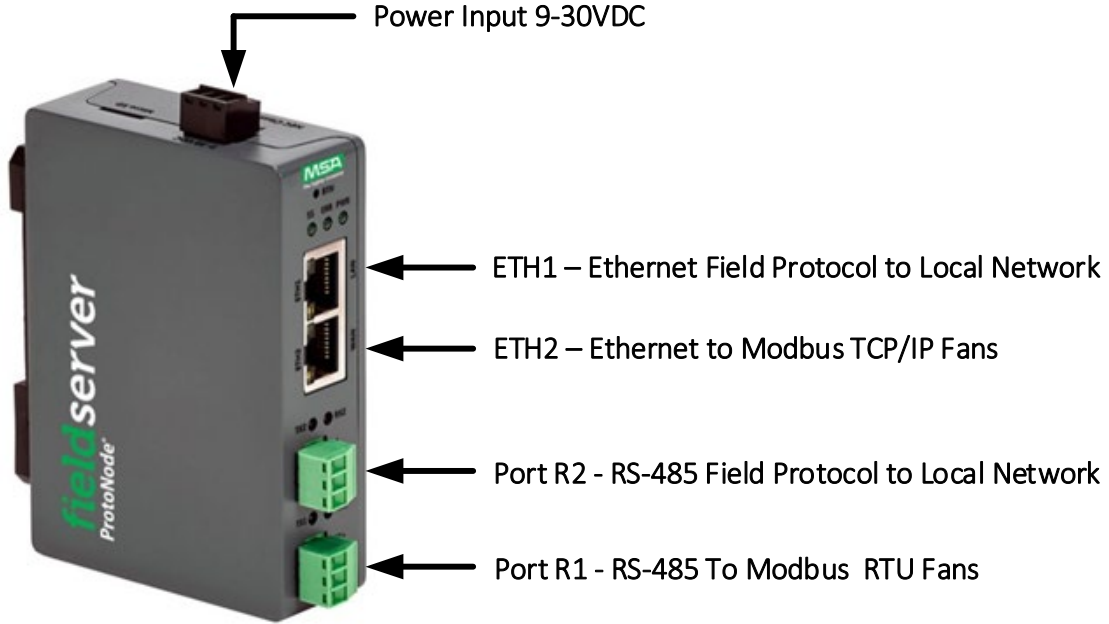

Modbus RTU Fans connection to ProtoNode Gateway

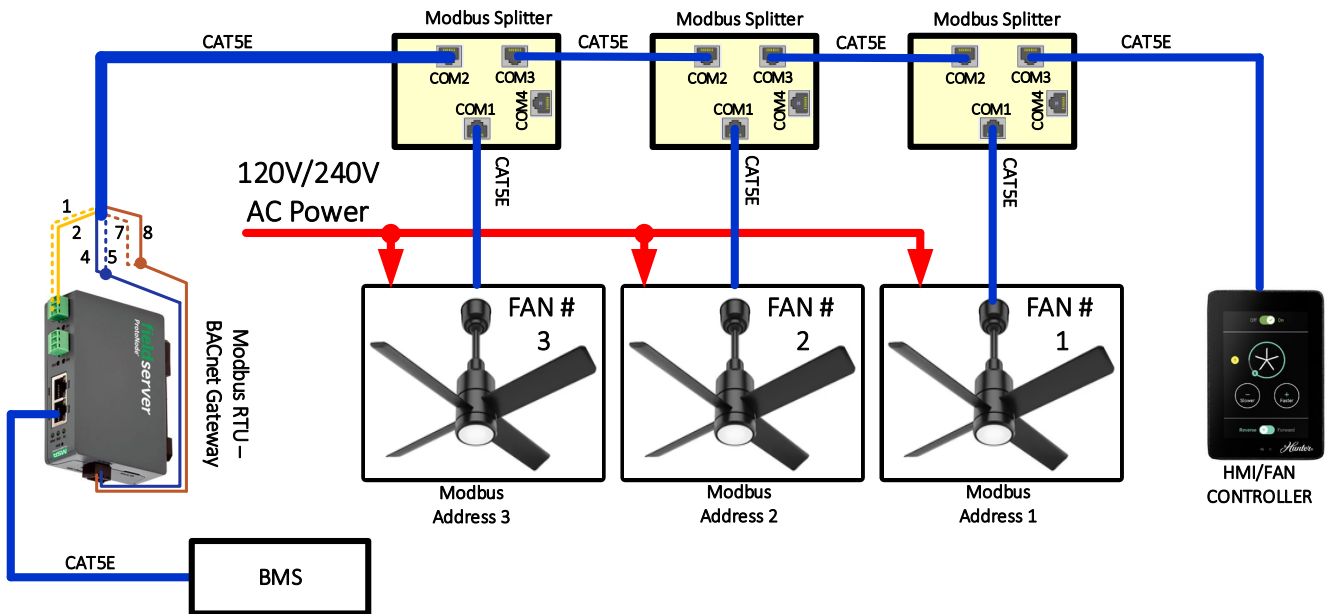

Figure 1 – Sample 3-Fans system connection.

- Whether the system is 1-Fan or Multi-Fan, each Modbus RTU fan interfaces with the ProtoNode Gateway via the Modbus Splitter's COM1. The Gateway is connected to COM2 (or COM3) of the Modbus Splitter, which includes both 24VDC power and RS485 signals from the fan. Figure 1 shows a 3-Fans system connection. Note: Only COM2 and COM3 of the Modbus Splitter have 24VDC output to supply power to the Gateway. COM4 has RS485 signals only. COM1 must be connected to the fan.

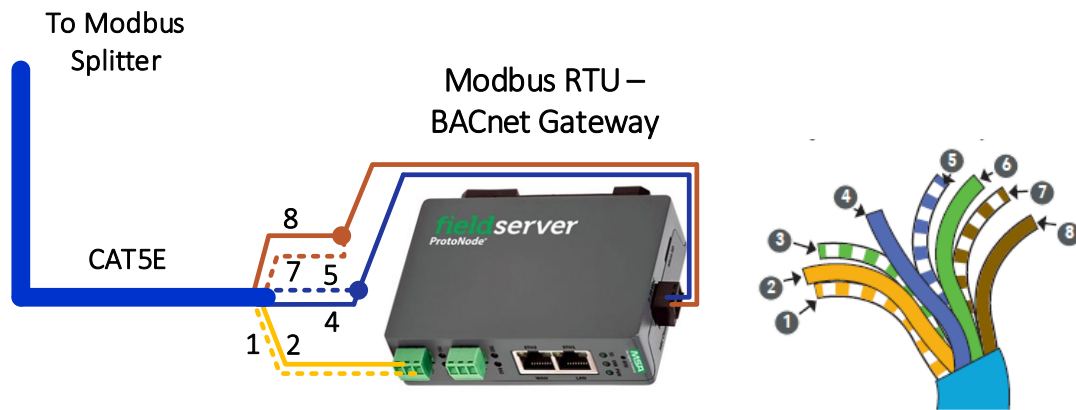

Figure 2 – CAT5E Ethernet cable pin out and Gateway connection

Figure 2 shows the connection of ethernet cable to the Gateway with the end of the cable insulation cutoff to show the pinouts of CAT5E.

1. Power up the Gateway via Power-over-Ethernet cable

Caution: Verify that the ethernet cable is disconnected from the Modbus Splitter and AC power to the fans are shut off.

Modbus RTU Fan Pins	CAT5 Pinout	FieldServer ProtoNode Pin Label	Pin Assignment
24VDC	Pin 4,5 (Blue-Solid, Blue-Stripe)	+ L	VDC+
GND	Pin7,8 (Brown-Stripe, Brown-Solid)	- N	VDC-

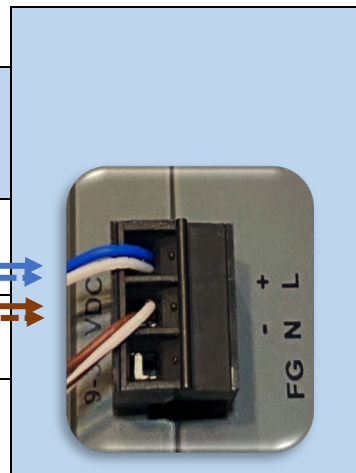

Figure 3 – 24VDC Connection to the Gateway

- 1.1 - Strip pin 4 (Blue-Solid) and pin 5 (Blue-Stripe) of the ethernet cable and connect to +L terminal of the Gateway for 24VDC power.
- 1.2 - Strip pin 7 (Brown-Stripe) and pin 8 (Brown-Solid) of the ethernet cable and connect to -N terminal of the Gateway for DC- Ground as shown in Figure 3.

2. Communication signals to the Gateway

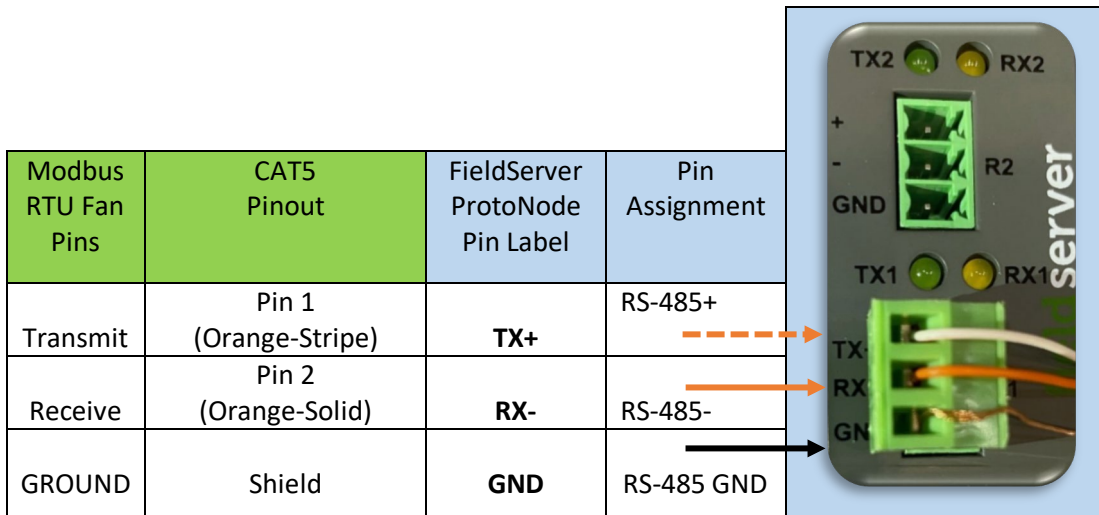

Figure 4 – RS-485 Serial Connection to the Gateway

- 2.1 - Strip pin 1 (Orange-Stripe) of the ethernet cable and connect to TX+ R1 terminal of the Gateway for RS-485+ signal.
- 2.2 - Strip pin 2 (Orange-Solid) of the ethernet cable and connect to RX- R1 terminal of the Gateway for RS-485- signal.
- 2.3 - Connect ethernet cable shield wire to GND -R1 terminal of the Gateway for RS-485 ground.

3. Verify Power and Communication

- 3.1 - Turn on AC power to the fans and connect the ethernet cable from the Gateway to the Modbus Splitter's COM2. Verify the gateway power good indication LED is green as shown in Figure 6.

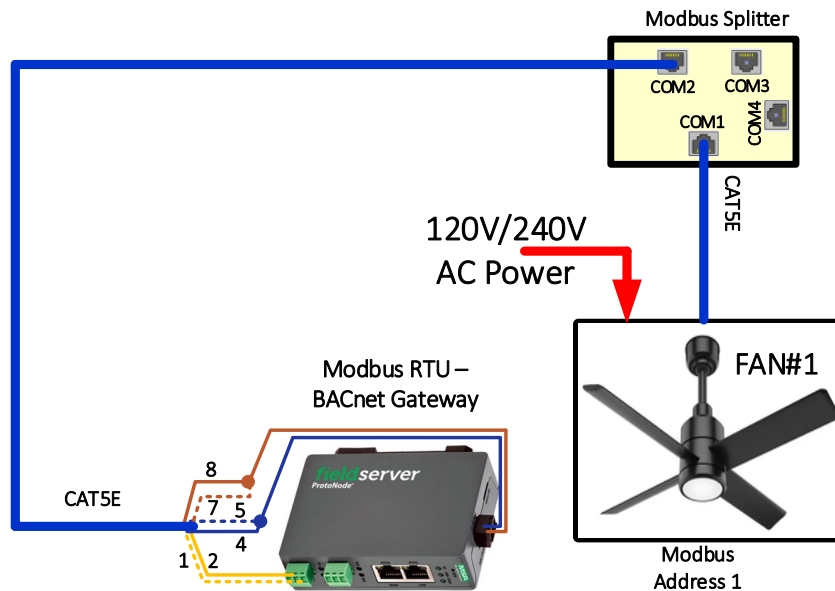

Figure 5 – Gateway connected to Modbus Splitter COM2 for Power and Communication



Figure 6 – Gateway power good indication LED

4. Connect the local PC to the Gateway

4.1 Connect CAT5E cable from Gateway ETH1 (LAN) to local PC.

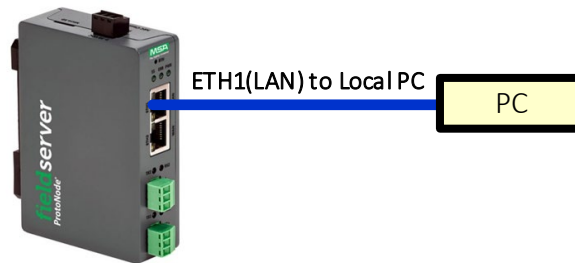
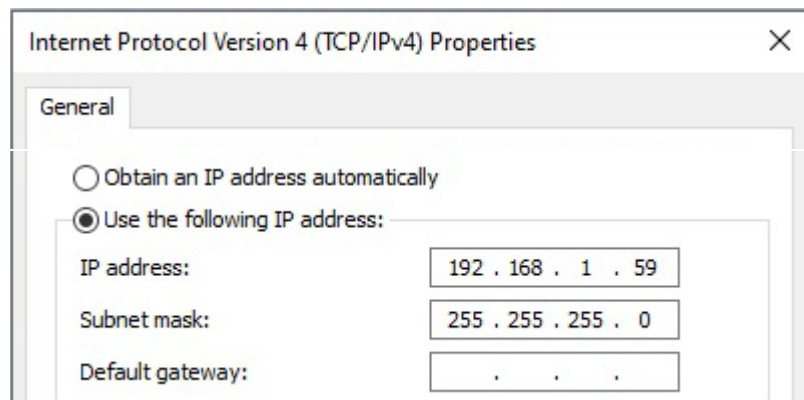
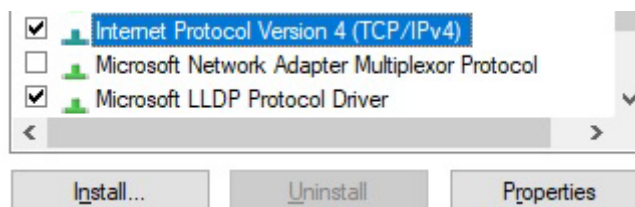

Figure 7 – Gateway ETH1 connected to local PC

4.2 Change the Subnet of the connected PC. The default IP Address for the ProtoNode is **192.168.1.24**, Subnet Mask is **255.255.255.0**. If the PC and ProtoNode are on different IP networks, assign a static IP Address to the PC on the 192.168.1.xxx network. For example, in Windows, go to “Control Panel” → “Network and Sharing Center” → “Change Adapter Settings” → “Local Area Connection” → “Properties” → “Internet Protocol Version 4 (TCP/IPv4)”, select a static IP address for the local PC **192.168.1.59**, Subnet mask **255.255.255.0**



5. Login to the Gateway

Open a web browser and connect to the FieldServer's default IP Address: 192.168.1.24

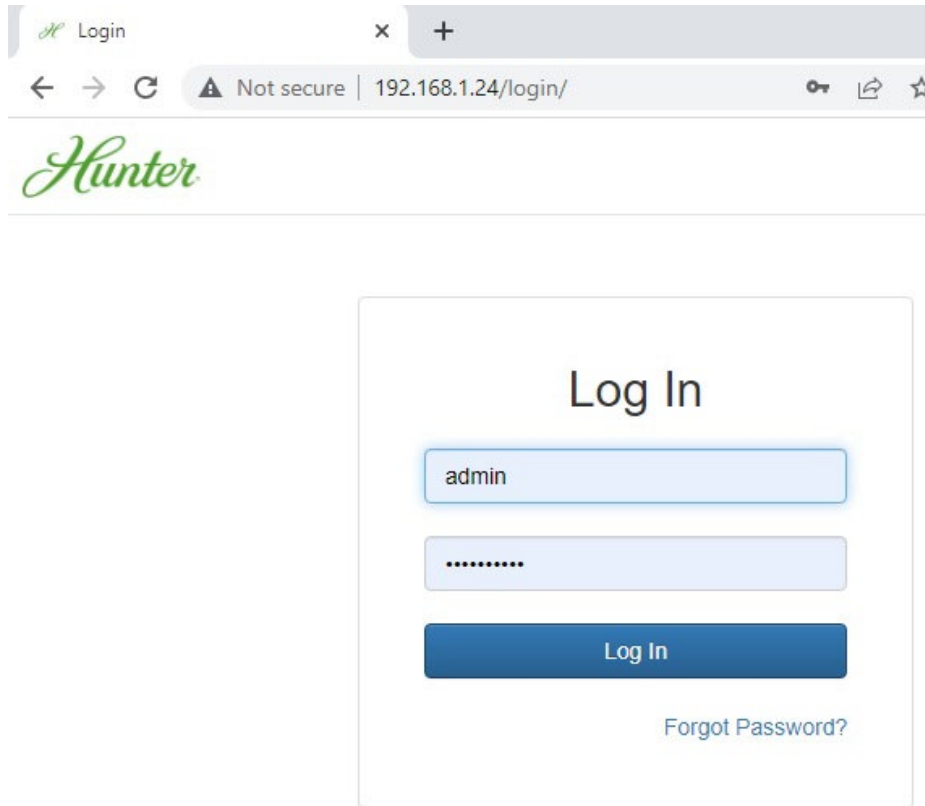

Username: admin

Password: use Default Password listed on the side of the Gateway's enclosure.



6. Setting Active Profiles for Fans

6.1 Within Hunter's main page, select Setting → Configuration → Profiles Configuration.

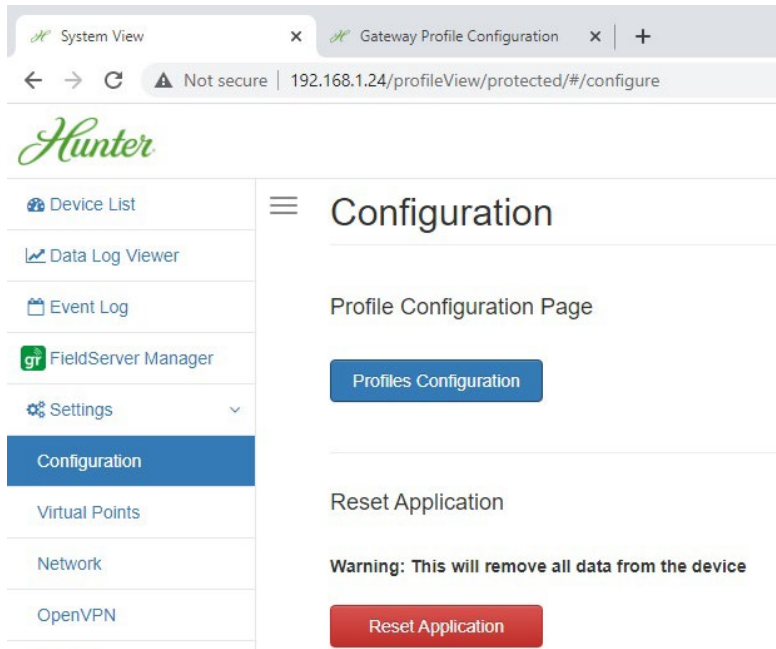

6.2 Select default parameters with BACnetIP protocol selection, unless BACnet MSTP is used.

Configuration Parameters		
Parameter Name	Parameter Description	Value
protocol_select	Protocol Selector Set to 1 for BACnet IP Set to 2 for BACnet MSTP Set to 3 for Metasys N2	<input type="text" value="1"/> <input type="button" value="Submit"/>
output_adapter	Protocol Output Adapter This sets the output adapter for the protocol translation. Use N1 for LAN port 1 Use N2 for LAN port 2 (N1/N2)	<input type="text" value="N1"/> <input type="button" value="Submit"/>
mod_baud_rate	Modbus RTU Baud Rate This sets the Modbus RTU baud rate. (9600/19200/38400/57600)	<input type="text" value="38400"/> <input type="button" value="Submit"/>
mod_parity	Modbus RTU Parity This sets the Modbus RTU parity. (None/Even/Odd)	<input type="text" value="None"/> <input type="button" value="Submit"/>
mod_data_bits	Modbus RTU Data Bits This sets the Modbus RTU data bits. (7 or 8)	<input type="text" value="8"/> <input type="button" value="Submit"/>
mod_stop_bits	Modbus RTU Stop Bits This sets the Modbus RTU stop bits. (1 or 2)	<input type="text" value="1"/> <input type="button" value="Submit"/>

HELP (?)
Clear Profiles and Restart
System Restart
Diagnostics & Debugging
fieldserver

6.3 Add Active Profiles. Each Modbus RTU fan is designated with Modbus address (NODE ID) starting with 1. For example: 1 fan system connection, add 1 profile with Fan 1 NODE ID =1.

And for 3 fan system connection, add 3 profiles with Fan 1 NODE ID = 1, Fand 2 NODE ID = 2, Fan 3 NODE ID = 3.

Active profiles

Nr	Node ID	Current profile	Parameters	
1	1	MOD_RTU_to_BAC_IP_TRAK		Remove
2	2	MOD_RTU_to_BAC_IP_TRAK		Remove
3	3	MOD_RTU_to_BAC_IP_TRAK		Remove

Add

6.4 Select System Restart after profiles for each fan is added.

node_offset The device instance will be sum of the Modbus device 50000 Submit

Configuration update complete. Please restart the system to load the new Configuration.
(0 - 4194303)

Active profiles

Nr	Node ID	Current profile	Parameters	
1	1	MOD_RTU_to_BAC_IP_TRAK		Remove
2	2	MOD_RTU_to_BAC_IP_TRAK		Remove
3	3	MOD_RTU_to_BAC_IP_TRAK		Remove

Add

HELP (?) Clear Profiles and Restart Show config errors System Restart Diagnostics & Debugging **ieldserver**

192.168.1.24 says

System about to restart.

Press OK to continue

OK Cancel

6.5 Test connected fans by select fan profiles created in the Device List. Hunter's 192.168.1.24 main page

The screenshot shows the Hunter System View page. The browser address bar displays "192.168.1.24/profileView/protected/#/module". The page features a navigation menu on the left with options: Device List, Data Log Viewer, Event Log, FieldServer Manager, Settings, and About. The main content area is titled "System View" and displays a table of fan profiles under the heading "TRAK".

Name	Location	Description	Fan Fault Status	Fan Speed Command	Fan Output Speed Monitor
MOD_RTU_to_BAC_IP_TRAK_1_			<input type="checkbox"/>	0	0

6.6 Fan Operation Test

Start/Stop Fan Operation

- To start fan operation, select "Fan Updraft Dir CMD" or "Fan Downdraft Dir CMD" to command direction of the airflow and "SAVE".

This screenshot shows three fan operation control rows. Each row includes a graph icon, a bell icon, a label, a toggle switch, and an action button.

- Row 1: "Stop Fan CMD" with a grey toggle switch and an "Edit" button.
- Row 2: "Fan Updraft Dir CMD" with a green toggle switch, a "Save" button, and a "Cancel" button.
- Row 3: "Fan Downdraft Dir CMD" with a grey toggle switch and an "Edit" button.

- Select speed 1-10 in scaling percentage. Speed 1 = 1000, Speed 2=2000, Speed 3=3000, Speed 4=4000, Speed 5=5000, Speed 6=6000, Speed 7 = 7000, Speed 8=8000, Speed 9=9000, Speed 10=10000.

This screenshot shows three fan operation control rows. Each row includes a graph icon, a bell icon, a label, and a control element.

- Row 1: "Fan Updraft Direction Status" with a green toggle switch.
- Row 2: "Fan Fault Status" with a grey toggle switch.
- Row 3: "Fan Speed Command" with a text input field containing "5000", a "Save" button, and a "Cancel" button.

c. Stop Fan by select "Stop Fan CMD" command, and "Save"

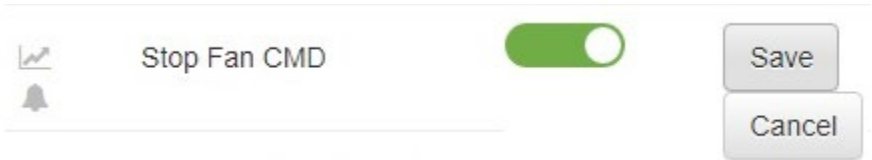

d. To turn on LED, select "LED On CMD" command and "Save"



e. Select brightness level 1-10 in scaling percentage. Level 1 = 1000, Level 2=2000, Level 3 3=3000, Level 4=4000, Level 5=5000, Level 6=6000, Level 7 = 7000, Level 8=8000, Level 9=9000, Level 10=10000.



f. To turn off LED, select "



6.7 TRAK FAN MODBUS RTU to BACnet REFERENCE

Point Name	BACnet Object Type	BACnet Object ID	N2 Data Type	N2 Address	Modbus Register
InvXXX Com Status Ok	BI	0	DI	1	10001
InvXXX Fan Controller Reset	BV	1	DO	1	40002.0
InvXXX Stop/Run Status	BI	2	DI	2	40009.0
InvXXX Fan Downdraft Direction Status	BI	3	DI	3	40009.1
InvXXX Fan Updraft Direction Status	BI	4	DI	4	40009.2
InvXXX Fan Fault Status	BI	5	DI	5	40009.15
InvXXX Fan Speed Command	AV	6	AO	6	40014
InvXXX Fan Output Speed Monitor	AI	7	AI	7	40201
InvXXX LED Off	BI	8	DI	8	40309.0
InvXXX LED On	BI	9	DI	9	40309.1
InvXXX LED Brightness Command	AV	10	AO	10	40314
InvXXX Fault History 1	AI	11	AI	11	40501
InvXXX Fault History 2	AI	12	AI	12	40502
InvXXX Fault History 3	AI	13	AI	13	40503
InvXXX Fault History 4	AI	14	AI	14	40504
InvXXX Fault History 5	AI	15	AI	15	40505
InvXXX Fault History 6	AI	16	AI	16	40506
InvXXX Fault History 7	AI	17	AI	17	40507
InvXXX Fault History 8	AI	18	AI	18	40508
InvXXX Stop Fan CMD	BV	19	DO	19	40009.0
InvXXX Fan Updraft Dir CMD	BV	20	DO	20	40009.1
InvXXX Fan Downdraft Dir CMD	BV	21	DO	21	40009.2
InvXXX LED Off CMD	BV	22	DO	22	40309.0
InvXXX LED On CMD	BV	23	DO	23	40309.1

*Note: Fan Output Speed Monitor Modbus Register (40201) is currently disabled. Set speed can only be read from Fan Speed Command Modbus Register (40014).