

GCH-300

300cc Gas Cylinder Heater

Overview

Natural gas sampling standards (GPA 2166 and API 14.1) recommend that before using the fill and empty method to collect a sample, the cylinder must be preheated to a temperature above the hydrocarbon dew point of the flowing gas stream. The GCH-300 provides a simple, efficient solution to cylinder preheating. It consists of a heater enclosure and a controller. The sample cylinder is preheated inside your vehicle on the way to, or at, the sample location. Heating takes about 10 minutes. To use the GCH-300 just insert a clean empty cylinder into the heater enclosure and connect the controller cable to the heater. Power for the heater is taken from a vehicle 12 volt power point or cigarette lighter plug. While heating, the sample cylinder's temperature can be monitored using the controller's display. When fully heated, the controller will keep the cylinder at the set temperature (140°F) until you are ready to disconnect the controller from the heater and take the sample. The hot cylinder stays in the heater enclosure until the sampling process is finished to provide a safe method to handle the heated cylinder while taking the sample without the need for gloves.



Features

- Designed to preheat a standard 2" OD 300cc gas sample cylinder
- Low power (50 watts @ 12V DC) plugs directly into a cigarette lighter
- Works with either stainless steel or aluminum cylinders
- Quickly preheats cylinder to 140°F, *Cold to Hot in about 10 minutes*
- Microprocessor based temperature controller with digital temperature display
- Rugged plastic case provides a safe compact environment for heating the cylinder plus a safe and durable method for handling the heated cylinder
- Enclosure insulates heated cylinder to allow for additional hot sampling time
- Dual heaters help insure uniform heating of the sample cylinder
- Increased safety provided by thermal fuses and transient protection diodes

Operation

The following operating procedures will guide you through connecting the controller to the heater and preheating a sample cylinder.

For best heating efficiency, use clean sample cylinders and avoid stickers, labels or any material on the sides of the cylinder. It is important that the sample cylinder make good thermal contact with the cylinder clip. Dirt or stickers on the sample cylinder will interfere with heat flow from the heaters to the sample cylinder and could affect performance.

During the heating process the controller continuously monitors the two temperature sensors. The average of the two sensor's readings is used to control the heaters. A large difference between the two sensor readings is an indication of a possible heater failure. For example a bad heater would be detected as a warm reading on one sensor and a cooler reading on the sensor next to the bad heater. When this error is detected, an error or "E" code will show on the controller display in place of the temperature reading. If the heater plug is disconnected from the heater while power is still on, the controller display will change to a scrolling "*" character indication that the controller can no longer read the temperature sensors. When the plug is reconnected, the sensors will be detected and the display will return to displaying the cylinder temperature.

WARNING

- Only heat clean dry sample cylinders.
- Do not apply power to the controller in hazardous locations.
- Do not connect the controller to the heater in hazardous locations.
- Do not place the heater on surfaces that may be damaged by heat.

CAUTION

The sample cylinder and metal surfaces within the heater enclosure may be hot.

Handle the cylinder by the end valves when removing the heated cylinder from the enclosure.

Operating Procedure

- ▶ Open the heater enclosure and insert a clean dry 300cc sample cylinder into the cylinder clip.
- ▶ Close the heater enclosure and secure the latches.
- ▶ Locate the heater socket on the GCH heater and unscrew the protection cap.
- ▶ Connect the heater plug on the control cable to the heater socket on the GCH heater. Twist the locking ring clockwise to lock it into place.
- ▶ Plug in the power cable into a standard auto cigarette lighter or 12 volt power point.
- ▶ Turn on the power switch.
- ▶ The LED on the power switch will come on and the controller display will show the approximate cylinder temperature while heating the cylinder to the set temperature (140°F for the GCH-140 controller).
- ▶ When the cylinder has reached the desired temperature, turn off the power and disconnect the cable from the heater. Replace the connector protection cap.
- ▶ With the heater in the enclosure, begin the sample collection process.
- ▶ After the sample is collected, remove the cylinder from the enclosure. There is no longer any need to heat the cylinder until the sample is ready to be analyzed at a gas lab.
- ▶ Repeat this process to preheat the next cylinder.

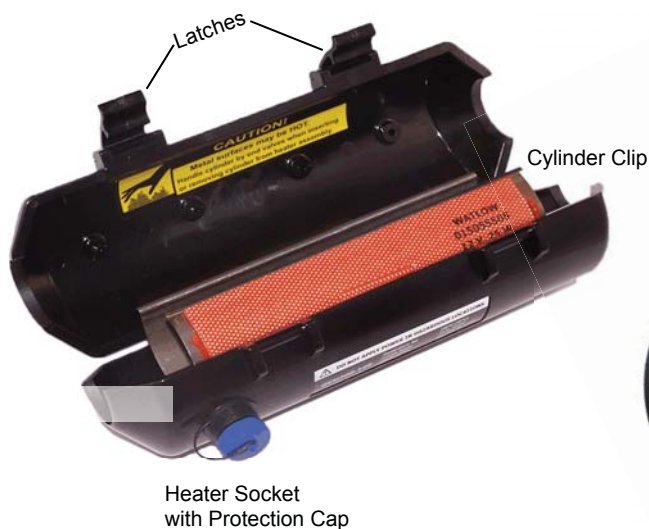

Note: If there is a temperature difference between the cylinder and the heater assembly, it may take several minutes before the controller reads the correct cylinder temperature when a cylinder is first inserted into the heater.

Maintenance

Keep the cylinder clip inside the heater clean and dry for maximum efficiency. Use a damp cloth to wipe off debris from the clip surface and both the inside and outside of the heater enclosure. Avoid moisture on the connectors. Excessive moisture may interfere with the controllers ability to read the temperature sensors. To keep the connector clean and dry, use an electronics contact cleaner that leaves no residue and that does not harm plastics.

Specifications

Heaters 50 Watts @ 12V
Cylinder Size 300cc x 2.00" O.D.
Over-temperature Protection Thermal Fuses (2)
Temp Sensor Accuracy $\pm 2.0^{\circ}\text{C}$
Weight 1 Lb.

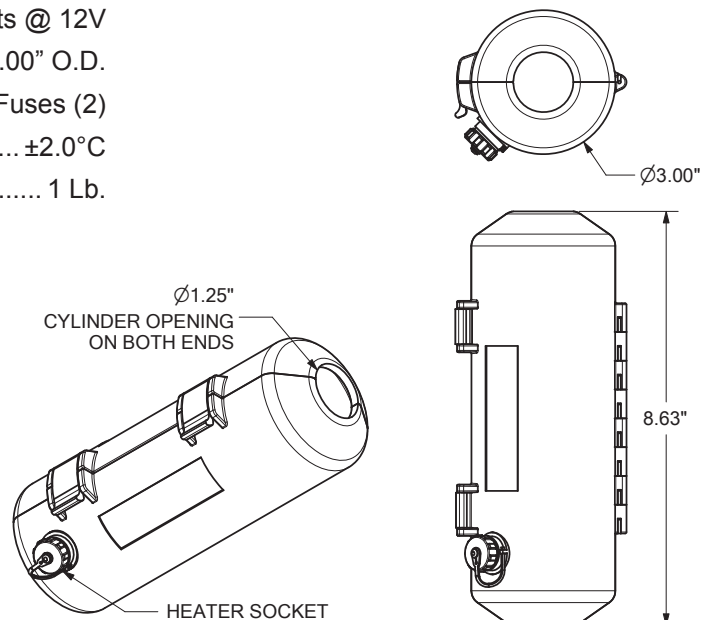

Limited Warranty

2KC Solutions, LLC warrants this unit against defects in materials and workmanship for a period of one year from the date of shipment. 2KC Solutions, LLC will, at its option, repair or replace equipment that proves to be defective during the warranty period. This warranty includes parts and labor.

A Return Materials Authorization (RMA) number must be obtained from the factory and clearly marked on the outside of the package before equipment will be accepted for warranty work.

2KC Solutions, LLC believes that the information in this manual is accurate. In the event that a typographical or technical error exist, 2KC Solutions, LLC reserves the right to make changes without prior notice to holders of this edition. The reader should consult 2KC Solutions, LLC if any errors are suspected. In no event should 2KC Solutions, LLC be liable for any damages arising out of or related to this document or the information contained in it.

EXCEPT AS SPECIFIED HEREIN, 2KC SOLUTIONS, LLC MAKES NO WARRANTIES OR MERCHANTABILITY OR FITNESS FOR A PARTICULAR PURPOSE. CUSTOMER'S RIGHT TO RECOVER DAMAGES CAUSED BY FAULT OR NEGLIGENCE ON THE PART OF 2KC SOLUTIONS, LLC SHALL BE LIMITED TO THE AMOUNT THERETOFORE PAID BY THE CUSTOMER. 2KC SOLUTIONS, LLC WILL NOT BE LIABLE FOR DAMAGES RESULTING FROM LOSS OF DATA, PROFITS, USE OF PRODUCTS, OR INCIDENTAL OR CONSEQUENTIAL DAMAGES, EVEN IF ADVISED OF THE POSSIBILITIES THEREOF. This limitation of the liability of 2KC Solutions, LLC will apply regardless of the form of action, whether in contract or tort, including negligence. Any action against 2KC Solutions, LLC must be brought within one year after the cause of action accrues. The warranty provided herein does not cover damages, defects, malfunctions, or service failures caused by owners failure to follow 2KC Solutions installation, operation, or maintenance instructions; owners modification of the product; owner's abuse, misuse, or negligent acts; and power failure or surges, fire, flood, accident, actions of third parties, or other events outside reasonable control.

Service

The GCH-300 has no field serviceable components. For service please contact your distributor listed below for a Return Materials Authorization number (RMA).

Microflex, LLC
2202 Red Bird Lane
Brookshire, Texas 77423

Phone: 281-855-9639
Fax: 832-422-4391
www.microflx.com

Solutions
www.2KCsolutions.com