

RS-485 CONVERTER

101-0009

RS-232 to 2-Wire RS-485 Converter

Installation Operation & Specifications Manual

- Auto transmit control eliminates RTS requirement
- Power Up/Down glitch-free permits live insertion or removal
- Powered from RS-232 port
- Common mode range permits +/-7V ground difference
- Not bus terminated - increases flexibility

General Description

The 101-0009 RS-232 to RS-485 Converter provides a simple, low cost interface between a PC or laptop with an RS-232 serial port, and 2-wire RS-485 devices. Several features of this converter make it simple to use while providing maximum compatibility. RS-232 control lines are looped back. Power for the converter is taken from the serial port lines - no external power supply is needed. In some cases, only transmit, receive, and ground are required. Power is also taken from DTR (data terminal ready) if provided. Switching between receive and transmit is automatically controlled. RTS (request to send) is not used to control transmit.

A rugged design makes 101-0009 an ideal choice for field engineers and technicians who service RS-485 2-wire equipment in an industrial environment. Because the 101-0009 RS-485 converter is used on devices without a ground terminal, voltage suppression is used to clamp the common mode voltage to +/- 7 volts to help prevent destruction of the converter.

For an RS-485 converter with a USB interface Microflex offers the 101-0010.



Software Setup

Make sure your software is set to use the same serial COM port that the RS-485 is configured to. There are no hardware settings required by the RS-485 Converter. Power is provided by the RS-232 serial port. All other settings, such as BAUD rate, are taken care of by your software. The converter automatically switches between transmit and receive so RTS is not required.

Getting Power from the RS-232 Port

Power for the converter is taken from the RS-232 control lines. There are three possible power sources, RTS, DTR, and TX. RTS and DTR provide power when they are at a positive potential, or active, while TX can provide power in either polarity. The amount of power that the converter needs depends on the RS-485 termination resistors and the number of devices on the bus. Additionally, higher BAUD rates may require additional power. If your application requires increased power, you may need to provide a high or active DTR while the converter is in use. Additional power can be added by driving both RTS and DTR active while the converter is in use.

Connecting to the RS-485 Device

Connect the two mini-clips to the RS-485 bus. Following the RS-485 standards, the black clip is the A connection and the red clip is the B connection.

- BLACK = A RS-485 Connection
- RED = B RS-485 Connection

Converter Grounding

The 101-0009 converter does not provide an RS-485 ground terminal. Unless the other device's interface is isolated, there is a risk of a ground loop current that could result in equipment damage. The converter should only be used where the common mode voltage (ground potential difference between the two interfaces) is within the standard RS-485 common mode voltage of +/- 7 volts.

Safety Considerations

FC Conformity in accordance with Part 2, and Part 15, Subparts A and B of the Federal Communications Rules and Regulations, and ICES-003 of the Industry Canada standards.



This device complies with part 15 of the FCC rules. Operation is subject to the following two conditions: (1) This device may not cause harmful interference, and (2) this device must accept any interference received, including interference that may cause undesired operation. Changes or modifications not expressly approved by Microflex could void the user's authority to operate this equipment.

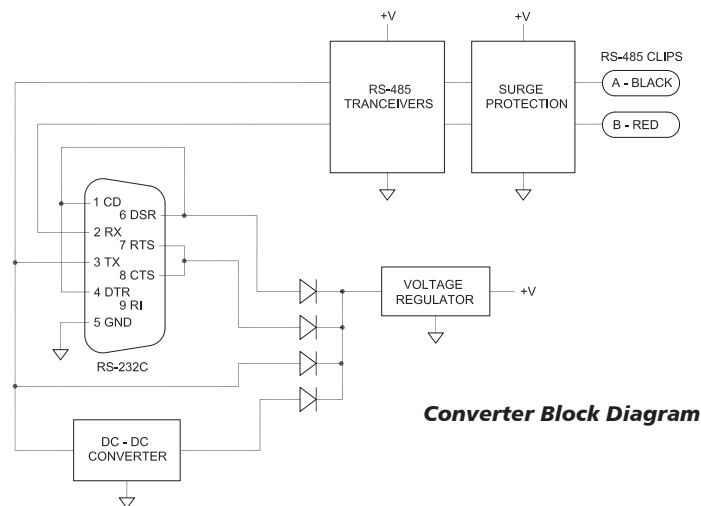

Limited Warranty

Microflex, LLC warrants this unit against defects in materials and workmanship for a period of one year from the date of shipment. Microflex, LLC will, at its option, repair or replace equipment that proves to be defective during the warranty period. This warranty includes parts and labor.

A Return Materials Authorization (RMA) number must be obtained from the factory and clearly marked on the outside of the package before equipment will be accepted for warranty work.

Microflex, LLC believes that the information in this manual is accurate. In the event that a typographical or technical error exist, Microflex, LLC reserves the right to make changes without prior notice to holders of this edition. The reader should consult Microflex, LLC if any errors are suspected. In no event should Microflex, LLC be liable for any damages arising out of or related to this document or the information contained in it.

EXCEPT AS SPECIFIED HEREIN, MICROFLEX, LLC MAKES NO WARRANTIES OR MERCHANTABILITY OR FITNESS FOR A PARTICULAR PURPOSE. CUSTOMER'S RIGHT TO RECOVER DAMAGES CAUSED BY FAULT OR NEGLIGENCE ON THE PART OF MICROFLEX SHALL BE LIMITED TO THE AMOUNT THEREFORE PAID BY THE CUSTOMER. MICROFLEX, LLC WILL NOT BE LIABLE FOR DAMAGES RESULTING FROM LOSS OF DATA, PROFITS, USE OF PRODUCTS, OR INCIDENTAL OR CONSEQUENTIAL DAMAGES, EVEN IF ADVISED OF THE POSSIBILITIES THEREOF. This limitation of the liability of Microflex, LLC will apply regardless of the form of action, whether in contract or tort, including negligence. Any action against Microflex, LLC must be brought within one year after the cause of action accrues. The warranty provided herein does not cover damages, defects, malfunctions, or service failures caused by owners failure to follow Microflex, LLC's installation, operation, or maintenance instructions; owners modification of the product; owner's abuse, misuse, or negligent acts; and power failure or surges, fire, flood, accident, actions of third parties, or other events outside reasonable control.

Microflex, LLC
 2202 Red Bird Lane
 Brookshire, Texas 77423
 USA

Phone 281-855-9639
 Fax 832-422-4391
www.microflx.com

The HART protocol is supported by the HART Communications Foundation in Austin Texas, www.hartcomm.org. HART is a registered trademark of the HART Communications Foundation.