

**SEM11 MOTOR**  
 Energy efficient European Motor  
 Internal installation

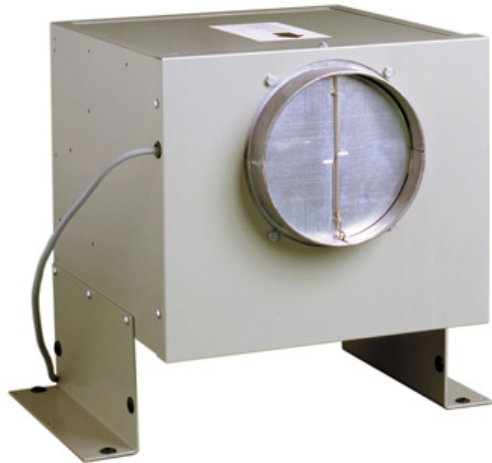

Motor install type	Inside the house
Ducting diameter	150mm
Extraction	1200m <sup>3</sup> /h
Electrical requirement	10A
Power absorption	270W
Pressure	590Pa
Noise	64 dBA
	Aluminium die cast
Dimensions (mm)	W302 x D302 x H255
Warranty	10 years



Internal Motor Configuration

Inside the house installation:

These motors can be installed a maximum of 7 metres away from the hood, with the optimum performance being 2-5 metres from the hood. From the motor to the exit point to the atmosphere, an additional 5 metres of ducting can be used.

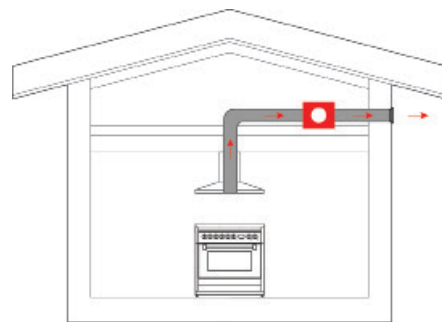
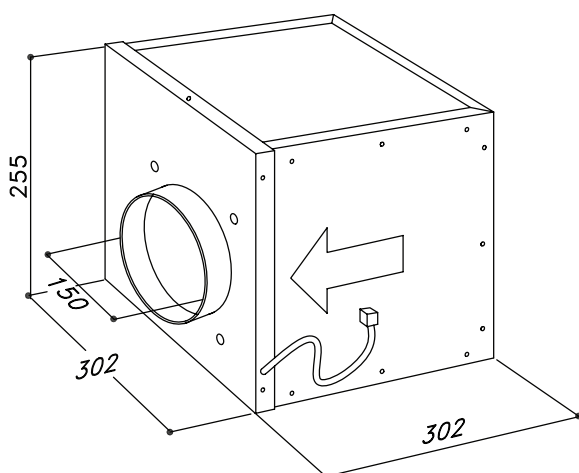

Shown with wall vent.  
 (Also available in roof or eave vent.)

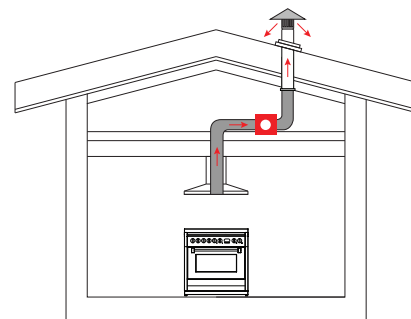

Shown with roof vent.  
 (Also available in wall or eave vent.)

- Use semi-rigid or rigid ducting, not fully flexible foil ducting.
- Fewer bends means a quieter and more powerful extraction.
- Extra 3 years warranty on Sirius rangehood when Sirius ducting is used (total 6 years).
- See [support page](#) on Sirius website for installation videos and FAQs.

WARNING: technical specifications and product sizes can be varied by the manufacturer, without notice. Cut outs for appliances should only be by physical product measurements. The above information is indicative only.

Distributed by Arisit Pty Ltd

40-50 Mark Anthony Drive, Dandenong South VIC 3175

Ph: 1300 762 219

Fax: 03 9768 0838

Website: [www.arisit.com](http://www.arisit.com)

[www.siriusbrand.com](http://www.siriusbrand.com)