

Valvulas de Compuerta ANSI 150 con cierre de EPDM y Cuerpo de Función Nodular GGG50 recomendado para plantas de tratamiento de aguas residuales, Estaciones de agua potable y sistemas de riego agricola.

Mantenimiento nulo.

Temperatura de trabajo: 10°C a 80°C

Diseño: **AWWA C515-09**

Cuerpo: Hierro Nodular GGG50

Diseño DIN 3202 F4

Cara a cara: ANSI B16.10 Clase 150

Bridas: ANSI 150

Sellos: EPDM

Vastago: SS420

W.P 250 psi

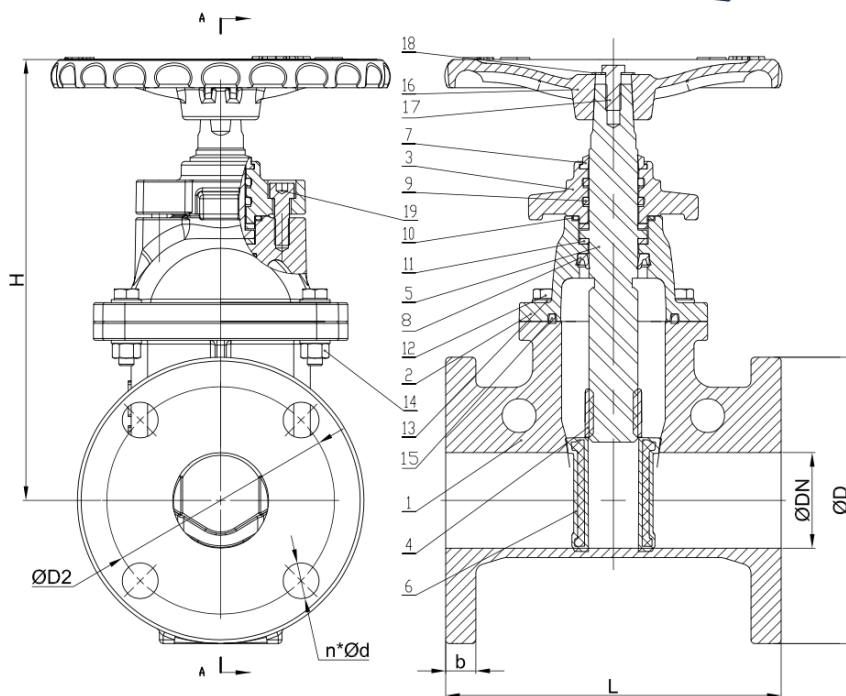

ANSI	L	D	D1	D2	b	H
DN50 2"	177.8	152	50.8	120.7	15.9	234
DN65 2 1/2"	190.5	178	65	139.5	17.5	254
DN80 3"	203.2	191	80	152.5	19.1	293
DN100 4"	228.6	229	100	190.5	23.9	328
DN125 5"	254	255	125	216	22.3	382
DN150 6"	267	280	152.4	241.5	23.9	430
DN200 8"	292	343	203	298.5	28.6	519
DN250 10"	330.2	406	254	362	30.2	609
DN300 12"	355.6	483	304.8	432	31.8	685

ANSI	L	D	D1	D2	b	H
DN350 14"	533	476	413	381	35	770
DN 400 16"	597	539.5	470	406	37	845
DN 450 18"	635	577.9	533	432	39.7	925
DN 500 20"	699	635	584	457	43	1000
DN 600 24"	813	749.5	692	508	48	1155