



M20 Pro

Self-Cleaning Robot Vacuum and Mop Owner's Manual



support@lynkbey.com



www.lynkbey.com

Please read through the Manual before using the product, and keep it properly.

Embracing Technology for Warmer Life

Welcome

Thank you for choosing LYNKBHEY.

This Manual gives a brief introduction to the Robot Vacuum and Mop (hereinafter referred to as the "Robot"), provides guidance on quick installation, and specifies important information on the use and maintenance, so as to help you to get the best product experience.

If you have any questions during the use, please contact us , LYNKBHEY technical support team always at your service to answer all questions you may have.

 **support@lynkbey.com**

 **www.lynkbey.com**

 **@Lynkbey**

 **@Lynkbey**

Scan the QR code or search in the App store to download "LINKBEY" APP, and connect the robot to unlock more functions.



Scan this QR code for step by step videos

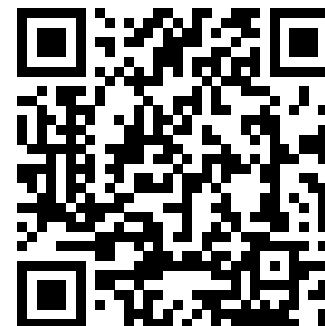

- Photos are for reference only, and the details of actual product may be slightly different.

Safety Information

Use Restriction

- The product is intended for household floor cleaning only, do not use it outdoor (such as open balcony), or on other surfaces than floors (such as sofa), or in commercial or industrial environment.
- Do not sit or stand on the robot or the Docking Station (hereinafter referred to as "dock").
- Do not lift and hold the bottom plate of the dock for moving to avoid the risk of dock falling.
- Do not place any items on the cleaning base of the dock.
- Do not add any unauthorized cleaning solution/disinfectant to the water tank, otherwise it may cause serious damage to the robot and the dock.
- Do not use the product in a room where an infant or child is sleeping.
- Do not put your fingers in the gap to avoid injury.
- Do not use the robot to clean shag rugs (it may be unable to clean some rugs in dark color normally).
- Make sure to clean or maintain the robot and the dock in the power off state.
- Remove all cables on the ground before use so as to prevent the robot from dragging the cables around during running.
- Do not treat the robot and the dock as toys, please supervise children and pets and keep them away from the robot when it is working.
- Do not use the robot to clean any burning objects (such as burning cigarette butts, matches, ashes, etc.).
- Do not store or use the product in an environment above 40°C or below 0°C, or on a surface with any liquid or viscous liquid.
- Do not let any person or pet approaching the rotating position of the brush when the robot is working so as to avoid injury.
- Do not use the device on a suspended place (such as duplex floor, open balcony, furniture top) without guardrail.
- Do not place small objects, such as floor mats and shoes, at stair edges or other places where the robot may easily fall off. Otherwise, it may interfere with the cliff sensor of the robot and result in falling off of the robot.
- All hard or sharp objects (such as decoration wastes, glass, nails, etc.) shall be removed from the floor to be cleaned, otherwise, the robot and the floor may be scratched.
- Make sure the floor to be cleaned is free of water; otherwise, water may enter the robot and result in damage.
- Do not use the device to clean or vacuum any inflammables and explosives (such as lighters, gasoline, color matching agents and toners used in printers or copiers, etc.).
- Make sure to place the dock indoor on a level ground, and away from open flame, heat source, water, narrow area, or area where the robot is subjected to easy suspension.
- Do not use the laser ranging sensor protective cover, robot top cover, collision bumper, dock top cover, water bin handle and other parts as handles to move the device.
- Please remove all fragile objects and clutters (such as vases, plastic bags, etc.) from the floor, so as to prevent the robot from being hindered during working and to avoid damage to valuable articles in your home due to collision.
- Please use the product in accordance with the instructions in the Manual. Any loss and injury caused by improper use shall be borne by the user.

Battery and Charging

- This product can only be charged with the LB2206 Docking Station.
- Make sure that a qualified power supply reliably grounded is used, otherwise, it may result in electric shock and other hazards.
- If no reliably grounded power supply is available, correction shall be made by a professional electrician before using the product.
- Do not disassemble, repair or modify the battery and the dock unless instructed to do so.
- Please disconnect the power plug if the dock will not be used for a long time.
- Waste batteries shall be submitted to professional recycling institute for disposal, discarding at will is prohibited.
- Do not use any third-party batteries, chargers, charging cables or docks.
- Do not wipe or clean the contacts of the dock with a wet tissue, a wet cloth or wet hands.
- Make sure the use the product in an environment where the supply voltage is consistent with the voltage marked on the dock.
- Where product transport is required, please make sure the product is in the power off state, and it is recommended that the original packaging box should be used.
- Only use the power cord that comes with your product. Otherwise, it may result in hazards such as smoke, heat, or fire.
- If the area is susceptible to thunderstorms or the power supply voltage is unstable, appropriate protective measures should be taken.
- The product may not be used with any type of power converter. Use of power converters will immediately void the warranty, and may result in hazards.
- Do not use damaged power cord. If the power cord is damaged (including broken skin or breakdown), stop using it immediately and contact our customer service.
- If the robot will be left unused for a long period, fully charge the robot, turn it off and store it in a cold and dry place. Make sure to charge the robot at least every 3 months so as to avoid over-discharge of the battery.

Laser safety information

- The laser ranging sensor contained in the product complies with the standard for Class 1 laser products according to IEC 60825-1:2014, which will not produce any hazardous laser radiation.

Warning

- This appliance can to be used by children aged from 8 years and above and persons with reduced physical, sensory or mental capabilities or lack of experience and knowledge, if they have been given supervision or instruction concerning use of the appliance in a safe way and understand the hazards involved . Children should not play with the appliance. Cleaning and user maintenance should not be made by children without supervision.

FCC Statement

This device complies with part 15 of the FCC Rules. Operation is subject to the following two conditions: (1) This device may not cause harmful interference, and (2) this device must accept any interference received, including interference that may cause undesired operation.

Any changes or modifications not expressly approved by the party responsible for compliance could void the user's authority to operate the equipment.

Note: This equipment has been tested and found to comply with the limits for a Class B digital device, pursuant to part 15 of the FCC Rules. These limits are designed to provide reasonable protection against harmful interference in a residential installation. This equipment generates uses and can radiate radio frequency energy and, if not installed and used in accordance with the instructions, may cause harmful interference to radio communications. However, there is no guarantee that interference will not occur in a particular installation. If this equipment does cause harmful interference to radio or television reception, which can be determined by turning the equipment off and on, the user is encouraged to try to correct the interference by one or more of the following measures:

- Reorient or relocate the receiving antenna.
- Increase the separation between the equipment and receiver.
- Connect the equipment into an outlet on a circuit different from that to which the receiver is connected.
- Consult the dealer or an experienced radio/TV technician for help.

RF exposure information

The Maximum Permissible Exposure (MPE) level is calculated based on a distance of $d=20$ cm between the device and the human body. To maintain compliance with the RF exposure requirement, a separation distance of 20 cm between the device and the human should be maintained.

Product Introductions

Parts List

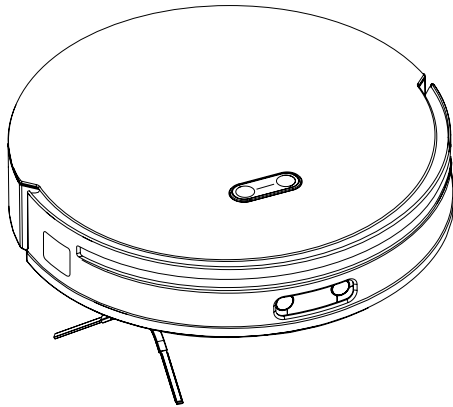

Robot

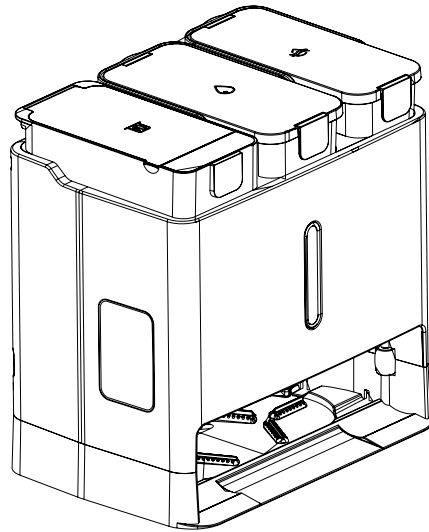

Docking Station
Disposable dust bag

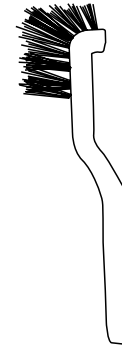

Cleaning brush

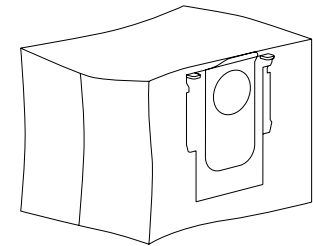

Disposable dust bag
Installed in factory *1
Replacement *1

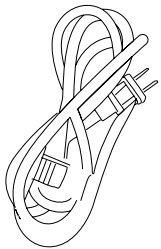

Power cord

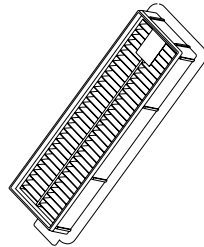

HEPA*2
Installed in factory *1
Replacement *1

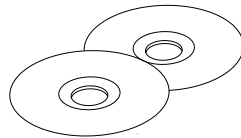

Mopping cloth *2 pair
Installed in factory *1 pair
Replacement *1 pair

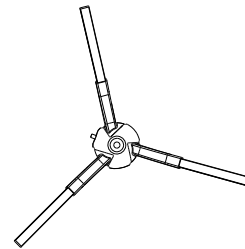

Edge sweeping
brush
Installed in factory *1
Replacement *1

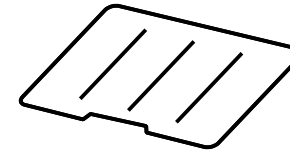

Quick Start Guide



Owner's Manual

Product Introductions

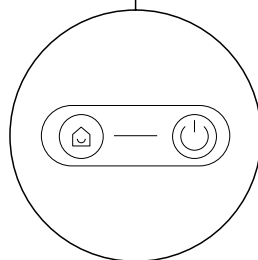
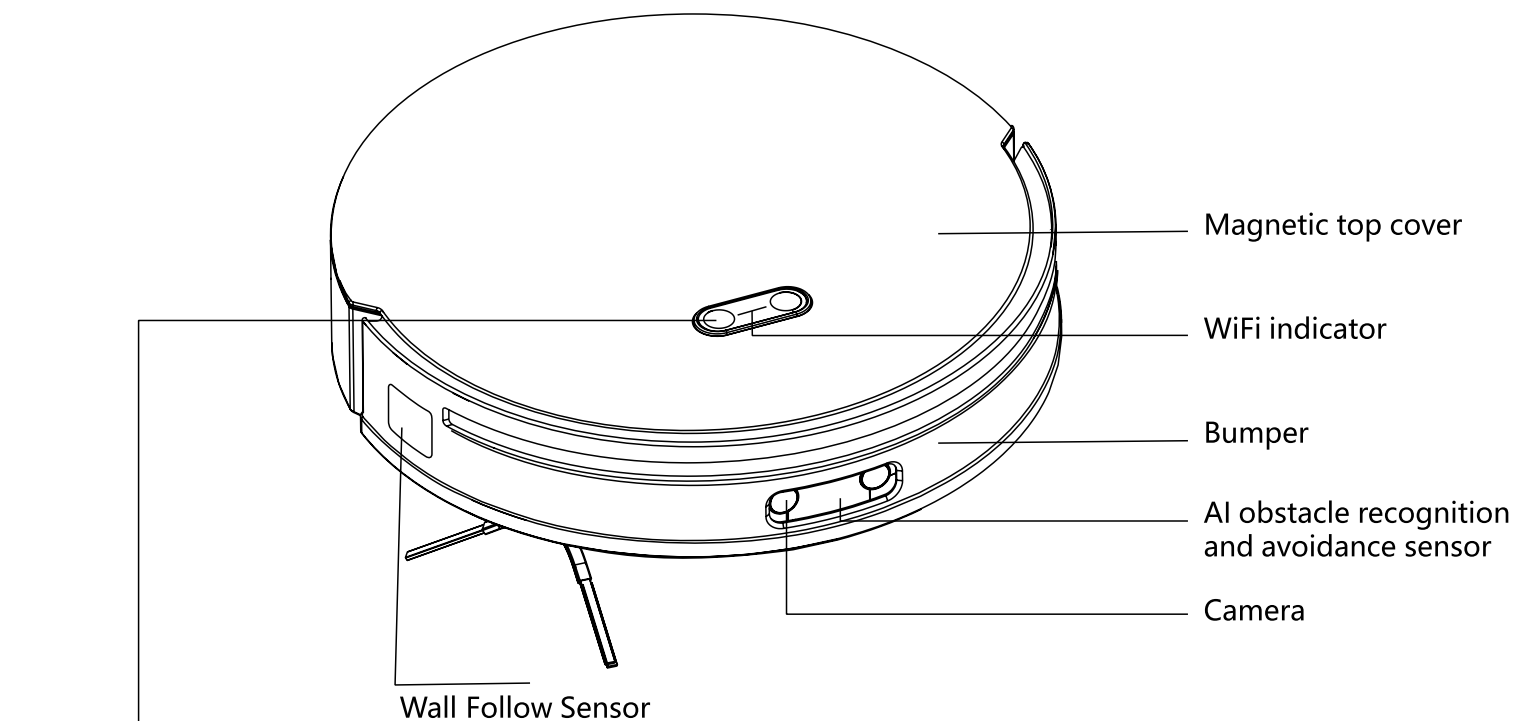

Robot



Home Button:
Press: Return to the dock for charging
Press and hold for 10s: Restore to factory setting



Start/Stop Button:
Press: Start/Stop
Press and hold for 3s: Exit current mode

Press  Start /Stop button and  Home button simultaneously for 3 seconds: Start network configuration

Product Introductions

Robot

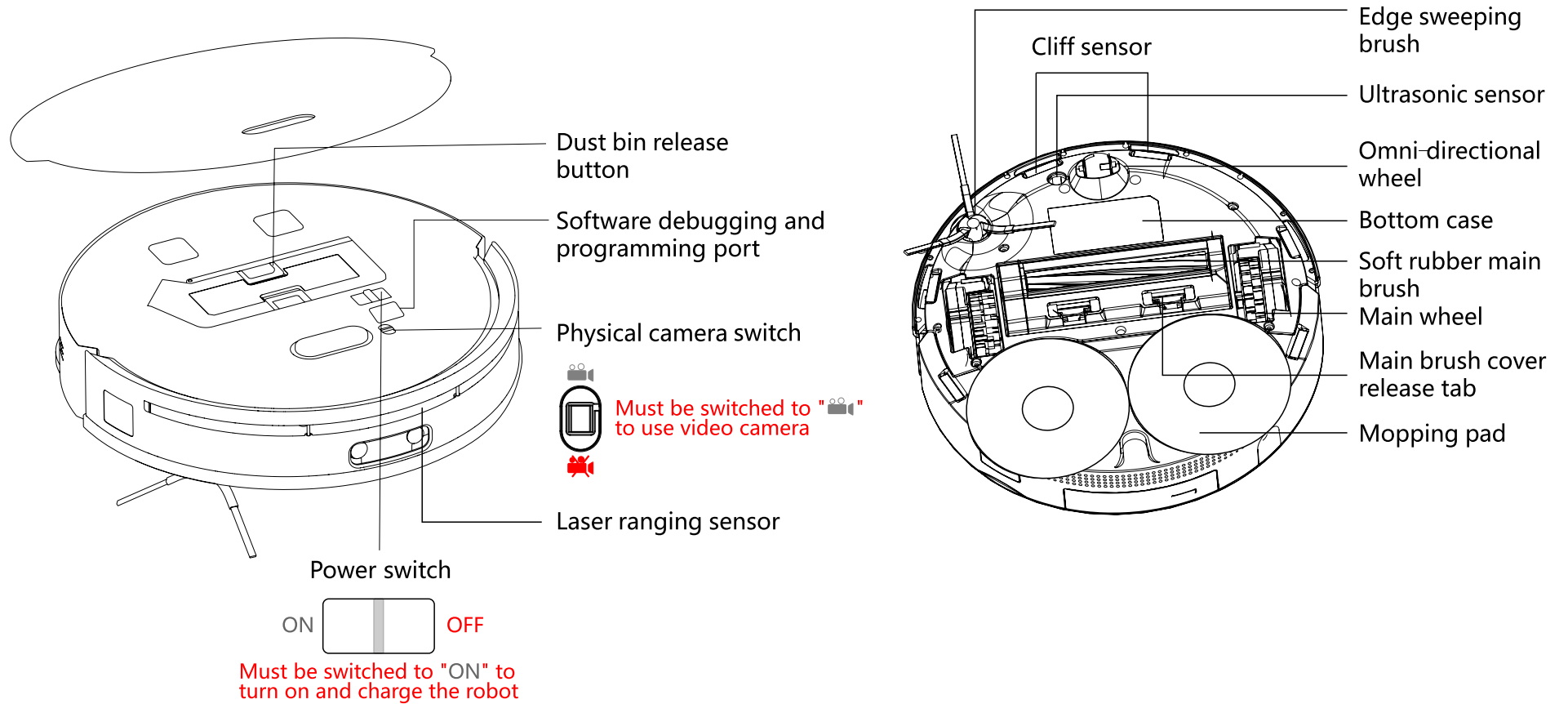

Product Introductions

Robot

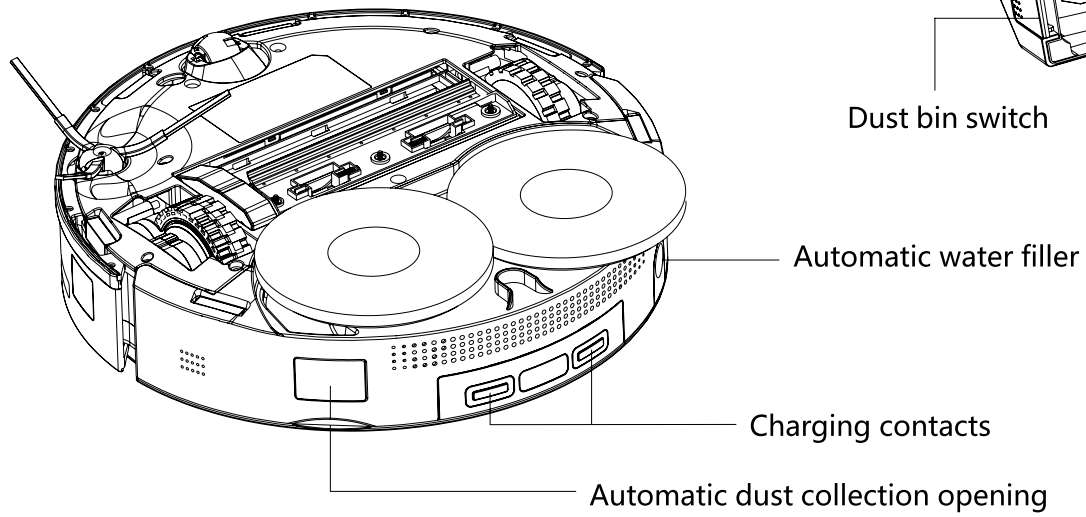

Dust bin

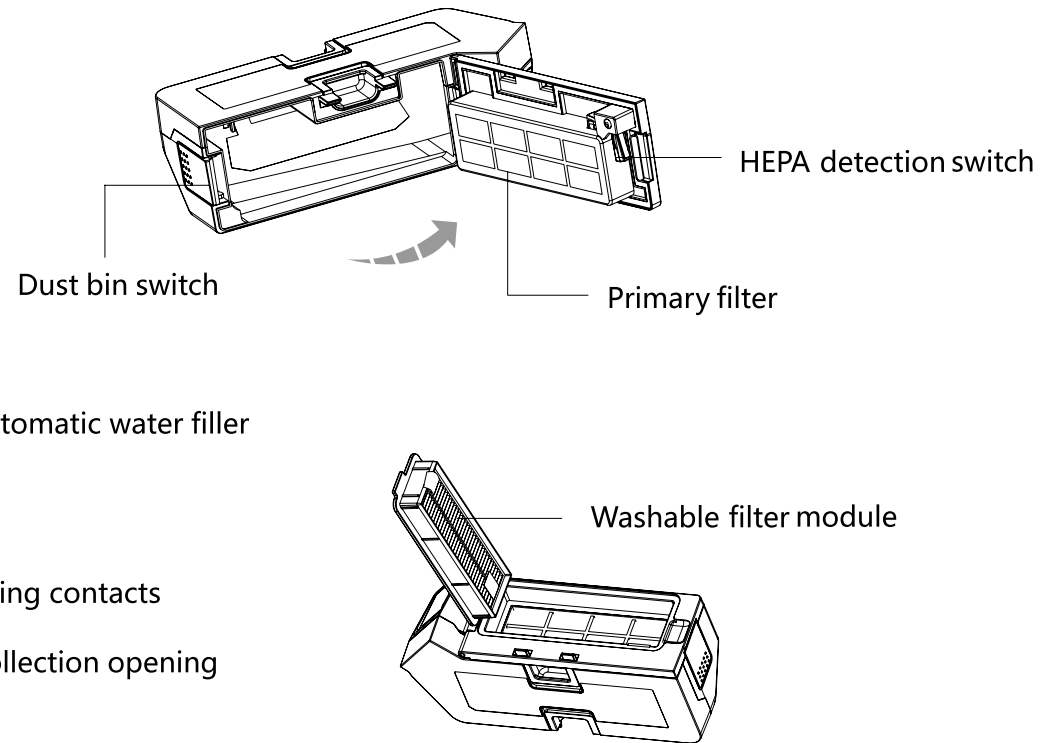

Product Introductions

Dock

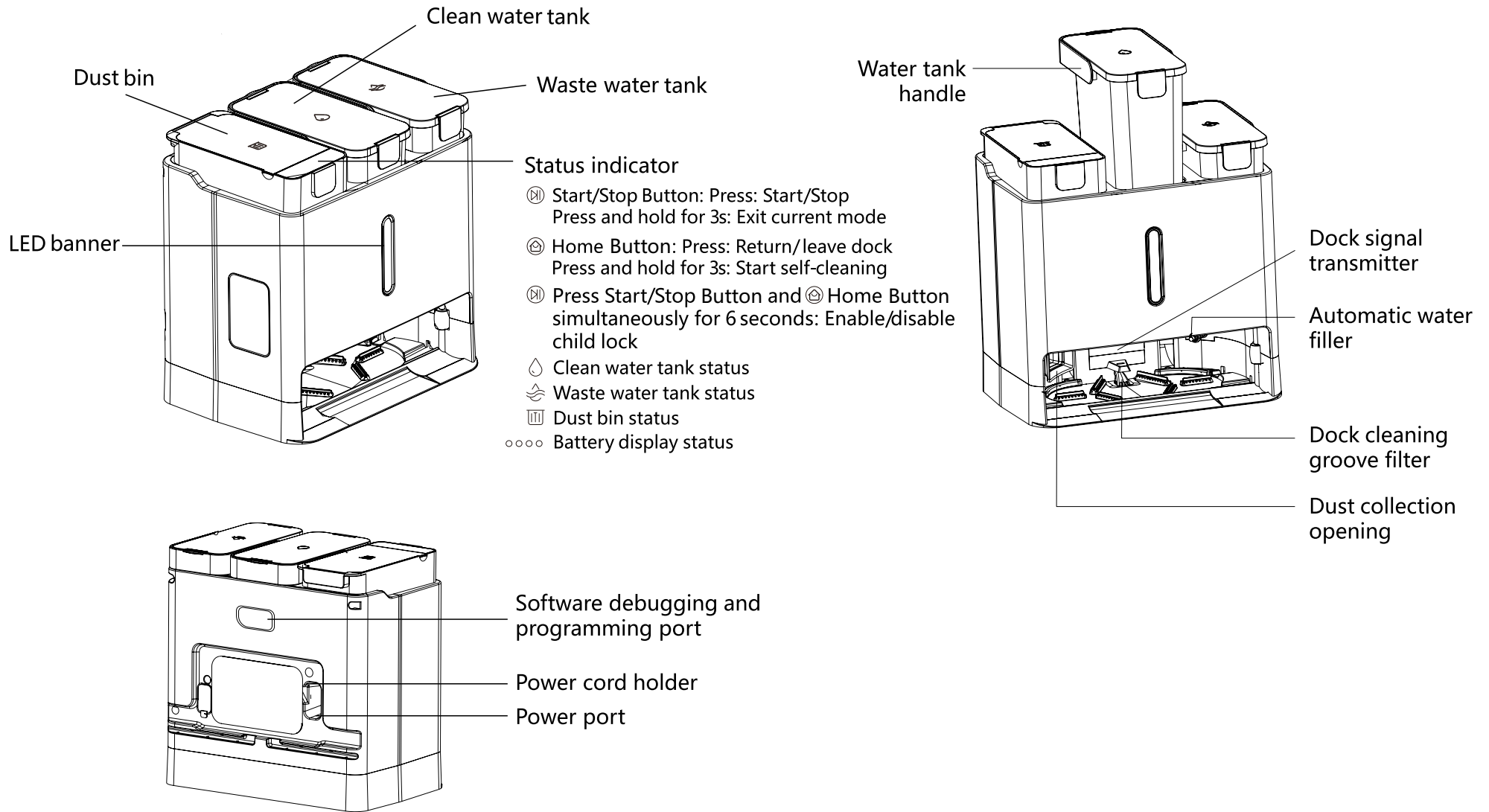

Product Introductions

WARNING

1. Clear up clutter such as wires, hard and sharp objects (such as nails and glass) scattered on the floor, and remove all easily knocked down objects, fragile and valuable objects and other objects that may cause hazards before starting the device, so as to prevent the same from being entangled, stuck, dragged or knocked down by the robot, resulting in personal injury or property damage.

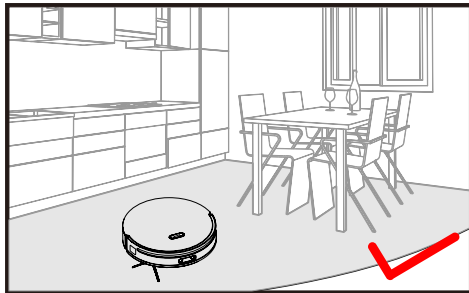
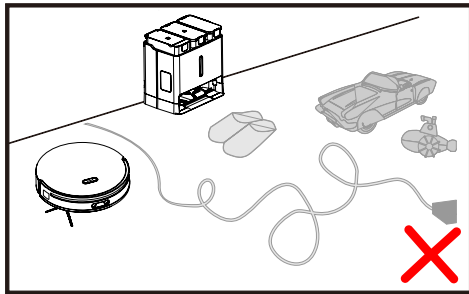

2. If the device is used in a suspension environment, make sure that a reliable physical barrier should be used to prevent accidental falling of the robot and resulting in personal injury or property damage.

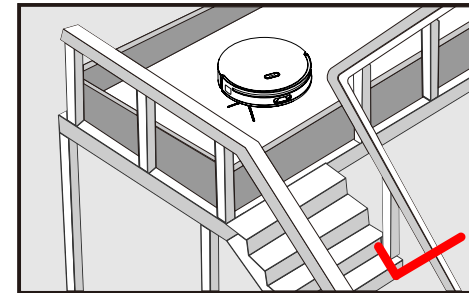
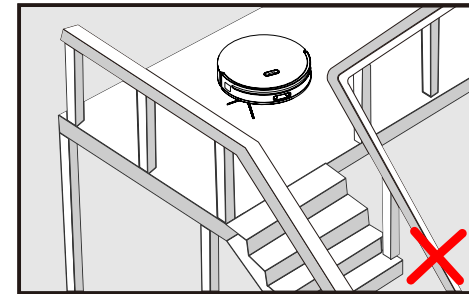

Tips:

- During the first cleaning process, it is recommended to follow the robot throughout the whole process to deal with some potential problems, so as to ensure smooth cleaning in the future.
- If some areas do not need to be cleaned or may cause robot stuck, you can set an exclusion zone in the mobile APP to prevent the robot from entering the above areas.
- Do not use the robot to pick up hard or sharp objects (such as decoration wastes, glass, nails, etc.), otherwise, the robot and the floor may be scratched.

Product Installation

Assembly

1. Place the dock on a hard and level ground.

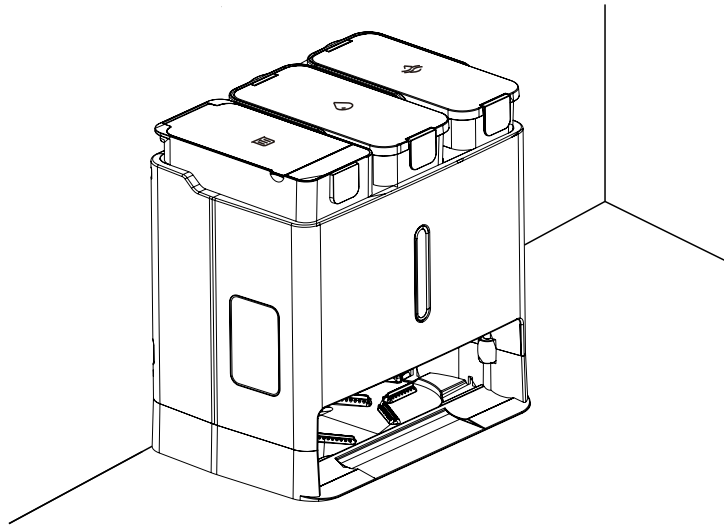

2. Plug the power cord in place as shown in the figure, check and confirm the indicator on the dock lights up, and wrap excess wire back to the cable holder according to the actual condition.

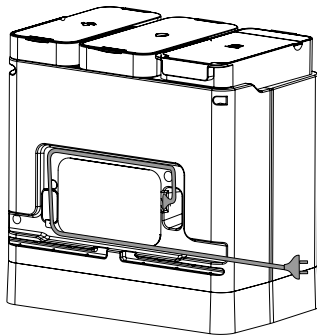

Tips: The power cord can be led out from both the left and the right side of the cord holder.

Positioning the dock

Place the dock on a hard and level ground (such as wood floor, tile, etc.) against a wall, make sure a clearance of 0.5 m is reserved on both sides, and a clearance of 1.5 m is reserved in front. Make sure the place has good WiFi coverage to ensure better mobile APP experience, and then connect the power supply.

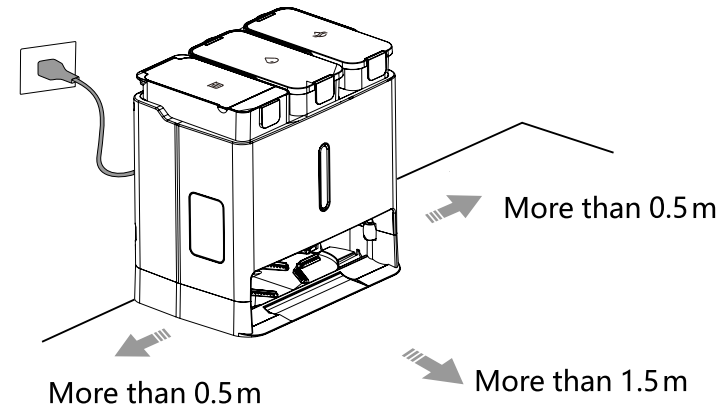

Product Installation

Tips:

- Vertically arranged power cord may be caught and dragged by the robot and result in dock moving or power cut.
- In case an abnormal condition is identified on the dock, the indicator will light up and stay in solid red as warning.
- Make sure to place the dock indoor on a level ground, and away from open flame, heat source, water, narrow area, or area where the robot is subjected to easy suspension.
- Placing the dock on a non-hard ground (such as carpet, floor mat, etc.) may result in tipping over, and the robot may be unable to leave the charging station.
- Do not place the base in direct sunlight, and do not cover the signal transmitting area with any objects, otherwise the robot may be unable to return the dock automatically.
- Do not use the dock without installing the clean water tank, waste water tank, dust bag and cleaning groove filter.
Please maintain the dock properly in accordance with the maintenance instructions, and do not clean the dock directly with a wet cloth or a wet tissue.
- Each dock will be subject to ex-factory test, and a small amount of water inside the water line is a normal phenomenon.

Powering on and Charging

Open the top cover of the robot, remove the anti-collision foam, and turn on the power switch, wait until the Start/Stop button indicator keeps on steadily. Then load the robot onto the dock for charging as shown in the figure. The robot is configured with a high-performance built-in rechargeable lithium-ion battery pack. In order to maintain battery performance, please keep the robot charged during daily use.

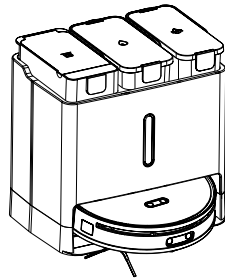

Tips: The device may be unable to be started in case of low battery, in this case, place the robot directly onto the dock.

Use Instructions

Turn ON/OFF

Open the top cover of the robot, remove the anti-collision foam, and turn on the power switch, the power indicator will light up, wait for the robot system to start up, and the robot will enter the standby state.

Turn off the power switch, the robot will shut down directly.

Tips: The robot cannot be charged when it is turned off.

Connecting to Mobile APP

1. Download " LINKBEY " App to experience more functions:

Method I: Open "Scan" on your mobile phone, scan the QR code on the robot, and download and install the APP free of charge according to the prompt guide.

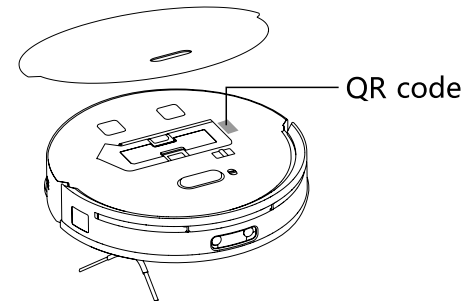

Method II: Open the App store on your mobile phone, search for " LINKBEY ", and download and install the App.

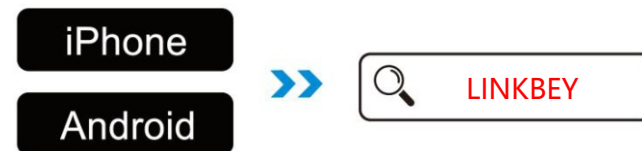

Use Instructions

2. Reset WiFi

a. Press Start/Stop button and Home button simultaneously for 3 seconds until a voice prompt of "start network configuration" is heard, and wait until the WiFi indicator starts flashing slowly, it indicates that the robot has entered the network configuration mode.

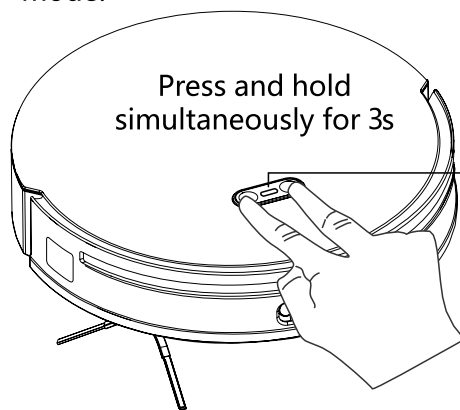

WiFi indicator:

OFF: WiFi disabled

Flashing slowly: waiting for connection

Steady: WiFi connected

Tips: In case of phone-robot connection failure due to router configuration change, password forgotten or other reasons, reset WiFi to enter the network configuration mode, and then add the device as a new device.

3. Add device

Open the mobile APP and enter the home page, click "+" on the page or follow the guide on the page to add your device.

Tips:

- The actual procedure may vary from the above description due to mobile APP updates, please follow the prompt guide in the APP.
- **Only support 2.4GHz WiFi connection.**
- When the robot stays in the "wait for connection" state for 2 minutes, WiFi will be disabled automatically. In this case, reset WiFi for network connection.

Fill water tank

Take out the water tank, open the top cover of the tank, optionally add three caps (about 20ml) of lynkbey cleaning solution (sold separately), and fill the tank with tap water to the MAX mark, then close the top cover of the tank and put the tank back to the dock.

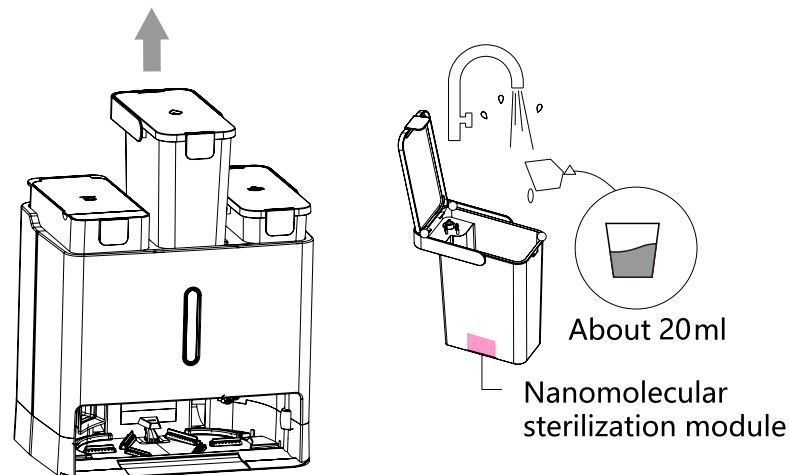

Tips:

- Do not use unauthorized cleaning solution, otherwise, it may corrode the robot and the dock.
- Do not add too much lynkbey cleaning solution, for it may result in robot slippage and hinder the normal cleaning.
- Do not add hot water, for it may result in tank deformation.
- If there is residual water outside the tank, wipe it with a soft dry cloth before putting the tank back.

Use Instructions

Start cleaning and mopping

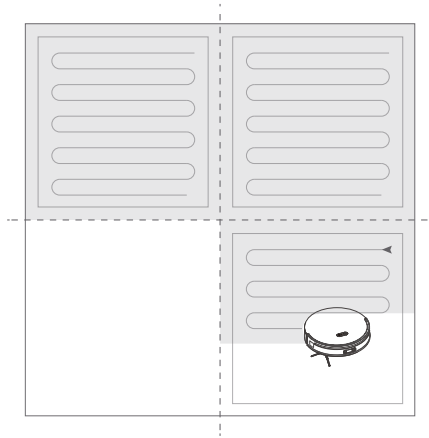

Press  button, the robot will dynamically plan the cleaning route according to the created map. It will first vacuum and mop edges of a zone along walls, then the middle of the zone row by row efficiently. During the cleaning, the robot can judge the time for mopping cloth cleaning and water tank filling automatically, and return to the dock for cloth cleaning and tank filling actively, so as to ensure good mopping effect.



Tips :

- To ensure that the robot can normally return to the dock for mop cloth cleaning, it is recommended that the robot should start and leave the dock in the charging state, and please do not move the dock during the vacuuming and mopping process.
- In the first vacuuming and mopping process, please follow and help the robot to eliminate potential problems.
- In case of low battery, charge the robot before vacuuming and mopping.
- Clear up all kinds of wires (including the power cord of the dock) and valuable articles on the ground to prevent the same from being caught and dragged by the robot during vacuuming and mopping, and resulting in blackout, or damage to articles or wires.
- If the vacuuming and the mopping time is less than 10 minutes, the zone will be cleaned twice by default.
- In case of low battery in the vacuuming and mopping process, the robot will automatically return to the dock for charging, and will automatically return to the stop point and continue the vacuuming and mopping job after sufficiently charged (the continue switch should be turned on in the APP).

Pause

When the robot is working, press  button to pause, press  to resume cleaning, and press  to return to the dock for charging.

Tips: Placing a robot in the pause state back onto the dock will end the current cleaning job.

Sleep

If no operation is detected for more than 10 minutes, the robot will automatically enter the sleep state, and the button light on the dock will go off. Press any key to wake it up.

Tips:

- The robot will enter the sleep state ten minutes after it is fully charged.
- In the non-charging state, the robot will automatically shut down if staying in the standby state for 12 hours.

Do-Not-Disturb mode

The Do-Not-Disturb mode is disabled by default. You can modify the Do-Not-Disturb period or disable the function in mobile APP. In the Do-Not-Disturb period, the robot will not perform the scheduled cleaning task.

Child Lock

Turn on/off method: Press and hold the Start/Stop button and the Home button on the dock simultaneously for 6 seconds or set in the mobile APP. When the child lock is enabled, all buttons of the robot on the dock will be locked.

Use Instructions

Charging

After the cleaning, the robot will automatically return to the dock for charging.

Press  button to start recharging. During charging, the power indicator will breathe and flash.

Tips: If the robot fails to find the dock, it will automatically return to the start point. Please manually place the robot back onto the base for charging.

System resetting

If the robot does not respond when a button is pressured or cannot be turned off, try to turn off the robot and reset system. The robot will reset automatically.

Restore to factory setting

If the robot fails to work normally after system reset, press and hold Home  button on the robot for 10 seconds in the startup state until the voice prompt "starting to restore factory settings" is heard, and the robot will be restored to factory settings.

Tips: After restoring factory settings, relevant functions including scheduled cleaning and WiFi will be restored to the factory settings.

APP Function Introduction

Cleaning map

Multi-map management | real-time vacuuming and mopping route | map zoning|map editing

Custom cleaning mode

Scheduled cleaning | selected zone cleaning | map zoning | remote control mode | restricted zone and virtual wall

Cleaning mode adjustment

Vacuuming and mopping mode | suction power | mop intensity| cleaning water volume

Robot information

Cleaning history | battery level | care and maintenance

More features

Volume adjustment | Do-Not-Disturb mode | video manager

Tips: Features and details are subjected to change due to constant APP development and update.

Routine Maintenance

To maintain the robot in its best performance, it is recommended that routine maintenance shall be performed according to the following table.

Parts	Maintenance frequency	Replacement frequency
Omni-directional wheel	Clean as required	/
Dust bin	Clean as required	/
Soft rubber main brush	Clean every 2 weeks	Every 6-12 months
Edge sweeping brush	Clean every month	Every 3-6 months
Washable filter module	Clean every 2 weeks	Every 6-12 months
Mopping cloth	Clean as required	Every 3-6 months
Dock locating sensor	Clean every month	/
Cliff sensor	Clean every month	/
Wall Follow Sensor	Clean every month	/
Capet detection sensor	Clean every month	/
Main wheel	Clean every month	/
Charging contact	Clean every month	/
Dock charging contacts, signal transmitting area and body	Clean every month	/
Dock cleaning groove filter	Clean as required	/
Clean water tank, waste water tank	Clean as required	/
Disposable dust bag	Replace as required	Every 1-2 months
Nanomolecular sterilization module	Replace as required	Every 12 months

Soft rubber main brush

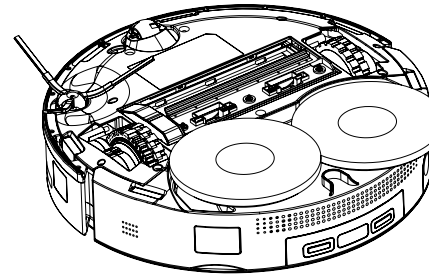
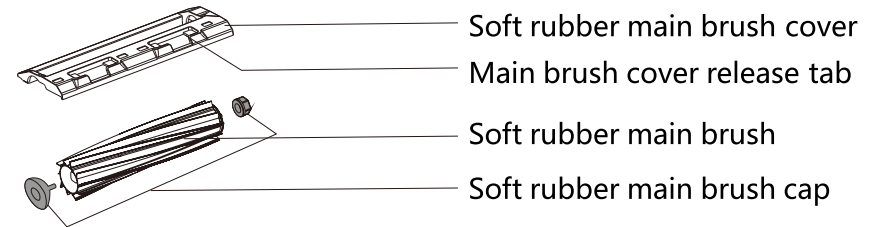

1. Turn the robot upside down, press the tab to remove the main brush cover

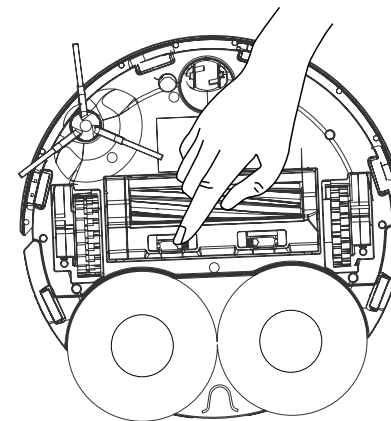

Routine Maintenance

2. Take out the soft rubber main brush, pull out the bearing of the soft rubber main brush, turn and remove the caps of the soft rubber main brush along the marked unlocking direction, remove hairs or dirt tangled on both ends of the soft rubber main brush.

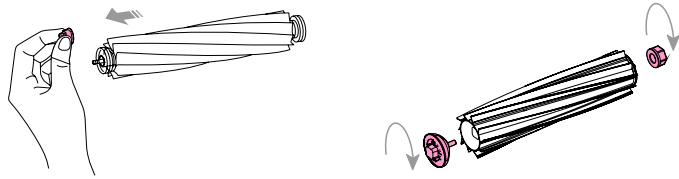

3. Install the soft rubber main brush back onto the robot.

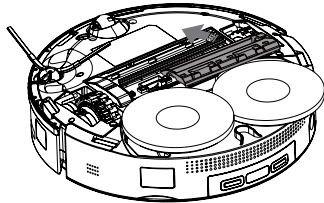

4. Install the soft rubber main brush cover back onto the robot, and make sure 3 teeth of the cover are inserted into the corresponding slots.

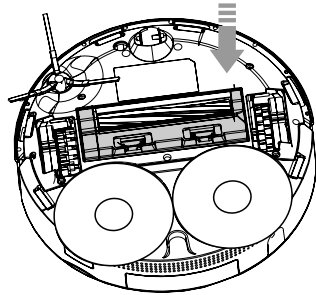

Tips:

- It is recommended that a cloth dipped in warm water should be used for cleaning the main brush. If the brush is immersed in water, make sure to dry the brush naturally and completely, and exposure to direct sunlight must be avoided.
- Do not use corrosive cleaning solution or disinfectant to clean soft rubber main rubber.

Edge sweeping brush

1. Remove the fixing screws of the edge sweeping brush.
2. Clean the edge sweeping brush, and install and tighten the fixing screws.

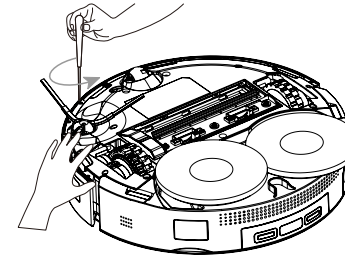

Omni-directional wheel

1. Pry up the omni-directional wheel with a small screwdriver and other tools.

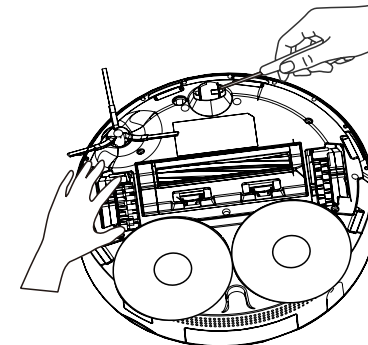

- Tips: The bracket of the omni-directional wheel cannot be removed.
2. Rinse the wheel and the wheel shaft with water to remove hairs and dirt, dry the wheel naturally, install and press it backing place.



Routine Maintenance

Main wheel

Wipe and clean the main wheels with a soft and dry cloth.

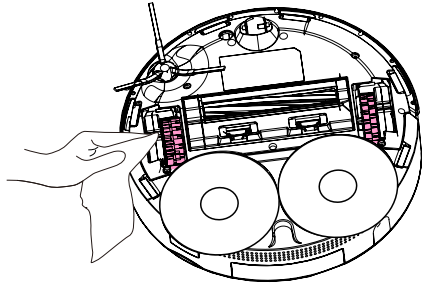

Dust bin

1. Open the top cover of the robot and take out the dust bin.

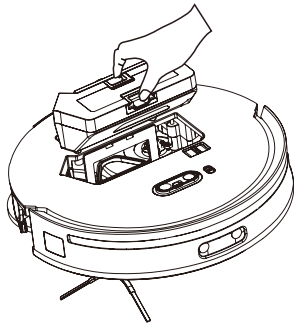

2. Open and empty the dust bin.

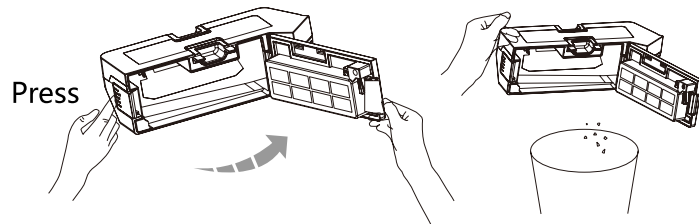

3. Open the dust bin and wash the inside of the dust bin with clean water, and pour out the dirty water.

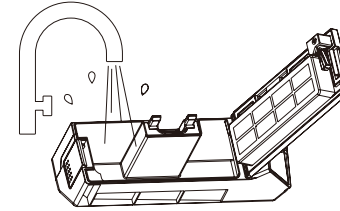

Tips: Do not add any detergent, otherwise, it may result in filter blocking.

4. Dry the dust bin and the washable filter naturally.

Washable filter

1. Open the top cover of the filter and take out the filter.

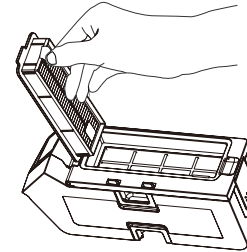

2. Rinse the filter repeatedly and tap it gently to remove dirt.

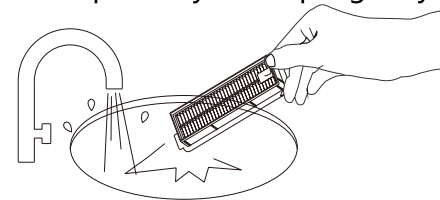

Tips: Do not touch the surface of the filter with your hands, brushes or sharp objects to avoid damage to the filter.

Routine Maintenance

3. Dry the filter naturally and completely and install it back.

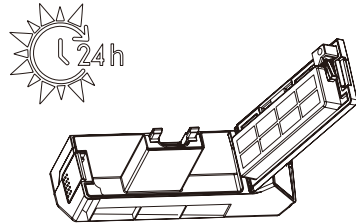

Tips:

- Make sure the filter is dry completely before using.
- It is recommended that the two filters should be used in turn.

Mopping cloth

1. Remove the mopping cloth from the mop bracket.

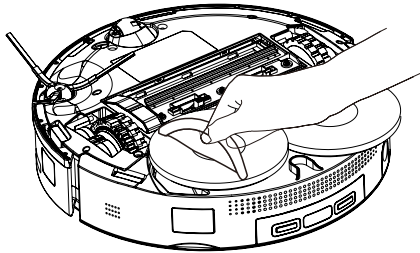

2. Clean and naturally dry the mopping cloth.

Tips: A dirty mopping cloth will influence the cleaning effect, please clean the cloth before using.

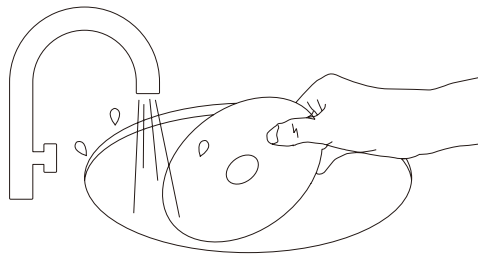

3. Attach the mopping cloth to the mopping cloth bracket along the edge.

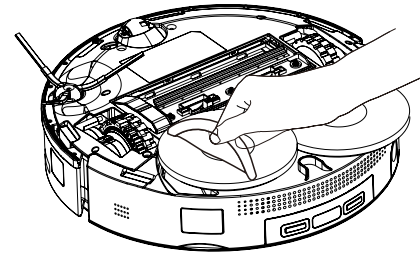

Robot sensor

Wipe and clean all sensors on the robot with a soft and dry cloth, including

1. Front dock locating sensor, obstacle avoidance sensor, camera.
2. Rear dock locating sensor and two charging contacts
3. Right wall follow sensor
4. Bottom carpet detection sensor and six cliff sensors

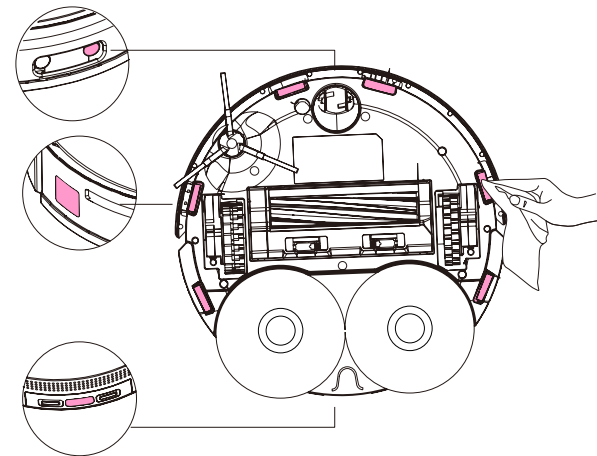

Routine Maintenance

Moving charging station

Where moving the dock is required, hold the handle on the back with one hand, and hold the inner side of the front side, and lift the dock for moving as shown in the figure. Do not lift and hold the bottom plate of the dock for moving to avoid the risk of dock falling.

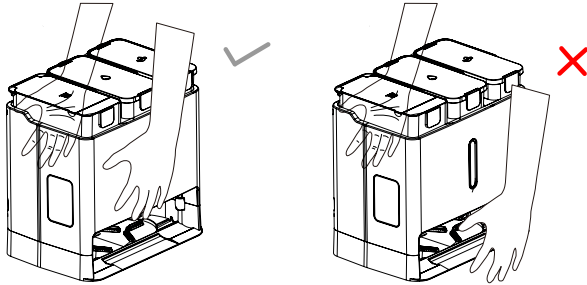

Water tank

Regularly clean the waste water according to the use condition. Open the top cover of the waste water tank to pour out dirty water, fill the tank with tap water, close and tighten the cover, and shake the tank. After cleaning, pour out the dirty water, close the top cover of the tank, and install it back.

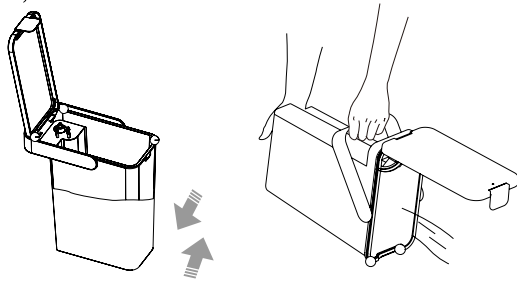

Tips :

- Do not use unauthorized cleaning solution, otherwise, it may corrode the robot and the dock.
- Do not add too much lynkbey cleaning solution, otherwise, it may result in robot slippage and hinder the normal cleaning.
- Do not add hot water, for it may result in tank deformation.
- If there is residual water outside the tank, wipe it with a soft dry cloth before putting the tank back.

Charging contact area

Wipe and clean the charging contacts of the dock with a soft and dry cloth.

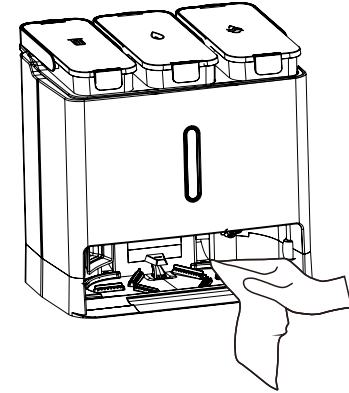

Cleaning clean groove

Clean the clean groove with the cleaning brush supplied along with the product, and clean and wipe the clean groove with a soft cloth.

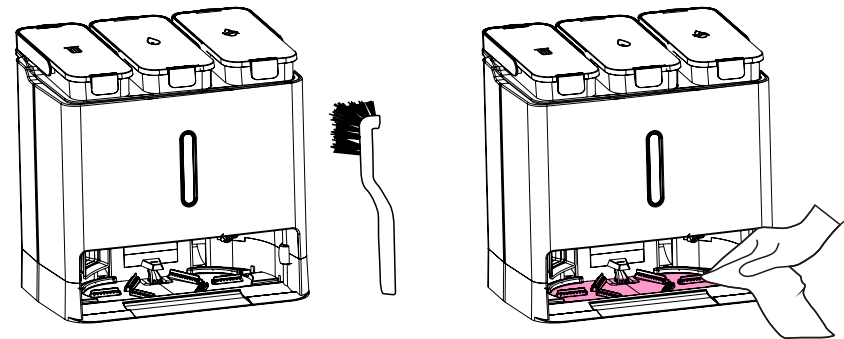

Routine Maintenance

Cleaning clean water tank filter cotton

1. Open the cover of the clean water tank, pull out the suction head, gently open the small cover and take out the filter.
2. Wash it with clean water and install back onto the suction head.

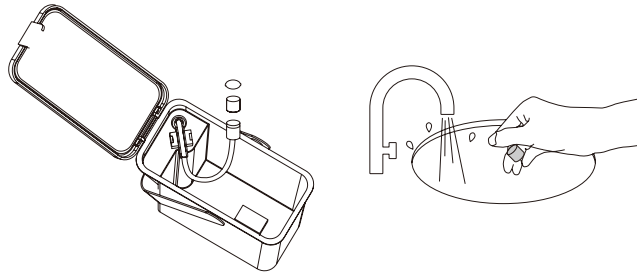

Replacing disposable dust bag

Tips: Please replace the disposable dust bag regularly.

1. Open the cover of the dust collection tank.
2. Remove the disposable dust bag vertically along the arrow direction and discard it.

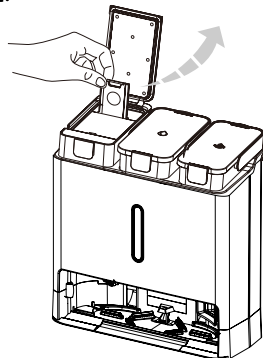

Tips:

- When removing, the dust bag handles can close and seal the dust bag, which effectively avoid dust leakage.
- Do not close the top cover of the dust collection tank without loading a dust bag, so as to avoid automatic dust collection without a dust bag.

3. Clean the periphery of the filter with a dry cloth, insert a new dust bag to the slot and press in place as shown in the figure.

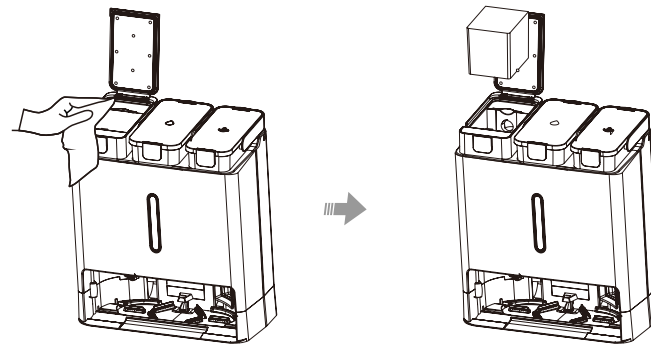

Tips: Make sure the disposable dust bag is reliably sealed so as to avoid garbage leakage and result in dock damage.

4. Close the dust collection tank, and make sure it is fully sealed.

Cleaning dock cleaning groove filter

1. Pull out the dock cleaning groove filter vertically.
2. Wash the dock cleaning groove filter with clean water.
3. Align the dock cleaning groove filter with the mounting position and insert it vertically.

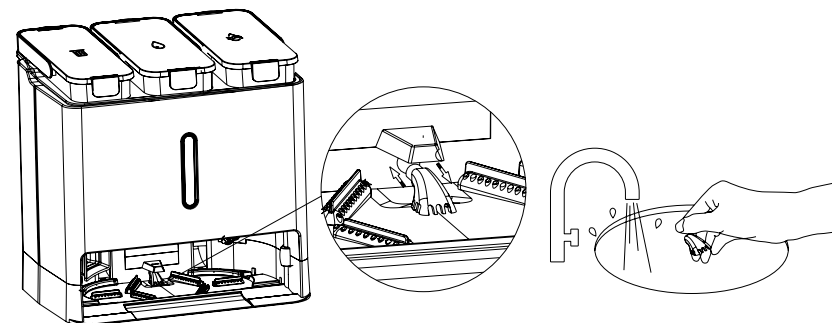

Basic Parameters

Self-Cleaning Robot Vacuum and Mop	
Product model	M20 Pro
Battery	14.4V/5200 mAh Li-ion battery
Weight	3.92kg
Wireless connection	2.4 GHz WiFi smart connection
Rated voltage	14.4V \equiv
Rated power	72W
Charging time	<7 hours
Docking Station	
Product model	LB2206
Rated input	100V-120V~50/60Hz
Rated input current (charging state)	0.3A
Rated output	20V \equiv 3.0 A
Power (Auto-Wash state)	35W
Power(Auto-Empty state)	1000W

Environment Protection Information

Procedure for removing battery• the following information is not provided as daily operation instructions, which applies only when the robot is to be discarded

The built-in lithium-ion battery contains chemicals that may cause environmental pollution. Please remove the battery before discarding the product, and submit the battery to a professional battery recycling facility for centralized disposal.

1. Run the robot without letting it connect with the dock until it can no longer perform cleaning task due to low battery.
2. Turn off the robot.
3. Remove the screws of the battery cover of the robot.
4. Remove the battery cover.
5. Press the latch, pull out the battery connector and remove the battery.

Warning:

- Before removing the battery, make sure it is fully discharged, and the robot is not in contact with the dock.
- Remove the entire battery pack, pay attention not to damage the battery pack casing, so as to avoid short-circuit or leakage of hazardous substance.
- In the event of accidental contact with battery fluid, rinse thoroughly with plenty of water and seek medical attention immediately.

WEEE Information

All products bearing this symbol are waste electrical and electronic equipment (WEEE as in directive 2012/19/EU) which should not be mixed with unsorted household waste. Instead, you should protect human health and the environment by handing over your waste equipment to a designated collection point for the recycling of waste electrical and electronic equipment, appointed by the government or local authorities. Correct disposal and recycling will help prevent potential negative consequences to the environment and human health. Please contact the installer or local authorities



Troubleshooting

Robot fault

The power indicator on the robot is in flashing red with a voice alarm generated, please follow the voice prompt and the APP guide to eliminate the fault.

Tips

- In the fault state, if no operation is detected in 10 minutes, the robot will enter the sleep state automatically.
- In the fault state, placing a robot back onto the dock will end the current cleaning job.

Docking Station fault

The indicator on the dock is in solid red with a voice alarm generated, please follow the voice prompt and the APP guide to eliminate the fault.

If the fault cannot be eliminated

Please contact our customer service:

Email: support@lynkbey.com

Note: Our company reserves the right to make any technical and design changes to our products for the purpose of constant product improvement.

FAQs

Problem	Solution
Unable to start up	<ul style="list-style-type: none"> • Low battery, please place the robot on the dock for charging before use; • High or low battery temperature, Only use the robot within the range of 0-40°C(39-104°F).
Unable to charge	<ul style="list-style-type: none"> • The dock is not connected to power supply, check and confirm the two ends of the power cord is properly connected; • Poor contact, clean the charging contacts on the dock and on the robot; Check whether the indicator on the dock is on.
Low charging speed	<ul style="list-style-type: none"> • When using in a high or low temperatures environment, the robot charging speed will decrease automatically to prolong the service life of the battery; • The charging contact area is dirty, clean the area with a dry cloth.
Unable to return to the dock for charging	<ul style="list-style-type: none"> • There are too many obstacles around the dock, place the dock in an open area; • The robot is too far away from the dock, move the robot to a place near the dock and try again.
Abnormal noise during cleaning	<ul style="list-style-type: none"> • The main brush, the edge-sweeping brush or the main wheels may be stuck by foreign matters, turn off the device and clean the same. • Dust enter the omni-directional wheel during cleaning or the wheel is struck by foreign matters, pry up the wheel with a screwdriver and wash it.
WiFi connection failure	<ul style="list-style-type: none"> • WiFi is not enabled, reset WiFi and try again; • The WiFi signal is bad, move the robot to an area with good WiFi reception; • Abnormal WiFi connection, reset WiFi and download the latest mobile client, and try again; • WiFi connection suddenly unavailable, There may be an error with your router settings, contact customer support for fault elimination.
Whether the robot consuming power when it stays on the dock	<ul style="list-style-type: none"> • The robot consumes extremely low power when it is stays on the base, which can maintain the battery at its optimal performance.
Does the robot need to be charged for at least 16 hours for the first three uses?	<ul style="list-style-type: none"> • No. The lithium battery has no memory effect, so the robot can be used after it is fully charged and there is no need to wait for 16 hours.
Robot failure to resume the cleaning task after returning to the dock for recharging due to low battery in the cleaning process	<ul style="list-style-type: none"> • Check and confirm the robot is not in the Do-Not-Disturb mode, the robot will not resume the cleaning task in this mode; • The robot will not resume the cleaning task when it is placed back to the dock manually.
Sudden robot failure	<ul style="list-style-type: none"> • It is suspected that the wall follow sensor, the cliff sensors or the carpet detection sensor may be dirty, clean the same with a soft and dry cloth.
Dock LED status indicator in flashing red	<ul style="list-style-type: none"> • Dust bag is not in place, install the dust bag in place; • The clean water tank is empty, or it is not in place, please handle accordingly; • The waste water tank is full, or it is not in place, please handle accordingly;
Bad dust collection effect or abnormal sound during dust collection	<ul style="list-style-type: none"> • The filter, the air duck, the dust collection opening, the dust collection air inlet, the dust bin, or the dust bag is blocking, please clean the same.
Poor self-cleaning effect of mopping cloth	<ul style="list-style-type: none"> • The mopping cloth is not flat, reattach the mopping cloth.
Automatic dust collection failure	<ul style="list-style-type: none"> • The dust bag is not in place, load a dust bag; • The cover of the dust collection tank is not properly closed, close the cover properly; • If the robot is in the "mopping only" mode, the dust collection function will not be enabled when it return to the dock.
No mopping cloth cleaning	<ul style="list-style-type: none"> • If the robot is in the "vacuuming only" mode, it will not clean the mopping cloth automatically. • If the robot is not started from the dock, or if the dock is not marked in App Map, the robot will be unable to return to the dock to clean the mopping cloth; • The clean water tank is empty or it is not in place, the waste water tank is full or it is not in place.

Official website: www.lynkbey.com

Email: support@lynkbey.com

LYNKBEY M10UM EN V01