



BY **ACCUAIR**

INSTRUCTION MANUAL



TERMS & CONDITIONS:

AccuAir Control Systems, L.L.C. is hereby referred to as ACCUAIR. The Purchaser, end-user, or installer is hereby referred to collectively as CUSTOMER. By purchasing and installing the ACCUAIR products, systems, or components to which this Installation Manual relates, CUSTOMER is deemed to agree with and accept the terms and conditions below.

Limited Warranty

ACCUAIR will repair or replace any defective products or components for the life of the vehicle on which they were originally installed, provided that the products or components were installed exactly as instructed herein, not modified or altered, and operated as expressly intended by ACCUAIR. Upon the return of a failed component(s) at CUSTOMER's expense, ACCUAIR will determine the cause of failure. If it is due to improper installation or misuse of the system, as determined by ACCUAIR, a repair charge will be assessed, and the customer will be contacted before work is performed or replacement parts are shipped. If the failure is due to defectively manufactured parts, then ACCUAIR will either repair or replace the failed components, at their own discretion and in a timely manner. There are no other warranties, express or implied, except as contained in this paragraph.

Repairs and Returns

A Return Merchandise Authorization Number (RMA) is required for ALL shipments to ACCUAIR. This number should be written in large letters on the shipping box. Call ACCUAIR to receive an RMA number and send items to:

AccuAir Suspension
100 Sea Ray Drive
Merritt Island, FL 32953
ATTN / RMA #: _____

Legal Disclaimer (IMPORTANT – PLEASE READ CAREFULLY)

- ACCUAIR's products are intended and designed for off-road use. If a customer chooses to use ACCUAIR's products on a highway, CUSTOMER understands that they do so at their own risk.
- ACCUAIR's products must be installed by a qualified professional installation facility, as recommended by ACCUAIR.
- ACCUAIR's products may void or limit any manufacturer's warranty or service contract covering CUSTOMER's vehicle. ACCUAIR shall have no liability for any effect that installation of its products may have on such warranties or service contracts.
- ACCUAIR's products may drastically alter the performance characteristics of CUSTOMER's vehicle and may cause it to operate in a manner not intended by the vehicle's original manufacturer. System operation and installation is at the CUSTOMER's own risk.
- CUSTOMER is responsible for periodically inspecting any and all ACCUAIR products or components installed on CUSTOMER's vehicle, to ensure they remain safe and functional. ACCUAIR shall have no liability for any loss or injury caused by CUSTOMER's failure to inspect.
- ACCUAIR shall have no liability for damage to property or persons caused by its products, components, accessories, installation instructions, or otherwise. CUSTOMER alone assumes all such risks and liabilities.
- ACCUAIR accepts no responsibility for systems, products or components provided by other manufacturers for use with or around the ACCUAIR system. For components other than ACCUAIR's, follow the manufacturer's instructions for installation and operation.
- ACCUAIR's liability, if any, shall be limited to the replacement cost of the purchased product or component.
- Any and all disputes between ACCUAIR and CUSTOMER relating to the purchase or installation of an ACCUAIR product or component must be resolved through final and binding arbitration, applying the laws of the State of California, and conducted pursuant to the California Arbitration Act (California Civil Code sections 1280, et seq.). Arbitration shall take place in San Luis Obispo, California, and CUSTOMER consents to personal jurisdiction in California.

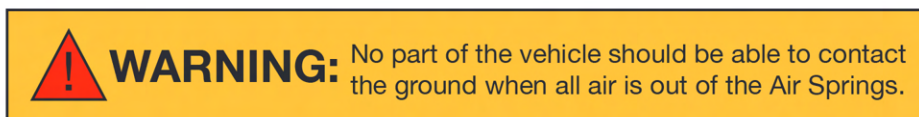



INSTALLATION AND OPERATING INSTRUCTIONS

Congratulations on purchasing your AccuAir ENDO system. Carefully follow these instructions to ensure years of safe and reliable operation of your ENDO-T or ENDO-VT system.

TABLE OF CONTENTS:

FOR ENDO-T AND ENDO-VT	1
Air Pressure Limits	1
Physical Specifications	1
Torque Specifications	1
Electrical Specifications (ENDO-VT only)	1
Vehicle Mounting	2
Using the QR Mount	3
Installing NPT Plugs	4
Removing the End Caps	5
FOR ENDO-VT ONLY	6
ENDO-VT PTC Fittings	6
ENDO-VT PTC Service Instructions	7
ENDO-VT Electrical and Pneumatic Connections	8
ENDO-VT Flow Adjustment	9
VT45 - Left-Right Orientation (Standard)	11
VT45 - Front-Rear Orientation	13
Dual VT23 - Left-Right Orientation	15
Dual VT23 - Front-Rear Orientation	18
Single VT23 - Front ONLY Orientation	19
Single VT23 - Rear ONLY Orientation	20

FOR ENDO-T AND ENDO-VT

AIR PRESSURE LIMITS

Both ENDO-T and ENDO-VT are DOT rated for **200 psi maximum pressure (13.6 bar)**. Failure to observe maximum rated pressure could result in tank rupture and consequent property damage or personal injury.

Both the ENDO-T and ENDO-VT include a Pressure Relief Valve (see Figure 1) set for 400 psi (27.2 bar). This opening pressure exceeds any normal operating pressure and is in place to protect against extreme conditions.

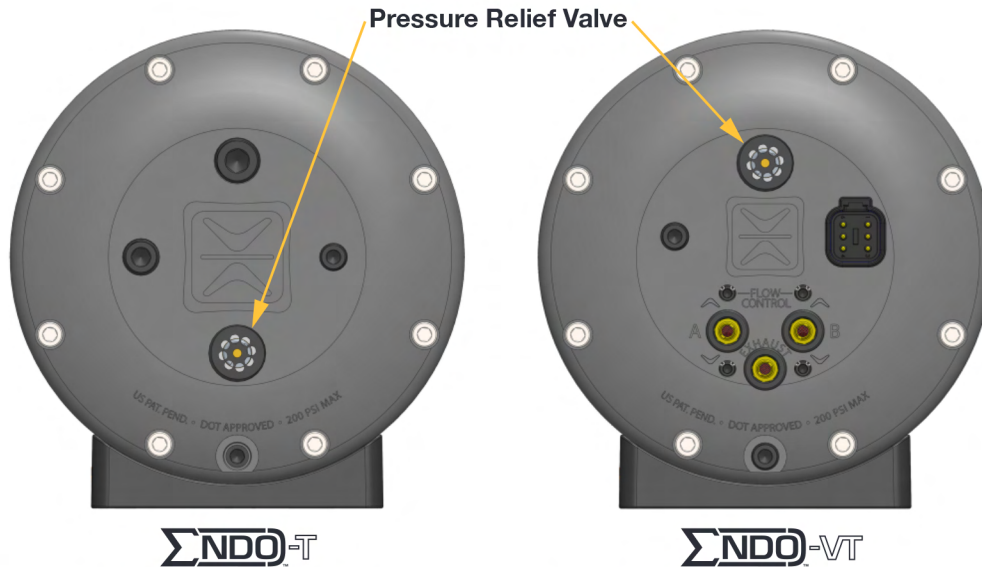

Figure 1: Standard Pressure Relief Valve installation in ENDO-T and ENDO-VT systems.

Physical Specifications

Product	Diameter	Length	Air Spring Ports
ENDO-T3	6.62in (168mm)	18.3in (465mm)	N/A*
ENDO-T5	6.62in (168mm)	29.3in (745mm)	N/A*
ENDO-VT23	6.62in (168mm)	18.4in (468mm)	2
ENDO-VT45	6.62in (168mm)	29.5in (750mm)	4

*Requires external manifold and valves like the AccuAir VU2 or VU4.

Table 1: ENDO-T and ENDO-VT physical specifications

Torque Specifications

Fastener	Torque
Quick Release (QR) Pins	40 in-lbs (3.3 ft-lbs, 4.5 N-m)
Quick Release Base Mounting Bolts	120 in-lbs (10.0 ft-lbs, 13.5 N-m)
Quick Release Set Screw	40 in-lbs (3.3 ft-lbs, 4.5 N-m)
ENDO Cap Bolts	200 in-lbs (16.7 ft-lbs, 22.6 N-m)

Table 2: ENDO-T and ENDO-VT Fastener torque specifications

Electrical Specifications (ENDO-VT only)

Component	Voltage Requirement	Amperage Requirement	Ingress Protection
Solenoid Valve	6.62in (168mm)	1.1A (each; 4x for VT23, 8x for VT45)	IP67

Table 3: Electrical specifications for the ENDO-VT product line

VEHICLE MOUNTING

- Your ENDO Tank system has been designed to use AccuAir's unique Quick Release (QR) mounting system. The QR mounts are installed on the tank at the factory and will need to be removed prior to installation.
- The mounting template, included in the shipping carton of your ENDO system, has complete details on mounting your tank to your vehicle. Accurate location of the QR mounts is critical for a successful installation. **Read all steps** before starting your installation.
- The QR mounting system has been designed to attach the ENDO Tank securely to a flat surface. Minor variations can be handled with shims of appropriate thickness. If your intended mounting location is significantly uneven, AccuAir strongly recommends mounting the QR bases to a suitable plate that is then installed on the vehicle.
- AccuAir recommends mounting the QR mounting bases with the included 5/16"-18 screws or 1/4"-20 self-tapping screws at **120 in-lbs** (10 ft-lbs, 13.6 N-m) torque. Use care when tightening these fasteners as over-torquing can cause the QR bases to distort.

Pro-Tip: On first installation of the tank, tighten the bolts between the QR mounting bases and the vehicle until they are just snug. Install the tank into its final position and let the mounts adapt, then remove the tank again to torque the bolts.

CAUTION: The QR mounting "pins" have been pre-installed in the tank body with a thread locker. There should be no need to tighten these fasteners. If for some reason they need to be removed, then upon re-installation apply a thread locker (Loctite 262 or equivalent) to the threads and torque to **40 in-lbs** (3.3 ft-lbs, 4.5 N-m). Significantly over-torquing these fasteners may cause damage to the tank or the fasteners.

NOTE: AccuAir EXO clamps may also be used with the ENDO Tank if desired. If using EXO, remove the QR mounting pins.

USING THE QR MOUNT

1. Install the QR Mounts to your vehicle using the hardware and specifications included on your mounting template.
2. Align the QR mounting pins with the holes in QR mounts and insert them until the tank body is in full contact with the QR mounts.
3. Rotate the tank body on its long axis such that the QR mounting pins move away from the set screw. Continue rotation until the pins snap into place.
4. Install the set screw with the included Loctite 262 and tighten until it is flush with the front surface of the mounting base and torque to **40 in-lbs** (3.3 ft-lbs, 4.5 N-m).

NOTE: The threaded insert for the mounting base set screw has been designed with an anti-vibration feature similar to a nylon insert lock nut. There will be resistance to rotation prior to contact between the set screw and the QR mounting pins.

Pro-Tip: If the QR mounts seem tight, and won't "click" into final position, the set screws may be used to push the mounting pins into position.

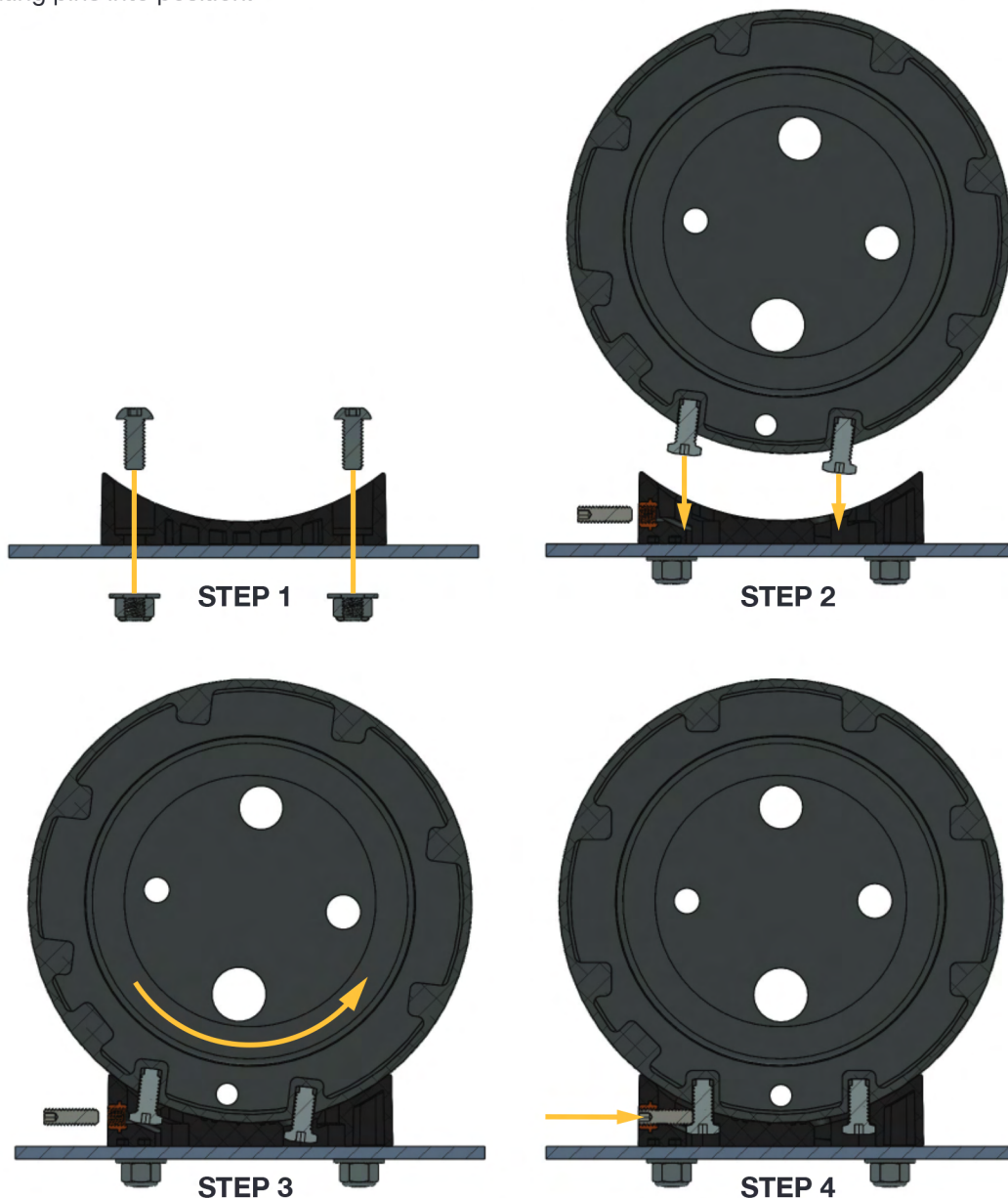

Figure 2: Four step QR operation procedure

INSTALLING NPT PLUGS

- Identify the NPT plugs necessary for your application from the selection provided with your ENDO-T or ENDO-VT product.
- Apply the thread sealant (Loctite 565 or equivalent) provided with your ENDO product to the NPT fitting prior to installation.
- Thread the plug into the hole until it is “finger tight” then tighten between 0.5 and 1.5 full turns.
- Wait until the 565 is cured before pressurizing your system.

CAUTION: If using the AccuAir supplied NPT plugs, these should assemble flush with the tank surface. Other plugs will install differently. Do not over tighten as this can cause damage to the tank or NPT fitting.

CAUTION: At this point, patience should be exercised as the liquid thread sealant needs time to cure. Applying air pressure to the tank may disturb the curing process resulting in leaks. Read the directions on the thread sealant package and wait the recommended cure time.

Pro-Tip: Remove excess Loctite 565 with a Q-tip dipped in brake-clean or other solvent.

REMOVING THE END CAPS

Your ENDO tank has been fully assembled and tested by AccuAir. In many circumstances, it will never be necessary to remove the end caps for the life of the product. Some potential reasons for removing the end caps may include:

- If you flip your ENDO tank upside down in order to top mount it, then you will need to remove and rotate the end caps in order to keep the drain plugs pointed toward the bottom of the tank.
- If you choose to custom finish your ENDO tank, you may wish to disassemble it beforehand.
- Removal for cleaning the inlet filters or the inside of the ENDO tank.

WARNING: Fasteners and O-rings are not reusable. Purchase an ENDO Tank Rebuild Kit (Part No. AA-ENDO-TANK-SVC) prior to disassembly. Full instructions for cap removal and drawings for optional cap removal tools are included with the Tank Rebuild Kit. The processes described there will minimize the chance for damage to structural elements and surface finishes.

WARNING: Do not insert screwdrivers or any other prying tool into the gap between the tank body and end cap. Damage to both parts will result and it will fail to separate the cap from the body.

REMOVAL STEPS:

1. Remove your ENDO tank from the vehicle and place it on a work bench.
2. Loosen the end cap bolts on only one end cap by only **3 full turns each**.
3. Lightly pressurize your ENDO tank using shop air until the cap seal disengages from the center body of the ENDO tank.
4. Let the air pressure escape fully.
5. Remove the end cap bolts entirely.
6. Remove the first cap.
7. Remove the bolts entirely from the second end cap.
8. Use a long stick to gently tap the end cap from the center body, (use caution not to damage any of the wires or components on the inside of a VT end cap).

ASSEMBLY STEPS:

1. Remove the contents of your ENDO Tank Rebuild Kit (Part No. AA-ENDO-TANK-SVC).
2. Add an O-ring lubricant like Vaseline to the main O-ring that seals the end cap to the center body. Install the O-ring onto the end cap.
3. Use the two bolts on each end cap to properly align the end cap to the center body.
4. Lightly tap the end cap from side to side until it is fully seated in the center body.
5. Make sure that all of your new bolts included in the ENDO Tank Rebuild Kit have the yellow O-rings installed under each head.
6. Install all of the bolts hand tight.
7. Successively torque all of the end cap bolts in a star pattern up to **200 in-lbs (16.7 ft-lbs, 22.6 N-m)**.

WARNING: Failure to properly torque your end cap bolts may result in tank failure and/or personal injury.

FOR ENDO-VT ONLY

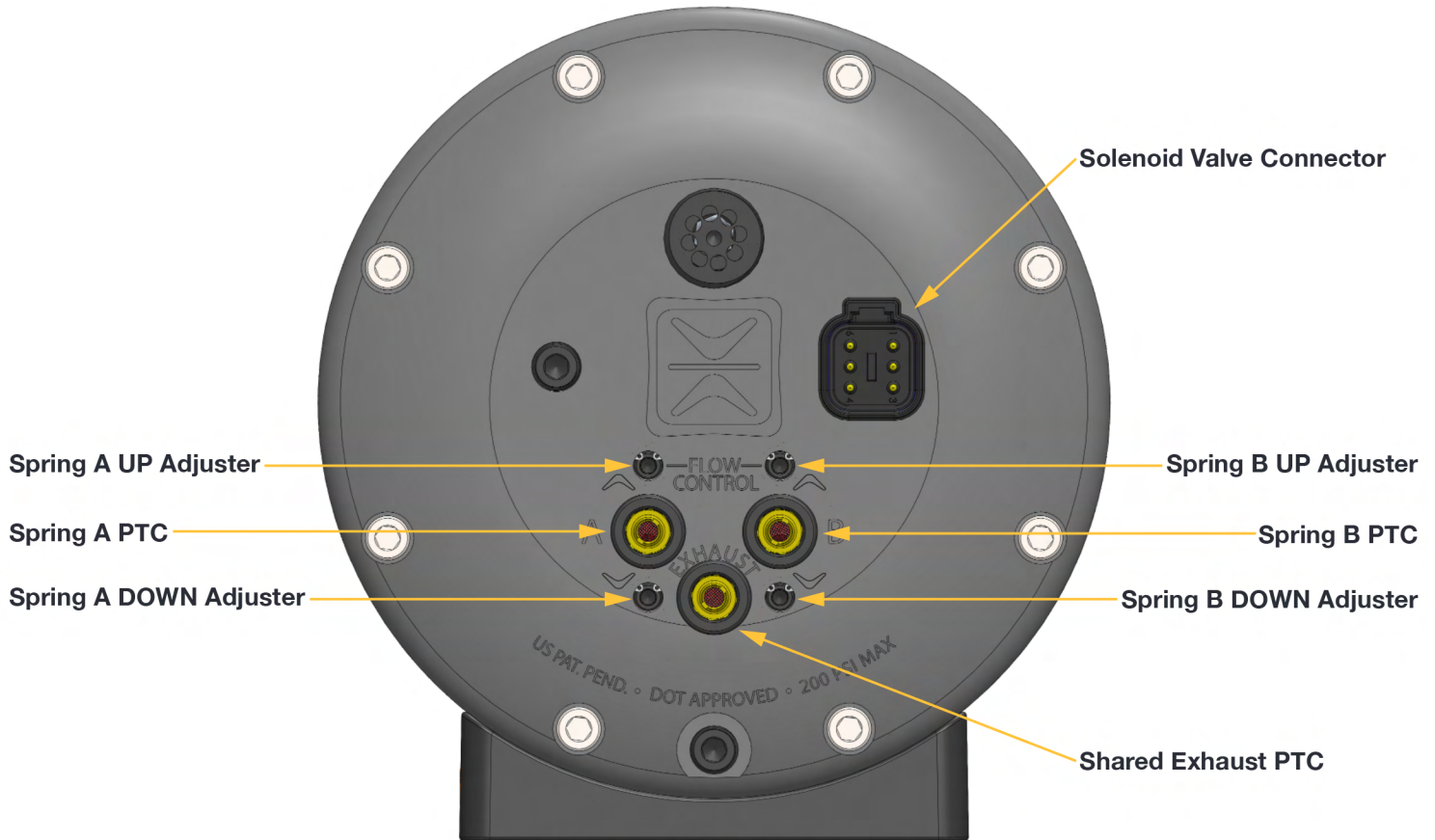

Figure 3: ENDO-VT Cap layout

ENDO-VT PTC FITTINGS

- Basic operation

- Air line installation – Cut the end of the air line as square as possible with a sharp blade or air line cutting tool. Make sure the cut end is free from burrs. Insert the end of the air line into the PTC fitting until it “bottoms out.” Pull firmly to test the connection. If the air line pulls out, re-insert and then pull the PTC collet outward from the face of the ENDO-VT cap. Pull firmly on the air line to test the connection.

- Air line removal – Press the PTC collet back toward the face of the ENDO-VT cap and hold it there while pulling firmly on the air line.

Pro-Tip: Use a 3/8" open-end wrench to hold the collet back while you pull to remove the air line.

- Acceptable size and types of air line:

- Plastic - 3/8" O.D. US DOT approved plastic air brake tubing
- Aluminum - 3/8" O.D., 1/4" I.D. tubing

WARNING: Stainless steel tubing will not be retained by the PTC fitting and will disconnect under pressure. **Do not use stainless tubing with the ENDO-VT.**

ENDO-VT PTC SERVICE INSTRUCTIONS

Your ENDO-VT tank has been fully assembled and tested by AccuAir. In many circumstances, it will never be necessary to service your Push To Connect fitting components. Some potential reasons for servicing your PTC fittings may include:

- A leaky fitting as the result of a damaged O-ring. The O-ring can get damaged by a burr on either soft or hard line. In this case you may choose NOT to remove the Filter Screen and Tube Stem if it is not clogged.
- A clogged filter screen as the result of too much debris present in your air springs or plumbing. In this case, you may choose to re-use the original O-ring if it is not leaking.

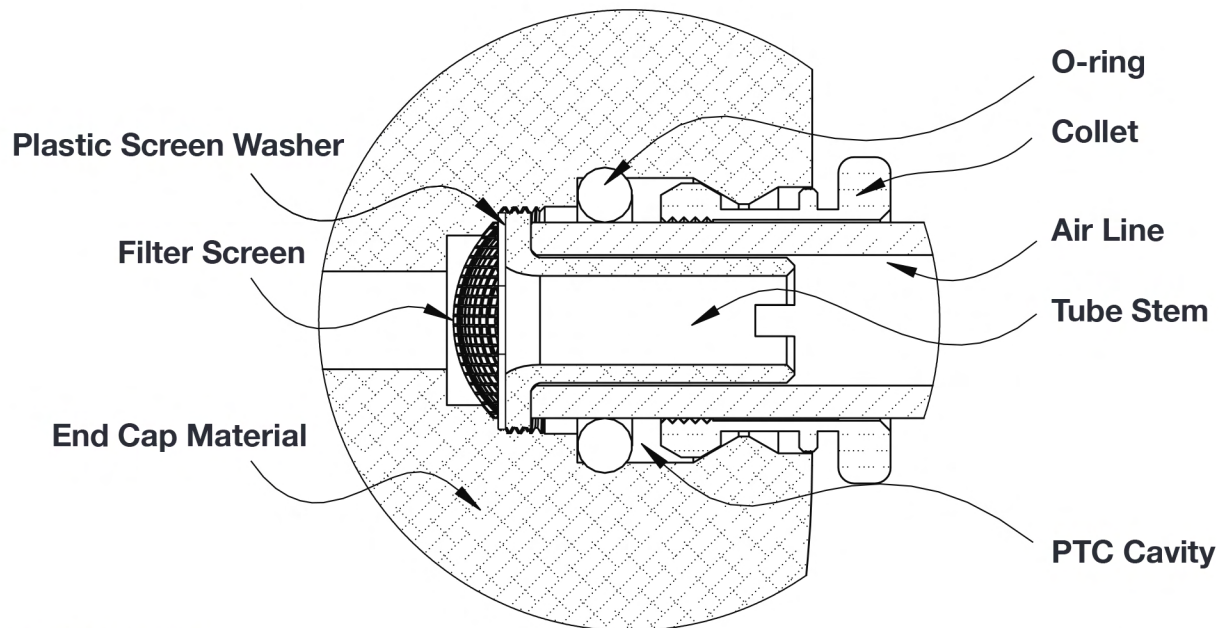

REMOVAL STEPS:

1. Remove the air line from the PTC fitting (Push the Collet in with a 3/8" open end wrench and pull the air line out).
2. Remove the PTC Collet from the PTC Cavity by inserting a towel covered flat head screw driver between the cap and the Collet and gently prying from side to side.
3. Use a flat head screwdriver to loosen the gold Tube Stem (CCW to remove).
4. Pull on the Tube Stem to bring the O-ring to the top of the PTC Cavity and hook it with a pick to remove it from the PTC Cavity.
5. Remove the gold Tube Stem from the PTC Cavity.
6. Use a pick tool to hook and remove the plastic Screen Washer from the PTC Cavity.
7. Use a pick tool to hook and remove the PTC Filter Screen.

ASSEMBLY STEPS:

1. Remove the contents of your ENDO PTC Service Kit (Part No. AA-ENDO-PTC-SVC).
2. Gently install the new Filter Screen with a soft faced tool with the DOME oriented as shown above.
3. Install the plastic Screen Washer on top of the Filter Screen.
4. Use a flat head screwdriver to install the gold Tube Stem hand tight (CW to install).
(DO NOT CROSS THREAD OR OVER TORQUE THE TUBE STEM).
5. Install the O-ring into the PTC Cavity and make sure that it lays flat.
6. Push the Collet back into the PTC Cavity.

ENDO-VT ELECTRICAL AND PNEUMATIC CONNECTIONS

Compressors: Air compressors can be attached to any of the available NPT fittings on the side or the end caps of the tank. The side ¼” NPT ports with 90 degree elbow fittings installed are the best location to connect your compressor(s) if using ENDO Brackets.

Air Springs: Each ENDO-VT end cap has PTC fittings for two air springs, marked “A” and “B” (see Figure 3). Each will be connected via plastic or aluminum tubing to the air springs. The following pages detail the electrical and air line connections for the most common configurations of the ENDO-VT45 and ENDO-VT23 systems with the AccuAir e-Level. If you choose to use another control solution, refer to the table below for the ENDO-VT electrical connector pin-out.

Exhaust: Both air springs share a single exhaust port in the ENDO-VT end cap. This central PTC fitting, marked “EXHAUST,” may be left open, or vented outside the vehicle and/or equipped with a muffler like AccuAir Part No. AA-38-MUFF-2.

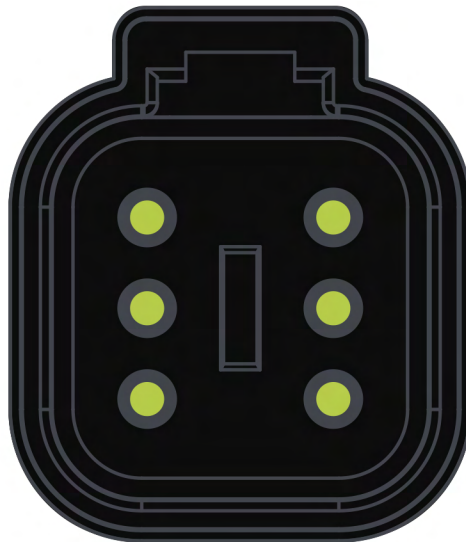

Figure 4: Pin layout for ENDO-VT solenoid valve electrical connector.

VT Connector Pin	Solenoid Valve
1	Inlet B
2	Exhaust B
3	Exhaust A
4	Unused
5	Ground
6	Inlet A

Table 4: Pin-out of the ENDO-VT solenoid valve electrical connector. “A” and “B” refer to the air springs connected to the A and B push-to-connect air line ports on the VT end-cap (see Figure 3).

ENDO-VT FLOW ADJUSTMENT

The AccuAir ENDO-VT end caps have flow adjustment screws to control the rate of airflow between the air springs and the solenoid valves. These allow speed adjustment of each corner of the car independently, both up and down, so you can adjust the front and rear to lift and lower at the same speed.

Each air spring port on an ENDO-VT tank cap has adjuster screws for inlet and exhaust above and below (respectively) the push-to-connect fitting (see Figure 3). Each screw has 10 turns of adjustment from fully open (top) to fully closed (bottom). Adjustment is nearly linear for most of the range. For example, starting 2 turns from the bottom and backing out the adjuster 2 turns (4 turns total) will almost double the flow.

The ENDO-VT has been shipped from the factory with all of the flow control screws set to maximum speed (top). You can choose to slow down the speed of a desired air spring in a desired direction by turning the screw clockwise toward the bottom. Match the number of turns for the paired air spring and direction (i.e., 2 turns in for the left rear “UP” should be matched at 2 turns in for the right rear “UP”).

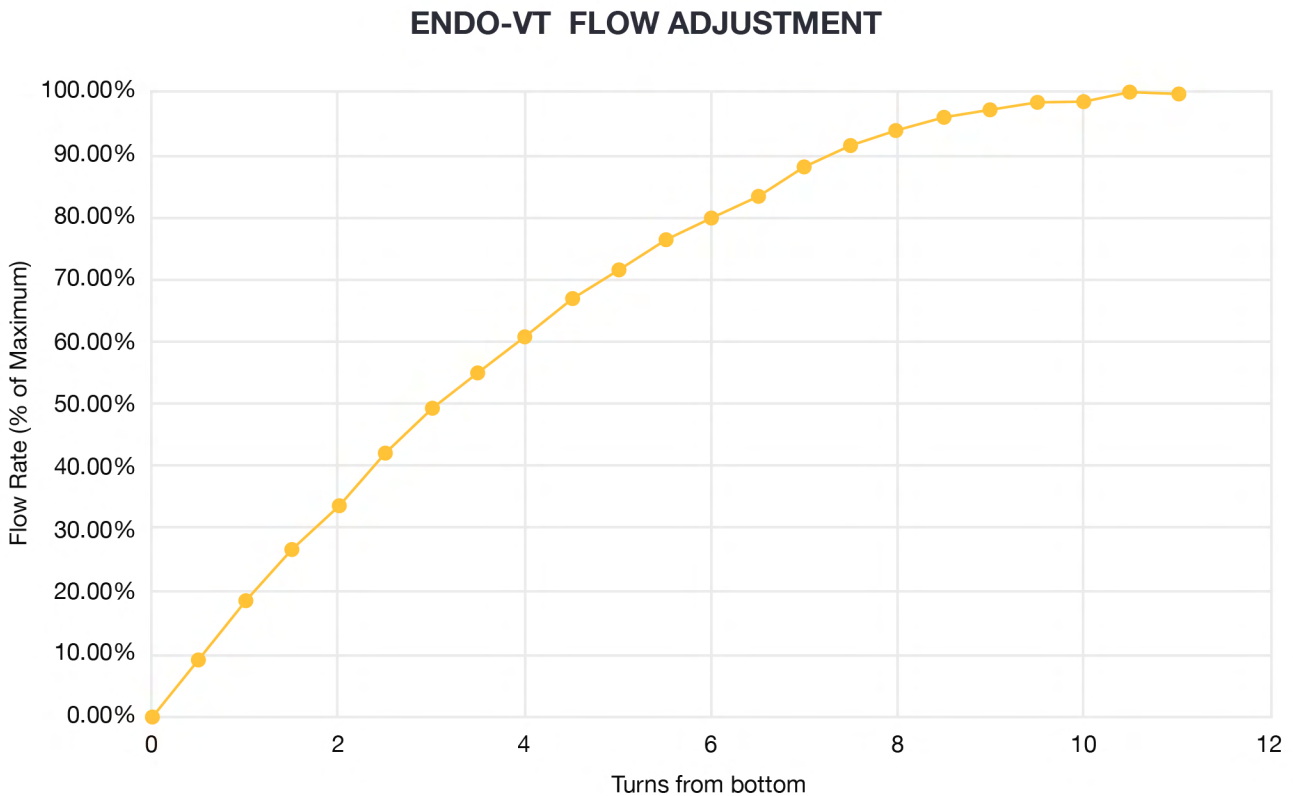

Figure 5: ENDO-VT flow adjustment behavior

Pro-Tip: The light end of the vehicle (usually the rear) will naturally lift faster and lower slower than the heavy end (usually the front). Use this multi-step process to make the front and rear of your vehicle adjust level at all times.

1. Start with all of the flow control screws set to maximum speed (top).
2. Starting with the vehicle at lowest height, find the fast LIFTING end of your vehicle by pressing all four UP buttons at the same time to LIFT the vehicle. The fast end will reach the top of the travel first.
3. Slow the UP flow controls for the fast end of the vehicle by turning the flow control screws clockwise for the right and left equally (start with one turn and go to half turns as you get closer to matching the speed).
4. Repeat steps 2-3 until the front and rear of your vehicle lift at the exact same speed.
5. Starting with the vehicle at highest height, find the fast LOWERING end of your vehicle by pressing all four DOWN buttons at the same time to LOWER the vehicle. The fast end will reach the bottom of the travel first.
6. Slow the DOWN flow controls for the fast end of the vehicle by turning the flow control screws clockwise for the right and left equally (start with one turn and go to half turns as you get closer to matching the speed).
7. Repeat steps 5-6 until the front and rear of your vehicle lift at the exact same speed.
8. **If you are using an AccuAir e-Level system, make sure to recalibrate the e-Level system after you have finished adjusting your flow control screws.**

CAUTION: Do not remove the adjuster screws with the system under pressure. Removing an adjuster screw will release the air from the associated air spring. The screws are retained by a small circlip in order to prevent accidental removal.

CAUTION: Fully tightening an adjuster screw will disable that functionality for that air spring. For example, fully tightening the UP adjuster on “Spring A” will prevent any additional air from getting to that spring no matter the state of the solenoid valve.

VT45 - LEFT - RIGHT ORIENTATION (STANDARD)

VT45 - LEFT - RIGHT ORIENTATION (SEE FIGURE 6)					
VT HARNESS	VT Connector Pin	Solenoid Valve	Air Spring	VT Harness Wire Color	e-Level Harness Wire Color
VT45 LEFT	1	Inlet B	Left Rear (3)	White/Orange	White/Orange
	2	Exhaust B	Left Rear (3)	White/Green	White/Green
	3	Exhaust A	Left Front (1)	White/Blue	White/Blue
	4	UNUSED			
	5	Ground	Shared	Black	GROUND
	6	Inlet A	Left Front (1)	White	White
VT45 RIGHT	1	Inlet B	Right Front (2)	White/Purple	White/Purple
	2	Exhaust B	Right Front (2)	White/Brown	White/Brown
	3	Exhaust A	Right Rear (4)	White/Gray	White/Gray
	4	UNUSED			
	5	Ground	Shared	Black	GROUND
	6	Inlet A	Right Rear (4)	White/Black	White/Black

Table 5: ENDO-VT45 solenoid valve wire mapping between ENDO-VT45 wiring harness and the main e-Level valve wiring harness assuming a left-right orientation (see Figure 6).

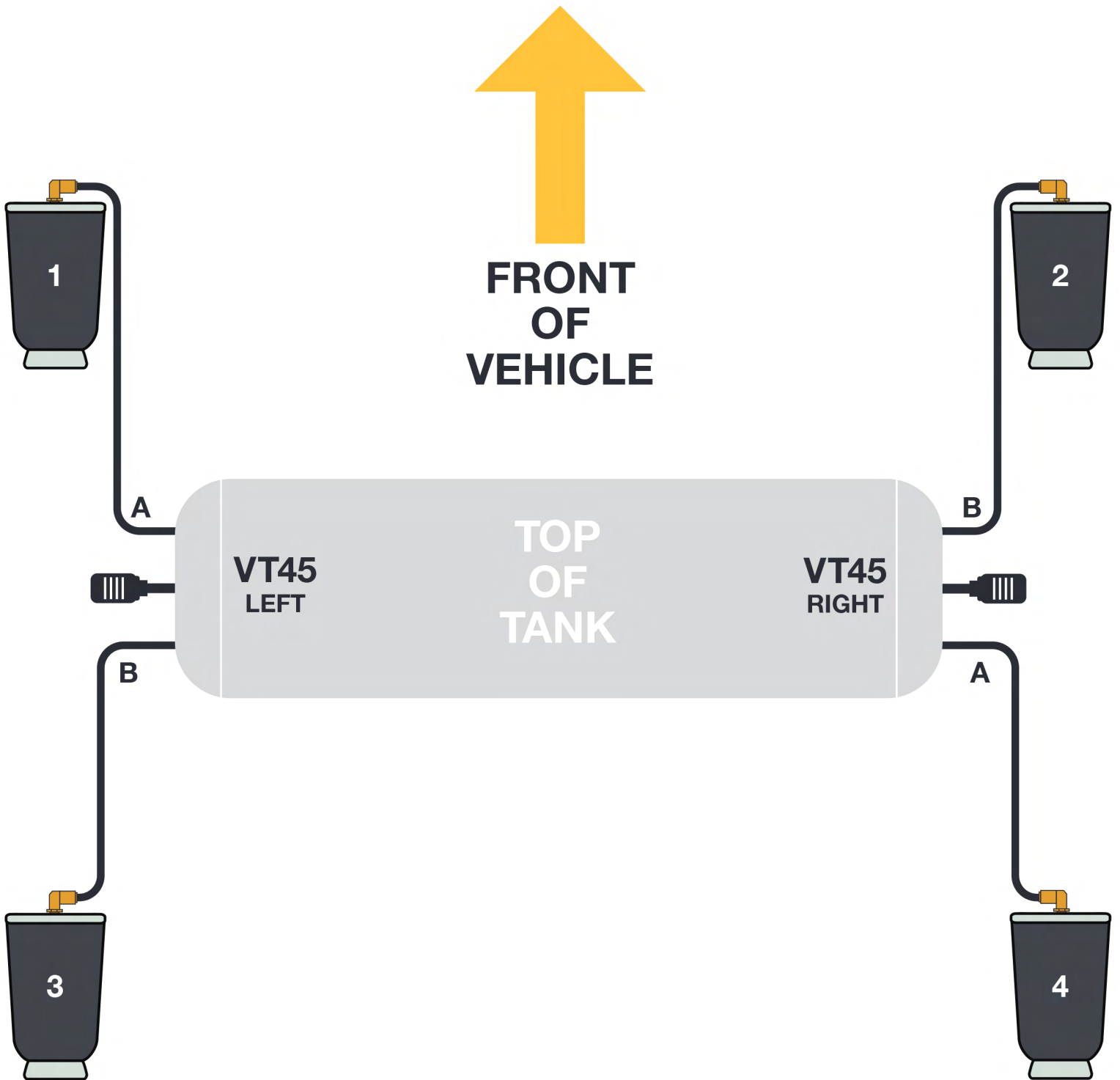

Figure 6: Pneumatic schematic for ENDO-VT45 with a left-right orientation

VT45 - FRONT - REAR ORIENTATION

VT45 - FRONT- REAR ORIENTATION (SEE FIGURE 7)					
VT HARNESS	VT Connector Pin	Solenoid Valve	Air Spring	VT Harness Wire Color	e-Level Harness Wire Color
VT45 FRONT	1	Inlet B	Left Front (1)	White/Orange	White
	2	Exhaust B	Left Front (1)	White/Green	White/Blue
	3	Exhaust A	Right Front (2)	White/Blue	White/Brown
	4	UNUSED			
	5	Ground	Shared	Black	GROUND
	6	Inlet A	Right Front (2)	White	White/Purple
VT45 REAR	1	Inlet B	Right Rear (4)	White/Purple	White/Black
	2	Exhaust B	Right Rear (4)	White/Brown	White/Gray
	3	Exhaust A	Left Rear (3)	White/Gray	White/Green
	4	UNUSED			
	5	Ground	Shared	Black	GROUND
	6	Inlet A	Left Rear (3)	White/Black	White/Orange

Table 6: ENDO-VT45 solenoid valve wire mapping between ENDO-VT45 wiring harness and the main e-Level valve wiring harness assuming a front-rear orientation (see Figure 7).

NOTE: There is a mismatch between VT45 and e-Level wire colors. This is expected. Follow this table carefully when wiring your vehicle.

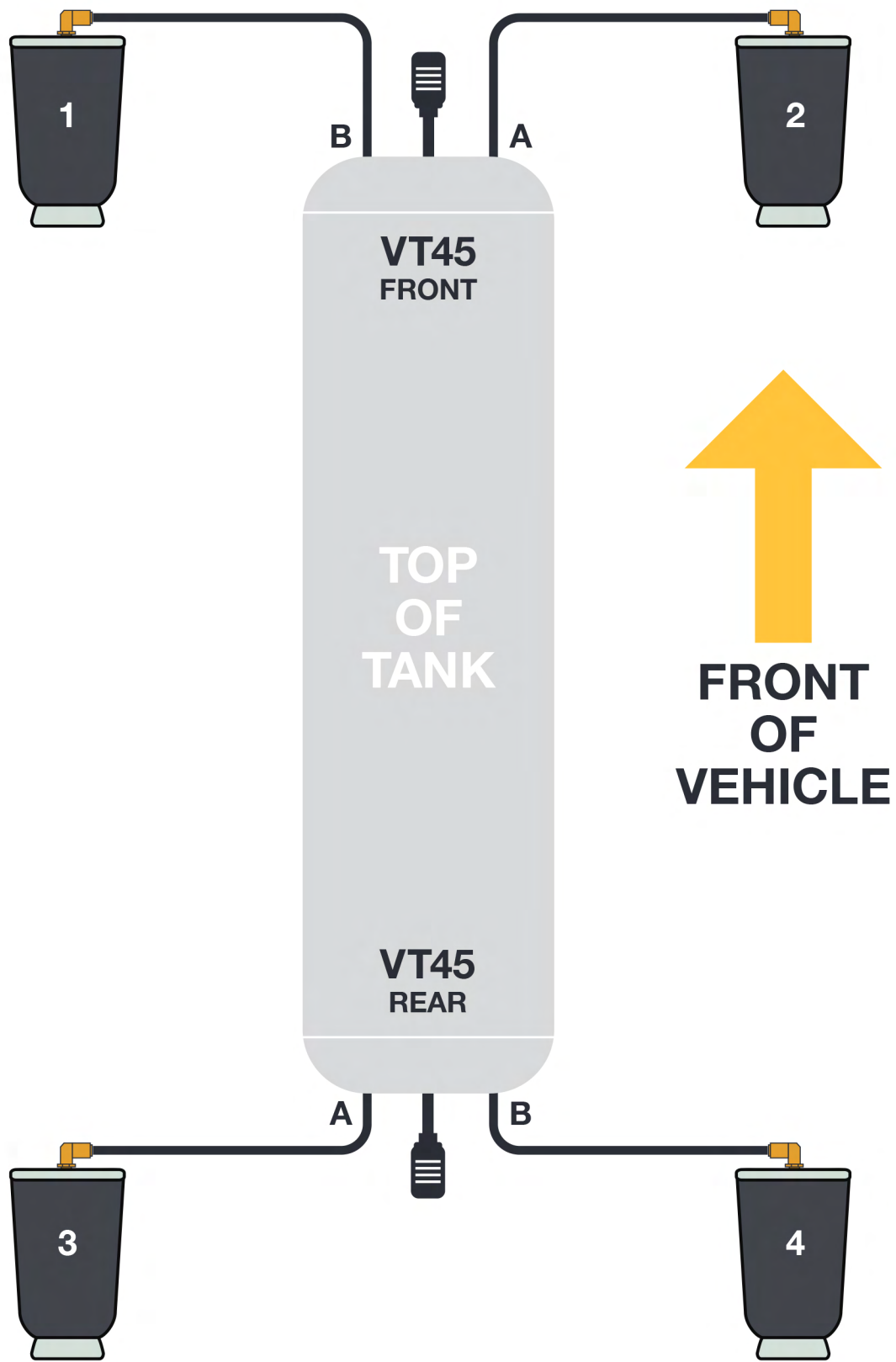

Figure 7: Pneumatic schematic for ENDO-VT45 with a front-rear orientation

DUAL VT23 - LEFT - RIGHT ORIENTATION

DUAL VT23 - LEFT- RIGHT ORIENTATION (SEE FIGURE 8)					
VT HARNESS	VT Connector Pin	Solenoid Valve	Air Spring	VT Harness Wire Color	e-Level Harness Wire Color
VT23 LEFT	1	Inlet B	Left Rear (3)	Brown	White/Orange
	2	Exhaust B	Left Rear (3)	Green	White/Green
	3	Exhaust A	Left Front (1)	Pink	White/Blue
	4	UNUSED		UNUSED	
	5	Ground	Shared	Black	GROUND
	6	Inlet A	Left Front (1)	Gray	White
VT23 RIGHT	1	Inlet B	Right Front (2)	Brown	White/Purple
	2	Exhaust B	Right Front (2)	Green	White/Brown
	3	Exhaust A	Right Rear (4)	Pink	White/Gray
	4	UNUSED		UNUSED	
	5	Ground	Shared	Black	GROUND
	6	Inlet A	Right Rear (4)	Gray	White/Black

Table 7: ENDO-VT solenoid valve wire mapping between dual ENDO-VT23 wiring harnesses and the main e-Level valve wiring harness assuming the left VT23 controls the left side of the vehicle and the right VT23 controls the right side. **NOTE:** No attempt has been made to match the solid colors of the VT23 harness with the stripes of the e-Level harness. Follow this table carefully when wiring your vehicle.

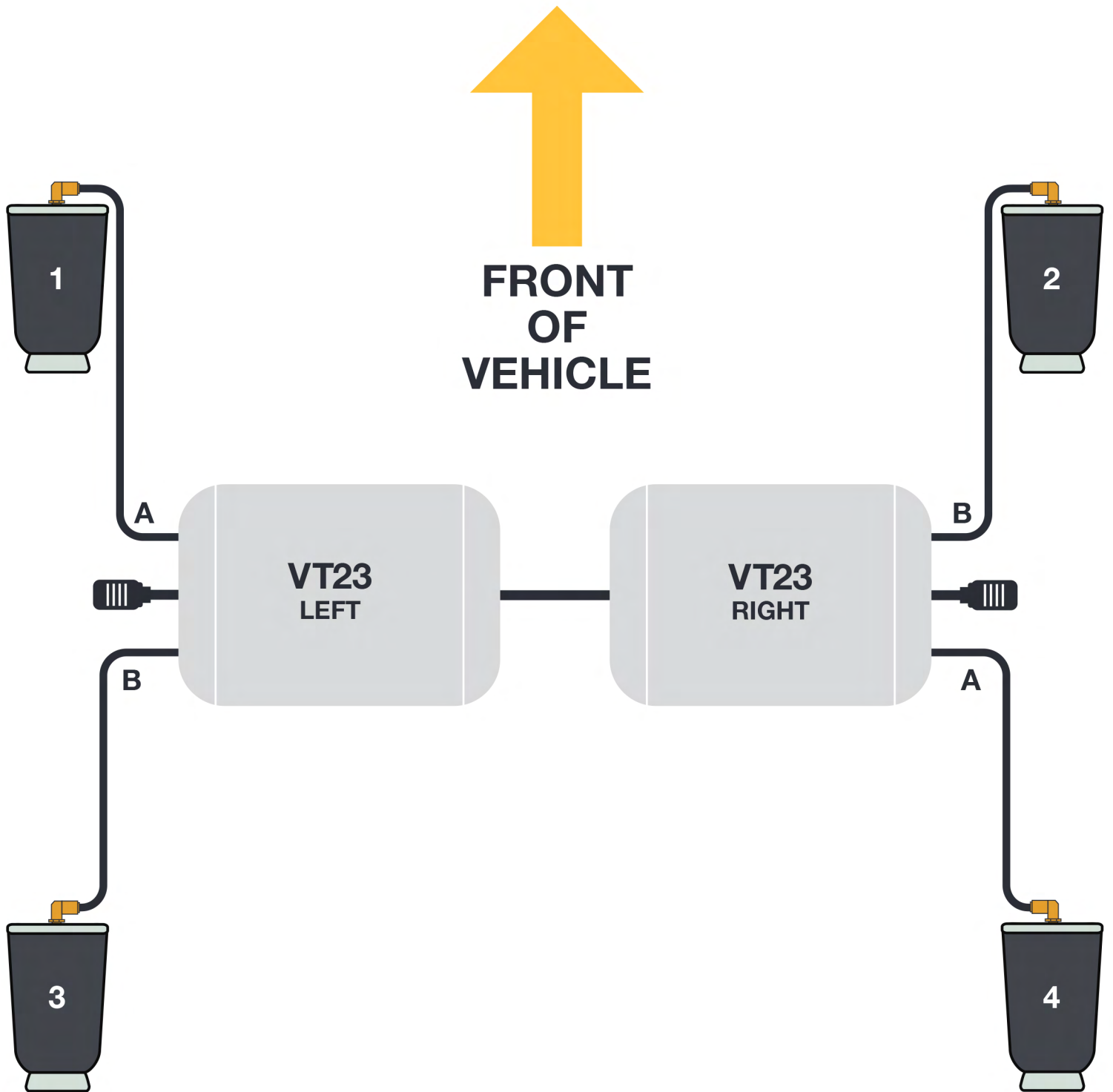

Figure 8: Pneumatic schematic for dual ENDO-VT23 with left-right orientation

DUAL VT23 - FRONT - REAR ORIENTATION

DUAL VT23 - FRONT- REAR ORIENTATION (SEE FIGURE 9)					
VT HARNESS	VT Connector Pin	Solenoid Valve	Air Spring	VT Harness Wire Color	e-Level Harness Wire Color
VT23 FRONT	1	Inlet B	Left Front (1)	Brown	White
	2	Exhaust B	Left Front (1)	Green	White/Blue
	3	Exhaust A	Right Front (2)	Pink	White/Brown
	4	UNUSED		UNUSED	
	5	Ground	Shared	Black	GROUND
	6	Inlet A	Right Front (2)	Gray	White/Purple
VT23 REAR	1	Inlet B	Right Rear (4)	Brown	White/Black
	2	Exhaust B	Right Rear (4)	Green	White/Gray
	3	Exhaust A	Left Rear (3)	Pink	White/Green
	4	UNUSED		UNUSED	
	5	Ground	Shared	Black	GROUND
	6	Inlet A	Left Rear (3)	Gray	White/Orange

Table 8: ENDO-VT solenoid valve wire mapping between dual ENDO-VT23 wiring harnesses and the main e-Level valve wiring harness assuming the front VT23 controls the front of the vehicle and the rear VT23 controls the rear **NOTE:** No attempt has been made to match the solid colors of the VT23 harness with the stripes of the e-Level harness. Follow this table carefully when wiring your vehicle.

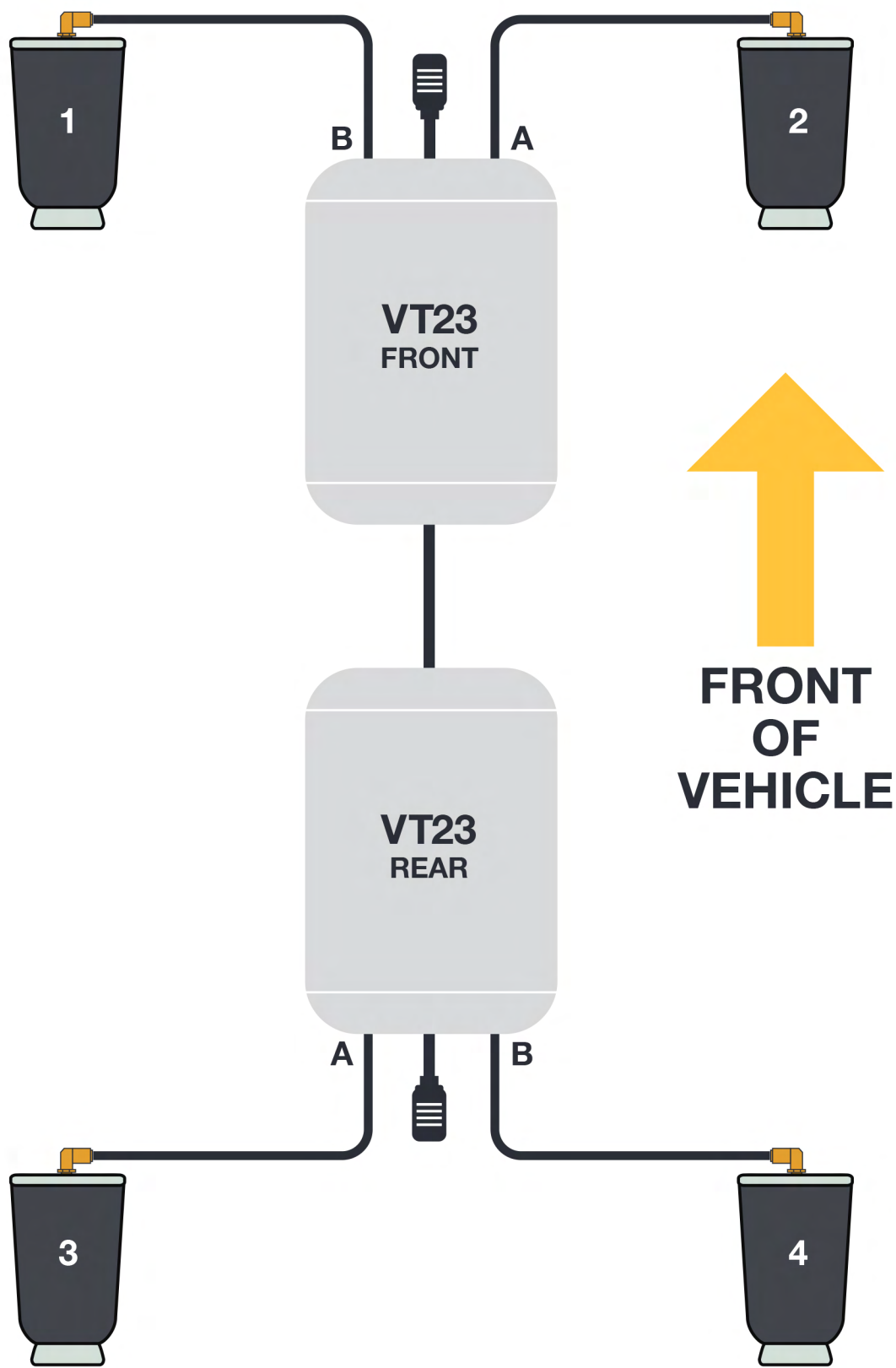

Figure 9: Pneumatic schematic for dual ENDO-VT23 with front-rear orientation

SINGLE VT23 - FRONT ONLY ORIENTATION

SINGLE VT23 - FRONT- WHEEL INSTALLATION (SEE FIGURE 10)				
VT Connector Pin	Solenoid Valve	Air Spring	VT23 Harness Wire Color	e-Level Harness Wire Color
1	Inlet B	Left Front (1)	Brown	White/Orange
2	Exhaust B	Left Front (1)	Green	White/Green
3	Exhaust A	Right Front (2)	Pink	White/Gray
4	UNUSED	N/A	UNUSED	
5	Ground	Shared	Black	GROUND
6	Inlet A	Right Front (2)	Gray	White/Black

Table 9: ENDO-VT solenoid valve connector wiring for single ENDO-VT23 FRONT spring control configuration. **NOTE:** No attempt has been made to match the solid colors of VT23 harness with the e-Level harness stripes. Follow this table carefully when wiring your vehicle.

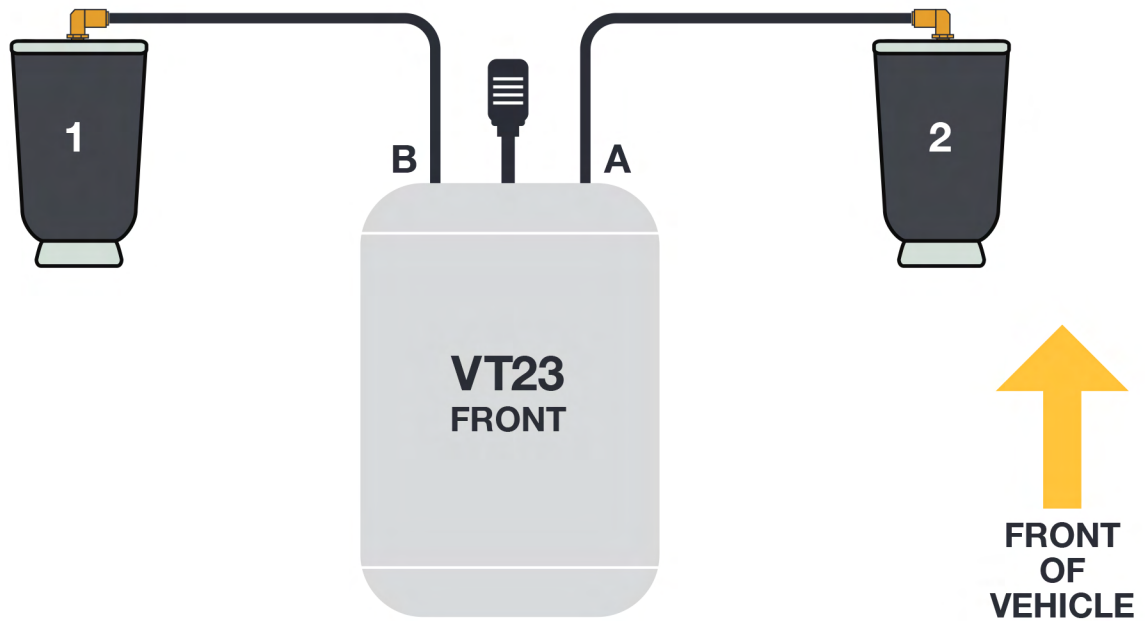

Figure 10: Pneumatic schematic for a single ENDO-VT23 controlling the front wheels only

SINGLE VT23 - REAR ONLY ORIENTATION

SINGLE VT23 - REAR- WHEEL INSTALLATION (SEE FIGURE 11)				
VT Connector Pin	Solenoid Valve	Air Spring	VT23 Harness Wire Color	e-Level Harness Wire Color
1	Inlet B	Right Rear (4)	Brown	White/Black
2	Exhaust B	Right Rear (4)	Green	White/Gray
3	Exhaust A	Left Rear (3)	Pink	White/Green
4	UNUSED	N/A	UNUSED	
5	Ground	Shared	Black	GROUND
6	Inlet A	Right Rear (3)	Gray	White/Orange

Table 10: ENDO-VT solenoid valve connector wiring for single ENDO-VT23 REAR spring control configuration. NOTE: No attempt has been made to match the solid colors of VT23 harness with the e-Level harness stripes. Follow this table carefully when wiring your vehicle.

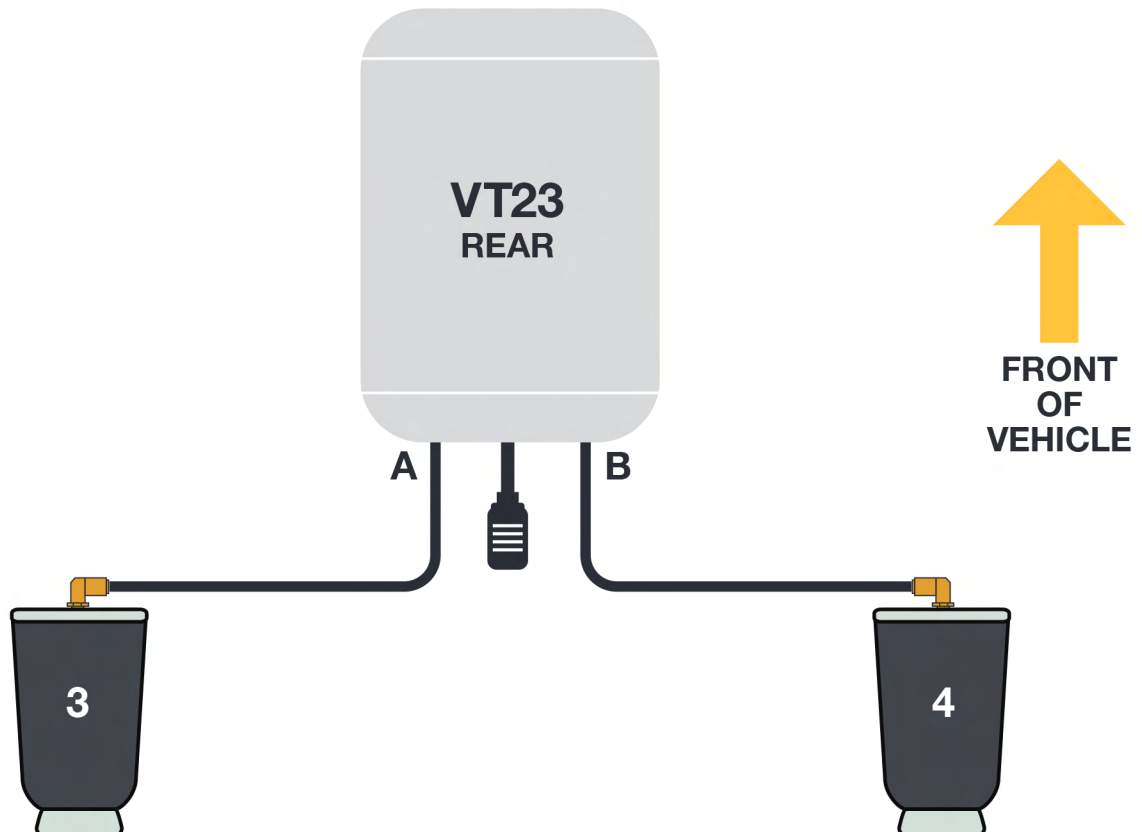

Figure 11: Pneumatic schematic for a single ENDO-VT23 controlling the rear wheels only



ACCUAIR

877.247.3696 WWW.ACCUAIR.COM
100 Sea Ray Drive, Merritt Island, FL 32953

