

Vinotemp®

A PROUD HERITAGE OF EXPERIENCE & QUALITY

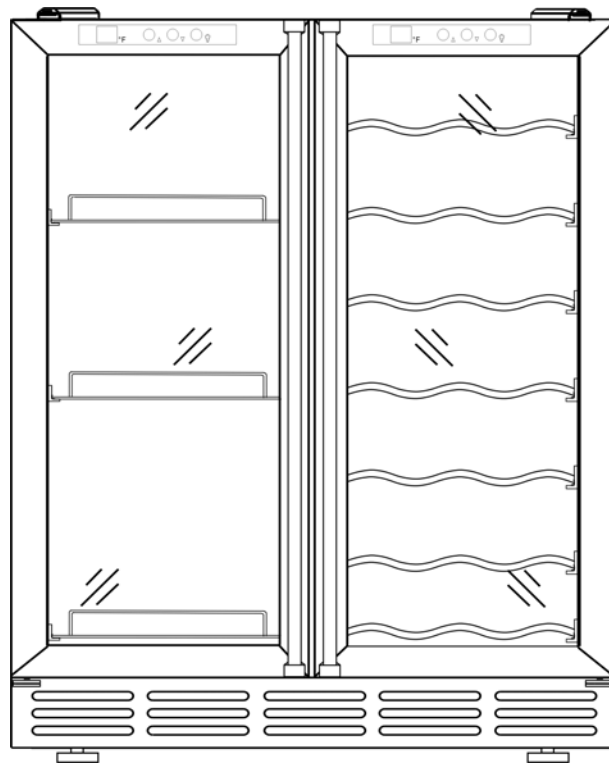

BEVERAGE/WINE COOLER

VT-38

OWNER'S MANUAL

YOUR BEVERAGE/WINE COOLER

This unit can be used for Storage and/or Service. The unit has a glass door and soft interior light that you can leave on to elegantly display your wines or beverages.

SERVING WINES

Storing wines at the proper temperature is important. To preserve them as long as possible wine should be stored at approximately 55°F. The chart below suggests the optimal serving temperature for the different styles of wine.

°C	°F	Wine Style
19	66	Armagnac, Brandy, Cognac
18	64.5	Full Bodied Red wines, Shiraz
17	62	Tawny Port
15	59	Medium Bodied Red Wines
14	57	Amontillado Sherry
13	55.5	Light Bodied Red Wines
12	53.5	Full Bodied White Wines
11	52	Medium Bodied White Wines
10	50	Rosé, Light Bodied White Wines
9	48	Vintage Sparkling
8	53.5	Fino Sherry
7	44.5	Non Vintage Sparkling

General Operating Instructions

Remove all external and internal packaging from your cooler. Be sure that all parts have been included before discarding any packaging materials. You may want to keep the box and packing materials for use at a later date.

Upon receipt and inspection of unit, the supply cord must be replaced if it is damaged. Contact our customer service at 1-800-777-8466 or info@vinotemp.com.

- Let the unit rest, UNPLUGGED for 24 hours once you have it placed in your home.
- Please fully read the instruction manual.

**Please read and follow all safety rules
and operating instructions before using.**



TABLE OF CONTENTS

Parts And Specifications	6
Important Safety Instructions	7
Cord Instructions	8
Cooler Installation	8
Operating Instructions	9
Temperature Control.....	9
Rack Removal / Installation	10
Cleaning And Care.....	11
Moving Your Cooler.....	11
Troubleshooting	12
Terms Of Sale And Warranty.....	13

PARTS AND SPECIFICATIONS

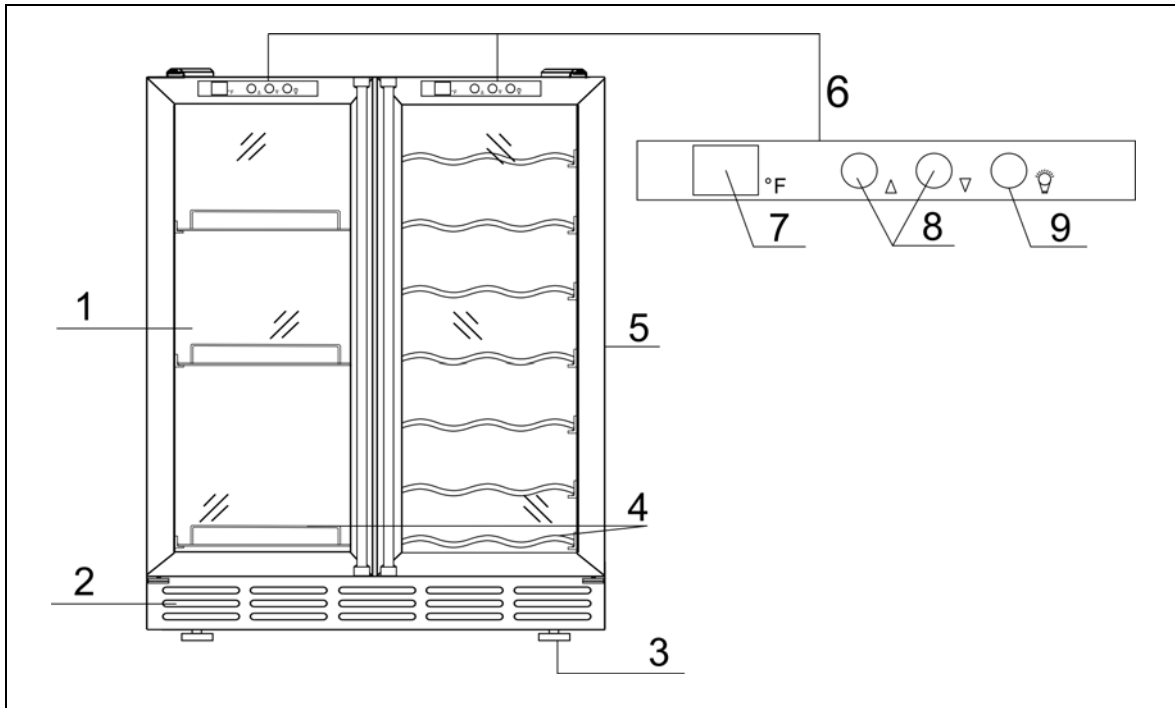

- 1. Double-pane window
- 2. Grill
- 3. Adjustable leveling legs
- 4. Shelf
- 5. Cabinet
- 6. Control Panel
- 7. LED Indicator
- 8. Temperature Adjustment
- 9. Light Switch

Type	2 Temp.
Item Number	VT-38
Dimension (HxWxD)	34.3"×23.9"×22.6"
Weight	153.9 Lbs
Power Consumption	2.1 kW.h/24h
Cooling System	R134a
Temperature Range (for Right Side)	48 ~ 65°F
Temperature Range (for Left Side)	40 ~ 65°F
Rated Voltage	115V
Rated Frequency	60Hz
Input Power	150W



IMPORTANT SAFETY INSTRUCTIONS

When using an electrical appliance, basic precautions should be followed to reduce the risk of fire, electric shock, and personal injury.

1. Use this appliance only as described in this manual. Other users are not recommended and may cause fire, electric shock or injury.
2. This product is intended for household use.
3. To protect against electric shock, do not immerse unit, plug or cord in water or other liquids. Avoid locating the unit in moist areas.
4. Keep away from children.
5. Unplug from the outlet when not in use, when moving from one location to another, or before cleaning.
6. To disconnect the appliance, grip the plug and pull it from the wall outlet. Never pull by the cord.
7. Do not operate the appliance in the presence of explosive and/or flammable fumes.
8. Do not place the appliance or any of its parts near an open flame, cooking or other heating appliance.
9. Do not operate the appliance with a damaged cord or plug. If the product malfunctions, or if it is dropped or damaged in any manner, do not use.
10. The use of attachments is not recommended and may be hazardous.
11. Do not operate if the housing is removed or damaged.
12. A loose fit plug may cause overheating and a distortion of the plug. Contact a qualified electrician to replace loose or worn outlet.
13. This appliance is designed to be built-in (fully recessed) or free standing.
14. This cooler is intended for use in a controlled ambient location such that the ambient temperature does not exceed 90°F (32°C) and is not below 60°F (16°C).
15. Locate the unit away from direct sunlight and sources of heat (stove, heater, radiator, etc.). Direct sunlight may affect/alter the outside color of the appliance.

WARNING: To reduce the risk of fire, electric shock or personal injury, unplug or disconnect the appliance from the power supply before servicing.

WARNING: Risk of child entrapment. Before you throw away your old cooler, take off the door and leave the shelves in place so that children may not easily climb inside.

CORD INSTRUCTIONS

For your protection, this unit is equipped with a 3-conductor cord set that has a molded 3-prong grounding-type plug, and should be used in combination with a properly connected grounding-type outlet as shown in figure A.

It is not recommended to use this cooler with an extension cord or power board. Please ensure that the appliance is plugged directly into the electrical outlet.

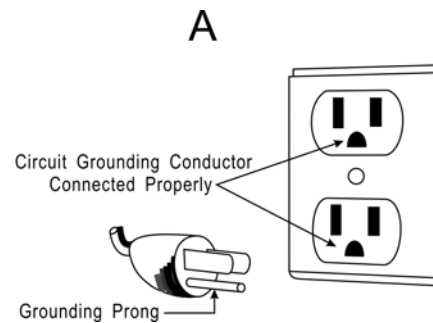

COOLER INSTALLATION

1. This cooler is designed to be built-in (fully recessed) or free standing.
2. Remove all exterior and interior packaging.
3. Place your cooler on a flat surface that is strong enough to support the unit when fully loaded.
4. Do not place the unit in a moist place or display in direct sunlight.
5. Do not place heavy objects on top of the unit.
6. Do not place the unit next to a major appliance that emits large amounts of heat, such as a dishwasher, microwave, oven, etc.
7. Unit is not designed for installation in a garage or basement.
8. Before connecting the appliance to the power source, let it stand upright for approximately 24 hours. This will reduce the possibility of a malfunction in the cooling system due to handling during transportation.
9. Clean the interior surface with lukewarm water using a soft cloth before first use. Be sure to wipe dry.
10. Do not plug unit into the same outlet as a refrigerator or microwave.



OPERATING INSTRUCTIONS

- Plug the power cord into a standard electrical outlet.
- Gently place/slide the racks in the cooler.
- Determine the best temperature setting to use.
- Place bottles inside the cooler.
- Limit the frequency of opening the door to conserve energy and maintain proper storage temperature.

Important: When using the cooler for the first time, allow at least 24 hours for the internal temperature to adjust properly. Make sure there are at least 3 to 5 bottles in the unit.

TEMPERATURE CONTROL

Important note: In order to operate efficiently, unit should be in an environment with an ambient temperature of less than 90°F (32°C).

Temperature Presets:

For your convenience, the cooler is programmed at storing temperature. The temperature zone for the right side pre-set by the manufacturer is 54°F (12°C). The temperature zone for the left side pre-set by the manufacturer is 45°F (7°C).

Setting the temperature control (manually):

You can manually adjust the temperature. Simply press the ▽ button on the control panel to decrease the temperature and the △ button to increase the temperature inside the cooler in 1° increments. The temperature zone for the right side ranges from 48°F to 65°F (9°C -18°C). The temperature zone on the left side ranges from 40°F to 65°F (4°C - 18°C). The variance between compartments can be no more than 18°F (10 °C).

When the cabinet temperature is too low the LED will display "LL". When the temperature is too high it will display "HH". The "ER" display shows when there has been a power disruption.

Both sides of this unit can store wine or beverages, but the left side can be set colder than the right side.

RACK REMOVAL / INSTALLATION

To prevent damaging the door gasket, make sure to have the door all the way opened when pulling shelves out of the rail compartment.

1. Remove any bottles stored on the rack.
2. Grasp the rack, and gently pull it up, then take it out.
3. To reinstall, push the racks into track rails until it completely stops.
(See figure 1)

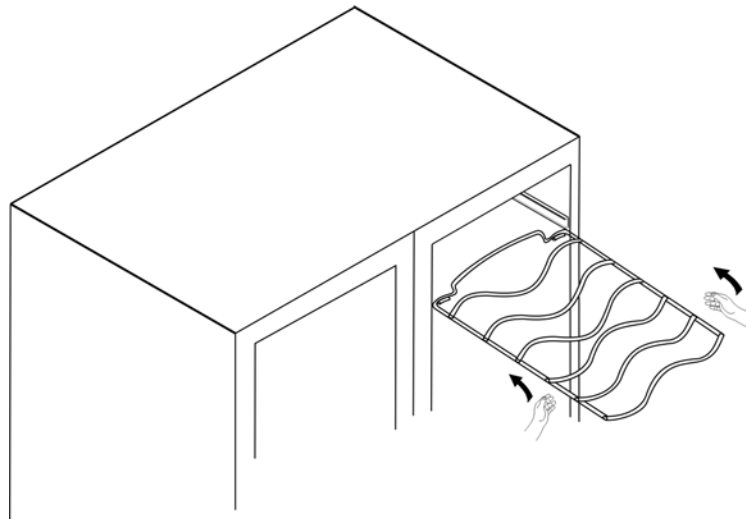

Figure 1

NOTE: Shelves are interchangeable, to store wine or beverage.



CLEANING AND CARE

- Always unplug the cooler before cleaning.
- Do not use benzene, scrubbing brushes or chemical cleaners as these will damage the unit.
- Use only a mild, nonabrasive cleanser to clean the exterior of the cabinet.
- Clean the stainless steel door and handle by wiping with a warm water and baking soda solution. The solution should be about 2 tablespoons of baking soda to a quart of water.
- Wash the racks with a mild detergent solution.
- Always dry all the parts with a clean dry cloth before plugging the cooler back into the receptacle.

MOVING YOUR COOLER

- Always unplug the beverage/wine cooler before moving.
- Always remove all beverages before moving the cooler.
- Securely tape down all loose items (shelves) inside your appliance.
- Turn the levelling legs up to the base to avoid damage.
- Tape the doors shut.
- Be sure the cooler stays in the upright position during transportation
- Protect the outside of appliance with a blanket or similar item as needed.

TROUBLESHOOTING

You can solve many common cooler problems easily, saving you the cost of a possible service call. Try the suggestion below to see if you can solve the problem before contacting Vinotemp at info@vinotemp.com.

SYMPTOM	POSSIBLE CAUSE
Vibrations	<ul style="list-style-type: none"> • Check to make sure the cooler is on a level surface.
Door will not close properly.	<ul style="list-style-type: none"> • The cooler is not on a level surface. • The racks are out of position. • A bottle in the cooler is too long. • The door gasket is dirty.
Fan is always running.	<ul style="list-style-type: none"> • This is simply a function of the cooling system. The lower the setting, the more the fan will run. If the room is warmer than 90°F (32°C), it will run more. • The unit has been designed to run continuously when operating at the lower temperatures.
Unit does not operate—does not have power	<ul style="list-style-type: none"> • Check that unit is plugged into the wall socket. • Make sure the wall socket has power. If outlet is controlled by a wall switch, make sure switch is set to on. Test wall socket functionality by testing another electrical appliance in the power socket.
Power is ON but the unit will not cool.	<ul style="list-style-type: none"> • Make sure there are at least 3 to 5 bottles in the unit. When using the unit for the first time, it can take up to 24 hours to reach the desired temperature. • Make sure the cooling vents are not obstructed. • The room may be too hot. If the ambient room temperature is above 90°F (32°C), the unit can have difficulty chilling adequately and will not get below 51°F (11°C). Humidity does not affect the cooling ability of the unit. • To achieve accurate temperature control, the unit should not be used or operated in any of the following locations: <ul style="list-style-type: none"> ○ In a sunny place ○ In a room with poor air circulation such as a garage near another heat-producing appliance such as a dishwasher, oven or refrigerator. ○ With an outlet shared with a refrigerator, as the refrigerator will drain power from the unit. ○ In a cabinet or closet.



TERMS OF SALE AND WARRANTY

Vinotemp International ("Seller") and the person or entity that acquires these goods from Seller ("Purchaser") hereby fully agree to the following terms and conditions of the sale: Shipping fees are the responsibility of the Purchaser whether freight prepaid or freight collect. Seller assumes no responsibility for the goods sold to the Purchaser once the goods have left the Seller's premises, including, but not limited to, late delivery by the moving carrier, or for events caused by any difficulty carrier incurs in attempting to fit the goods into the Purchaser's place of business or residence due to the size of the goods or otherwise. Purchaser assumes all responsibility for delivery, payment of freight, access, measurement, installation, hook-up, wiring, moving and storage of the goods. The transportation of all goods is subject to the terms and conditions which the moving carrier imposes on Purchaser including, but not limited to, additional charges imposed per flight of stairs, and/or additional charges resulting from the carrier's inability to safely and/or adequately use the building elevator to lift the goods to an upper floor. Any claim for damages incurred during shipment by the carrier of the goods are insured and handled directly with the carrier. Any damages due to manufacture defects will be handled directly with Vinotemp International, subject to the limited warranty.

All sales are final, and unless authorized in writing by the Seller, Purchaser may not return the goods, under any circumstance. If Purchaser refuses to accept the goods, under any circumstance, the Purchaser is liable for the return and cost of freight both ways, and if Seller does take back the goods, there will be a restocking charge that is 35% of the purchase price of the goods. Purchaser must notify Seller of non-conforming goods within four days of delivery, after which time all goods are deemed accepted.

If Purchaser tenders payment with a check that has insufficient funds (NSF), or stops payment on a check or credit card for any reason, Purchaser agrees to pay for all costs associated with the Seller's connection or litigation of such a claim, including without limitation extra damages, court costs and attorneys' fees. Finance charges begin the date of invoice. Collection fees plus NSF fee of 50\$ will be added to your invoice, which you agree to promptly pay. Title to the goods does not pass until payment is received in full by Seller and Seller retains a security interest in the goods until they are paid for in full.

LIMITED WARRANTY: Seller warrants that the goods will be free of defects in materials and workmanship as follows: Metal cabinet wine, beverage, refrigerator and freezer units: parts and labor for cooling system and cabinetry for a period of 12 (twelve) months from date of sale, removal and re-installation of unit is not included in warranty. For a scratch and dent or refurbished unit, warranty is 3 months from your dated invoice (parts for function only, not cosmetic). There is no warranty on parts purchased separately. Purchaser's exclusive remedy is limited, at Seller's option; to repair or replace defective part[s] with either new or factory reconditioned part[s]. Purchaser is responsible for shipping the unit pre-paid to designated facility and Seller will pay return shipping charges in the continental United States for items repaired under warranty within 12 months from date of sale. Improper placement of the unit will void the warranty. This limited warranty does not cover damage due to such things as accident, misuse, abuse, mishandling, neglect, acts of God, fires, earthquakes, floods, high winds, government, war, riot or labor trouble, strikes, lockouts, delay of carrier, unauthorized repair, or any other cause beyond the control of the Seller, whether similar or dissimilar to the foregoing. Seller is not responsible for any damages caused to Seller's property resulting from the good. This limited warranty applies only inside the Continental US. (Alaska, Puerto Rico and Hawaii are not warranted).

Purchaser understands and acknowledges that the goods sold here are wine cellars and/or other similar units which house beverages. Purchaser assumes all risk of using these units, including risk of spoilage, humidity variations, temperature variations, leaks, fire, water damage, mold, mildew, dryness and similar and any other perils that might occur.

Seller is not responsible for incidental or consequential damages, and there are no warranties, expressed or implied, which extend beyond the Limited Warranty described above. The implied warranties of merchantability and of fitness for a particular purpose are hereby expressly disclaimed. Some states do not allow the exclusion of incidental or consequential damages, or a waiver of the implied warranties of fitness and/or merchantability, so the above limitations may not apply to you. This warranty gives you specific legal rights and you may also have other rights which vary from state to state.

In the event of any dispute between Seller and Purchaser arising out of or relating to these terms and conditions or to the goods sold generally, Purchaser must first file a written claim with Seller within ten days of the occurrence giving rise to the claim and wait an additional thirty days for a response before initiating any legal action. The sale and all terms are subject to California law. Any legal proceeding arising out of or relating to these terms and conditions or to the goods sold generally shall be brought solely and exclusively in the County of Los Angeles. In no event may Purchaser initiate any legal proceeding more than six months after the occurrence of the event giving rise to the dispute.

The above terms and conditions are the only ones governing this transaction and Seller makes no oral representations of any kind. These Terms and Conditions can only be modified in writing, signed by both Purchaser and Seller. 07/08

SERVICE & IMPORTANT NOTICE

Upon receipt and inspection of unit, the supply cord must be replaced if it is damaged. Contact our customer service at 1-800-777-8466 or info@vinotemp.com.

The manufacturer has a policy of continuous improvement on its products and reserves the right to change materials and specifications without notice.

WARNING

**Please do not place the unit within reach of children.
For adult use only.**

Contact **info@vinotemp.com** with any questions or visit:

www.vinotemp.com



W W W . V I N O T E M P . C O M



17621 S. Susana Road
Rancho Dominguez, CA 90221
www.vinotemp.com

Vinotemp is a registered trademark of Vinotemp International. All products, features, and services are subject to change without notice. We cannot guarantee the accuracy of the contents of this document. We disclaim liability for errors, omissions, or future changes.

© 2008 Vinotemp International. All rights reserved.