

24V Temperature and Humidity Control WM-CTCONTROL-WIFI



NOTE: This thermostat must be installed inside a wine cellar

You can use this touchscreen Wi-Fi thermostat to

- 1- Maintain a wine cellar at perfect temperature for long-term storage of wine.
- 2- Monitor temperature and humidity anywhere through the Internet.
- 3- Set up notifications of abnormal temperature and humidity through email or text message
- 4- Protect your wine from freezing at low ambient temperature by automatically turning on heater.
- 5- Keep desired higher humidity by automatically circulating air all times.

1. Initial Settings

When the thermostat is powered first time, touch “Next” on the screens below to select the default settings.



Your thermostat location

Location Name (press to edit)

THERMOSTAT

Back **Help** **Next**

Your thermostat controls

Cooling

Heating

Back **Help** **Next**

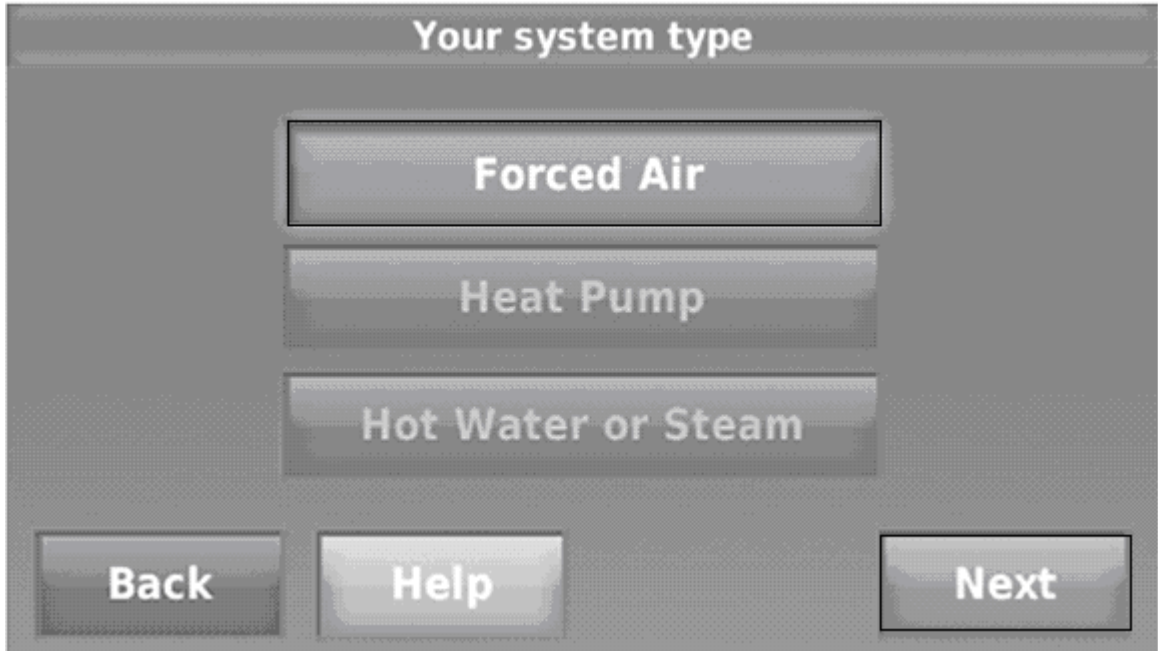

On the screen below, touch "I'll do it later" to skip the Wi-Fi network connecting.



Note: If the screen is locked, touch MENU and select “Security Settings”, select “Change Lock Mode”.

2. Setting the fan

Touch FAN to display the following options. Then select “Automatic” and “Done”

Note: Select “Circulate” to maintain higher humidity.

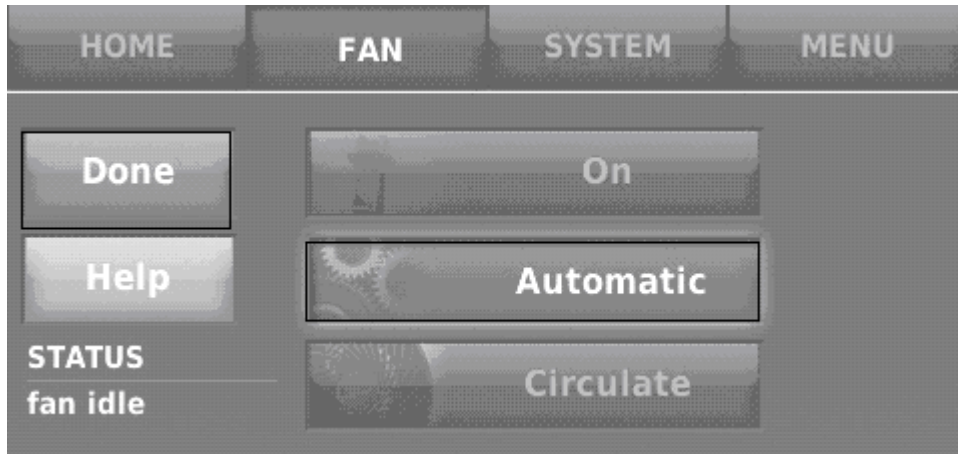

3. Setting the system

Touch SYSTEM to display the following options. Then select “Cool” and “Done”

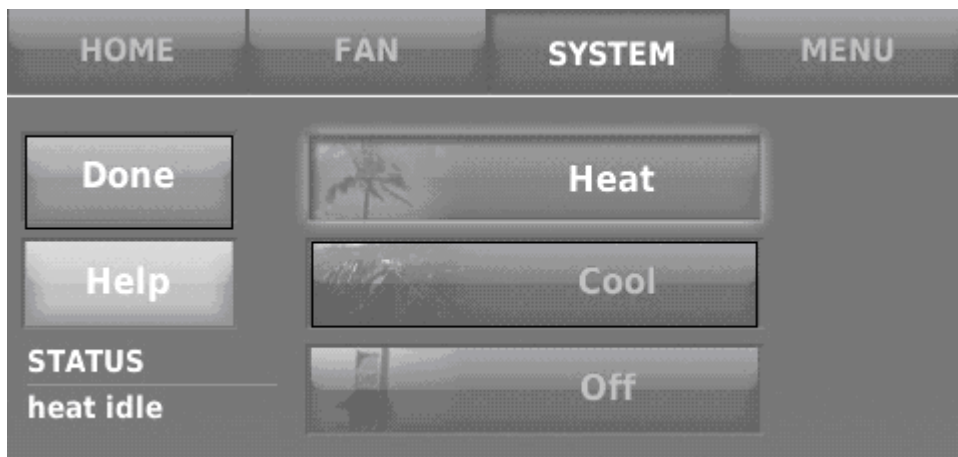

4. Setting the preferences

Touch MENU to display the following options. Then select Preference > Advanced Preferences.

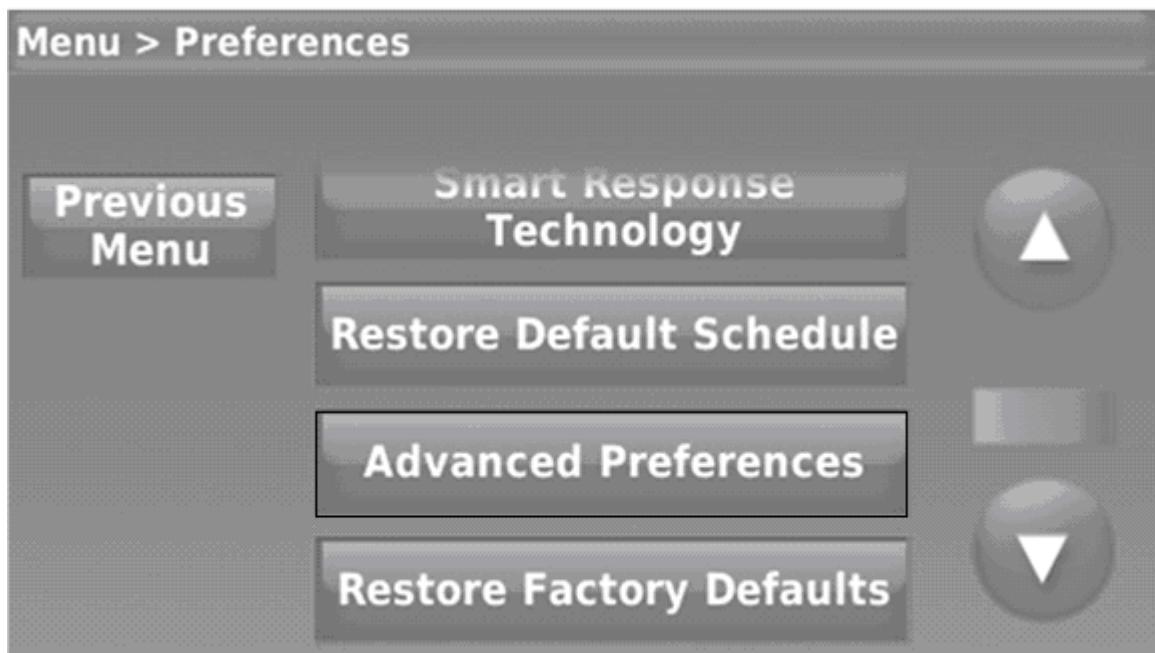

On each screen, make changes as follows. Then save all the changes.

Preferences	Settings
Scheduling Options	Non-Programmable
Temperature Indication Scale	Fahrenheit
Heating and Cooling System Changeover	Manual
Temperature Limits	Min Cool 50F; Max Heat 45F
Keypad Lockout	Partially Locked
Clock Format	12 Hour
Daylight Saving Time	Off
Indoor Display Offset	Temperature 0F; Humidity 0%

5. Setting the date and time

Touch “Set the date and time” or the current date and time to display the following options. Then change time and date.



6. Setting Wi-Fi

Touch MENU to display the following settings. Then select “Wi-Fi Setup”. Select your Wi-Fi network, type your password. When the Wi-Fi has been connected successfully, your thermostat MAC ID and CRC numbers will be displayed on the screen.

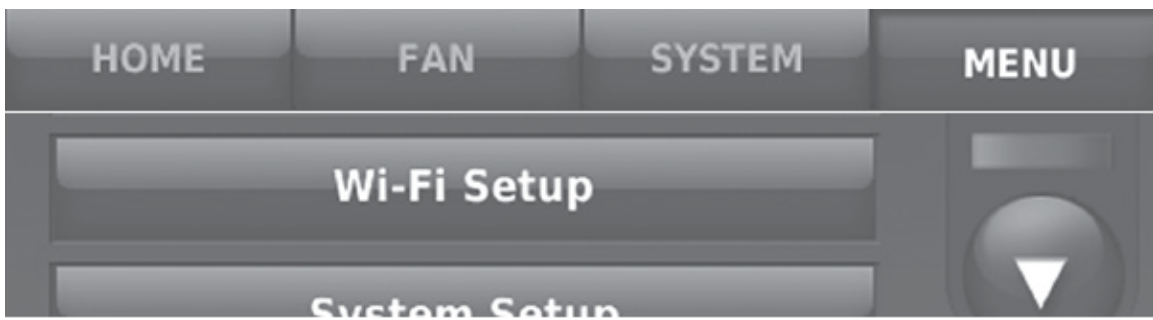
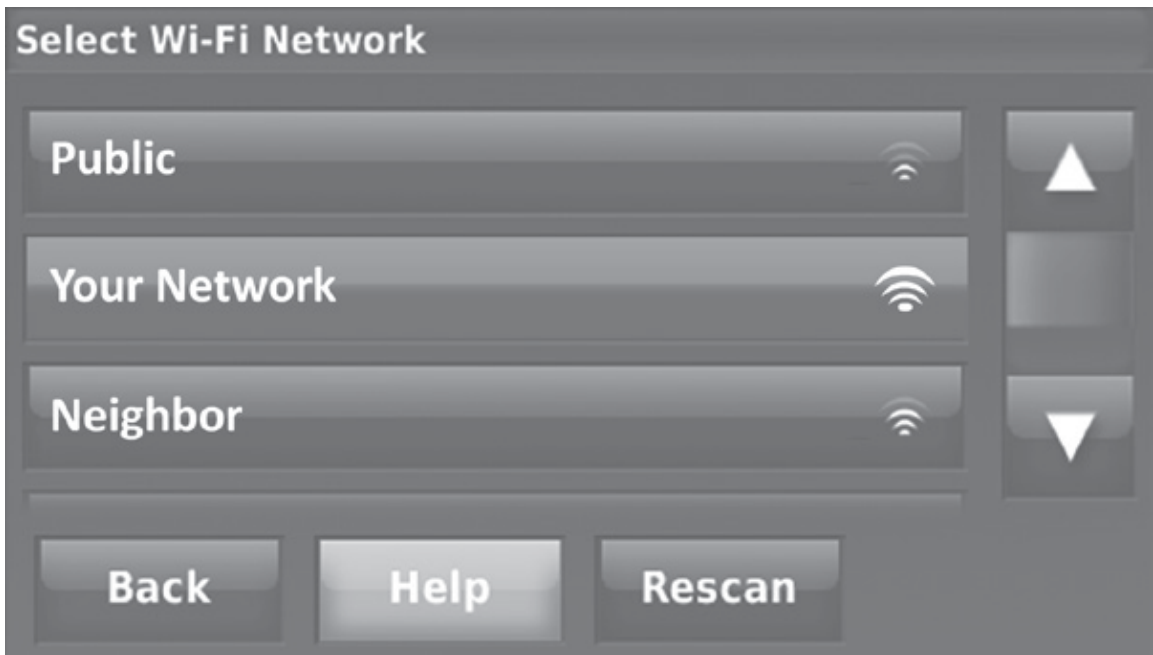

7. Registering your thermostat online

Visit www.mytotalconnectcomfort.com to setup your thermostat for remote access.

When your account has been created successfully, you will be able to access your thermostat remotely with your email address and account password.

You can monitor and control the cellar temperature anywhere. You can set up notifications of low & high temperature and low & high humidity.

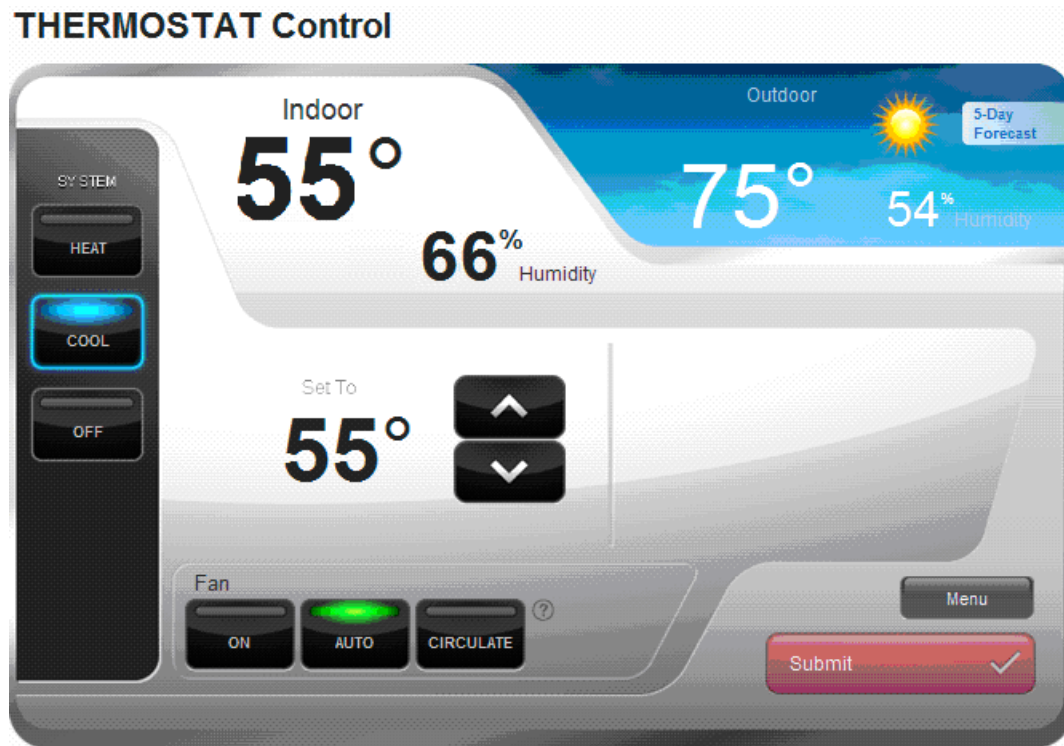

8. Electrical Wiring Diagrams

CAUTION	<p>Hidden lines are the field wirings</p> <p>Use minimum 14 gauge wires for power lines.</p> <p>Use 18 gauge wires for thermostat and sensor.</p> <p>If equipped with low ambient condition kit, use low ambient temperature wiring diagrams.</p> <p>A safety switch is always recommended for the condensing unit.</p>
----------------	---

NOTE	<p>W is 24VAC output for HEATING relay.</p>
-------------	---

1) FAN COIL 120V Electrical Wiring (WM-SFCD, WM-SFCI, WM-SFCL, WM-SFCO, WM-SFCS, WM-SFCW)

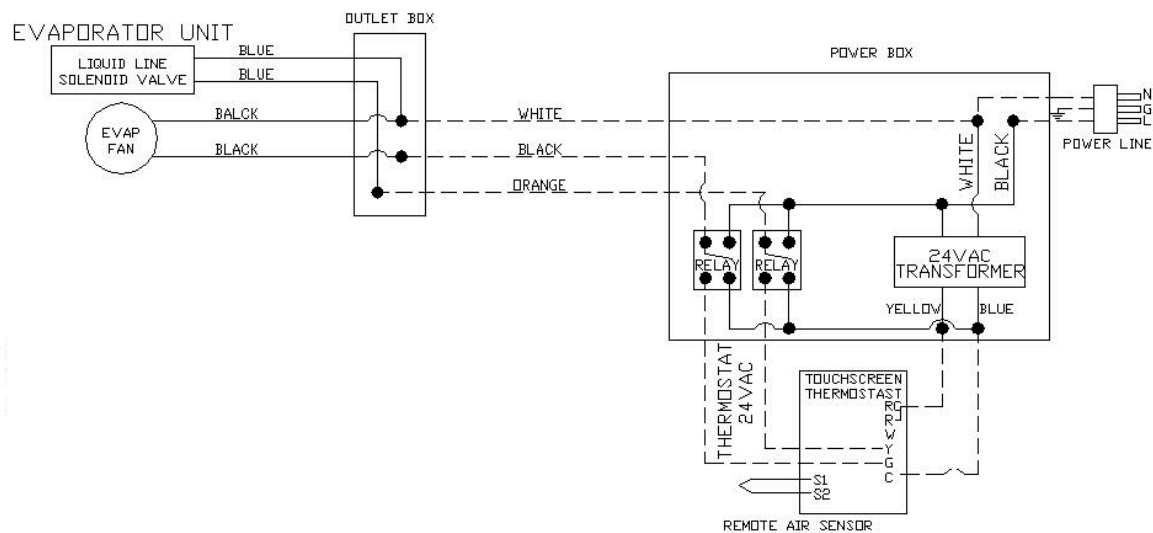

2) AIR HANDLER 120V Electrical Wiring (WM-SFCA, WM-SFCH, WM-SFCR, WM-SFCV)

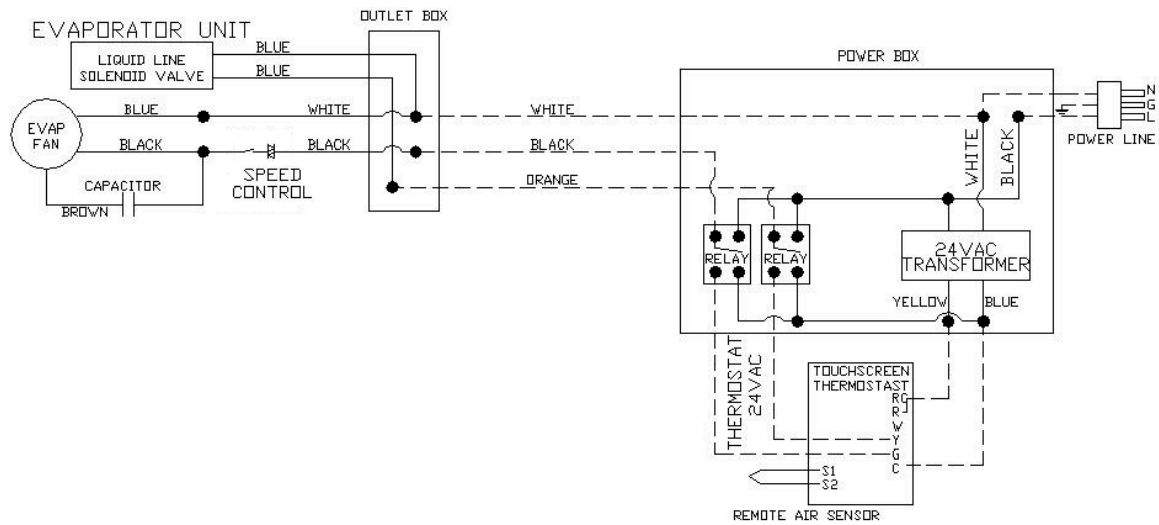

3) CONDENSING UNIT 120V Electrical Wiring (WM-150~450SCUR)

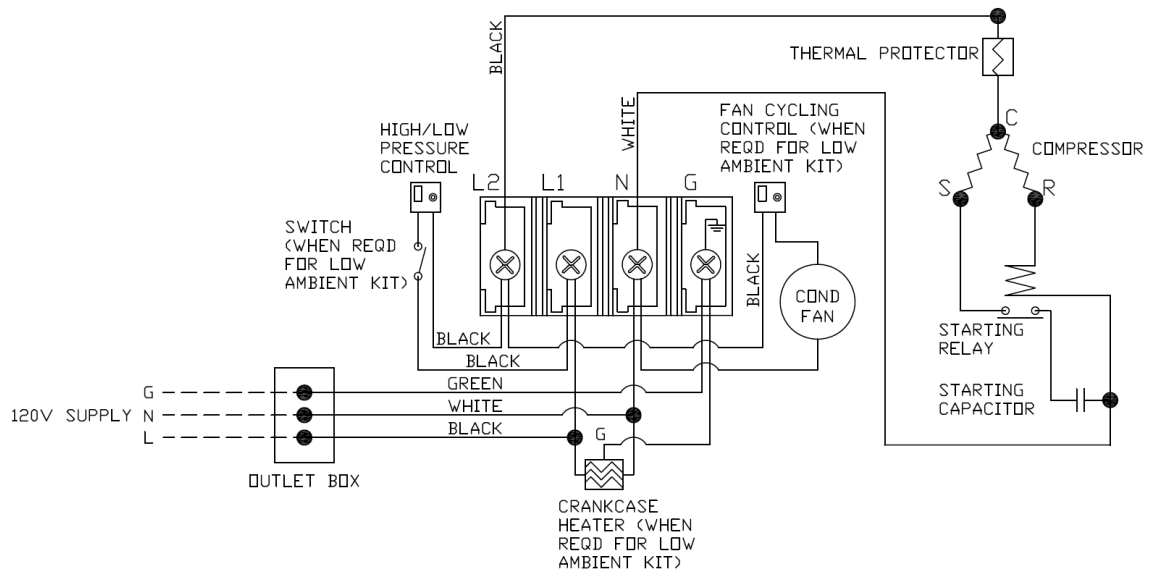

4) CONDENSING UNIT 120V Electrical Wiring (WM-650SCUR)

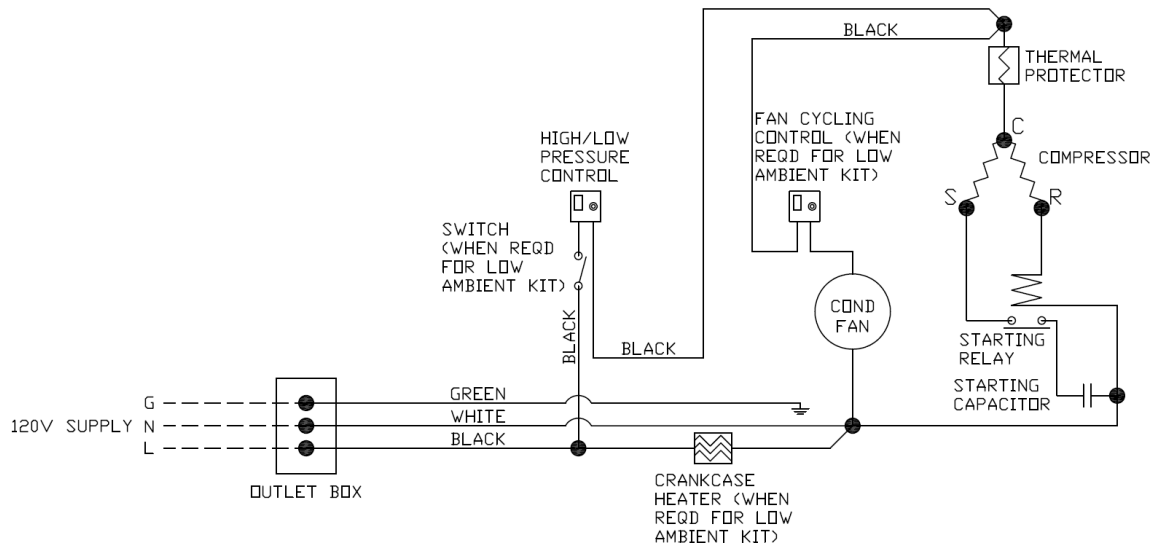

5) CONDENSING UNIT 120V Electrical Wiring (WM-850SCUR)

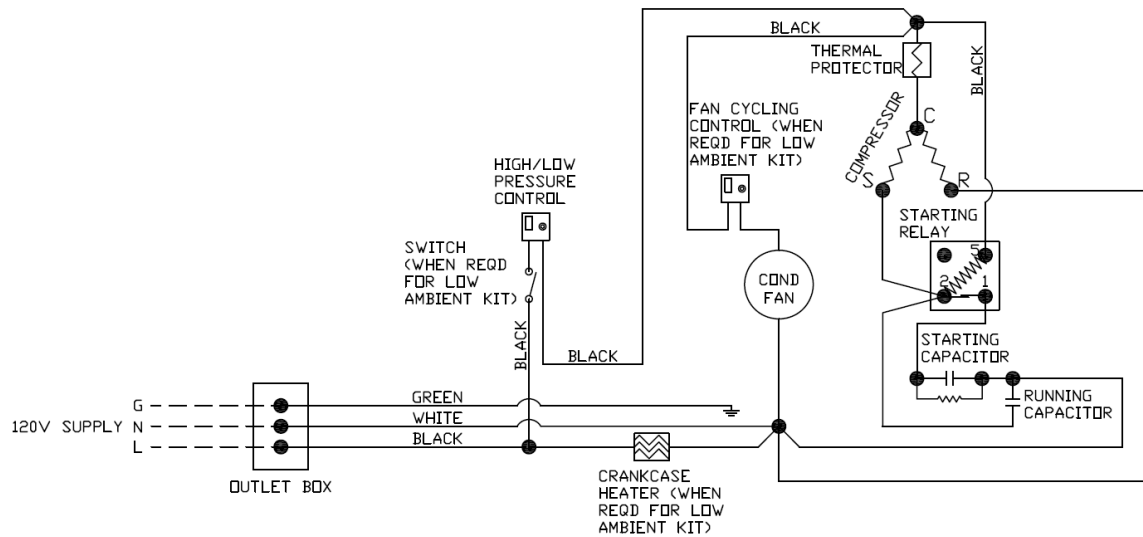

6) CONDENSING UNIT 230V Electrical Wiring (WM-1203SCUR)

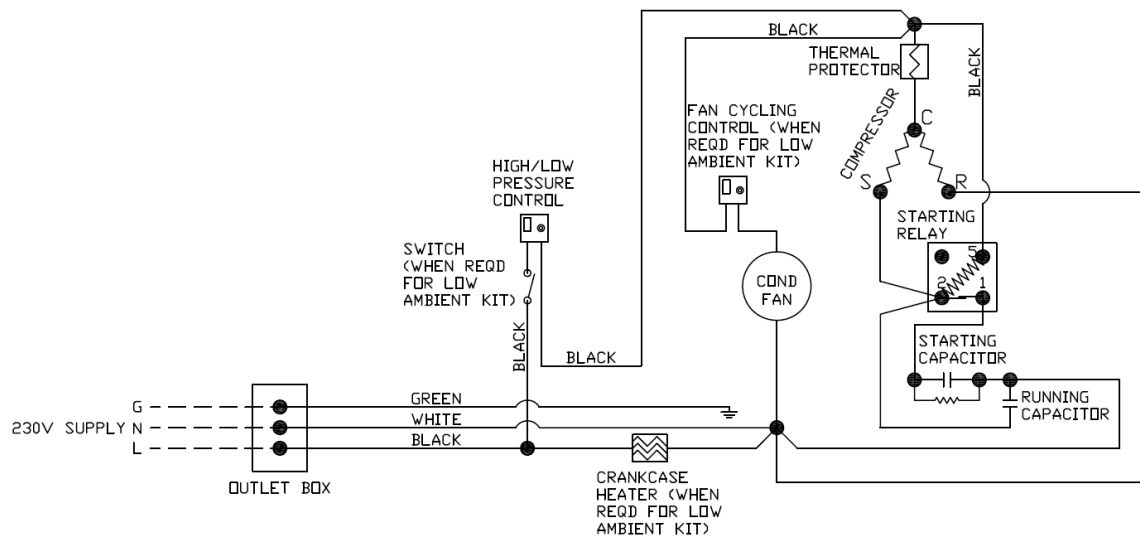

7) CONDENSING UNIT 120V Electrical Wiring (WM-250~650SCUR-WC)

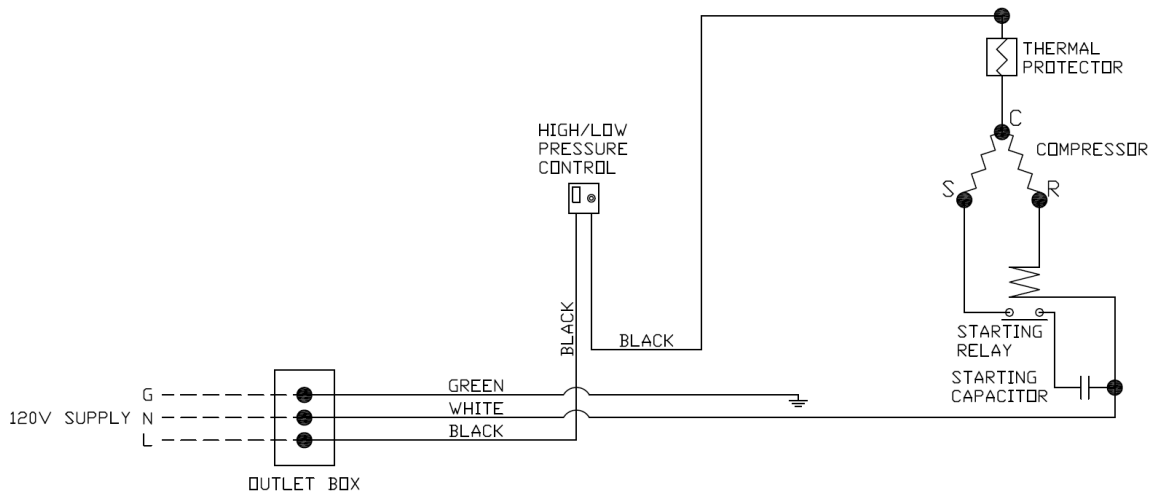

8) CONDENSING UNIT 120V Electrical Wiring (WM-850SCUR-WC)

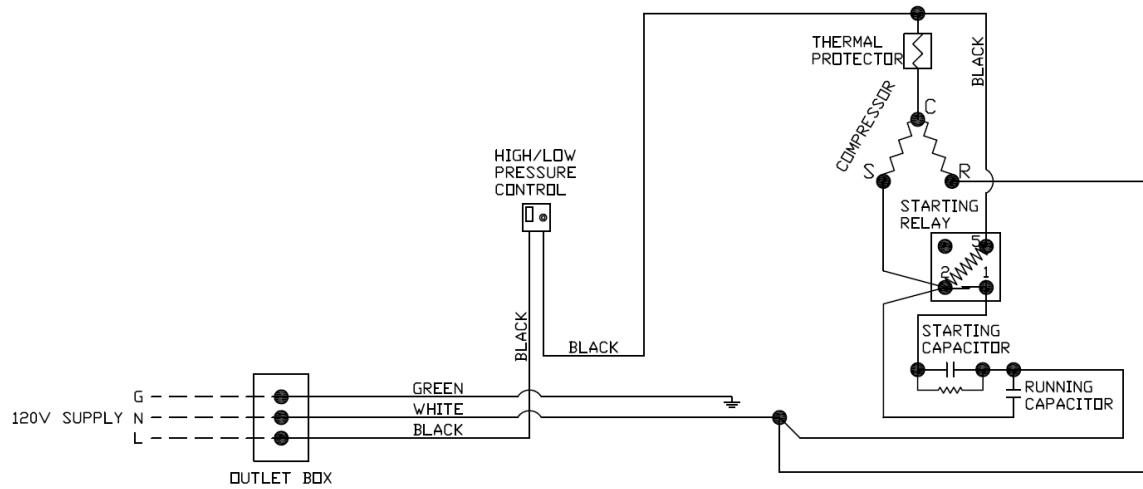

9) CONDENSING UNIT 230V Electrical Wiring (WM-1203SCUR-WC)

