

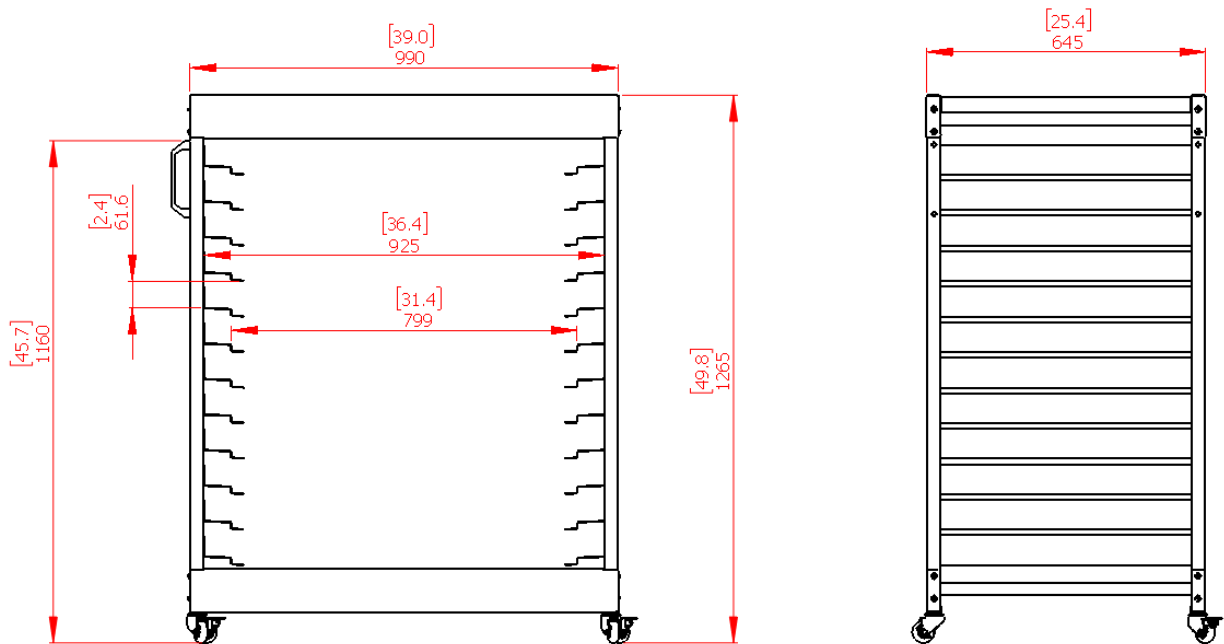

Dimensions:



Box Contents:

ITEM NO.	Part Description	QTY.
1	End Frame Assembly	2
2	Rack Spacer Channel	2
3	Top Tray	1
4	50mm Swivel Castor - No Brake	2
5	50mm Swivel Castor - Braked	2
6	M10 x 30 x 30 - Socket Cap Screw	4
7	M8 x 20 Socket Button Head Screw	16
8	Black GRP Bridge Handle - Caphead Screw Fitting	2
9	M8 x 25 x 25 Socket Cap Screw	4

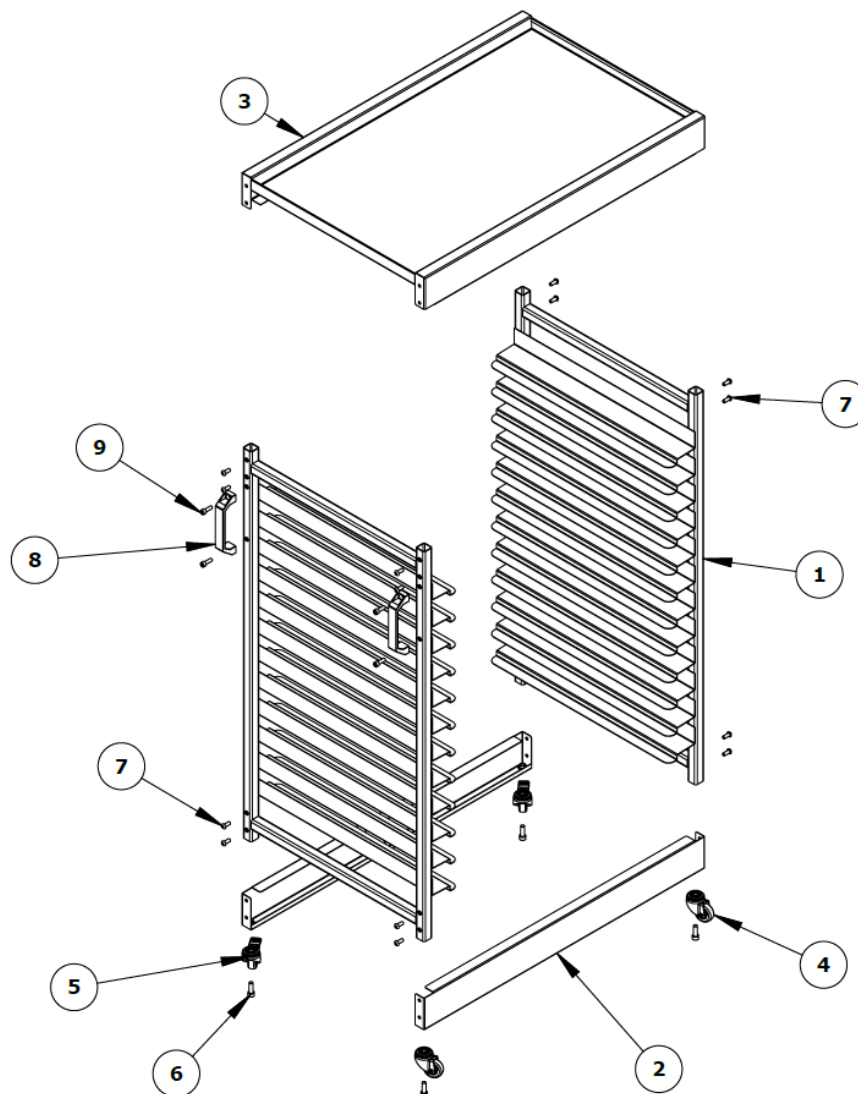

1

Lay Top Tray upside down on a clean, protected, surface.

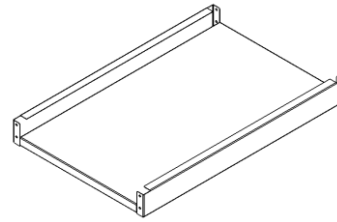

2

Pick up one End Frame and insert it into the slots in the Top Frame. Ensure that the bolt holes for the handles are nearest to the Top Tray

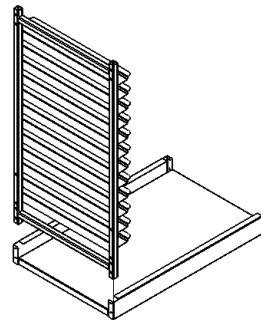

3

Fix into place using 4 off M8 x 20mm Socket Button Screws.

*Do not fully tighten screws at this stage.*

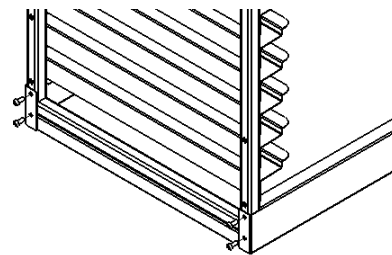

4

Repeat for the other end frame.

*Do not fully tighten screws at this stage.*

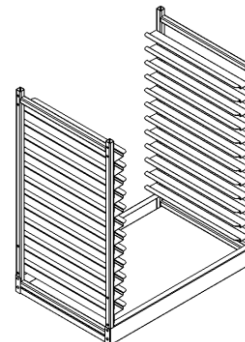

5

Pick up one Rack Spacer Channel and locate it onto the End Frame so that the End Frames fit into the slots in the Rack Spacer Channel and the threaded inserts are uppermost.

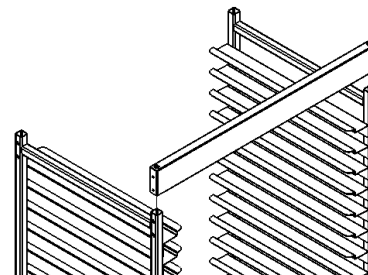

6

Fix into place using 4 off M8 x 20mm socket button screws.

*Do not fully tighten screws at this stage.*

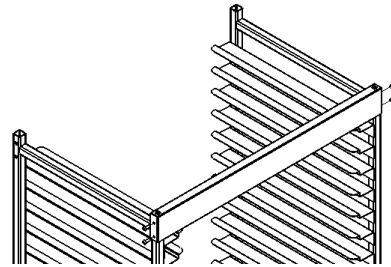

7

Repeat for the other Rack Spacer Channel.

*All screws can now be fully tightened.*

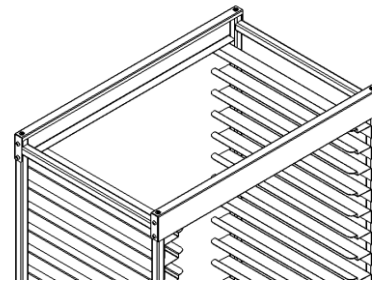

8

The Screen Print Essentials drying rack is supplied with two braked castors and two un-braked castors. These can be positioned as per your requirements.

Fix castors into place using 4 off M10 x 30mm socket cap head screws.

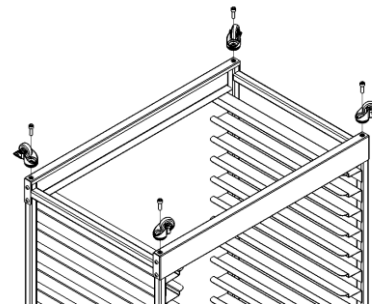

9

Fit the two handles on the required end using the M8 x 25mm socket cap head screws.

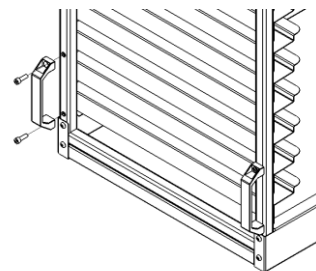

10

Turn trolley on to castors and it's ready to use.

