

VINdustry Pegs: Installation Instructions

Standard Bolts

Step 1: Drill 1/4" (6mm) holes

Step 2: Put bolt through the back of the panel

Step 3: Thread peg onto the bolt through the front of the panel

We recommend using z-clips (french cleats) for mounting your panel when using standard bolts

IMPORTANT NOTE:

**Standard bolts can only be used when you have access to the back of your panel
-If you do not have access to the back of your panel anchor bolts will need to be purchased**

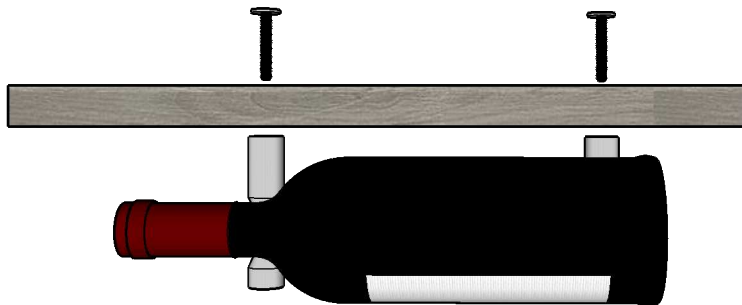

Blue Grouse Wine Cellars

604.929.3180

1.888.400.CORK(2675)



VINdustry Pegs: Installation Instructions

Anchor Bolts

Choose Your Anchor Bolt Length:

50mm Anchor Bolts – choose these if mounting directly into your wood surface. They can also be used if your plywood or MDF substrate material is clad with up to 10mm of other material you must drill through first (eg. 10mm acrylic material on top of plywood backing).

70mm Anchor Bolts – choose these if your plywood or MDF substrate material is clad with a thicker material, up to 30mm, you must drill through first (eg. 30mm of tile on top of plywood backing).

Traditional Installation Method

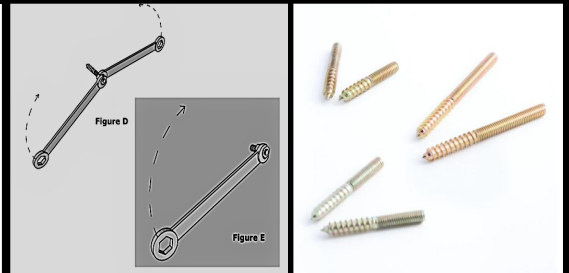

Installing Your Anchor Bolts - Traditional Installation Method:

Step 1: Drill 5/32" (4mm) pilot holes

Step 2: Thread two nuts onto the fine threaded end of one anchor bolt, using two wrenches, tighten the nuts against one another (Figure D)

Step 3: With the nuts tightened against each other, use one wrench on the outer nut and thread the anchor bolt end into the pilot hole in the wall

Step 4: Screw the bolt into the wall until the coarse threads of the anchor bolt end are no longer visible, leaving just the finer threads exposed (Figure E)

Step 5: Again using two wrenches, loosen the nuts and remove them to repeat the process for the second anchor bolt

Step 6: Thread the peg onto the exposed bolt through the front of the panel

Faster Installation Method

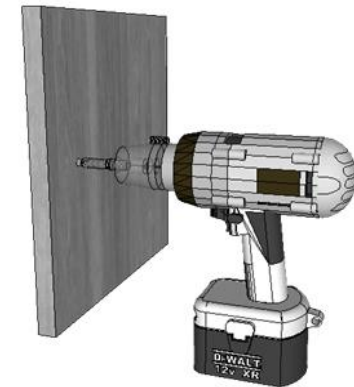

Faster Installation Method: Purchase an anchor bolt driver: fit the anchor bolt driver into an electric drill, screw anchor bolt into driver and then drill into your pilot hole. Be careful not to screw too deep. Leave sufficient bolt length sticking out of the wall for mounting the peg.

Blue Grouse Wine Cellars

604.929.3180

1.888.400.CORK(2675)

