

## Instructions to Set Up Your VELOWAVE RANGER/GHOST

### Diagram

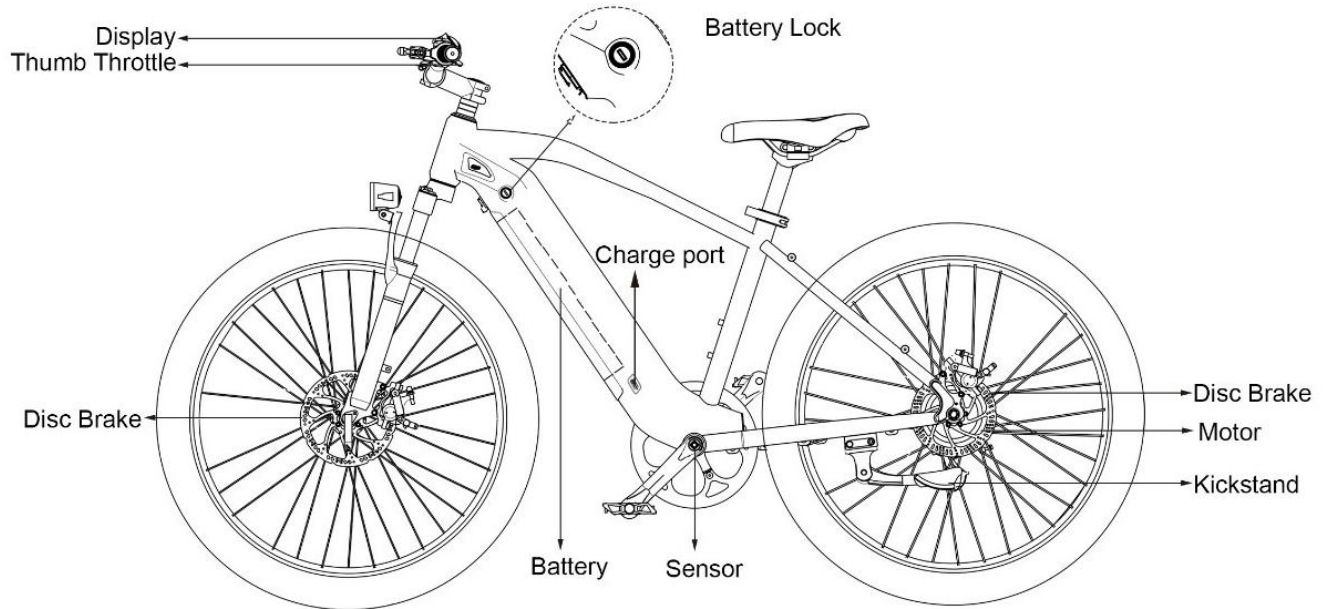

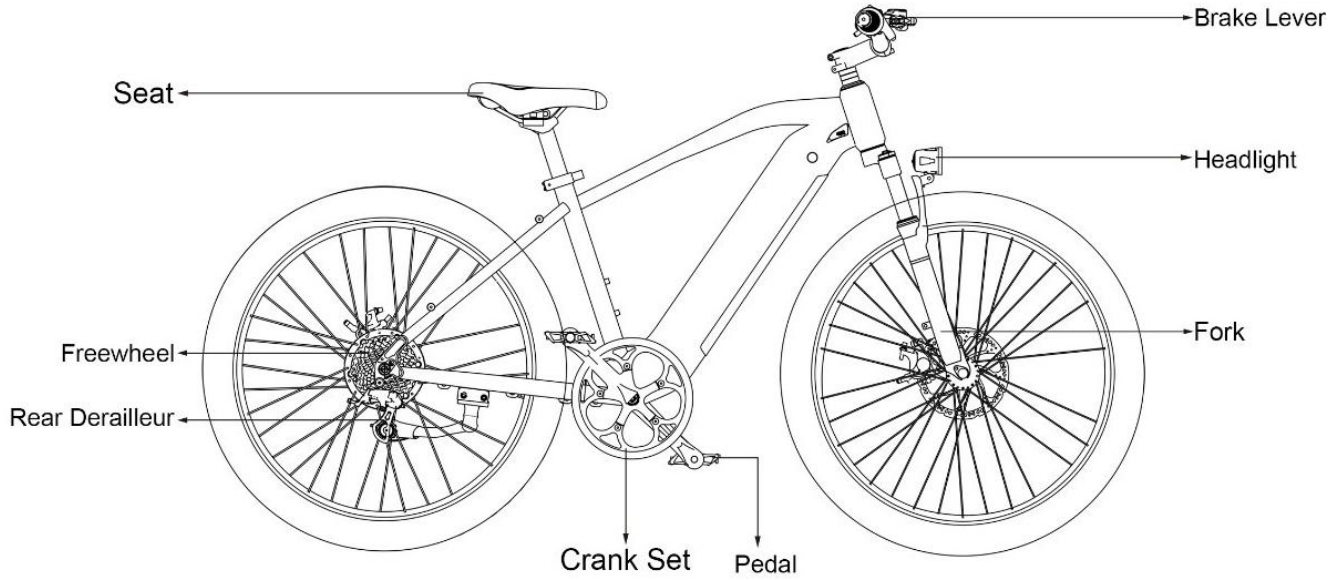

**We know you are excited about getting going but please:**

- ✓ Reseat and charge the battery before the first ride
- ✓ Make sure the pedals are tight
- ✓ Make sure the front wheel is installed properly and tight
- ✓ Inflate the tires properly
- ✓ Check that all screws are properly torqued
- ✓ Carry out a fine adjustment of the gears and brakes
- ✓ Learn how to use the LCD display
- ✓ Wear a helmet before riding

Please Note: Bike may need further adjustments after assembly

---

**If you have any trouble with setup, please contact us online or through our email address: [support@velowavebikes.com](mailto:support@velowavebikes.com)**

**Please always include your order ID when reaching out to us.**



## Assembling Your E-Bike

- 1) **Read all of the instructions carefully.** Be familiar with the proper operation of all items.
- 2) This quick guide is intended to list the steps needed to assemble your bike with some mechanical skills. It is not a complete manual or training. If you do not feel comfortable or lack some of the skills to assemble it yourself, reach out to a cyclist friend, a local bike mechanic or one of our support technicians for guidance.
- 3) Our QA mechanics have assembled and tested your bike beforehand.
- 4) To assemble your bike, work on a clean area with enough space to maneuver.
- 5) If installed, remove the battery from the bike to start the assembly.
- 6) Inspect the bike completely to be sure no damage occurred during shipping.
- 7) The kickstand is designed to support the bicycle only. Not the rider mounted.
- 8) You can adjust your saddle position and the tilt on your handlebar items for comfort.
- 9) Check all screws and parts are tight and properly fixed. We recommend a pre-trip inspection before your first rides.

## Installing Your Handlebars

- 1) Point the headset towards the front of the bike.
- 2) Place the handlebar in the handlebar mount being careful with the wires.
- 3) Face the mounting brackets on the front end of the mount with the round edges facing outward. Insert the screws into the screw holes and tighten alternating sides until secure (4mm allen wrench with 6N strength).
- 4) Verify your front tire lines up with your headset.
- 5) Tighten screws on stem end (4mm allen wrench with 6N strength) and top of the stem (5mm allen wrench with 6-8N strength).
- 6) Check all headset items are tight.

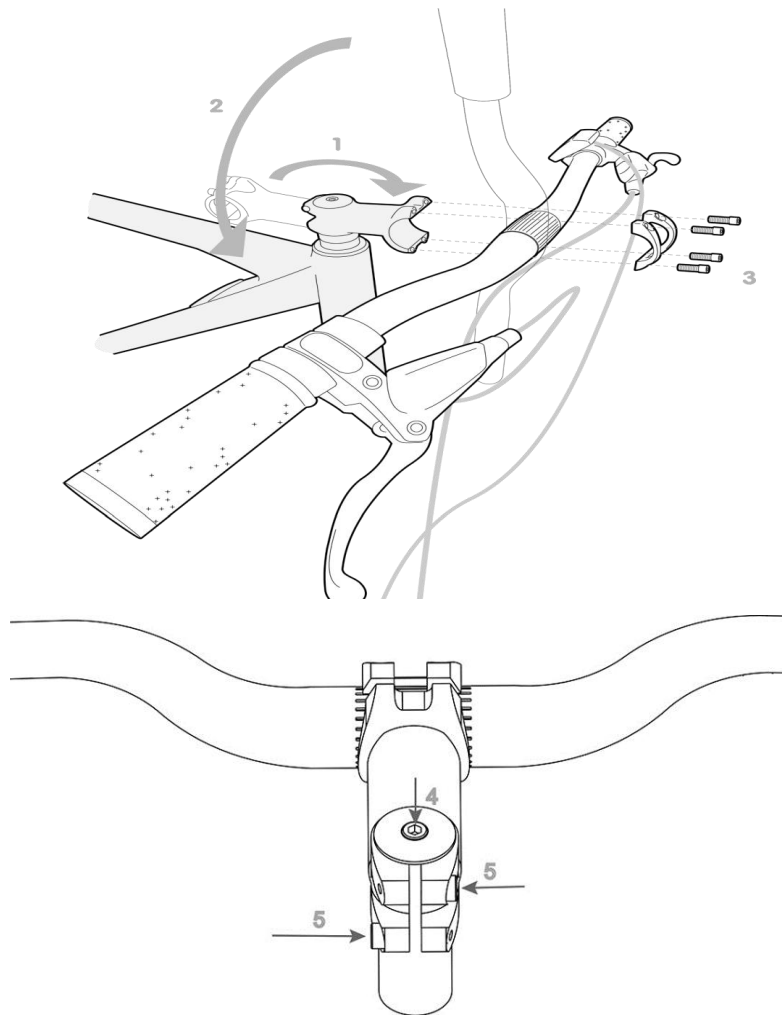

## Installing Your Front Wheel

- 1) Insert the front wheel in between the front fork on the bike. Be sure the fork is resting on the outside of the axle.
- 2) Align the disk between the brake caliper as shown in Figure 2.
- 3) Insert the skewer into the wheel axle as seen shown. Keep the spring, cam follower, and lever on the **LEFT** side, nearest the disk brake. Keep the adjustment nut and spring on the **RIGHT** side. (See Figure 2)
- 4) Screw the skewer into the end nut until almost tight.
- 5) Lift the lever up until parallel with the front fork. You should feel the axle tighten into the front forks. Your front wheel is now installed.

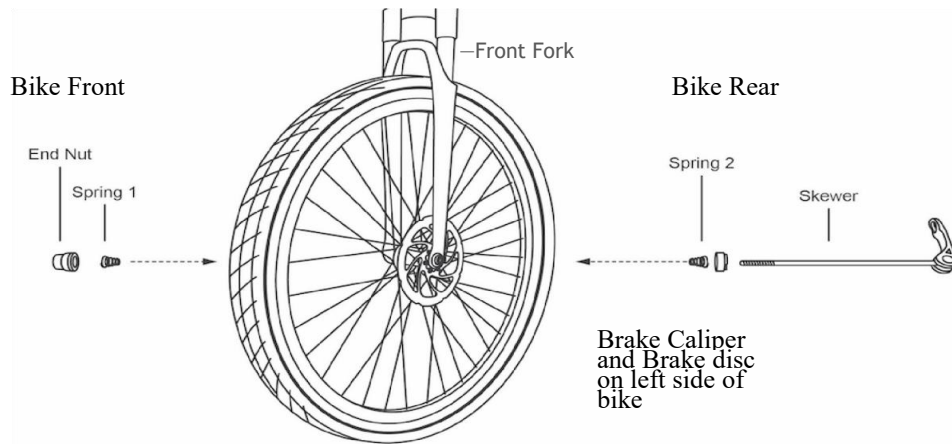

Figure 1

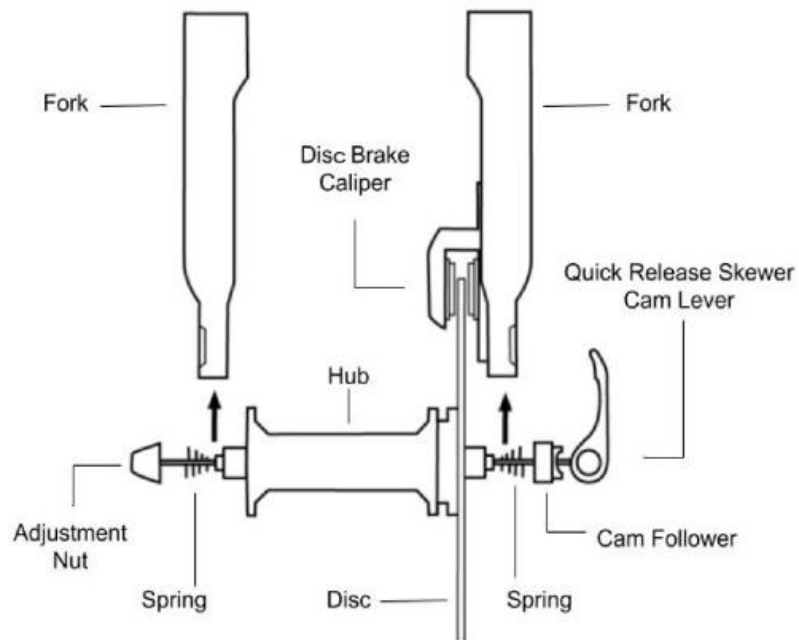
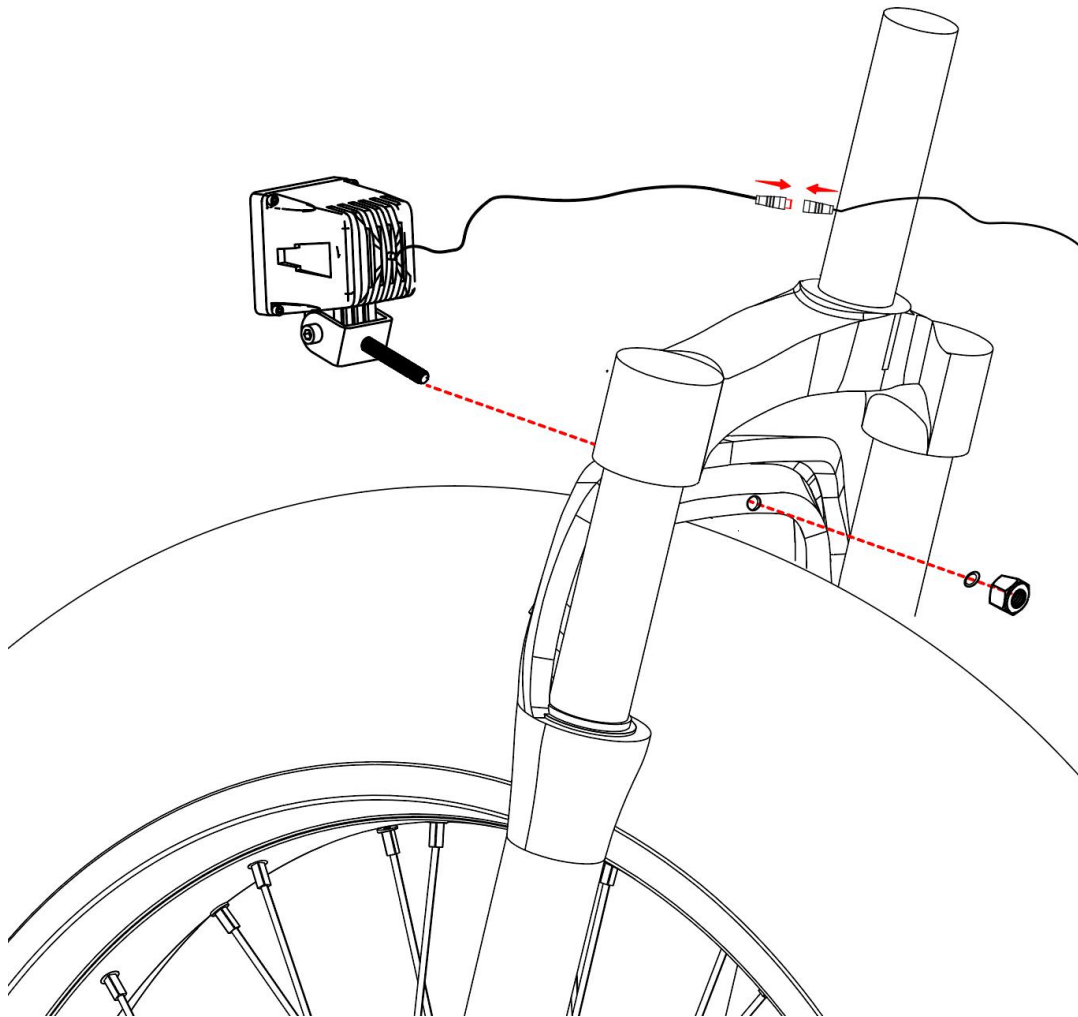

Figure 2

## Installing Your Headlight

- 1) Place the headlight with its bracket in front of the fork gantry. Push the screw provided on the headlight through the installing hole on the fork gantry. Tighten the fixing nut onto the screw. (You might need to secure the fixing nut tightly so the screw doesn't turn).
- 2) Connect the headlight cable with the wire coming from the downtube.



## Installing Your Pedals

- 1) **Warning:** Incorrect installation will cause damage. Please read the instructions and watch our videos if needed.
- 2) Identify the Left and Right markings on the pedals. They can only be installed in their respective side.
  - a. L is for the Left Pedal and it goes on the Left Crank Arm.
  - b. R is for the Right pedal and it goes on the Right Crank Arm (Chain Side).

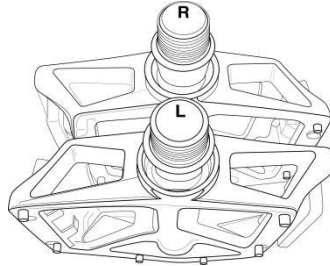

- 3) Sitting on your bike the pedals go on the Left and Right side respectively.
- 4) Keep the pedal Horizontal while hand screwing to get the thread started. Then Use your 15mm wrench to tighten them.
- 5) Both pedals tighten towards the front of the bike. The left pedal is reverse threaded to allow this.
- 6) **The pedals need to be very tight, be sure to retighten after your first couple rides.**

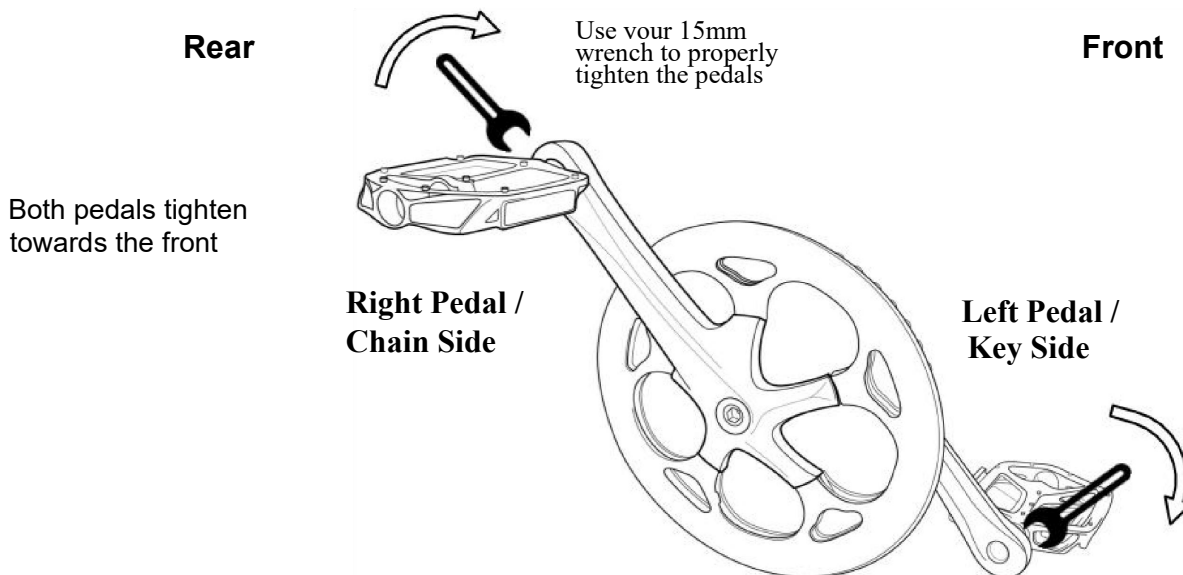

Wrench icon made by Gregor Cresnar from [www.flaticon.com](http://www.flaticon.com)

## Installing and Removing the Battery

### To Install the Battery

- 1) Turn the key counterclockwise to release the lock.
- 2) Seat the bottom of the battery into the receptacle first and push the upper side of the battery into the frame tightly until it gets locked with a clatter sound. Seat your battery securely, turn the key clockwise to lock the battery. Remove the key from the lock before each use.

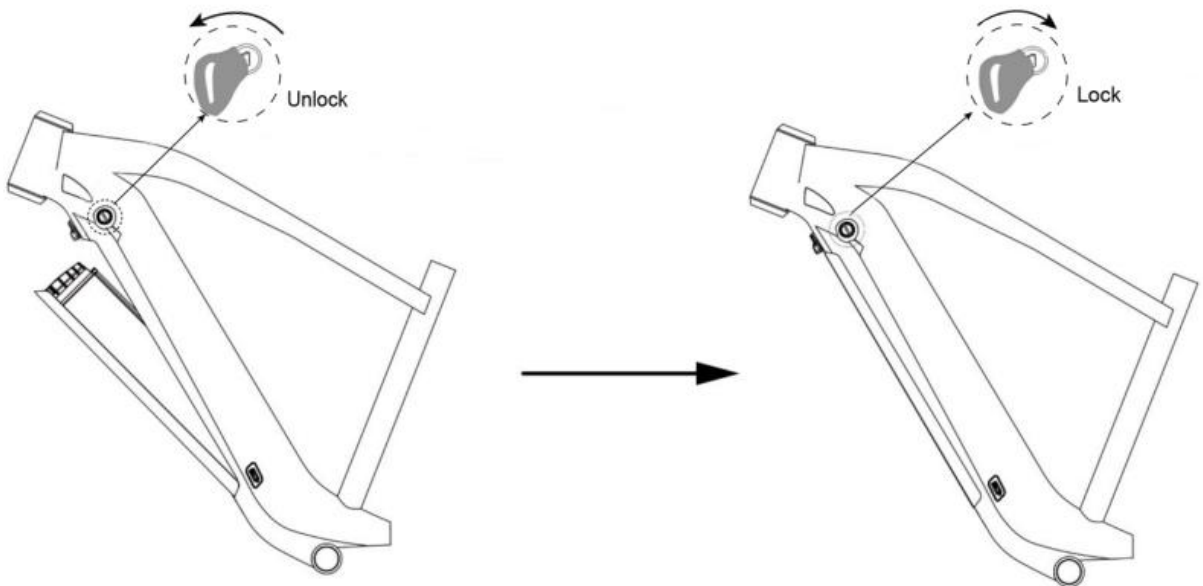



## To Remove the Battery

- 1) Turn off the LCD display.
- 2) The battery is secured with a double-lock mechanism. Use the key to release the first lock. Push slide the plastic tab under the tube to release the second lock.

Note: Please hold the battery tight with one hand at least as it will drop off when the lock is released.

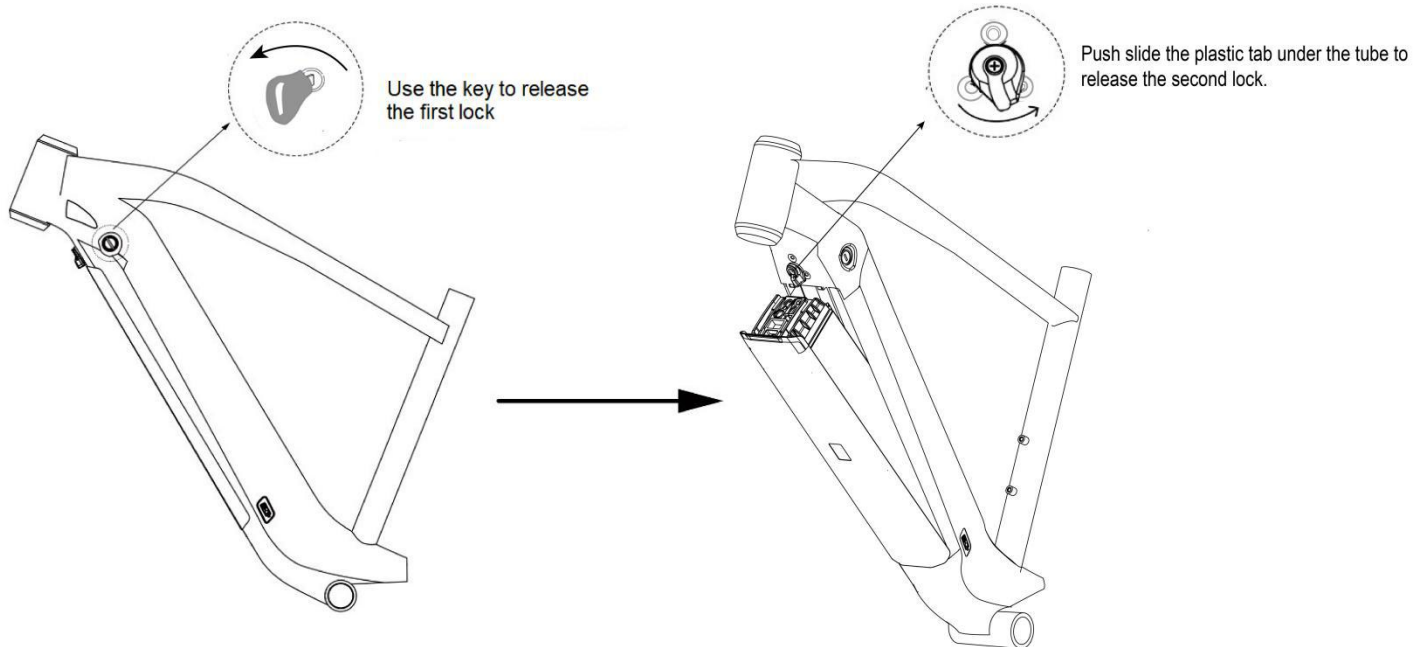

## Preparations Before Riding

- 1) **Read all instructions carefully**, be familiar with the proper operation of all items. Check for detailed information and guidance on our product page.
- 2) **Warning:** Basic electric precautions should always be followed to avoid issues or malfunction.

## How to Use the Display



### 1) Power on/off

Press the  button to turn on the display. Your bike will be **ON**. Press again to turn it off. The display will automatically shut down when there is no operation or riding for 5 minutes.

### 2) Adjust the assist level

Short press “+” or “-” button to change the assist level from 0 to 5. 0 is without assist. 5 is the max assist level.

### 3) Headlight mode

If your bike is installed with a headlight, press and hold “+” button for 1 second to switch on or switch off the headlight.



### 4) Walking mode

Press and hold “-” button for 2 seconds to shift into walking mode, the display indicates P; release the button to exit the walking mode.

### 5) Information menu

Press the  button for 1 second to shift into information menu, it will show TRIP, ODO and TIME.

### 6) Parameter setting menu

With the display powered on, if you quickly press the  button twice, it will shift into the parameter setting menu. Users are **NOT** supposed to change the factory default settings. You may exit by quickly pressing the  button twice again or leave it without operation for 30 seconds.

## How to Charge Your Bike

There are two ways to charge your battery.

### 1. Charge the battery **ON** the bike

- 1) Find the Charge Port at the bottom of the downtube.
- 2) Pull out the cover to show the charge port and insert the charger output plug into the port. Connect the input plug to the power supply.

### 2. Charge the battery **OFF** the bike

- 1) Take off the battery from your bike.
- 2) Place the battery in a clean and flat place in room temperature.
- 3) Insert the charger output plug into the charge port. Connect the input plug to the power supply.
- 4) There is a capacity indicator at the top of the battery. Press the button beside to check the charge status. Green means sufficient of charge. Yellow means less than 30%. Red means less than 10%.

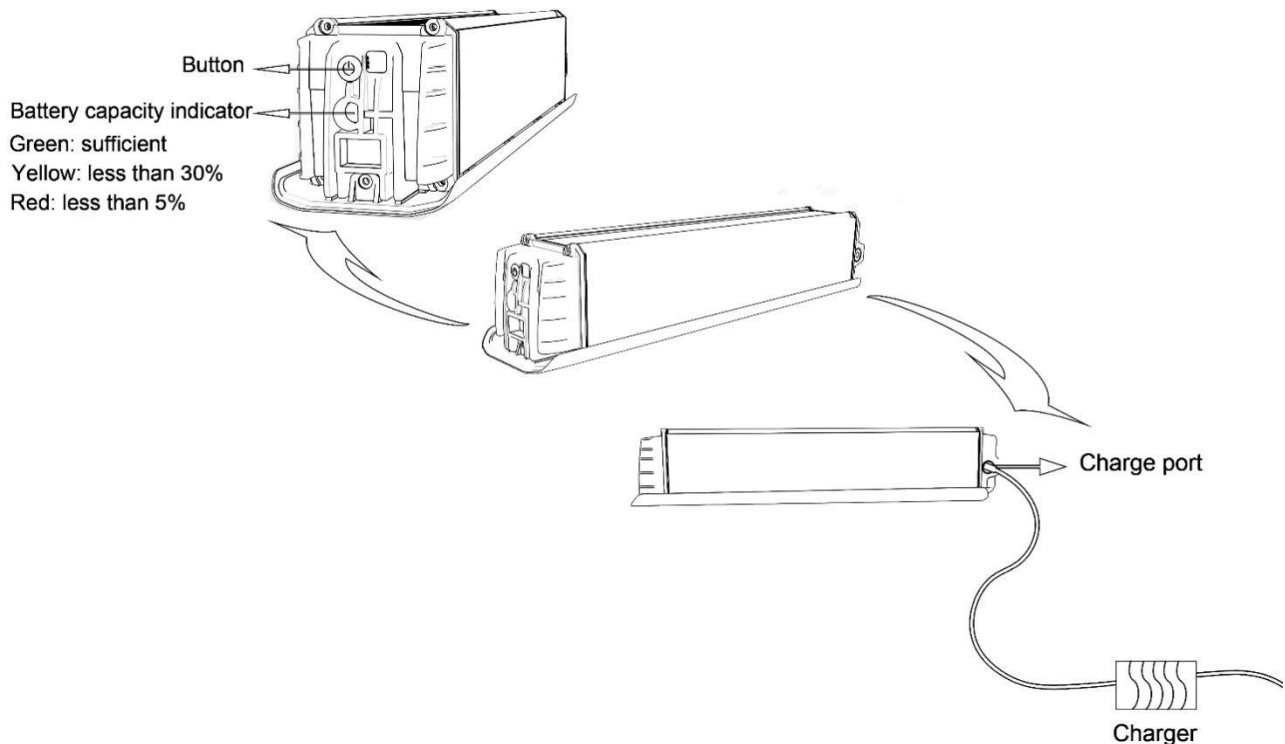

# VELOMAVE

⚠ Do not leave a charging battery unattended. Never charge a battery for more than 12 hours at a time. Failure to follow battery charging best practices could result in unnecessary wear to the charging components, battery, and or charger, and could lead to an under-performing or non-functional battery and replacement will not be covered under warranty.

## Notes of Charging:

- 1) Charging time varies from 8 to 10 hours.
- 2) The small LED light on the charger in RED indicates it is in charge; The small LED light on the charger in GREEN indicates it is fully charged.
- 3) Insufficient charging will not influence the battery lifecycle. AVOIDING deep discharge is helpful to protect the battery and extend its lifecycle.
- 4) Pay attention to check whether the surface temperature of the battery case rises too high during charging. It is FORBIDDEN to cover the battery during charging.
- 5) Due to high temperature in summer time, it is NOT advisable to charge it immediately after riding. In winter, it is FORBIDDEN to charge the battery in environment below 0°C . You are recommended to charge it in room temperature.
- 6) If the battery will not be used for a long period, take it off from the bike and discharge its capacity to 60%-80% for stock. Disconnect it from the charger and place it in a dry, ventilated place without direct sunlight. In order to maintain a long lifecycle, it is recommended to charge the battery every two months.

## Error Code

Error Code	Error	Notes
<b>4</b>	Open Throttle Fault	Throttle has not returned to the start position on start-up. Check to see if the throttle can return to the start position or if there is something blocking the throttle unit.
<b>5</b>	Throttle Fault	Throttle may be damaged. Check the throttle or throttle cable for damage.
<b>6</b>	Low Voltage Protection	The battery voltage is too low to operate. Incorrect battery was used on the bike. The battery is in sleep mode or not functioning correctly.
<b>7</b>	Over Voltage Protection	The battery voltage is too high to operate. Incorrect battery was used on the bike. Check to be sure that the correct battery is being used on the bike
<b>8</b>	Motor Hall Signal Fault	At least one of the motor's hall sensor wires have been disconnected or damaged. Disconnect and reconnect the motor cable.
<b>9</b>	Motor Phase Line Fault	At least one of the motor's phase wires has been disconnected or damaged.
<b>10</b>	High Temperature Fault	The controller has reached the highest allowable temperature. Allow the controller to cool down before using the e-bike again.
<b>12</b>	Current Sensor Fault	The controller's current sensor has become disconnected or damaged. Contact technical support.
<b>14</b>	Temperature Sensor Fault	The controller's temperature sensor has become disconnected or damaged. Contact technical support.
<b>21</b>	Speed Sensor Fault	The speed sensor has become disconnected or damaged. Contact technical support.
<b>30</b>	Communication Fault	Poor connection between the controller and the display. Check all cable connectors. Check for corrosion damage.

## Basic Trouble Shooting

<b>SYMPTOMS</b>	<b>CAUSES</b>	<b>SOLUTIONS</b>
Throttle and pedal assist not working	● Battery off	● Turn on battery
	● Battery installation	● Reseat battery
	● LCD display not on	● Turn on LCD display
	● Discharged battery	● Charge battery
	● Brake sensors engaged	● Inspect brake lever
Reduced speed	● Low battery power	● Charge battery
Reduced battery range	● Low battery power	● Charge battery
	● Low tire pressure	● Inspect tire
	● Heavy load on bike	● Adjust bike load
	● Driving on rough terrain	● Adjust route
	● Using throttle only	● Include pedal assist
Battery does not charge	● Charger not properly connected	● Inspect connections
	● Battery temperature	● Read the user manual for best practices
	● Damaged charger	● Replace charger
	● Issue with battery	● Contact Support Team
E-bike making strange noises	● Loose hardware	● Tune-up and inspection needed
	● Issue on drivetrain	● Maintenance needed
	● Issue with motor	● Contact Support Team

Label of Your RANGER

A large, empty rectangular box with a thin black border, intended for the user to provide a label for their RANGER. The box occupies most of the page's vertical space below the header.

**VELOWAVE**

To find out more, please visit our website at

***[www.velowavebikes.com](http://www.velowavebikes.com)***