

INSTRUCTION MANUAL

SM024

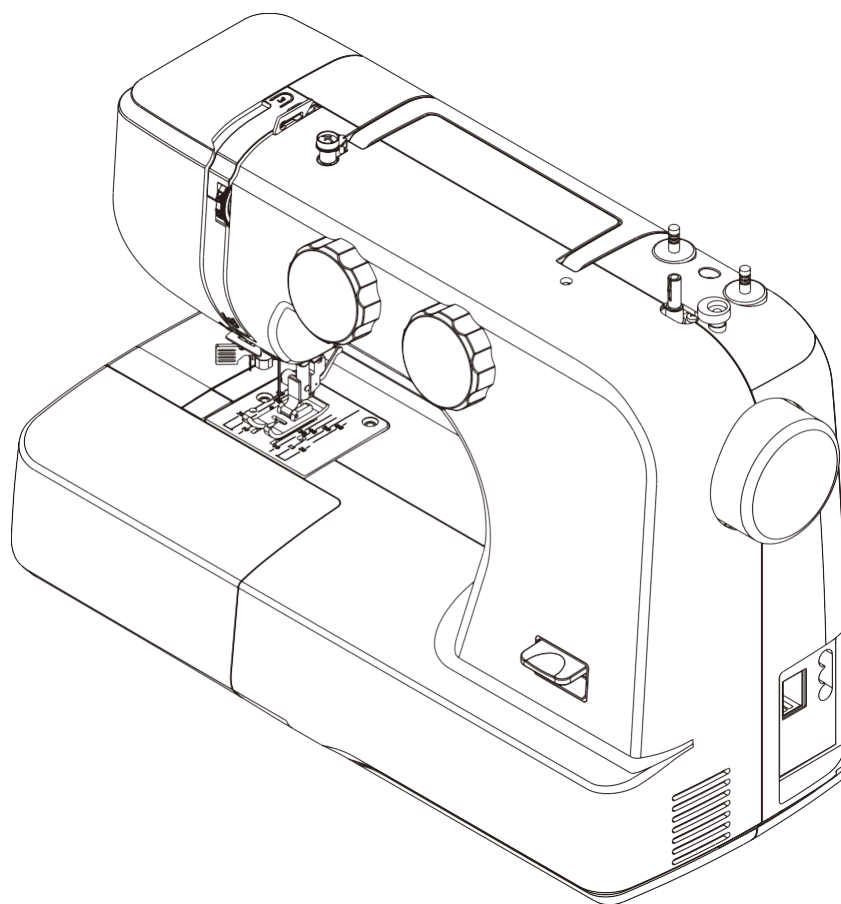

SINGER®

This household sewing machine is designed to comply with IEC/EN/CSA C22.2 No.60335-1 & 60335-2-28 and UL1594.

IMPORTANT SAFETY INSTRUCTIONS

When using an electrical appliance, basic safety precautions should always be followed, including the following: Read all instructions before using this household sewing machine. Keep the instructions at a suitable place close to the machine. Make sure to hand them over if the machine is given to a third party.

DANGER - TO REDUCE THE RISK OF ELECTRIC SHOCK:

- A sewing machine should never be left unattended when plugged in. Always unplug this sewing machine from the electric outlet immediately after using and before cleaning, removing covers, lubricating or when making any other user servicing adjustments mentioned in the instruction manual.

WARNING - TO REDUCE THE RISK OF BURNS, FIRE, ELECTRIC SHOCK, OR INJURY TO PERSON:

- Do not allow to be used as a toy. Close attention is necessary when this sewing machine is used by or near children.
- Use this sewing machine only for its intended use as described in this manual. Use only attachments recommended by the manufacturer as contained in this manual.
- Never operate this sewing machine if it has a damaged cord or plug, if it is not working properly, if it has been dropped or damaged, or dropped into water. Return the sewing machine to the nearest authorized service center for examination, repair, electrical or mechanical adjustment.
- Never operate the sewing machine with any air openings blocked. Keep ventilation openings of the sewing machine and foot control free from the accumulation of lint, dust, and loose cloth.
- Keep fingers away from all moving parts. Special care is required around the sewing machine needle.
- Always use the proper needle plate. The wrong plate can cause the needle to break.
- Do not use bent needles.
- Do not pull or push fabric while stitching. It may deflect the needle causing it to break.
- Wear safety glasses.
- Switch the sewing machine off ("0") when making any adjustment in the needle area, such as threading needle, changing needle, threading bobbin, or changing presser foot, etc.
- Never drop or insert any object into any opening.
- Do not use outdoors.
- Do not operate where aerosol (spray) products are being used or where oxygen is being administered.
- To disconnect, turn all controls to the off ("O") position, then remove plug from outlet.
- Do not unplug by pulling on cord. To unplug, grasp the plug, not the cord.
- The foot control is used to operate the machine. Avoid placing other objects on the foot control.
- Do not use the machine if it is wet.
- If the LED lamp is damaged or broken, it must be replaced by the manufacturer or its service agent or a similarly qualified person, in order to avoid a hazard.
- If the supply cord connected with the foot control is damaged, it must be replaced by the manufacturer or its service agent or a similarly qualified person, in order to avoid a hazard.

SAVE THESE INSTRUCTIONS FOR EUROPE ONLY:

This appliance can be used by children aged from 13 years and above and persons with reduced physical, sensory or mental capabilities or lack of experience and knowledge if they have been given supervision or instruction concerning use of the appliance in a safe way and understand the hazards involved. Children shall not play with the appliance. Cleaning and user maintenance shall not be made by children without supervision.

The machine must only be used with foot control of type " HKT72C" manufactured by ZHEJIANG HUAXING ELECTRIC MOTOR CO., LTD.

FOR OUTSIDE EUROPE:

This sewing machine is not intended for use by persons (including children) with reduced physical, sensory or mental capabilities, or lack of experience and knowledge, unless they have been given supervision or instruction concerning use of the sewing machine by a person responsible for their safety. Children should be supervised to ensure that they do not play with the sewing machine.

The machine must only be used with foot control of type HKT7 (110-127V Area), HKT72C (220-240V Area), HKT7-2 (220-240V China) manufactured by ZHEJIANG HUAXING ELECTRIC MOTOR CO., LTD.

INTENDED USE

Optimal use and maintenance are described in these instructions. This product is not intended for industrial use. Additional assistance, by region, may be found on the web at www.singer.com.

CONTENTS

1. KNOWING YOUR SEWING MACHINE

Main parts	2
Accessories	3
Setting up your machine	3
Power line cord, foot control	3
Power/light switch	3
Converting to free-arm sewing	4
Presser foot lifter	4
Reverse sewing lever	4
Lowering the feed teeth	4
Seam guide lines	5
Setting spool pins	5
Winding the bobbin	5
Removing or replacing the bobbin case	6
Threading the bobbin case	6
Changing the presser foot	6
Threading the machine	7
Using automatic needle threader	8
Drawing up bobbin thread	9
Balancing top thread tension	9
Needle, thread and fabric chart	10
Changing the needle	10
Pattern selector dial	11
Selecting stretch stitch patterns	11
Stitch length dial	11
Useful sewing tips	12

2. UTILITY STITCHES

Straight stitch	13
Zigzag stitch	14
Overedge stitch	14
Multi-step zigzag stitch	15
Straight stretch stitch	15
Sewing buttons	16
Buttonhole stitch	17
Zipper application	18
Blind hem stitch	19

3. DECORATIVE STITCHING

Picot hem stitch	20
Stretch stitches	20
Decorative satin stitch	21
Honeycomb stitch / smocking	21
Rampart stitch	22

4. CARING FOR YOUR MACHINE

Dismantling and assembling shuttle race	23
Cleaning the feed teeth	24
Oiling the machine	25
Oiling the connecting rod	26

5. TROUBLE SHOOTING

KNOWING YOUR SEWING MACHINE

Main parts

1. Stitch length dial
2. Pattern selector dial
3. Thread tension control dial
4. Face cover
5. Thread take-up lever
6. Thread guide
7. Bobbin winding tension disk
8. Carry handle
9. Spool pins
10. Small top cover
11. Hand wheel
12. Power cord inlet
13. Power switch
14. Reverse stitch lever
15. Front cover
16. Removable storage compartment

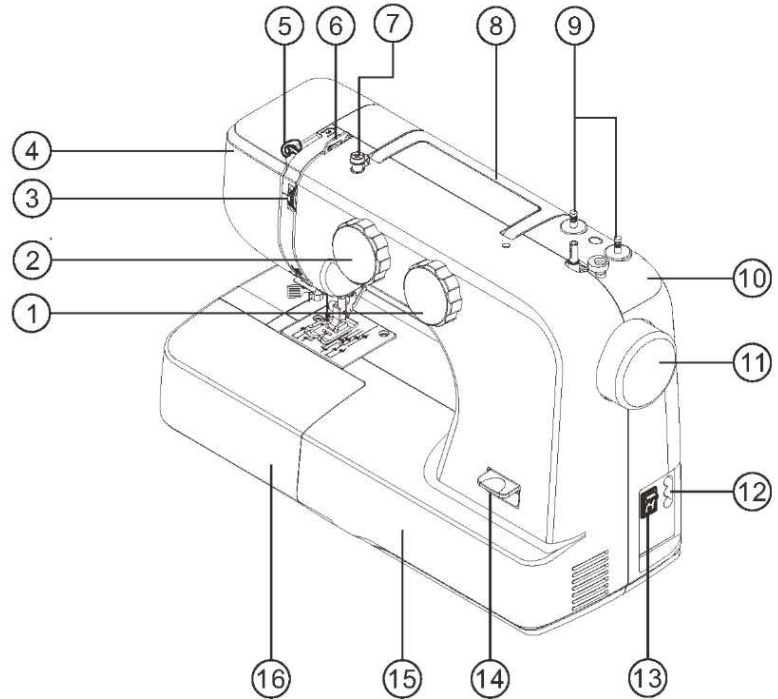

17. Bobbin winding stopper
18. Bobbin winding spindle
19. Thread knife
20. Removable storage compartment
21. Rear cover

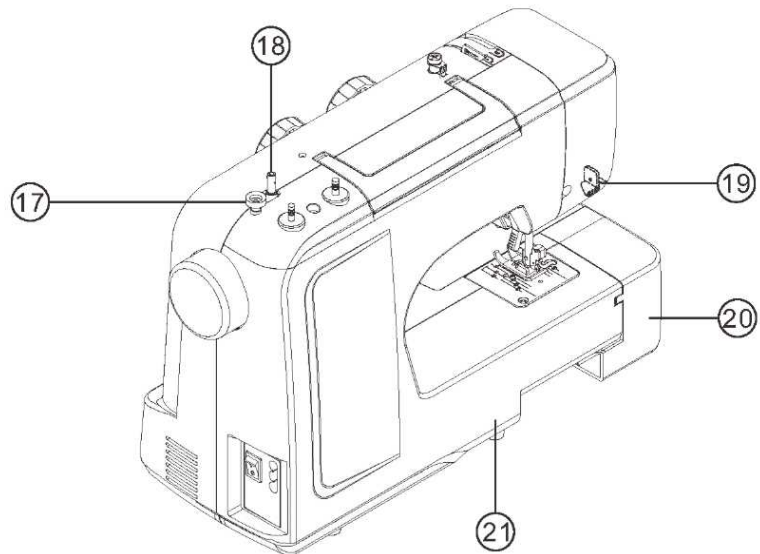

22. Automatic needle threader
23. Needle threader thread guide
24. Needle bar thread guide
25. Presser foot screw
26. Needle
27. Presser foot
28. Needle plate
29. Feed teeth
30. Presser foot holder
31. Needle clamp screw
32. Press foot lifter

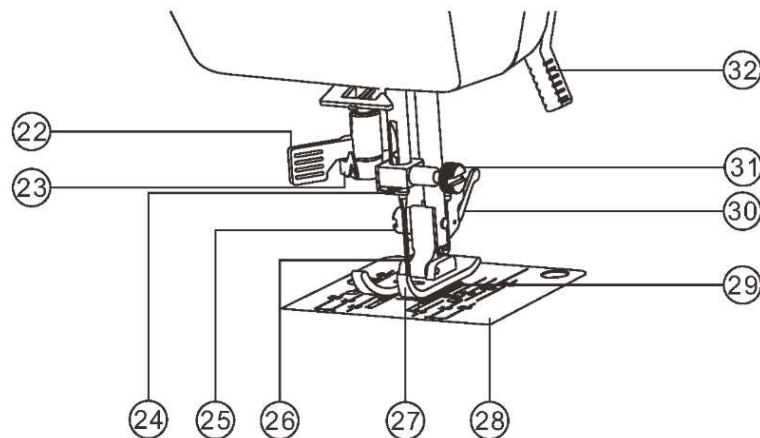

KNOWING YOUR SEWING MACHINE

Accessories

1. Bobbins (3pcs) *
2. Needle 3 pcs
3. Multi-function screwdriver
4. Ripper/Brush
5. Buttonhole foot
6. Hem guide for presser foot
7. Zipper foot
8. Button sewing foot

***Your machine uses SINGER® Class 15J transparent bobbins. Use only this style of bobbin in your machine.**

The foot that comes on your sewing machine is called all-purpose foot and will be used for the majority of your sewing.

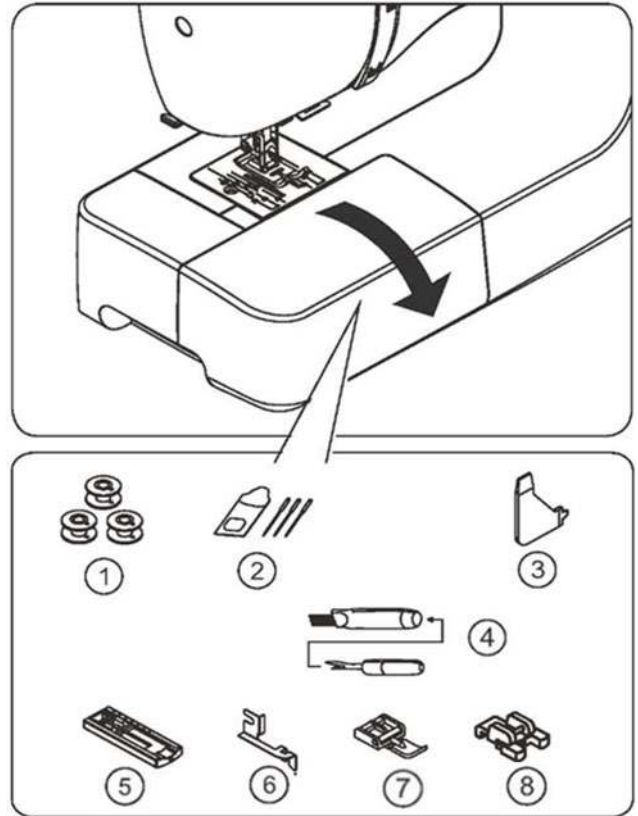

Setting up your machine

Be sure to wipe off any surplus oil from needle plate area before using your machine the first time.

Power line cord, foot control

Make sure that the sewing machine is turned off (the power switch is set to “O”), and then connect the plug of the power line and into the power cord inlet and your wall outlet.

Sewing speed can be varied with the foot control.
The harder you press on the control, the faster machine runs.

This appliance has a polarized plug (one blade wider than the other). To reduce the risk of electric shock, this plug is intended to fit in a polarized outlet only one way. If the plug does not fit fully in the outlet, reverse the plug. If it still does not fit, contact a qualified electrician to install the proper outlet. Do not modify the plug in any way.

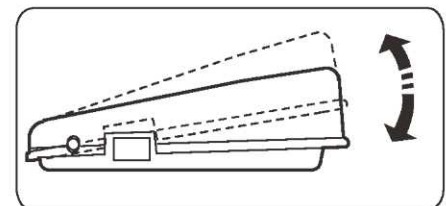
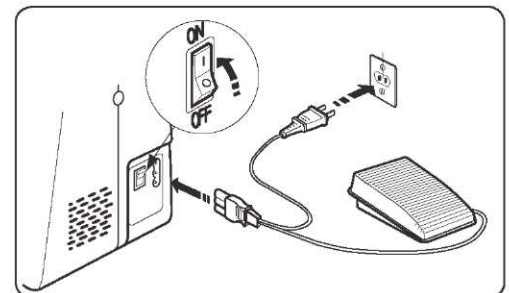

NOTE: When foot control is disconnected, the machine will not operate.



Always disconnect the machine from power supply by removing the plug from the wall-outlet.



Power/light switch “OFF”

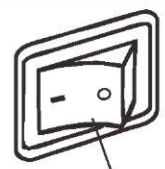

Power/light switch “ON”

Power/light switch

Your machine will not operate until the power/light switch is turned on. The same switch controls both the power and the light. When servicing the machine or changing needles, etc., machine must be disconnected from the power supply.

KNOWING YOUR SEWING MACHINE

Converting to free-arm sewing

Your machine can be used either as a flat-bed or as a free-arm model. With the removable storage compartment in position, it provides a large working surface as a standard flat-bed model. To take off the removable storage compartment, hold it firmly with both hands and pull it off to the left as shown. To replace, slide the removable storage compartment back into place until it clicks.

With the removable storage compartment off, the machine converts into a slim free-arm model for sewing children's clothing, sleeve cuffs, trouser legs, and other hard-to-reach places.

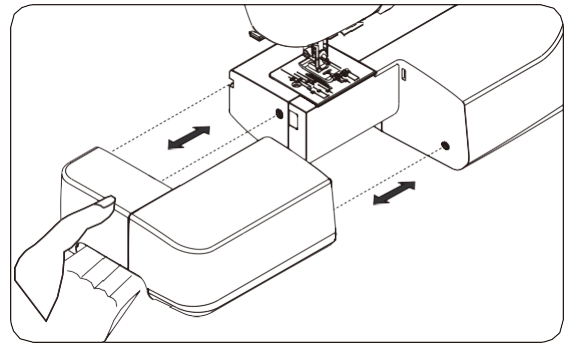

Presser foot lifter

There are three positions for your presser foot.

1. Lower the presser foot to sew.
2. Raise the lifter to the middle position to insert or remove fabric.
3. Lift it to its highest position to change the presser foot or to insert or remove thick fabrics.

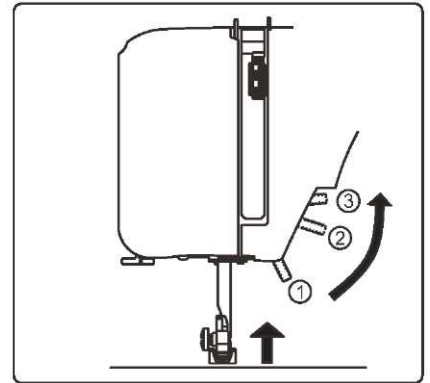

Reverse sewing lever

As long as you are pressing down this lever while sewing, the machine will feed the fabric backwards.

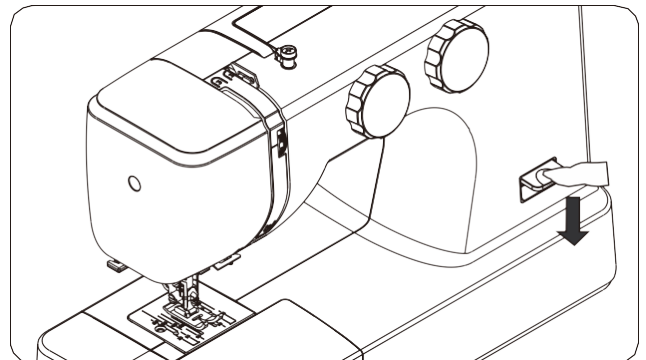

Lowering the feed teeth

1. For lowering the feed teeth, press down lever and move it to the direction of arrow as illustrated.
2. To raise the feed teeth, press down the lever and move it to the direction of arrow as illustrated. After moving the lever, turn the hand wheel toward you one full revolution to completely re-engage the feed teeth.

* **Feed teeth must always be up for normal sewing.**

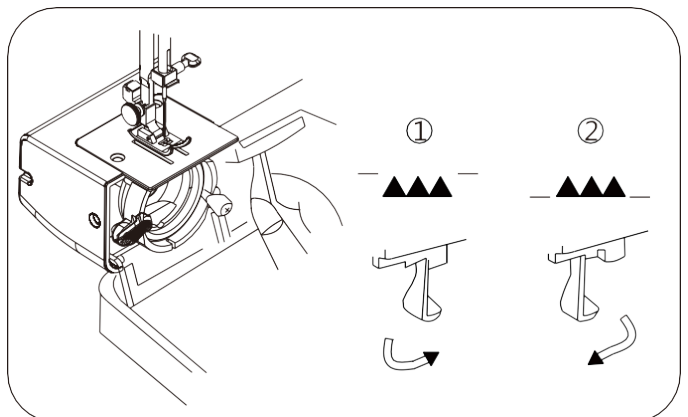

KNOWING YOUR SEWING MACHINE

Seam guide lines

The numbers on the needle plate indicate the distance between the center needle position and the various seam guide lines.

The numbers in the front indicate in millimeters.

The numbers in the back indicate in inches.

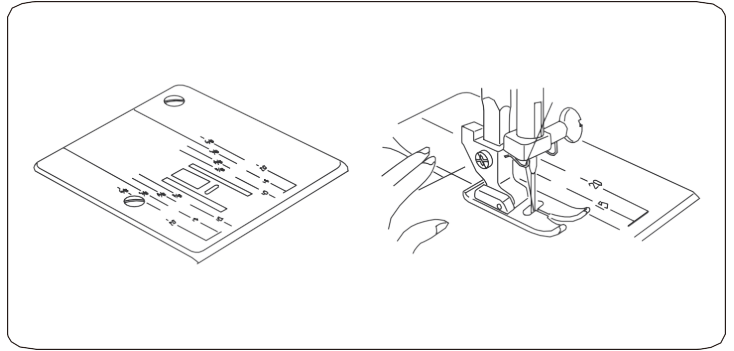

Setting spool pins

The spool pins are used for holding the spool of thread in order to feed thread to the machine.

To use, pull up the spool pin. Push down for storage.

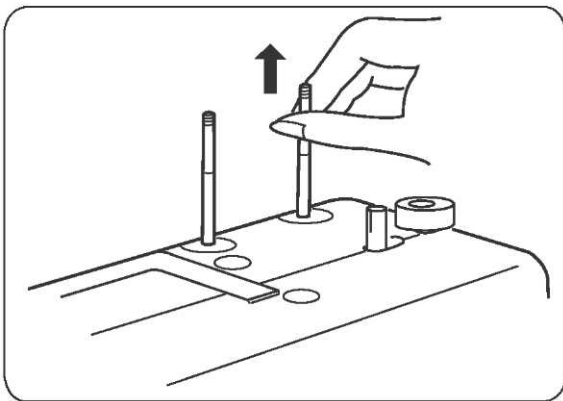

Winding the bobbin

1. Place a spool of thread on the left spool pin. Pull the thread out from the spool and place it through thread guide as shown in illustration. Put end of thread through the hole in bobbin as shown.
2. Push the bobbin winding spindle to far left position, if it is not already there. Place bobbin onto the bobbin winding spindle with end of thread coming from top of bobbin. Push bobbin winding spindle to the right until it clicks. Hold onto end of thread.
3. Start machine. Bobbin will automatically stop turning when completely filled. Push bobbin winding spindle to the left to remove bobbin and cut thread.

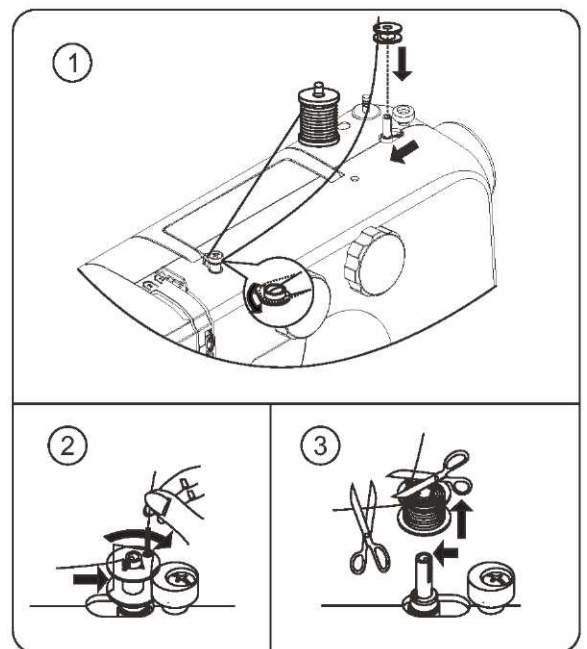

KNOWING YOUR SEWING MACHINE

Removing or replace the bobbin case

1. Refer to page 4 to take off the removable storage compartment. Raise the needle by turning the hand wheel toward you, then open the shuttle cover.
2. Take out bobbin case holding the latch.
3. When installing the bobbin case, the pin on the case should fit into the gap of the shuttle race.



CAUTION

Be sure to disconnect the power supply before operating the machine.

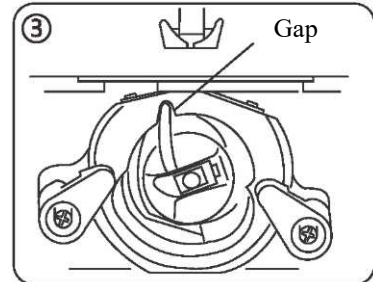
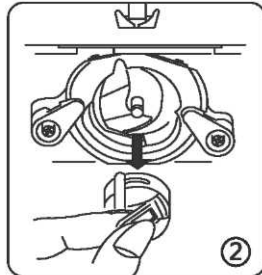
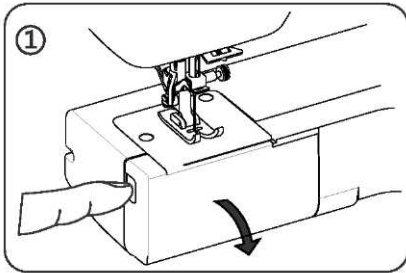

Threading the bobbin case

1. Install the bobbin into bobbin case. Make sure the thread unwinds in the direction of arrow (clockwise).
2. Pull the thread into the groove in the bobbin case slot.
3. Now pull the thread under the tension spring and into the delivery eye.

NOTE: Leave about 10cm (4 inches) of the thread hanging out of the bobbin case. When you pull the thread, the bobbin should spin clockwise.

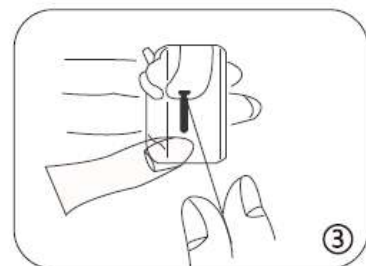
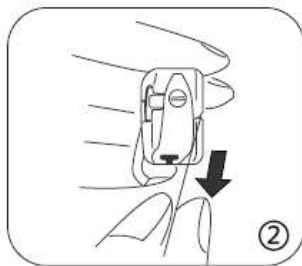

Changing the presser foot

1. Turn the hand wheel toward you to raise the needle to its highest position. Raise the presser foot.
 2. Press the lever on the back of the presser foot holder. The presser foot will drop off.
 3. Place the presser foot so the pin on the foot lies just under the groove of the holder.
- Lower the presser foot holder to lock the foot in place.

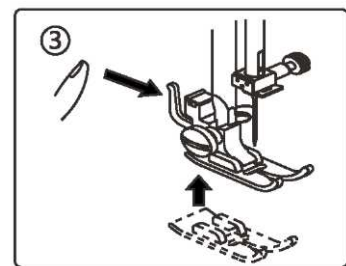
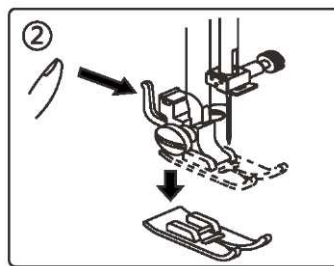
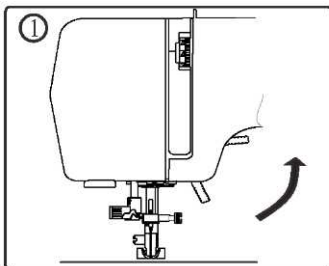

KNOWING YOUR SEWING MACHINE

Threading the machine

Raise take-up lever to its highest position by turning hand wheel toward you.

Raise the presser foot. It is very important to raise the presser foot before you begin threading, or correct thread tension cannot be obtained.

Place spool on spool pin as shown, with thread coming from the back of the spool.

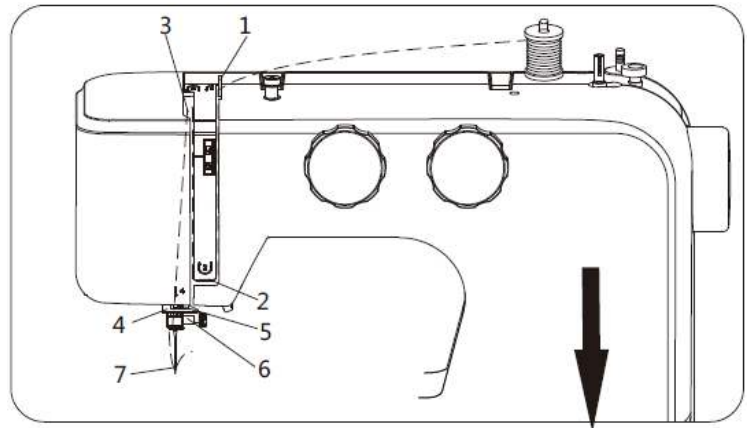

1. Draw thread into thread guide using both hands.
2. Draw the thread down into the tension area and around the U-turn.
3. Firmly draw thread up and through take-up lever from right to left.
4. Then draw thread down and slip it into the lower thread guide.
5. Do not block the thread into double needle spring.
6. Draw thread down and slip it into needle bar thread guide.
7. Thread needle eye from front to back.

Note: Cut the thread end with sharp scissors for easier needle threading.

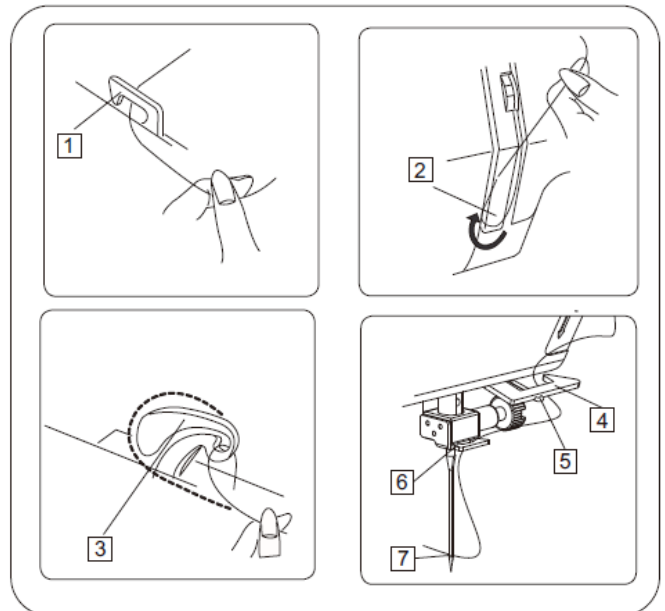

KNOWING YOUR SEWING MACHINE

Using automatic needle threader

Raise the needle to its highest position by rotating the hand wheel towards you.

1. Hook thread to thread guide, as illustrated.
2. Pull down the lever while holding the end of thread.
3. Rotate the lever to the rear of the machine until the hook pin comes through the eye of the needle.
4. Guide thread into hook pin, in front of the needle, and lightly pull the thread upward.
5. Return the lever and needle will be threaded automatically, forming a small loop.
6. Release the lever and pull thread away from you until the thread tail is completely threaded.

NOTE: For smooth threading it is recommended you select straight stitching when using the needle threader.

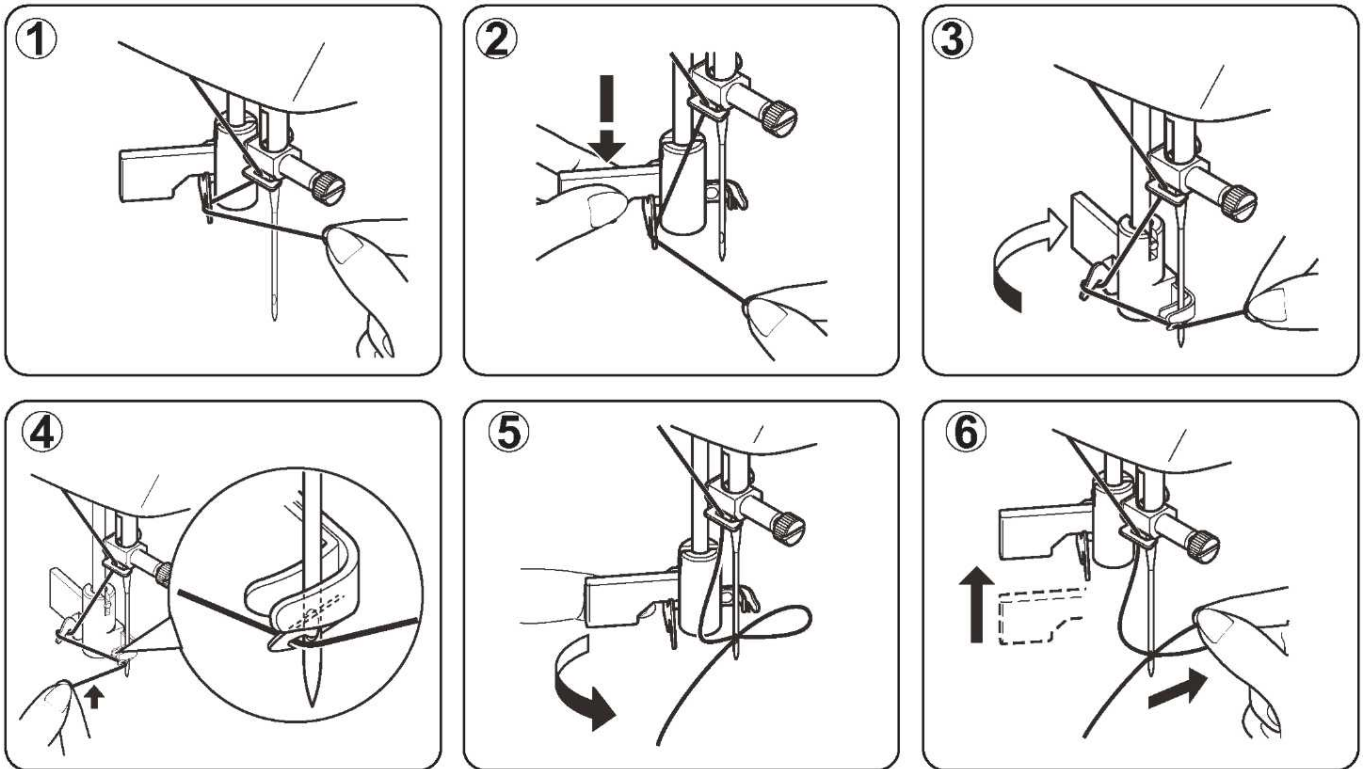

NOTE: Automatic needle threader is only applicable for all-purpose presser foot. Automatic needle threader cannot be used for twin needles.

KNOWING YOUR SEWING MACHINE

Drawing up bobbin thread

- ① Raise the presser foot and hold the needle thread lightly with your left hand.
- ② Turn the hand wheel slowly towards you with your right hand until the needle goes down and continue turning the hand wheel until the take-up lever is at its highest position.
Lightly draw up the needle thread, forming a loop of the bobbin thread.
- ③ Pull 15cm (6 inches) of both threads back and under the presser foot.

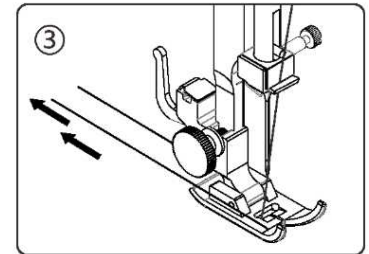
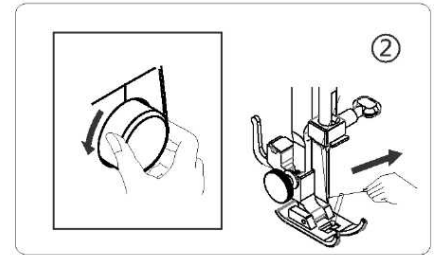
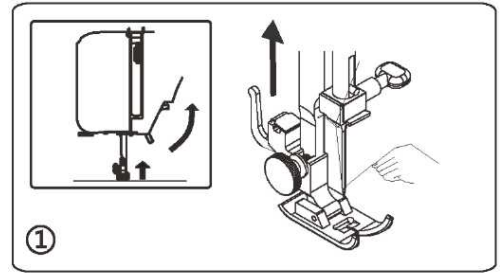

Balancing top thread tension

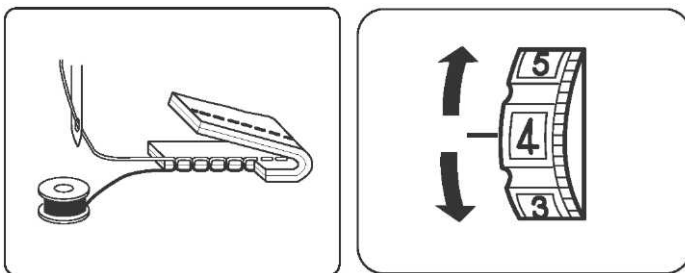

The top thread and the bobbin thread should interlock in the center of two layers of fabric in straight seams. Set the desired number of the thread tension dial at setting mark.

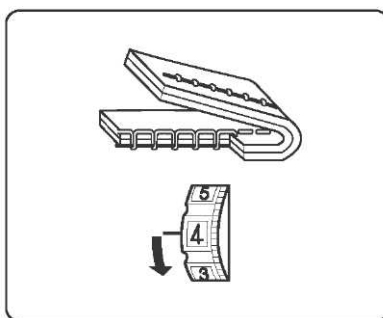

Tighten the needle thread tension by moving the dial to a higher number.

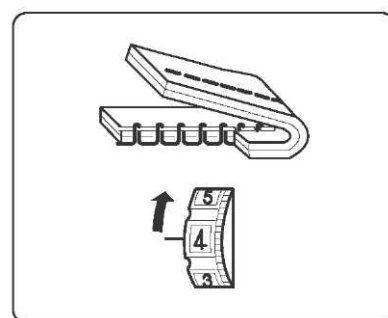

Loosen the needle thread tension by moving the dial to a lower number.

NOTE: In order to obtain better zigzag stitches, the top thread tension should be slightly looser than the bobbin thread tension. That means the top thread should appear slightly on the reverse side of the fabric, but the bobbin thread should not appear on the top side of the fabric.

KNOWING YOUR SEWING MACHINE

Needle, thread and fabric chart

Your fabric will determine the choice of a needle and thread. The following table is a practical guide to needle and thread selection.

Always refer to it before a new sewing project. And be sure to use the same size and type of thread in the bobbin as in the top thread supply.

Kind	Fabric	Threads	Needle size
Light Weight	Voile, Organza, Organdy, Chiffon, Tricot	Fine Silk, Fine Cotton, Fine Polyester	9 or 12
Medium Weight	Linen, Cotton, Rayon, Wool Double Knit	Cotton, Polyester, All-Purpose	12 or 14
Heavy Weight	Denim, Tweed, Gabardine, Canvas, Upholstery Fabric	Polyester, All-Purpose, Topstitching	14 or 16



CAUTION

Always disconnect the machine from power supply by removing the plug from the wall-outlet.

Changing the needle

1. Raise the needle by turning hand wheel toward you and lower the presser foot.
2. Rotate the needle clamp screw toward you (counter-clockwise) to loosen the needle.
3. Remove the needle from the clamp.
4. Insert the new needle into the needle clamp with the flat side away from you.
5. When inserting the needle into the clamp, push it up as far as it will go.
6. Tighten the clamp screw clockwise firmly with the screwdriver.

NOTE: Tighten snugly, but do not over tighten.

Helpful Hint: Placing a scrap of fabric under the presser foot and lowering the presser foot makes it easier to change the needle and will preclude dropping the needle into the needle plate slot.



Change the needle often. As a general rule, needles, should be changed every 6-8 hours of actual stitching time.

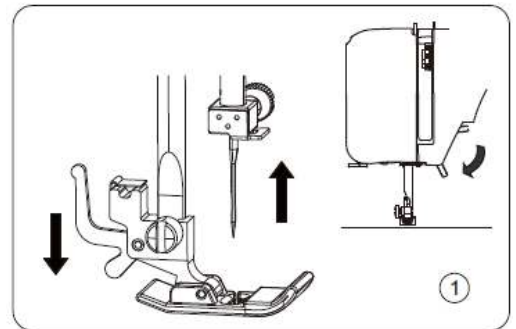

* Check your needles frequently for barbed or blunted points. Snags and runs in knits, fine silks and silk-like fabrics are permanent and are almost always caused by damaged needle.

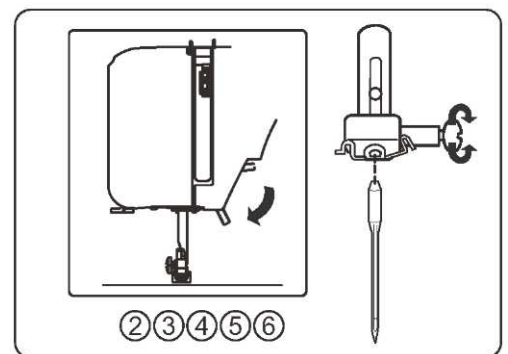

KNOWING YOUR SEWING MACHINE

Pattern selector dial

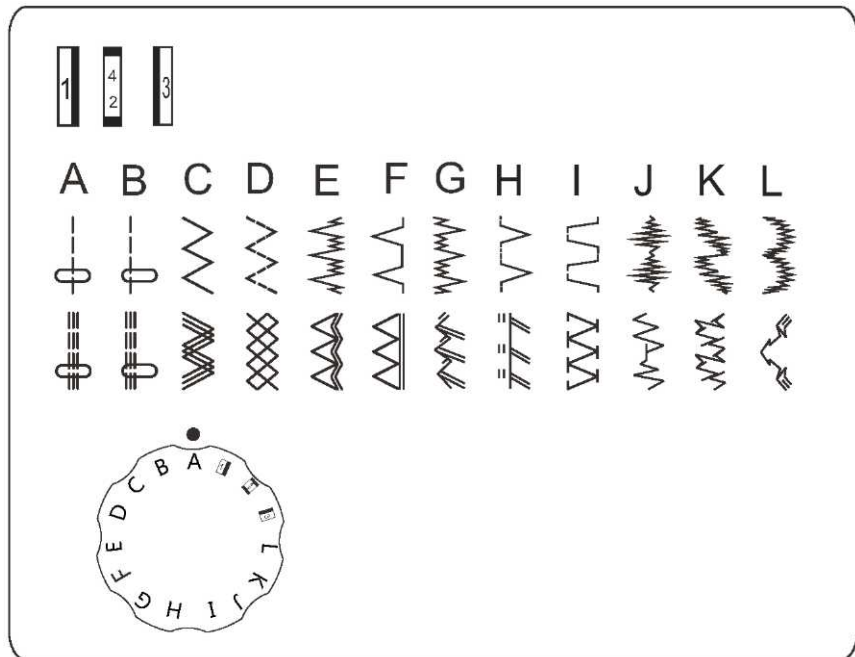

Select the desired pattern at the setting mark by turning the pattern selector dial.

Selecting stretch stitch patterns

When sewing stretch stitches, set the stitch length dial at "SS".

When forward and reverse feeds become unbalanced depending upon the type of fabric, correct as follows.

When patterns are compressed, correct it by turning the dial toward "+".

When patterns are drawn out, correct it by turning the dial toward "-".

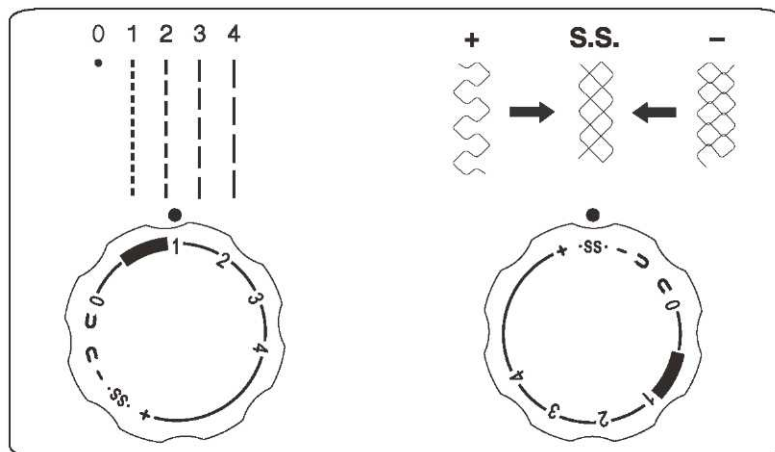

Stitch length dial

The higher the number, the longer the stitch length. Note: when set to "0", the machine will not feed the fabric.

KNOWING YOUR SEWING MACHINE

Useful sewing tips

Various ways to achieve better sewing results are described below. Refer to these tips when sewing.

1. Trial sewing

Use different stitch width and length for trial sewing. When you have finished, select the best looking stitch length for correct sewing.

For the trial sewing, use a piece of fabric and thread that are the same as those used for your project, and check the thread tension and stitch length. Since the results differ depending on the type of stitching and the number of fabric layers sewn, perform the trial sewing under the same conditions that will be used with your project.

2. Changing the sewing direction

Stop the machine and turn the hand wheel toward you to bring the needle down into the fabric. Raise the presser foot.

Pivot the fabric around the needle to change sewing direction as desired. Lower the presser foot and continue sewing.

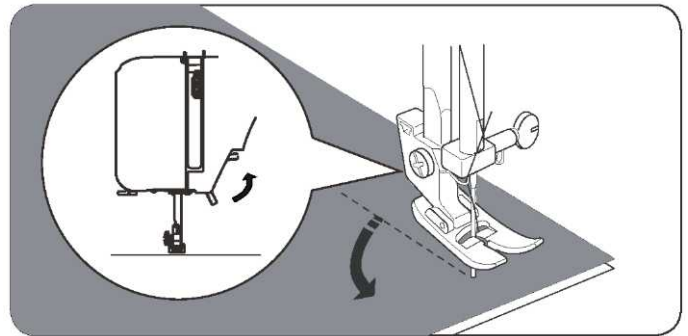

3. Sewing curves

- 1). Stop sewing, and then slightly change the sewing direction to sew around the curve.
- 2). When sewing along a curve while using a zigzag stitch, select a shorter length in order to obtain a finer stitch.

4. Sewing thick fabrics

If the fabric does not fit under the presser foot

Raise the presser foot even higher to bring the presser foot to its highest position. Then place the fabric under the presser foot. (See page 4 to raise the presser foot.)

5. Sewing elastic fabric or the fabric that is easy to cause skipping stitches

Use ball point needle and longer stitch length. If necessary, add a layer of stabilizer under the fabric for better sewing.

6. Sewing thin fabric or silk

Some fine fabrics, such as silk, can be slippery and more difficult to handle. It can be helpful to place a lightweight stabilizer underneath the fabric for easier sewing.

7. Sewing stretch fabrics

First, baste the fabrics together, and then sew without stretching the fabric.

8. Free arm sewing

When sewing trousers, sleeve cuffs or other hard-to-reach areas, use the free-arm sewing function (for details about setting the machine for free-arm sewing, refer to page 4).

UTILITY STITCHES

Straight stitch

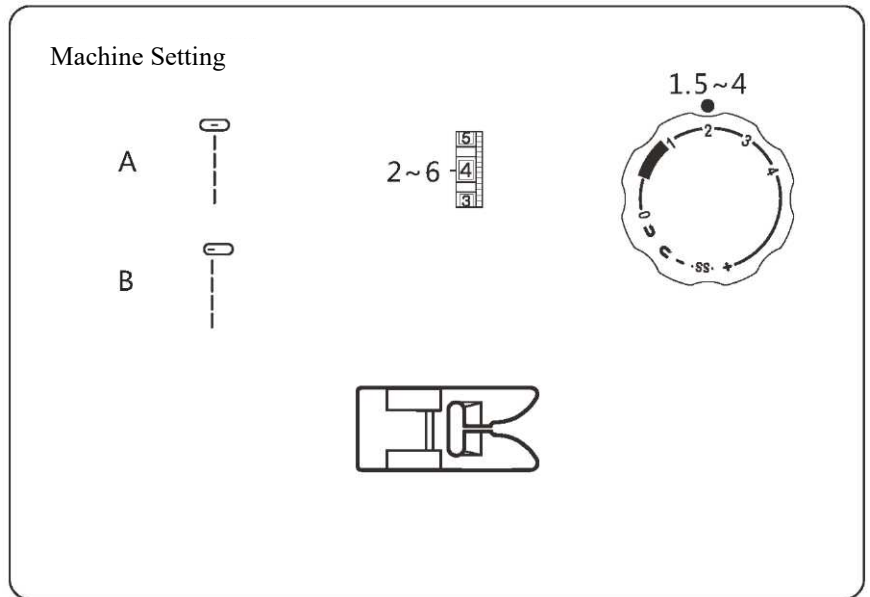

Raise the presser foot and position the fabric next to a stitching guide line on the needle plate.

Lower the needle into the fabric.

Lower the presser foot and smooth the thread towards the back. Depress the foot control.

Gently guide the fabric along the guide line letting the fabric feed by itself.

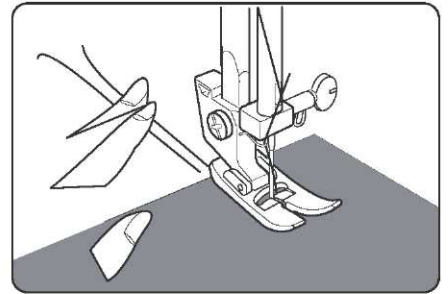

For securing the ends of seams, press the reverse stitch lever and sew several reverse stitches.

Raise the presser foot and remove the fabric, drawing the threads to back.

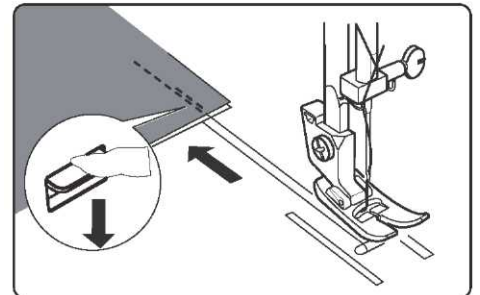

The threads are cut the proper length for starting the next seam.

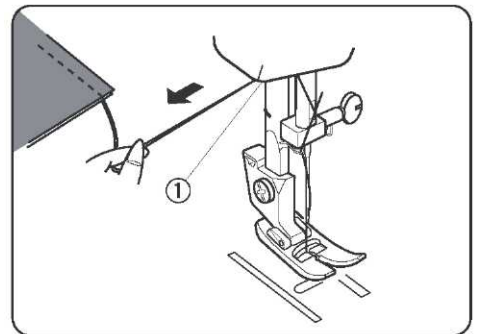

UTILITY STITCHES

Zigzag stitch

Simple zigzag stitching is widely used for overcasting, sewing on buttons, decorative stitching, etc.

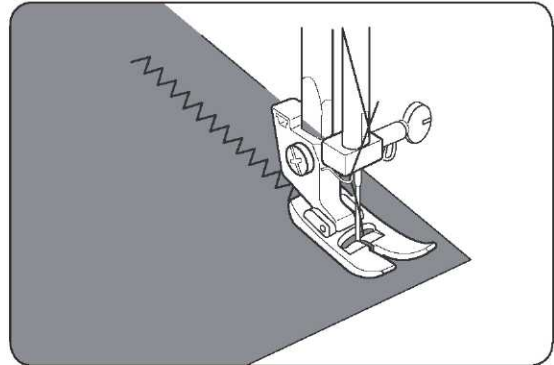
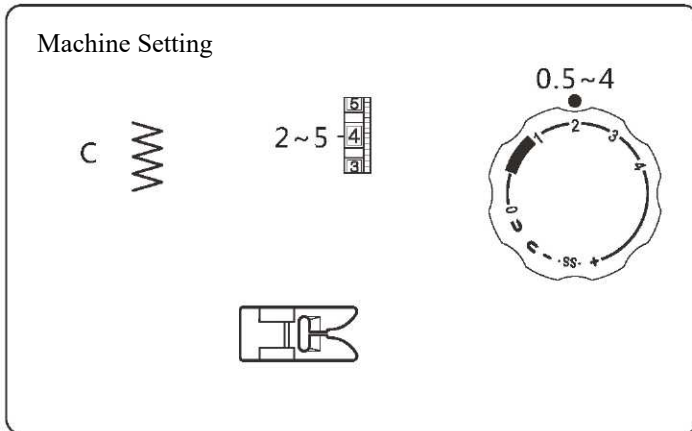

The zigzag stitch can also be used on the seam allowance to prevent fabrics from fraying at raw edges.

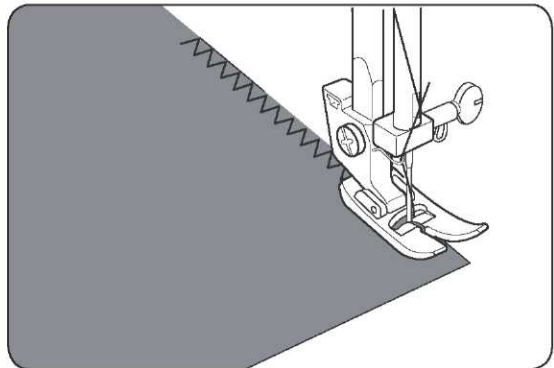
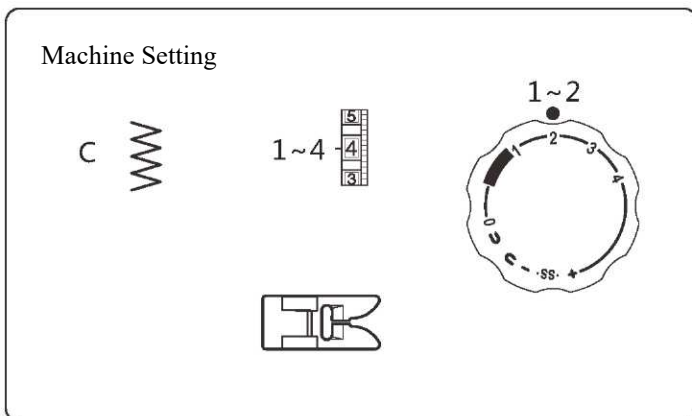

Overedge stitch

Overedge stitch will be done most successfully when the right side stitches of zigzag fall slightly off the edge of the fabric.

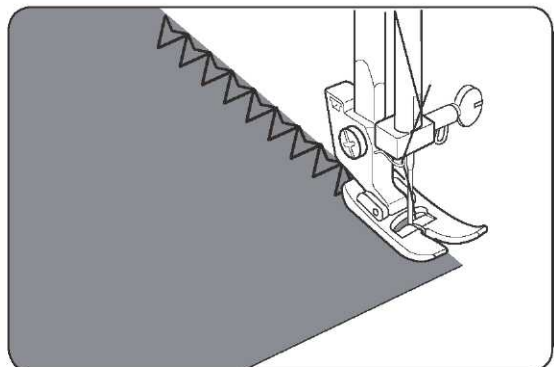
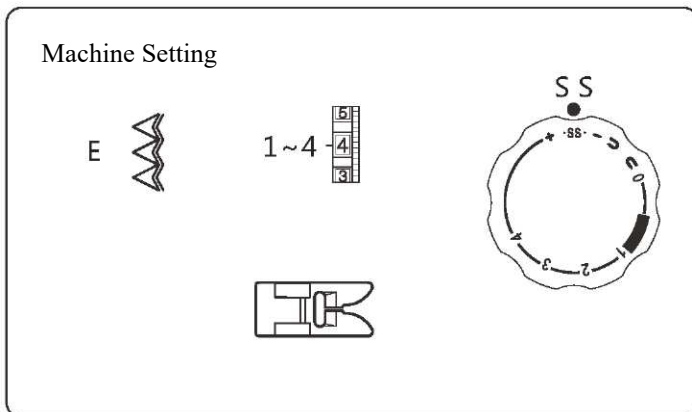

UTILITY STITCHES

Multi-step zigzag stitch

To help prevent fabrics from unraveling, place the fabric under the presser foot so the right-hand side of the stitches falls at the edge of the fabric.

This stitch can also be used for elastic insertion, decorative stitching, and more.

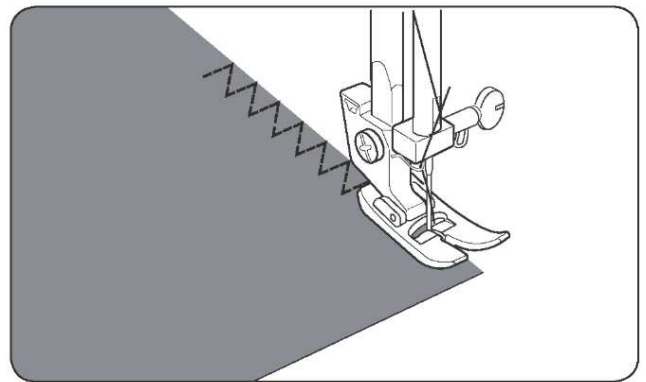
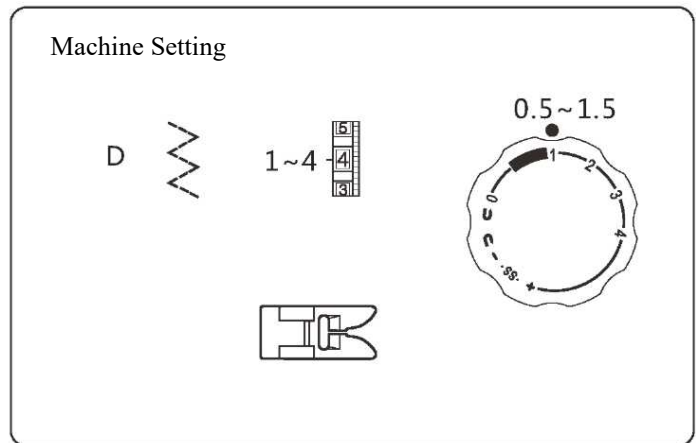

Straight stretch stitch

The stitch is sewn with two stitches forward and one stitch backward forming a seam that does not rip easily.

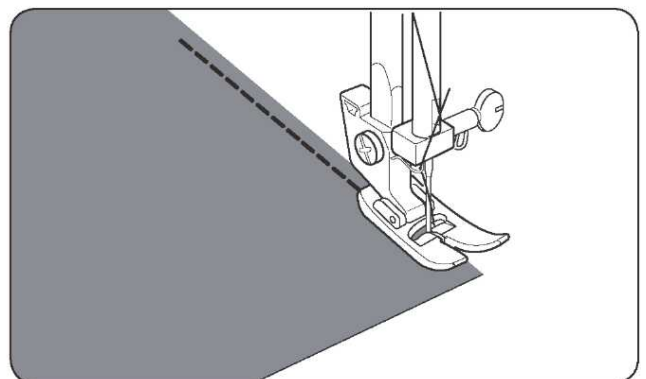
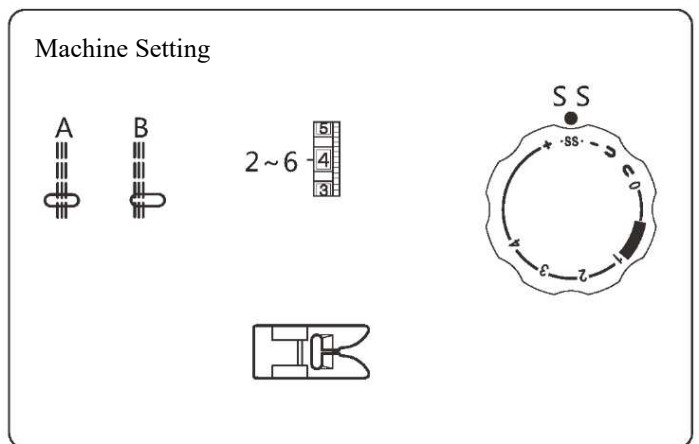

UTILITY STITCHES

Sewing buttons

Machine Setting

C~B



1~3



—▲▲▲— Lower the feed teeth

NOTE: 1. Lower the feed teeth (refer to page 4).
After you finish sewing, set drop feed lever to original position, and turn the handwheel one full turn to re-engage feed teeth.

2. You do not have to adjust the stitch length dial.

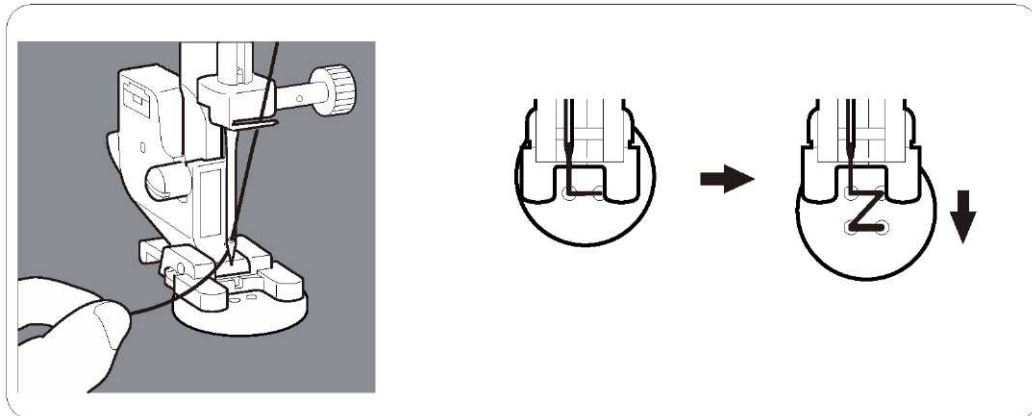

Position your fabric and button under the presser foot. Lower presser foot. Turn the handwheel to make sure needle clears both left and right openings of button. Sew 10 stitches across.

When attaching four-hole buttons, first sew the two holes closest to you. Then, slide the button so that the needle goes into the two holes toward the rear of the sewing machine, and then sew them in the same way.

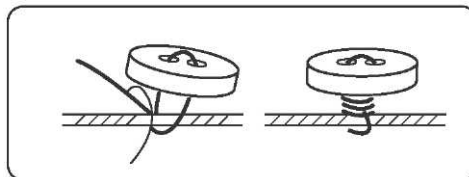

To secure thread, cut the upper thread with 25cm of excess, wind it around the thread between the button and the fabric, and then tie it securely.

UTILITY STITCHES

Buttonhole stitch

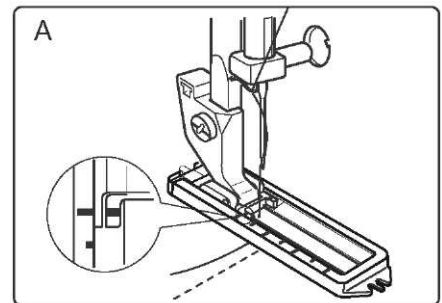
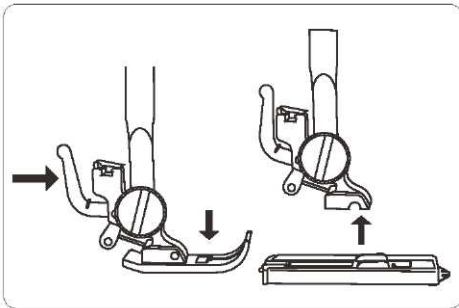
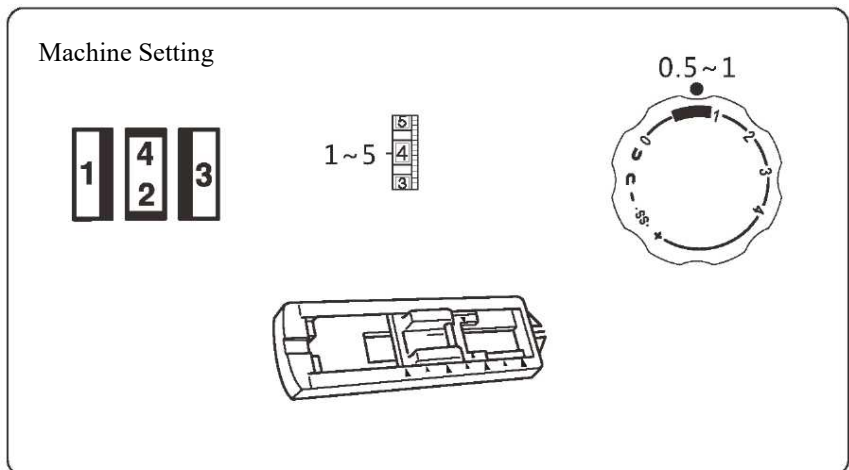



Replace the buttonhole foot.

- * Before you sew the actual buttonholes on the actual garment, make several practice buttonholes on a fabric sample.
- * Use interfacing to help prevent fabric from puckering.

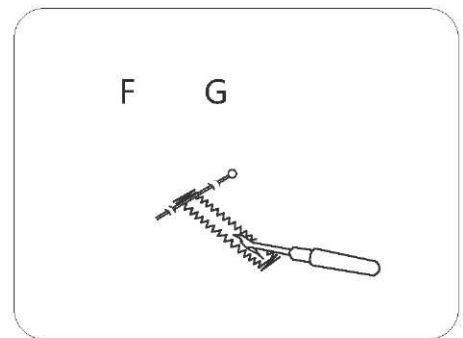
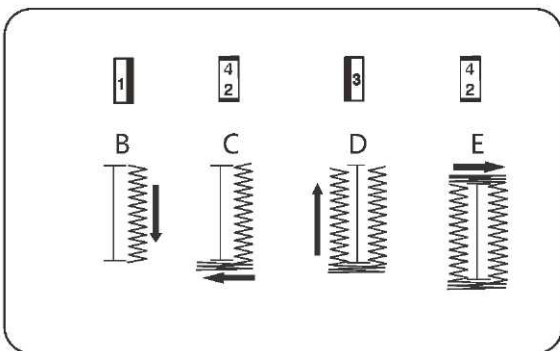
- A. Select , draw both thread to the left under the foot.
Insert the garment under the foot.



- B. Lower the needle at the starting point. then lower buttonhole foot. Sew the needed length on the right side of buttonhole and stop the machine.
- C. Raise the needle to its highest position by turning the hand wheel toward you, then select . Sew 5-6 bartack stitches at the bottom of the buttonhole.
- D. Raise the needle to its highest position and select , sew the left side of buttonhole the same length as the right side and stop the machine.
- E. Raise the needle by turning the handwheel and select . Sew 5-6 bartack stitches at the top of the buttonhole.
- F. Raise the presser foot and draw out the fabric. Cut both top thread and bobbin thread leaving about 10 cm of thread ends. Use a hand sewing needle to bring the upper thread to the back side of the garment. Tie threads on the wrong side of the fabric to secure.
- G. Cut open the buttonhole with seam ripper.

UTILITY STITCHES

Buttonhole stitch

Tips:

Slightly reduce the upper tension for best results.

Use stabilizer for fine or stretchy materials.

We recommend placing a pin across the end of the buttonhole as a precaution against cutting the stitches with the seam ripper.

It is advisable to use gimp cord for stretch or knit fabrics. The zigzag should sew over the gimp.

The lines on the buttonhole foot can be used guides when sewing multiple buttonholes.

1. Lift the presser foot, pull the gimp cord and come round the protruding point on back of the buttonhole foot.
2. Pull the gimp cord under the foot to the front.
3. Fix the gimp cord to the protruding point on front of foot.
4. Turn the needle down to the starting position on fabric, put down the presser foot.
5. Sew the buttonhole according to page 17.
6. Pull the gimp cord straightly.
7. Cut the gimp cord.

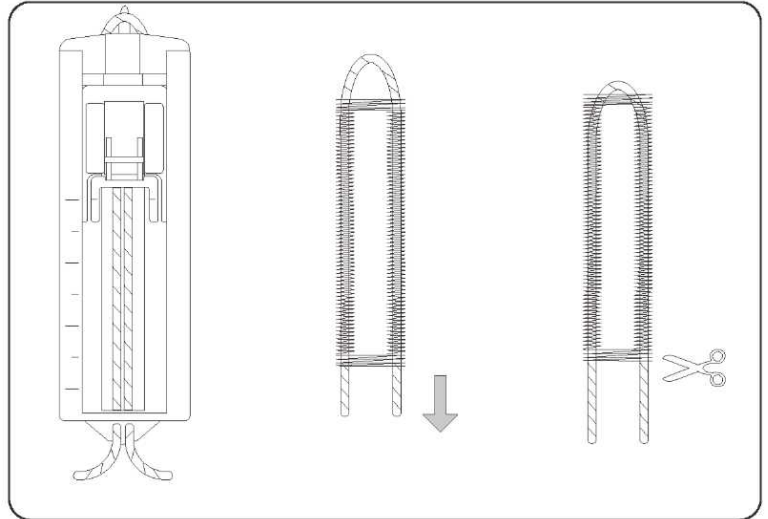

Zipper application

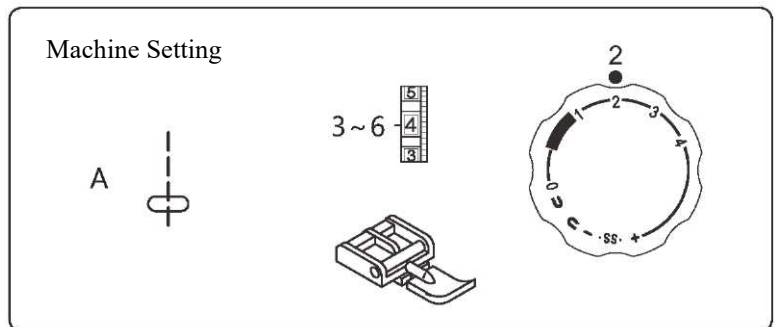

Attach the zipper foot.

When sewing the right side of the zipper, attach the zipper foot as the illustration in right.

When sewing the left side of the zipper, attach the zipper foot as the illustration in right.

Sew the right side of the zipper.

Sew the left side of the zipper.

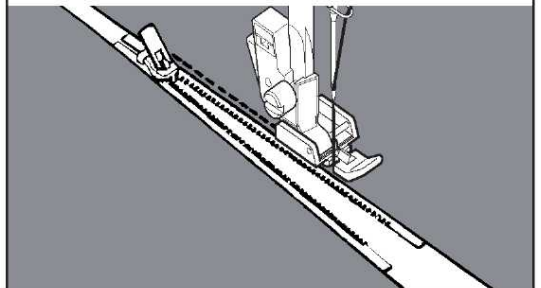

Helpful hint:

During zipper inserting, ensure that the needle does not touch the zipper coil. Otherwise, it may cause the needle break or even cause injury.

UTILITY STITCHES

Blind stitch

Stitch E is for hems on stretch knit fabrics.

Stitch F is for hems on woven (non-stretch) fabrics.

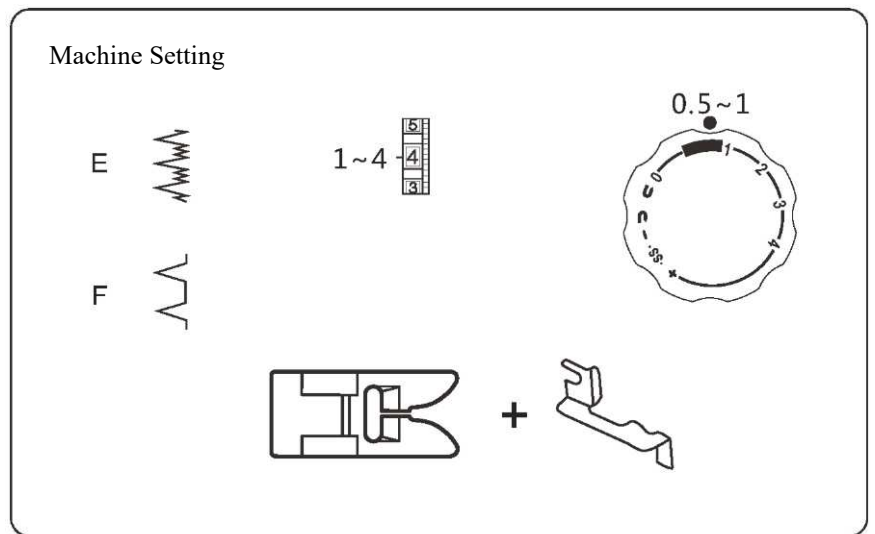

Fold up the fabric as illustrated.

Lower the presser foot, then loosen the foot holder screw to place the hem guide between the screw and the shank of foot holder.

Tighten the screw making sure the front wall of hem guide is placed between the toes of the presser foot.

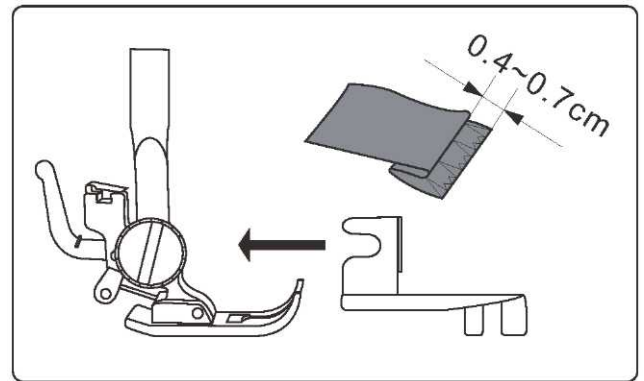

Raise the presser foot and place the fabric under the foot so that the soft fold rests against the front wall of the hem guide.

Lower the foot, then stitch slowly for better control so that the zigzag stitches fall on the hem allowance and pierce the soft fold.

While sewing, make sure the soft fold runs along the front wall of the hem guide.

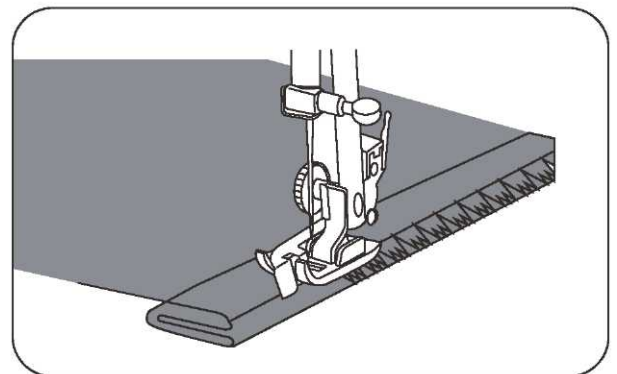

Spread the fabric flat with the right side facing up.

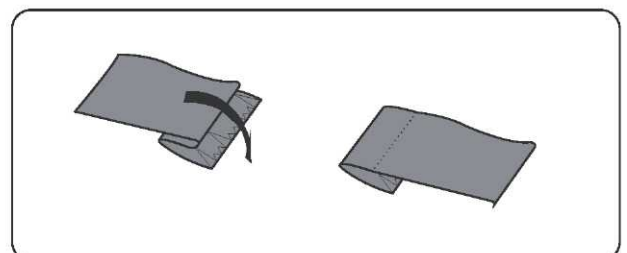

DECORATIVE STITCHING

Picot hem stitch

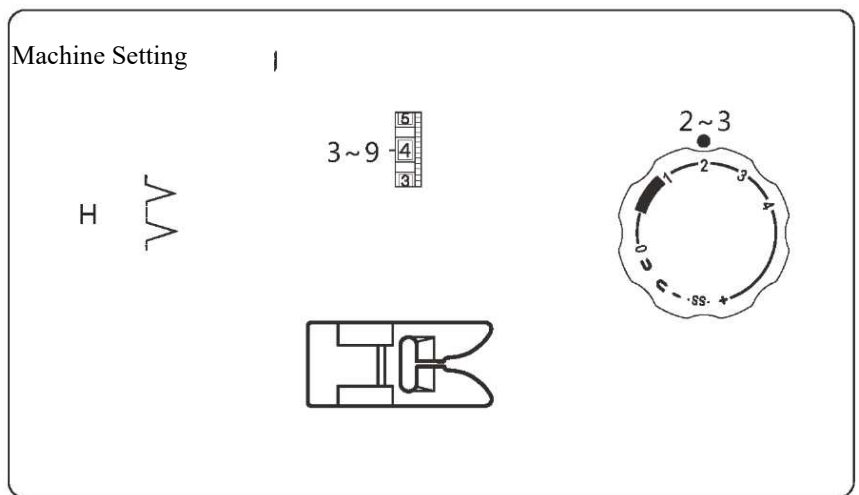

Place the folded edge along the slot of foot. The needle should fall off the edge of the fabric on the right, forming a tuck.

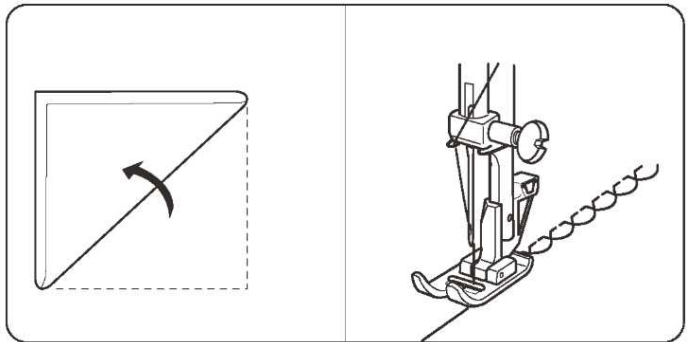

Stretch stitches

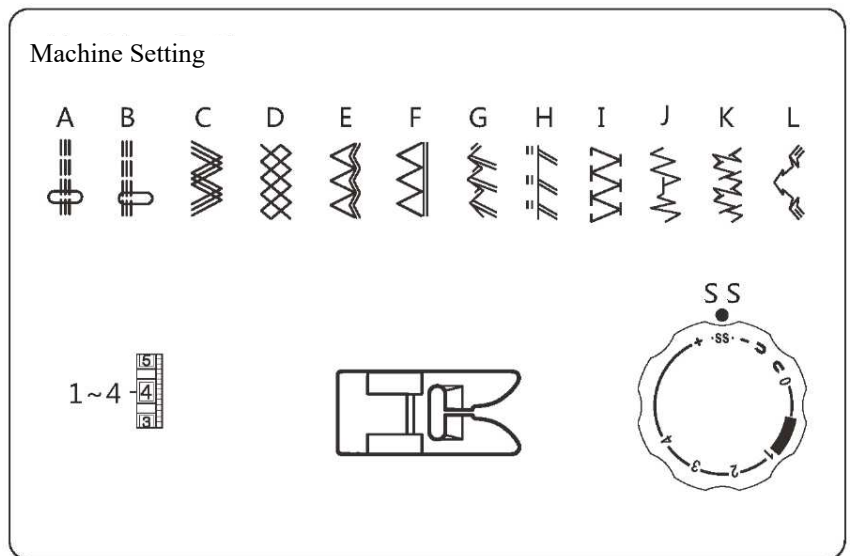

When forward and reverse feed becomes unbalanced, depending upon the type of fabric, correct the balance by turning the stitch length dial as follows:

When patterns are compressed, correct by turning the dial toward “+”.

When patterns are drawn out, correct by turning the dial toward “-”.

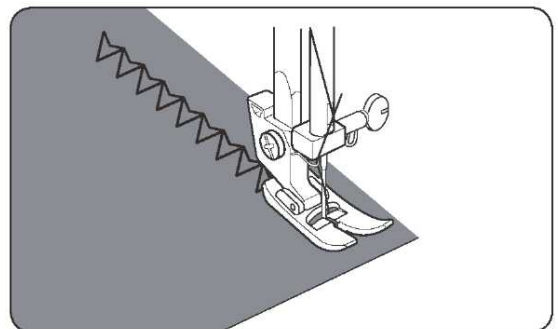

DECORATIVE STITCHING

Decorative satin stitch

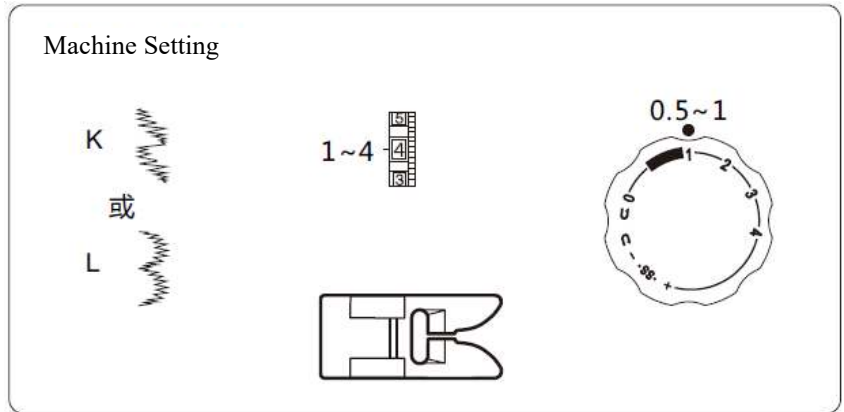

Sew a row of stitches and adjust the thread tension so the upper thread appears slightly on the reverse side of the fabric.
Test the stitch on actual fabric for the best results.

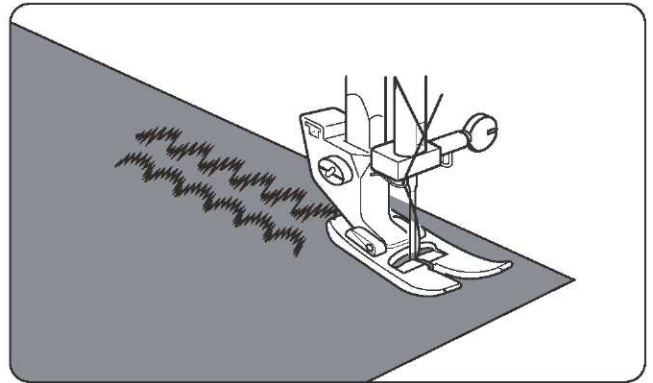

Honeycomb stitch / Smocking

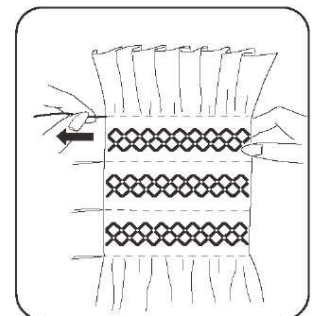
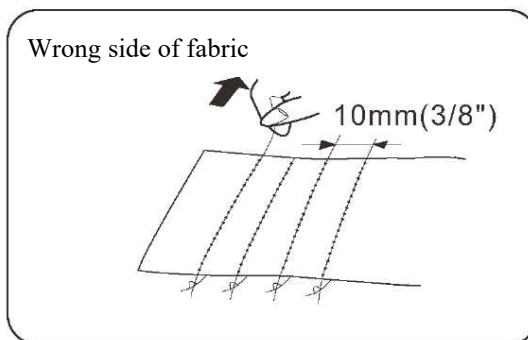
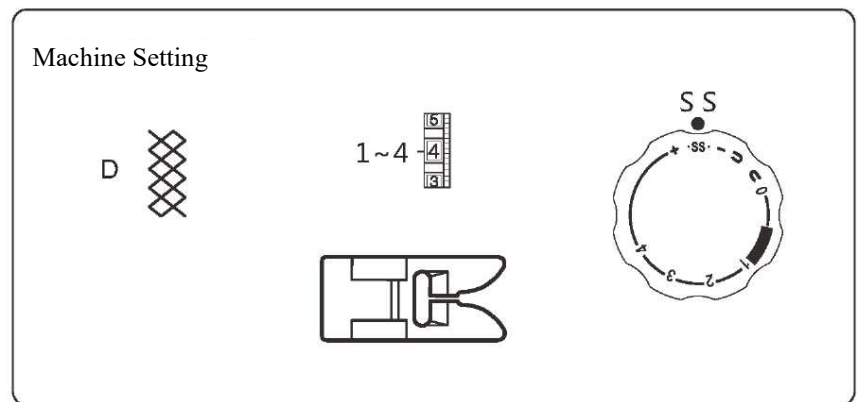

With the stitch length "4", sew straight stitching; lines 3/8 apart across the area to be smocked. Knot the threads along one edge, pull the bobbin threads and distribute the gathers evenly. Secure the thread at the other end. Sew the decorative stitch between the gathering stitches. Pull out the gathering stitches.
NOTE: Loosen the top thread tension to make gathering easier.

DECORATIVE STITCHING

Rampart stitch

Use this stitch to join heavy weight interlining.
Overlap two raw edges together and use this stitch to join them.

Machine Setting

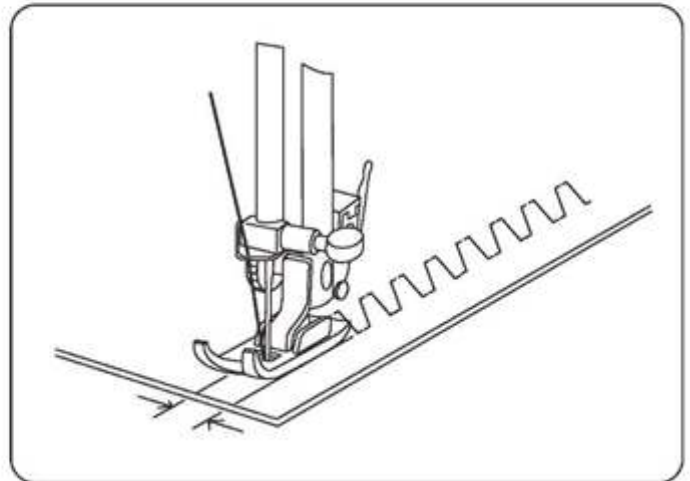
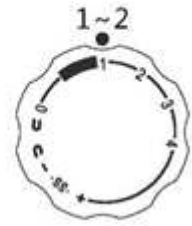
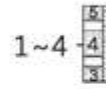

CARE OF YOUR MACHINE

Dismantling and assembling shuttle race

To dismantle the shuttle race and oil the shuttle race

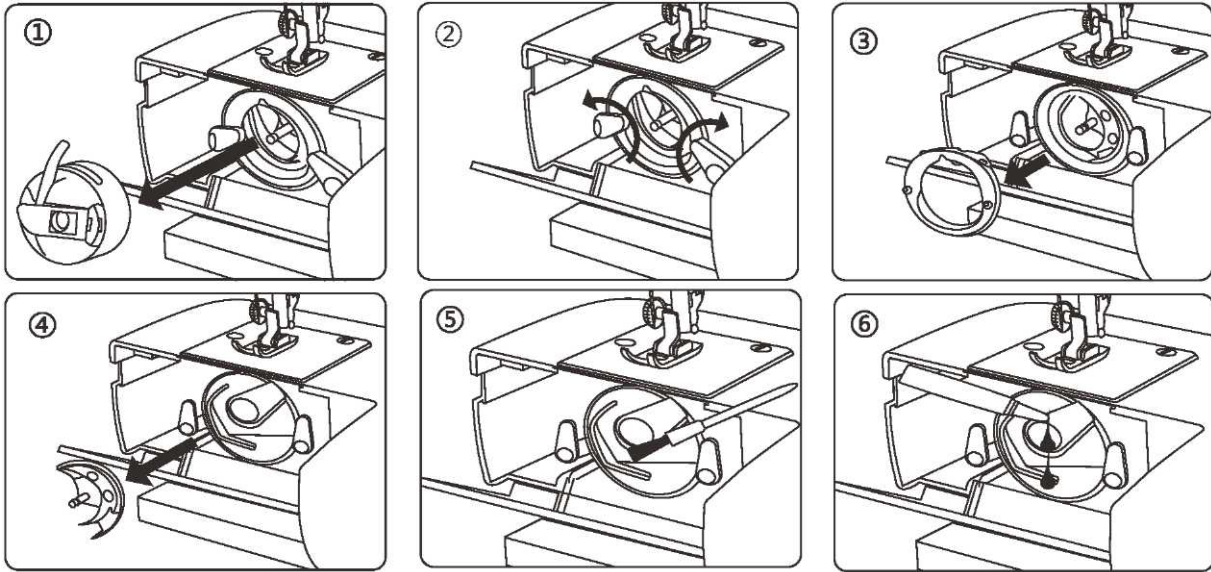

Raise the needle to its highest position and open the shuttle cover.

1. Open the hinged latch of the bobbin case and take it out of the machine.
2. Open the shuttle race cover holders.
3. Remove the shuttle race cover.
4. Remove the shuttle.
5. Clean the shuttle race with a brush and soft dry cloth.
6. Before assembling the shuttle race, oil the shuttle race using a few drops of fine quality sewing machine oil.

Note:

1. Use oil sparingly as over oiling will cause it to leak onto your fabric.
2. In case the machine does not work smoothly due to standing idle for some time, apply a few drops of oil at the oiling point, and turn the machine rapidly for a minute.
3. When the machine is does working 4-8 hours or there is abnormal noise, apply 2-3 drops of sewing machine oil at the oiling point.

To assemble the shuttle race

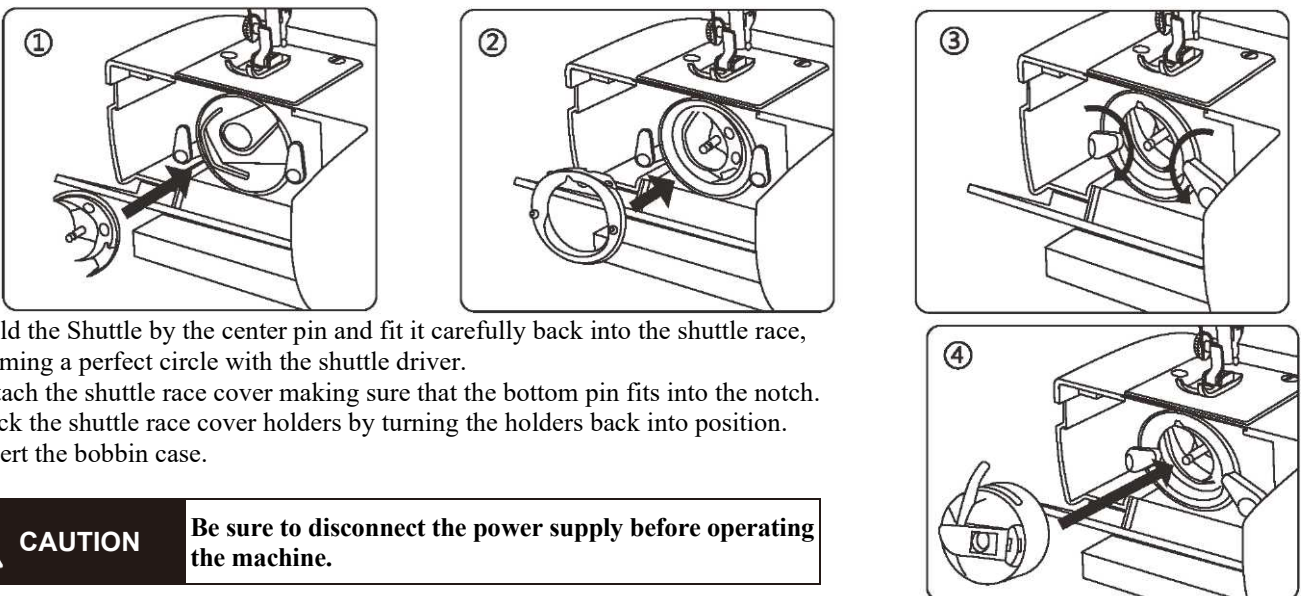

1. Hold the Shuttle by the center pin and fit it carefully back into the shuttle race, forming a perfect circle with the shuttle driver.
2. Attach the shuttle race cover making sure that the bottom pin fits into the notch.
3. Lock the shuttle race cover holders by turning the holders back into position.
4. Insert the bobbin case.



CAUTION

Be sure to disconnect the power supply before operating the machine.

CARE OF YOUR MACHINE

Cleaning the feed teeth

Remove the needle and the presser foot.
Remove the needle plate set screws and
remove the needle plate.

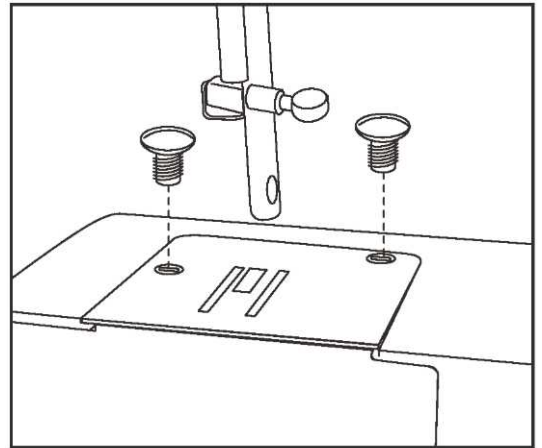

With a brush, clean out dust and lint clogging on the feed teeth. Reset
the needle plate.

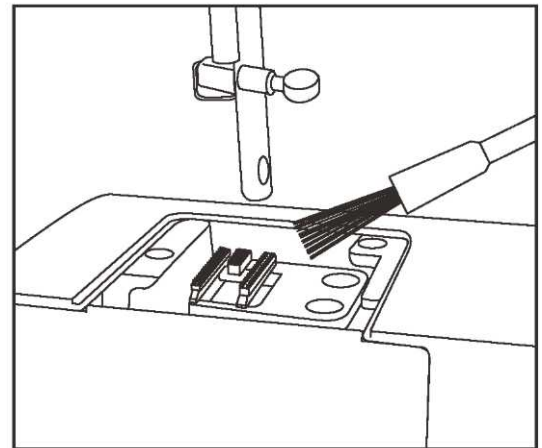

CAUTION

Be sure to disconnect the power supply before operating
the machine.

CARE OF YOUR MACHINE

Oiling the machine

1. Loosen the face cover screw and remove the face cover to left side.
2. Oil the points shown by the arrows.

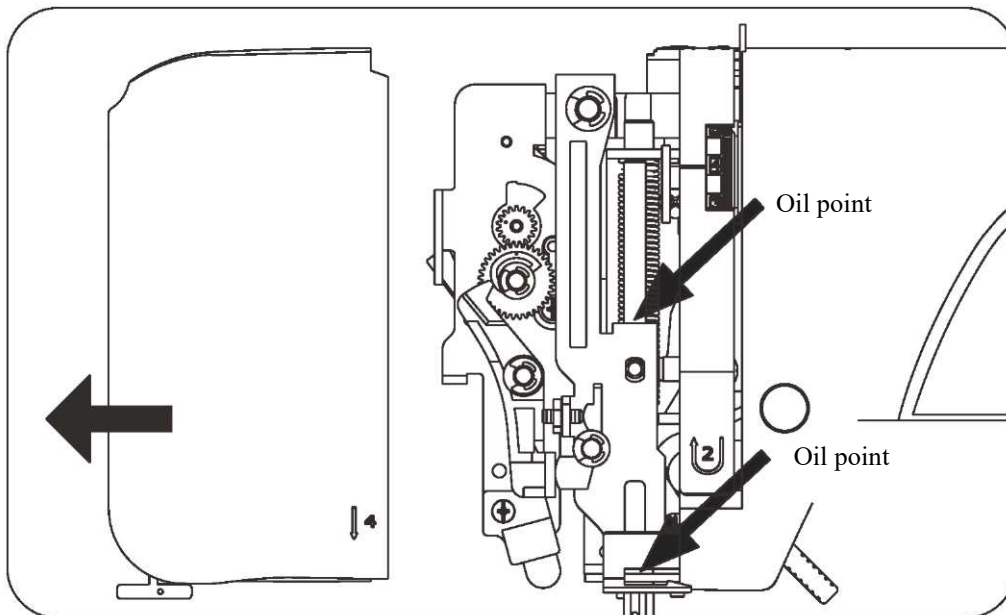
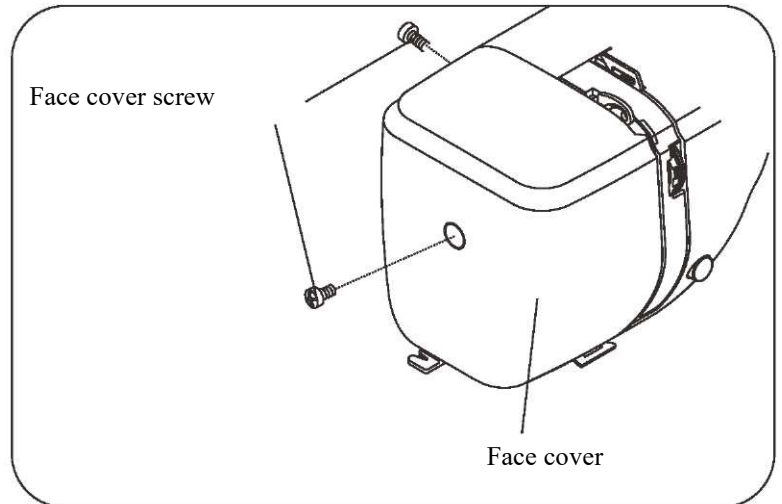

Apply a few drops of fine quality sewing machine oil to the point indicated by the arrows in the figures. For machine in constant use, oil two or three times a year.

In case the machine does not work smoothly due to standing idle for some time, apply a few drops of oil at the oiling point, and turn the machine rapidly for a minute.

Before oiling, wipe off oiling points.



CAUTION

Be sure to disconnect the power supply before operating the machine.

CARE OF YOUR MACHINE

Oiling the connecting rod

1. Loosen the little top cover screw used the screwdriver.
2. Remove the little top cover.

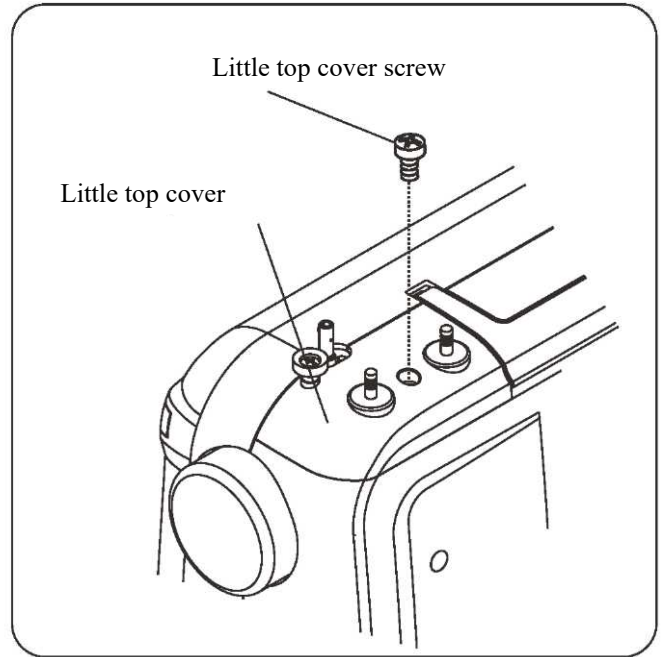

Apply a few drops of fine quality sewing machine oil to the point indicated by the arrows in the figures.
For machine in constant use, oil two or three times a year.
When there is abnormal noise, apply a few drops of sewing machine oil at the oiling point.

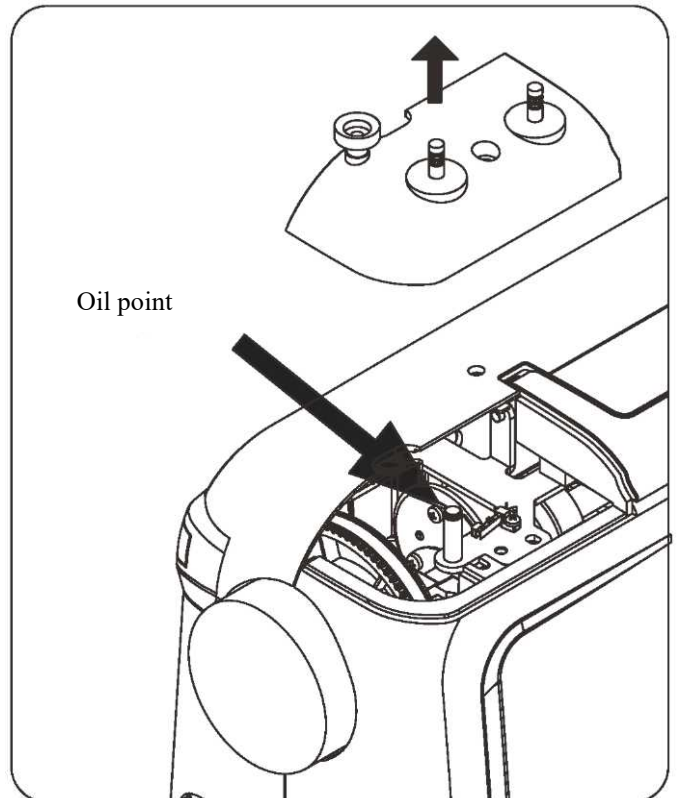

CAUTION

Be sure to disconnect the power supply before operating the machine.

TROUBLESHOOTING

Trouble	Causes	Solution
Top thread broken	<ol style="list-style-type: none"> 1. Improper top threading. 2. Excessively tight top tension. 3. Blunt or bend needle. 4. Improper fixing of needle. 5. At start of sewing, top thread and bottom thread are not correctly placed beneath the presser foot. 6. Thread is unsuitable or poor quality 	<ol style="list-style-type: none"> 1. Threading the top thread again. (Refer to page 7.) 2. Adjust the top tension. (Refer to page 9.) 3. Replace the needle. (Refer to page 10.) 4. Reinstall the needle. (Refer to page 10.) 5. Proper operation. (Refer to page 7, 9.) 6. Replace the proper thread. (Refer to page 10.)
Bobbin thread broken	<ol style="list-style-type: none"> 1. Bobbin not correctly placed into bobbin case. 2. Lint collected on shuttle race. 3. Bobbin is damaged, cannot smoothly rotate. 4. Wrong bobbins being used. 	<ol style="list-style-type: none"> 1. Thread bobbin thread again. (Refer to page 9.) 2. Clean the shuttle race. (Refer to page 23.) 3. Replace the bobbin. (Refer to page 6.) 4. Use only recommended style of bobbins (Refer to page 3.)
Needle broken	<ol style="list-style-type: none"> 1. Improper installation of needle. 2. Blunt or bend needle. 3. Needle clamp screw is loosening. 4. Excessively tight top tension. 5. Needle not correct style/size for fabric. 	<ol style="list-style-type: none"> 1. Reinstall the needle. (Refer to page 10.) 2. Replace the needle. (Refer to page 10.) 3. Tight the needle clamp screw. 4. Adjust the top tension. (Refer to page 9.) 5. Replace the proper needle. (Refer to page 10.)
Skipping stitches	<ol style="list-style-type: none"> 1. Improper installation of needle. 2. Blunt or bend needle. 3. Needle and/or thread unsuitable for fabric being sewn. 4. Improper top threading. 5. Needle is unsuitable for fabric being sewn. 	<ol style="list-style-type: none"> 1. Reinstall the needle. (Refer to page 10.) 2. Replace the needle. (Refer to page 10.) 3. Replace the proper needle and thread. (Refer to page 10.) 4. Threading the top thread again. (Refer to page 7.) 5. Replace the proper needle. (Refer to page 10.)
Seam puckering	<ol style="list-style-type: none"> 1. Excessively tight top tension. 2. Improper top threading. 3. Excessively thick top thread for fabric. 	<ol style="list-style-type: none"> 1. Adjust the top tension. (Refer to page 9.) 2. Threading the top thread again. (Refer to page 7.) 3. Replace the proper thread. (Refer to page 10.)
Machine not feeding fabric	<ol style="list-style-type: none"> 1. Feed teeth are wound by thread. 2. Thread jams. 3. Stitch length is set at "0" 	<ol style="list-style-type: none"> 1. Clean the feed teeth. (Refer to page 24.) 2. Clean the clamping thread. 3. Select stitch length setting longer than "0".
Machine not running	<ol style="list-style-type: none"> 1. Not surely inserting power plug. 2. Clamping thread at shuttle race. 3. Failure to replace the bobbin winding spindle to original position after winding bobbin. 	<ol style="list-style-type: none"> 1. Check the power connector. (Refer to page 3.) 2. Clean the clamping thread. 3. Push the bobbin winding spindle to original position. (Refer to page 5.)
Thread jamming	<ol style="list-style-type: none"> 1. The presser foot lifter is not lowered down when sewing. 2. Improper top threading. 3. Improper bobbin threading. 	<ol style="list-style-type: none"> 1. Rethread the machine and then lower the presser foot lifter before sewing. (Refer to page 4.) 2. Threading the top thread again. (Refer to page 7.) 3. Thread bobbin thread again. (Refer to page 9.)

We reserve the right to change the machine equipment and the assortment of accessories without prior notice, or make modifications to the performance or design. Such modifications, however, will always be to the benefit of the user and the product.

INTELLECTUAL PROPERTY

SINGER, and the Cameo "S" Design, are exclusive trademarks of The Singer Company Limited S.a.r.l. or its Affiliates.



Please note that on disposal, this product must be safely recycled in accordance with relevant National legislation relating to electrical/electronic products. Do not dispose of electrical appliances as unsorted municipal waste, use separate collection facilities. Contact your local government for information regarding the collection systems available. When replacing old appliances with new ones, the retailer may be legally obligated to take back your old appliance for disposal free of charge.

If electrical appliances are disposed of in landfills or dumps, hazardous substances can leak into the groundwater and get into the food chain, damaging your health and well-being.

MANUFACTURER

VSM Group AB, SVP Worldwide

Drottningatan 2, SE-561-84 Huskvarna, SWEDEN

