

User's Guide

Designer Jade™ | 35



This household sewing machine is designed to comply with IEC/EN 60335-2-28 and UL1594.

IMPORTANT SAFETY INSTRUCTIONS

When using an electrical appliance, basic safety precautions should always be followed, including the following:

Read all instructions before using this household sewing machine. Keep the instructions at a suitable place close to the machine. Make sure to hand them over if the machine is given to a third party.

DANGER –TO REDUCE THE RISK OF ELECTRIC SHOCK:

- A sewing machine should never be left unattended when plugged in. Always unplug this sewing machine from the electric outlet immediately after using and before cleaning, removing covers, lubricating or when making any other user servicing adjustments mentioned in the instruction manual.

WARNING –TO REDUCE THE RISK OF BURNS, FIRE, ELECTRIC SHOCK, OR INJURY TO PERSON:

- Do not allow to be used as a toy. Close attention is necessary when this sewing machine is used by or near children.
- Use this sewing machine only for its intended use as described in this manual. Use only attachments recommended by the manufacturer as contained in this manual.
- Never operate this sewing machine if it has a damaged cord or plug, if it is not working properly, if it has been dropped or damaged, or dropped into water. Return the sewing machine to the nearest authorized dealer or service center for examination, repair, electrical or mechanical adjustment.
- Never operate the sewing machine with any air openings blocked. Keep ventilation openings of the sewing machine and foot control free from the accumulation of lint, dust, and loose cloth.
- Keep fingers away from all moving parts. Special care is required around the sewing machine needle.
- Always use the proper needle plate. The wrong plate can cause the needle to break.
- Do not use bent needles.
- Do not pull or push fabric while stitching. It may deflect the needle causing it to break.
- Wear safety glasses.
- Switch the sewing machine off (“0”) when making any adjustment in the needle area, such as threading needle, changing needle, threading bobbin, or changing presser foot, etc.
- Never drop or insert any object into any opening.
- Do not use outdoors.
- Do not operate where aerosol (spray) products are being used or where oxygen is being administered.
- To disconnect, turn all controls to the off (“0”) position, then remove plug from outlet.
- Do not unplug by pulling on cord. To unplug, grasp the plug, not the cord.
- The foot control is used to operate the machine. Avoid placing other objects on the foot control.
- Do not use the machine if it is wet.

- If the LED lamp is damaged or broken, it must be replaced by the manufacturer or its service agent or a similarly qualified person, in order to avoid a hazard.
- If the cord connected with the foot control is damaged, it must be replaced by the manufacturer or its service agent or a similarly qualified person, in order to avoid a hazard.
- This sewing machine is provided with double insulation. Use only identical replacement parts. See instructions for Servicing of Double-Insulated Appliances.

SAVE THESE INSTRUCTIONS

FOR EUROPE ONLY:

This appliance can be used by children aged from 8 years and above and persons with reduced physical, sensory or mental capabilities or lack of experience and knowledge if they have been given supervision or instruction concerning use of the appliance in a safe way and understand the hazards involved. Children shall not play with the appliance. Cleaning and user maintenance shall not be made by children without supervision.

The noise level under normal operating conditions is less than 70 dB.

The machine must only be used with foot control of type C-9002 manufactured by CHIEN HUNG TAIWAN Ltd.

FOR OUTSIDE EUROPE:

This sewing machine is not intended for use by persons (including children) with reduced physical, sensory or mental capabilities, or lack of experience and knowledge, unless they have been given supervision or instruction concerning use of the sewing machine by a person responsible for their safety. Children should be supervised to ensure that they do not play with the sewing machine.

The noise level under normal operating conditions is less than 70 dB.

The machine must only be used with foot control of type C-9002 manufactured by CHIEN HUNG TAIWAN Ltd.

SERVICING OF DOUBLE INSULATED PRODUCTS

In a double-insulated product, two systems of insulation are provided instead of grounding. No ground means is provided on a double-insulated product, nor should a means for grounding be added to the product. Servicing of a double-insulated product requires extreme care and knowledge of the system and should be done only by qualified service personnel. Replacement parts for a double-insulated product must be identical to those parts in the product. A double-insulated product is marked with the words 'DOUBLE INSULATION' or 'DOUBLE INSULATED'.

TABLE OF CONTENTS

I	Introduction	6	Updating Instructions	24	
	Machine Overview	6	Function Buttons.....	25	
	Front	6	Needle Stop Up/Down With Indicator (Trim Position).....	25	
	Needle Area	7	STOP Function (Monochrome).....	25	
	Rear Side	7	FIX Function (Baste).....	26	
	Storage Box	7	Cut Function.....	26	
	Accessory Tray	7	Speed + and –	26	
	Embroidery Unit.....	8	Start/Stop.....	26	
	Accessories.....	8	Reverse	26	
	Included Accessories	8	Stitch Selection Buttons.....	26	
	Presser Feet.....	9	Delete	26	
	Stitch Overview.....	10	Stitch Length/Density/Elongation and Design Height	26	
	Utility Stitches	10	Stitch Width/Needle Position and Design Width.....	26	
	Stitch Menus	11	Alternate View (ALT)	27	
	Alphabets	12	Step Stitch by Stitch – and +	27	
	Block	12	Navigator Arrows and OK	27	
	Cyrillic	12	Step Color by Color – and +	27	
2	Preparations	13	Mirror End to End.....	27	
	Unpacking.....	13	Mirror Side to Side	27	
	Connect the Power Cord and Foot Control.....	13	Rotate Design.....	27	
	Pack Away After Sewing.....	14	Hoop Options.....	27	
	LED Lights	14	Embroidery Info Button	27	
	Free Arm.....	14	SET Menu (Settings Menu).....	27	
	Mounting Machine in Sewing Cabinet.....	14	Corner Check.....	27	
	Spool Pins.....	15	Stitch Menu/Load Design	27	
	Threading the Machine	16	Font Menu.....	27	
	Needle Threader	16	Shift to Uppercase, Lowercase or Numbers	27	
	Cutting the Thread	17	Program Mode (PROG).....	27	
	Threading for Twin Needle.....	17	Save Stitch or Program.....	28	
	Bobbin Winding.....	18	Exclusive SEWING ADVISOR™	28	
	Winding From Horizontal Position	18	SET Menu.....	29	
	Winding Through the Needle.....	19	Thread Tension	29	
	Inserting the Bobbin.....	19	FIX Auto (Only in Sewing Mode)	29	
	Thread Tension.....	19	CUT Auto (Only in Sewing Mode).....	29	
	Thread Sensor	20	Automatic Stop for Cut (Only in Embroidery Mode).....	30	
	Lowering the Feed Teeth.....	20	Twin Needle.....	30	
	Presser Foot Pressure	20	Stitch Width Safety.....	30	
	Presser Foot Lift.....	20	Audible Alarm.....	30	
	Changing the Presser Foot.....	20	Contrast	30	
	Threads	21	Language	31	
	Stabilizers.....	21	Software Version.....	31	
	Needles.....	22	3	Sewing Mode	32
	Important Needle Information.....	22		Sewing Mode Overview	32
	Changing the Needle.....	23		Selecting a Stitch.....	34
	USB Port	23		Selecting a Font	34
	USB Embroidery Stick.....	23		Exclusive SEWING ADVISOR™	35
	Connect to and Remove From USB Port.....	23		Fabric Selection	35
	Complimentary Embroidery Intro			Woven or Stretch (Knit)	35
	Software (PC).....	24		Leather and Vinyl.....	36
	How to Update Your Machine.....	24		Sewing Techniques.....	36

Stitch Settings	37	DESIGNER JADE™ 35 Sampler Book	59
Stitch Length/Stitch Density	37	Download Backup Designs	60
Stitch Width	37	Connect the Embroidery Unit	60
Elongation	38	Remove the Embroidery Unit	60
Needle Position	38	Attaching the Embroidery/Darning Foot U....	61
Mirroring	38	To Hoop the Fabric	61
Sewing Pop-Up Messages	39	Slide on/off the Hoop	62
4 Program	41	Getting Started Embroidering	62
Create a Stitch Program	41	7 Embroidery Mode	64
Add Letters	41	Embroidery Mode Overview	64
About Programming Letters	41	Edit View	64
Add Stitches or Letters at Other Positions ...	42	Stitch-Out View	64
Add the Same Stitch Several Times	42	Load a Design	65
Delete Stitches or Letters	42	Load a Font	65
Add Commands	42	Add a Letter	65
Join Two Stitch Programs Into One	42	Delete a Letter	66
Adjust a Single Stitch or Letter	43	Load Text to Embroidery	66
Adjust the Entire Stitch Program	43	Embroidery Information	67
Sew out the Stitch Program	43	Adjust Designs	68
Machine Memory	43	Design Height	68
Save a Stitch or a Program	44	Design Width	68
Load a Saved Stitch or Program	44	Move Designs to Position	68
Program Pop-Up Messages	45	Rotate and Mirror Design	68
Overwrite?	45	Hoop Options	69
The Combination of Commands is Incorrect	45	Hoop Size	69
5 Sewing Techniques	46	Current Stitch	69
Seam	46	Park Position	69
Overcast	47	Trim Position	69
Seam and Overcast	48	Center Position	69
Baste	48	Embroidery Functions	70
Blind Hem	49	One-Color Embroidery (Monochrome)	70
Hem	50	Basting	70
Jeans Hem	50	Park Position/Trim Position	70
Stretch Hem	51	Corner Check	70
Sewing Buttonholes	51	Step Stitch by Stitch	70
One-Step Buttonhole	52	Step Color by Color	71
Manual Buttonhole	53	Embroidery Pop-Up Messages	71
Corded Buttonhole (Stretch Fabrics)	54	8 Maintenance	74
Sewing on Buttons	54	Cleaning the Machine	74
Sewing Zippers	55	Cleaning the Bobbin Area	74
Center Zipper	55	Cleaning Under the Bobbin Area	74
Darning and Mending	56	Replacing the Needle Plate	75
Bartack (Manual)	56	Troubleshooting	75
Quilting	57	Technical specification	78
Crazy Quilt Stitching	57	Index	79
Hand-Look Quilting	57		
Free Motion Quilting	58		
6 Embroidery Preparations	59		
Embroidery Unit	59		
Embroidery Hoop Overview	59		
Designs	59		

I Introduction

Machine Overview

Front

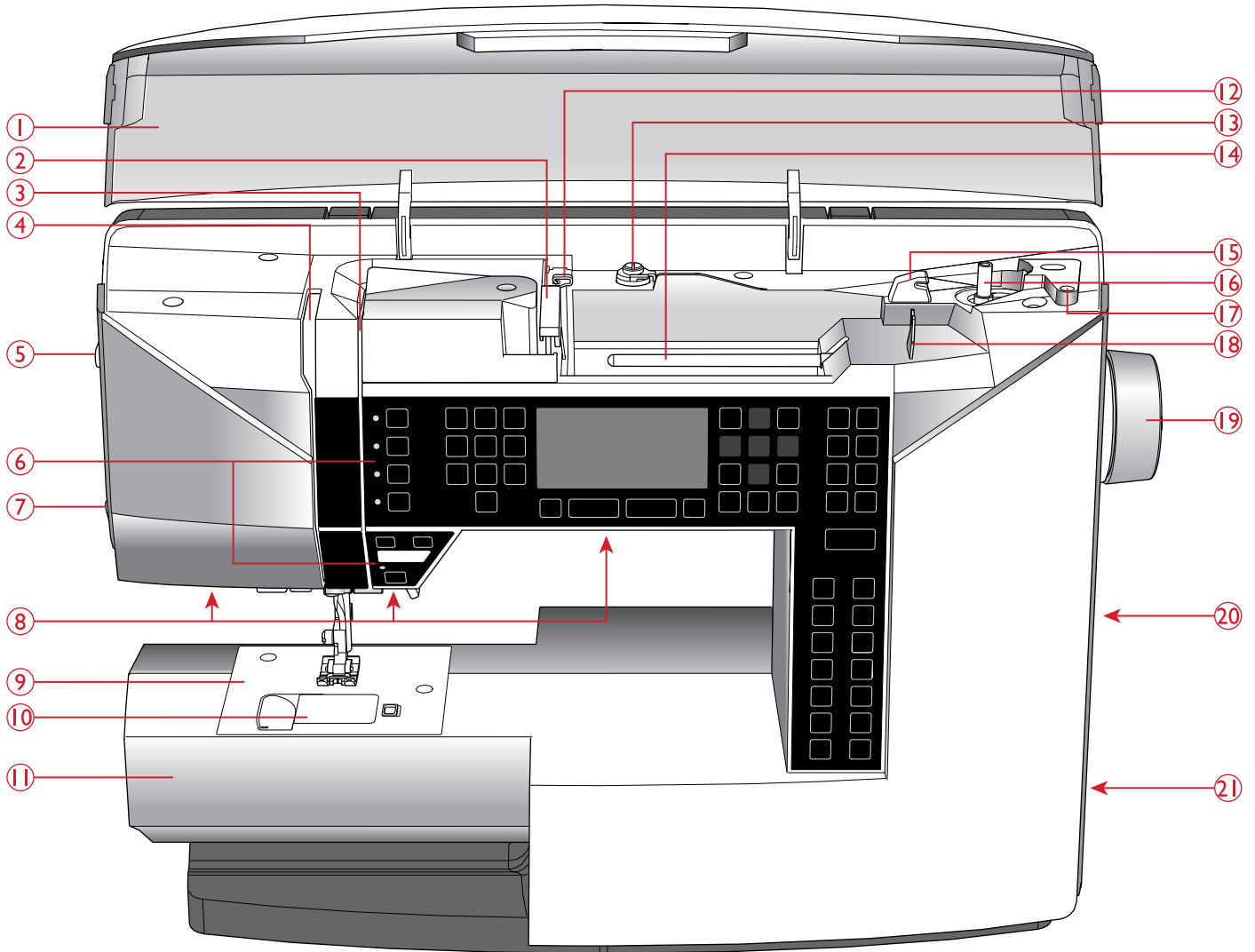

- | | |
|---------------------------------------|--|
| 1. Lid with stitch overview | 12. Thread guide for auxiliary spool |
| 2. Thread guide | 13. Bobbin winder thread guide and tension disc |
| 3. Thread tension discs | 14. Spool pin |
| 4. Thread take-up lever | 15. Thread cutter for bobbin thread |
| 5. Presser foot pressure dial | 16. Bobbin spindle, bobbin stop |
| 6. Function panel and graphic display | 17. Hole for auxiliary spool pin |
| 7. Thread cutter | 18. Thread guide for bobbin winding through the needle |
| 8. LED lights | 19. Handwheel |
| 9. Needle plate | 20. USB port |
| 10. Bobbin cover | 21. ON/OFF switch, sockets for power cord and foot control |
| 11. Free arm | |

Needle Area

1. Buttonhole lever
2. Needle threader
3. Presser foot ankle
4. Presser foot
5. Needle bar
6. Needle clamp screw
7. Needle thread guide
8. Presser foot lift
9. Presser bar

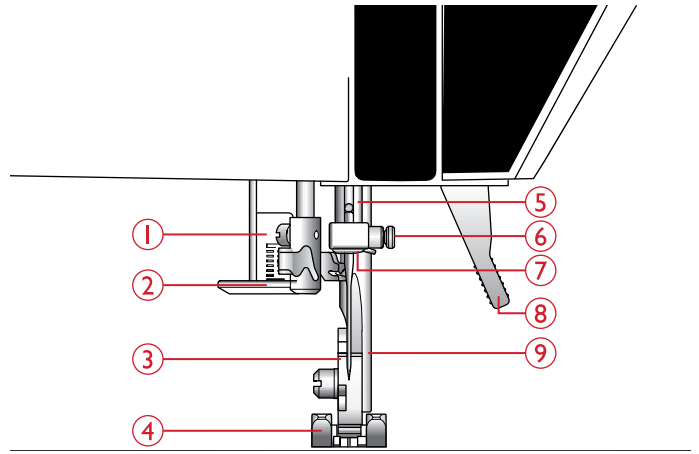

Rear Side

1. Handle
2. Embroidery unit connection socket
3. Drop feed teeth switch

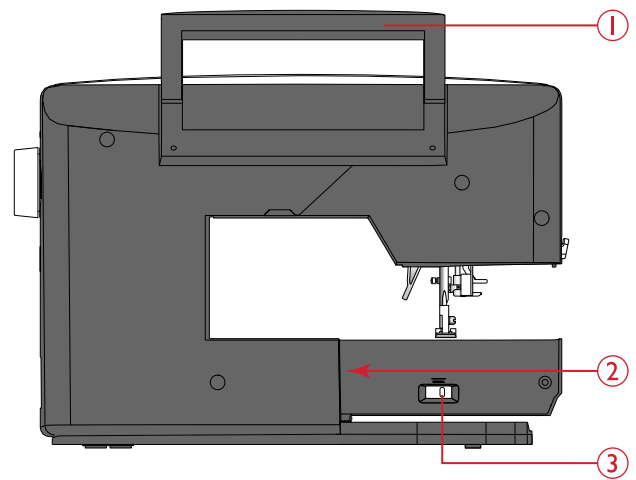

Storage Box

The storage box is for storing the foot control, power cord and any accessories.

For instructions on how to remove the storage box from the machine, see [Unpacking, page 13](#).

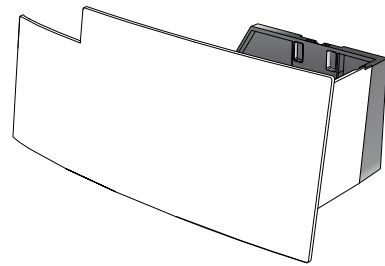

Accessory Tray

Store the accessories in the tray so they are easily accessible.

Keep the accessory tray on the machine to provide a larger, flat work surface.

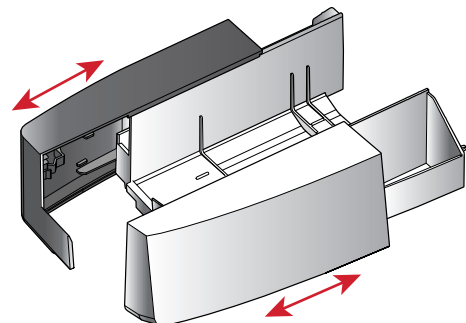

Embroidery Unit

(type EU-3V)

1. Embroidery unit plug
2. Embroidery arm
3. Embroidery unit release button (underside)
4. Level adjustment feet
5. Embroidery hoop attachment

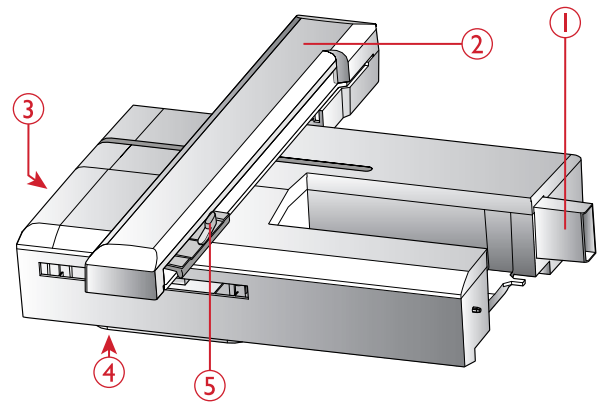

Accessories

Included Accessories

1. Thread net
2. Edge guide
3. Felt pad (2)
4. Bobbins (5, one is on the machine)
5. Screwdriver
6. Auxiliary spool pin
7. Seam ripper
8. Brush. Use the sharp edge of the brush to clean the area around the feed teeth.
9. Screwdriver for needle plate
10. Spool cap, small
11. Spool cap, large
12. USB embroidery stick with embroidery designs and HUSQVARNA VIKING® DESIGNER JADE™ 35 sampler book
13. Long needle clamp screw for free motion sewing with over 4mm stitch width and for optional accessories that rest on the needle clamp screw when mounted
14. DESIGNER™ Jewel Hoop (240x150)

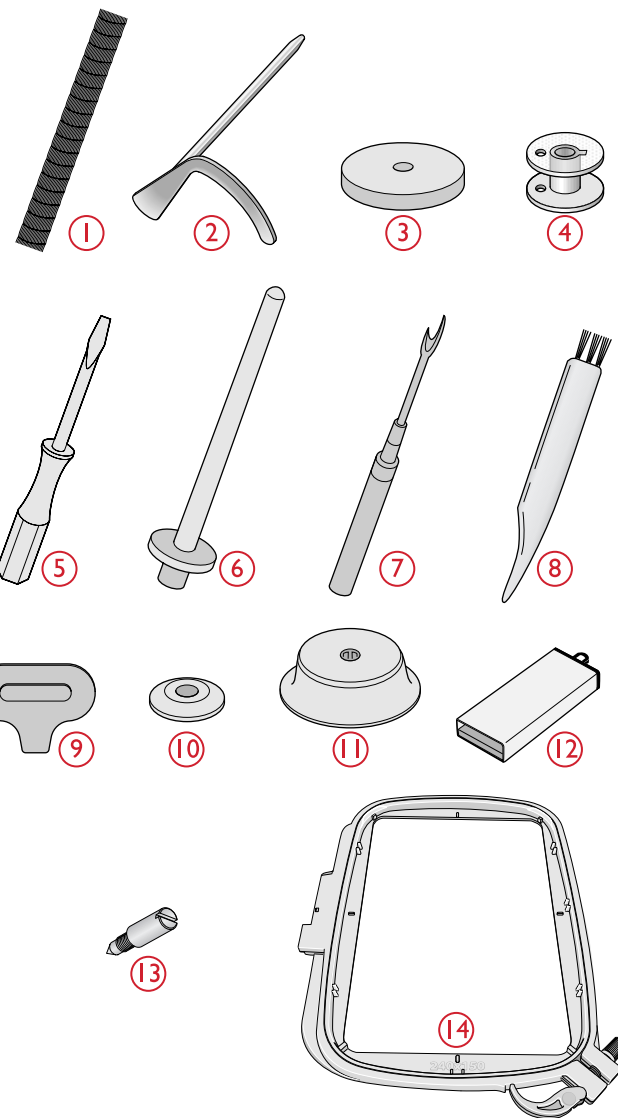

Included Accessories Not in Picture

- Foot control
- Power cord
- Needles

Presser Feet

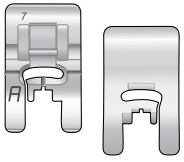

Utility Foot A

Attached on the machine upon delivery. This foot is used mainly for straight stitching and zigzag stitching with a stitch length longer than 1.0.

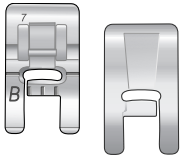

Decorative Stitch Foot B

When sewing decorative stitches or short zigzag stitches and other utility stitches with less than 1.0 mm stitch length, use this foot. The tunnel on the underside of the foot is designed to feed smoothly over the stitches.

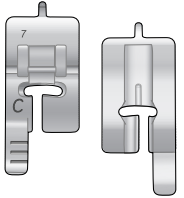

Buttonhole Foot C

This foot is used for sewing buttonholes step by step. Use the guide lines on the toe of the foot to position the garment edge. The two tunnels on the bottom of the foot ensures a smooth feed over the buttonhole columns. The finger on the back of the foot holds cording for corded buttonhole.

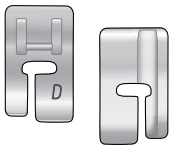

Blind Hem Foot D

This foot is used for blind hem stitches. The inner edge of the foot guides the fabric. The right toe of the foot is designed to ride along the hem edge.

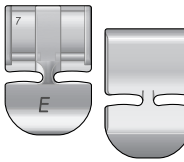

Zipper Foot E

This foot can be snapped on either to the right or to the left of the needle, making it easy to sew close to both sides of the zipper teeth. Move needle position to the right or left to sew closer to the zipper teeth or for covering large cording.

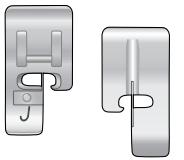

Edging Foot J

This foot is used for overcasting and seam/overcasting. Stitches form over the pin which prevents puckering at the edge of the fabric.

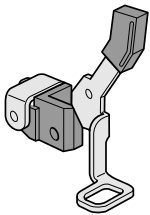

Embroidery/Darning Foot U

Used for hoop embroidery, free motion embroidery, free motion quilting, free motion stitching and free motion darning.

Note: When free motion sewing with more than 4mm stitch width, replace the short needle clamp screw with the long needle clamp screw found in the included accessories.

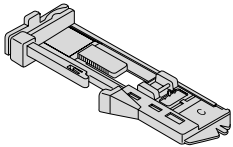

One-Step Buttonhole Foot

This foot has a space in the back for a button used to set the size of the buttonhole. The machine will sew a buttonhole to fit that button size. Used to sew buttonholes up to 25 mm.

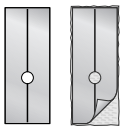































Self-Adhesive Glide Plate

If sewing on foam, vinyl, plastic, or leather, the material can stick to the foot and prevent the sewing machine from feeding properly. When using any of the above materials, sew on a piece of scrap fabric, to make sure the machine feeds smoothly. If not, fasten the self-adhesive glide plate to the underside of the presser foot.































Stitch Overview































Utility Stitches































Stitch	№	Presser foot	Name	Description
	0	One-Step Buttonhole Foot/C	Bartack buttonhole	Standard buttonhole for most fabric weights.
	1	A/B	Straight stitch, center needle position	For all types of sewing.
	2	A/B	Stretch stitch, left needle position	For seams in tricot and stretch fabrics.
	3	A/B	Reinforced straight stitch, center needle position	Triple and elastic, for reinforced seams. For topstitch, increase the stitch length.
	4	J/B	Three-step zigzag	For overcasting, mending, sewing on patches and elastic. Suitable for light and medium weight fabrics.
	5	A/B	Zigzag	For sewing on lace, trims and appliqués.
	6	A/B	Flatlock stitch	Decorative hems and overlapped seams, belts and bands. For medium/heavy stretch fabrics.
	7	J	Seam/overcast stitch	Seam and overcast in one step along the edge or trim later. For light stretch and non-stretch fabrics.
	8	A/B	Stretch seam/overcast stitch	Seam and overcast in one step along the edge or trim later. For medium and heavy stretch fabrics.
	9	–	Automatic button sewing	For sewing on buttons.
	10	A/B	Two-step zigzag	For joining two pieces of lace, and for elastic shirring.
	11	A	Reinforced zigzag	For joining fabric edge to edge or overlapping in leather. For decorative sewing.
	12	A/B	Basting stitch	For temporary seams. The long stitches and reduced tension make the seams easy to unravel.
	13	A/B	Double overlock stitch	Seam and overcast in one step along the edge or trim later. For heavy stretch and heavy woven fabrics.
	14	A/B	Overlock stitch	Seam and overcast in one step along the edge or trim later. For medium stretch fabrics.
	15	A/B	Elastic/casing stitch	For overlapped seams in tricot. To sew casing over narrow elastic.
	16	A/B	Elastic stitch or smocking	Sew over two rows of elastic thread for elastic shirring.
	17	D	Stretch blind hem stitch	Blind hems in medium and heavy stretch fabrics.
	18	D	Woven blind hem stitch	Blind hems in medium and heavy woven fabrics.
	19	A/B	Bridging stitch	For joining two pieces of fabric with finished edges and for elastic shirring.
	20	B	Herringbone stitch	Elastic decorative hem for stretch fabrics.































Stitch	№	Presser foot	Name	Description
	21	B	Darning stitch	Darn and mend small holes in work clothes, jeans, tablecloths and linen towels. Stitch over the hole, press reverse for continuous darning and auto stop.
	22	A/B	Bartack, manual	Reinforce pockets, shirt openings, belt loops as well as at lower end of a zipper.
	23	B	Eyelet	For belts, laces, etc.
	24	One-Step Buttonhole Foot/C	Round end buttonhole	For blouses and children's garments.
	25	C	Medium/heavy reinforced buttonhole	For medium and heavy fabrics
	26	One-Step Buttonhole Foot/C	Heirloom buttonhole	For hand look on fine and delicate fabrics. <i>Tip: For jeans buttonholes, increase length and width of the buttonhole. Use thicker thread.</i>
	27	One-Step Buttonhole Foot/C	Keyhole buttonhole	Square end for tailored jackets, coats, etc.
	28	One-Step Buttonhole Foot/C	Heavy duty buttonhole	With reinforced bartacks.
	29	A/B	Leather buttonhole (straight stitch)	For leather and suede.

Stitch Menus

1                              

2                              

3                              

4                              

Menu 1: Utility stitches

Menu 2: Quilt stitches

Menu 3: Satin and heirloom stitches

Menu 4: Decorative stitches

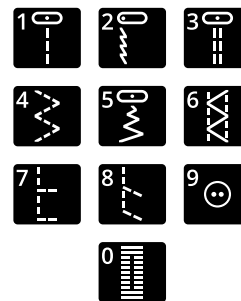

Stitches 0-9 are the same in all four stitch menus.

Alphabets

Block

A B C D E F G H I J K L M N O P Q R S T U U V W X Y Z Ä Å Ö - , _
a b c d e f g h i j k l m n o p q r s t u ü v w x y z å ä ö @ , . _
1 2 3 4 5 6 7 8 9 0 Æ æ Ø ø à á ç ë è é ê í ó ù ú Ñ ñ ß & ? ! ' . _

Cyrillic

Russian alphabet. See the font on the graphic display of your sewing machine.

2 Preparations

Unpacking

1. Place the box on a sturdy, flat surface. Lift the machine out of the box and remove all packing material and the plastic bag.
2. To remove the storage box, turn the locking device located at the rear side of the box to the left and push the box forward.
3. Wipe the machine, particularly around the needle and needle plate to remove any oil before sewing.

Note: Your HUSQVARNA VIKING® DESIGNER JADE™ 35 machine is adjusted to provide the best stitch result at normal room temperature. Extreme hot and cold temperatures can affect the sewing result.

Note: Some fabrics have excess dye which can cause discoloration on other fabrics or on your sewing machine. This discoloration may be very difficult or impossible to remove.

Fleece and denim fabric, especially red and blue, often contain excess dye.

If you suspect that your fabric/ ready-to-wear garment contains a lot of excess dye, always pre-wash it before sewing/ embroidering to prevent discoloration of your machine.

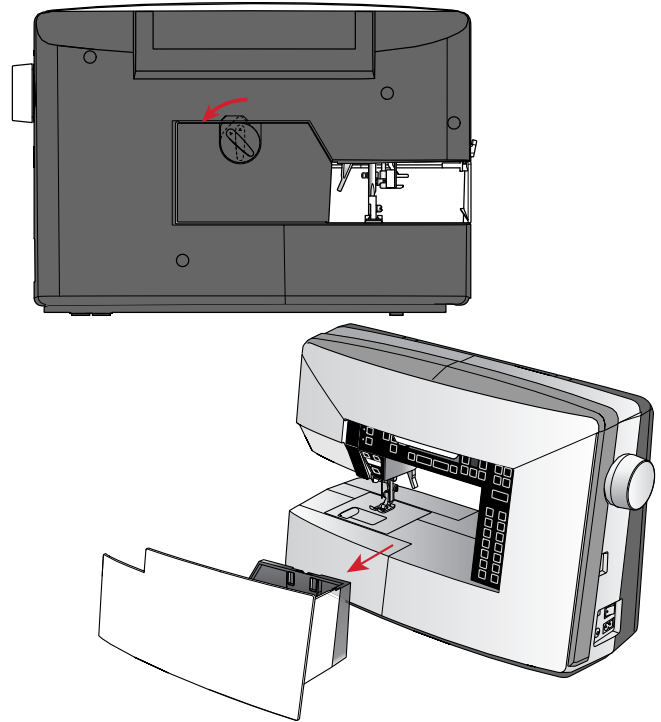

Connect the Power Cord and Foot Control

Among the accessories you will find the power cord and the foot control.

Note: Consult a qualified electrician if you are in doubt about how to connect the machine to the power source. Unplug the power cord when the machine is not in use.

For this sewing machine, foot control model C-9002 manufactured by CHIEN HUNG TAIWAN Ltd must be used.

1. Connect the foot control cord to the front socket on the bottom right side of the machine (A).
2. Connect the power cord to the rear socket on the bottom right side of the machine (B). Plug the cord into the wall socket.
3. Press the ON/OFF switch to ON to turn on power and light (C).

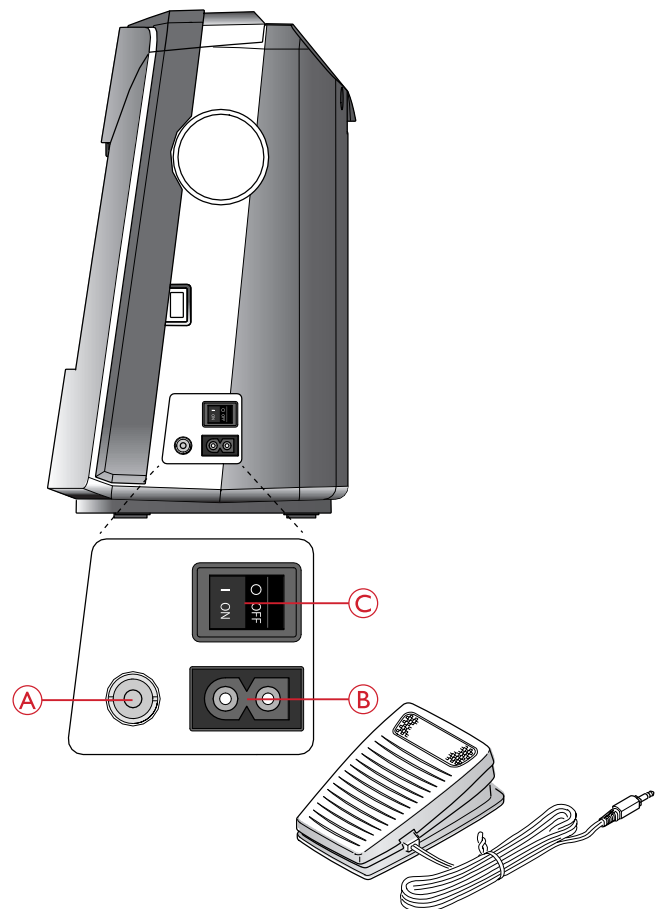

For the USA and Canada

This sewing machine has a polarized plug (one blade wider than the other). To reduce the risk of electric shock, this plug is intended to fit in a polarized outlet only one way. If the plug does not fit fully in the outlet, reverse the plug. If it still does not fit, contact a qualified electrician to install the proper outlet. Do not modify the plug in any way.

Pack Away After Sewing

1. Press the ON/OFF switch to “O”.
2. Unplug the cord from the wall socket and then from the machine.
3. Unplug the foot control cord from the machine. Wind the cord around the foot control and place it inside the storage box.
4. Place all accessories in the accessory tray. Slide the tray on to the machine around the free arm.
5. Place the storage box on the machine and turn the locking device to lock the box in place.

LED Lights

Your machine has LED lights which distribute the light evenly over the sewing area and eliminate shadows.

Free Arm

To use the free arm, slide off the accessory tray. Remove the tray by sliding it to the left.

Use the free arm to facilitate sewing pant legs and sleeve hems.

To replace the accessory tray, slide it onto the machine until it fits in place.

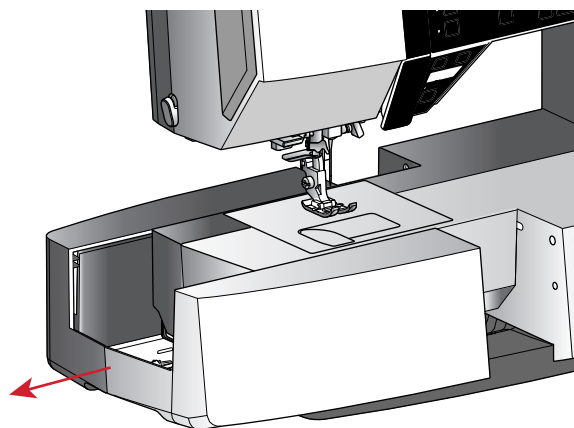

Mounting Machine in Sewing Cabinet

There are two holes on the underside of the machine designed for mounting the machine into a sewing cabinet. Attach the machine with M6 screws.

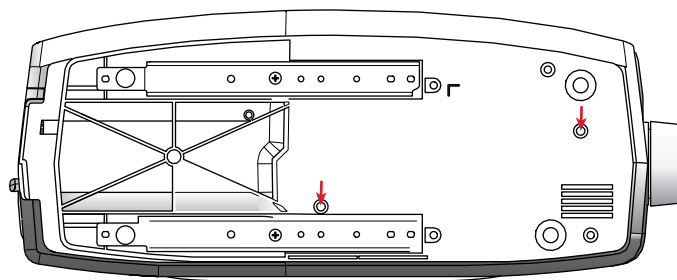

Spool Pins

Your machine has two spool pins, a main spool pin and an auxiliary spool pin. The spool pins are designed for all types of thread. The main spool pin is adjustable and can be used both in a horizontal position (the thread reels off the spool) and a vertical position (the thread spool rotates). Use the horizontal position for normal threads and the vertical position for large spools or specialty threads.

Horizontal Position

Place a felt pad and the thread spool on the spool pin. Make sure that the thread reels off from the front of the spool (A) and slide on a spool cap.

Note: Not all thread spools are manufactured in the same way. If you experience problems with the thread, turn the spool so that the thread reels off in the opposite direction or place the thread in the vertical position.

Depending on the size of thread spool, reverse the direction of the spool cap (B).

Use the small cap when you use cross wound thread (C).

Set the thread net over the spool if thread reels off too easily (D).

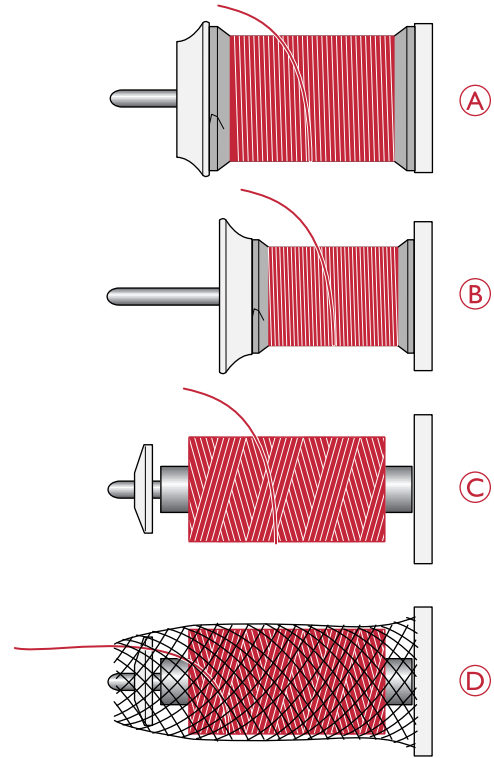

Vertical Position

Raise the spool pin to the vertical position. Place a felt pad under the thread spool. This is to prevent the thread from reeling off too fast. Do not place a spool cap on top of the spool pin as that would prevent the spool from rotating.

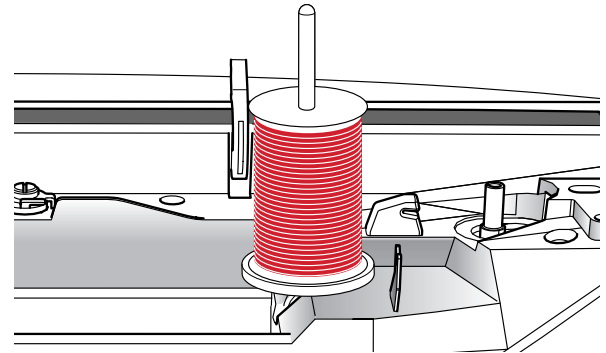

Auxiliary Spool Pin

The auxiliary spool pin is used when winding a bobbin thread from a second spool of thread or for a second spool when sewing with a twin needle. Insert the auxiliary spool pin into the hole at the top of the machine (A). Place a felt pad under the thread spool.

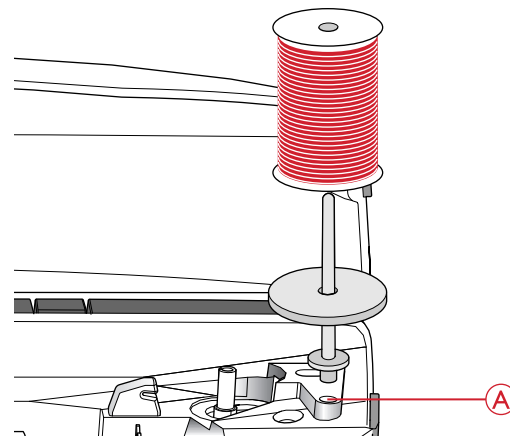

Threading the Machine

Make sure that the presser foot is raised and the needle is in its highest position.

1. Place a felt pad and the thread spool on the spool pin and fit a cap of the right size and direction.
Note: Hold thread with both hands to prevent it from slacking while threading. This ensures that the thread will be positioned properly in the threading path.
2. Pull the thread under the thread guide (A) from the right to the left.
3. Pull the thread from the right to left along the slot.
4. Pull the thread between the tension discs (B).
5. Thread down through the right-hand threading slot and then upwards through the left-hand threading slot.
6. Bring the thread from the right into the take-up lever (C) and down in the left-hand threading slot into the needle thread guide (D).
7. Thread the needle.

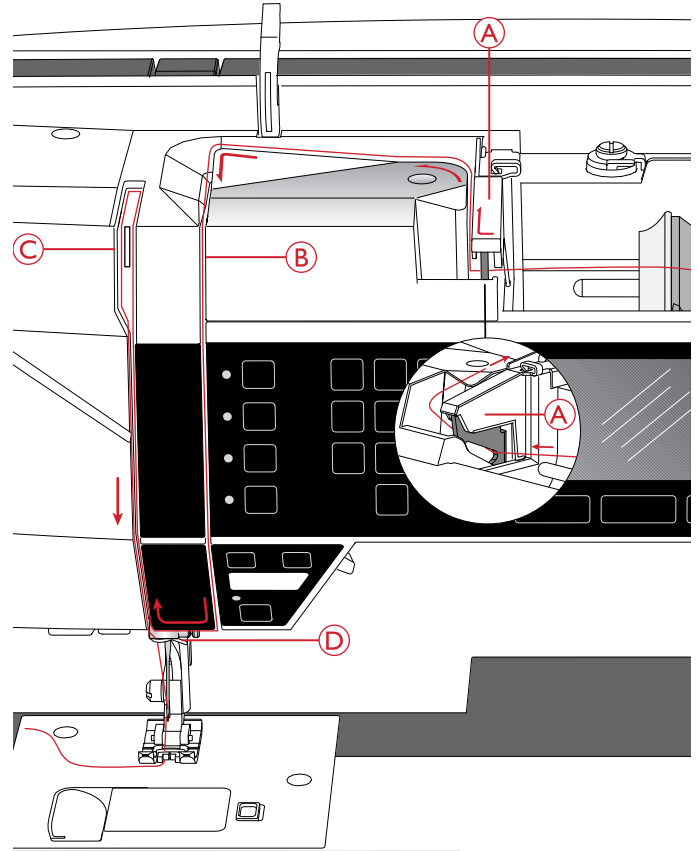

Needle Threader

The needle threader allows you to thread the needle automatically. The needle must be in its highest position to use the built-in needle threader. Press the needle up/ down button to make sure the needle is fully raised.

We also recommend lowering the presser foot.

1. Use the handle (A) to pull the needle threader all the way down. Metal flanges encase the needle and a small hook will pass through the needle eye.
2. Place the thread from the back over the thread guide (B) and under the small hook (C).
3. Let the needle threader gently swing back. The hook pulls the thread through the needle eye and forms a loop behind the needle. Pull the thread loop out behind the needle.
4. Raise the presser foot and place the thread under it.

Note: The needle threader is designed to be used for size 70-120 needles. You cannot use the needle threader for size 60 needles or smaller, wing needles or twin needles.

There are also some optional accessories that require manual threading of the needle.

When threading the needle manually, make sure that the needle is threaded from front to back.

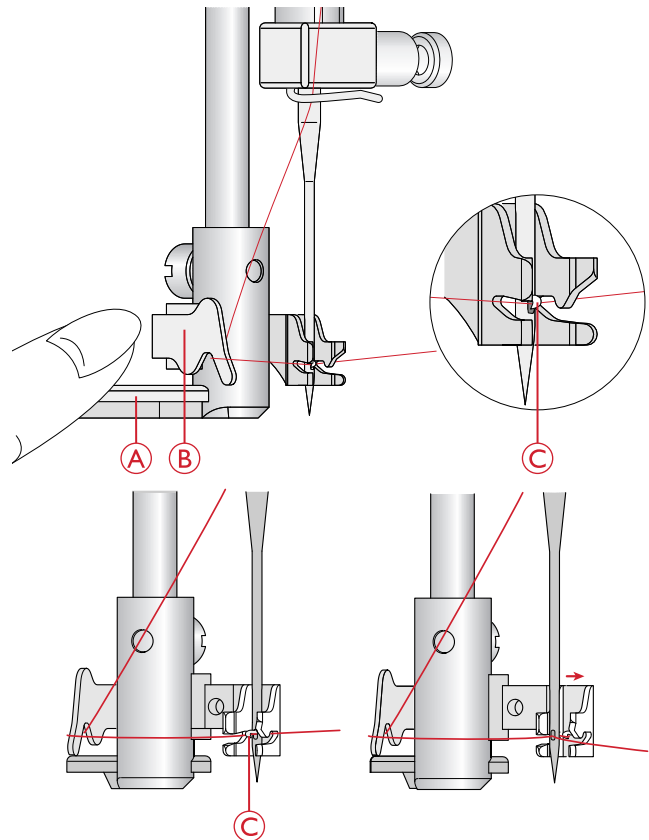

Cutting the Thread

Once you have finished sewing, cut the threads by raising the presser foot and pulling the threads from the front to the back into the thread cutter on the left side of the machine.

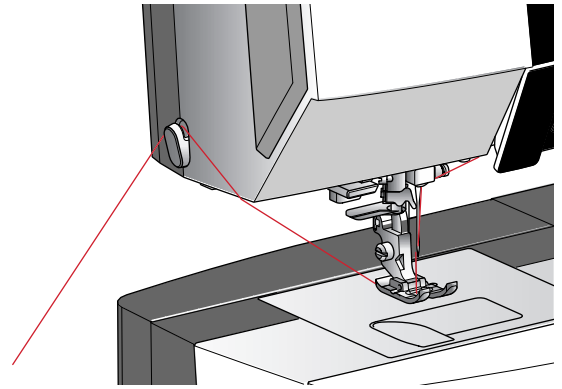

Threading for Twin Needle

Replace the sewing needle with a twin needle. Make sure that the presser foot is raised and the needle is in its highest position.

1. Thread the first thread as described in [Threading the Machine, page 16](#).
2. Thread the needle eye by hand from front to back.
3. Insert the auxiliary spool pin and slide on a felt pad. Place the second thread on the spool pin.
4. Bring thread to the left and pull thread into the thread guide (A) from back to front.
5. Thread the second thread the same way as the first.
6. Make sure that one thread is inside the needle thread guide and the other one outside.
7. Thread needle eye by hand from front to back.

Note: The weight and irregular surface of specialty threads, like metallics, can cause increased tension on the thread. Reducing the tension will prevent needle breakage.

Note: Activate twin needle and select the correct twin needle width in the settings menu. This will limit the width of all stitches for that needle size to prevent damage to presser foot and needle.

Note: Do not use asymmetrical twin needles, since they may damage your sewing machine.

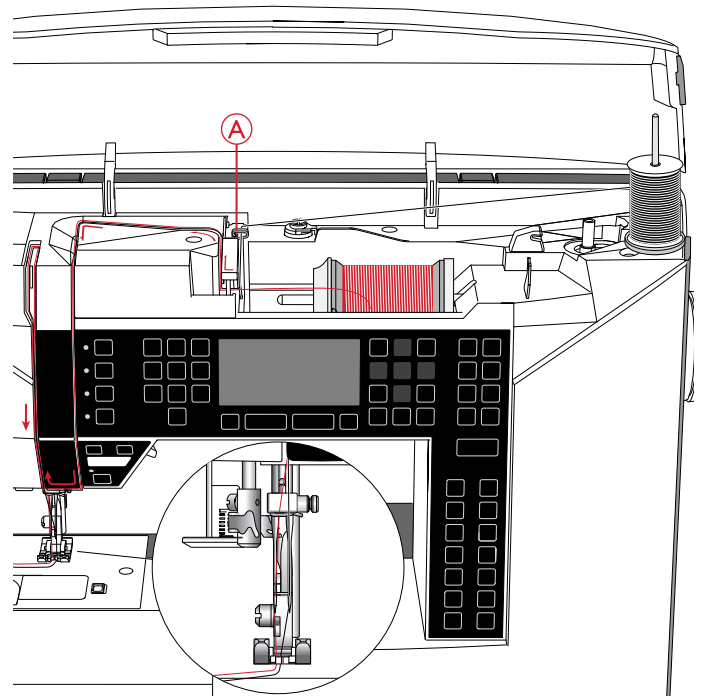

Bobbin Winding

Winding From Horizontal Position

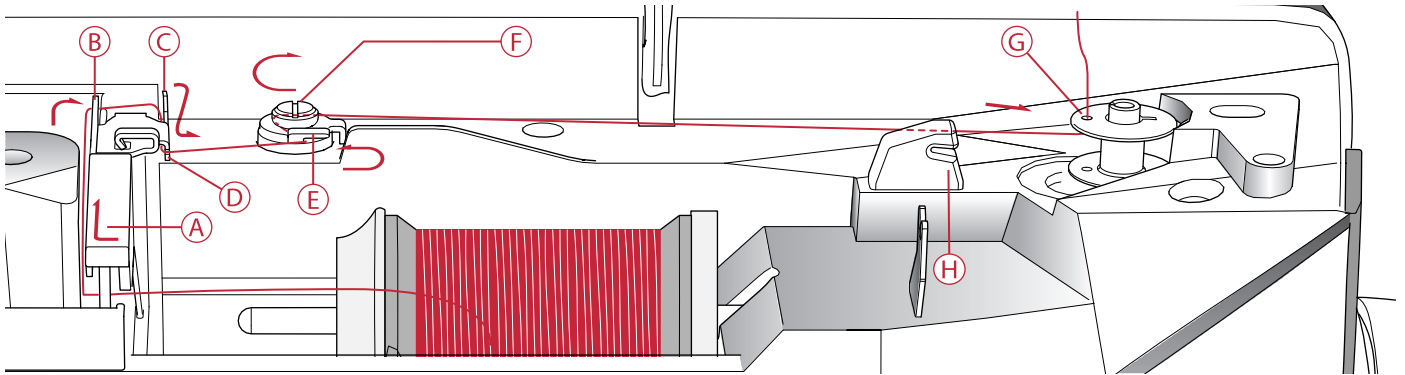

1. Place the felt pad and thread spool on the spool pin in horizontal position. Slide on a spool cap of the right type and direction.
2. Place the thread under the thread guide (A) from right to left. Pull the thread to the rear and around the thread guide (B) from left to right, then around thread guide (C) and into the notch (D).
3. Pull thread to the right and then through the thread guide (E) from front to back. Pass thread under tension disc (F) in clockwise direction.

Note: Make sure the thread is pulled securely inside the tension disc for correct thread tension.

4. Thread through the hole in the empty bobbin (G) from the inside to the outside.
5. Place the bobbin on the bobbin winder spindle.
6. Push the bobbin spindle to the right to wind. A pop-up appears on the screen to inform you that bobbin winding is active. Press the foot control or the start/stop button to start winding the bobbin. Hold the end of the thread firmly when starting to wind.

When the bobbin is full, release the foot control or press the start/stop button again to stop. Push the bobbin spindle to the left. The pop-up closes. Remove the bobbin and cut the thread using the bobbin thread cutter (H).

Note: When winding the bobbin from auxiliary spool pin, do not hook thread to the guide (C) and notch (D).

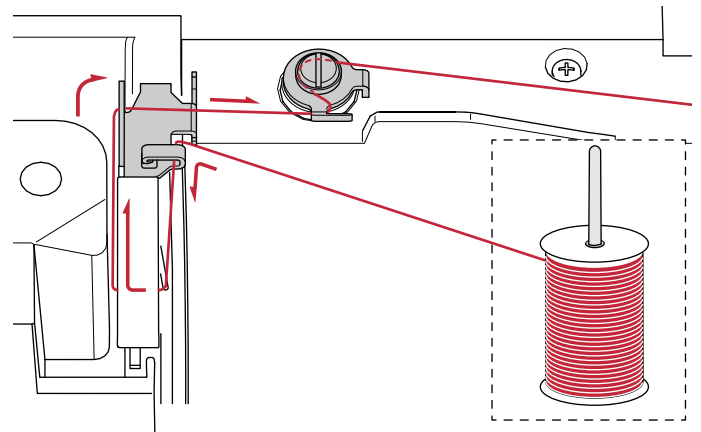
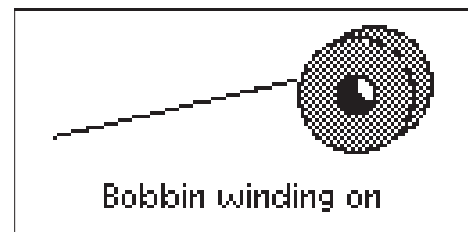
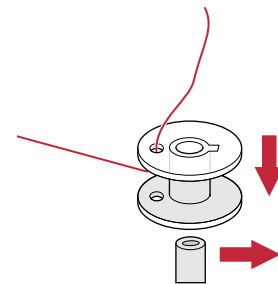
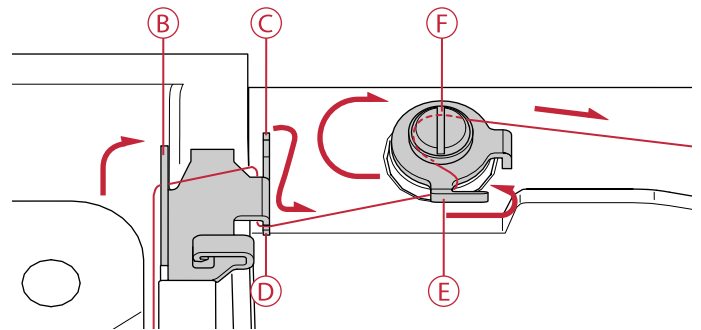

Winding Through the Needle

Make sure the presser foot is raised and the needle is in its highest position.

Note: Use a metal presser foot when bobbin winding from the needle.

Pull the thread from the needle under the presser foot and to the right through the thread guide (A).

Follow step 4–6 under [Winding From Horizontal Position](#).

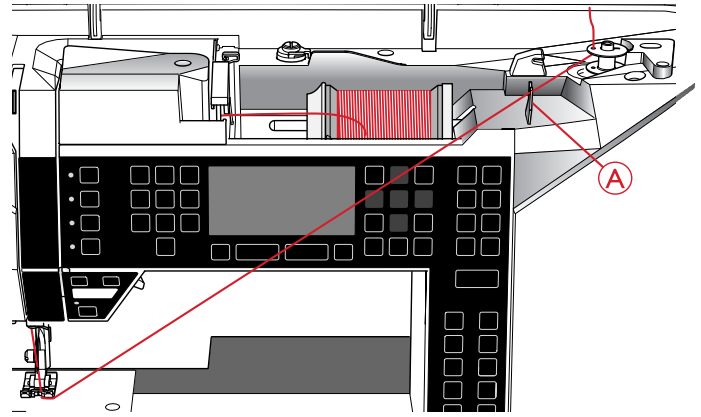

Inserting the Bobbin

Make sure the needle is fully raised and the machine is turned off before inserting or removing the bobbin.

1. Open the bobbin cover by pushing the release button to the right (A). Remove the cover (B).
2. Insert the bobbin in the bobbin case with the thread running in a counterclockwise direction.
3. With a finger held gently on top of the bobbin, pull the thread into notch (C). Then pull the thread at arrow markings into the needle plate thread guide from (C) to (D). Pull the thread at the arrow markings into the needle plate thread guide from (D) to (E). To cut off excess thread, pull thread to the right, over the blade (E).
4. Replace the bobbin cover.

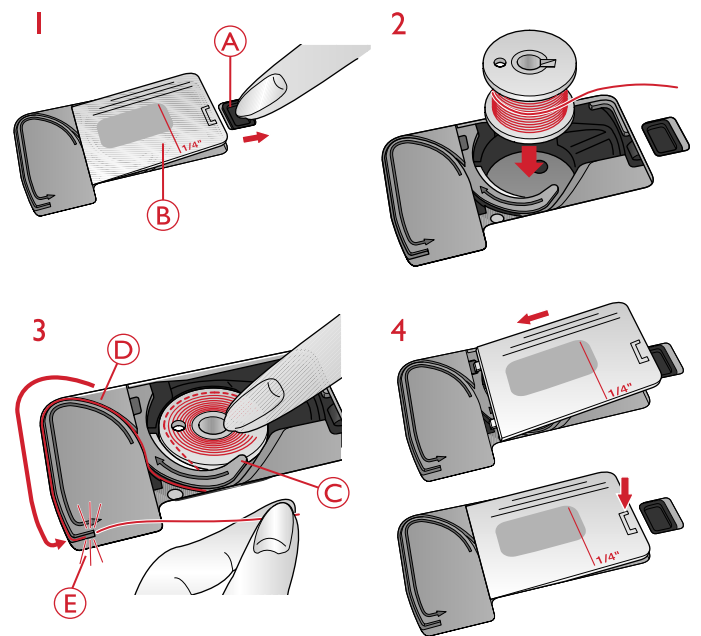

Thread Tension

For the best stitch appearance and durability, make sure the needle thread tension is correctly adjusted, i.e. for general sewing, the threads evenly meet between the two fabric layers. Your sewing machine electronically sets the thread tension for the selected stitch. Depending on the fabric, batting, thread etc, the tension may need to be adjusted. See [page 29](#) for instructions on how to change the setting manually.

If the bobbin thread is visible on the top side of the fabric, the needle thread tension is too tight. Reduce the needle thread tension.

If top thread is visible on the underside of the fabric, the needle thread tension is too loose. Increase the needle thread tension.

For decorative stitches and buttonholes, the top thread should be visible on the underside of the fabric.

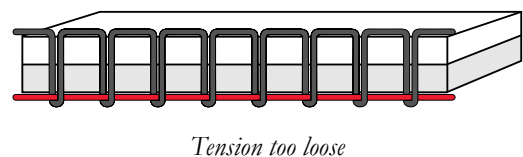
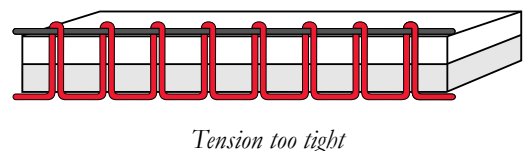
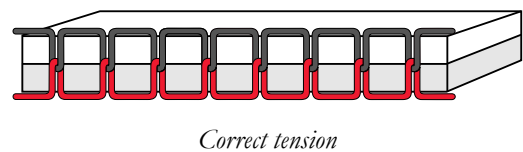

Thread Sensor

If the upper thread breaks, the machine stops and a pop-up message appears on the graphic display.

Re-thread the machine and close the pop-up message by pressing the OK button.

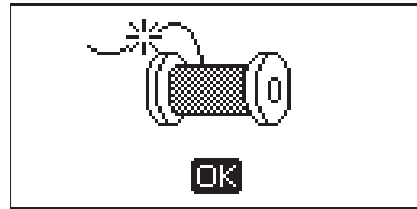

Lowering the Feed Teeth

The feed teeth are lowered when you move the switch on the back of the free arm to the left. Move the switch to the right if you wish to raise the feed teeth. The feed teeth will raise as you begin to sew. The feed teeth should be lowered when sewing on buttons and for free motion sewing.

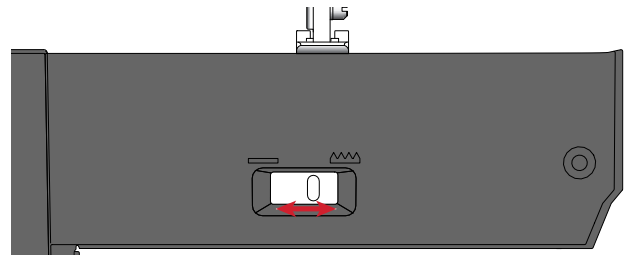

Presser Foot Pressure

The presser foot pressure has been pre-set to the standard value "N". In most cases, you do not need to adjust the presser foot pressure. For specialty techniques, or when sewing on very light or heavy fabric, adjusting the pressure can improve the result. For very light fabrics, turn the dial to a lower number. For heavy fabric, turn the dial to a higher number.

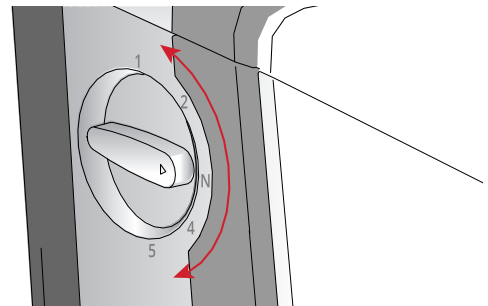

Presser Foot Lift

The presser foot is lowered or raised with the presser foot lift (A). If you are sewing on heavy fabric or several layers of fabric, the presser foot can be raised higher (B) to make it easier to place the fabric underneath the presser foot.

Note: The machine will not start when the presser foot is raised (except for bobbin winding). A pop-up message will tell you to lower the presser foot.

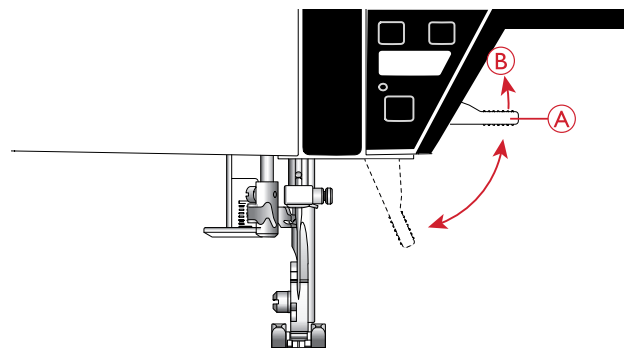

Changing the Presser Foot



Press the ON/OFF switch to "O".

1. Make sure that the presser foot is raised and the needle is in its highest position. Pull the presser foot towards you.
2. Line up the cross pin on the foot with the gap in the presser foot ankle. Push back until the foot snaps into place.

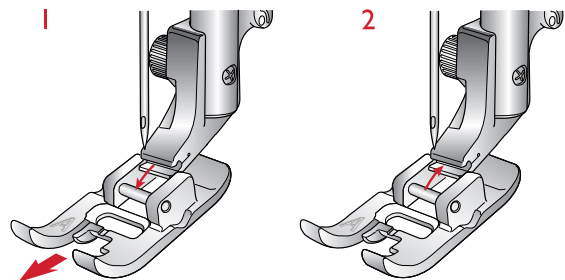

Threads

There are many threads on the market today developed for different purposes.

All purpose sewing thread	All purpose sewing thread is made of synthetic, cotton or cotton covered polyester. This type of thread is used for sewing garments and projects.
Embroidery thread	Embroidery thread is made of various fibers: rayon, polyester, acrylic or metallic. These threads create a smooth glossy appearance for embroidery and other decorative stitching. When embroidering, use embroidery bobbin thread because it is a fine weight and will not build up under embroidery. <i>Note: When using a metallic or a flat film thread for embroidering, you may need to use a needle with a larger eye and lower the embroidery speed. Thread the sewing machine with the spool in the vertical position.</i>
Transparent thread	Transparent thread, also called monofilament thread, is single clear synthetic thread. It is used for quilting and other decorative sewing. Thread the sewing machine with the spool in the vertical position. When winding a bobbin, wind at slow speed and wind the bobbin half full.

Stabilizers

Ensure you use the proper stabilizer for your embroidery technique or fabric type.

Tear-away stabilizers	Tear-away stabilizers are used with stable woven fabrics. Place underneath fabric for decorative stitching or hoop with the fabric when embroidering. Tear away excess stabilizer after stitching.
Iron-on tear-away	Iron-on tear-away is a totally stable stabilizer that has a slick side for ironing on to fabric. It is recommended for knits and all unstable fabrics. Fuse it to the wrong side of the fabric before decorative stitching or hooping. Tear away excess stabilizer after stitching.
Cut-away stabilizer	Cut-away stabilizer does not tear so the excess has to be cut away. It is recommended for knits and all unstable fabrics, especially for hoop embroidery.
Water soluble stabilizer	Water soluble stabilizer is placed on top of the fabric when embellishing/embroidering napped and looped fabrics such as terry cloth. When embroidering cutwork or free standing lace designs, use it underneath the fabric. Place your work in water to dissolve the excess stabilizer. It is available in different thicknesses.
Disintegrating stabilizer	Disintegrating stabilizer is a stable, loosely woven fabric that is used for techniques such as cutwork and to crochet off the fabric edge. The stabilizer disappears with heat.
Sticky stabilizer	Sticky stabilizer is used for hoop embroidery when the fabric is too delicate or too small to be hooped. Hoop the sticky stabilizer with the paper side up. Remove the paper and stick the fabric onto the sticky surface. Tear away sticky stabilizer after stitching.

Needles

The sewing machine needle plays an important role in successful sewing. Use only quality needles. We recommend needles of system 130/705H. The needle package included with your machine contains the most frequently used sizes.

Universal Needle

Universal needles have a slightly rounded point and come in a variety of sizes. For general sewing on a variety of fabric types and weights.

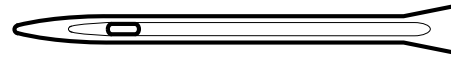

Universal needle.

Stretch Needle

Stretch needles have a special scarf to eliminate skipped stitches when there is a flex in the fabric. For knits, swimwear, fleece, synthetic suedes and leathers.

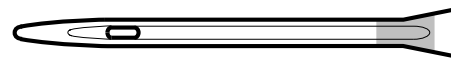

Stretch needle - marked yellow.

Embroidery Needle

Embroidery needles have a special scarf, a slightly rounded point and a slightly larger eye to avoid damage to thread and materials. Use with metallic and other specialty threads for embroidery and decorative sewing.

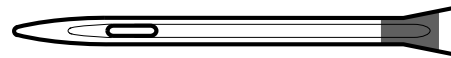

Embroidery needle - marked red.

Denim Needle

Denim needles have a sharp point to penetrate tightly woven fabrics without deflecting the needle. For canvas, denim, microfibers.

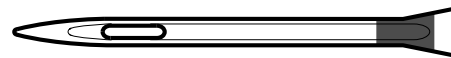

Denim needle —marked blue.

Wing Needle

The wing needle has wide wings on the side of the needle to poke holes in the fabric when sewing entredeux and other hemstitches on natural fiber fabrics.

Note: Wing needle is not included with the machine.

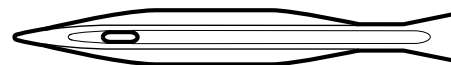

Wing needle.

Important Needle Information

Change the needle often. Always use a straight needle with a sharp point (A).

A damaged needle (B) can cause skipped stitches, breakage or snapping of the thread. It can also damage the needle plate.

Do not use asymmetrical twin needles (C), they can damage your sewing machine.

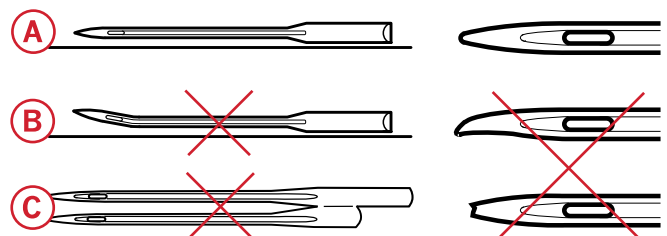

Changing the Needle



Press the ON/OFF switch to "O".

1. Loosen the needle screw with the screwdriver.
2. Remove the needle.
3. Push the new needle upwards with the flat side away from you until it will go no further.
4. Tighten the needle screw with the screwdriver.

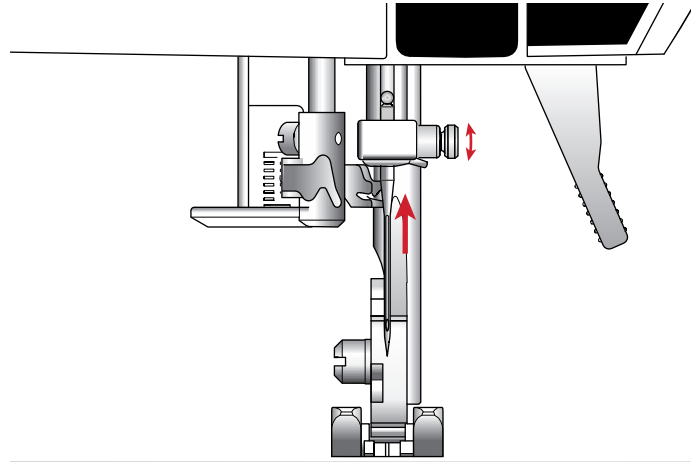

USB Port

Your machine has a USB port to connect your USB embroidery stick.

USB Embroidery Stick

Delivered with your machine is a USB embroidery stick with embroidery designs and HUSQVARNA VIKING® DESIGNER JADE™ 35 sampler book. Use the stick to store designs and embroidery fonts, or to move files between the computer and sewing machine.

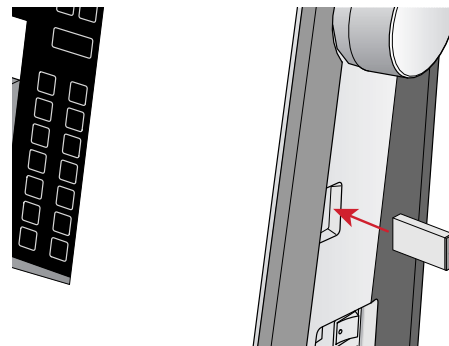

Connect to and Remove From USB Port

Insert the USB embroidery stick in the port with logo facing you. The USB embroidery stick can only be inserted one way – do not force it into the port! To remove, carefully pull the USB embroidery stick out straight.



Do not remove the USB embroidery stick while operating the machine or stitching the embroidery, as this can damage the files on your USB embroidery stick and you will lose all current embroidery design information on screen.

Complimentary Embroidery Intro Software (PC)

A PC embroidery intro software is available for your HUSQVARNA VIKING® DESIGNER JADE™ 35 sewing and embroidery machine.

It adds the following features:

- Allows you to adjust your embroideries on the computer before you sew.
- Personalize your embroideries in true 3D in a real hoop.
- Rotate your embroideries to any degree, mirror them from side to side or end to end and scale or resize your embroideries.
- Adjust an unlimited number of designs and lettering.
- Adjust the colors to the thread shades from your preferred manufacturer. Combine with lettering or shapes. ColorSort to intelligently re-sort the color order of a design and reduce the number of thread changes. Select multiple designs and move them as a group.

How to Update Your Machine

Be sure to consult the web site at www.husqvarnaviking.com and/or your local authorized HUSQVARNA VIKING® dealer for updates and upgrades for your machine and owner's manual.

Updating Instructions

- Go to the HUSQVARNA VIKING® web site at www.husqvarnaviking.com to find information about available updates.
- Follow the update wizard to prepare your USB embroidery stick for the update.
- Insert the prepared USB embroidery stick into the machine before turning it on.
- To start your machine in update mode, press and hold the reverse button and the needle stop up/down button, while turning on your machine. Keep the reverse button and needle stop up/down button pressed until update mode is visible on the graphic display. Follow the instructions to update.

- Add multi-line lettering with your choice of 4 line types and flexibility to resize and space letters individually. Use the QuickFont wizard to create new fonts for the embroidery intro software from most TrueType® or OpenType® fonts on your computer. Add SuperDesigns to your project. Surround lettering or designs with a frame.

Go to HUSQVARNA VIKING® website at www.husqvarnaviking.com and look for support and download the software.

More information and detailed installation instructions are available on a separate PDF file on the USB embroidery stick. A printed product code sheet with your unique product activation code is packed with your machine. Please store your printed product code sheet and the sales receipt for your machine together, they are your proof of ownership for the software. The unique product activation code is needed to activate and use your embroidery intro software.

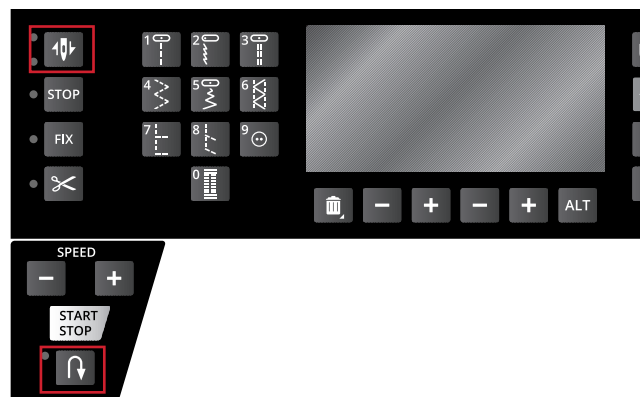

Function Buttons

(Embroidery mode functions are in parenthesis)

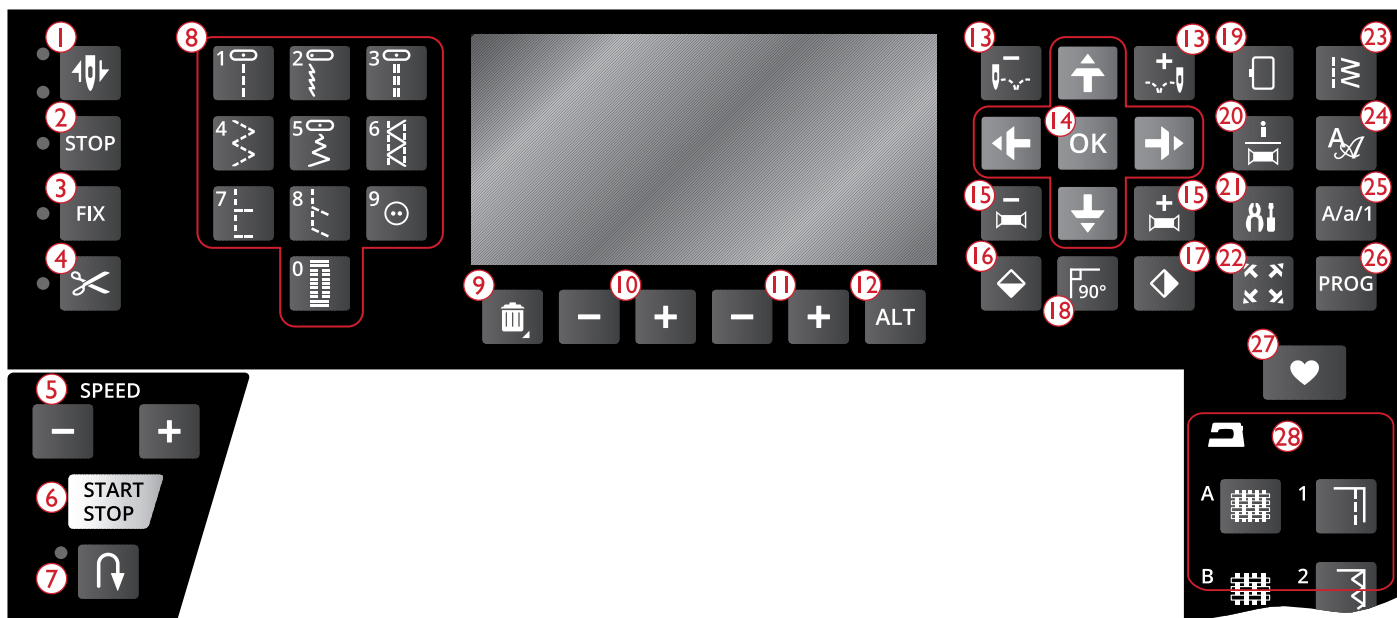

- | | | |
|---|--|--|
| 1. Needle stop up/down with indicator (trim position) | 10. Stitch length/density/elongation and design height | 19. Hoop options |
| 2. STOP function (monochrome) | 11. Stitch width/needle position and design width | 20. Embroidery info button |
| 3. FIX function (baste) | 12. Alternate view | 21. SET menu |
| 4. Cut function | 13. Step stitch by stitch - and + | 22. Corner check |
| 5. Speed + and - | 14. Navigator arrows and OK | 23. Stitch menu/load design |
| 6. Start/stop | 15. Step color by color - and + | 24. Font menu |
| 7. Reverse | 16. Mirror end to end | 25. Shift to upper-case, lower-case or numbers |
| 8. Stitch selection buttons | 17. Mirror side to side | 26. Program mode |
| 9. Delete | 18. Rotate design | 27. Save stitch or program |
| | | 28. Exclusive SEWING ADVISOR™ |

Needle Stop Up/Down With Indicator (Trim Position)

In sewing mode: Press the needle stop up/down to move the needle up or down. The setting of the needle stop position is changed at the same time. The LED indicators next to the button show the selected stop position. The upper indicator is lit when needle stop up is selected and the lower when needle stop down is selected.

You can also tap the foot control to raise or lower the needle.

In embroidery mode: If no hoop is attached, the embroidery unit will move the embroidery arm to park position when you select needle stop up/down. If a hoop is attached, the machine will move the hoop forward, towards you, for easy thread trimming (see [Park Position/Trim Position](#), page 70).

STOP Function (Monochrome)

In sewing mode: STOP is used to conclude a stitch or to sew just one unit of the stitch. Your sewing machine ties off

the thread and stops automatically when one stitch unit or stitch program has been completed. The LED next to the button is lit when STOP is activated. To cancel; select STOP again or select a new stitch. The STOP function is cancelled when the stitch is completed. Press the button again if you wish to activate it again.

STOP is also used to repeat the darning or bartack stitch with the same size.

The STOP function can be programmed, see [Add Commands](#), page 42.

Tip: If you want to repeat the STOP function for a stitch unit several times in a row you can save the stitch with a STOP at the end in a program (see [Add Commands](#), page 42)

In embroidery mode: When embroidering, STOP is automatically activated and the machine stops at color changes. Deselect STOP to eliminate stops for color changes to create monochrome embroidery (see [One-Color Embroidery \(Monochrome\)](#), page 70). The LED next to the button is lit when STOP is activated.

FIX Function (Baste)

In sewing mode: FIX is used to tie off a stitch. FIX is automatically activated when you select a stitch, use the cut function, or use STOP while you are sewing. At the beginning, your machine sews a few tie-off stitches and continues with the selected stitch. Press FIX while sewing and your machine sews a few tie-off stitches and stops automatically. The LED next to the button is lit when FIX is active. Press the FIX button to turn the function off. The FIX function can be programmed, see [Add Commands, page 42](#).

Note: FIX auto can be cancelled in the SET menu (see [FIX Auto \(Only in Sewing Mode\)](#)). No automatic FIX stitches will be sewn unless you use the FIX button on your machine.

In embroidery mode: Press FIX to baste an outline of the embroidery design area or to baste the fabric to the stabilizer.

Cut Function

In sewing mode: Press the cut function button and your machine cuts the top and bobbin threads, raises the needle, and activates the FIX function for the next start. To cut threads at the end of a stitch or stitch program, press the cut function button while sewing. The LED next to the button starts flashing indicating that a cut is requested. When the stitch or stitch program is completed, the machine will make a FIX and then cut the upper thread and bobbin thread.

Note: Your machine cuts the threads automatically after certain stitches such as completing a one-step buttonhole. Cut auto can be deselected in the SET menu, see [CUT Auto \(Only in Sewing Mode\), page 29](#).

If FIX auto has been deselected in the SET menu, the FIX function will not be activated when using the cut function.

In embroidery mode: The cut function button has no function while embroidering. When stopped, press the cut function button and your machine cuts the top and bobbin threads. At the end of a color block or when the design is finished, both top and bobbin threads are cut automatically.

Speed + and –

In sewing mode: All stitches in your machine have a pre-set, recommended sewing speed. Press speed + or speed – to increase or decrease the sewing speed. The speed level is shown on the graphic display. You cannot select a higher speed than the max speed for the selected stitch.

When sewing with metallic threads, or when sewing on delicate fabrics, lower the speed for optimal results.

In embroidery mode: Each stitch type in a design has a pre-set maximum speed at which it can be sewn. To reduce the speed when using specialty threads or embroidering on delicate fabrics, press speed –. To increase the speed again press speed +.

Start/Stop

Press this button to start or stop the machine sewing or embroidering when you are not using the foot control. Press start/stop to begin and press again to stop.

Your machine stops automatically at color changes and when the embroidery is finished.

Reverse

For permanent reverse, press the reverse button once before starting to sew. The reverse indicator will be lit and the machine sews in reverse until you press the button again to cancel. If you press the reverse button while sewing, the machine will sew in reverse for as long as you keep the button pressed. The reverse indicator is lit when the reverse button is pressed.

Reverse is also used when sewing bartacks and darning stitches to step between the parts of the stitch.

Reverse has no function in embroidery mode.

Stitch Selection Buttons

By pressing any of the 0 to 9 buttons you select the stitch illustrated on that button immediately.

By pressing two digits in quick succession you will be able to select a stitch from 10 and up from the selected stitch menu. If the stitch number does not exist in the selected stitch menu you will hear a beep and the first entered digit will be selected as a stitch.

Delete

Press to delete a single stitch or all stitches in a stitch program or embroidery font program.

Stitch Length/Density/Elongation and Design Height

In sewing mode, reduce or increase the stitch length/density by pressing – or +. See [Stitch Length/Stitch Density, page 37](#).

In embroidery mode, reduce or increase the design height by pressing – or +. See [Design Height, page 68](#).

Stitch Width/Needle Position and Design Width

In sewing mode, adjust the stitch width/needle position by pressing – or +. See [Stitch Width, page 37](#) and [Needle Position, page 38](#).

In embroidery mode, reduce or increase the design width by pressing – or +. See [Design Width, page 68](#).

Alternate View (ALT)

When you select a satin stitch, the density setting will be shown on the graphic display. By pressing the alternate view button, the elongation will be shown instead of the density setting.

In embroidery mode, pressing the alternate view button will switch between embroidery edit and embroidery stitch-out view.

Step Stitch by Stitch – and +

In embroidery mode, use the step stitch by stitch – and + buttons to step through the design stitch by stitch.

Navigator Arrows and OK

Make your selections with the navigator arrows and confirm your selections or changes with OK.

Use the left/right navigator arrows to select stitches step by step in numerical order within the selected stitch menu.

Use the up/down navigator arrows to set the number of stitches when sewing on a button.

The navigator arrows are also used when programming to select stitches/letters within the program or to select letters to insert in the program.

In embroidery mode the navigator arrows are also used for positioning the design in the embroidery area.

Step Color by Color – and +

In embroidery mode, use the step color by color – and + buttons to step to the first stitch of the previous or next color.

Mirror End to End

Press to mirror the selected stitch end to end. If pressed in sewing mode for stitch programs, the whole stitch program is mirrored. The change is visible on the graphic display and an icon is shown indicating that mirror end to end is selected.

In embroidery mode, press to mirror the loaded design end to end. An icon is shown indicating that mirror end to end is selected.

Mirror Side to Side

Press to mirror the selected stitch side to side. In straight stitch, with a left needle position, pressing this icon will move the needle from the left to the right symmetrically across the center position. If pressed in sewing mode for stitch programs, the whole stitch program is mirrored. The change is visible on the graphic display and an icon is shown indicating that mirror side to side is selected.

In embroidery mode, press to mirror the loaded design side to side. An icon is shown indicating that mirror side to side is selected.

Rotate Design

Press the rotate button to rotate current design 90 degrees clockwise. See [Rotate and Mirror Design, page 68](#).

Hoop Options

Press the hoop options button to open a list where you can select hoop size and different hoop positions. See [Hoop Options, page 69](#).

Embroidery Info Button

Press this button before loading a design to see information about design size, number of colors and stitches. Press this button with a design loaded to embroidery mode to see design name, number of colors, number of stitches and the color block list. See [Embroidery Information, page 67](#).

SET Menu (Settings Menu)

Press to open the menu for machine settings. Make changes and selections by using the navigator arrows. Press again to exit the SET menu. Read more about the settings made in the SET menu on [page 29](#).

Corner Check

In embroidery mode, press the corner check button to trace the four corners of the design. Each time you press the button the hoop will move to one of the corners. See [Corner Check, page 70](#).

Stitch Menu/Load Design

Press to open the stitch selection menu. Press when the USB embroidery stick is inserted to load a design.

Font Menu

Press to open the font menu to select a font.

Shift to Uppercase, Lowercase or Numbers

Press to shift to lower or upper-case or numbers when programming letters.

Program Mode (PROG)

Press the program mode button to open the mode for programming. Press the button again to exit the program mode.

Save Stitch or Program

Press to save your own personal stitch or stitch program.

Exclusive SEWING ADVISOR™

The Exclusive SEWING ADVISOR™ feature automatically sets the best stitch, stitch length, stitch width, thread tension

and sewing speed for your project. The stitch is displayed on the graphic display with presser foot, needle and presser foot pressure recommendations. Press the symbols for the fabric you are using and the sewing technique you wish to sew (see Exclusive SEWING ADVISOR™, page 35).

SET Menu

You can change the pre-set machine settings and make manual adjustments to the automatic functions in the SET menu. Open the menu by pressing the SET menu button (A) and select the setting you wish to adjust by pressing the up/down arrow buttons (B). To activate the function, use the OK button to place an X in the box. To cancel the function, press the OK button again to leave the box empty. To change the number settings use the right/left arrow buttons (B). Press the SET menu button again to exit the SET menu.

Note: When a number is set to default the figures will be black. If you change the number the figures will be inverted on a black background.

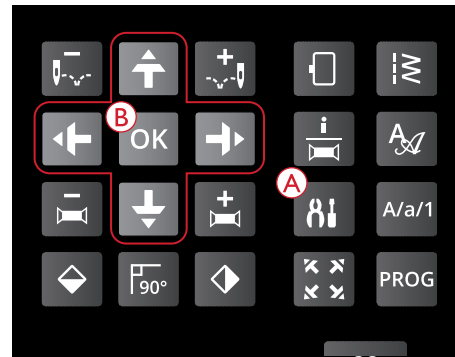

Thread Tension

Your machine will automatically set the best thread tension for the selected stitch and fabric. Use the left/right arrow buttons if you need to adjust the thread tension.

In sewing mode the changes only affect the selected stitch. If another stitch is selected or the same stitch is selected again, the value is reset to the default value. In embroidery mode the value is reset to the default value when a new design is loaded. The setting will go back to default when the machine is turned off.

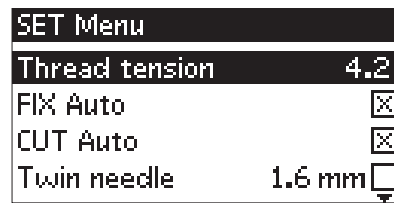

SET menu, sewing mode

FIX Auto (Only in Sewing Mode)

Use the OK button to turn on or off the automatic FIX function in the beginning of each stitch. Your setting will be saved even when the machine is turned off.

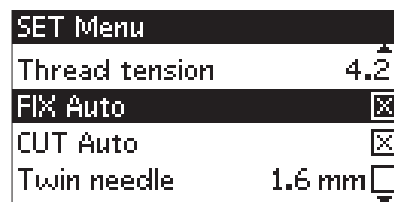

SET menu, sewing mode

CUT Auto (Only in Sewing Mode)

Use the OK button to turn on or off automatic cut after certain stitches such as completing a one-step buttonhole. Your setting will be saved even when the machine is turned off.

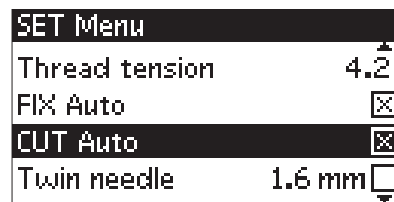

SET menu, sewing mode

Automatic Stop for Cut (Only in Embroidery Mode)

When starting to embroider the machine stops after a few stitches asking you to cut the thread end. Use the OK button to turn on or off the function.

Note: The automatic stop for cut function is disabled if you use the foot control when embroidering.

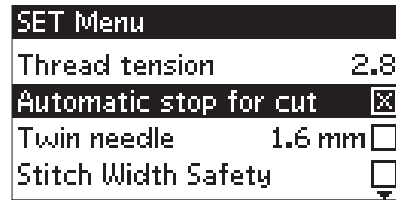

SET menu, embroidery mode

Twin Needle

If you are using a twin needle, set the size of the needle to limit the width of all stitches and prevent needle breakage. Activate or deactivate the twin needle function with the OK button and use the left/right arrow buttons to set the twin needle size. Your setting will be saved even when the machine is turned off. A pop-up message reminds you of the setting when you turn on the machine. Close the pop-up message by pressing OK.

Note: You cannot set the twin needle size if the stitch width safety is on, or turn on the stitch width safety if the machine is set for twin needle.

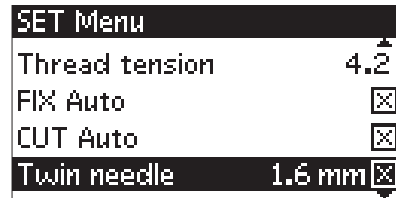

SET menu, sewing mode

Stitch Width Safety

Use the OK button to turn on the stitch width safety when using a straight stitch needle plate or a straight stitch presser foot. The stitch width will be limited to zero for all stitches to prevent damage to the needle, presser foot and needle plate. This setting is saved when the machine is turned off. A pop-up message reminds you of the setting when you turn on the machine. Close the pop-up message by pressing OK.

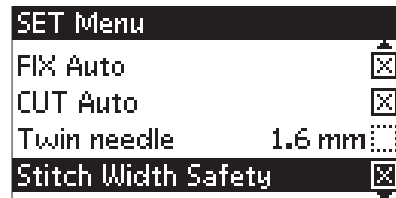

SET menu, sewing mode

Audible Alarm

Turns on or off all alarm sounds of the machine. Default setting is on. This setting is saved even if the machine is turned off.

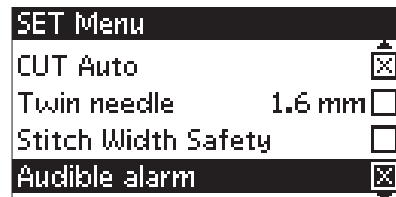

SET menu, sewing mode

Contrast

Adjust the contrast of the graphic display by using the left/right arrow buttons. The value can be set between -3 and 4 in increments of 1. The setting is saved even when the machine is turned off.

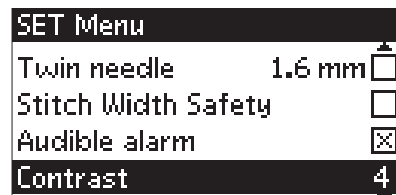

SET menu, sewing mode

Language

Use the left/right arrow buttons to change the language of all text in your machine. The language setting is saved even when the machine is turned off.

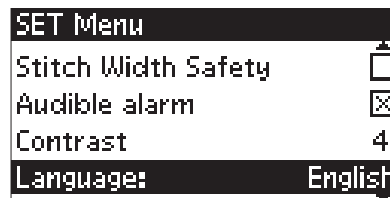

SET menu, sewing mode

Software Version

The currently loaded software version for the sewing machine is displayed.

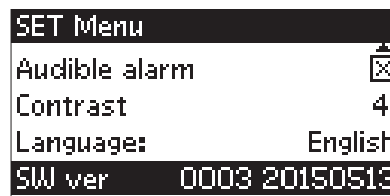

SET menu, sewing mode

3 Sewing Mode

Sewing mode is the first view on the display after you turn on the machine without the embroidery unit connected. Here you will find the basic information you need to start sewing. This is also where you adjust the settings of your stitch. Straight stitch is selected by default.

Sewing Mode Overview

1. Recommended needle for the selected fabric, in this case a universal 80 needle. If "Str" is shown, stretch needle is recommended.
2. The number of the selected stitch.
3. Recommended presser foot for the selected stitch and fabric.
4. Sewing speed indicated by five levels. Reduce or increase the speed by pressing speed + or speed - (see [Speed + and -](#), page 26).
5. Stitch length. Reduce or increase the stitch length by pressing - or +(A) (see [Stitch Length/Stitch Density](#), page 37).
6. Needle position is shown instead of stitch width when straight stitch is selected. Change the needle position by pressing - or + (B) (see [Needle Position](#), page 38)
7. The selected stitch illustrated.
8. The fabric and sewing technique selected on the Exclusive SEWING ADVISOR™ feature (see [Exclusive SEWING ADVISOR™](#), page 35).
9. Recommended presser foot pressure.
10. Thread tension (see [Thread Tension](#), page 29)
11. Twin needle, width 2.0mm is set.
12. Indicates that the function mirror end to end is activated.
13. Indicates that the function mirror side to side is activated.
14. Stitch width. Reduce or increase the stitch width by pressing - or + (B) (see [Stitch Width](#), page 37). When straight stitch is selected, needle position is shown instead of stitch width. (23)
15. Recommendation to use stabilizer under your fabric.

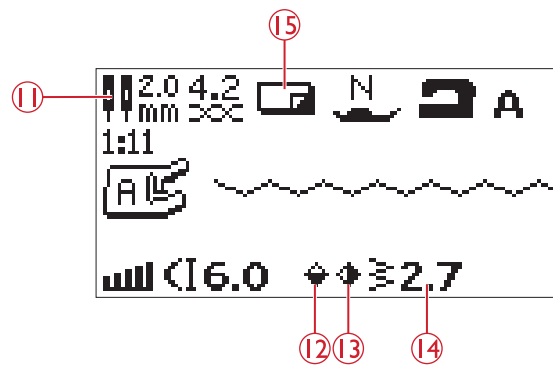
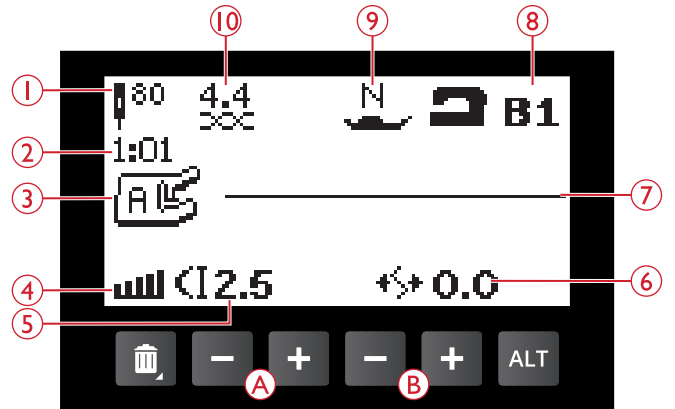

- 16. Recommendation to remove presser foot when sewing on buttons.
- 17. Recommendation to lower the feed teeth is shown when sewing on buttons is selected.
- 18. Recommendation to use the multipurpose tool/button reed (optional accessory, part number 4131056-01) when sewing on a button.
- 19. Set the number of stitches to sew on the button by pressing the up and down navigator arrows (C).

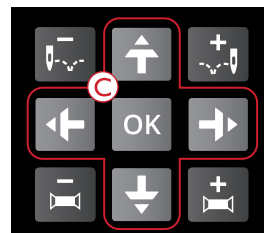
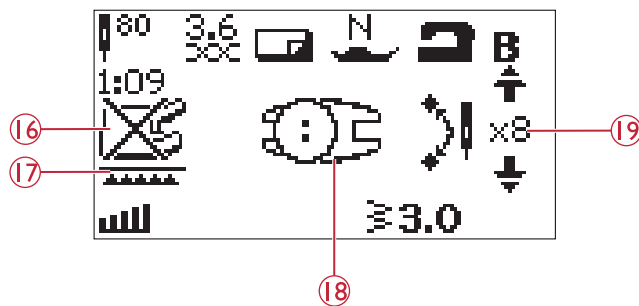

- 20. Stitch density is shown instead of stitch length when a satin stitch, buttonhole, bartack or darning stitch is selected. Reduce or increase the stitch density by pressing stitch length – and + (A).
- 21. Recommendation for corded buttonhole. When sewing buttonholes in stretch fabric, we recommend to cord the buttonhole for better durability, see [Corded Buttonhole \(Stretch Fabrics\)](#), page 54.

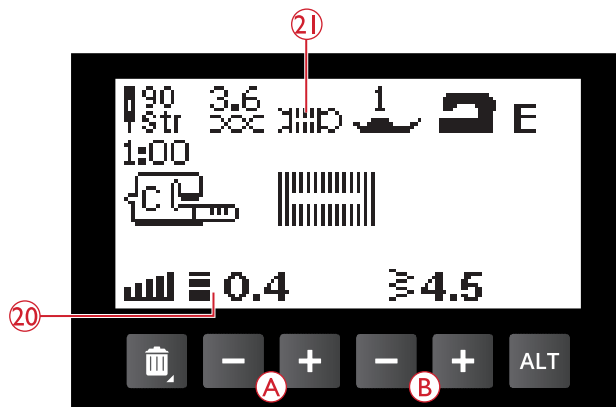

- 22. Elongation is shown instead of density if alternate view button is pressed when a satin stitch is selected. Reduce or increase the elongation by pressing the + or – (A).
- 23. Recommendation to use self adhesive glide plates (see [Presser Feet](#), page 9).
- 24. When sewing a darning or bartack program, the reverse icon is shown to indicate that you need to press reverse when the darning or bartack stitch is sewn to the desired length.

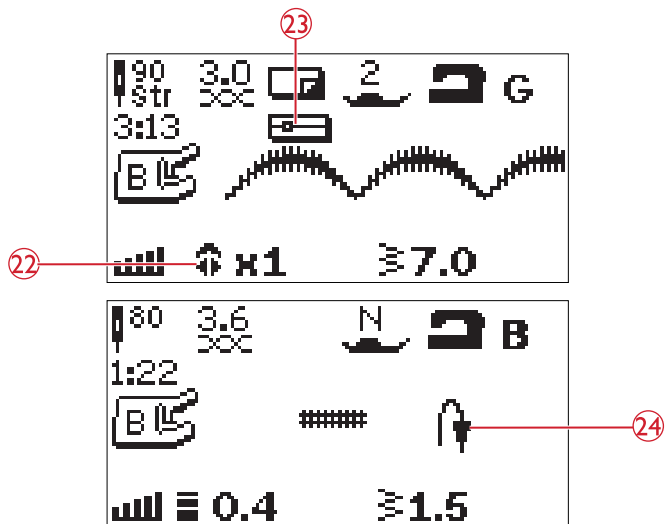

Selecting a Stitch

Press the stitch menu button (D) to select a stitch menu. Use the arrow buttons to select among the menus:

1. Utility stitches
2. Quilt stitches
3. Satin and heirloom stitches
4. Decorative stitches
5. Saved stitch or program

The stitches are pictured inside the lid of your machine with the menu numbers on the left and the stitch numbers within the menus across the center.

When you have selected the menu, press the number of the stitch you wish to use with the stitch selection buttons, or press OK and the first stitch in the selected menu will be selected (stitch number 10). Press the stitch menu button again to close the selection menu without making any selection.

Stitches 0-9 are the same in all stitch menus. If you press any of the stitch selection buttons once, you select the stitch illustrated on that button immediately, regardless of the selected stitch menu.

By pressing two digits in quick succession you will be able to select a stitch from 10 and up from the selected stitch menu. If the stitch number does not exist in the menu you will hear a beep and the first entered digit will be selected as a stitch.

The selected stitch menu, stitch and stitch number will be visible on the graphic display in sewing mode. To select another stitch in the same menu just press the number of the stitch or use the left and right arrow buttons to step stitch by stitch in numerical order. To select a stitch in another menu you will first need to change stitch menu and then select the stitch.

Selecting a Font

Press the font menu button (E) to open the font menu on the graphic display. Use the arrow buttons to select among the fonts: Block or Cyrillic alphabet.

Press the OK button. This automatically opens the mode for programming letters, see [Add Letters, page 41](#).

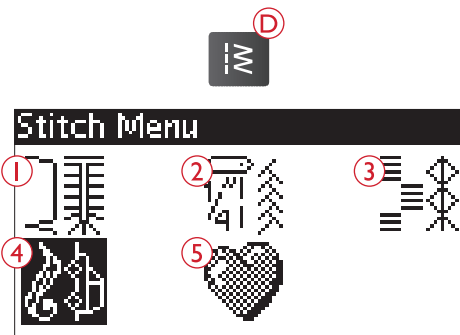

Exclusive SEWING ADVISOR™

Your sewing machine has the HUSQVARNA VIKING® Exclusive SEWING ADVISOR™ feature. The Exclusive SEWING ADVISOR™ feature automatically sets the best stitch, stitch length, stitch width and thread tension for your project. The stitch is displayed on the graphic display with presser foot, presser foot pressure and needle recommendations.

Press the buttons for fabric type and sewing technique desired.

Note: If an unsuitable combination is selected (for example woven light-blind hem), the machine beeps and the technique remains unselected.

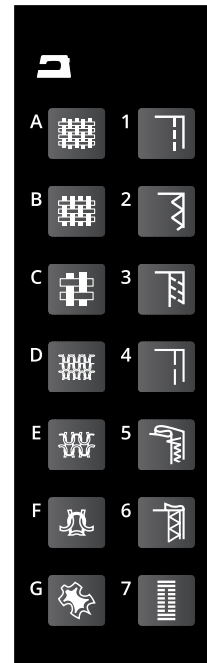

Fabric Selection

Woven or Stretch (Knit)

The difference between woven and knit fabric is the way the threads are put together. Woven fabrics are made of two thread systems, warp lengthwise and weft crosswise, that intersect at right angles. A knit fabric is made of one thread system with interlaced stitches. A knit fabric usually has stretch.

As a general rule, enter Woven for stable fabrics that have no stretch and Stretch for fabrics that have stretch.

- A. **Woven light:** Chiffon, organza, batiste, challis, crepe de chine etc.
- B. **Woven medium:** Calico, quilting fabrics, crepe, broadcloth, velvet etc.
- C. **Woven heavy:** Denim, tweed, canvas, terrycloth etc.
- D. **Stretch light:** Tricot, single knit jerseys etc.
- E. **Stretch medium:** Sweater knits, double knit, velour, swimwear etc.
- F. **Stretch heavy:** Sweater knits, fleece etc.

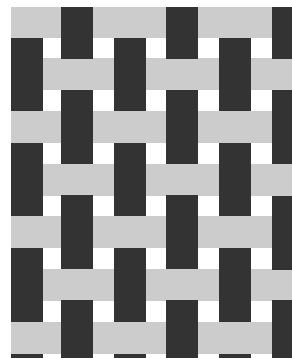

Woven fabric

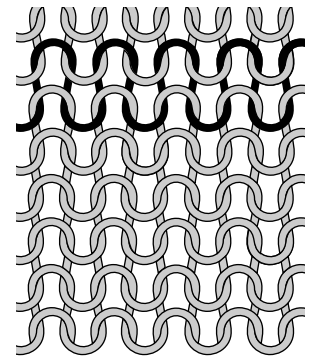

Stretch (knit) fabric

Leather and Vinyl

Leather is animal skin with the coat (fur) removed. Leather can be smooth or sueded and has some give.

Vinyl is a synthetic material which often has a woven wrong side. Vinyl can be smooth or patterned and some vinyls have stretch.

G. **Leather and vinyl:** Suede and leather, vinyl, faux leather and faux suede.

When selected, the Non-Stick Glide Foot H (optional accessory, part number 4127961-45) is recommended for utility sewing. For decorative stitches and buttonholes, the Exclusive SEWING ADVISOR™ feature recommends the use of self-adhesive glide plates (see [Self-Adhesive Glide Plate, page 9](#)).

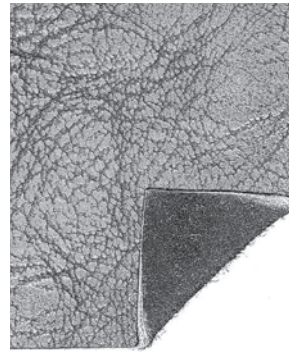

Leather

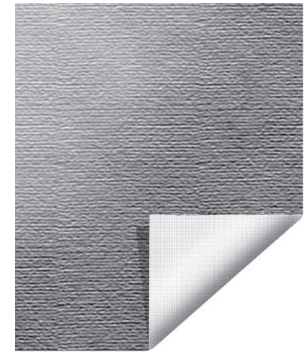

Vinyl

Sewing Techniques

1. **Seam:** sews two pieces of fabric together.
2. **Overcast:** finish fabric edges to prevent them from fraying and help them lay flat.
3. **Seam/overcast:** sews the seam and overcasts the edge all at one time.
4. **Baste:** a temporary stitching for fitting garments, gathering and marking. The Exclusive SEWING ADVISOR™ feature automatically sets a long stitch length and reduces the tension so the threads are easy to remove or to pull for gathering.
5. **Blind hem:** creates an invisible hem on garments. Is not recommended for light weight fabric or for leather/vinyl.
6. **Hem:** selects the best visible or top stitch hem for your fabric type and weight.
7. **Buttonhole:** the Exclusive SEWING ADVISOR™ feature selects the best buttonhole possible for your fabric.

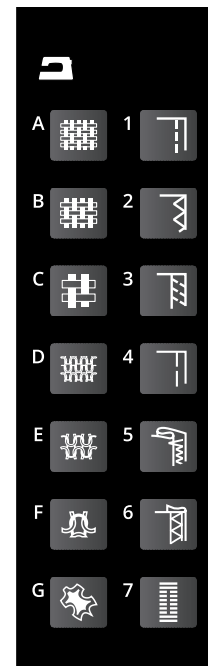

Stitch Settings

Your machine automatically sets the best settings for the selected stitch. The settings are visible on the graphic display. You can make your own adjustments on the selected stitch using the + or – buttons below the settings.

The setting changes only affect the selected stitch. Your changed settings will be reset to default when selecting another stitch. The changed settings are not automatically saved when turning your machine off. You can save the adjusted stitch to the machine memory, see [Save a Stitch or a Program, page 44](#).

Note: When the number for stitch length/width/density or needle position is set to default the figures will be black. If you change the number, the numbers will be inverted on a black background. When trying to exceed minimum or maximum settings a beep will be heard.

Stitch Length/Stitch Density

Increase or decrease the stitch length using the + or – button (A).

When a satin stitch, buttonhole, darning or bartack is selected, the icon changes to show that stitch density is active instead of stitch length. Use the + and – buttons to change the stitch density.

Note: This is often used with specialty threads and when a less dense satin stitch is desired.

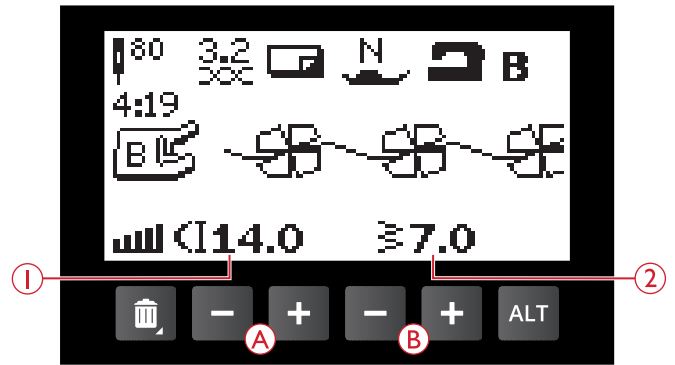

1. Stitch length
2. Stitch width

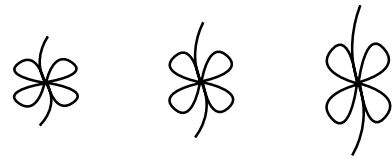

Stitch length – / default stitch length / stitch length +

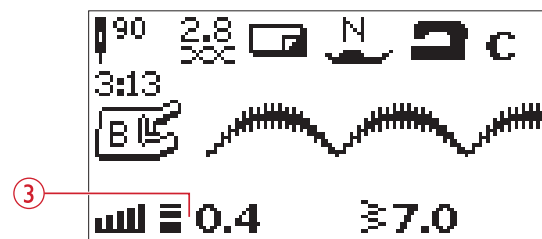

3. Stitch density



Stitch density – / default stitch density / stitch density +

Stitch Width

Increase or decrease the stitch width using the + or – button (B).

Elongation

Elongation is used to lengthen satin stitches. The entire stitch will be longer but the density will remain the same. When a satin stitch is selected, press the alternate view button (C) to show the elongation setting. Use the + and – buttons (A) to change the setting. If elongation is not available for the selected stitch, a warning sound will be heard when pressing the alternate view button and the icon will not change.

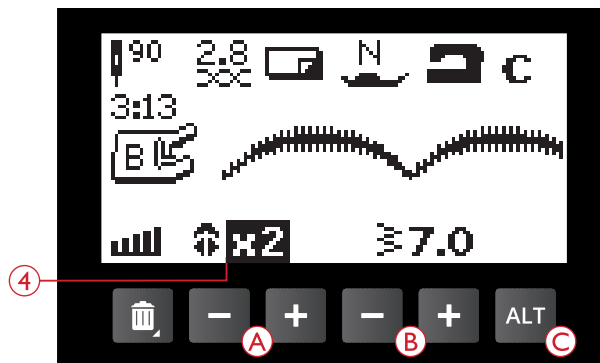

4. Elongation



Needle Position

If a straight stitch is selected the needle position is shown on the graphic display instead of the stitch width. The + and – buttons (B) are used to move the needle to the left or right in 29 positions.

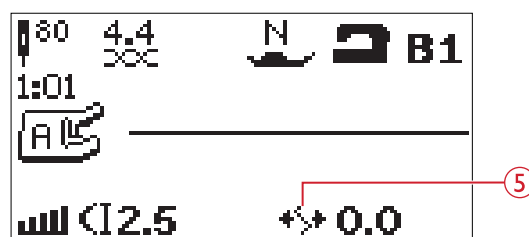

5. Needle position

Mirroring

Mirror End to End

Press the mirror end to end button (A) to mirror the selected stitch end to end. If the button is pressed in sew out mode for stitch programs, the whole stitch program is mirrored. The change is visible on the graphic display and an icon is shown indicating that mirror end to end is activated.

Note: If a stitch cannot be mirrored a beep will be heard when pressing the mirror end to end button.

Mirror Side to Side

Press the mirror side to side button (B) to mirror the selected stitch side to side. If the button is pressed when the straight stitch with left needle position is selected, the needle position is changed from left to right. If the button is pressed in sew out mode for stitch programs, the whole stitch program is mirrored. The change is visible on the graphic display and an icon is shown indicating that mirror side to side is activated.

Note: If a stitch cannot be mirrored a beep will be heard when pressing the mirror side to side button.

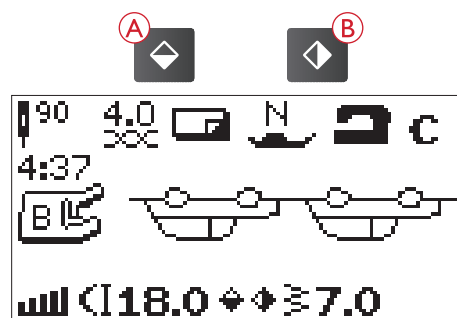

Sewing Pop-Up Messages

Raise Needle

Some functions are only possible with the needle raised. When trying to perform these functions with the needle lowered this pop-up message is shown. Raise the needle and press the OK button to close the pop-up message.

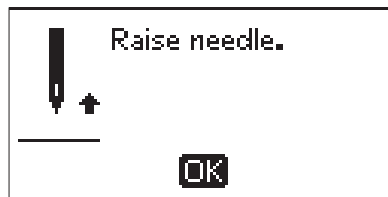

Please Lower the Presser Foot

Your machine will not sew if the presser foot is raised. Lower the presser foot and press the OK button to close the pop-up message.



Machine Set for Twin Needle

When you have set the machine for twin needle in the SET menu, a pop-up message is shown to remind you of the setting when you turn on your machine. Press the OK button to close the pop-up message.

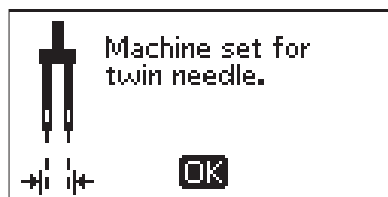

Stitch Width Limited for Twin Needle

This message is shown when the machine is set for twin needle and you try to adjust the stitch width to wider than possible with the twin needle. Close the pop-up message by pressing the OK button.

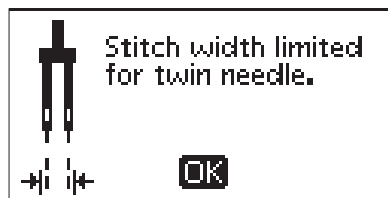

This Stitch Cannot Be Sewn With Twin Needle

This pop-up message appears when the machine is set for twin needle and you select a stitch that cannot be sewn with twin needle. Press the OK button to close the pop-up.

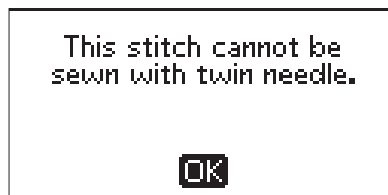

Machine Set for Straight Stitch

This message is shown when the stitch width safety is on and you turn on the machine or try to adjust the stitch width or stitch position. Close the pop-up message by pressing the OK button.

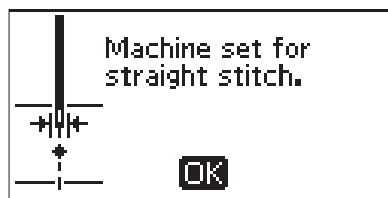

This Stitch Cannot Be Sewn With Stitch Width Safety on

This pop-up message appears when the machine is set for stitch width safety and you select a stitch that is wider than 0 mm.



Remove Any Thread From Under Stitch Plate and in Bobbin Area

When this pop-up appears you need to clean the area under the stitch plate from thread and lint in order for the cut function to cut properly. Close the pop-up message by pressing the OK button.

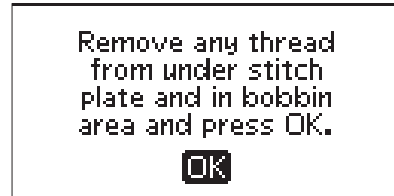

Check Upper Thread

Your machine stops automatically if the top thread runs out or breaks. Re-thread the top thread and close the pop-up message by pressing the OK button.

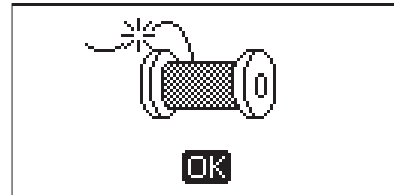

Machine Needs to Rest

If you are sewing on very heavy fabric or if the machine is blocked when sewing, the main motor can get overloaded. The pop-up message will close when the main motor and power supply is secure.

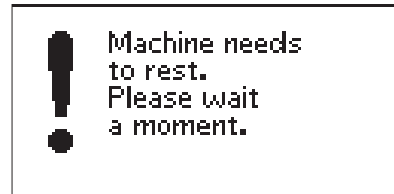

Overwrite?

If there is already a stitch or program saved in the machine memory and you press the save button this message will appear asking if you wish to overwrite the previously saved stitch/program with the new one. Select yes or no with the arrow buttons and press the OK button.

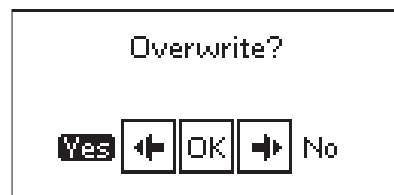

4 Program

The programming function on your machine allows you to create a stitch with your own personal settings and to combine stitches and letters into stitch programs. You can add up to 60 stitches and letters in the same program. Save your own stitch or program in the machine memory and recall it any time you like.

All stitches in your sewing machine are programmable except for buttonholes, darning stitches, button sewing and bartacks.



Create a Stitch Program

1. Press the program mode button (D) to open programming.
2. The stitch menu which was previously selected will be kept when entering the programming mode. To change the stitch menu, press the stitch menu button (A) and select another stitch menu by using the arrow buttons.
3. Press the number of the stitch you wish to use. The stitch will appear in programming mode.
4. Press the number of the next stitch and it will appear to the right of the last entered stitch.

Note: The number above the stitch program on the left side of the graphic display is the number of the selected stitch. Two numbers are displayed above the stitch program on the center of the graphic display. The first number is the position of the selected stitch in the program. The second number, put in parenthesis, is the total number of stitches in the program.

Add Letters

5. Press the font menu button (B). Use the arrow buttons to select a font and press OK. The machine will show the upper case alphabet in programming mode.
6. Use the arrow buttons to select a letter and press OK to add the letter to the program.
7. To switch to a lower case alphabet or numbers press the shift button (C).

About Programming Letters

Both upper and lower case letters will be stitched with a 7 mm stitch width. If there are letters going below the baseline included in the program (e.g. j, p, y) the height of the uppercase letters will be reduced.

All text to be sewn out on the same project, should be in the same program to ensure the letters are sewn out in the same height.

For instance, a name and an address should be in the same program with a STOP after the name.

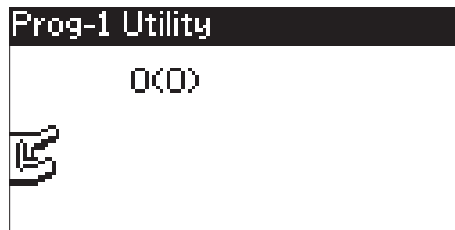

Program mode

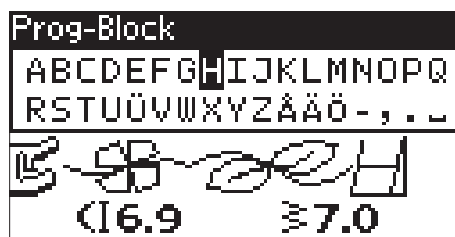
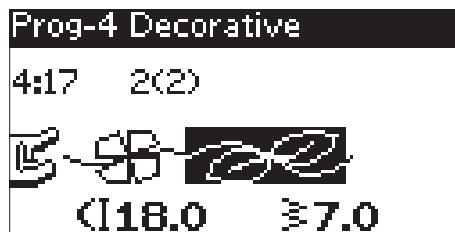

Husqvarna VIKING

Husqvarna VIKING

Above: "Husqvarna" and "VIKING" have been programmed separately.

Below: "Husqvarna" and "VIKING" are in the same program.

Add Stitches or Letters at Other Positions

If you wish to add a stitch or letter at another position in the program, move the cursor by pressing the arrow buttons. The stitch or letter will be inserted to the right of the cursor.

Note: When programming letters, press the arrow down button to activate the cursor in the stitch program instead of in the alphabet.

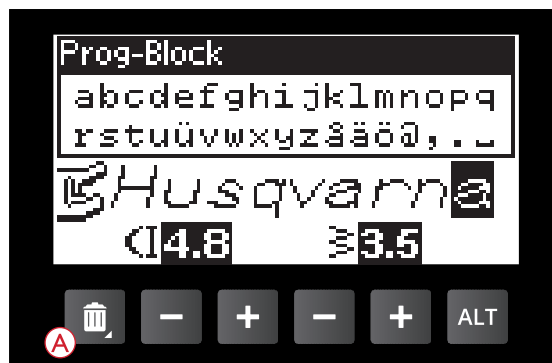

Add the Same Stitch Several Times

If you want to add the same stitch several times in a row you can just press the OK button directly after the first stitch has been inserted. The same stitch will be inserted each time you press OK.

You can also move the cursor to select another stitch and press the OK button. The selected stitch will be inserted once more to the right of the selected stitch.

Delete Stitches or Letters

To delete a stitch in the program, select the stitch with the cursor by pressing the arrow buttons and press the delete button (A).

To delete the whole program, move the cursor to the left of the first position and press the delete button or press and hold on the delete button at any position in the program. A pop-up will appear asking you to verify the deletion. Select yes or no with the arrow buttons and press OK.

Add Commands

The commands FIX and STOP can be added to the program. Each command takes one memory space in the program.

Note: If FIX Auto is activated on your machine, you do not need to add a FIX in the beginning of the program.



Join Two Stitch Programs Into One

You can add a previously saved program to a new one in programming mode. Press the stitch menu button, select the heart symbol (saved stitch or program). Press OK and the program will be inserted in programming mode to the right of the cursor.

Adjust a Single Stitch or Letter

To adjust the settings of a single stitch in a program you must select the stitch in programming mode. You can adjust the stitch width, stitch length, density, needle position or mirror the stitch. The settings for the selected stitch are shown on the graphic display. Press the alternate view button to toggle between different settings.



Adjust the Entire Stitch Program

Adjustments that affect the whole program and not just single stitches, are done in sewing mode. Press the program mode button, Start/Stop button or step on the foot control to leave programming mode and switch to sewing mode. In sewing mode you can adjust the width and length or mirror the whole program.

There are a few things you need to know when adjusting the stitch program in sewing mode:

The adjustments you make to the program in sewing mode can be saved in the machine memory. However, these adjustments cannot be brought back to programming mode. If you have made adjustments in sewing mode and press the program mode button to go back to programming mode, these adjustments will be cancelled. This will also happen if you load a saved program from the machine memory to programming mode.

Sew out the Stitch Program

When you are done with your program press the save button to save it or, if still in programming mode, press the program mode button, start/stop button or step on the foot control to switch to sewing mode.

Once you are in sewing mode and step on the foot control the machine will sew out your stitch program. The program will be sewn continuously if no STOP is programmed. Press the STOP button to sew your stitch program only once.

It is possible to start sewing at any stitch in the program. Use the left/right arrow buttons to step through the program in sewing mode.

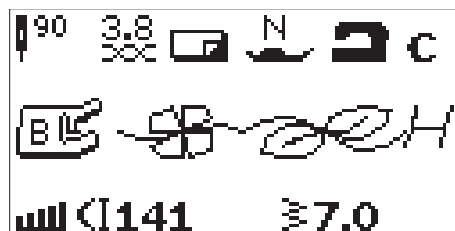

Sewing mode

Machine Memory

You can save and recall your program or favorite stitch with personal settings in the machine memory.

The memory has a maximum space of 60 stitches.

Save a Stitch or a Program

Press the save button (A) from programming or sewing mode. If the memory is not empty, a pop-up message will appear asking if you wish to overwrite the previously saved stitch/program with the new one. Select yes or no with the arrow buttons and press the OK button.

A pop-up message will confirm when program or stitch is saved.

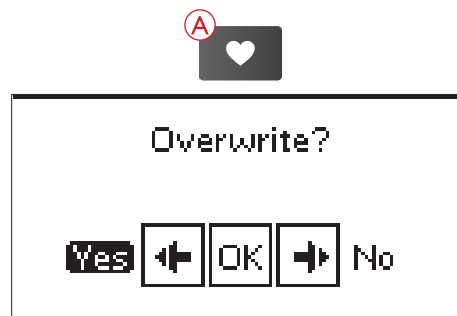

Load a Saved Stitch or Program

To load a saved stitch or program from the machine memory, press the stitch menu button and select the heart symbol (saved stitch or program). The stitch/program will appear in sewing mode ready to be sewn.

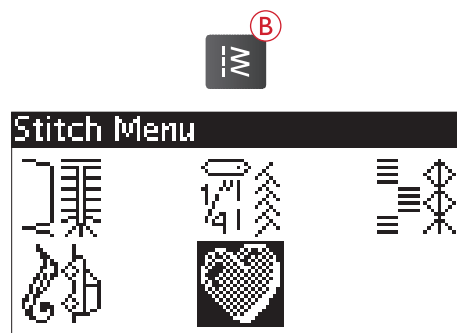

Program Pop-Up Messages

The Stitch Cannot Be Programmed

This message is shown if you try to program or add a buttonhole, bartack, darning stitch or the sew-on-button stitch to a program. All stitches in your sewing machine are programmable except for these. Close the pop-up message by pressing the OK button.



The Stitch Cannot Be Saved

This message is shown if you try to save a buttonhole, bartack, darning stitch or the sew-on-button stitch to the machine memory. All stitches in your machine can be saved except for these. Close the pop-up message by pressing the OK button.



Program Too Long to Add More Stitches

If you try to add more than 60 stitches or letters in the program this message is shown. Close the pop-up message by pressing the OK button.

Note: If you add a FIX or STOP to the program these will each use one memory space in the program.

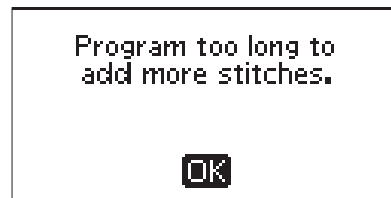

Delete program?

This pop-up message will ask you to confirm when you have chosen to delete an entire program in programming mode. Select yes or no with the arrow buttons and press OK.



Overwrite?

If there is already a stitch or program saved in the machine memory and you press the save button this message will appear asking if you wish to overwrite the previously saved stitch/program with the new one. Select yes or no with the arrow buttons and press the OK button.

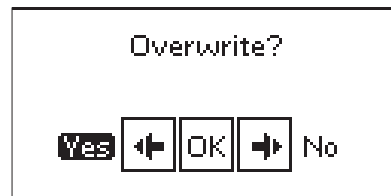

The Combination of Commands is Incorrect

If you are programming stitches or letters and try to insert a STOP or FIX command into a stitch program in an order that is not allowed, this message will appear. Close the pop-up message by pressing the OK button.

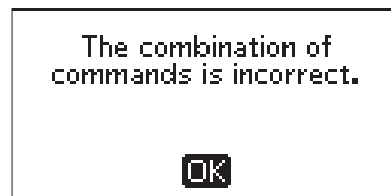

5 Sewing Techniques

Seam

A seam sews two pieces of fabric together with a seam allowance that will usually be pressed open. In most cases, edges of the seam allowance are finished with an overcast stitch before sewing the seam. Seams in stretch fabric must stretch with the fabric. The stretch stitch makes a stretchy seam that is suitable for sewing together pieces of light stretch fabric.

Fabric: Woven medium, cut in two.

Select: Woven medium fabric and seam technique. (The Exclusive SEWING ADVISOR™ feature selects a straight stitch.)

Use: Presser foot A and size 80 needle as recommended.

Set: Presser foot pressure to N as recommended.

Sew:

- Place fabric pieces right sides together. Put the fabric in position under the presser foot. Line up the edge with the $\frac{5}{8}$ " (15 mm) seam guide.
- Lower the presser foot.
- Sew a seam. When finished, press the cut function button. The machine cuts top and bobbin threads.
- Raise the presser foot and remove your project.

Tip: Straight stitch can also be used for topstitching. For a more visible topstitch, lengthen the stitch and use heavier thread with a larger size needle.

Fabric: Stretch light, cut in two.

Select: Stretch light fabric and seam technique. (The Exclusive SEWING ADVISOR™ feature selects a stretch stitch.)

Use: Presser foot A and size 75 stretch needle as recommended.

Set: Presser foot pressure to 2 as recommended.

Sew:

- Place fabric pieces right sides together. Put the fabric in position under the presser foot. Line up the edge with the $\frac{3}{8}$ " (10 mm) seam guide for a $\frac{5}{8}$ " seam.
- Lower the presser foot.
- Sew a seam. When finished, press the cut function button. The machine cuts top and bobbin threads.
- Raise the presser foot and remove your project.

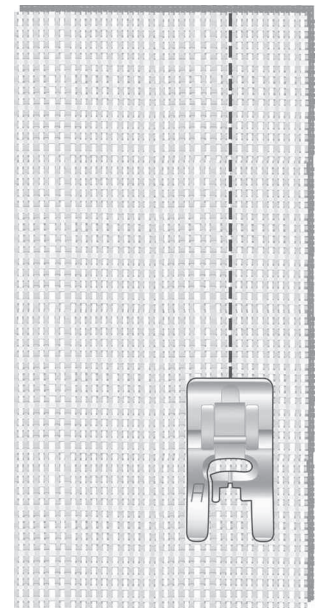
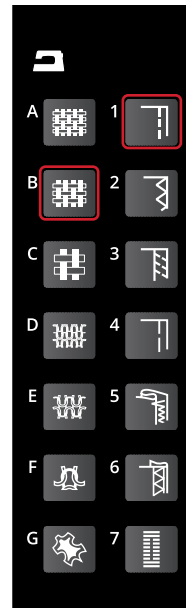

Straight stitch

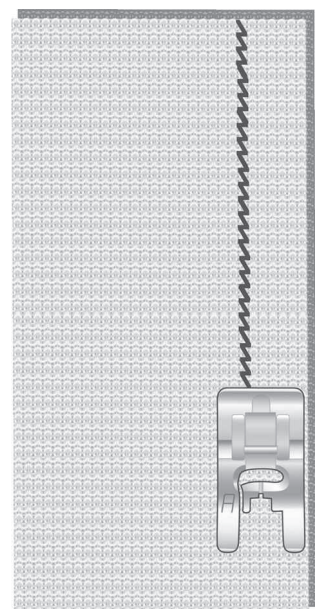
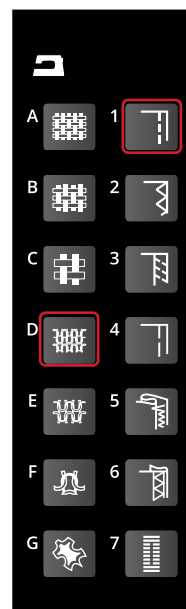

Stretch stitch

Overcast

Overcast fabric edges to prevent fraying and to help them lay flat. It is easier to overcast before the garment is sewn together. Presser foot J is recommended for light and medium weight fabric to prevent puckering along the edge. Presser foot B is used for heavy weight fabric. Your Exclusive SEWING ADVISOR™ feature will select the best stitch length and stitch width for the fabric weight and recommend the presser foot and needle.

Fabric: Woven medium.

Select: Woven medium fabric and overcast technique. (The Exclusive SEWING ADVISOR™ feature selects a three—step zigzag stitch.)

Use: Presser foot J and size 80 needle as recommended.

Set: Presser foot pressure to N as recommended.

Place the edge of a single thickness of fabric under presser foot J with the wire guide along the edge of the fabric. The three-step zigzag stitch sews over the wire guide to keep the edge of the fabric flat.

Sew:

- Lower the presser foot.
- Sew to overcast the edge of the fabric.
- When finished, press the cut function button. The machine cuts top and bobbin threads.
- Raise the presser foot and remove your project.

Note: It is not necessary to overcast leather or vinyl because they do not fray. However, the Exclusive SEWING ADVISOR™ feature allows you to, if desired. Select leather/vinyl fabric and overcast technique. (The Exclusive SEWING ADVISOR™ feature selects a zigzag stitch).

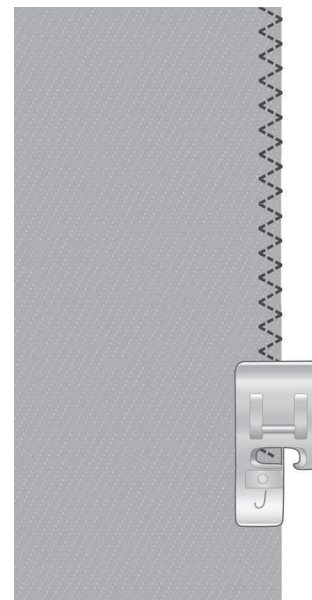

Seam and Overcast

The seam/overcast stitch sews the seam and overcasts the edges all at one time. There are a number of different seam/overcast stitches on your machine. Your Exclusive SEWING ADVISOR™ feature will select the best one for your fabric and make all adjustments automatically.

Fabric: Stretch light, cut in two.

Select: Stretch light fabric and seam/overcast technique on the Exclusive SEWING ADVISOR™ feature.

Use: Presser foot J and size 75 stretch needle as recommended.

Set: Presser foot pressure to 2 as recommended.

Sew:

- Place fabric pieces right sides together. Put the fabric in position under the presser foot with the wire guide on the foot along the edge of the fabric.
- Lower the presser foot.
- Seam/overcast along the edge. When finished, press the cut function button. The machine cuts top and bobbin threads.
- Raise the presser foot and remove your project.

Repeat the Seam/Overcast technique on stretch heavy fabric and on woven heavy fabric. Your Exclusive SEWING ADVISOR™ feature will select the best stitch, stitch length, stitch width and thread tension for each fabric type. Follow other recommendations given on the graphic display.

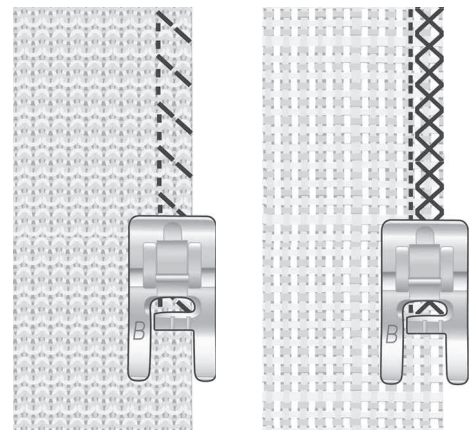
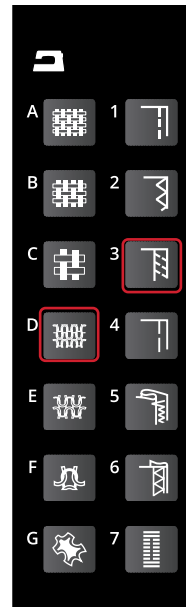

Left: Stretch heavy and seam/overcast. Right: Woven heavy and seam/overcast.

Baste

Basting is temporary stitching for fitting garments, gathering and marking.

The Exclusive SEWING ADVISOR™ feature automatically sets a long stitch length and reduces the tension so the threads are easy to remove or to pull for gathering.

Fabric: All types of fabric.

Select: The fabric you are using and baste technique. (The Exclusive SEWING ADVISOR™ feature selects the baste stitch.)

Use: Presser foot A, B or H (optional accessory, part number 4127961-45) and needle as recommended for your fabric.

Set: Presser foot pressure as recommended for your fabric.

Sew:

- Place fabric pieces right sides together. Put the fabric in position under the presser foot with $\frac{5}{8}$ " (15 mm) seam allowance.

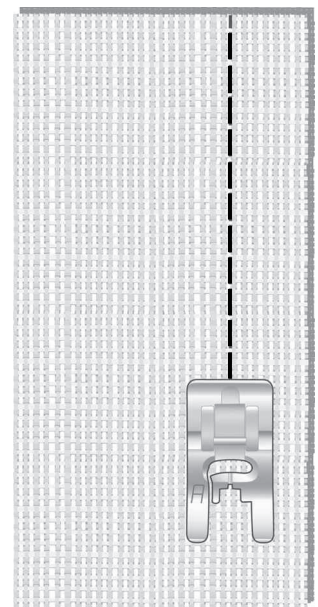
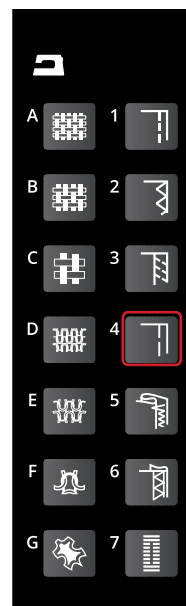

- Lower the presser foot.
- Sew along the seam line.
- Raise the presser foot and remove your project.
- To remove stitching, pull the bobbin thread.

Blind Hem

The blind hem creates an invisible hem on garments. There are two types of blind hem; one is recommended for medium to heavy woven fabrics, the other for stretch.

Fabric: Stretch medium/heavy or woven medium/heavy.

Select: The fabric you are using and blind hem technique.

Use: Blind Hem Foot D and the needle recommended for your fabric.

Set: Presser foot pressure as recommended for your fabric.

Sew:

- Fold the fabric as illustrated. Make sure the folded edge of the fabric follows the inside of the right “toe” of Blind Hem Foot D.
- Lower the presser foot.
- The left swing of the needle should just catch the edge of the folded fabric. If necessary, adjust the stitch width as needed to barely “catch” the fold.
- Sew the blind hem. When finished, press the cut function button. The machine cuts top and bobbin threads.
- Raise the presser foot and remove your project.

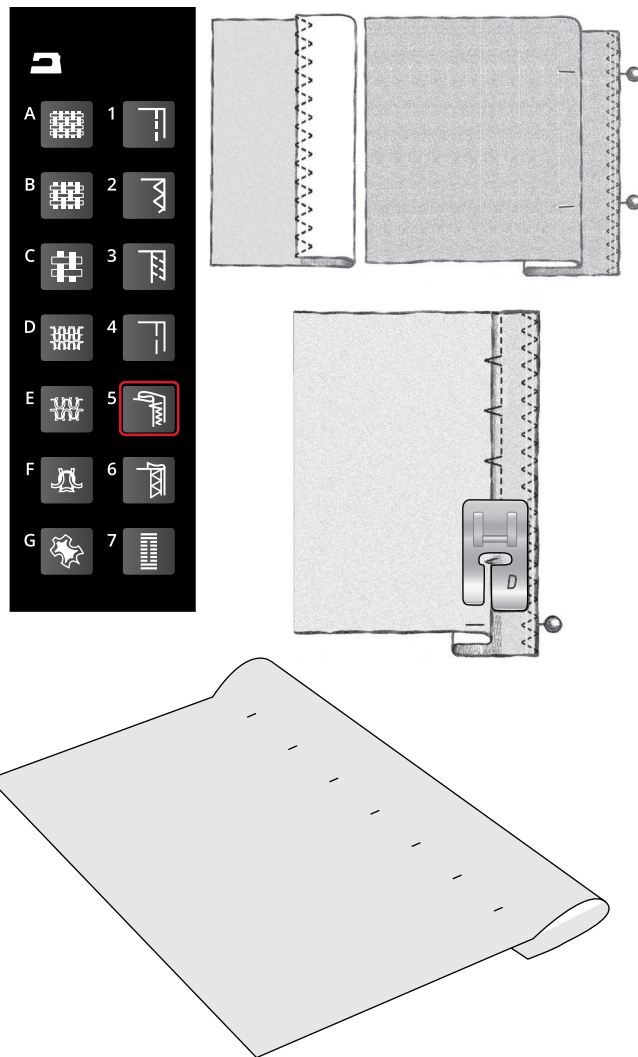

Hem

The hem technique on your Exclusive SEWING ADVISOR™ feature will select the visible or topstitch hem that is best for your fabric weight and type. For woven fabric and leather and vinyl, a straight stitch is selected. For stretch fabrics, stitches that stretch are selected.

Jeans Hem

When sewing over seams in extra heavy fabric or a blue jeans hem, the foot can tip as it rides over the seam. Use the optional multipurpose tool (part number 4131056-01) to balance the height of the presser foot as you sew.

Fabric: Denim fabric.

Select: Woven heavy and hem technique.

Use: Presser foot B as recommended and size 90 needle.

Set: Presser foot pressure to N as recommended.

Sew:

Press needle stop up/down to select the needle down position. Begin sewing the bottom hem at or near the center back. As you near the side seam, stop sewing. Your machine stops with the needle in the fabric. Raise the presser foot. Insert the multipurpose tool from behind.

Both sides of the multipurpose tool are raised. Use the side which corresponds closest to the thickness of the seam. Lower the presser foot and continue sewing slowly over the thick seam.

Stop sewing again just in front of the seam (notice how the needle is in the fabric). Remove the multipurpose tool and reinsert it under the presser foot from the front.

Sew a few stitches until the whole presser foot has passed the seam and is resting on the multipurpose tool. Stop sewing once again. With the needle in the fabric, raise the presser foot. Remove the multipurpose tool. Continue sewing the hem.

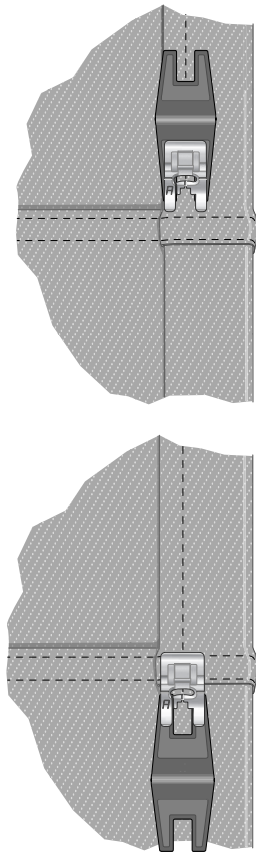
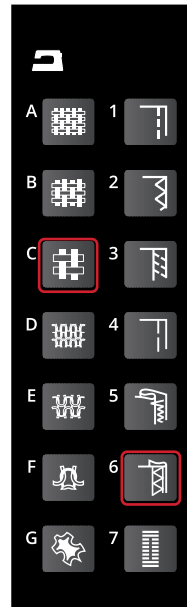

Stretch Hem

Select stretch medium and the Exclusive SEWING ADVISOR™ feature selects a flatlock stitch. Follow other recommendations given on the graphic display.

Fold a hem to the wrong side and stitch with flatlock stitch from the right side. Trim away excess fabric. Use this technique for belt loops too.

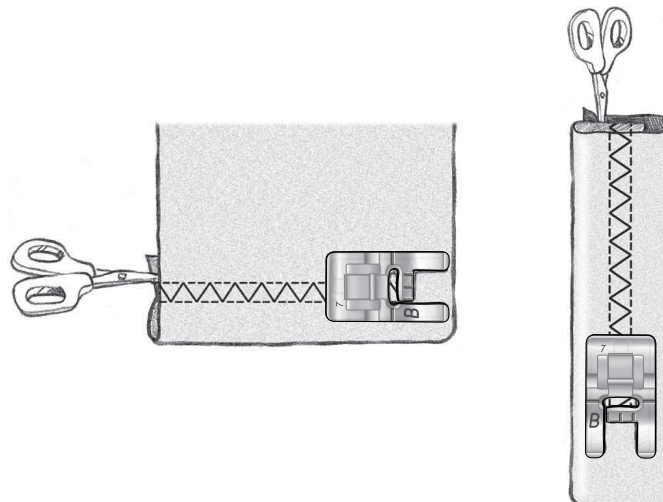

Flatlock stitch to hem stretch fabric and for belt loops.

Sewing Buttonholes

The buttonholes in your sewing machine are specially adjusted for different types of fabric and garments. Learn about different buttonholes and when to use them by studying the stitch table in the overview chapter.

The Exclusive SEWING ADVISOR™ feature will select the best buttonhole and stitch settings for your fabric. Fabric should be interfaced and/or stabilized where buttonholes are sewn.

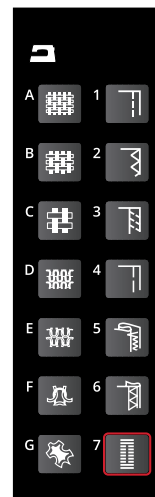

One-Step Buttonhole

Note: Always sew a test buttonhole on a scrap piece of fabric.

1. Mark the position of the buttonhole on your project.
2. Attach One-Step Buttonhole Foot C and pull out the button holder plate (A). Insert the button. The button will determine the length of the buttonhole.
3. Make sure that the thread is pulled through the hole in the presser foot and placed under the foot.
4. Position your project under the presser foot so that the marking on the fabric is aligned with the center of the buttonhole foot.
5. Lower the buttonhole lever (B) all the way down.

Note: The machine will not start to sew if the buttonhole lever is not lowered properly or the frame of buttonhole foot is not positioned all the way forward.

6. Hold the end of the upper thread and start sewing. The buttonholes are sewn from the front of the presser foot to the back.
7. Once the machine has sewn the buttonhole, raise the presser foot.

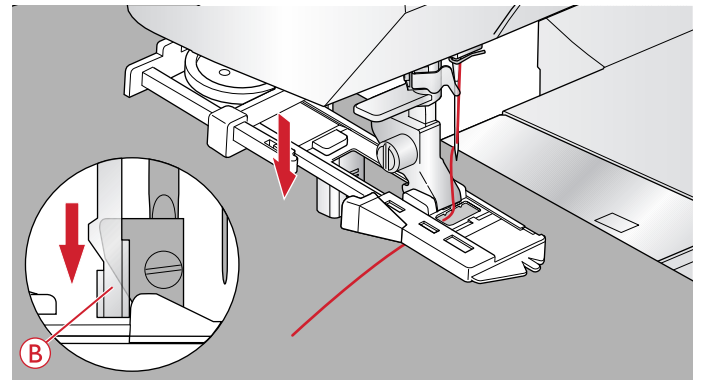
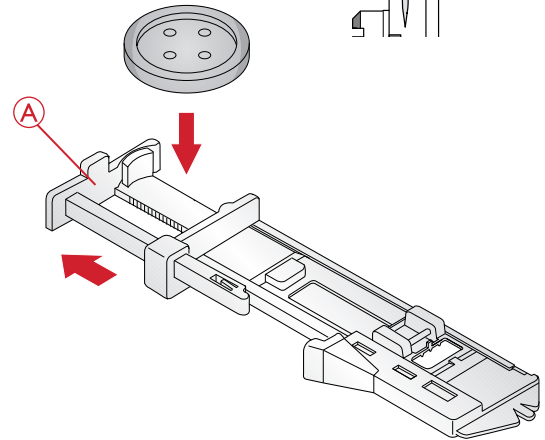
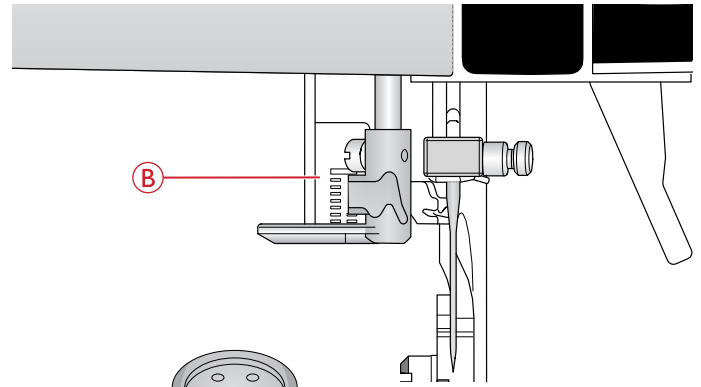

Manual Buttonhole

To sew a buttonhole longer than 25mm, use the manual buttonhole foot C.

1. Lower the buttonhole lever and presser foot. Press the start/stop button or the foot control to start sewing while pushing the buttonhole lever away from you until the machine starts sewing a straight stitch backwards. Sew until you reach the desired length of the buttonhole.
2. Pull the buttonhole lever towards you until the machine starts sewing the first column forwards.
3. When the column stitching has reached your desired length, push the buttonhole lever away from you until the machine starts sewing a straight stitch backwards.
4. Pull the buttonhole lever towards you until the machine starts sewing the bar tack and second column forwards.
5. When the columns are aligned, push the buttonhole lever away from you until the machine starts sewing the bar tack. The machine will sew a few tie-off stitches and stop automatically. The machine cuts the top and bobbin thread and raises the needle.

Depending on the style of buttonhole selected, the sewing sequence will differ, see illustration.

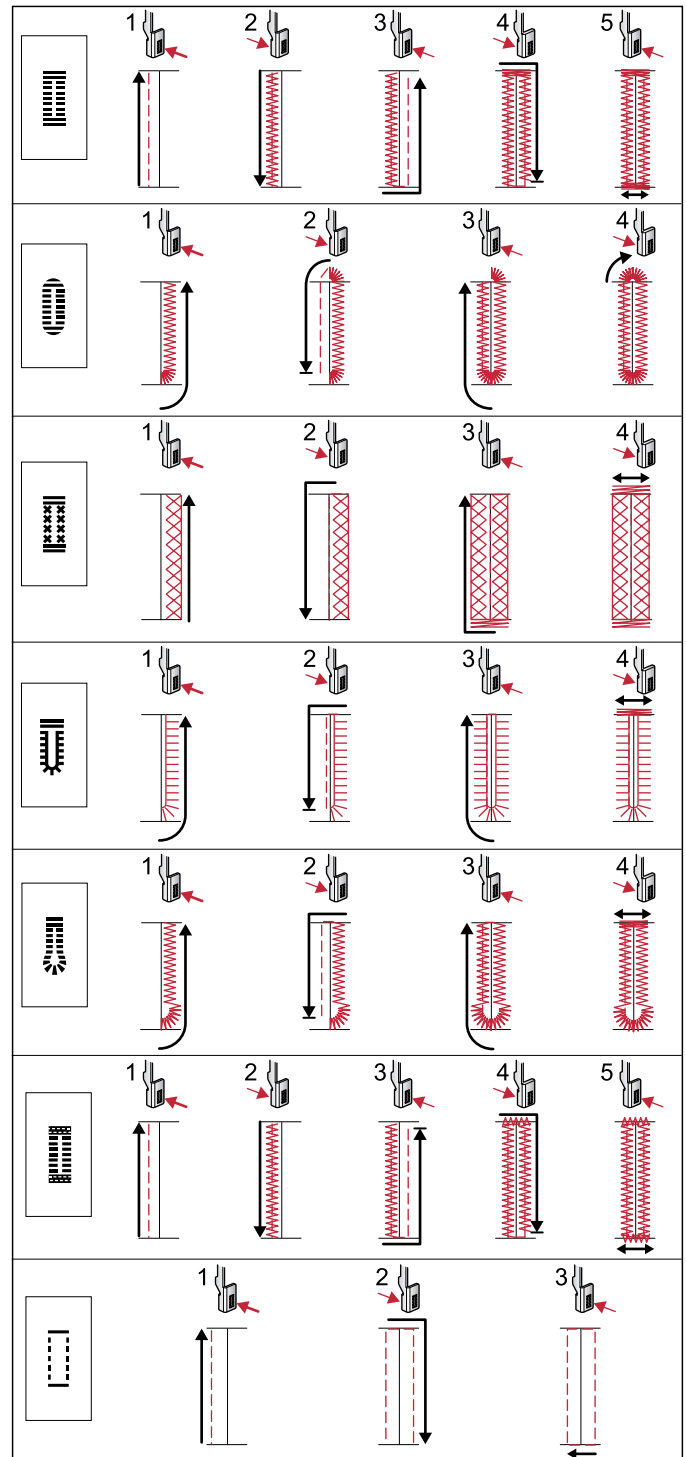

Sewing sequences for buttonhole stitches 0 and 1:24–1:29.

Corded Buttonhole (Stretch Fabrics)

When sewing buttonholes in stretch fabrics we recommend cording the buttonhole to increase the stability and keep the buttonhole from stretching out.

1. Loop a piece of heavy thread or pearl cotton over the metal bar extending from the center back of the manual buttonhole foot or of the plastic bar of the One-Step Buttonhole Foot. Pull the thread tails under the foot, towards the front, then secure around the finger at the front of the foot.
2. Stitch a buttonhole. The satin buttonhole columns will stitch over the cord.
3. When the buttonhole is finished, lift the cord off the finger and pull out the slack.
4. Cross the cord in front of the needle and thread cord ends into a large needle, pull to the wrong side and knot ends before cutting excess.
5. Use the seam ripper to carefully open the buttonhole.

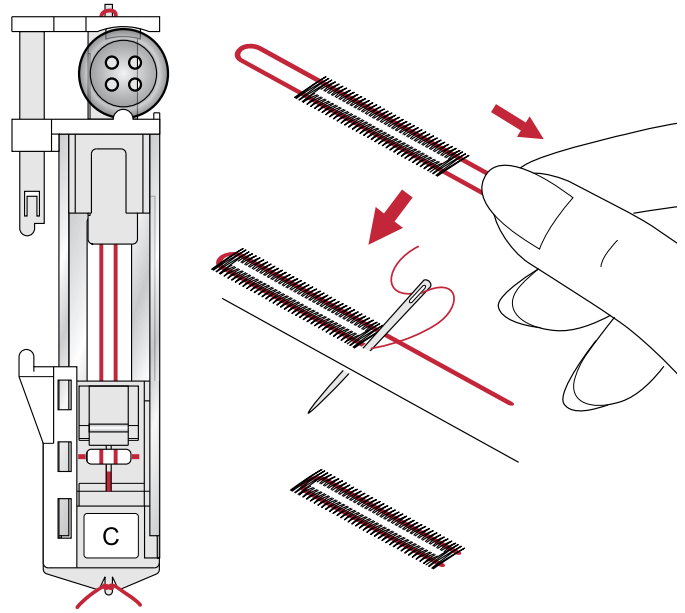

Sewing on Buttons

Sew buttons and snaps quickly with your sewing machine.

Select the fabric you are using and the stitch for sewing on buttons 1:09.

1. Snap off the presser foot and lower the feed teeth.
2. Place the fabric, multipurpose tool (optional accessory, part number 4131056-01) and button under the ankle with the holes in the button lined up with the swing of the needle. Check the swing of the needle by pressing the mirror side to side button to be sure the needle will not hit the button. Bring the needle down into the holes of the button with the handwheel to verify.

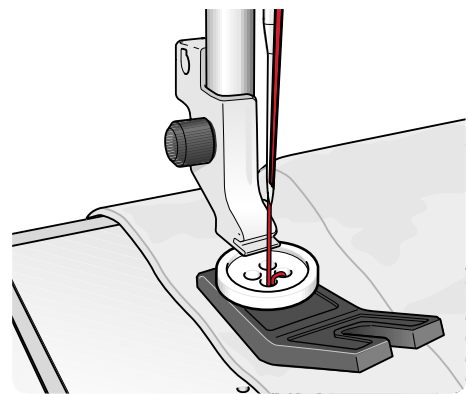

Tip: When using the multipurpose tool, the button is stitched to the fabric leaving a shank. If stitching without the multipurpose tool the button is stitched to the fabric without distance.

Tip: You can also use a sew-on button foot (part number 412934545), available as an optional accessory at your local authorized HUSQVARNA VIKING® retailer.

Note: The recommended width of 3.0 is set for most buttons. If you sew a tiny button or a very large coat button, decrease (-) or increase (+) the stitch width until the swing of the needle sews in the holes of the button.

3. Set the number of stitches to sew on the button (A) by pressing the up and down arrow buttons. Six to eight stitches is standard.
4. Press the foot control. The sewing machine will sew the number of stitches set on the display and then tie off and stop.
5. Raise feed teeth when button sewing is completed.

Tip: Place the thin end of the multipurpose tool under the button when sewing on light fabrics. Use the thick end for heavier fabrics. Hold in place on the fabric with transparent tape.

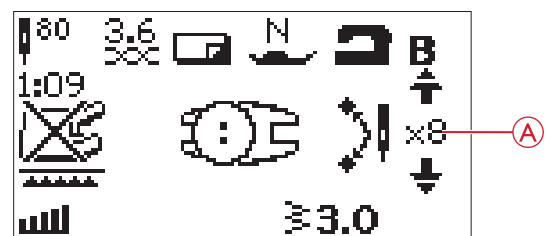

Sewing Zippers

The Zipper Foot E can be snapped on either the right or the left of the needle, making it easy to sew both sides of the zipper. To sew the other side of the zipper, reposition the Zipper Foot.

Move the needle position to the far left or right to stitch close to the zipper teeth or cording.

Center Zipper

1. Sew the two fabrics right sides together along the $\frac{5}{8}$ " (15 mm) seam line, stopping at the notch for the zipper placement.
2. Baste the remaining seam where the zipper will be placed. Press the seam open. Place the zipper right side to the pressed open seam allowance, placing the zipper stop at the notch. Pin the zipper on the right side so it stays in place (A).
3. Select straight stitch and move the needle position to the left. Snap on the Zipper Foot E so the needle is on the left side of the foot. Place fabric under the foot right side up with the zipper foot on the right side of the zipper.
4. Begin stitching across the bottom, turn the fabric and stitch the right side of the zipper to the top (B).
5. To avoid fabric shifting, sew the left side of the zipper in the same direction. Snap on the Zipper Foot E so the needle is on the right side of the foot. Move the needle position to the right.
6. Begin stitching across the bottom, turn the fabric and stitch the left side of the zipper sewing from the bottom to the top (C).
7. Remove the basting stitches.

Note: To adjust the position of the stitching line, adjust the needle position with the +/- buttons.

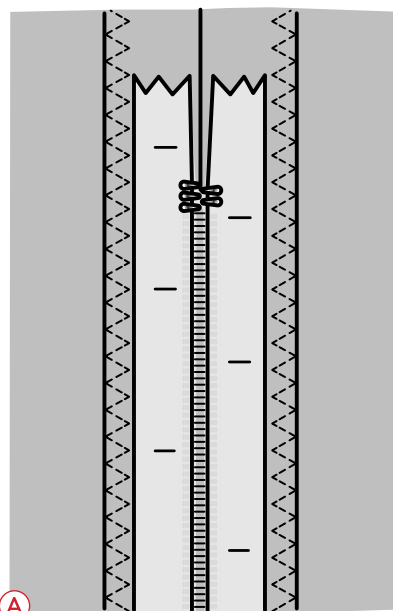
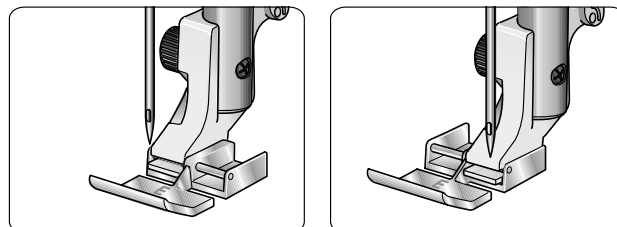

(A)

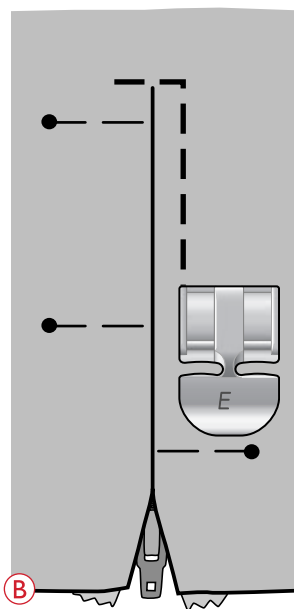

(B)

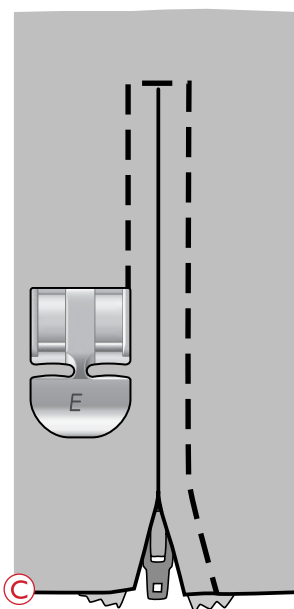

(C)

Darning and Mending

Darning a small hole or a tear before it becomes larger can save a garment. Choose a fine thread in a color as close to your garment as possible.

1. Place the fabric in position under the presser foot.
2. Start sewing above the hole and over it.
3. Once over the hole, press the reverse button. Continue sewing. The machine sews back and forth across the hole 16 times and then stops.
4. The LED next to the STOP button is lit automatically, indicating that the darning stitch can be repeated with the same size. Reposition your fabric, then step on the foot control to sew again. The stitch will now repeat the same size darning square. The machine will stop automatically when the stitch is completed. To cancel the repeat function, press the STOP button.

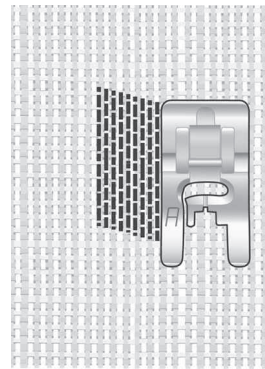

Select fabric type and stitch 1:21

Bartack (Manual)

Secure elastic ends, drapery pleats, belt loops, and pocket corners with the same look as ready-to-wear.

- Place fabric under the presser foot.
 - Lower the presser foot.
 - Step on the foot control.
1. Your machine will sew a straight stitch until you press reverse.
 2. Your machine will then sew in reverse until you press reverse again.
 3. Your machine will then sew a zigzag, covering the straight stitches.
 4. Press reverse to automatically tie off.

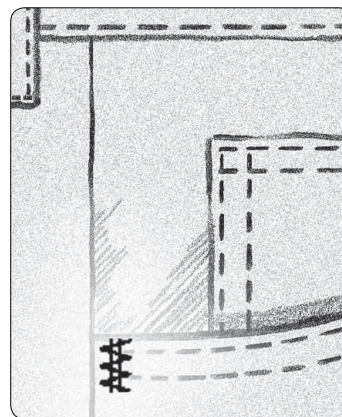

Woven heavy and stitch 1:22.

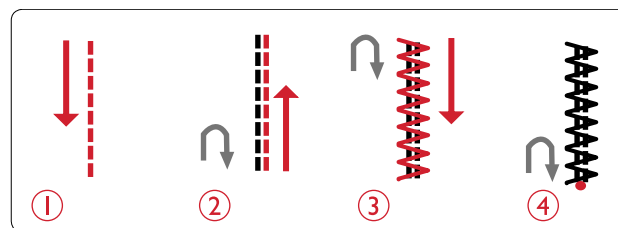

Quilting

A quilt usually consists of three layers, two layers of fabric with a layer of batting sandwiched between. To sew three layers together, you have a wide variety of stitches and techniques to choose from. When the quilting is finished simply bind the edges or make it into cushions, wearable art or other smaller projects.

Crazy Quilt Stitching

Embellish your quilt with decorative stitches. The stitches can be sewn in a coordinating or contrasting color. Decorative threads like rayon embroidery or heavy cotton threads are sometimes used. Find stitches perfect for crazy quilting on stitch menu 2.

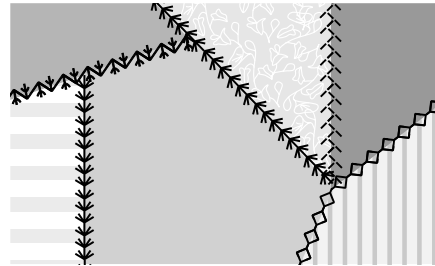

Hand-Look Quilting

Simulate the look of handmade quilting with invisible thread and the hand-look quilting stitch (2:11). This stitch is pre-set with a high thread tension to get the accurate hand stitched look. Thread the needle with clear invisible thread and the bobbin with a color of thread that coordinates with your fabric.

Stitch along one of the seams of your project. The hand-look effect is created as the bobbin thread is pulled up to the top of the quilt.

Note: When sewing with the hand-look quilting stitch, the result depends on what fabric, batting and thread you are using. Be sure to try the stitch on a sample first. Adjust the thread tension as needed for your project.

Note: Use the edge guide to sew successive rows. Insert the edge guide into the hole of the presser foot holder. Set the desired spacing by sliding the edge guide.

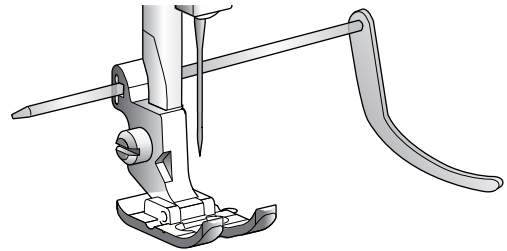

Free Motion Quilting

Free motion quilting not only keeps the top, batting and backing together, but it also adds texture and interest to your quilt.

There are several techniques to use when free motion quilting. Decorate your quilt as you like, only your imagination sets the limits. Two free motion techniques are stippling and circles.

Free motion stippling is typically a tightly and evenly spaced meandering stitch line. When stippling, draw squiggles with the needle as you sew. Another technique is to make circular motions on the fabric as you sew creating a stone shaped pattern.

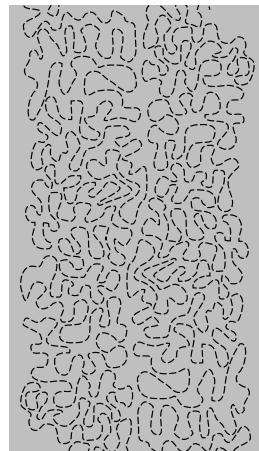

Free motion stippling.

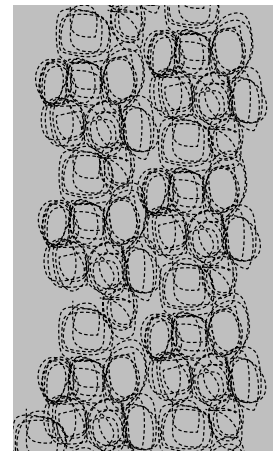

Free motion with circular motions.

Free motion quilting is done with the feed teeth lowered. You move the fabric manually to determine the stitch length. When free motion quilting, use the Open Toe Free Motion Spring Foot (optional accessory, part number 4130376-46) or the included Embroidery/Darning Foot U.

Begin by basting your quilt through all layers, starting from the center of your quilt and working out.

Note: When free motion sewing with more than 4mm stitch width, replace the short needle clamp screw with the long needle clamp screw found in the included accessories.

1. Attach the Open Toe Free Motion Spring Foot and lower the feed teeth. Select needle stop up/down to put the needle in down position.
2. Sew at a constant medium speed, moving the fabric at a consistent speed, this will help to keep the stitches even. The length of the stitch is created as you move the fabric.

Tip: Practice free motion sewing on scraps of the fabric and batting from your quilt. It is important to move your hands at the same speed as the needle to prevent stitches that are too long or too short. Maintaining a consistent speed while free-motion sewing will keep stitches even.

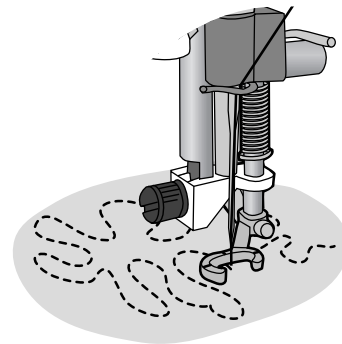

Open Toe Free Motion Spring Foot (optional accessory, part number 4130376-46).

6 Embroidery Preparations

Embroidery Unit

(type EU-3V)

1. Embroidery unit plug
2. Embroidery arm
3. Embroidery unit release button (underside)
4. Level adjusting feet
5. Embroidery hoop attachment

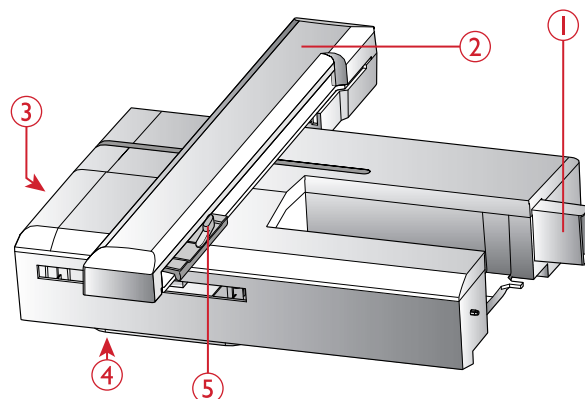

Embroidery Hoop Overview

1. Embroidery hoop connector
2. Outer hoop
3. Inner hoop
4. Quick release
5. Retaining screw
6. Center marks

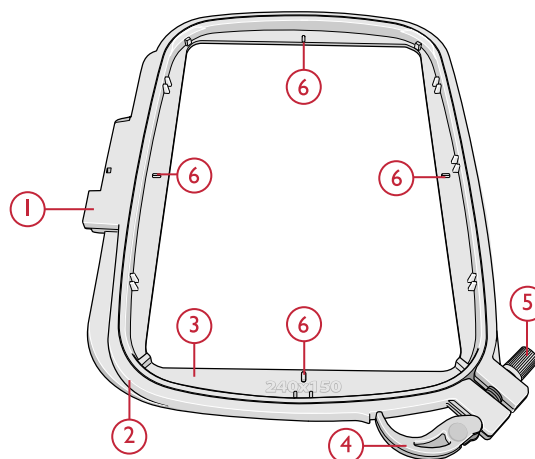

Designs

70 designs and 1 embroidery font are stored on the USB embroidery stick delivered with your machine. We recommend copying the font and designs to your computer as an easily accessible backup if you should lose the USB embroidery stick or if you temporarily want to remove the designs from the stick.

DESIGNER JADE™ 35 Sampler Book

Page through the DESIGNER JADE™ 35 sampler book found as a PDF-file on the USB embroidery stick, for an overview of the available designs and embroidery fonts.

The design number, stitch count (number of stitches in the design) and the design size are displayed next to each design. The suggested thread color for each color block is shown.

Download Backup Designs

All DESIGNER JADE™ 35 designs and other files are also available on our website for backup. Go to HUSQVARNA VIKING® website at www.husqvarnaviking.com, click on Support and select DESIGNER JADE™ 35. When downloading the files you will be asked to enter a code. Enter number:

9200jade35

Connect the Embroidery Unit

1. Make sure the machine is turned off.
2. Slide the accessory tray off.
3. Slide the embroidery unit onto the free arm of the machine until it plugs firmly into the socket at the back of the machine. If needed, use the level adjusting feet so that the machine and embroidery unit are even. If the machine is turned off, turn it on.
4. A pop-up message tells you to clear the embroidery area and remove the hoop for calibration. Press OK. The machine will calibrate and the embroidery arm will move to the ready position.

Note: DO NOT calibrate the machine with the embroidery hoop attached as this can damage the needle, presser foot, hoop and/or the embroidery unit. Be sure to clear all materials from around the machine before calibrating so that the embroidery arm does not bump into anything while calibrating.

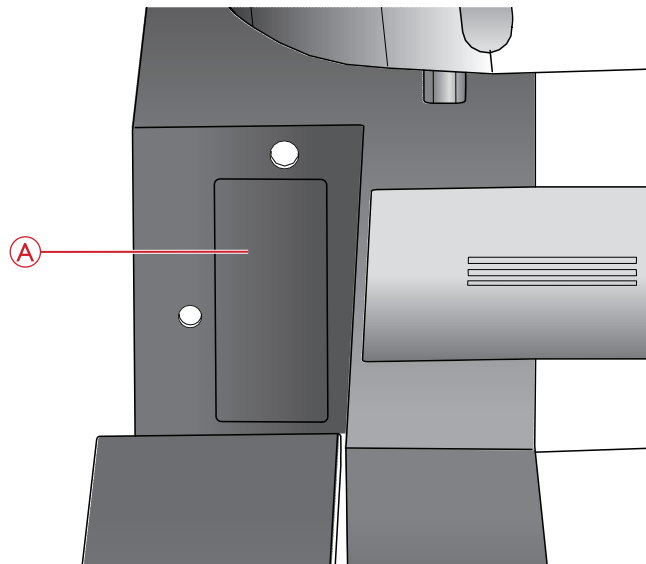

Embroidery unit socket (A)

Remove the Embroidery Unit

1. To store the embroidery unit, remove the hoop and move the embroidery arm to park position by pressing the needle stop up/down button. You can also select park position in the hoop options menu. Press the hoop options button to enter the menu. See [Park Position/Trim Position](#), page 70.

Note: It is very important that the hoop is removed, otherwise the hoop, needle or presser foot may be damaged.

2. Make sure the machine is turned off.
3. Press the button at the left, underneath the embroidery unit (A) and slide the unit to the left to remove it.

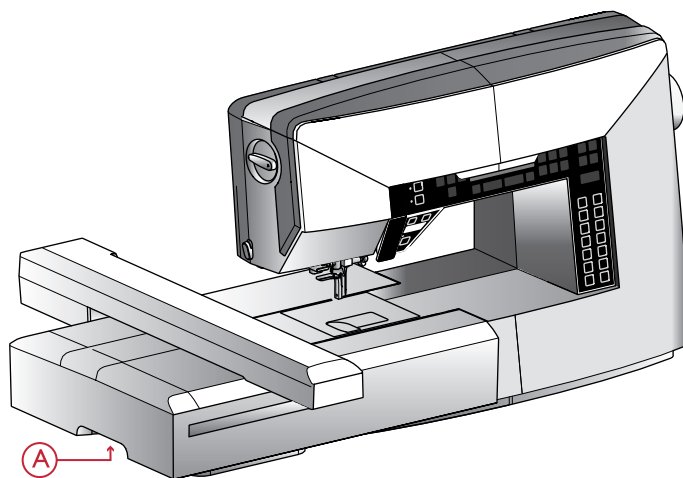

Attaching the Embroidery/Darning Foot U

1. Turn off the power switch to prevent accidents.
2. Turn the hand wheel toward you until the needle is at its highest point.
3. Raise the presser foot.
4. Remove the presser foot and holder by removing the presser foot screw (A).
5. Change the needle to an embroidery needle (B).
6. Attach the Embroidery/Darning Foot U to the presser bar (C) so that the arm (D) of foot rides on the shaft (E) of the needle clamp.
7. Attach the presser foot screw (A) and tighten it. For easier access, lower the needle slightly.

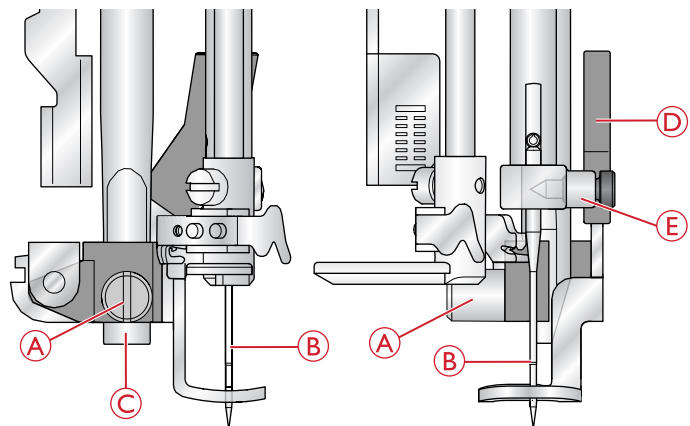

To Hoop the Fabric

For the best embroidery results, place a layer of stabilizer beneath the fabric. When hooping stabilizer and fabric make sure that they are smooth and securely hooped.

1. Open the quick release (A) on the outer hoop and loosen the screw (B). Remove the inner hoop. Place the outer hoop on a firm flat surface with the screw on the lower right (B). There is a small arrow in the center of the lower edge of the hoop which will line up with a small arrow on the inner hoop.
2. Place the stabilizer and fabric, with the right sides facing up, on top of the outer hoop. Place the inner hoop on top of the fabric with the small arrow at the bottom edge. If you can see the hoop size in the lower part of the inner hoop, you have attached it correctly.
3. Push the inner hoop firmly into the outer hoop.
4. Close the quick release (A). Adjust the pressure of the outer hoop by turning the retaining screw (B). The fabric should be taut in the hoop for the best results.

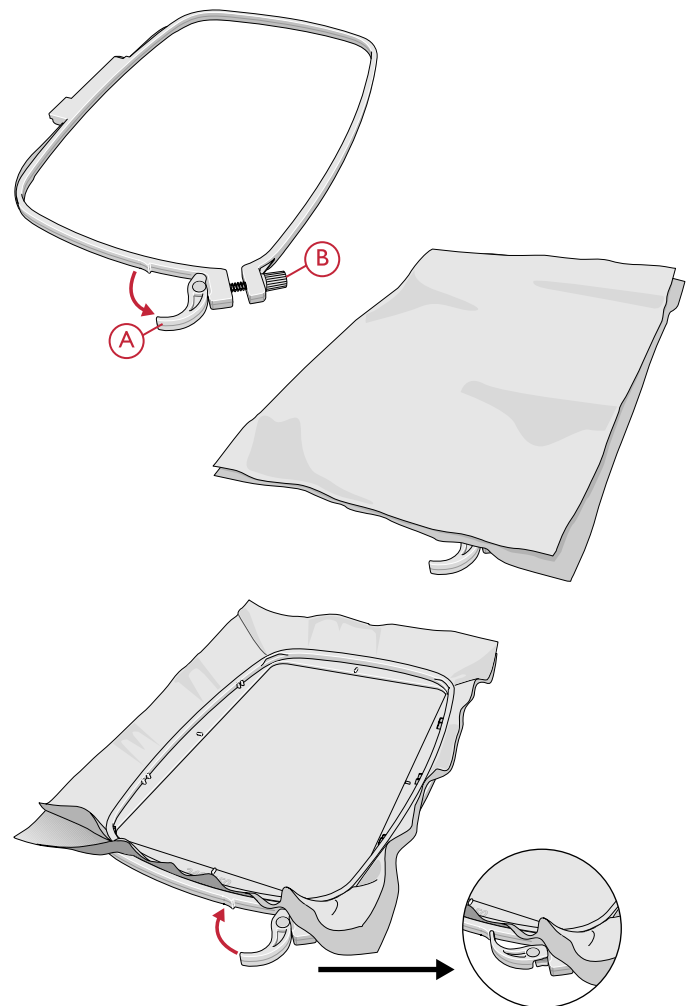

Note: When embroidering additional designs on the same fabric, open the quick release, move the hoop to the new position on the fabric and close the quick release. When changing type of fabric, you might need to adjust the pressure using the retaining screw. Do not force the quick release.

Slide on/off the Hoop

Slide the hoop connector into the hoop attachment (A) from front to back until it clicks into place.

To remove the hoop from the embroidery arm, press the grey button (B) on the hoop attachment and slide the hoop towards you.

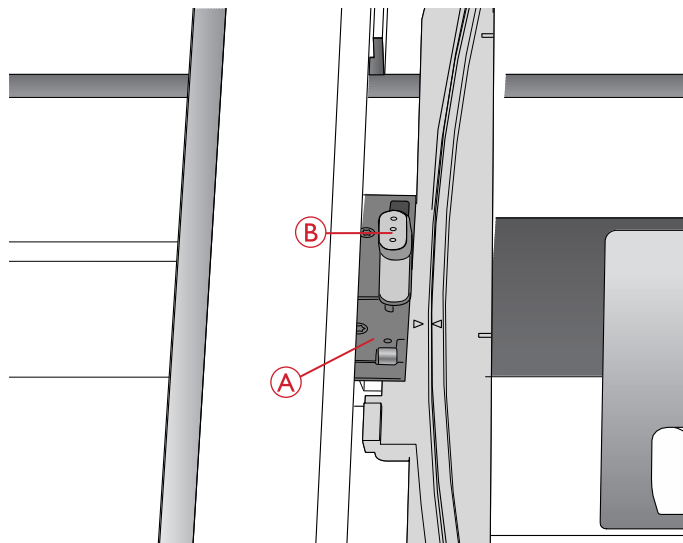

Getting Started Embroidering

1. Make sure the machine is turned off and Attach the embroidery unit. The machine starts in embroidery mode. A pop-up message prompts you to clear the embroidery area for calibration. Press OK to calibrate and move the embroidery arm to ready position.
2. The load menu automatically opens. Make sure that the USB embroidery stick is connected. Select your design using the arrow buttons and confirm with OK. The design is placed in the center of the hoop.
3. Attach the embroidery foot and insert a bobbin with lightweight bobbin thread.
4. Hoop a piece of fabric and stabilizer and slide the hoop onto the embroidery arm.
5. Your machine automatically selects the smallest hoop size that fits the design. Make sure that the hoop attached matches the hoop size shown on the graphic display or change hoop size by pressing the hoop options button and select correct size from the list (see [Hoop Size, page 69](#)).
6. Thread the machine with the first color in the color block list. To show the complete color block list on the graphic display press the embroidery info button.
7. Clear sufficient space to accommodate movement of the embroidery arm and the hoop. Hold the needle thread and press the start/stop button. The machine will start embroidering.

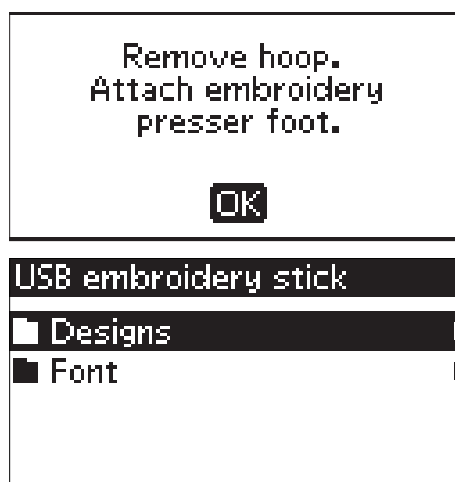

8. After stitching a few stitches, the machine stops and a pop-up message appears on the graphic display asking you to cut the thread end. Cut the thread and press the start/ stop button to continue embroidering.



Note: Automatic stop for cut is activated by default. Open the SET menu to deactivate this setting. Automatic stop for cut is disabled if you use the foot control when embroidering.

9. When the first color is completed, your machine stops. A pop-up message appears on the graphic display asking you to change color. Re-thread with the next color and continue embroidering by pressing the start/ stop button. Each color segment is tied off at the end and the needle and bobbin threads are cut.



Note: When you start embroidering again, hold the thread end so you can easily remove it when cut.

10. When the embroidery is completed your machine stops automatically. The needle and bobbin thread are cut. Raise the presser foot for easy removal of the hoop. A pop-up message informs you that your embroidery is finished. Close the pop-up message by pressing the OK button.



7 Embroidery Mode

In embroidery mode you can adjust the position and size of your designs and stitch them out. The machine automatically switches to embroidery mode when the embroidery unit is attached. Functions used when embroidering are now shown.

Embroidery Mode Overview

In embroidery mode there are two different views on the graphic display; embroidery edit view and embroidery stitch-out view. Use the alternate view button (A) to switch between the views.

Edit View

1. Embroidery area
2. Design placement and size
3. Embroidery speed indicated by five levels. Reduce or increase the speed by pressing speed – or speed + (see [Speed + and –, page 26](#)).
4. Design height. Reduce or increase the design height by pressing – or + (B) (see [Design Height, page 68](#)).
5. Design width. Reduce or increase the design width by pressing – or + (C) (see [Design Width, page 68](#)).
6. Current view (1: Edit, 2: Stitch-out)
7. Horizontal and vertical position of design. Shows in millimeters how much the design has been moved from its original position (0).
8. Design rotation. Indicates how many degrees a design has been rotated from its original position.
9. Indicates that the function mirror side to side is activated.
10. Indicates that the function mirror end to end is activated.

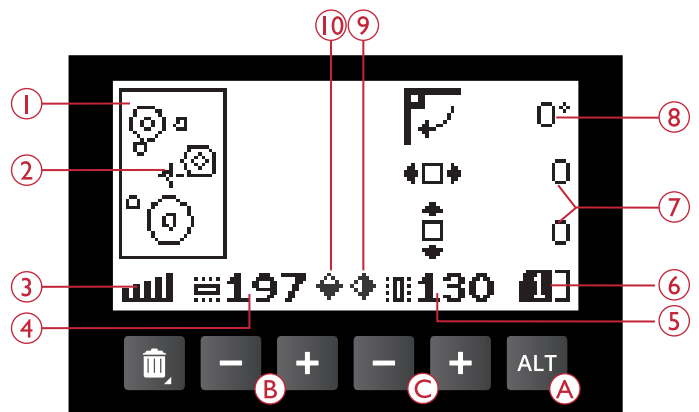

Embroidery mode, edit view

Stitch-Out View

1. Selected hoop. When a design is loaded to the embroidery area the smallest hoop that fits the design is automatically selected.
2. Remaining stitches in embroidery. Will count down as you embroider.
3. Current color block and total number of color blocks in embroidery.
4. Current stitch in the current color block and number of stitches in the current color block.

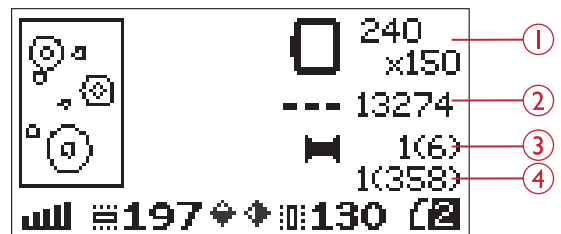

Embroidery mode, stitch-out view

Load a Design

To load a design press the stitch menu button (A) with the USB embroidery stick connected. Your machine can load .vp3 embroidery files and .vf3 embroidery font files.

Select a design from the files and folders shown in the menu. Use the arrow up/down buttons to select a folder and then press the OK button to open it. To go back to the previous folder, press the left arrow button or select the top line and press the OK button.

Select the design you want to load and press OK to confirm. It will be loaded into the embroidery area.

Note: If you have already loaded a design into the embroidery area, the next design you load will automatically replace the first one.

Note: When saving designs on the USB embroidery stick, make sure not to create too many levels of subfolders as this may create a file path that is too long. Also make sure to keep the file name short. When trying to open a file/folder that has too long of a name or too many subfolders, an alarm will sound and the file/folder will not open.

Tip: Convert your designs between different embroidery formats using the downloadable software. See [Complimentary Embroidery Intro Software \(PC\)](#), page 24.

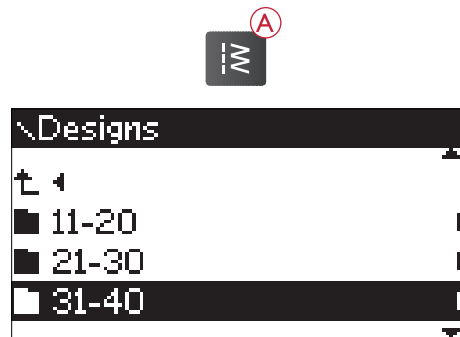

Load a Font

One font is stored on the USB embroidery stick upon delivery. To load a font press the stitch menu button (A) with the USB embroidery stick connected. Font files are marked with an icon (B) in the list. You can select between three different files with different sizes of the included font, 12 mm, 20 mm and 30 mm. Select the font file you want to load and press OK to confirm. A text editor opens.

Create additional embroidery fonts from fonts available on your PC computer with the HUSQVARNA VIKING® QuickFont software, which is available for download at www.husqvarnaviking.com (see [Complimentary Embroidery Intro Software \(PC\)](#), page 24).

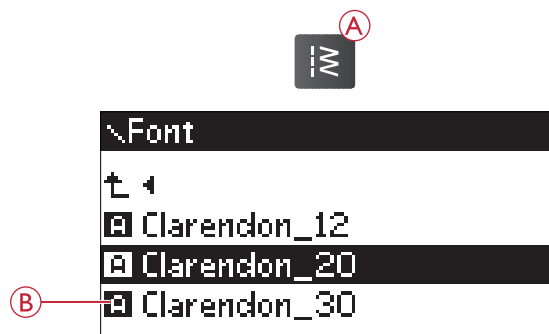

Add a Letter

When loading a font the upper case alphabet is shown in the text editor. Use the arrow buttons to select a letter and press OK to add the letter to the program. To switch to lower case alphabet or numbers press the shift button (C).

If you wish to add a letter at another position move the cursor in the program by pressing the left/right arrow buttons. The letter will be inserted to the right of the cursor.

Note: Press the arrow down button to activate the cursor in the program instead of in the alphabet.

The height and width of the program are also shown on the graphic display (D).

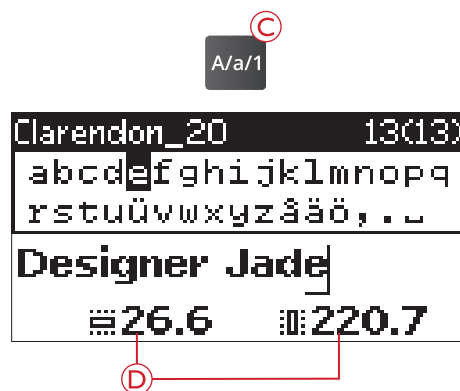

Delete a Letter

To delete a letter select the letter with the cursor by pressing the arrow buttons and press the delete button (A).

To delete the whole program, move the cursor to the left of the first position and press the delete button or press and hold on the delete button at any position in the program. A pop-up message will appear asking you to verify the deletion. Select yes or no with the arrow buttons and press OK.



Load Text to Embroidery

When you want to stitch out the text, press the program mode button (B) to load the text to embroidery mode. The text is now handled as one design and you can make adjustments on the entire text. If you wish to go back to the text editor and make further adjustments on the text before stitching it out press the program mode button again.

Note: All adjustments made in embroidery mode will be cancelled if you go back to the text editor.

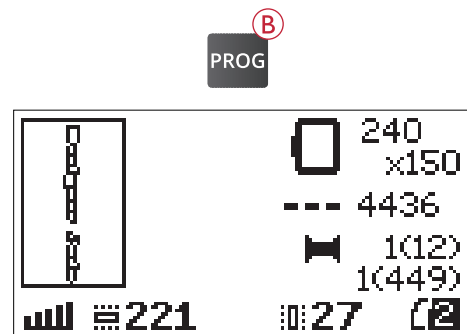

Embroidery Information

To view information about a design before loading it to embroidery mode, select the file in the load menu and press the embroidery info button (C).

If a design file is selected, an info view opens where you can see design size, number of stitches and number of color blocks in the design.

If a font file is selected, an info view opens where you can see font name, size and character set.

Press the left arrow button or info button to close the information view and go back to the load menu.

When you have loaded a design into embroidery mode, press the embroidery info button to view information about the current design.

1. Design name
2. Number of color blocks in the design
3. Number of stitches in the design
4. Color block list. All colors in the loaded design are shown in the order they will be embroidered. The current color block is always placed at the top of the list and is marked with a thread spool. Each listed color shows order, name, thread manufacturer and color code. Use the up/down buttons to scroll through the list.

Note: In the downloadable software you can find information about thread manufacturers and thread type abbreviations. See [Complimentary Embroidery Intro Software \(PC\)](#), page 24.

Press the embroidery info button once more to close the information view.

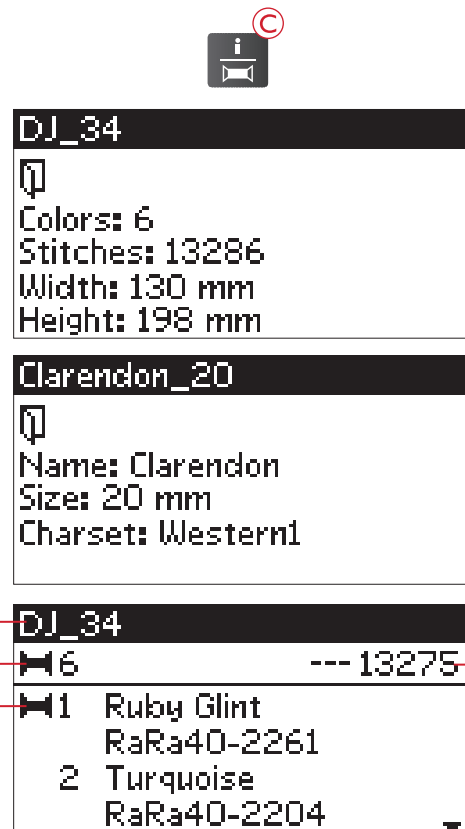

Adjust Designs

There are many options for adjusting your designs. Always make adjustments before starting to embroider. The settings are shown on the graphic display. If you change the numbers for width and height the figures will be inverted on a black background. The changes are also visible on the graphic display.

Design Height

You can increase or decrease the size of the design up to 20%. Increase or decrease the design height using the + and – buttons below the setting displayed on the graphic display. The design height is scaled 5% each time you press the button. The stitch count remains the same.

Design Width

You can increase or decrease the size of the design up to 20%. Increase or decrease the design width using the + and – buttons below the setting displayed on the graphic display. The design width is scaled 5% each time you press the button. The stitch count remains the same.

Note: You can resize the design in the Complimentary Embroidery Intro Software (PC).

Move Designs to Position

Place your design anywhere in the embroidery area using the arrow buttons (A). The numbers to the right of the design position icons on the graphic display show in millimeters how much the design has been moved vertically and horizontally from its original center position.

Rotate and Mirror Design

Rotate

You can rotate the design around its center point. Each time you press the rotate button (B), the design will rotate 90 degrees clockwise. To the right of the rotate icon on the graphic display you can see how many degrees the design has rotated from its original position.

Note: Some designs are too large to rotate 90 degrees. Each press of the button will then rotate the design 180 degrees.

Note: The rotate function is only available in embroidery edit view.

Mirror Side to Side

Press the mirror side to side button (C) to mirror the loaded design side to side. An icon is shown on the graphic display indicating that mirror side to side is selected.

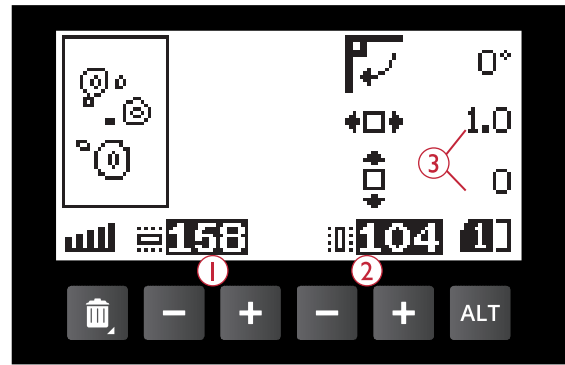

1. Design height
2. Design width
3. Move designs to position

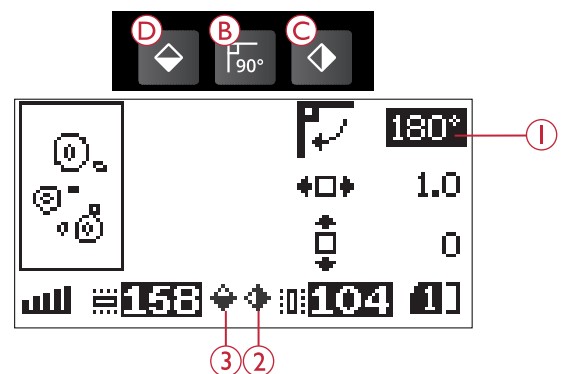
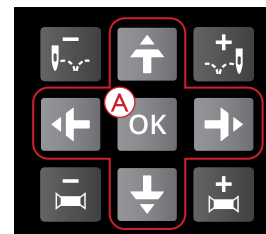

1. Rotate
2. Mirror side to side
3. Mirror end to end

Mirror End to End

Press the mirror end to end button (D) to mirror the loaded design end to end. An icon is shown on the graphic display indicating that mirror end to end is selected.

Hoop Options

Press the hoop options button (A) to open a list of hoop options. Use the up/down arrow buttons to make a selection and confirm by pressing the OK button. Close the hoop options menu by pressing the hoop options button again or select the current stitch position.

Hoop Size

When a design is loaded to the embroidery area the smallest hoop that fits the design is automatically selected.

Use the right arrow button to open a list of available hoop sizes, including hoops that are available to purchase from your authorized retailer. Depending on the size of the design, some hoops may not be available for selection.

Use the up and down arrow buttons to select a different hoop and confirm your selection by pressing the OK button.

Note: If you start embroidering and the hoop you have selected is not the same as the hoop attached to the embroidery unit, a pop-up message will appear to inform you. Attach the correct hoop or select another hoop in the list.

Current Stitch

If you have selected one of the hoop positions and want to return to the current stitch and start embroidering where the embroidery was interrupted, select current stitch. You can also press the start/stop button once to return to current stitch and start to embroider.

Park Position

When you have finished your embroidery, remove the hoop and select park position. The embroidery arm will be placed in the position for storing your embroidery unit.

Note: It is very important that the hoop is removed, otherwise the hoop, needle or presser foot may be damaged.

Trim Position

Trim position will move the hoop towards you, making it easier to trim fabric when embroidering an appliqué.

Center Position

Use the center position if you want to check where the center position of the hoop will be placed on the fabric.

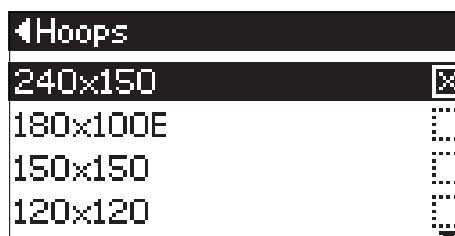

Embroidery Functions

One-Color Embroidery (Monochrome)

Press STOP (1) to cancel the color stops if you want to sew a design in one color only.

Basting

Press the FIX button (2) and the machine will add a basting stitch around the design area. Basting enables you to secure your fabric to the stabilizer placed beneath. It is especially useful when the fabric to be embroidered cannot be hooped. Basting provides support for stretchy fabric and also shows where the design will be placed on the fabric.

Park Position/Trim Position

Remove the hoop and press the needle stop up/down button (3) to put the embroidery unit in park position for easy storage.

Press the needle stop up/down button when the hoop is attached and the hoop moves towards you, making it easy to trim fabric when embroidering an appliqué. Cut the fabrics and press the button again. The hoop moves back to the current stitch. Press start/stop to resume the embroidery.

Note: The hoop options menu will open to show the actual position.

Corner Check

Corner check can be used to trace the four corners of the design. Press the corner check button (4). Each time you press the button the hoop will move to one of the corners in the following order: upper left, upper right, lower right and lower left. On the fifth press the hoop will move to the center position of the design and on the sixth press back to the current stitch position. A crosshair will indicate the current needle position on the graphic display.

The corner check function also shows where the design will be embroidered on the fabric. This makes it easier to position designs when embroidering several designs in succession.

Step Stitch by Stitch

Use the step stitch by stitch – and + buttons (5) to step through the design stitch by stitch. If the top or bobbin thread runs out or is broken, step backwards a few stitches before starting to embroider again. Current stitch number is shown on the graphic display in the stitch-out view.

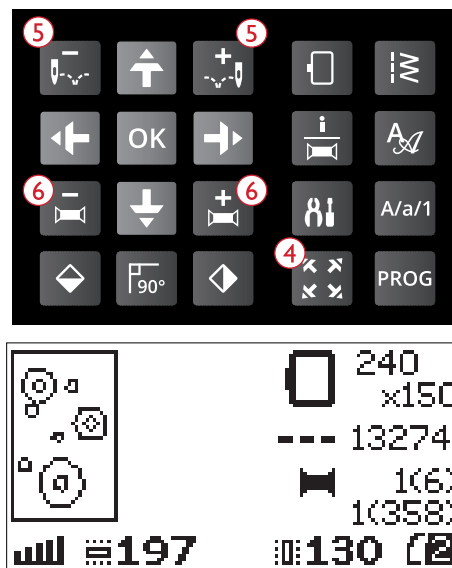
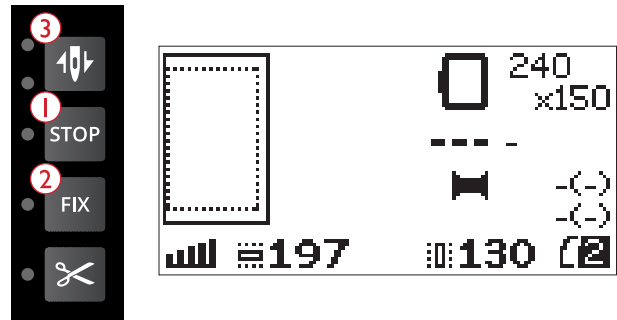

Step Color by Color

Use the step color by color – and + buttons (6) to step to the first stitch of the previous or next color. The current color block number is shown next to the total number of color blocks in the design, shown in parenthesis, in the Stitch-out view on the graphic display. Press the embroidery info button to view the complete color block list.

Embroidery Pop-Up Messages

Remove Hoop. Attach Embroidery Presser Foot

When the embroidery unit is attached, a pop-up message asks you to slide off the hoop and clear the machine area for calibrating the embroidery arm. You will also be reminded to attach the U foot for embroidery. Press the OK button to calibrate.

Note: It is very important to remove the hoop, otherwise the hoop or the embroidery unit may be damaged while calibrating.



Embroidery Unit Not Supported. Please Replace Embroidery Unit

You can only use the embroidery unit that is delivered with your machine. Attach the correct embroidery unit.

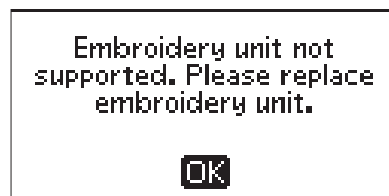

Calibration Failed

The machine was unable to calibrate. Clear the machine area for calibrating the embroidery arm and press the OK button.

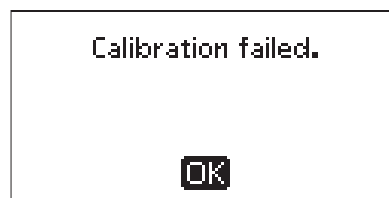

Please Raise the Presser Foot

Some functions are only possible with the presser foot raised. When trying to perform these functions with the presser foot lowered this pop-up message is shown. Raise the presser foot and press the OK button to close the pop-up message.



Please Lower the Presser Foot

Your machine will not embroider if the presser foot is raised. Lower the presser foot and press the OK button to close the pop-up message.



Attach Correct Hoop

When the size of the hoop on the machine does not match the size displayed on the graphic display, your machine will not sew. Change the hoop to the size displayed or change the setting for hoop size to match your selected hoop, see [Hoop Size, page 69](#).

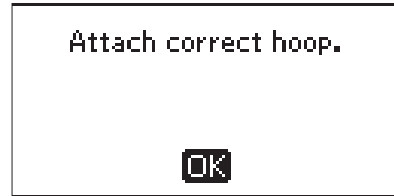

Check Upper Thread

Your machine stops automatically if the top thread runs out or breaks. Re-thread the top thread and close the pop-up message by pressing the OK button. Press the start/stop button to continue.

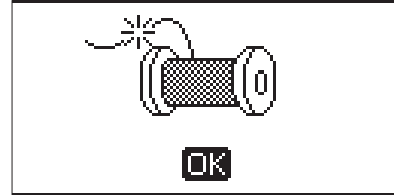

Cut Thread End

When starting to embroider or after changing the thread, the machine will sew a few stitches and then stop so you can cut the thread end.

Note: This function is cancelled if the automatic stop for cut function is deselected in the SET menu, see [Automatic Stop for Cut \(Only in Embroidery Mode\), page 30](#).



Change Thread Color

When it is time to change the needle thread the machine stops and the threads are cut. Change the spool and re-thread the machine. The next recommended color is shown in the popup message.

This popup message is also shown when your machine stops automatically for you to trim the fabric on cut work, applique etc. See explanation for each design in the DESIGNER JADE™ 35 sampler book.

Read about the sampler book on [page 59](#).



Design Includes Elements That Cannot Be Opened

Some designs may contain data that is too complex for this embroidery machine. Please use the downloadable software to re-save the design, see [Complimentary Embroidery Intro Software \(PC\), page 24](#).

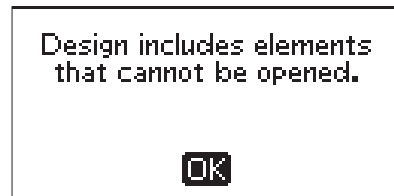

Remove the Hoop

This pop-up will appear when a function has been chosen that forces the embroidery unit to move outside the limits for the attached hoop. In order for the embroidery arm to move freely, remove the hoop and then press the OK button.

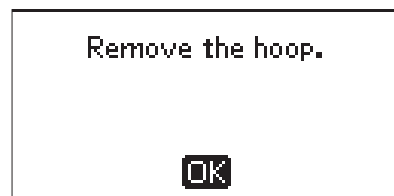

Connect USB Embroidery Stick

If you attach the embroidery unit or press the stitch menu button in embroidery mode without having a USB stick connected, this pop-up message will appear. Connect a USB stick and press the OK button so that you can load a design. This pop-up message also appears if the USB stick is removed while a design is being loaded or stitched out.

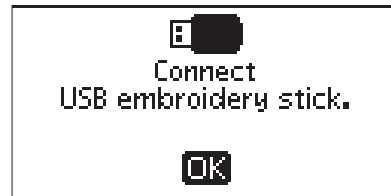

The Data on the USB Embroidery Stick is Not Readable

This pop-up message will appear when your sewing machine can not access the information on the USB embroidery stick. The USB stick could be damaged or you might be using a USB stick that is non-compatible with the sewing machine. Press the OK button to close the pop-up message.

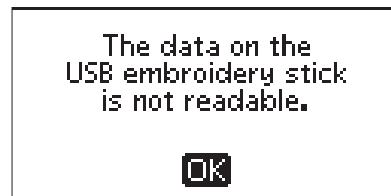

Embroidery Finished

A pop-up message informs you when the embroidery is finished. Press the OK button to close the pop-up message.

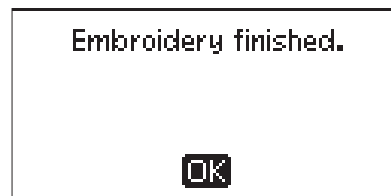

Embroidery Too Large

This pop-up message appears if the size of the design you are trying to load is too large or if the design contains too many stitches. Your machine can load designs containing up to 50,000 stitches. Press the OK button to close the pop-up and select another design.

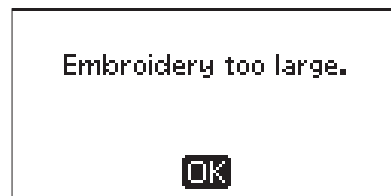

Stop Command in Design

Your machine stops automatically for you to trim the fabric on cut work, applique etc. See explanation for each design in the DESIGNER JADE™ 35 sampler book.

Read about the sampler book on [page 59](#).



This Will Restart and Clear All Adjustments, Return to Stitch Out?

This pop-up message will appear if you press the program mode button after starting the embroidery to go back to the text editor and change an existing embroidery text. If you select no the text editor will open and all your adjustments made in embroidery mode will be cancelled. If you select yes you will return to embroidery mode and all your adjustments will be kept. Use the arrow buttons to select yes or no and press the OK button.

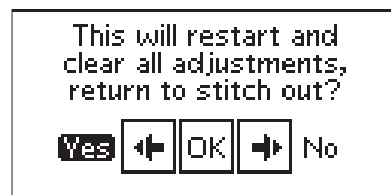

8 Maintenance

Cleaning the Machine

To keep your sewing machine operating well, clean it often. No lubrication (oiling) is needed. Wipe the exterior surface of your machine with a soft cloth to remove any dust or lint built up. Wipe the graphic display with a clean, soft and damp cloth.

Cleaning the Bobbin Area



Lower the feed teeth and turn off the machine.

Remove the presser foot. Push the bobbin cover release button (A) to the right and remove the bobbin cover (B) and the bobbin. Use the screwdriver for the needle plate to remove the two screws (C) in the needle plate. Lift up the needle plate. Clean the feed teeth and bobbin area with the brush included with the accessories.

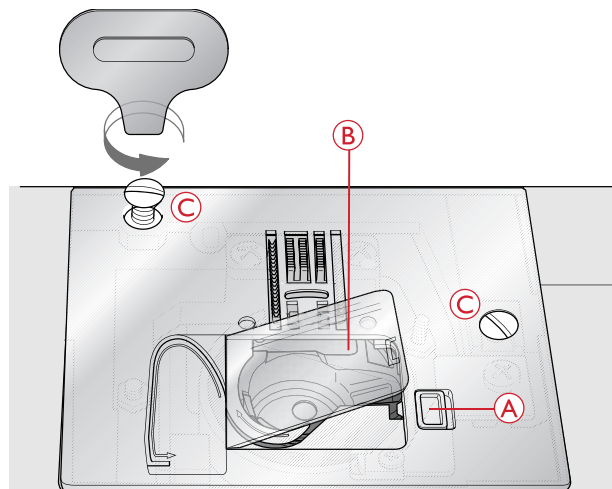

Cleaning Under the Bobbin Area

Clean the area under the bobbin case after sewing several projects or any time you notice an accumulation of lint in the bobbin case area. Remove the bobbin case by lifting it up. Clean the area with the brush or a dry cloth.



Use caution when cleaning around the thread cutter knife (B).

Put the bobbin case in place so that the tip (A) fits into the stopper (C).

Note: Do not blow air into the bobbin case area. The dust and lint will be blown into your machine.

Note: When using the optional accessory HUSQVARNA VIKING® Embroidery Cutwork Needles, it is necessary to clean the bobbin area after each embroidered design/project.

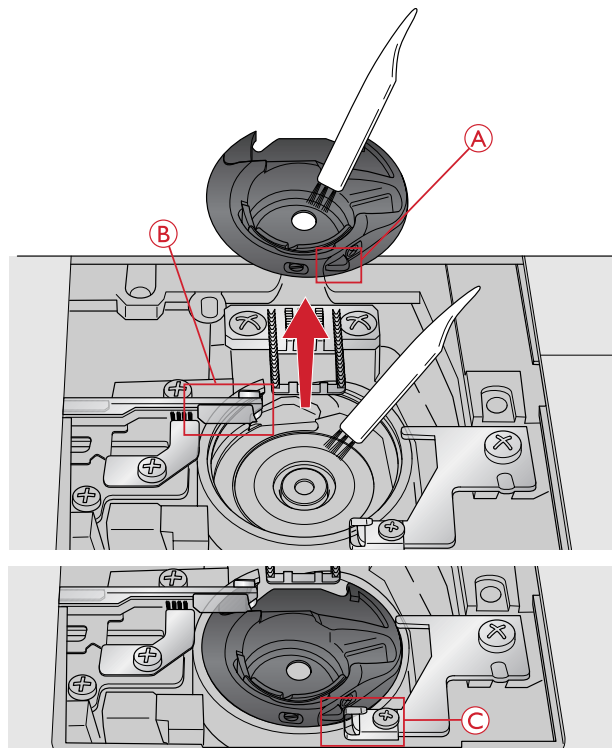

Replacing the Needle Plate

With the feed teeth lowered, replace the needle plate and insert and tighten the two needle plate screws.

Replace the bobbin cover.

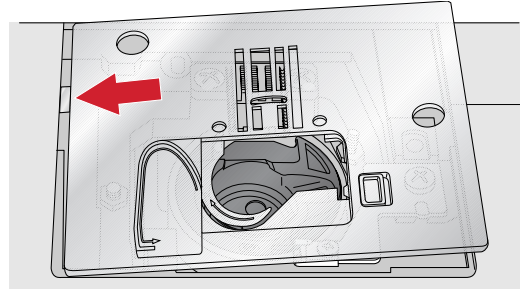

Troubleshooting

In this troubleshooting guide you will find solutions to any issues you may have with your machine. For further information please contact your local authorized HUSQVARNA VIKING® retailer who will be happy to help you.

General Problems

Thread cutter does not cut the thread?	Remove the needle plate and clean lint from bobbin area. Enable cut auto in the SET menu.
Fabric does not feed?	Make sure the feed teeth are not lowered.
Wrong stitch, irregular or narrow stitch?	Deactivate twin needle or stitch width safety in the settings menu.
The needle breaks?	Insert needle correctly as described, see page 23 . Use a needle suitable for selected fabric.
The machine will not sew?	Check that all plugs are securely plugged into the machine and the wall socket. Check that the foot control cord is securely plugged into the front socket on the bottom right side of the machine. Push bobbin winder spindle to sewing position.
The sewing and embroidery machine function buttons do not respond to touch?	The sockets and function buttons on the machine can be sensitive to static electricity. If the buttons do not respond to touch, turn the machine OFF and then ON again. If the problem persists, contact your local authorized HUSQVARNA VIKING® retailer.

The Machine Skips Stitches

Did you insert the needle properly?	Insert needle correctly as described, see page 23 .
Did you insert a wrong needle?	Use needle system 130/705 H. Use a needle suitable for selected fabric and thread.
Is the needle bent or blunt?	Insert a new needle.
Did you thread the machine properly?	Remove the thread completely and rethread the machine, see Threading the Machine, page 16 .
Is the correct presser foot used?	Attach correct presser foot.
Is the needle too small for the thread?	Change the needle.

Needle Thread Breaks

Did you insert the needle properly?	Insert needle correctly as described, see page 23 .
Did you insert a wrong needle?	Use needle system 130/705 H. Use a needle suitable for selected fabric and thread.
Is the needle bent or blunt?	Insert a new needle.
Did you thread the machine properly?	Remove the thread completely and rethread the machine, see Threading the Machine, page 16 .
Is the needle too small for the thread?	Change the needle to the proper size for the thread.
Are you using poor thread with slubs or thread which has become dry?	Change to a new high quality thread purchased from an authorized HUSQVARNA VIKING® retailer.
Is the correct spool cap used?	Attach the correct spool cap for your thread spool.
Is the best spool pin position used?	Try a different spool pin position (vertical or horizontal).
Is the needle plate hole damaged?	Change the needle plate.

Bobbin Thread Breaks

Did you insert the bobbin properly?	Check the bobbin thread.
Is the needle plate hole damaged?	Change the needle plate.
Is the bobbin area full of lint?	Clean lint from bobbin area and use only the bobbins approved for this model.
Is the bobbin wound correctly?	Wind a new bobbin.

The Seam Has Uneven Stitches

Is the thread tension correct?	Check needle thread tension. Remove the thread completely and rethread the machine, see Threading the Machine, page 16 .
Is the thread you are using thick or slubbed?	Change the thread.
Is the bobbin thread evenly wound?	Check bobbin winding.
Is a correct needle used?	Insert a proper needle correctly as described, see page 23 . Use a needle suitable for selected fabric and thread.

The Machine Does Not Feed or Feeds Irregularly

Did you thread the machine properly?	Remove the thread completely and rethread the machine, see Threading the Machine, page 16 .
Has lint collected between the feed teeth?	Remove the needle plate and clean the feed teeth with the brush.
Are the feed teeth lowered?	Raise the feed teeth.

Unable To Sew a Buttonhole

Are you experiencing problems when using the One-Step Buttonhole Foot?	Lower the buttonhole lever all the way down. Lower the presser foot gently.
--	---

The Embroidery Design is Distorted

Is the fabric hooped properly?	The fabric must be tightly hooped.
Is the inner embroidery hoop completely inserted in the outer embroidery hoop?	Hoop the fabric so that the inner hoop is inserted properly into the outer hoop.
Is the area around the embroidery arm and hoop free?	Clear area around the embroidery unit.
Is the hoop attached properly?	Make sure the hoop connector is inserted all the way into the hoop attachment on the embroidery arm.

The Embroidery Design has Puckered

Did you stabilize your fabric sufficiently?	Ensure you use the proper stabilizer for your technique or fabric type. Go to www.husqvarnaviking.com and locate the accessory user's guide for information about available stabilizers.
---	--

The Machine Will Not Embroider

Is the embroidery unit attached?	Make sure that the embroidery unit is properly attached into the socket.
Is the wrong hoop attached?	Slide on the correct hoop.

Have Your Sewing Machine Serviced Regularly by Your Local Authorized Retailer!

If you have followed this troubleshooting information and still have problems, contact your retailer. It may be helpful to bring the fabric, thread and stabilizer you are using with you. If you have a stitch out that shows the problem, please bring that as well. A sewing sample will often give better information than words and help your technician diagnose the problem.

Non-Original Parts and Accessories

The warranty does not cover any defect or damage caused by use of non-original accessories or parts.

Technical specification

Sewing machine

Rated voltage	100–240V ~ 50/60Hz
Nominal consumption	55W
Light	LED
Sewing speed	800 rpm maximum
Machine dimensions:	
Length (mm)	464
Width (mm)	193
Height (mm)	316
Net weight (kg)	9.0

Foot Control

Model	C-9002
Rated voltage	DC 15V, max. 3mA

- The technical specifications and this owner's manual can be changed without prior notice.

Index

- A**
- About Programming Letters 41
 - Accessories 8
 - Accessory Tray 7
 - Add a Letter 65
 - Add Commands 42
 - Add Letters 41
 - Add Stitches or Letters at Other Positions 42
 - Add the Same Stitch Several Times 42
 - Adjust a Single Stitch or Letter 43
 - Adjust Designs 68
 - Adjust the Entire Stitch Program 43
 - Alphabets 12
 - Alternate View (ALT) 27
 - Attaching the Embroidery/Darning Foot U 61
 - Audible Alarm 30
 - Automatic Stop for Cut 30
 - Auxiliary spool pin 8
 - Auxiliary Spool Pin 15
- B**
- Bartack (Manual) 56
 - Baste 48
 - Basting 70
 - Blind Hem 49
 - Blind Hem Foot D 9
 - Bobbin cover 6
 - Bobbin spindle, bobbin stop 6
 - Bobbin Thread Breaks 76
 - Bobbin winder thread guide and tension disc 6
 - Bobbin Winding 18
 - Bobbins 8
 - Brush 8
 - Buttonhole Foot C 9
 - Buttonhole lever 7
 - buttonholes 51
- C**
- Center Position 69
 - Center Zipper 55
 - Changing the Needle 23
 - Changing the Presser Foot 20
 - Cleaning the Bobbin Area 74
 - Cleaning the Machine 74
 - Cleaning Under the Bobbin Area 74
 - Complimentary Embroidery Intro Software (PC) 24
 - Connect the Embroidery Unit 60
 - Connect the foot control cord 13
 - Connect the power cord 13
 - Connect to and Remove From USB Port 23
 - Contrast 30
 - Corded Buttonhole (Stretch Fabrics) 54
 - Corner Check 70
 - Crazy Quilt Stitching 57
 - Create a Stitch Program 41
 - Current Stitch 69
 - CUT Auto (Only in Sewing Mode) 29
 - Cut Function 26
 - Cutting the Thread 17
- D**
- Darning and Mending 56
 - Decorative Stitch Foot B 9
 - Decorative stitches 11
 - Delete 26
 - Delete a Letter 66
 - Delete Stitches or Letters 42
 - Design Height 68
 - Design Width 68
 - Designs 59
 - Download Backup Designs 60
 - Drop feed teeth switch 7
- E**
- edge guide 57
 - Edge guide 8
 - Edging Foot J 9
 - Edit View 64
 - Elongation 38
 - Embroidery arm 8
 - embroidery font 59
 - Embroidery Functions 70
 - Embroidery hoop attachment 8
 - Embroidery Hoop Overview 59
 - Embroidery Information 67
 - Embroidery Mode Overview 64
 - Embroidery Pop-Up Messages 71
 - Embroidery Unit 8, 59
 - Embroidery unit connection socket 7
 - Embroidery unit plug 8
 - Embroidery unit release button 8
 - Embroidery/Darning Foot U 9
 - Exclusive SEWING ADVISOR™ 35
- F**
- Fabric Selection 35
 - feed teeth 20
 - felt pad 15
 - Felt pad 8

FIX Auto.....	29
FIX Function (Baste).....	26
Free arm.....	6
Free Arm.....	14
Free Motion Quilting.....	58
Front	6
Function Buttons	25
Function panel and graphic display.....	6

G

General Problems	75
Getting Started Embroidering	62

H

Hand-Look Quilting.....	57
Handle	7
Handwheel.....	6
Hem	50
Hole for auxiliary spool pin.....	6
Hoop Options.....	69
Hoop Size.....	69
Hoop the Fabric	61
How to Update Your Machine.....	24

I

Important Needle Information.....	22
Inserting the Bobbin.....	19

J

Jeans Hem	50
Join Two Stitch Programs Into One.....	42

L

Language	31
Leather.....	36
LED lights.....	6
LED Lights.....	14
Level adjustment feet.....	8
Lid with stitch overview	6
Load a Design	65
Load a Font	65
Load a Saved Stitch or Program.....	44
Load Text to Embroidery	66
Long needle clamp screw.....	8
Lowering the Feed Teeth	20

M

Machine Memory.....	43
Machine Overview	6
Manual Buttonhole.....	53
Mirror End to End.....	38, 69
Mirror Side to Side	38, 68
Monochrome	70
Mounting Machine in Sewing Cabinet.....	14
Move Designs to Position.....	68

N

Navigator Arrows and OK	27
Needle Area	7
Needle bar	7
Needle clamp screw.....	7
Needle plate.....	6
Needle Position	38
Needle Stop Up/Down.....	25
Needle Thread Breaks.....	76
Needle thread guide.....	7
Needle threader	7
Needle Threader	16
Needles	22

O

ON/OFF switch.....	6, 13
One-Color Embroidery.....	70
One-Step Buttonhole.....	52
One-Step Buttonhole Foot	9
Overcast.....	47

P

Pack Away After Sewing.....	14
Park Position.....	69–70
Presser bar	7
Presser Feet.....	9
Presser foot.....	7
Presser foot ankle.....	7
Presser foot lift.....	7
Presser Foot Lift	20
Presser Foot Pressure.....	20
Presser foot pressure dial.....	6
Program Pop-Up Messages.....	45

Q

Quilt stitches	11
Quilting.....	57

R

Rear Side	7
Remove the Embroidery Unit	60
Replacing the Needle Plate.....	75
Reverse	26
Rotate	68

S

Sampler Book.....	59
Satin and heirloom stitches	11
Save a Stitch or a Program	44
save button	44
Screwdriver	8
Screwdriver for needle plate	8
Seam.....	46
Seam and Overcast.....	48
Seam ripper.....	8
Selecting a Font	34
Selecting a Stitch	34
Self-Adhesive Glide Plate	9
SET Menu	29
Sew out the Stitch Program.....	43
Sewing Buttonholes.....	51
Sewing Mode Overview	32
Sewing on Buttons	54
Sewing Techniques	36
Sewing Zippers.....	55
Slide on/off the Hoop	62
sockets for power cord and foot control.....	6
Software Version.....	31
Speed + and -	26
spool cap	15
Spool cap, large.....	8
Spool cap, small	8
Spool pin.....	6
Spool Pins	15
Stabilizers	21
Start/Stop.....	26
Step Color by Color.....	71
Step Stitch by Stitch.....	70
Stitch Density.....	37
Stitch Length.....	37
Stitch Menus	11
Stitch Overview	10
Stitch Selection Buttons.....	26
Stitch Settings.....	37
Stitch Width.....	37
Stitch Width Safety.....	30
Stitch-Out View.....	64
STOP Function (Monochrome).....	25
Storage Box	7
Stretch (knit) fabric.....	35
Stretch Hem.....	51

T

Technical specification	78
The Embroidery Design has Puckered	77
The Embroidery Design is Distorted.....	77
The Machine Does Not Feed or Feeds Irregularly.....	76
The Machine Skips Stitches.....	75
The Machine Will Not Embroider.....	77
The Seam Has Uneven Stitches	76
Thread cutter.....	6
Thread cutter for bobbin thread	6
Thread guide	6
Thread guide for auxiliary spool.....	6
Thread guide for bobbin winding through the needle	6
thread net	15
Thread net	8
Thread Sensor	20
Thread take-up lever.....	6
Thread Tension	19, 29
Thread tension discs	6
Threading for Twin Needle.....	17
Threading the Machine	16
Threads.....	21
Trim Position	69–70
Troubleshooting	75
twin needle	17
Twin Needle.....	30

U

Unable To Sew a Buttonhole.....	76
Unpacking	13
Updating Instructions	24
USB embroidery stick	8, 59
USB Embroidery Stick.....	23
USB port	6
USB Port.....	23
Utility Foot A	9
Utility Stitches	10

V

Vinyl.....	36
------------	----

W

Winding From Horizontal Position	18
Winding Through the Needle.....	19
Woven fabric.....	35

Z

Zipper Foot E	9
---------------------	---

You have purchased a modern, updatable sewing and embroidery machine. As we regularly release software updates, it is possible that there may be some differences between the machine software and the software described in the User's Guide. Consult your local Authorized HUSQVARNA VIKING® retailer, and be sure to visit our website at www.husqvarnaviking.com for the latest updates of the software and the User's Guide.

We reserve the right to change the machine equipment and the assortment of accessories without prior notice, or make modifications to the performance or design. Such modifications, however, will always be to the benefit of the user and the product.

INTELLECTUAL PROPERTY

DESIGNER, DESIGNER JADE, SEWING ADVISOR, VIKING and KEEPING THE WORLD SEWING & Design are trademarks of KSIN Luxembourg II, S.ar.l. HUSQVARNA and the "crowned H-mark" are trademarks of Husqvarna AB. All trademarks are used under license by VSM Group AB.



Please note that on disposal, this product must be safely recycled in accordance with relevant National legislation relating to electrical/electronic products. Do not dispose of electrical appliances as unsorted municipal waste, use separate collection facilities. Contact your local government for information regarding the collection systems available. When replacing old appliances with new ones, the retailer may be legally obligated to take back your old appliance for disposal free of charge.

If electrical appliances are disposed of in landfills or dumps, hazardous substances can leak into the groundwater and get into the food chain, damaging your health and well-being.

CE – Authorised Representative

VSM GROUP AB, **SVP Worldwide**

Drottninggatan 2, SE-56184, Huskvarna, SWEDEN

