

NON-SLIP MACHINE
QUILTING TOOL



Dot

By Angela Walters

1/4" THICK HIGH-GRADE ACRYLIC

Designed by machine quilting teacher and author, Angela Walters, Dot is like getting two rulers in one, making it an all-around functional tool to have around. Quilt along the outside to create straight lines in different angles, or quilt along the inside to create beautiful curvy, pointy shapes. To learn more, view a video demonstration.

Features:

- Creative Grids® grip to ensure the ruler doesn't slip while quilting
- Black and white dashed guide lines that are visible on all fabric colors
- Needle stops for quick repositioning

Use it for:

- Geometric shapes
- Dot-to-dot quilting
- Stitching in the Ditch
- Echo lines
- Triangles
- Wedges
- Border designs
- Motifs
- Overlapped diamonds and more...



SEE A DEMO
SCAN WITH ANY
QR READER

**Remove glue dots from
back of tool before using.**

CREATE THESE DESIGNS & MORE...

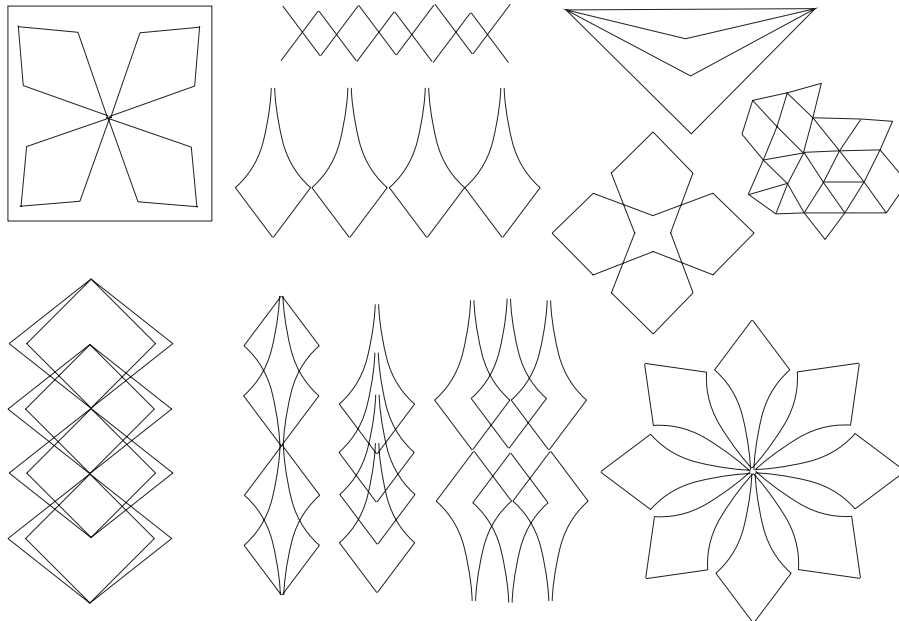

Creative Grids® USA, Inc.
400 W. Dussel Dr. Ste B,
Maumee, OH 43537
www.creativegridsUSA.com

Creative Grids® UK, Ltd.
Unit 23A Pate Road
Leicester Road Industrial Estate
Melton Mowbray
Leicestershire, LE13 0RG England
www.creativegrids.com

Creative Grids® is covered by U.S. Trademark Registration No. 2,796,615

CGRQA11



743285 002818



Dot

By Angela Walters

Dot is like getting two rulers in one, making it an all-around functional tool!

quiltingismytherapy.com

Creative Grids® Grip keeps the ruler in place

Lots of reference lines to ensure that your quilting stays on track!

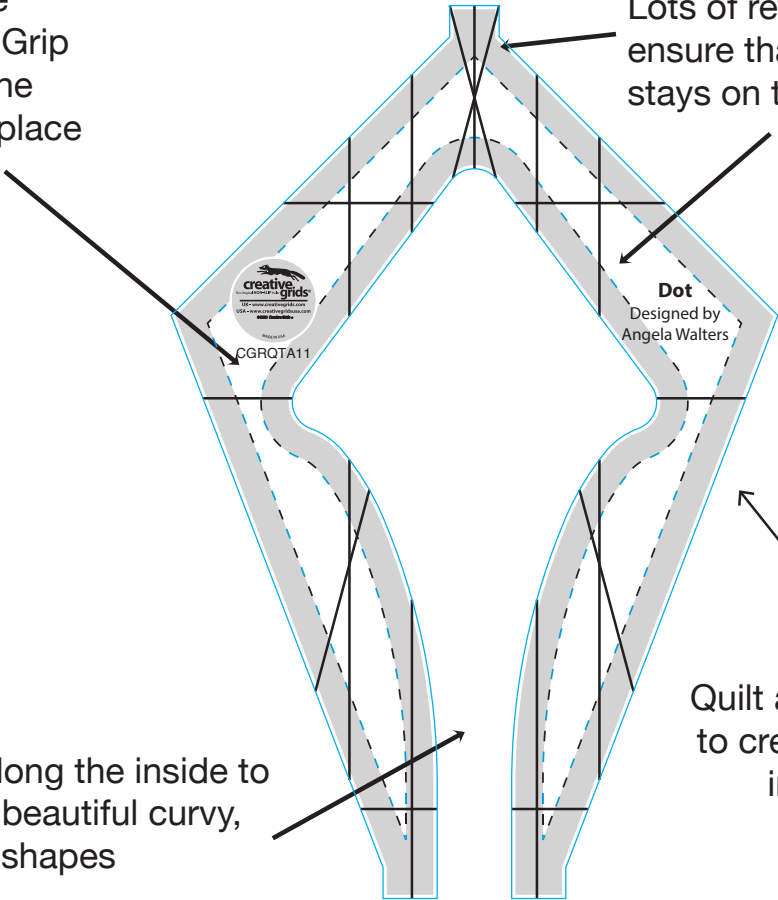

Quilt along the inside to create beautiful curvy, pointy shapes

Quilt along the outside to create straight lines in different angles

Use Dot for:

Geometric Shapes, Motifs, Border Designs, Echoing & More!

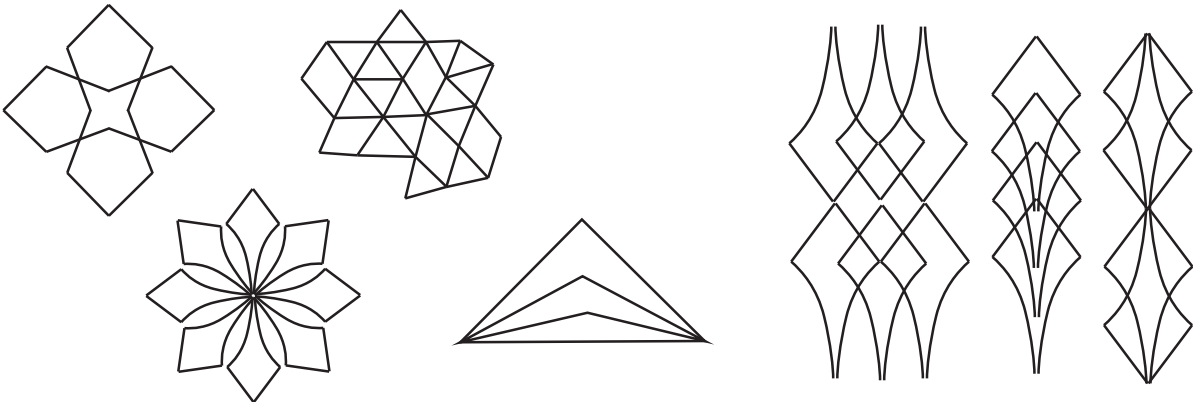

Quilting with the Dot Ruler

Dot

By Angela Walters



Using the Cut Out

Quilt along the inside of the ruler to create some curvy, point shapes.

Position ruler using reference lines to ensure it is straight.

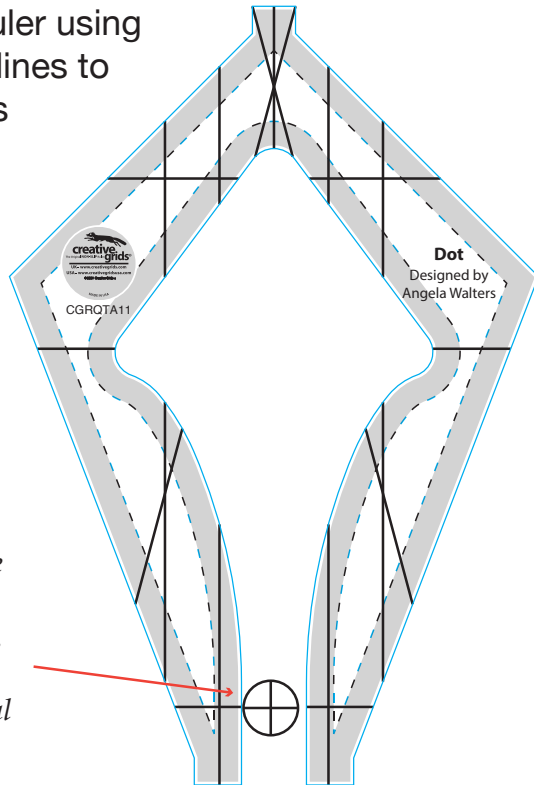

The foot of the machine should be touching the left side of the cut out. Align the needle with the horizontal reference line.

Quilt along the inside of the ruler, starting on the left side and ending on the right side. Stop when the needle is aligned with the bottom reference line.

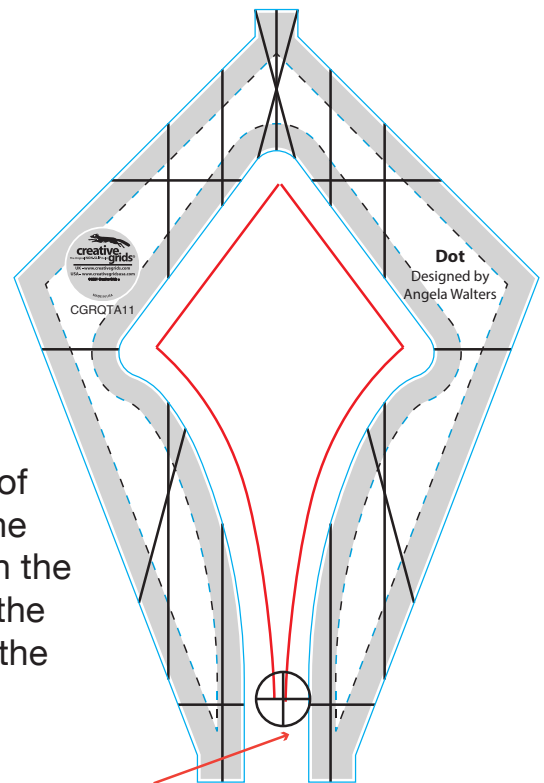

The foot of the machine should be touching the right side of the cut out.

Dot

By Angela Walters

Cut out Motifs

Rotate the ruler to create motifs with the cut out portion of the ruler.

Quilt along the inside of ruler, starting on the left side and ending on the right.

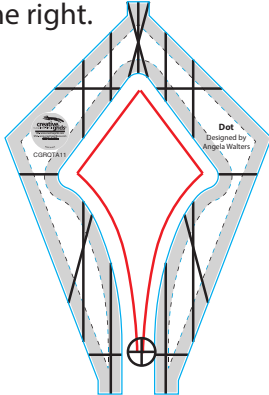

With the needle in the down position, rotate the ruler 90 degrees. Use the reference lines to ensure that it is straight.

The reference line should be lined up with the previous quilting.

The foot of the machine should be along the side of the ruler.

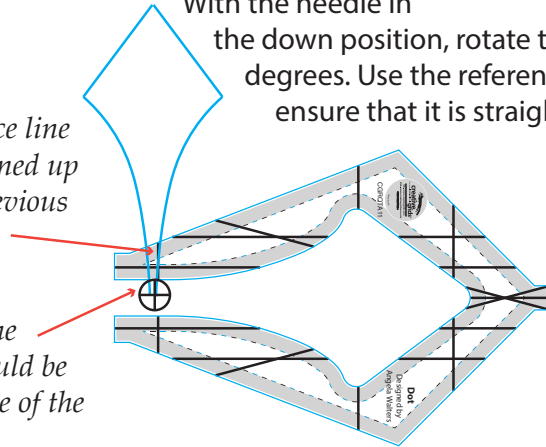

Quilt along the inside of the ruler, starting on the left side and ending on the right side. Stop when the needle is aligned with the bottom reference line.

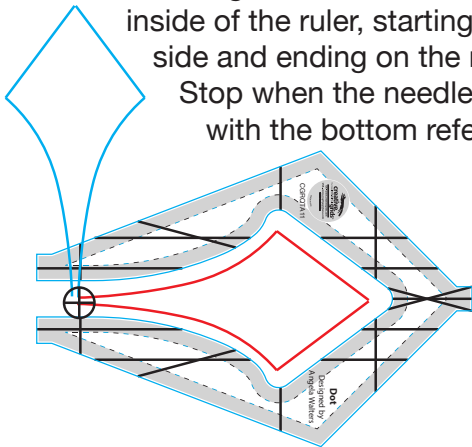

Repeat to quilt two more shapes, rotating the ruler 90 degrees each time.

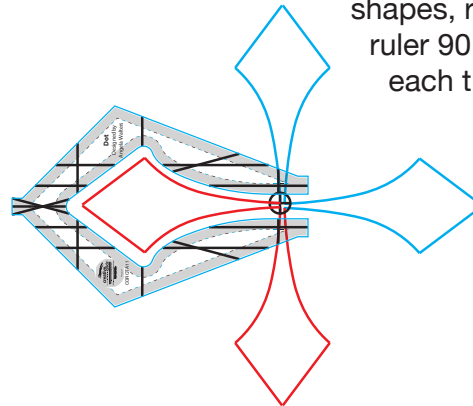

To create an even more complex looking motif, add shapes in between the previously quilted ones.

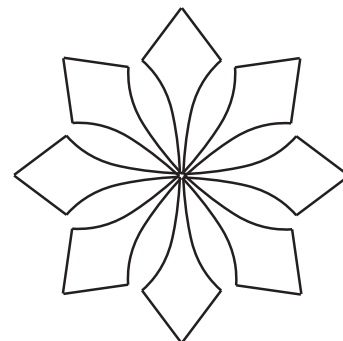
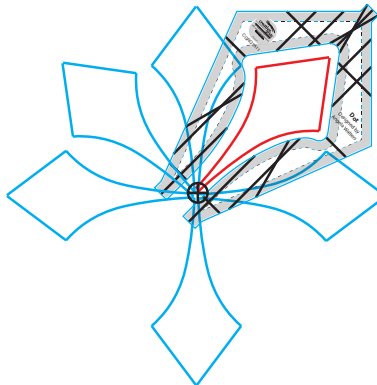
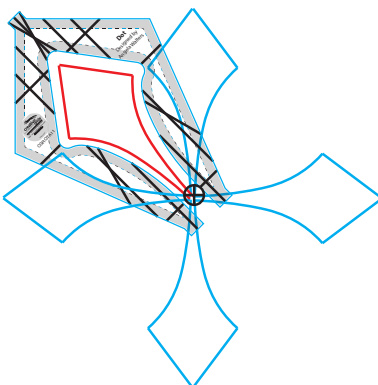

Dot

By Angela Walters

Use the cut out center of the ruler to create a myriad of designs!

Quilt them in a row to create a design perfect for large borders. Line the ruler up with the edge of the area, then quilt along the inside. Travel along the edge, then repeat. The closer you quilt the shapes, the more they will overlap.

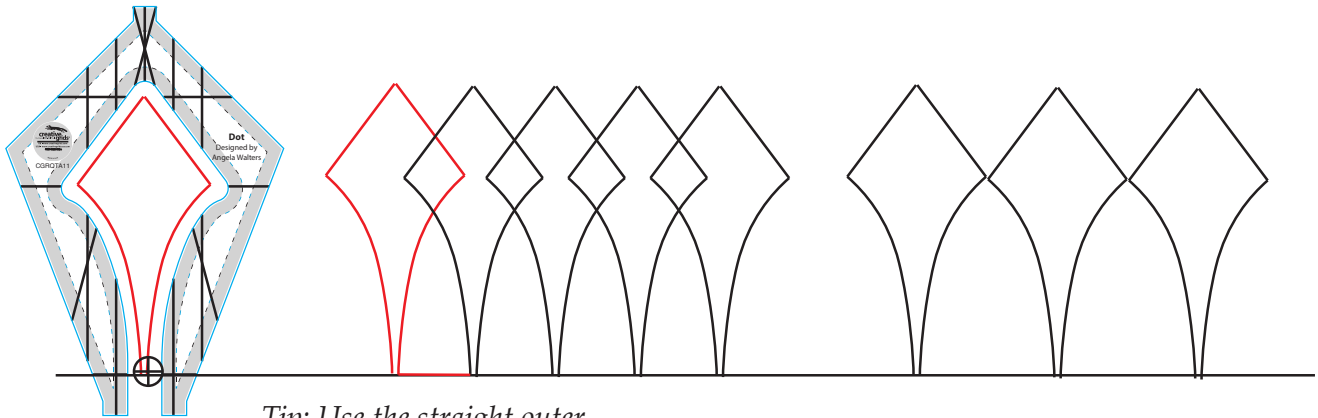

Tip: Use the straight outer edge to travel along the seam.

For an even more complex design, quilt a row of overlapping shapes, then quilt another row that mirrors the first one. Be sure to take your time and use your reference lines to ensure they stay straight.

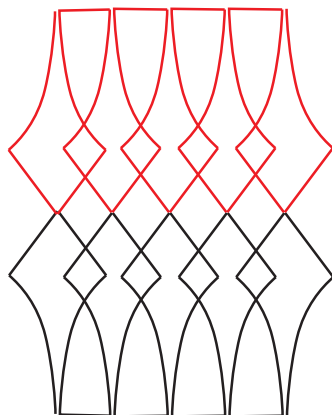

Quilt along the top part of the cutout only to quilt chevrons quickly.

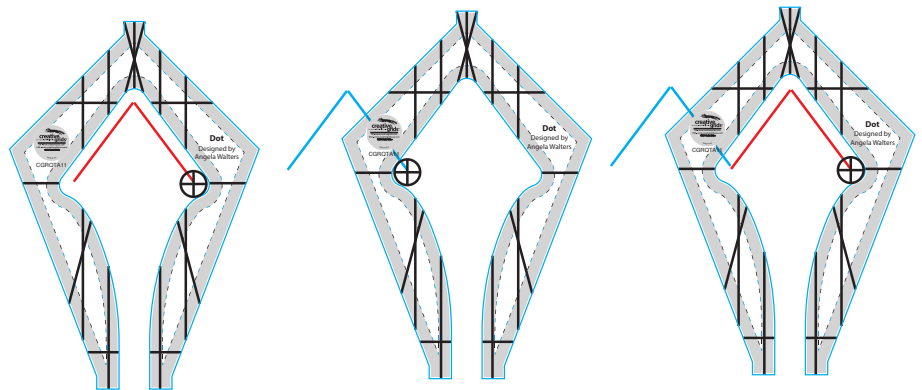

Overlap two rows of chevrons for a diamond border design.

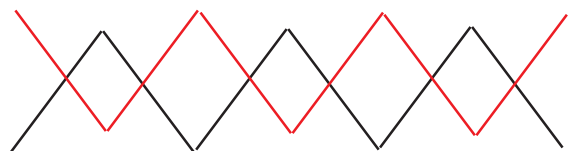

Using the outside

Dot

By Angela Walters

Start with the foot of the machine on one side of the ruler. Align the needle with the bottom reference line.

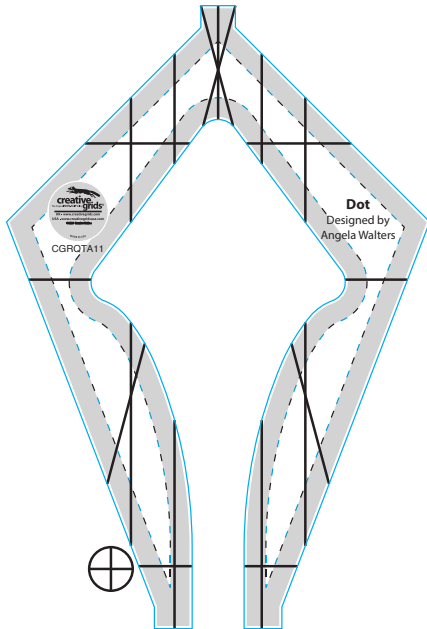

Quilt along the edge of the ruler until the foot is almost to the point.

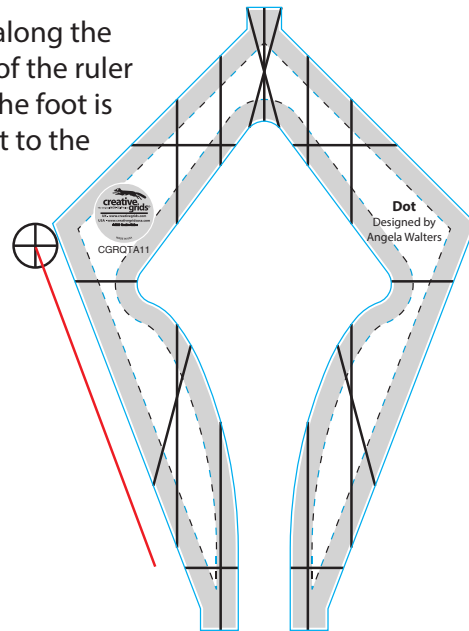

Shift the ruler so that the next edge is against the bottom of the foot.

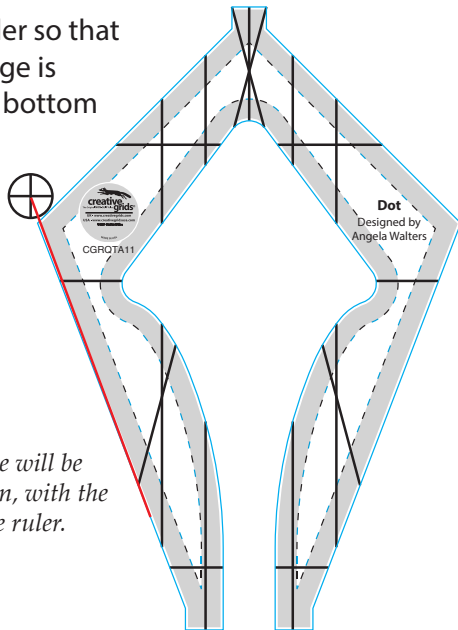

The quilted line will be parallel, or even, with the first edge of the ruler.

Quilt along the edge of the ruler until you reach the needle stop.

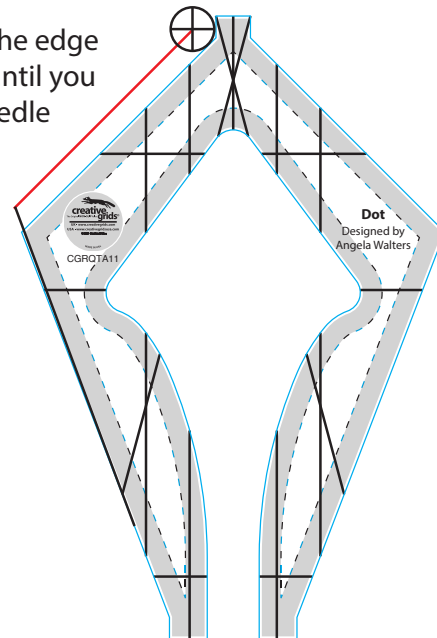

Dot

By Angela Walters

Using the outside

Shift the ruler so that the needle stop is on the opposite side of the foot.

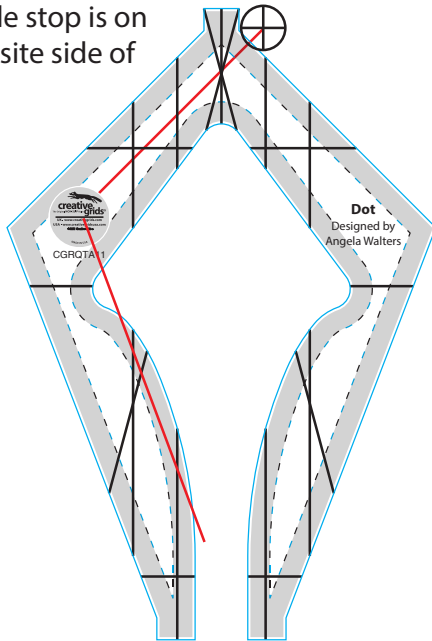

Quilt along the edge of the ruler until the foot is almost to the point.

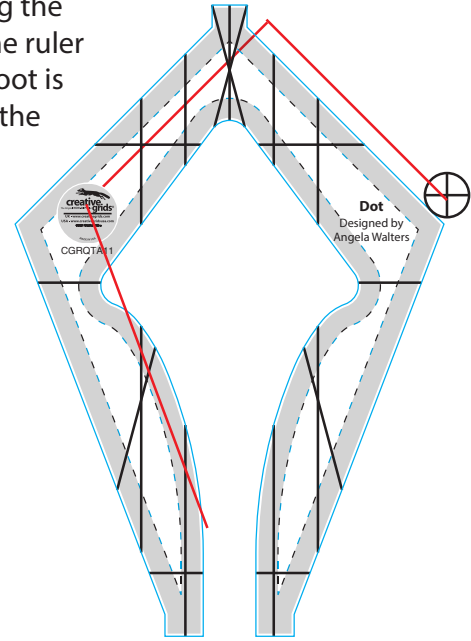

Shift the ruler so that the next edge is against the side of the foot. Then quilt along the edge, stopping at the reference line at the bottom.

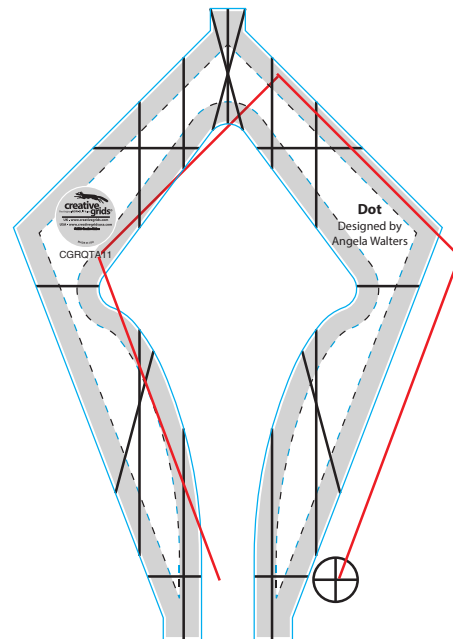
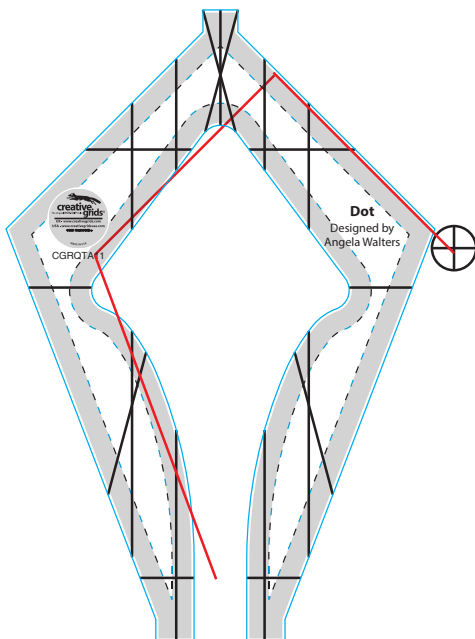



Dot

By Angela Walters

Wedge Designs

Quilt four wedge shapes, rotating each one, to make a motif

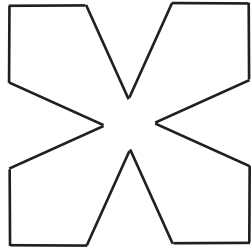

Quilt wedges, alternating directions to make a bigger design.

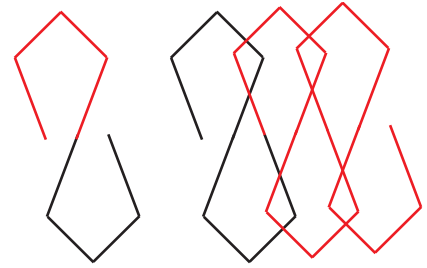

Use the reference lines to make a narrower wedge design. Quilt along the first side as normal, repositioning the ruler when you get to the point.

Quilt along the next edge, stop when the needle is aligned with the first reference point.

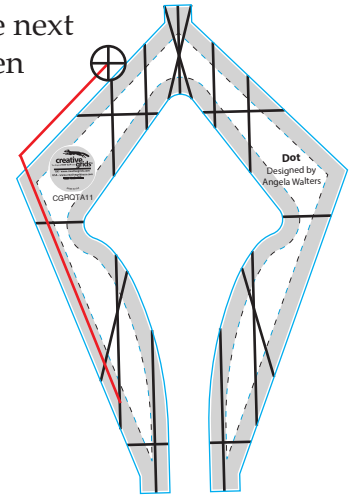
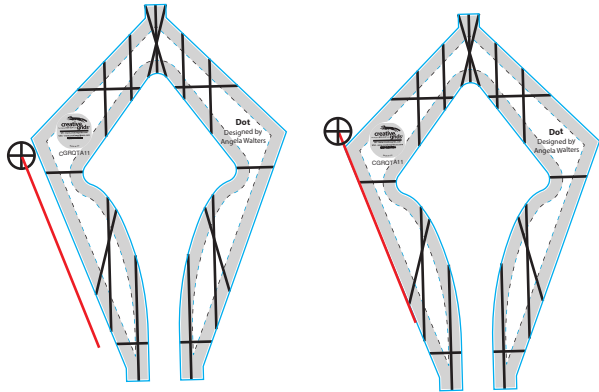

Reposition the ruler so that the needle is above the same reference line on the other side.

Quilt along the edge stopping at the point.

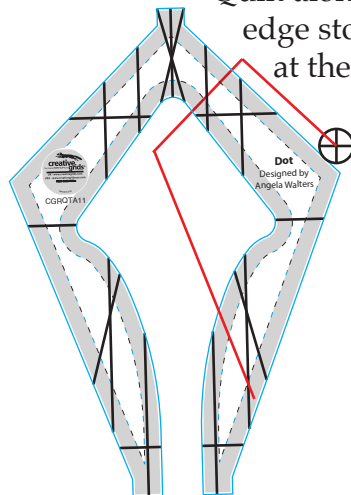
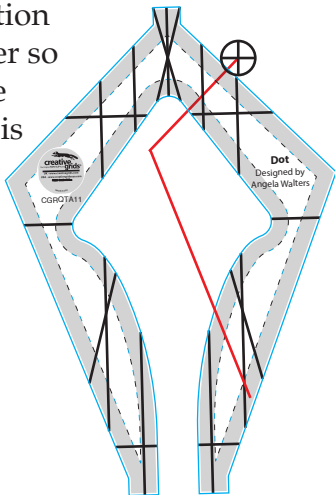

Reposition the ruler and quilt the last line ending at the starting point.

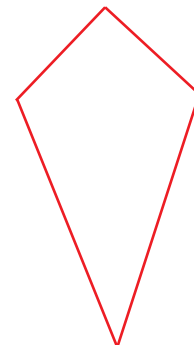
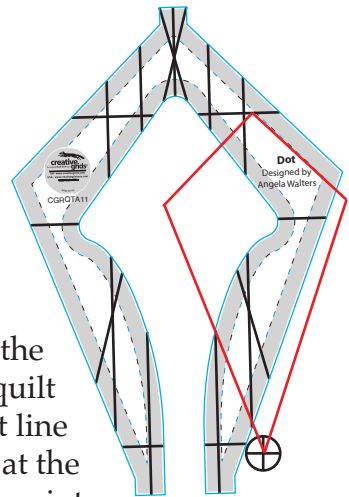

Dot

By Angela Walters

Chevrons

The reference lines on the ruler will help you quilt diagonal lines of different angles.

Align this reference line with the edge of an area (or a marked line.)

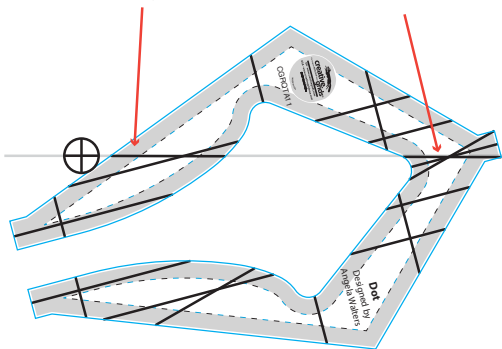

Quilt along the edge, stopping at the point.

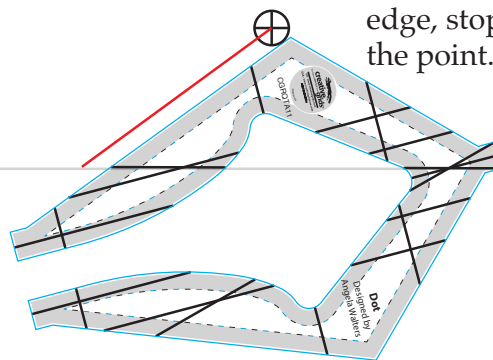

Rotate the ruler so that it angles down. The two reference lines at the bottom of the ruler should line up with the previously quilted line.

Quilt along the edge of the ruler stopping at the edge of the area.

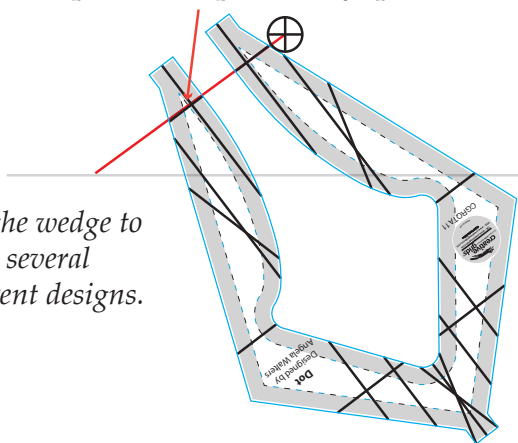

Use the wedge to make several different designs.

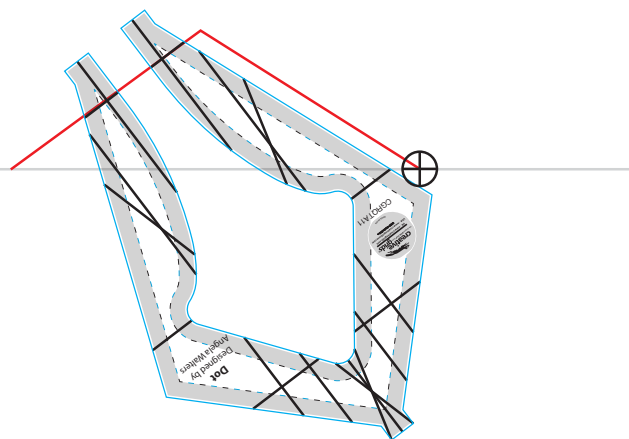

Reposition the ruler and repeat, quilting chevrons.

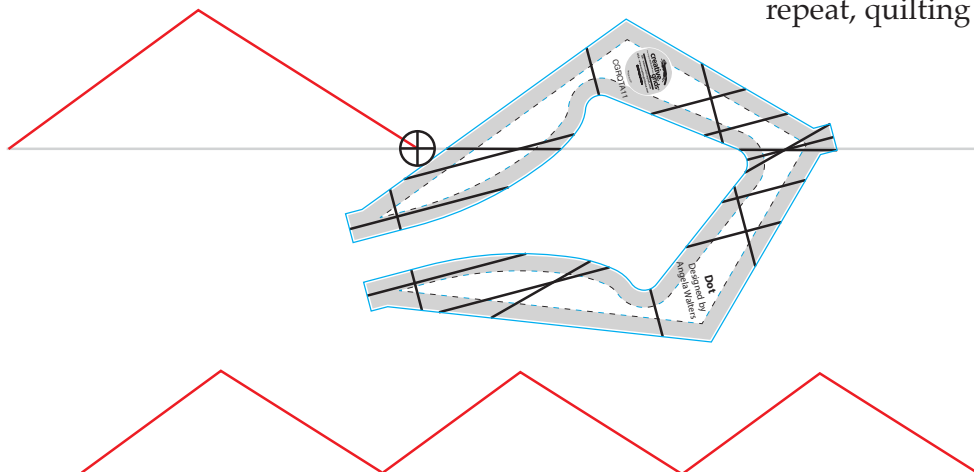

Chevrons

For shorter, wider chevrons, use a different reference line

Align this reference line with the edge of an area (or a marked line.)

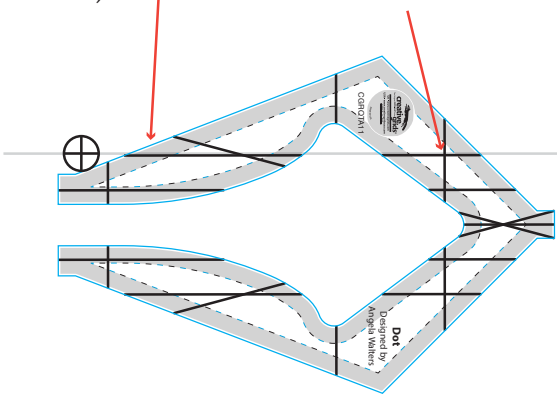

Quilt along the edge, stopping at the point.

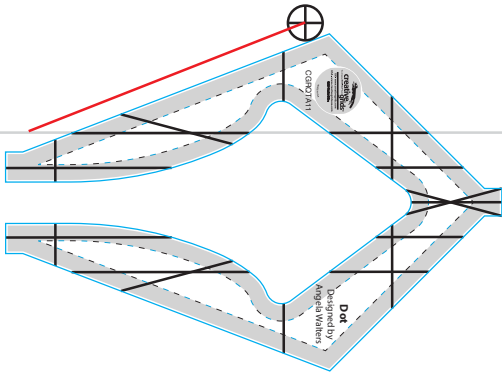

Flip the ruler over and line up the reference line on the seam.

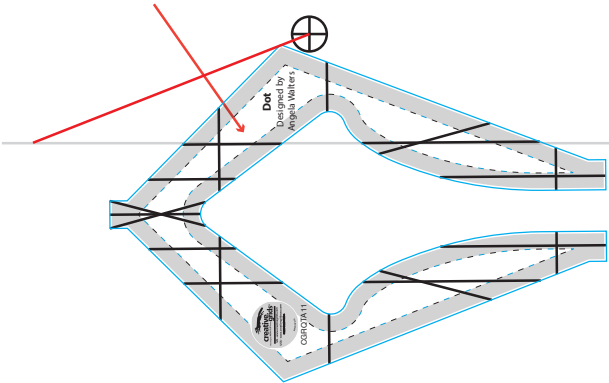

Quilt along the edge of the ruler stopping at the edge of the area.

