

WARNING

- This unit contains small parts which could be a choking hazard for small children. Children should be under adult supervision at all times or serious injury could occur.
- Always unload unit prior to moving the unit. The weight of personal belongings can cause the unit to become unstable and either tip or collapse. Serious bodily injury and/or damage to personal belongings may occur.
- Do not overload unit. If any shelf, top, or bottom of unit bows or bends, it is overloaded. The shelf, top, or bottom could collapse and cause serious bodily injury and/or damage to personal belongings.
- Do not climb or step on the unit.

The unit may become unstable and either tip or collapse. Serious bodily injury and/or damage to personal belongings may occur.

- Do not use this unit as a television stand. Serious bodily injury and/or damage to personal belongings may occur.
- Do not mount or attach anything to the sides, rear or front of the unit as this can create a force which can cause the unit to tip. Serious bodily injury and/or damage to personal belongings may occur.
- Do not stack units. Stacking of units can cause an unsafe tip-over hazard which may cause serious bodily injury and/or damage to personal belongings.
- Do not hang this unit on the wall. The product structure is not designed for wall hanging. Serious bodily injury, damage to personal belongings, and/or damage to the wall may occur.
- Follow proper safety procedures when using power tools and ladders.
- We recommend you protect your work surface during assembly to prevent scratching or damage to table tops, wood floors, etc.

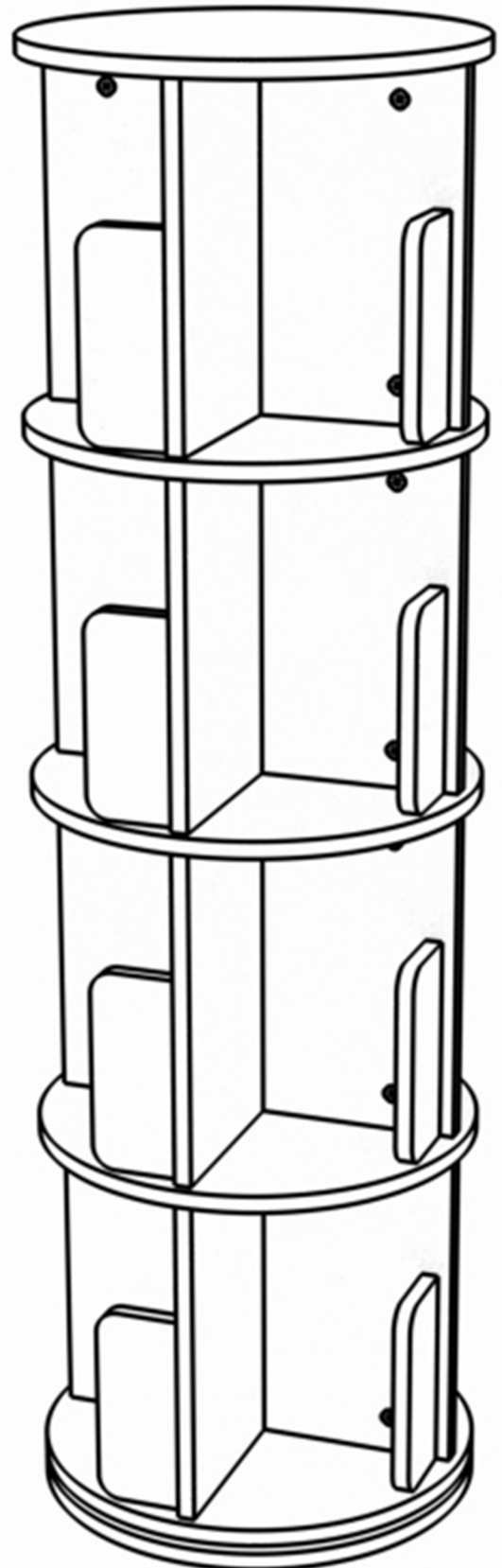

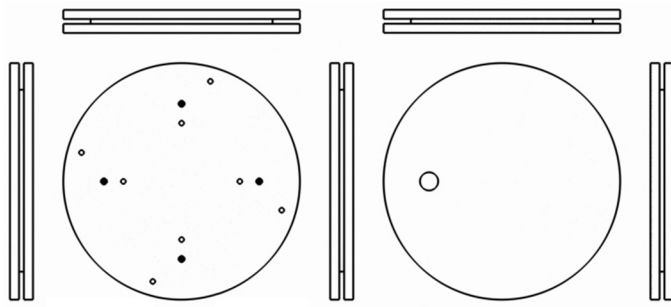

A

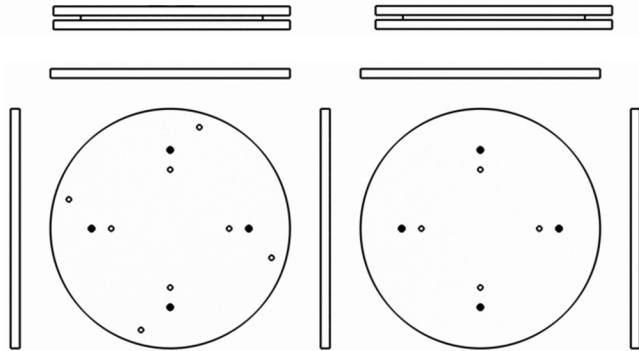

B

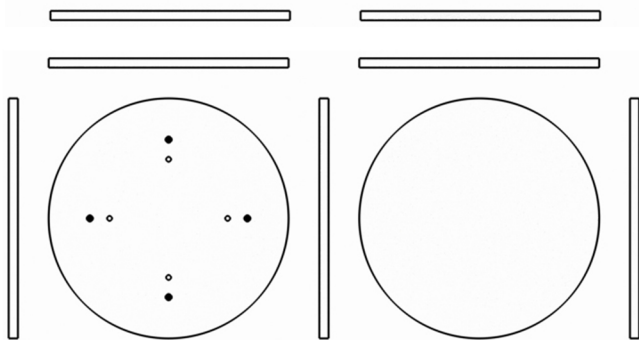

C

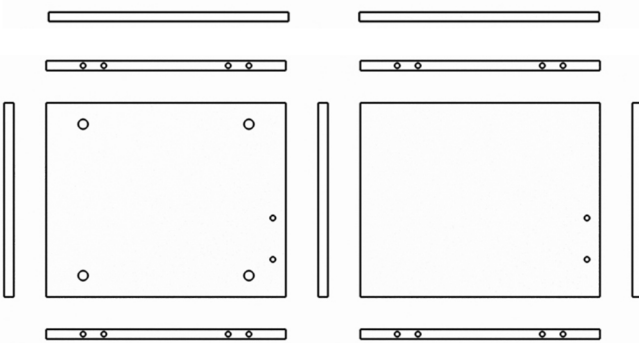

D

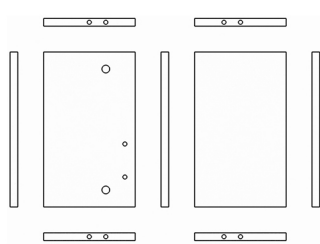

E

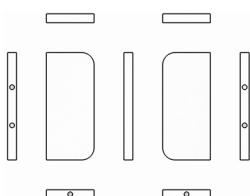

F

Ⓐ x1

Ⓑ x3

Ⓒ x1

Ⓓ x4

Ⓔ x8

Ⓕ x16

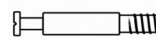

G



H



I

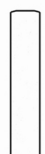

J

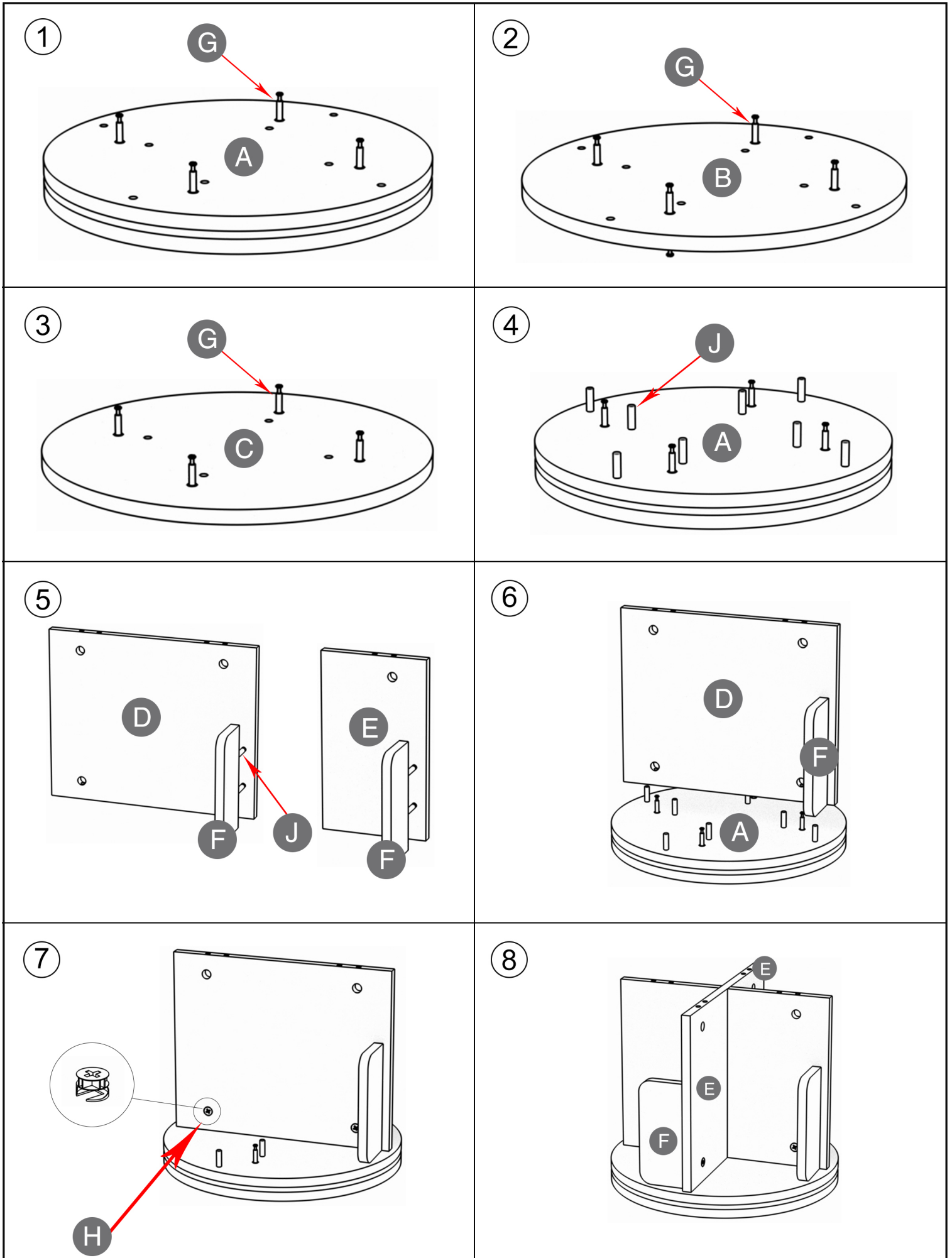

9

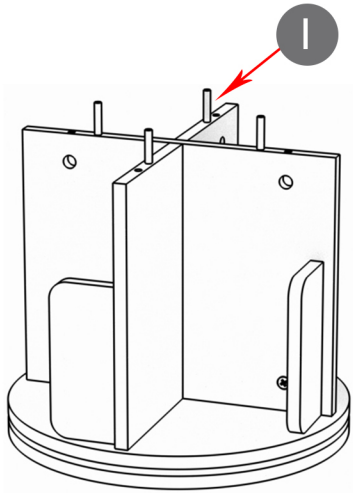

10

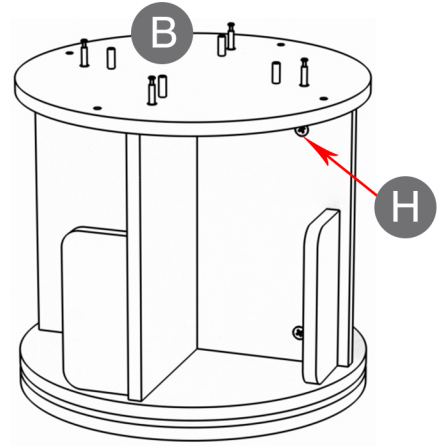

11

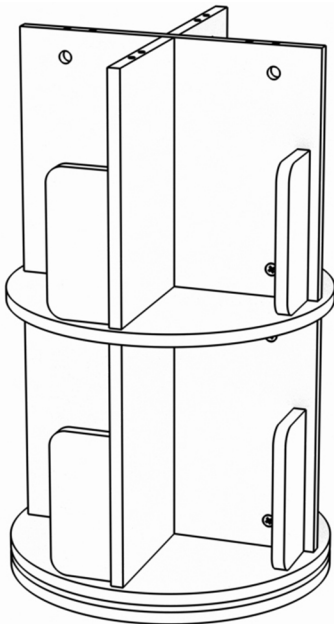

12

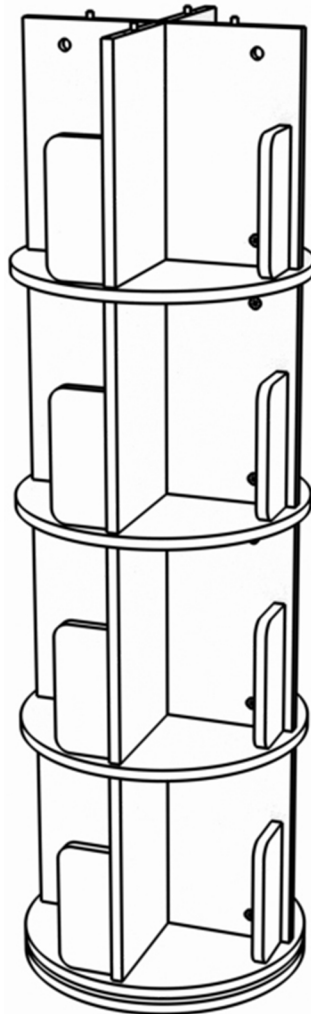

13

