

4. Adjustments



WARNING
Before adjusting, ALWAYS turn the motor switch OFF and check that the motor has already stopped.

4.1 Needle thread tension

- (1) As standard, set the needle bar at the highest point. And set the part "a" horizontally when the needle thread take-up ① is at the extreme right. Loosen the screws ② and move the needle thread take-up ① to adjust it.
 - To tighten the needle thread, move it in the direction "X".
 - To loosen the needle thread, move it in the direction "Y".
 - (2) As standard, move the needle thread eyelet ④ at the extreme right. If not enough for adjustment (1), loosen the screw ③ and move the needle thread eyelet ④ to adjust it.
 - To tighten the thread tension, move it in the direction "X".
 - To loosen the thread tension, move it in the direction "Y".
 - (3) As standard, set the needle thread eyelet ⑤ at the lowest point. After adjustments (1) and (2), adjust as below to loosen the needle thread further. Loosen the screw ⑥ and move the needle thread eyelet ⑤ to adjust it.
 - To tighten the needle thread, move it in the direction "X".
 - To loosen the needle thread, move it in the direction "Y".
- Use the needle thread guide when a needle thread loop is formed unstably with using stretchable thread like a synthetic thread.
- As standard, set the needle bar at the lowest point. And set the center of the needle bar thread eyelet ⑦ eye even with the top of the needle thread guide ⑧ and set them in parallel.
- Loosen the screw ⑨ to adjust the height and left-and-right position of the needle thread guide ⑩.

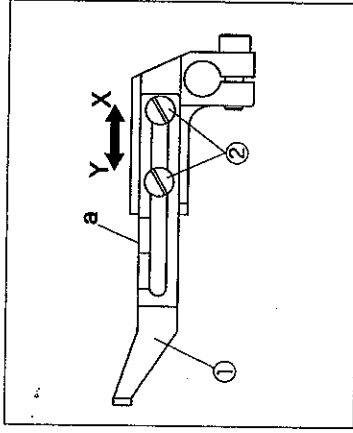

Fig. 15

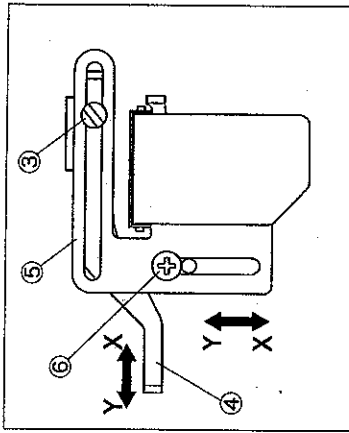

Fig. 16

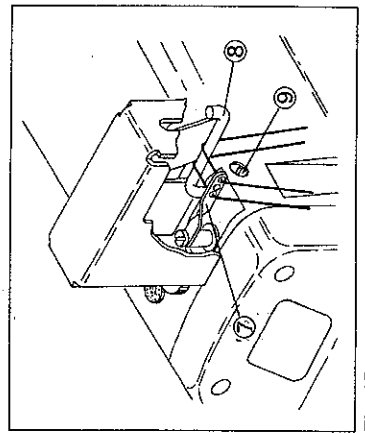
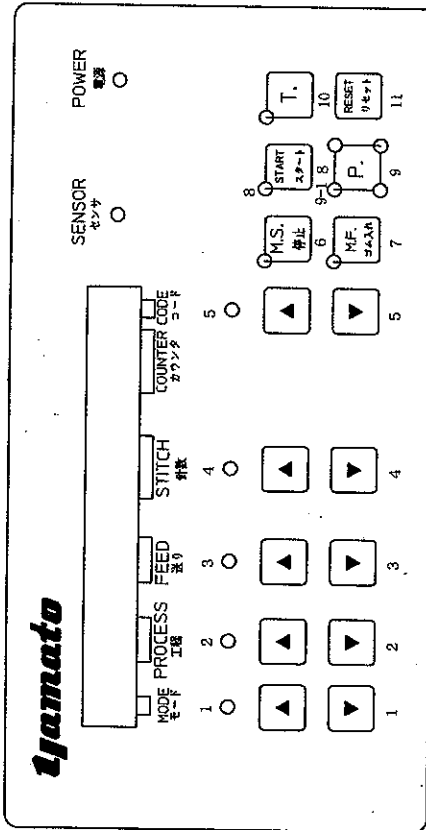

Fig. 17

3. Proper operation



Display

B 01 30 000 A
B 01 30 000 A
B 01 30 000 000 A
B 01 29 000 000 A
B 02 05 050 000 B
B 03 31 000 000 A
B 03 35 000 000 A
B 04 35 000 000 A
B 04 37 000 000 A
B 05 04 050 000 B
B 06 34 000 000 A
B 06 32 000 000 A
B 01 29 000 000 A

25. Set the process to "1" by Switch 2.
26. Set the starting state by Switch 7.
27. Place a fabric and sew in Process 1. Set the proper feeding amount to "29" by Switch 3 while sewing.
28. Shift to Process 2 by pressing the knee switch. Set the proper feeding amount to "05" by Switch 3 while sewing.
29. After count up, it shifts to Process 3 automatically.
30. Set the proper feeding amount to "35" by Switch 3 while sewing.
31. Shift to Process 4 by pressing the knee switch.
32. Set the proper feeding amount to "37" by Switch 3 while sewing.
33. Shift to Process 5 by pressing the knee switch.
34. After count up, it shifts to Process 6 automatically.
35. Set the proper feeding amount to "32" by Switch 3 while sewing.
36. Press the knee switch to finish the sewing.
37. Check that the stitch number is proper. If not, re-set proper value.

After that, press the knee switch after finishing each Process 1, 3, 4, and 6 to sew the fabrics.

3.4 Designations and functions of control panel (only for VF2429-8, VF2529-8)

This model has modes A - Z and each mode can be subdivided into 20 processes.
Set one mode corresponding one piece of fabric and one process depending on the tension amount of a tape on its fabric.

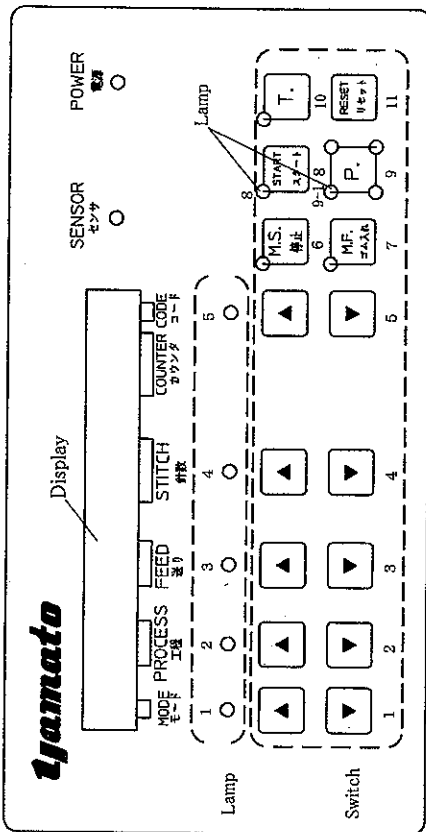

3.4.1 Details of control panel

- (1) Display
Numbers and alphabets are displayed to show the current control condition.
- (2) Lamp (1, 2, 3, 4, and 5)
The switch under the lit lamp can be functioned.
- (3) Switch
For the following switches, pressing ▲ increases the value and pressing ▼ decreases it.
 - ☆ Switch 1 (Mode)
Select the mode A - Z.
 - ☆ Switch 2 (Process)
Set the process 1 - 20. Feeding amount, stitch number, and the code in the process are displayed.
 - ☆ Switch 3 (Feeding)
Set the feeding amount. Keep pressing it will increase or decrease the value automatically.
 - ☆ Switch 4 (Stitch number)
Set the stitch number. Keep pressing it will increase or decrease the value automatically.

What is process? What is mode?

Process: to sew a fabric under preset conditions (feeding, stitch number)
Mode: to sew a part of fabric with some combined processes.

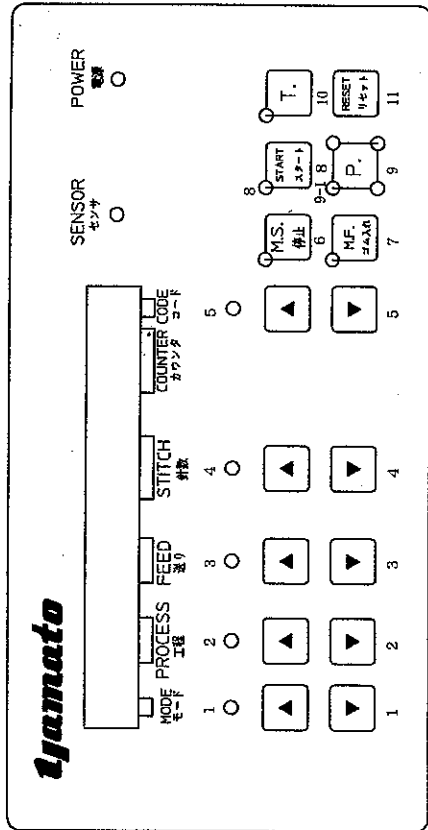

☆ Switch 5 (Code)

Set the code to proceed the program.
Select the code depending on the function.
Code A: Press the knee switch to shift the next process.
Code B: After sewing preset stitch number, the sewing shifts to the next process automatically. It shows which number of stitch at the process on the counter display during sewing.

Code C: Return to 1st Process.

Be sure to set Code C when 3rd Process for Process 2 fabrics and when 7th Process for Process 6 fabrics.

☆ Switch 6, 7

Not used.

☆ Switch 8 (Start)

Pressing this switch will light Lamp 8. (Also When the power switch turns on, it will light.)

Only in this state, sew the fabrics and change the feeding amount.

☆ Switch 9 (P.)

When the machine stops, pressing this switch will light Lamp 9-1.

Only in this state, change mode, process, feeding amount, stitch number, and code.

☆ Switch 10

Not used.

☆ Switch 11 (Reset)

When the machine stops, pressing this switch will return to 1st Process.

(4) Sensor lamp

Not used.

(5) Power lamp

This lamp lights when the power turns on.

3. Proper operation

3.4.2 Feeding amount

Table 3 shows feeding tape length of stepping motor (mm/stitch) when setting feeding amount from "00" to "99".

Adjust the feeding amount by Switch "S1" on the control box.

OFF: to adjust standard feeding tape length

ON: to adjust feeding tape length shorter

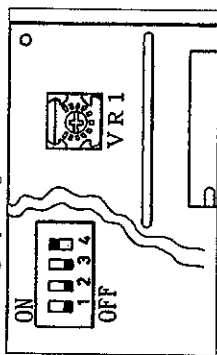

Feeding amount	Feeding length (mm)	
	S1 : OFF	S1 : ON
00	1.00	0.36
20	1.63	1.00
40	2.26	1.63
60	2.89	2.26
80	3.52	2.89

Table 3

3.4.3 Example of application

(Ex. 1) When sewing waist at one process, program by the keys as below.

The machine has been adjusted the same as shown in the right at shipment.

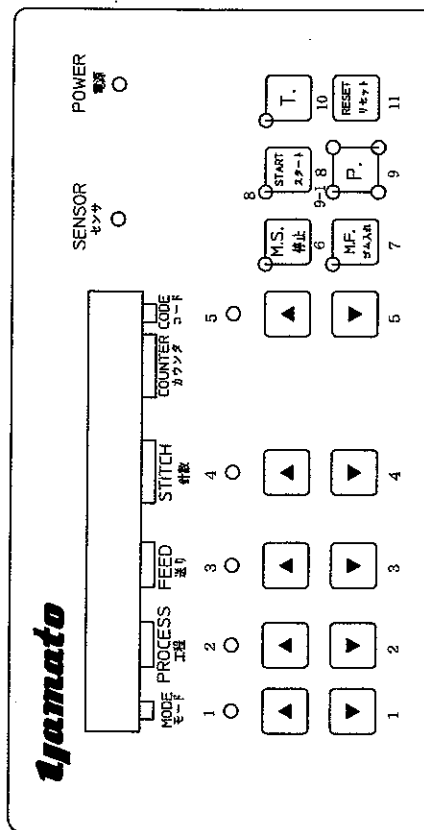
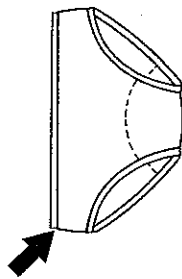

Display

A 01 30 000 000 A
 A 01 30 000 A
 A 01 30 000 A
 A 01 30 000 000 A
 A 01 30 000 000 A

1. Set the process to "1" by reset switch (Switch 11).
2. Set it the programming state by Switch 9.
3. Set the code to "A" by Switch 5.
4. Set it the starting state by Switch 8.
5. Set the proper feeding amount to "30" by Switch 3 while sewing.
6. Finished.

* After that, place a fabric and start sewing.

3. Proper operation

(Ex. 2) When sewing both of the leg parts, make it flat in Processes 1, 3, 4, and 6 and gathering in Processes 2 and 5. Set the stitch number by setting code B in Processes 2 and 5. (Set the feeding amount and the stitch number to the standard value respectively.)

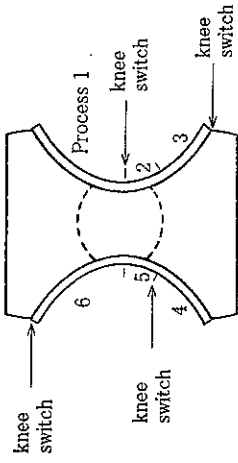

Display

A 01 30 000 000 A
 A 01 30 000 A
 B 01 00 000 A
 B 01 30 000 A
 B 01 30 000 A
 B 02 00 000 A
 B 02 05 000 A
 B 02 05 050 A
 B 02 05 050 B
 B 03 00 000 A
 B 03 31 000 A
 B 03 31 000 A
 B 04 00 000 A
 B 04 35 000 A
 B 04 35 000 A
 B 05 00 000 A
 B 05 04 000 A
 B 05 04 050 A
 B 05 04 050 B
 B 06 00 000 A
 B 06 34 000 A
 B 06 34 000 A
 B 07 00 000 A
 B 07 00 000 C

1. Set the process to "1" by Switch 11.
2. Set it the programming state by Switch 9.
3. Set the mode to "B" by Switch 1.
4. Set the feeding amount to "30" by Switch 3.
5. Set the code to "A" by Switch 5.
6. Set the process to "2" by Switch 2.
7. Set the feeding amount to "05" by Switch 3.
8. Set the stitch number to "050" by Switch 4.
9. Set the code to "B" by Switch 5.
10. Set the process to "3" by Switch 2.
11. Set the feeding amount to "31" by Switch 3.
12. Set the code to "A" by Switch 5.
13. Set the process to "4" by Switch 2.
14. Set the feeding amount to "35" by Switch 3.
15. Set the code to "A" by Switch 5.
16. Set the process to "5" by Switch 2.
17. Set the feeding amount to "04" by Switch 3.
18. Set the stitch number to "050" by Switch 4.
19. Set the code to "B" by Switch 5.
20. Set the process to "6" by Switch 2.
21. Set the feeding amount to "34" by Switch 3.
22. Set the code to "A" by Switch 5.
23. Set the process to "7" by Switch 2.
24. Set the code to "C" by Switch 5.

* All programs have been input completely.

* Then, start a trial sewing.