

SIRUBA®

銀箭牌工業用縫紉機

INDUSTRIAL SEWING MACHINE

FA007

使用說明與零件圖

INSTRUCTION AND PARTS LIST

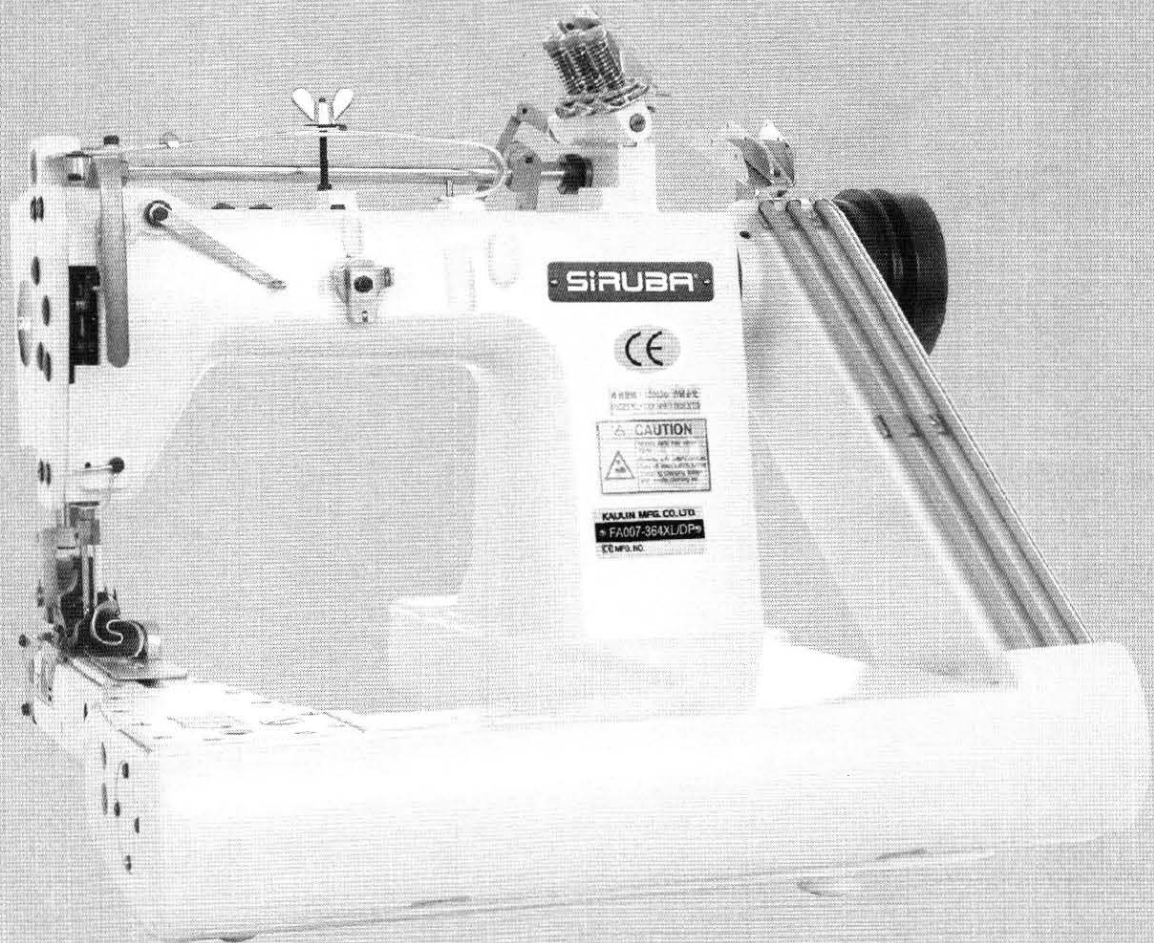

CE



高林股份有限公司
KAULIN MFG. CO., LTD.

From the library of: Superior Sewing Machine & Supply LLC

CONTENTS目錄

CO-MACHINE BODY	1
機體下拉布輪	
C1-UPPER SHAFT MACHANISM	3
上軸結構	
C2-NEEDLE BAR MECHANISM-FEED MECHANISM	5
針柱與送布傳動結構	
C3-PULLY MECHANISM	7
皮帶傳動結構	
C4-PRESSER BAR MECHANISM	9
壓腳柱結構	
C5-LOOPER MECHANISM	11
彎針傳動結構	
C6-UPPER THREADING MECHANISM.....	13
上導線張力結構	
C7-LOWER THREADING MECHANISM.....	15
下導線張力結構	
C8-LOWER SHAFT MECHANISM-GAUGE PARTS(SM1/4).....	17
下軸結構與針位組	
C8-LOWER SHAFT MECHANISM-GAUGE PARTS(SM3/16).....	19
下軸結構與針位組	
C10-GAUGE PARTS (DP) DP.....	21
針位組	
C11-PULLER DEVICE MECHANISM DP	23
上拉布輪結構	
C12-ACCESSORIES.....	25
配件	

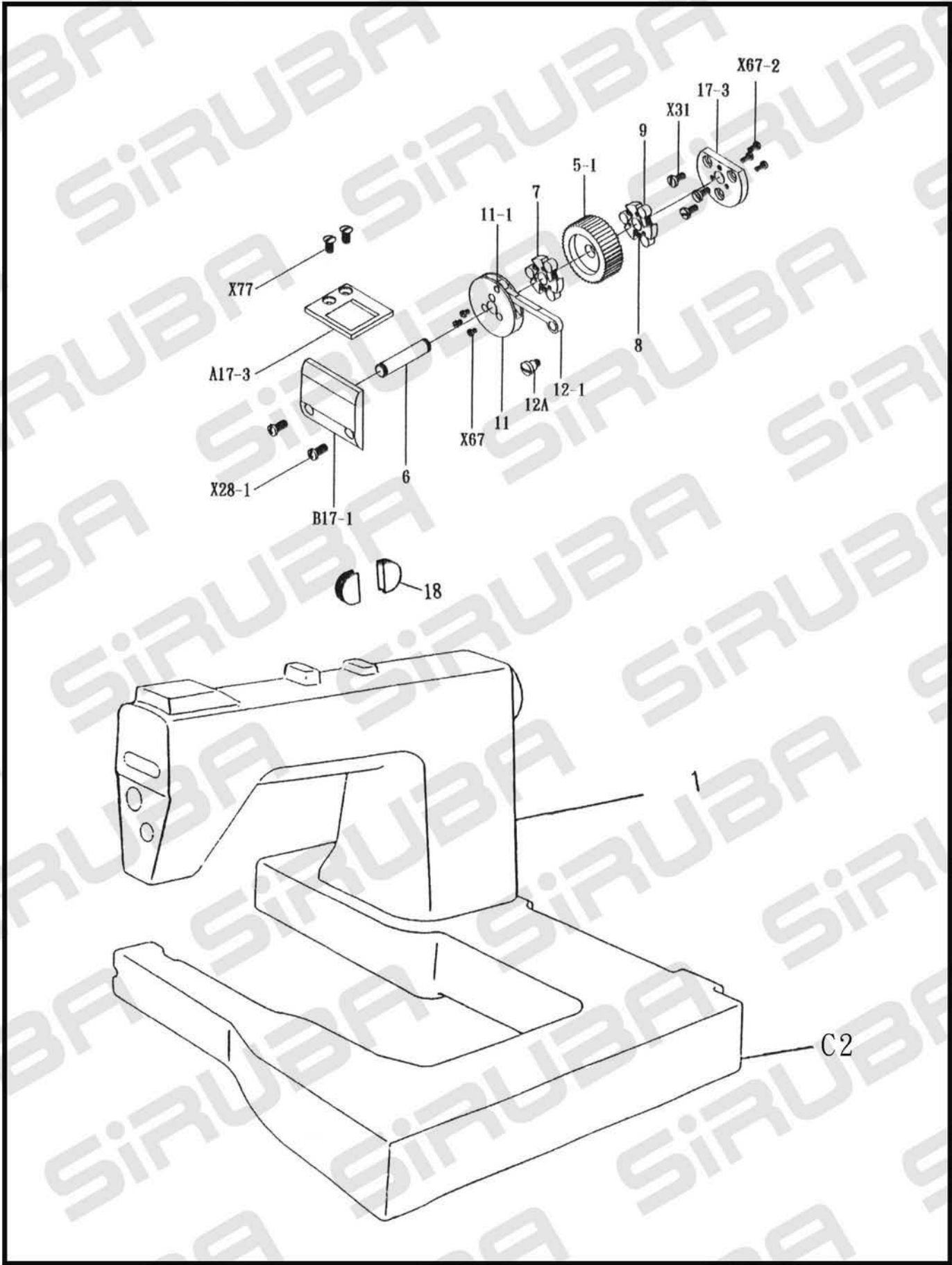

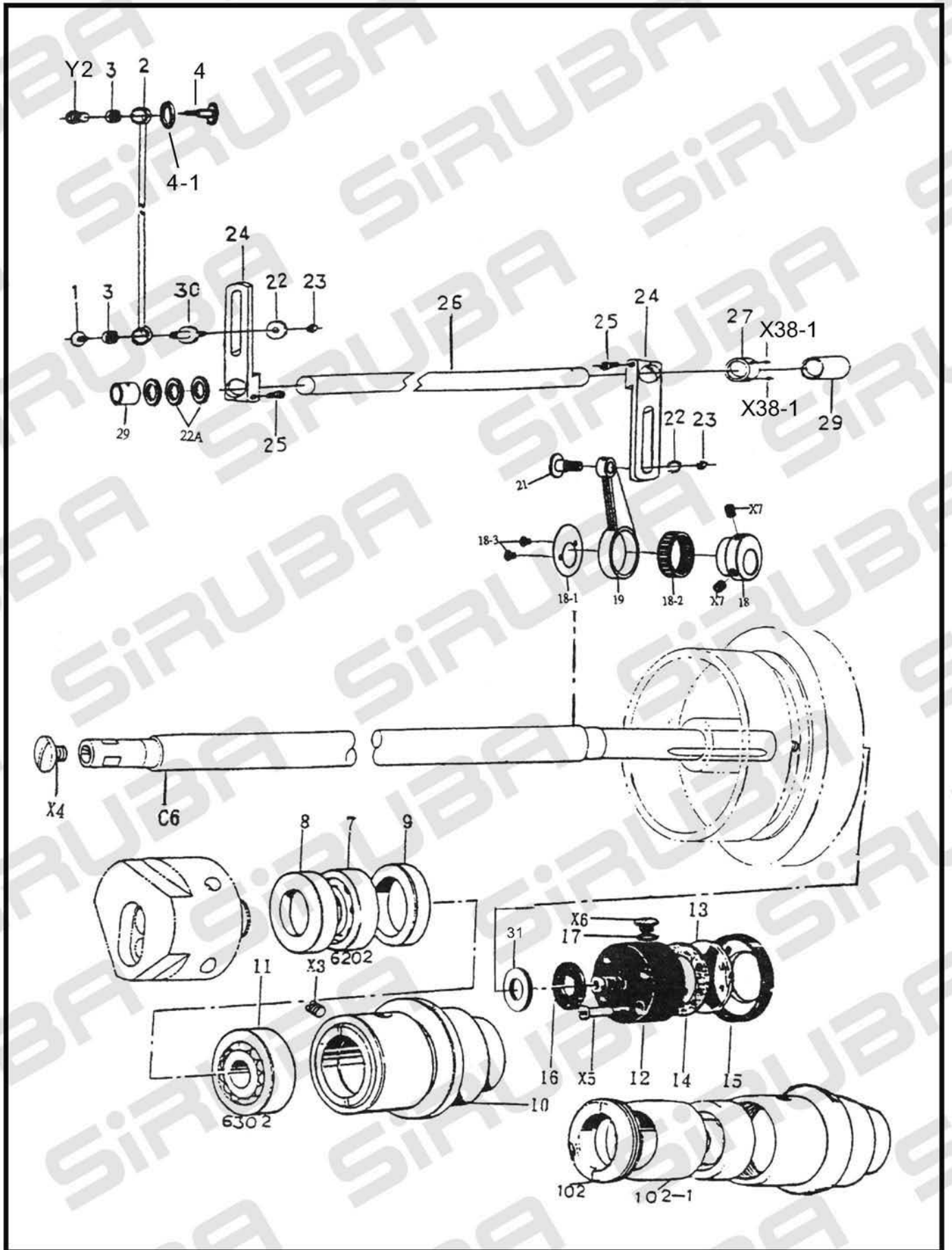

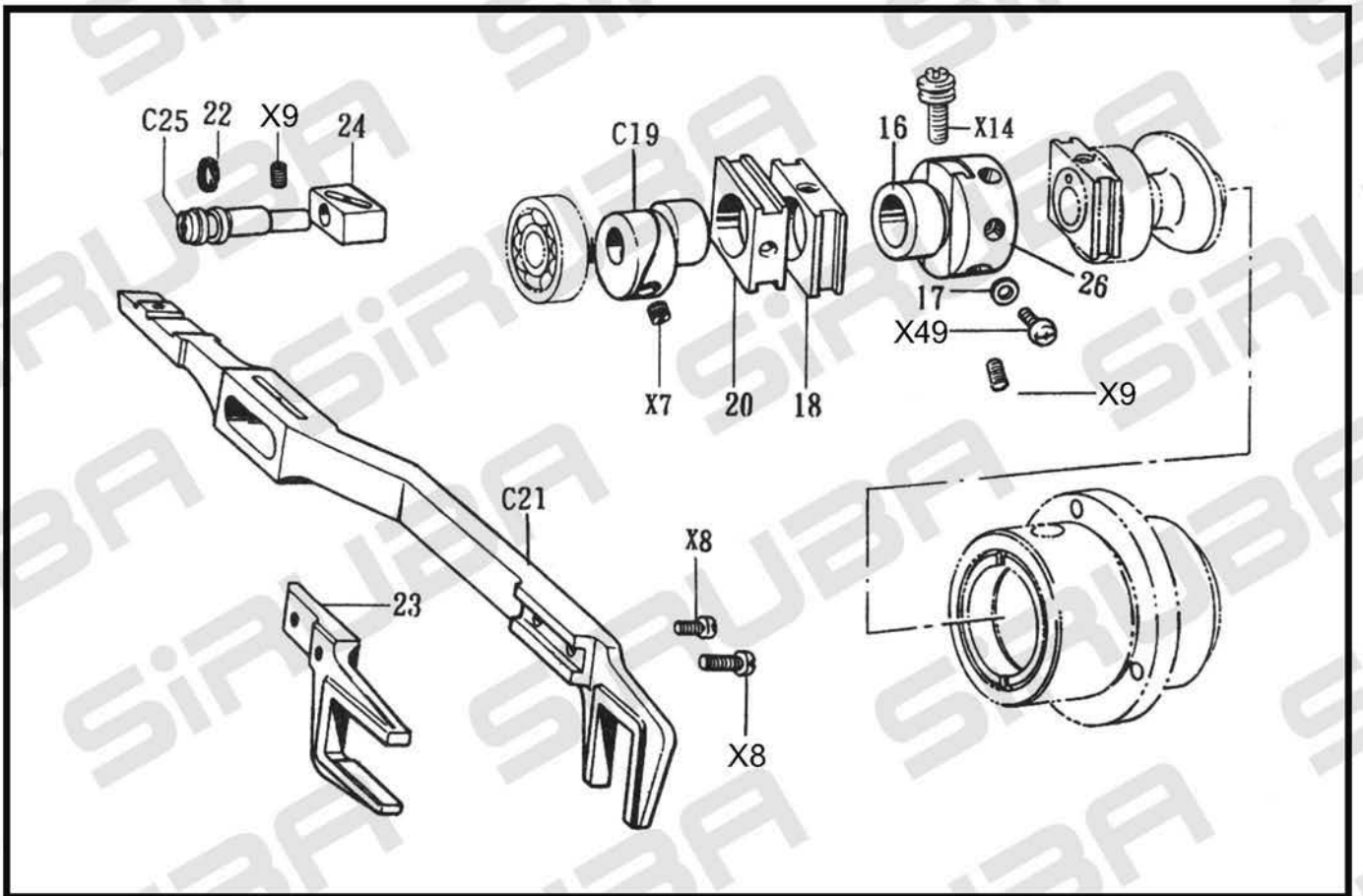
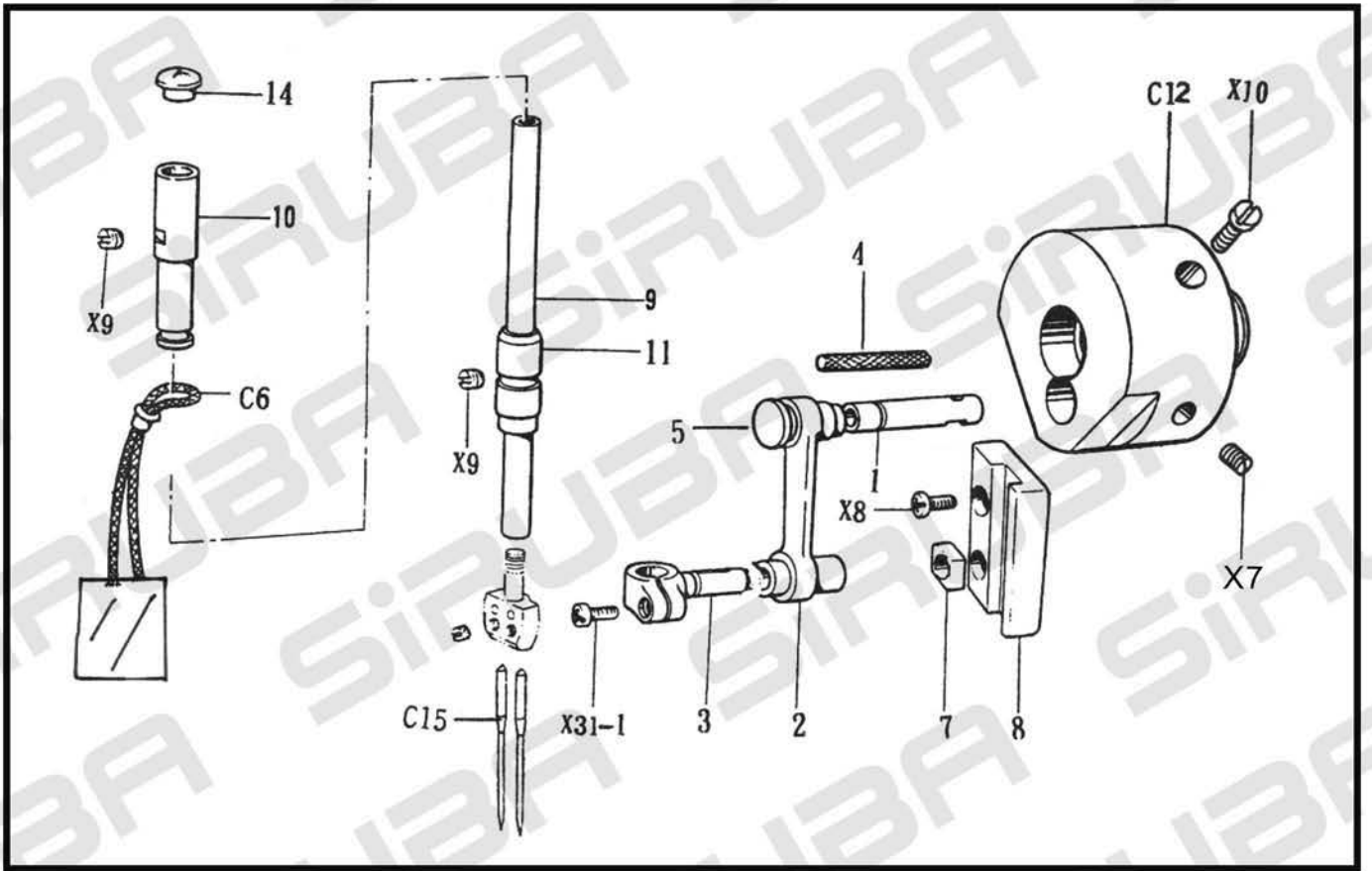

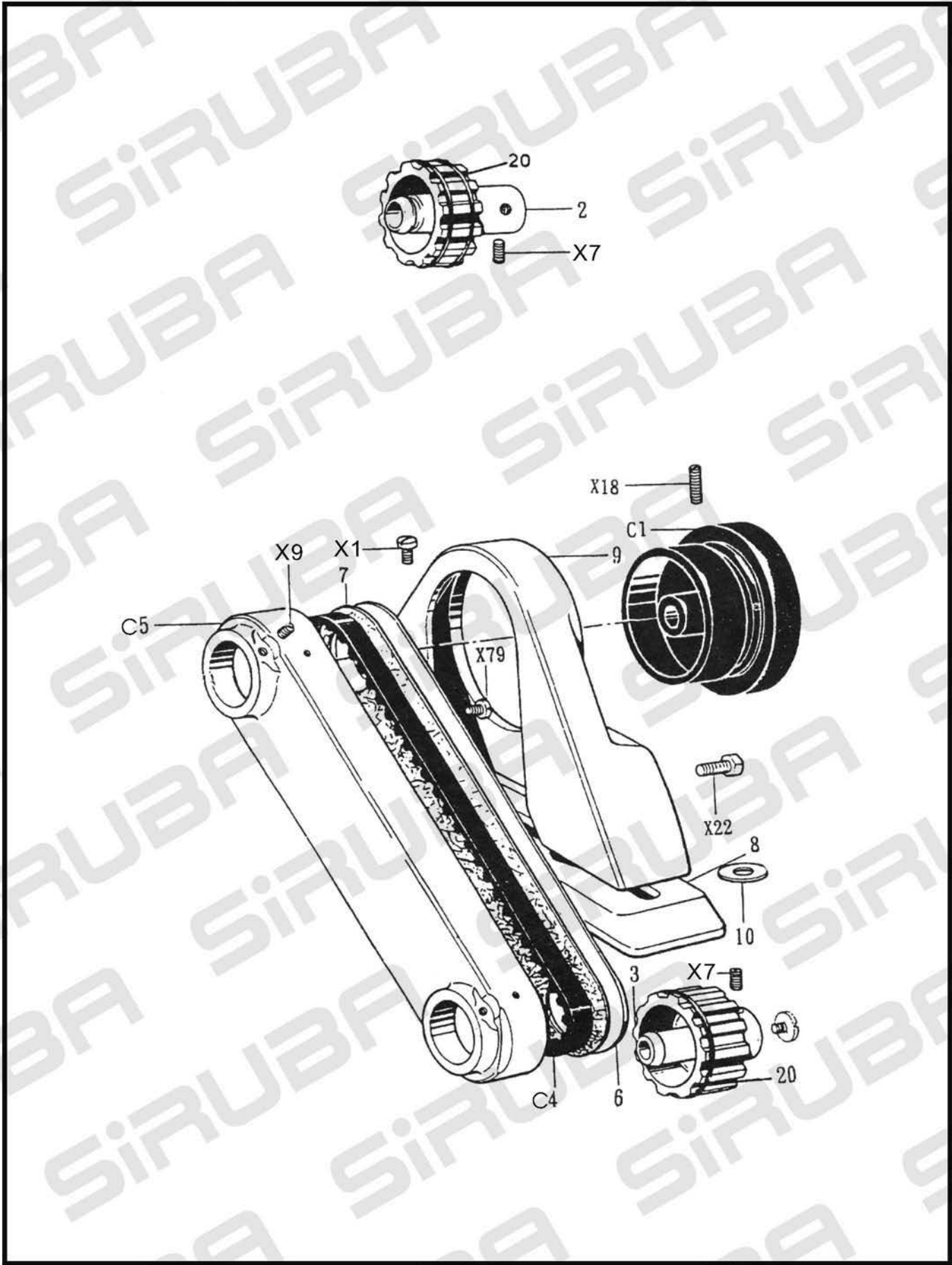

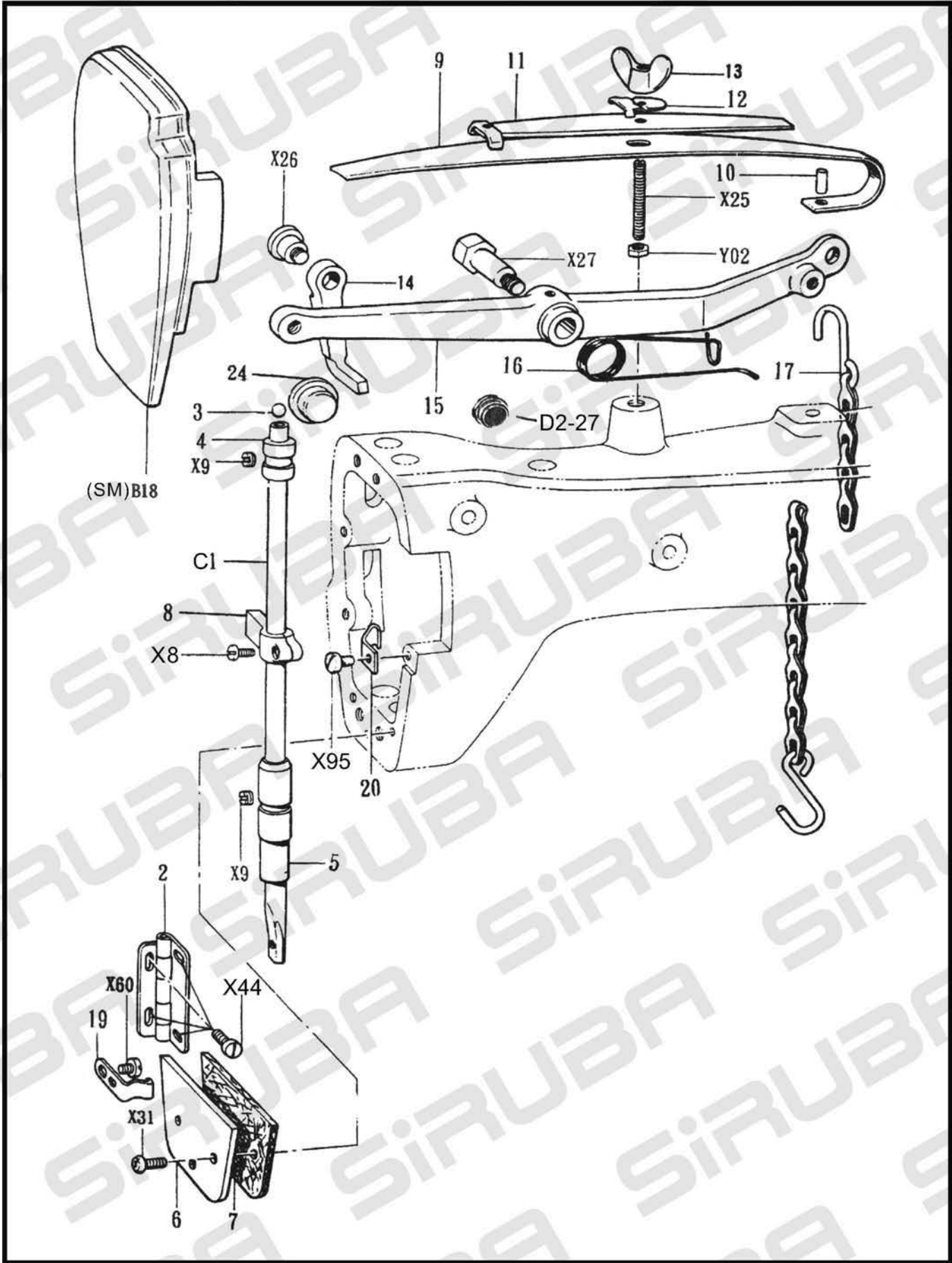

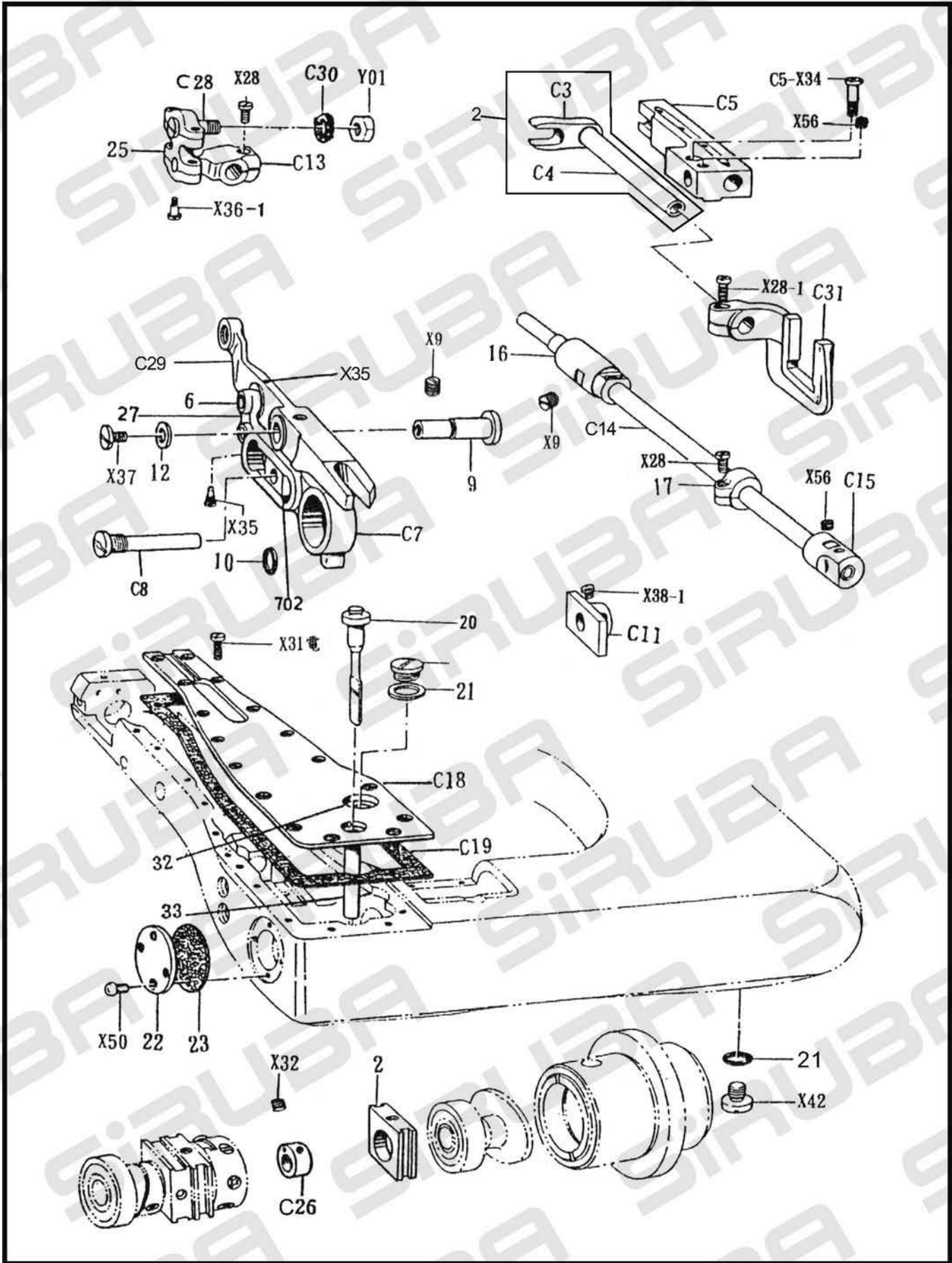

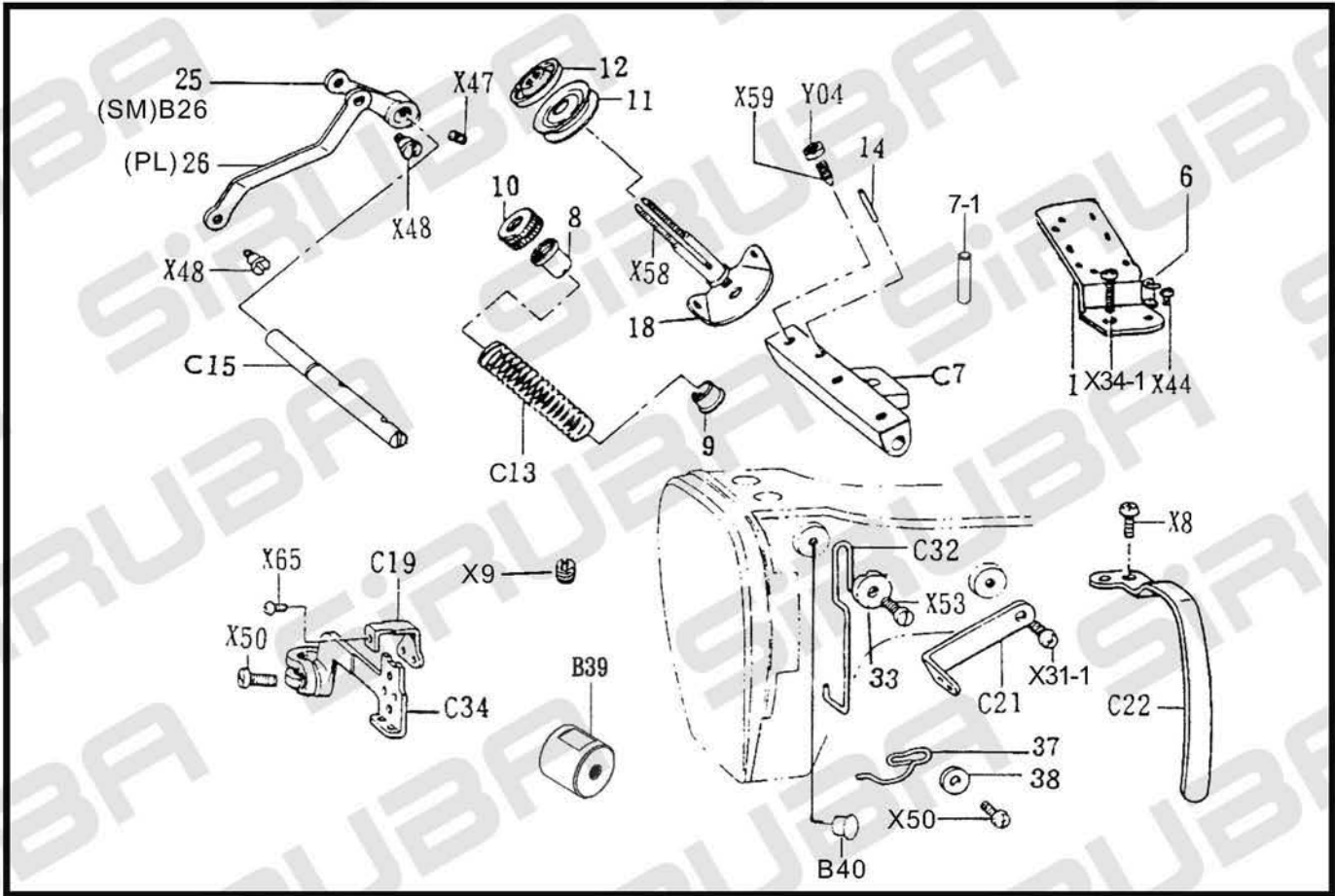

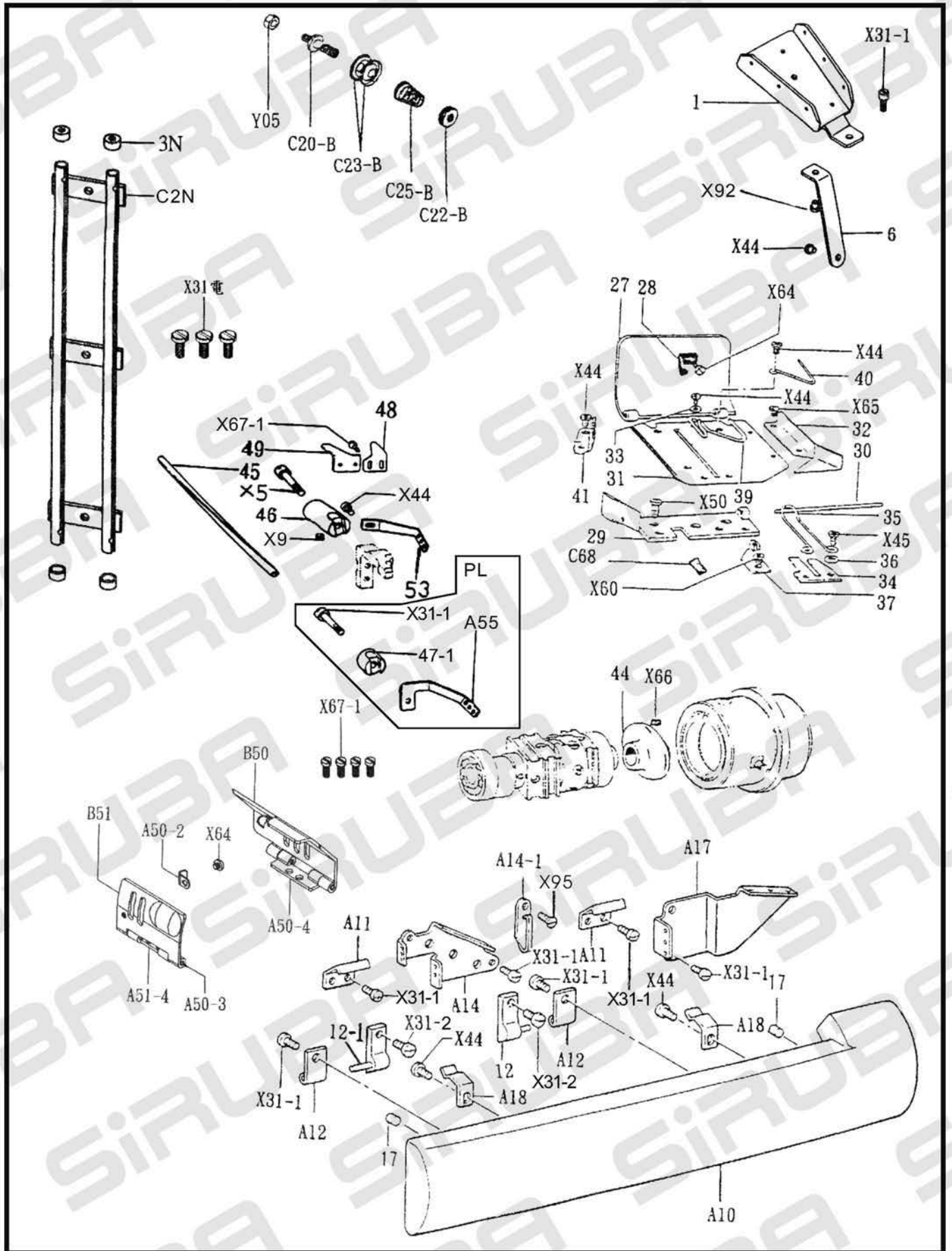

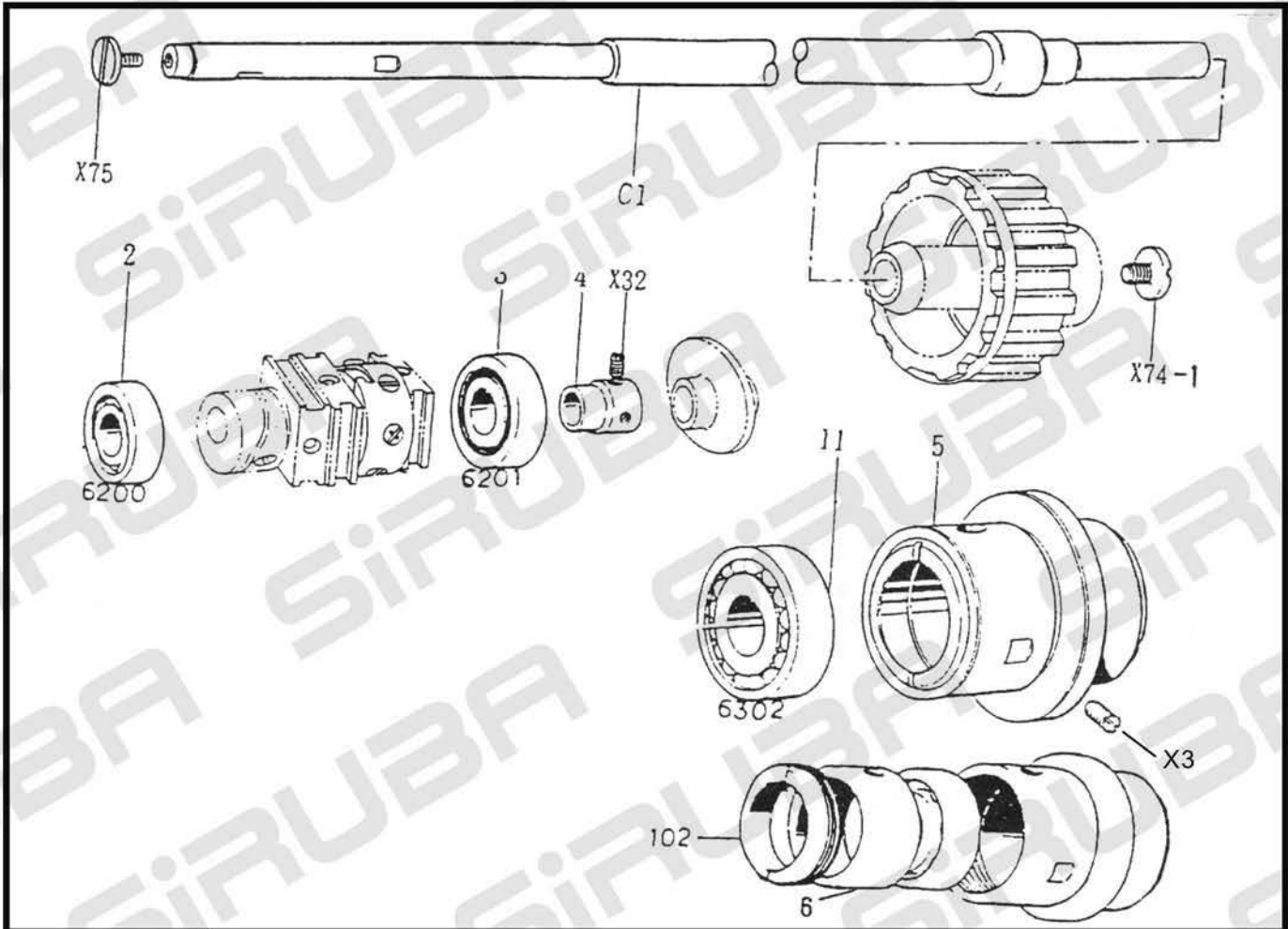

SM1/4

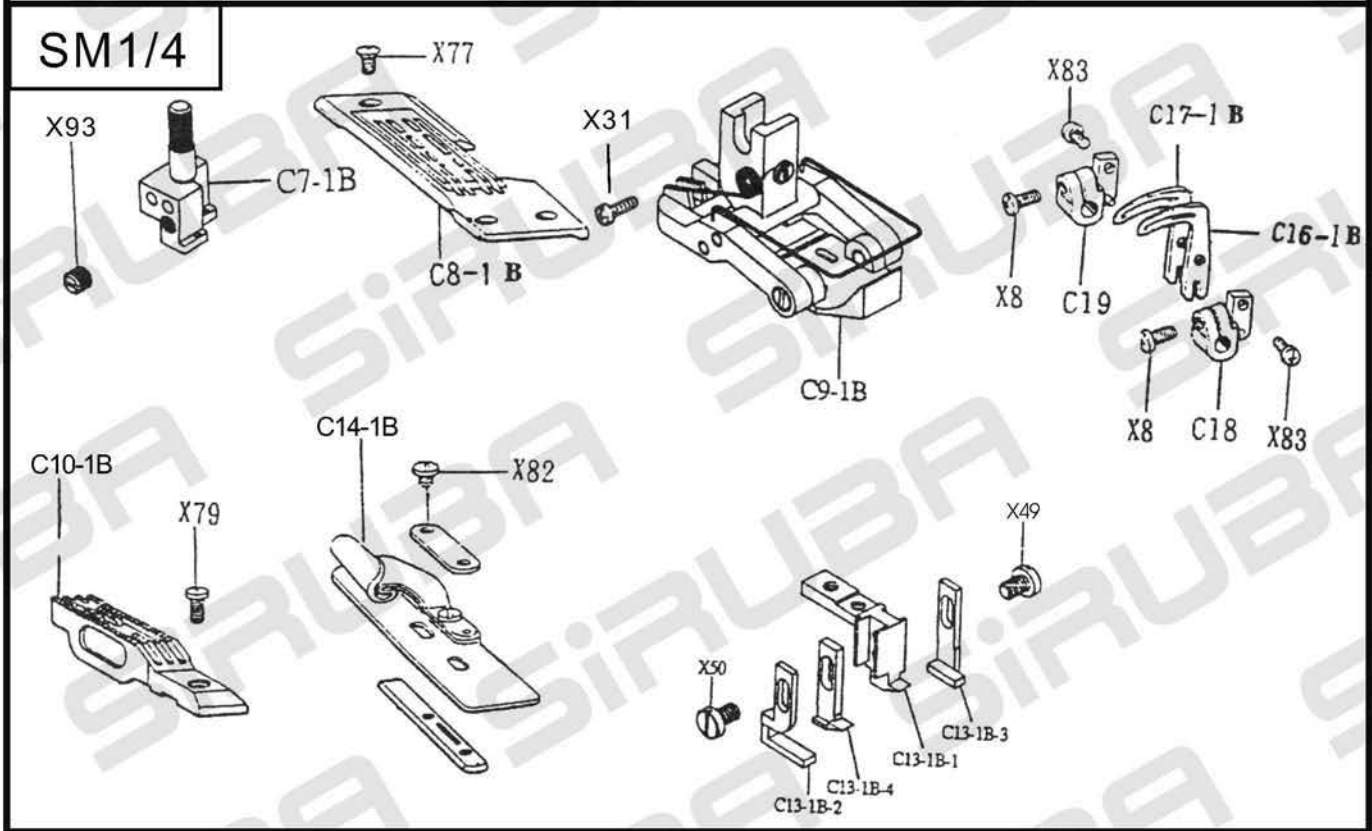

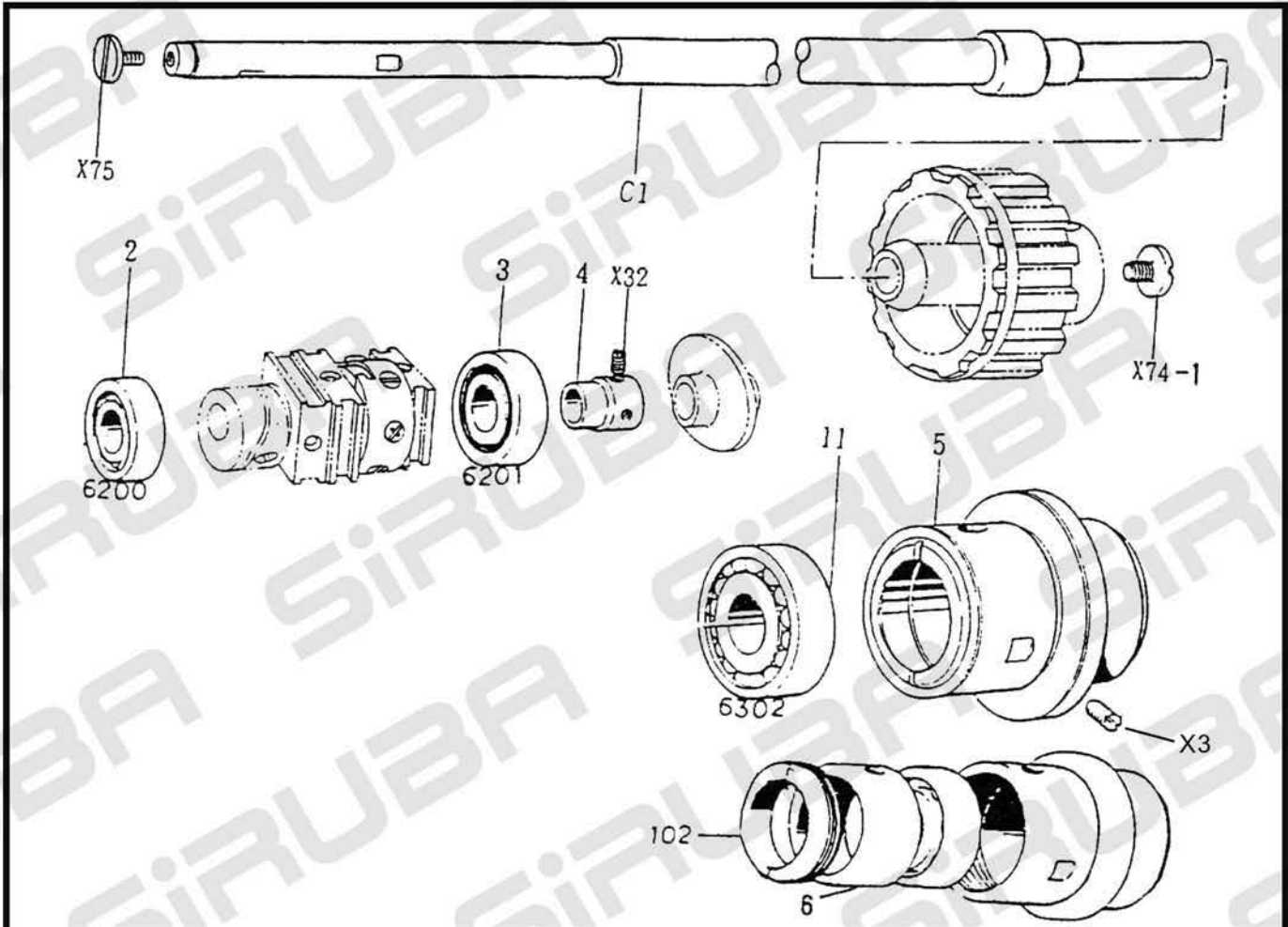

SM3/16

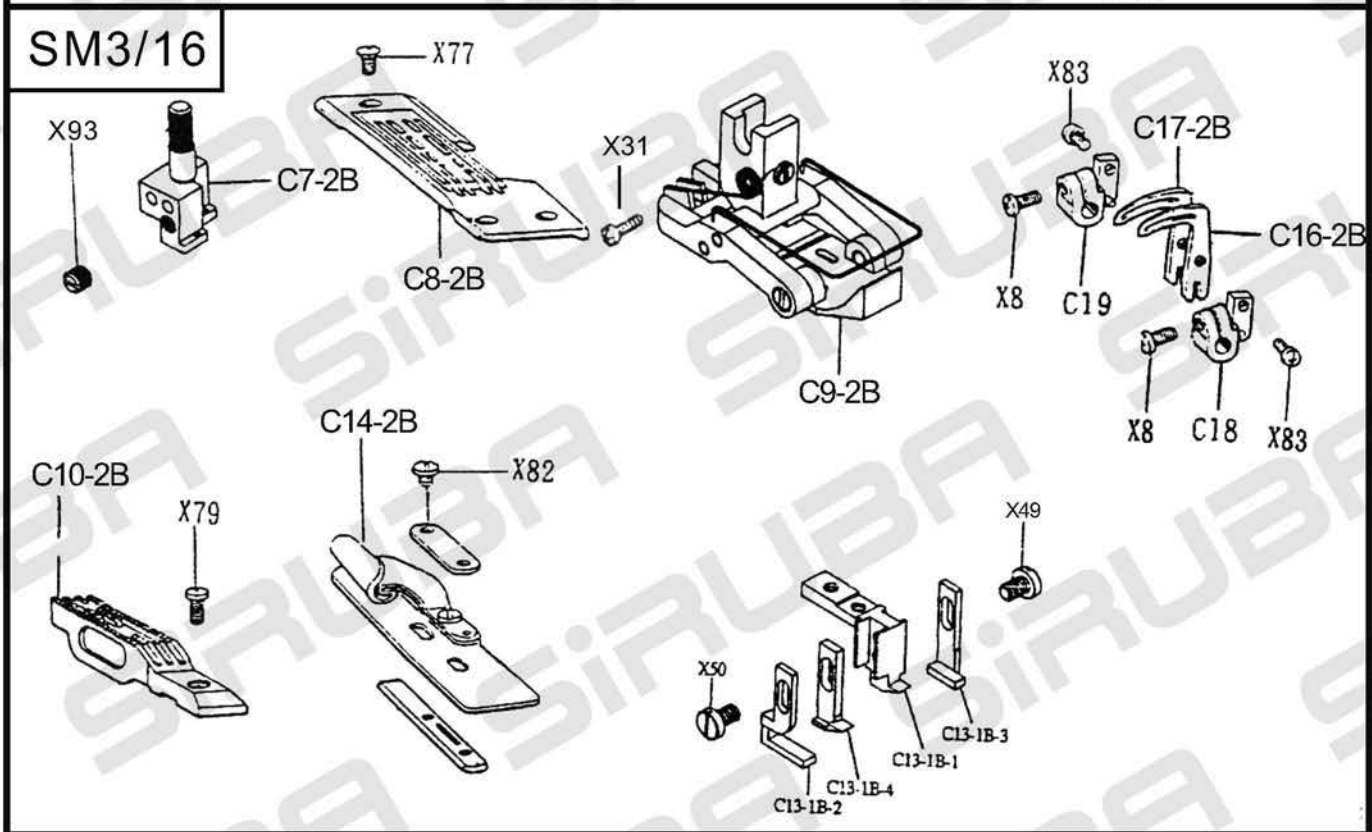

PL

X32



C7-1
C7-2
C7-3



C12

X31



C9-1
C9-2
C9-3

X77

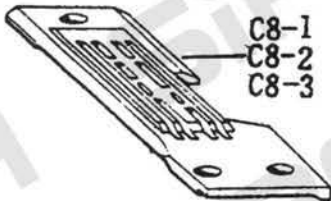

C8-1
C8-2
C8-3

X79



C10-1
C10-2
C10-3



C13

C14-2B
C14-3
C14MH

X82

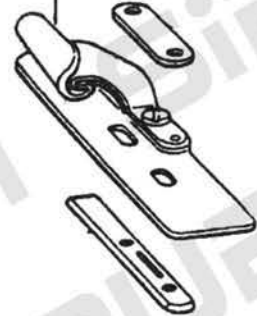

X83



C17-1
C17-2
C17-3



X8



C19

C16-1
C16-2
C16-3



X8



C18



X83

PL

