

SIRUBA®

銀箭牌工業用縫紉機

INDUSTRIAL SEWING MACHINE

F007J/F007JD



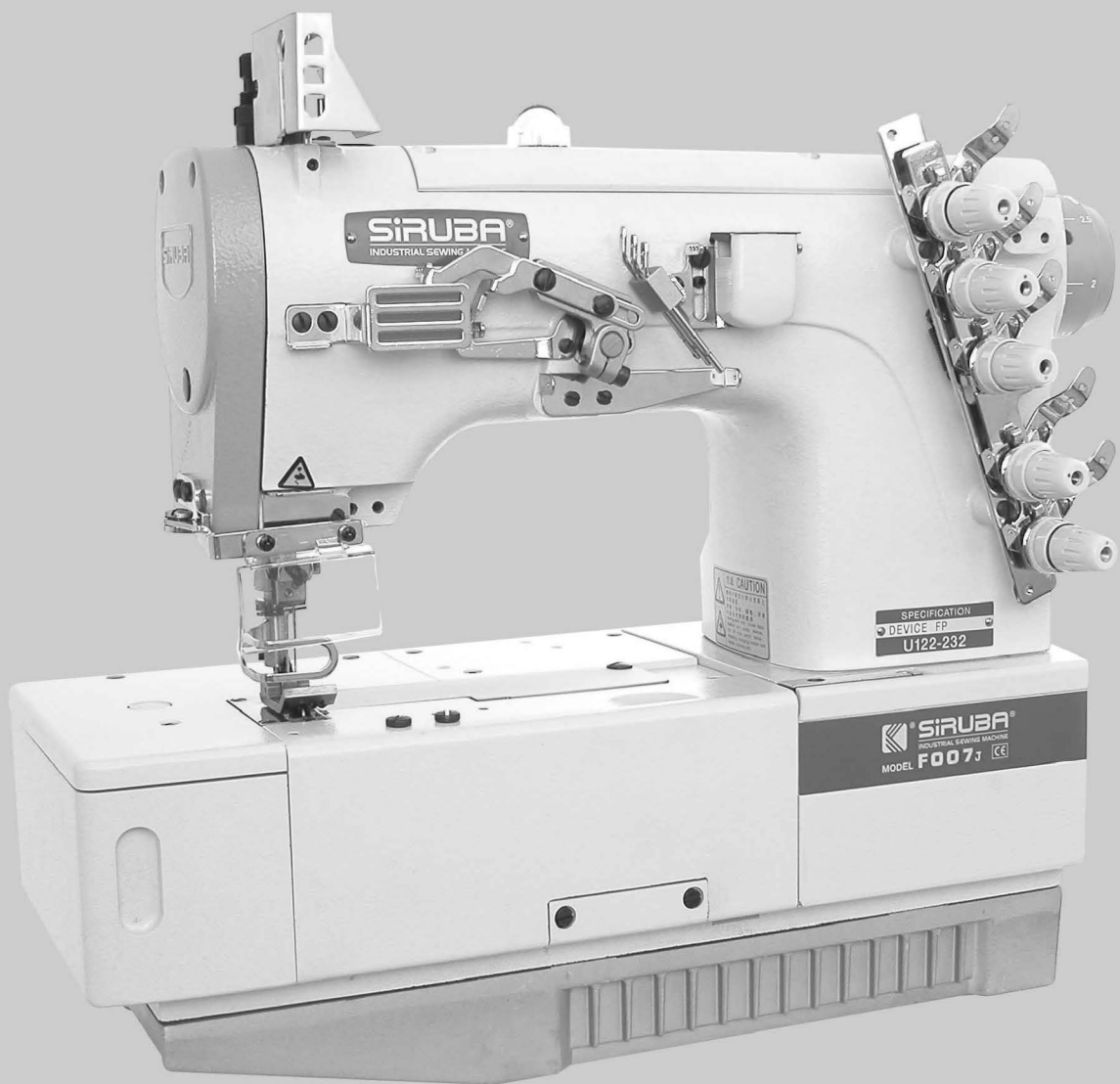





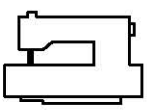

零件圖 PARTS LIST



CE

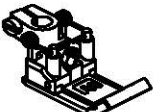





 高林股份有限公司
KAULIN MFG. CO., LTD.

From the library of: Superior Sewing Machine & Supply LLC

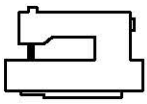

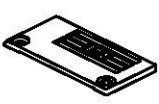
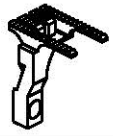
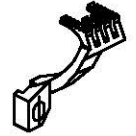
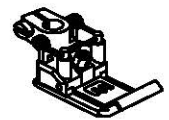





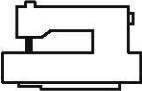

									
MODEL	SUB-CLASS	NEEDLE CLAMP	NEEDLE PLATE	MAIN FEED DOG	DIFF. FEED DOG	PRESSER FOOT	LOOPER	SPREADER	NEEDLE
機 型	規 格	針 座	針 板	主 送 具	差 送 具	押 具	勾 針	上 叉	針 號
F007J-W121	240 248 356 364	M5240 M5248 M5356 M5364	E 1514 E 1515 E 1816 E 1817	D 1206 D 1206 D 1207 D 1207	H1258 H1258 H1259 H1259	P2544 P2545 P2446 P2447	ME28	MH41	UY128GAS #10
F007J-W121 /UTG(UTJ)	240 248 356 364	M5240 M5248 M5356 M5364	E 1514 E 1515 E 1816 E 1817	D 1206 D 1206 D 1207 D 1207	H1258 H1258 H1259 H1259	P2544 P2545 P2446 P2447	ME28	MH41	UY128GAS #10
F007J-U121	240 248 356 364	M5240 M5248 M5356 M5364	E 1514 E 1515 E 1816 E 1817	D 1206 D 1206 D 1207 D 1207	H1258 H1258 H1259 H1259	P2544 P2545 P2446 P2447	ME28	—	UY128GAS #10
F007J-U121 /UTH(UTK)	240 248 356 364	M5240 M5248 M5356 M5364	E 1514 E 1515 E 1816 E 1817	D 1206 D 1206 D 1207 D 1207	H1258 H1258 H1259 H1259	P2544 P2545 P2446 P2447	ME28	—	UY128GAS #10
F007J-W122	240 248 356 364	M5240 M5248 M5356 M5364	E 1524 E 1525 E 1826 E 1827	D 1206 D 1206 D 1207 D 1207	H1258 H1258 H1259 H1259	P2544 P2545 P2446 P2447	ME28	MH41	UY128GAS #10
F007J-W122 /UTG(UTJ)	240 248 356 364	M5240 M5248 M5356 M5364	E 1524 E 1525 E 1826 E 1827	D 1206 D 1206 D 1207 D 1207	H1258 H1258 H1259 H1259	P2544 P2545 P2446 P2447	ME28	MH41	UY128GAS #10
F007J-U122	240 248 356 364	M5240 M5248 M5356 M5364	E 1524 E 1525 E 1826 E 1827	D 1206 D 1206 D 1207 D 1207	H1258 H1258 H1259 H1259	P2544 P2545 P2446 P2447	ME28	—	UY128GAS #10
F007J-U122 /UTH(UTK)	240 248 356 364	M5240 M5248 M5356 M5364	E 1524 E 1525 E 1826 E 1827	D 1206 D 1206 D 1207 D 1207	H1258 H1258 H1259 H1259	P2544 P2545 P2446 P2447	ME28	—	UY128GAS #10

註：P2544/2545 為固定式押具舌,亦可使用活動式押具舌 P2565代替P2544/P2545
P2446/2447 為固定式押具舌,亦可使用活動式押具舌 P2466代替P2446/2447

規格件表 CONVERSION CHART-2

									
MODEL	SUB-CLASS	NEEDLE CLAMP	NEEDLE PLATE	MAIN FEED DOG	DIFF. FEED DOG	PRESSER FOOT	LOOPER	SPREADER	NEEDLE
機 型	規 格	針 座	針 板	主 送 具	差 送 具	押 具	勾 針	上 叉	針 號
F007J-U122 /FP	232	M5232	E 1613	D1206	H1257	P4011	ME28P	—	TV*5 #14
F007J-W 123	240 248 356 364	M5240 M5248 M5356 M5364	E 1534 E 1535 E 1836 E 1837	D1206 D1206 D1207 D1207	H1258 H1258 H1259 H1259	P2544 P2545 P2446 P2447	ME28	MH41	UY128GAS #10
F007J-W 123 /UTG(UTJ)	240 248 356 364	M5240 M5248 M5356 M5364	E 1534 E 1535 E 1836 E 1837	D1206 D1206 D1207 D1207	H1258 H1258 H1259 H1259	P2544 P2545 P2446 P2447	ME28	MH41	UY128GAS #10
F007J-W162	356 364	M5356 M5364	E 1846 E 1847	D1207 D1207	H1259 H1259	P2446 P2447	ME28A	MH41	TV*5 #14~16
F007J-U162	356 364	M5356 M5364	E 1846 E 1847	D1207 D1207	H1259 H1259	P2446 P2447	ME28A	—	TV*5 #14~16
F007J-W162 UTG(UTJ)	356 364	M5356 M5364	E 1846 E 1847	D1207 D1207	H1259 H1259	P2446 P2447	ME28A	MH41	TV*5 #14~16
F007J-U 162 /UTH(UTK)	356 364	M5356 M5364	E 1846 E 1847	D1207 D1207	H1259 H1259	P2446 P2447	ME28A	—	TV*5 #14~16
F007J-W222 /FQ	232 240 248 356 364	M5232 M5240 M5248 M5356 M5364	E 3023 E 3024 E 3025 E 3326 E 3327	D1215 D1215 D1215 D1216 D1216	H1261 H1261 H1261 H1262 H1262	P1813 P1814 P1815 P2116 P2117	ME28	MH41	UY128GAS #10
F007J-W222 /UTG(UTJ)/FQ	240 248 356 364	M5240 M5248 M5356 M5364	E 3024 E 3025 E 3326 E 3327	D1215 D1215 D1216 D1216	H1261 H1261 H1262 H1262	P1814 P1815 P2116 P2117	ME28	MH41	UY128GAS #10
F007J-U 222 /UTH(UTK)/FQ	240 248 356 364	M5240 M5248 M5356 M5364	E 3024 E 3025 E 3326 E 3327	D1215 D1215 D1216 D1216	H1261 H1261 H1262 H1262	P1814 P1815 P2116 P2117	ME28	MH41	UY128GAS #10

註：P2544/2545 為固定式押具舌,亦可使用活動式押具舌 P2565代替P2544/P2545
P2446/2447 為固定式押具舌,亦可使用活動式押具舌 P2466代替P2446/2447

									
MODEL	SUB-CLASS	NEEDLE CLAMP	NEEDLE PLATE	MAIN FEED DOG	DIFF. FEED DOG	PRESSER FOOT	LOOPER	SPREADER	NEEDLE
機 型	規 格	針 座	針 板	主 送 具	差 送 具	押 具	勾 針	上 叉	針 號
F007J-W222 /FQ/FEC(FAC)	240 248 356 364	M5240 M5248 M5356 M5364	E 3024 E 3025 E 3326 E 3327	D 1215 D 1215 D 1216 D 1216	H 1261 H 1261 H 1262 H 1262	P1814 P 1815 P2116 P2117	ME28	MH41	UY128GAS #10
F007J-U222 /FQ	240 248 356 364	M5240 M5248 M5356 M5364	E 3024 E 3025 E 3326 E 3327	D 1215 D 1215 D 1216 D 1216	H 1261 H 1261 H 1262 H 1262	P2314 P 2315 P2616 P2617	ME28	—	UY128GAS #10
F007J-W222A FQ/FEC(FAC)	240 248 356 364	M5240 M5248 M5356 M5364	E 3124 E 3125 E 3426 E 3427	D 1315 D 1315 D 1316 D 1316	H 1261 H 1261 H 1262 H 1262	P1914 P 1915 P2216 P2217	ME28	MH41	UY128GAS #10
F007J-W222 /FFD(FFP)	240 248 356 364	M5240 M5248 M5356 M5364	E 3024 E 3025 E 3326 E 3327	D 1215 D 1215 D 1216 D 1216	H 1261 H 1261 H 1262 H 1262	P1814 P 1815 P2116 P2117	ME28	MH41	UY128GAS #10
F007J-U222 /FFD(FFP)	240 248 356 364	M5240 M5248 M5356 M5364	E 3024 E 3025 E 3326 E 3327	D 1215 D 1215 D 1216 D 1216	H 1261 H 1261 H 1262 H 1262	P2314 P 2315 P2616 P2617	ME28	—	UY128GAS #10
F007J-W222 /FSM	240-4 248-4 364-4	M5240P M5248P M5364P	E 3724 E 3725 E 3727	D 1516	H 1262 H 1262 H 1262	P2714 P 2715 P2717	ME28	MH41	UY128GAS #10
F007J-W322 /FDC	356 364	M5356 M5364	E 4826 E 4827	D 1207 D 1207	H 1359 H 1359	P2446 P 2447	ME28	MH41	UY128GAS #10
F007J-W322 /UTJ(UTJ)/FDC	356 364	M5356 M5364	E 4826 E 4827	D 1207 D 1207	H 1359 H 1359	P2446 P 2447	ME28	MH41	UY128GAS #10
F007J-U322 /FDC	356 364	M5356 M5364	E 4826 E 4827	D 1207 D 1207	H 1359 H 1359	P2446 P 2447	ME28	—	UY128GAS #10

W222A-FAC(FEC) 短切刀

W222-FAC(FEC) 長切刀







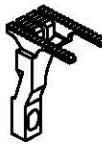

註：P2544/2545 為固定式押具舌，亦可使用活動式押具舌 P2565 代替 P2544/P2545

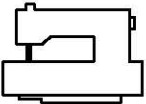
P2446/2447 為固定式押具舌，亦可使用活動式押具舌 P2466 代替 P2446/2447

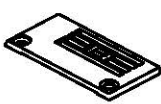
規格件表 CONVERSION CHART-4

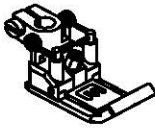







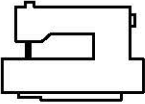

									
MODEL	SUB-CLASS	NEEDLE CLAMP	NEEDLE PLATE	MAIN FEED DOG	DIFF. FEED DOG	PRESSER FOOT	LOOPER	SPREADER	NEEDLE
機 型	規 格	針 座	針 板	主 送 具	差 送 具	押 具	勾 針	上 叉	針 號
F007J-U322 /UTH(UTK)/FDC	356 364	M5356 M5364	E 4826 E 4827	D 1207 D 1207	H 1359 H 1359	P 2446 P 2447	ME28	—	UY128GAS #10
F007J-W322 /FDE	356 364	M5356 M5364	E 4836M E 4837M	D 1207 D 1207	H 1459 H 1459	P 2446 P 2447	ME28	MH41	UY128GAS #10
F007J-W322 /UTG(UTJ)/FDE	356 364	M5356 M5364	E 4836M E 4837M	D 1207 D 1207	H 1459 H 1459	P 2446 P 2447	ME28	MH41	UY128GAS #10
F007J-U322 /FDE	356 364	M5356 M5364	E 4836M E 4837M	D 1207 D 1207	H 1459 H 1459	P 2446 P 2447	ME28	—	UY128GAS #10
F007J-U322 /UTH(UTK)/FDE	356 364	M5356 M5364	E 4836M E 4837M	D 1207 D 1207	H 1459 H 1459	P 2446 P 2447	ME28	—	UY128GAS #10
F007J-W522 /FE(FFC)/FR	232 240 248 356 364	M5232 M5240 M5248 M5356 M5364	E 6023 E 6024 E 6025 E 6326 E 6327	D 2221 D 2221 D 2221 D 2222 D 2222	H 2267 H 2267 H 2267 H 2268 H 2268	P 2813 P 2814 P 2815 P 3116 P 3117	ME28	MH41	UY128GAS #10
F007J-U522 /FE(FFC)/FR	240 248 356 364	M5240 M5248 M5356 M5364	E 6024 E 6025 E 6326 E 6327	D 2221 D 2221 D 2222 D 2222	H 2267 H 2267 H 2268 H 2268	P 2814 P 2815 P 3116 P 3117	ME28	—	UY128GAS #10

註： F007J-W/U322A-³⁵⁶/₃₆₄ /FDC 時，該針板與送具改用 F007H-W/U122-³⁵⁶/₃₆₄ 之針板與送具
 註： P2544/2545 為固定式押具舌，亦可使用活動式押具舌 P2565 代替 P2544/P2545
 P2446/2447 為固定式押具舌，亦可使用活動式押具舌 P2466 代替 P2446/2447

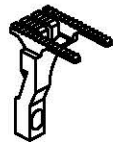
									
MODEL	SUB-CLASS	NEEDLE CLAMP	NEEDLE PLATE	MAIN FEED DOG	DIFF. FEED DOG	PRESSER FOOT	LOOPER	SPREADER	NEEDLE
機 型	規 格	針 座	針 板	主 送 具	差 送 具	押 具	勾 針	上 叉	針 號
F007J-W512 /FE(FFC)	240 248 356 364	M5240 M5248 M5356 M5364	E 1524 E 1525 E 1826 E 1827	D 1206 D 1206 D 1207 D 1207	H 1258 H 1258 H 1259 H 1259	P 2914 P 2915 P 3216 P 3217	ME28	MH41	UY128GAS #10
F007J-U512 /FE(FFC)	240 248 356 364	M5240 M5248 M5356 M5364	E 1524 E 1525 E 1826 E 1827	D 1206 D 1206 D 1207 D 1207	H 1258 H 1258 H 1259 H 1259	P 3414 P 3415 P 3716 P 3717	ME28	—	UY128GAS #10

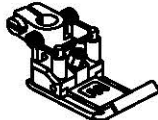
註：F007J-W/U322A-³⁵⁶/₃₆₄ /FDC 時，該針板與送具改用 F007H-W/U122-³⁵⁶/₃₆₄ 之針板與送具
 註：P2544/2545 為固定式押具舌，亦可使用活動式押具舌 P2565 代替 P2544/P2545
 P2446/2447 為固定式押具舌，亦可使用活動式押具舌 P2466 代替 P2446/2447





規格件表 CONVERSION CHART-6

									
MODEL	SUB-CLASS	NEEDLE CLAMP	NEEDLE PLATE	MAIN FEED DOG	DIFF. FEED DOG	PRESSER FOOT	LOOPER	SPREADER	NEEDLE
機 型	規 格	針 座	針 板	主 送 具	差 送 具	押 具	勾 針	上 叉	針 號
F007J- U613 /FBP	256	M5356	E 1836L	D1207	H1259	P4000	ME28	—	TV*5 #14~18
	264	M5364	E 1837L	D1207	H1259	P4001	ME28	—	
F007J- U712	264	M5264	E 5827	D5207	H5259	P4117	ME28	—	TV*3 #11~16
F007J- U712 /FSP	264	M5264	E 5827	D5207	H5259	P5117(減品寬1.0mm用)	FS03/04	—	TV*3 #11~16
F007J- U712A /FSP	264	M5264	E 5827	D5207	H5259	P5118(減品寬1.2mm用)	FS03/04	—	TV*3 #11~16
F007J- U712 /FSR	264	M5264	E 5927	D5307	H5359	P4217	FS03/04	—	TV*7 #12~14
F007J- W722 /FY	388	M4388	E 6828	D6207	H6259	P6117	FS03/04/FY02	FY09	TV*7 #12
F007J- W922 /FW(FWP)	456 460 464	M5456 M5460 M5464	E1828P E1838P E1848P	D1207P	H1259	P2428P P2438P P2448P	FW28	MH41	SM1014B #10 (MY1014B #70 ,SY7256)



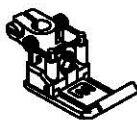

										
MODEL	SUB-CLASS	NEEDLE CLAMP	NEEDLE PLATE	MAIN FEED DOG	DIFF. FEED DOG	PRESSER FOOT	LOOPER	SPREADER	NEEDLE	Motor
機型	規格	針座	針板	主送具	差送具	押具	勾針	上叉	針號	馬達
F007JD-W121	240 248 356 364	M5240 M5248 M5356 M5364	E 1514 E 1515 E 1816 E 1817	D 1206 D 1206 D 1207 D 1207	H 1258 H 1258 H 1259 H 1259	P2544 P2545 P2446 P2447	ME28	MH41	UY128GAS #10	T6401UHM
F007JD-W121 /UTG(UTJ)	240 248 356 364	M5240 M5248 M5356 M5364	E 1514 E 1515 E 1816 E 1817	D 1206 D 1206 D 1207 D 1207	H 1258 H 1258 H 1259 H 1259	P2544 P2545 P2446 P2447	ME28	MH41	UY128GAS #10	
F007JD-U121	240 248 356 364	M5240 M5248 M5356 M5364	E 1514 E 1515 E 1816 E 1817	D 1206 D 1206 D 1207 D 1207	H 1258 H 1258 H 1259 H 1259	P2544 P2545 P2446 P2447	ME28	—	UY128GAS #10	
F007JD-U121 /UTH(UTK)	240 248 356 364	M5240 M5248 M5356 M5364	E 1514 E 1515 E 1816 E 1817	D 1206 D 1206 D 1207 D 1207	H 1258 H 1258 H 1259 H 1259	P2544 P2545 P2446 P2447	ME28	—	UY128GAS #10	
F007JD-W122	240 248 356 364	M5240 M5248 M5356 M5364	E 1524 E 1525 E 1826 E 1827	D 1206 D 1206 D 1207 D 1207	H 1258 H 1258 H 1259 H 1259	P2544 P2545 P2446 P2447	ME28	MH41	UY128GAS #10	
F007JD-W122 /UTG(UTJ)	240 248 356 364	M5240 M5248 M5356 M5364	E 1524 E 1525 E 1826 E 1827	D 1206 D 1206 D 1207 D 1207	H 1258 H 1258 H 1259 H 1259	P2544 P2545 P2446 P2447	ME28	MH41	UY128GAS #10	
F007JD-U122	240 248 356 364	M5240 M5248 M5356 M5364	E 1524 E 1525 E 1826 E 1827	D 1206 D 1206 D 1207 D 1207	H 1258 H 1258 H 1259 H 1259	P2544 P2545 P2446 P2447	ME28	—	UY128GAS #10	
F007JD-U122 /UTH(UTK)	240 248 356 364	M5240 M5248 M5356 M5364	E 1524 E 1525 E 1826 E 1827	D 1206 D 1206 D 1207 D 1207	H 1258 H 1258 H 1259 H 1259	P2544 P2545 P2446 P2447	ME28	—	UY128GAS #10	

註：P2544/2545 為固定式押具舌，亦可使用活動式押具舌 P2565 代替 P2544/P2545
P2446/2447 為固定式押具舌，亦可使用活動式押具舌 P2466 代替 P2446/2447

規格件表 CONVERSION CHART-8

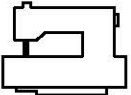
										
MODEL	SUB-CLASS	NEEDLE CLAMP	NEEDLE PLATE	MAIN FEED DOG	DIFF. FEED DOG	PRESSER FOOT	LOOPER	SPREADER	NEEDLE	Motor
機 型	規 格	針 座	針 板	主送具	差送具	押 具	勾 針	上 叉	針 號	馬 達
F007JD-U122 /FP	232	M5232	E 1613	D 1206	H 1257	P 4011	ME28P	—	TV*5 #14	☐ T6401UHM
F007JD-W123	240 248 356 364	M5240 M5248 M5356 M5364	E 1534 E1535 E 1836 E 1837	D 1206 D 1206 D 1207 D 1207	H 1258 H 1258 H 1259 H 1259	P2544 P2545 P2446 P2447	ME28	MH41	UY128GAS #10	
F007JD-W 123 /UTG(UTJ)	240 248 356 364	M5240 M5248 M5356 M5364	E 1534 E1535 E 1836 E 1837	D 1206 D 1206 D 1207 D 1207	H 1258 H 1258 H 1259 H 1259	P2544 P2545 P2446 P2447	ME28	MH41	UY128GAS #10	
F007JD-W162	356 364	M5356 M5364	E 1846 E 1847	D 1207 D 1207	H 1259 H 1259	P2446 P2447	ME28A	MH41	TV*5 #14~16	
F007JD-U162	356 364	M5356 M5364	E 1846 E 1847	D 1207 D 1207	H 1259 H 1259	P2446 P2447	ME28A	—	TV*5 #14~16	
F007JD-W162 UTG(UTJ)	356 364	M5356 M5364	E 1846 E 1847	D 1207 D 1207	H 1259 H 1259	P2446 P2447	ME28A	MH41	TV*5 #14~16	
F007JD-U 162 /UTH(UTK)	356 364	M5356 M5364	E 1846 E 1847	D 1207 D 1207	H 1259 H 1259	P2446 P2447	ME28A	—	TV*5 #14~16	
F007JD-W222 /FQ	240 248 356 364	M5240 M5248 M5356 M5364	E 3024 E3025 E 3326 E 3327	D 1215 D 1215 D 1216 D 1216	H 1261 H 1261 H 1262 H 1262	P1814 P1815 P2116 P2117	ME28	MH41	UY128GAS #10	
F007JD-W222 /UTG(UTJ)/FQ	240 248 356 364	M5240 M5248 M5356 M5364	E 3024 E3025 E 3326 E 3327	D 1215 D 1215 D 1216 D 1216	H 1261 H 1261 H 1262 H 1262	P1814 P1815 P2116 P2117	ME28	MH41	UY128GAS #10	
F007JD-U 222 /UTH(UTK)/FQ	240 248 356 364	M5240 M5248 M5356 M5364	E 3024 E3025 E 3326 E 3327	D 1215 D 1215 D 1216 D 1216	H 1261 H 1261 H 1262 H 1262	P1814 P1815 P2116 P2117	ME28	MH41	UY128GAS #10	

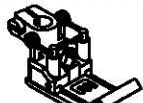
註：P2544/2545 為固定式押具舌，亦可使用活動式押具舌 P2565 代替 P2544/P2545
 P2446/2447 為固定式押具舌，亦可使用活動式押具舌 P2466 代替 P2446/2447

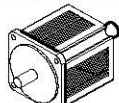
										
MODEL	SUB-CLASS	NEEDLE CLAMP	NEEDLE PLATE	MAIN FEED DOG	DIFF. FEED DOG	PRESSER FOOT	LOOPER	SPREADER	NEEDLE	Motor
機 型	規 格	針 座	針 板	主送具	差送具	押 具	勾 針	上 叉	針 號	馬 達
F007JD-W222 /FQ/FEC(FAC)	240 248 356 364	M5240 M5248 M5356 M5364	E 3024 E3025 E 3326 E 3327	D1215 D1215 D1216 D1216	H1261 H1261 H1262 H1262	P1814 P1815 P2116 P2117	ME28	MH41	UY128GAS #10	T6401UHM
F007JD-U222 /FQ	240 248 356 364	M5240 M5248 M5356 M5364	E 3024 E3025 E 3326 E 3327	D1215 D1215 D1216 D1216	H1261 H1261 H1262 H1262	P2314 P2315 P2616 P2617	ME28	—	UY128GAS #10	
F007JD-W222A FQ/FEC(FAC)	240 248 356 364	M5240 M5248 M5356 M5364	E 3124 E3125 E 3426 E 3427	D1315 D1315 D1316 D1316	H1261 H1261 H1262 H1262	P1914 P1915 P2216 P2217	ME28	MH41	UY128GAS #10	
F007JD-W222 /FFP	240 248 356 364	M5240 M5248 M5356 M5364	E 3024 E3025 E 3326 E 3327	D1215 D1215 D1216 D1216	H1261 H1261 H1262 H1262	P1814 P1815 P2116 P2117	ME28	MH41	UY128GAS #10	
F007JD-U222 /FFP	240 248 356 364	M5240 M5248 M5356 M5364	E 3024 E3025 E 3326 E 3327	D1215 D1215 D1216 D1216	H1261 H1261 H1262 H1262	P2314 P2315 P2616 P2617	ME28	—	UY128GAS #10	
F007JD-W322 /FDC	356 364	M5356 M5364	E 4826 E 4827	D1207 D1207	H1359 H1359	P2446 P2447	ME28	MH41	UY128GAS #10	
F007JD-W322 /UTG(UTJ)/FDC	356 364	M5356 M5364	E 4826 E 4827	D1207 D1207	H1359 H1359	P2446 P2447	ME28	MH41	UY128GAS #10	
F007JD-U322 /FDC	356 364	M5356 M5364	E 4826 E 4827	D1207 D1207	H1359 H1359	P2446 P2447	ME28	—	UY128GAS #10	
F007JD-U322 /UTH(UTK)/FDC	356 364	M5356 M5364	E 4826 E 4827	D1207 D1207	H1359 H1359	P2446 P2447	ME28	—	UY128GAS #10	







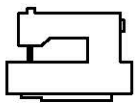

W222A-FAC(FEC) 短切刀

W222-FAC(FEC) 長切刀

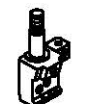
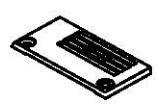
註：P2544/2545 為固定式押具舌，亦可使用活動式押具舌 P2565 代替 P2544/P2545

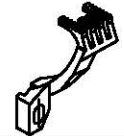
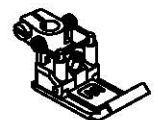



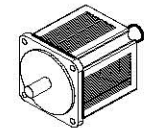



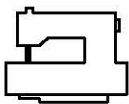

P2446/2447 為固定式押具舌，亦可使用活動式押具舌 P2466 代替 P2446/2447

規格件表 CONVERSION CHART-10

										
MODEL	SUB-CLASS	NEEDLE CLAMP	NEEDLE PLATE	MAIN FEED DOG	DIFF. FEED DOG	PRESSER FOOT	LOOPER	SPREADER	NEEDLE	Motor
機型	規格	針座	針板	主送具	差送具	押具	勾針	上叉	針號	馬達
F007JD-W322 /FDE	356 364	M5356 M5364	E 4836M E 4837M	D1207 D1207	H1459 H1459	P2446 P2447	ME28	MH41	UY128GAS #10	☐ T6401UHM
F007JD-W322 /UTG(UTJ)/FDE	356 364	M5356 M5364	E 4836M E 4837M	D1207 D1207	H1459 H1459	P2446 P2447	ME28	MH41	UY128GAS #10	
F007JD-U322 /FDE	356 364	M5356 M5364	E 4836M E 4837M	D1207 D1207	H1459 H1459	P2446 P2447	ME28	—	UY128GAS #10	
F007JD-U322 /UTH(UTK)/FDE	356 364	M5356 M5364	E 4836M E 4837M	D1207 D1207	H1459 H1459	P2446 P2447	ME28	—	UY128GAS #10	
F007JD-W522 /FE/FR	240 248 356 364	M5240 M5248 M5356 M5364	E 6024 E 6025 E 6326 E 6327	D 2221 D 2221 D 2222 D 2222	H 2267 H 2267 H 2268 H 2268	P2814 P2815 P3116 P3117	ME28	MH41	UY128GAS #10	
F007JD-U522 /FE/FR	240 248 356 364	M5240 M5248 M5356 M5364	E 6024 E 6025 E 6326 E 6327	D 2221 D 2221 D 2222 D 2222	H 2267 H 2267 H 2268 H 2268	P2814 P2815 P3116 P3117	ME28	—	UY128GAS #10	
F007JD-W512 /FE	240 248 356 364	M5240 M5248 M5356 M5364	E 1524 E 1525 E 1826 E 1827	D 1206 D 1206 D 1207 D 1207	H 1258 H 1258 H 1259 H 1259	P 2914 P 2915 P 3216 P 3217	ME28	MH41	UY128GAS #10	
F007JD-U512 /FE	240 248 356 364	M5240 M5248 M5356 M5364	E 1524 E 1525 E 1826 E 1827	D 1206 D 1206 D 1207 D 1207	H 1258 H 1258 H 1259 H 1259	P 3414 P 3415 P 3716 P 3717	ME28	—	UY128GAS #10	

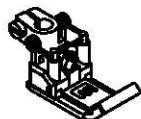
註： F007JD-W/U322A-³⁵⁶/₃₆₄ /FDC 時，該針板與送具改用 F007H-W/U122-³⁵⁶/₃₆₄ 之針板與送具

註： P2544/2545 為固定式押具舌，亦可使用活動式押具舌 P2565 代替 P2544/P2545
 P2446/2447 為固定式押具舌，亦可使用活動式押具舌 P2466 代替 P2446/2447

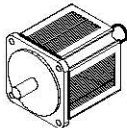
										
MODEL	SUB-CLASS	NEEDLE CLAMP	NEEDLE PLATE	MAIN FEED DOG	DIFF. FEED DOG	PRESSER FOOT	LOOPER	SPREADER	NEEDLE	Motor
機型	規格	針座	針板	主送具	差送具	押具	勾針	上叉	針號	馬達
F007JD-U613 /FBP	256	M5356	E 1836L	D1207	H 1259	P4000	ME28	—	TV*5 #14~18	T6401UHM
	264	M5364	E 1837L	D1207	H 1259	P4001	ME28	—		
F007JD-U712	264	M5264	E 5827	D 5207	H 5259	P4117	ME28	—	TV*3 #11~16	
F007JD-U712 /FSP	264	M5264	E 5827	D 5207	H 5259	P5117(減速比1.0mm用)	FS03/04	—	TV*3 #11~16	
F007JD-U712A /FSP	264	M5264	E 5827	D 5207	H 5259	P5118(減速比1.2mm用)	FS03/04	—	TV*3 #11~16	
F007JD-U712 /FSR	264	M5264	E 5927	D 5307	H 5359	P4217	FS03/04	—	TV*7 #12~14	
F007JD-W722 /FY	388	M4388	E 6828	D 6207	H 6259	P6117	FS03/04/FY02	FY09	TV*7 #12	
F007JD-W922 /FW(FWP)	456 460 464	M5456 M5460 M5464	E1828P E1838P E1848P	D1207P	H1259	P2428P P2438P P2448P	FW28	MH41	SM1014B #10 (MY1014B #70 ,SY7256)	

F007J: 為一般馬達,外置式機種 ; F007JD: 為加裝直驅伺服馬達機種

規格件表 CONVERSION CHART-12

										
MODEL	SUB-CLASS	NEEDLE CLAMP	NEEDLE PLATE	MAIN FEED DOG	DIFF. FEED DOG	PRESSER FOOT	LOOPER	SPREADER	NEEDLE	Motor
機 型	規 格	針 座	針 板	主送具	差送具	押 具	勾 針	上 叉	針 號	馬 達
F007JD-W121 /K	240 248 356 364	M5240 M5248 M5356 M5364	E 1514 E 1515 E 1816 E 1817	D 1206 D 1206 D 1207 D 1207	H 1258 H 1258 H 1259 H 1259	P2544 P2545 P2446 P2447	ME28	MH41	UY128GAS #10	□ T6400UPM
F007JD-W121 /UTG(UTJ)/K	240 248 356 364	M5240 M5248 M5356 M5364	E 1514 E 1515 E 1816 E 1817	D 1206 D 1206 D 1207 D 1207	H 1258 H 1258 H 1259 H 1259	P2544 P2545 P2446 P2447	ME28	MH41	UY128GAS #10	
F007JD-U121 /K	240 248 356 364	M5240 M5248 M5356 M5364	E 1514 E 1515 E 1816 E 1817	D 1206 D 1206 D 1207 D 1207	H 1258 H 1258 H 1259 H 1259	P2544 P2545 P2446 P2447	ME28	—	UY128GAS #10	
F007JD-U121 /UTH(UTK)/K	240 248 356 364	M5240 M5248 M5356 M5364	E 1514 E 1515 E 1816 E 1817	D 1206 D 1206 D 1207 D 1207	H 1258 H 1258 H 1259 H 1259	P2544 P2545 P2446 P2447	ME28	—	UY128GAS #10	
F007JD-W122 /K	240 248 356 364	M5240 M5248 M5356 M5364	E 1524 E 1525 E 1826 E 1827	D 1206 D 1206 D 1207 D 1207	H 1258 H 1258 H 1259 H 1259	P2544 P2545 P2446 P2447	ME28	MH41	UY128GAS #10	
F007JD-W122 /UTG(UTJ)/K	240 248 356 364	M5240 M5248 M5356 M5364	E 1524 E 1525 E 1826 E 1827	D 1206 D 1206 D 1207 D 1207	H 1258 H 1258 H 1259 H 1259	P2544 P2545 P2446 P2447	ME28	MH41	UY128GAS #10	
F007JD-U122 /K	240 248 356 364	M5240 M5248 M5356 M5364	E 1524 E 1525 E 1826 E 1827	D 1206 D 1206 D 1207 D 1207	H 1258 H 1258 H 1259 H 1259	P2544 P2545 P2446 P2447	ME28	—	UY128GAS #10	
F007JD-U122 /UTH(UTK)/K	240 248 356 364	M5240 M5248 M5356 M5364	E 1524 E 1525 E 1826 E 1827	D 1206 D 1206 D 1207 D 1207	H 1258 H 1258 H 1259 H 1259	P2544 P2545 P2446 P2447	ME28	—	UY128GAS #10	

註：P2544/2545 為固定式押具舌，亦可使用活動式押具舌 P2565 代替 P2544/P2545
 P2446/2447 為固定式押具舌，亦可使用活動式押具舌 P2466 代替 P2446/2447

										
MODEL	SUB-CLASS	NEEDLE CLAMP	NEEDLE PLATE	MAIN FEED DOG	DIFF. FEED DOG	PRESSER FOOT	LOOPER	SPREADER	NEEDLE	Motor
機型	規格	針座	針板	主送具	差送具	押具	勾針	上叉	針號	馬達
F007JD-U122 /FP/K	232	M5232	E 1613	D1206	H1257	P4011	ME28P	—	TV*5 #14	□ T6400UPM
F007JD-W123 /K	240 248 356 364	M5240 M5248 M5356 M5364	E 1534 E1535 E 1836 E 1837	D1206 D1206 D1207 D1207	H1258 H1258 H1259 H1259	P2544 P2545 P2446 P2447	ME28	MH41	UY128GAS #10	
F007JD-W 123 /UTG(UTJ)/K	240 248 356 364	M5240 M5248 M5356 M5364	E 1534 E1535 E 1836 E 1837	D1206 D1206 D1207 D1207	H1258 H1258 H1259 H1259	P2544 P2545 P2446 P2447	ME28	MH41	UY128GAS #10	
F007JD-W162 /K	356 364	M5356 M5364	E 1846 E 1847	D1207 D1207	H1259 H1259	P2446 P2447	ME28A	MH41	TV*5 #14~16	
F007JD-U162 /K	356 364	M5356 M5364	E 1846 E 1847	D1207 D1207	H1259 H1259	P2446 P2447	ME28A	—	TV*5 #14~16	
F007JD-W162 /UTG(UTJ)/K	356 364	M5356 M5364	E 1846 E 1847	D1207 D1207	H1259 H1259	P2446 P2447	ME28A	MH41	TV*5 #14~16	
F007JD-U 162 /UTH(UTK)/K	356 364	M5356 M5364	E 1846 E 1847	D1207 D1207	H1259 H1259	P2446 P2447	ME28A	—	TV*5 #14~16	
F007JD-W222 /FQ/K	240 248 356 364	M5240 M5248 M5356 M5364	E 3024 E3025 E 3326 E 3327	D1215 D1215 D1216 D1216	H1261 H1261 H1262 H1262	P1814 P1815 P2116 P2117	ME28	MH41	UY128GAS #10	
F007JD-W222 /UTG(UTJ)/FQ/K	240 248 356 364	M5240 M5248 M5356 M5364	E 3024 E3025 E 3326 E 3327	D1215 D1215 D1216 D1216	H1261 H1261 H1262 H1262	P1814 P1815 P2116 P2117	ME28	MH41	UY128GAS #10	
F007JD-U 222 /UTH(UTK)/FQ/K	240 248 356 364	M5240 M5248 M5356 M5364	E 3024 E3025 E 3326 E 3327	D1215 D1215 D1216 D1216	H1261 H1261 H1262 H1262	P1814 P1815 P2116 P2117	ME28	MH41	UY128GAS #10	

註：P2544/2545 為固定式押具舌，亦可使用活瓣式押具舌 P2565 代替 P2544/P2545
P2446/2447 為固定式押具舌，亦可使用活瓣式押具舌 P2466 代替 P2446/2447

規格件表 CONVERSION CHART-14









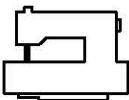

										
MODEL	SUB-CLASS	NEEDLE CLAMP	NEEDLE PLATE	MAIN FEED DOG	DIFF. FEED DOG	PRESSER FOOT	LOOPER	SPREADER	NEEDLE	Motor
機 型	規 格	針 座	針 板	主送具	差送具	押 具	勾 針	上 叉	針 號	馬 達
F007JD-W222 /FQ/FEC(FAC)/K	240 248 356 364	M5240 M5248 M5356 M5364	E 3024 E3025 E 3326 E 3327	D1215 D1215 D1216 D1216	H1261 H1261 H1262 H1262	P1814 P1815 P2116 P2117	ME28	MH41	UY128GAS #10	□ T6400UPM
F007JD-U222 /FQ/K	240 248 356 364	M5240 M5248 M5356 M5364	E 3024 E3025 E 3326 E 3327	D1215 D1215 D1216 D1216	H1261 H1261 H1262 H1262	P2314 P2315 P2616 P2617	ME28	—	UY128GAS #10	
F007JD-W222A /FQ/FEC(FAC)/K	240 248 356 364	M5240 M5248 M5356 M5364	E 3124 E3125 E 3426 E 3427	D1315 D1315 D1316 D1316	H1261 H1261 H1262 H1262	P1914 P1915 P2216 P2217	ME28	MH41	UY128GAS #10	
F007JD-W222 /FFP/K	240 248 356 364	M5240 M5248 M5356 M5364	E 3024 E3025 E 3326 E 3327	D1215 D1215 D1216 D1216	H1261 H1261 H1262 H1262	P1814 P1815 P2116 P2117	ME28	MH41	UY128GAS #10	
F007JD-U222 /FFP/K	240 248 356 364	M5240 M5248 M5356 M5364	E 3024 E3025 E 3326 E 3327	D1215 D1215 D1216 D1216	H1261 H1261 H1262 H1262	P2314 P2315 P2616 P2617	ME28	—	UY128GAS #10	
F007JD-W322 /FDC/K	356 364	M5356 M5364	E 4826 E 4827	D1207 D1207	H1359 H1359	P2446 P2447	ME28	MH41	UY128GAS #10	
F007JD-W322 /UTG(UTJ)/FDC/K	356 364	M5356 M5364	E 4826 E 4827	D1207 D1207	H1359 H1359	P2446 P2447	ME28	MH41	UY128GAS #10	
F007JD-U322 /FDC/K	356 364	M5356 M5364	E 4826 E 4827	D1207 D1207	H1359 H1359	P2446 P2447	ME28	—	UY128GAS #10	
F007JD-U322 /UTH(UTK)/FDC/K	356 364	M5356 M5364	E 4826 E 4827	D1207 D1207	H1359 H1359	P2446 P2447	ME28	—	UY128GAS #10	

W222A-FAC(FEC) 短切刀

W222-FAC(FEC) 長切刀

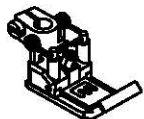
註：P2544/2545 為固定式押具舌，亦可使用活動式押具舌 P2565 代替 P2544/P2545



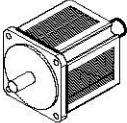





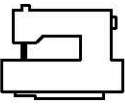

P2446/2447 為固定式押具舌，亦可使用活動式押具舌 P2466 代替 P2446/2447

										
MODEL	SUB-CLASS	NEEDLE CLAMP	NEEDLE PLATE	MAIN FEED DOG	DIFF. FEED DOG	PRESSER FOOT	LOOPER	SPREADER	NEEDLE	Motor
機 型	規 格	針 座	針 板	主 送 具	差 送 具	押 具	勾 針	上 叉	針 號	馬 達
F007JD-W322 /FDE/K	356 364	M5356 M5364	E 4836M E 4837M	D1207 D1207	H1459 H1459	P2446 P2447	ME28	MH41	UY128GAS #10	□ T6400UPM
F007JD-W322 /UTG(UTJ)/FDE/K	356 364	M5356 M5364	E 4836M E 4837M	D1207 D1207	H1459 H1459	P2446 P2447	ME28	MH41	UY128GAS #10	
F007JD-U322 /FDE/K	356 364	M5356 M5364	E 4836M E 4837M	D1207 D1207	H1459 H1459	P2446 P2447	ME28	—	UY128GAS #10	
F007JD-U322 /UTH(UTK)/FDE/K	356 364	M5356 M5364	E 4836M E 4837M	D1207 D1207	H1459 H1459	P2446 P2447	ME28	—	UY128GAS #10	
F007JD-W522 /FE/FR/K	240 248 356 364	M5240 M5248 M5356 M5364	E 6024 E 6025 E 6326 E 6327	D2221 D2221 D2222 D2222	H2267 H2267 H2268 H2268	P2814 P2815 P3116 P3117	ME28	MH41	UY128GAS #10	
F007JD-U522 /FE/FR/K	240 248 356 364	M5240 M5248 M5356 M5364	E 6024 E 6025 E 6326 E 6327	D2221 D2221 D2222 D2222	H2267 H2267 H2268 H2268	P2814 P2815 P3116 P3117	ME28	—	UY128GAS #10	
F007JD-W512 /FE/K	240 248 356 364	M5240 M5248 M5356 M5364	E 1524 E 1525 E 1826 E 1827	D1206 D1206 D1207 D1207	H1258 H1258 H1259 H1259	P2914 P2915 P3216 P3217	ME28	MH41	UY128GAS #10	
F007JD-U512 /FE/K	240 248 356 364	M5240 M5248 M5356 M5364	E 1524 E 1525 E 1826 E 1827	D1206 D1206 D1207 D1207	H1258 H1258 H1259 H1259	P3414 P3415 P3716 P3717	ME28	—	UY128GAS #10	

註：F007JD-W/U322A-³⁵⁶/₃₆₄ /FDC 時，該針板與送具改用 F007H-W/U122-³⁵⁶/₃₆₄ 之針板與送具

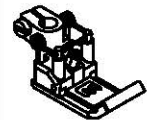
註：P2544/2545 為固定式押具舌，亦可使用活動式押具舌 P2565 代替 P2544/P2545
P2446/2447 為固定式押具舌，亦可使用活動式押具舌 P2466 代替 P2446/2447

規格件表 CONVERSION CHART-16

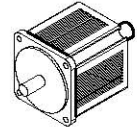
										
MODEL	SUB-CLASS	NEEDLE CLAMP	NEEDLE PLATE	MAIN FEED DOG	DIFF. FEED DOG	PRESSER FOOT	LOOPER	SPREADER	NEEDLE	Motor
機 型	規 格	針 座	針 板	主 送 具	差 送 具	押 具	勾 針	上 叉	針 號	馬 達
F007JD-U613 /FBP/K	256	M5356	E 1836L	D1207	H1259	P4000	ME28	—	TV*5 #14~18	T6400UPM
	264	M5364	E 1837L	D1207	H1259	P4001	ME28	—		
F007JD-U712 /K	264	M5264	E 5827	D5207	H5259	P4117	ME28	—	TV*3 #11~16	
F007JD-U712 /FSP/K	264	M5264	E 5827	D5207	H5259	P5117(減品寬1.0mm用)	FS03/04	—	TV*3 #11~16	
F007JD-U712A /FSP/K	264	M5264	E 5827	D5207	H5259	P5118(減品寬1.2mm用)	FS03/04	—	TV*3 #11~16	
F007JD-U712 /FSR/K	264	M5264	E 5927	D5307	H5359	P4217	FS03/04	—	TV*7 #12~14	
F007JD-W722 /FY/K	388	M4388	E 6828	D6207	H6259	P6117	FS03/04/FY02	FY09	TV*7 #12	
F007JD-W922 /FW(FWP)/K	456 460 464	M5456 M5460 M5464	E1828P E1838P E1848P	D1207P	H1259	P2428P P2438P P2448P	FW28	MH41	SM1014B #10 (MY1014B #70 ,SY7256)	

F007J: 為一般馬達,外置式機種 ; F007JD: 為加裝直驅伺服馬達機種

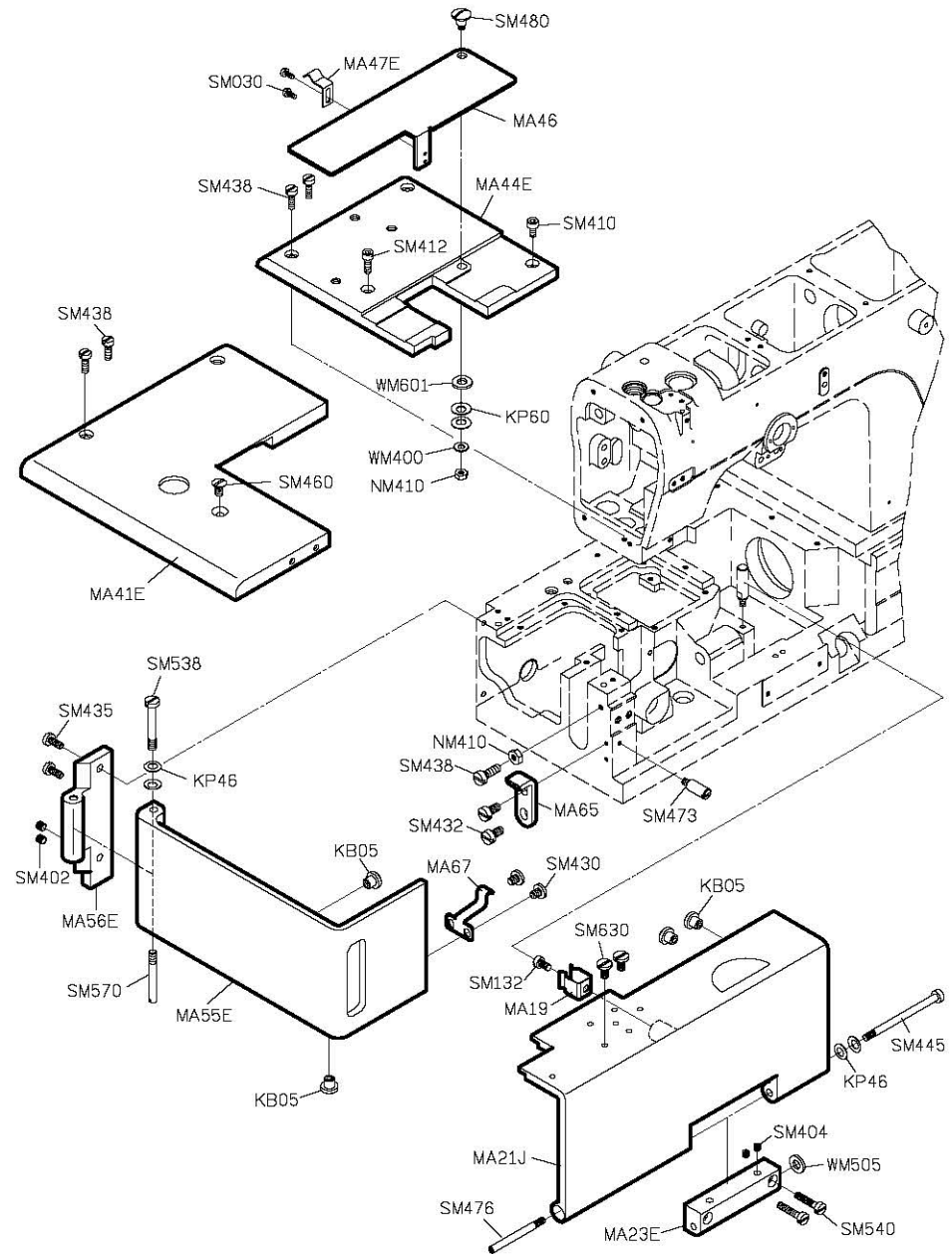
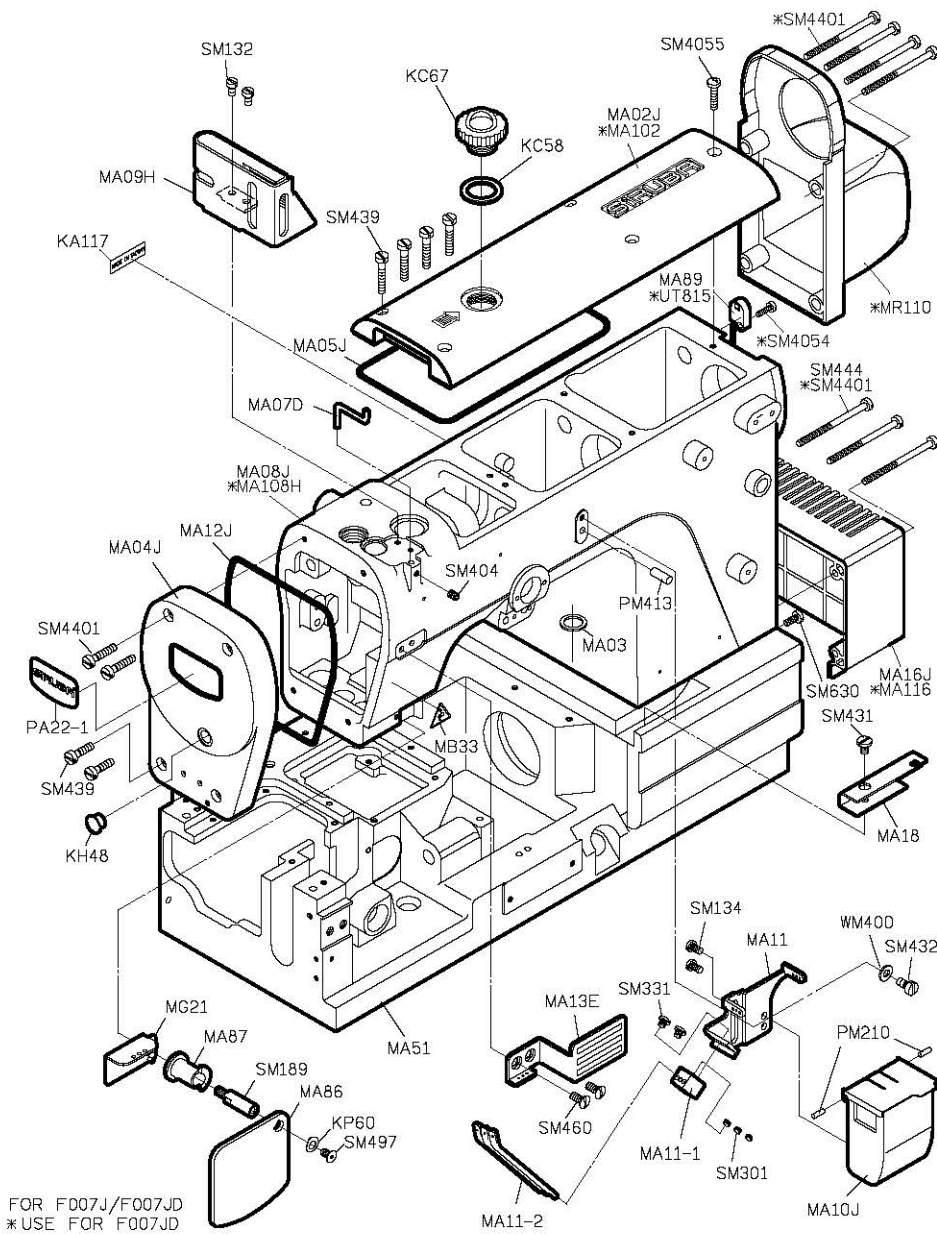

FOR F007J/F007JD
 *USE FOR F007JD

PARTS LIST FOR MB GROUP

PARTS LIST FOR MC GROUP

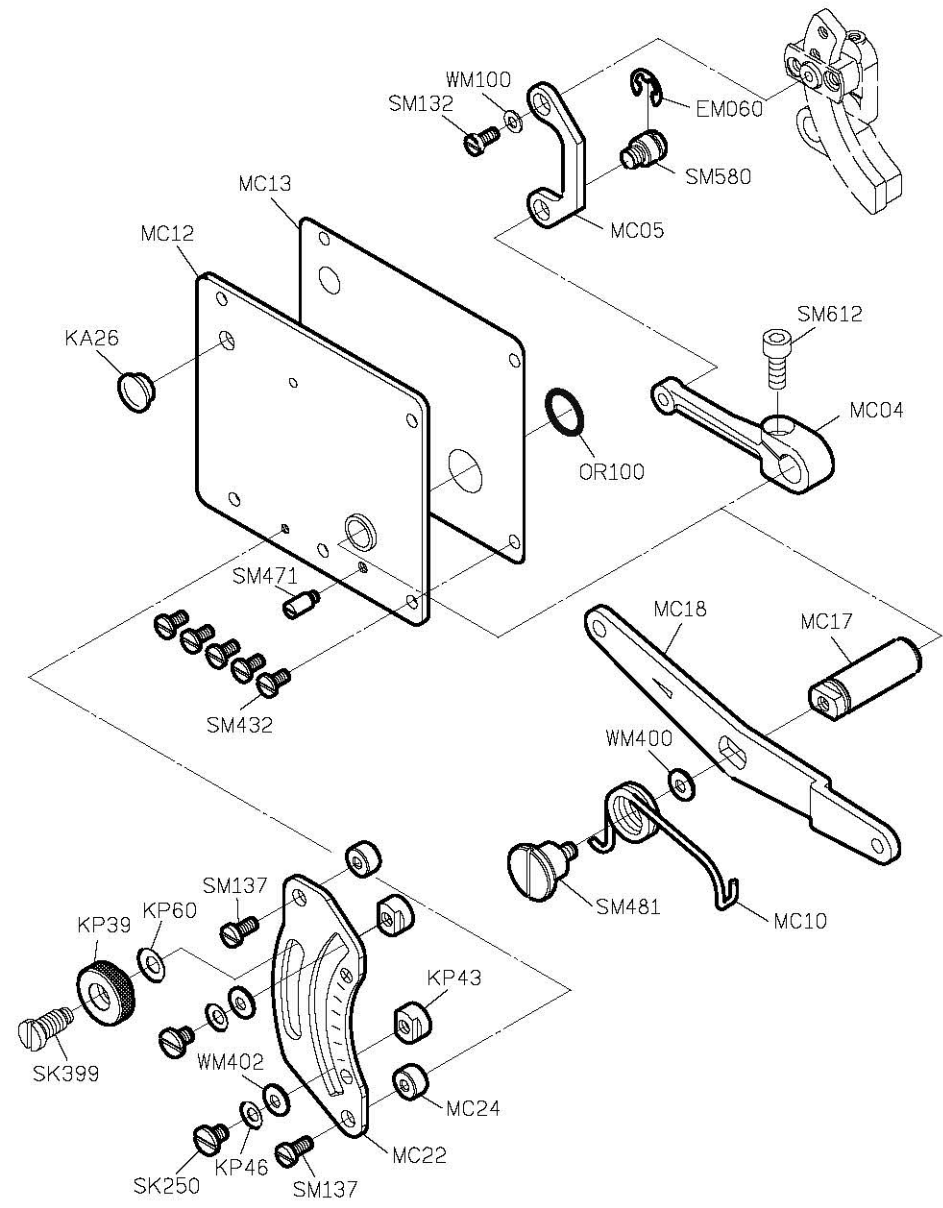
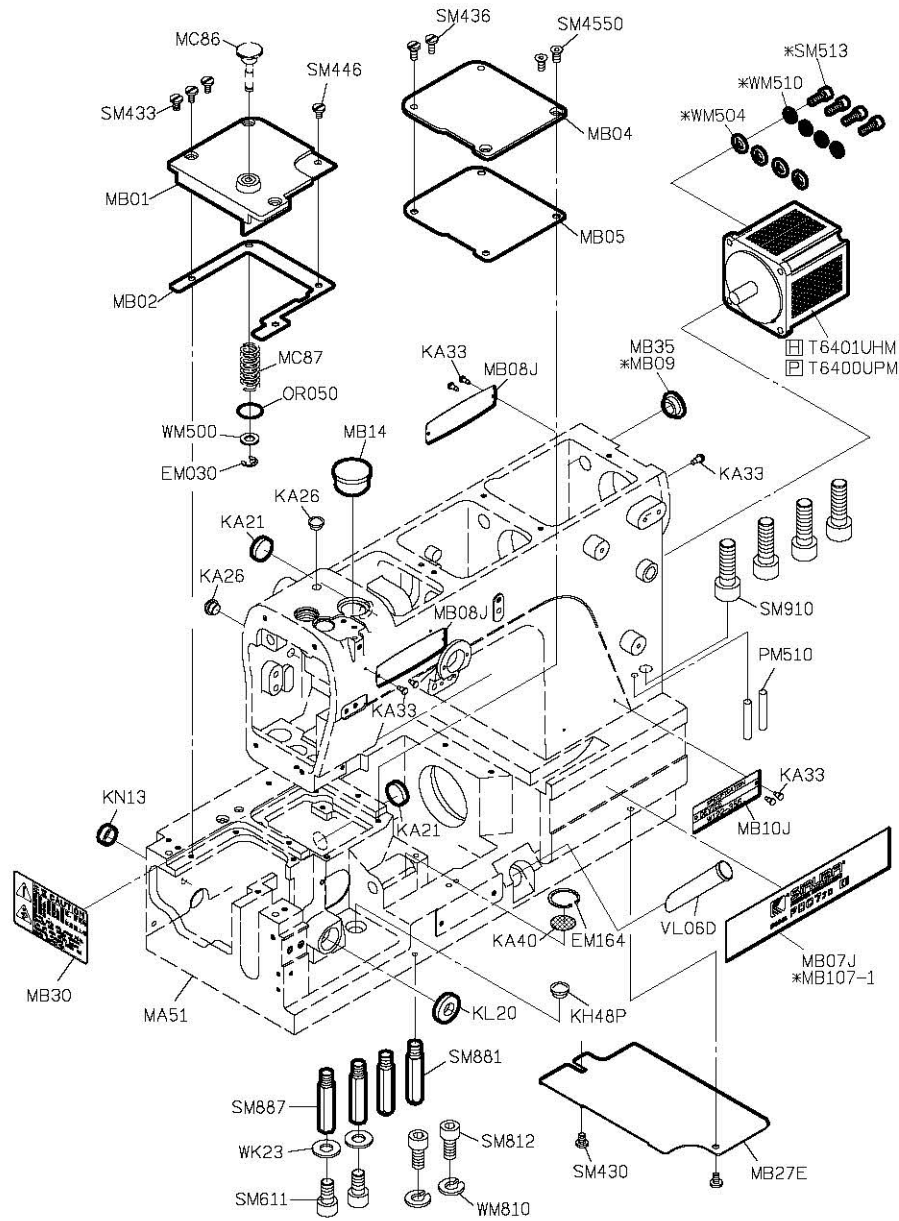

FOR F007J/F007JD □ FOR F007JD H牌馬達
 * USE FOR F007JD ○ FOR F007JD P牌馬達

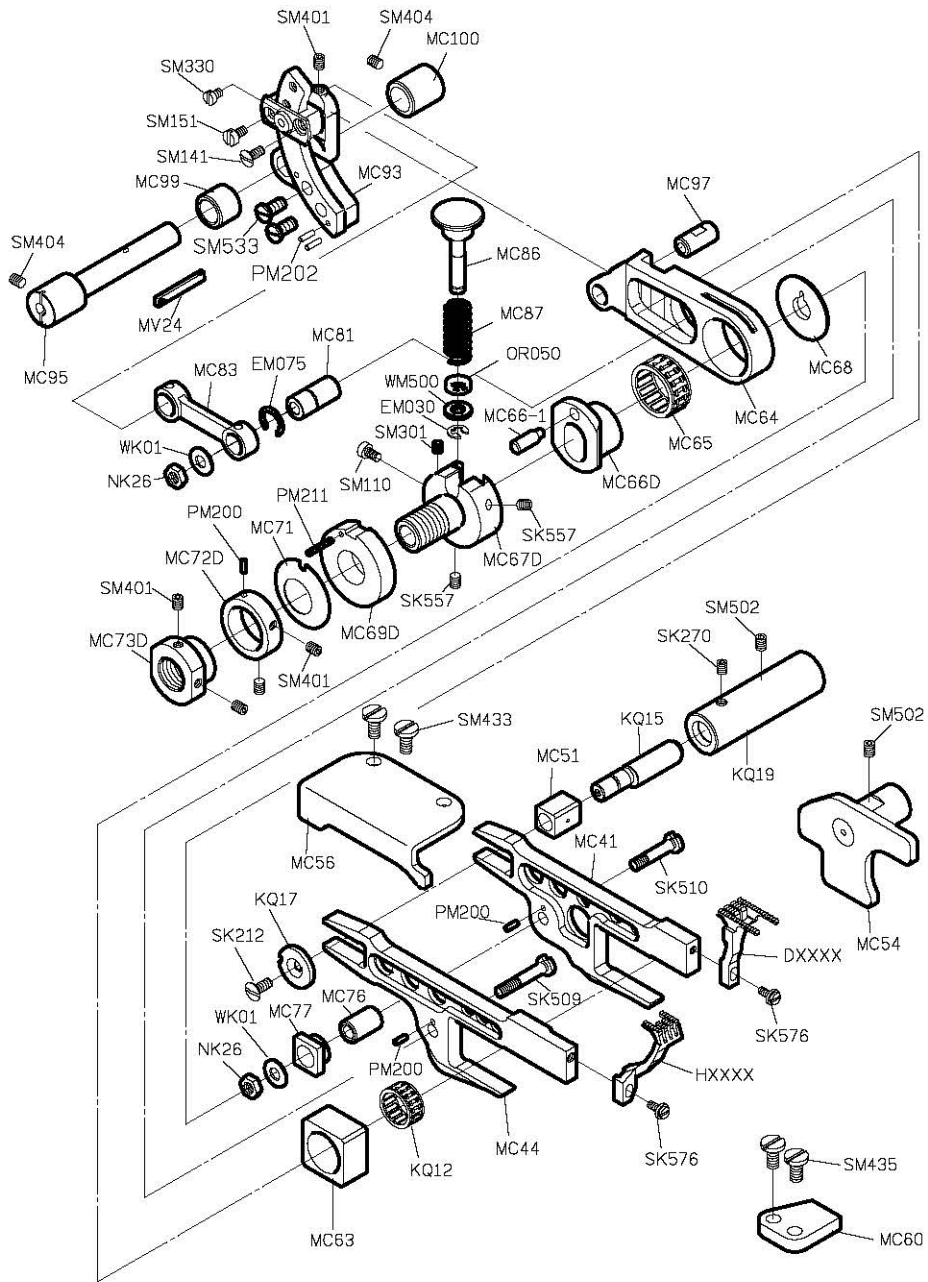

PARTS LIST Form Bell Group of: Superior Sewing Machine & Supply LLC

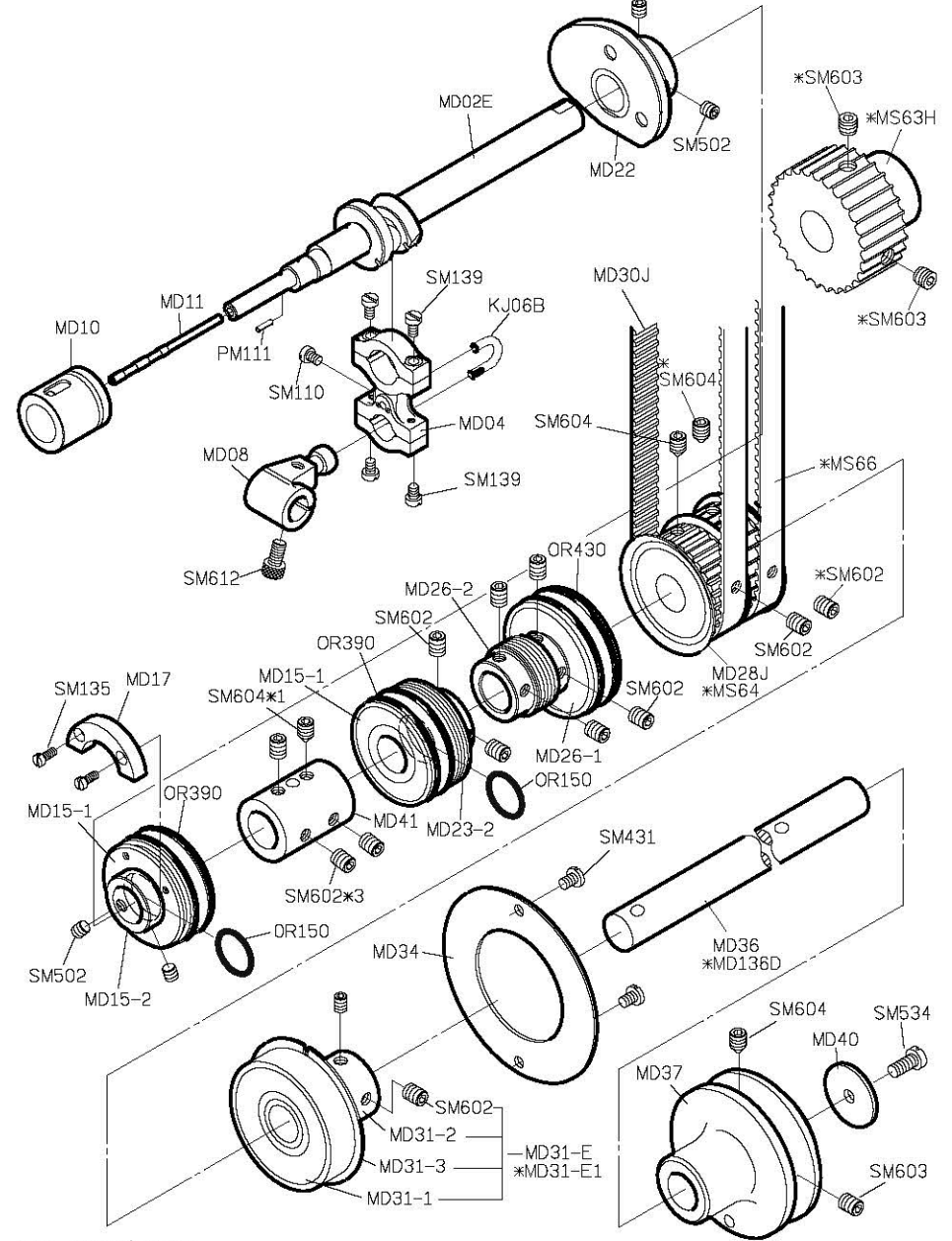

FOR F007J/F007JD
*USE FOR F007JD

PARTS LIST FOR MD GROUP

PARTS LIST FOR ME GROUP

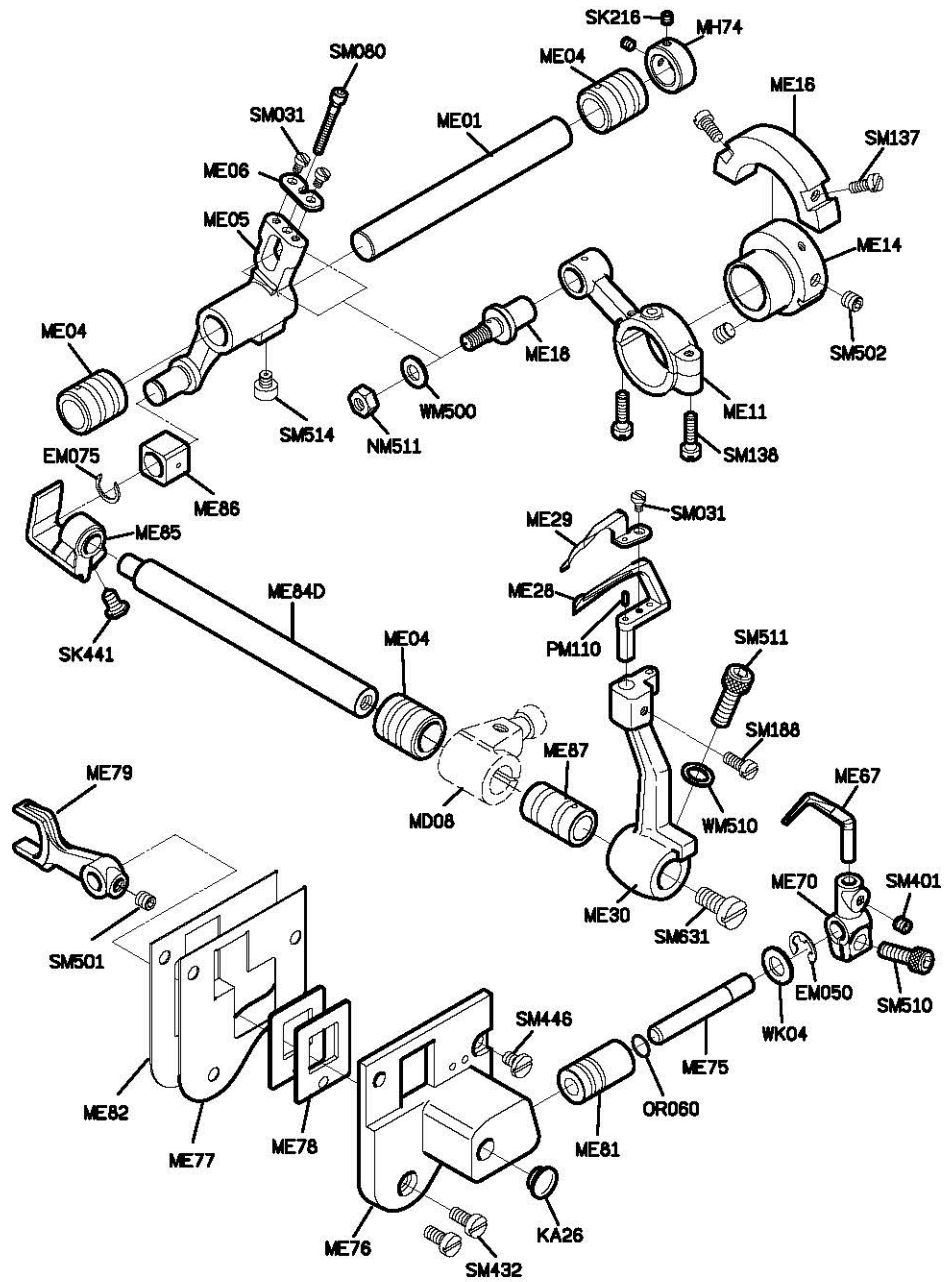

PARTS LIST FOR MF GROUP

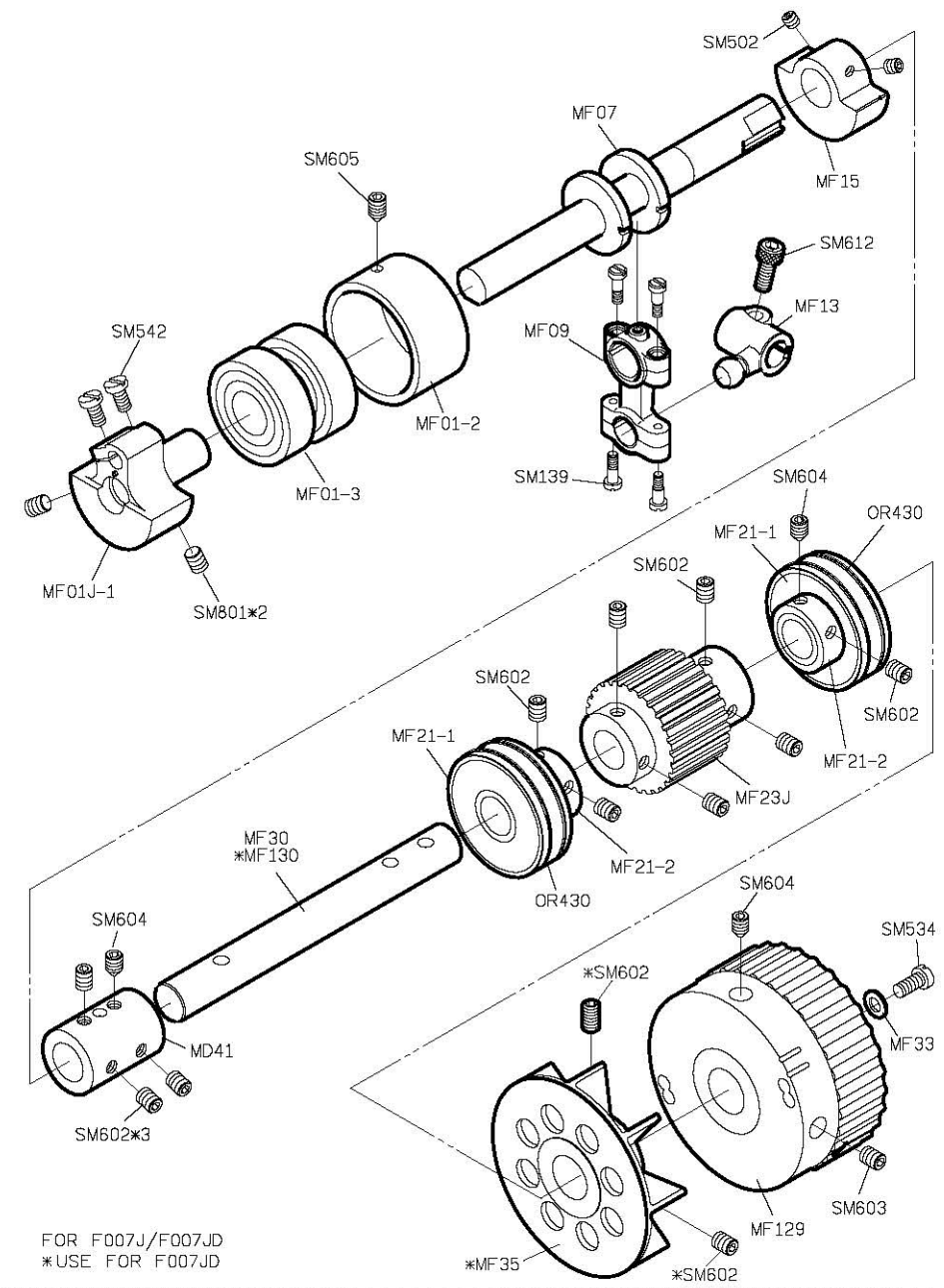

FOR F007J/F007JD
*USE FOR F007JD

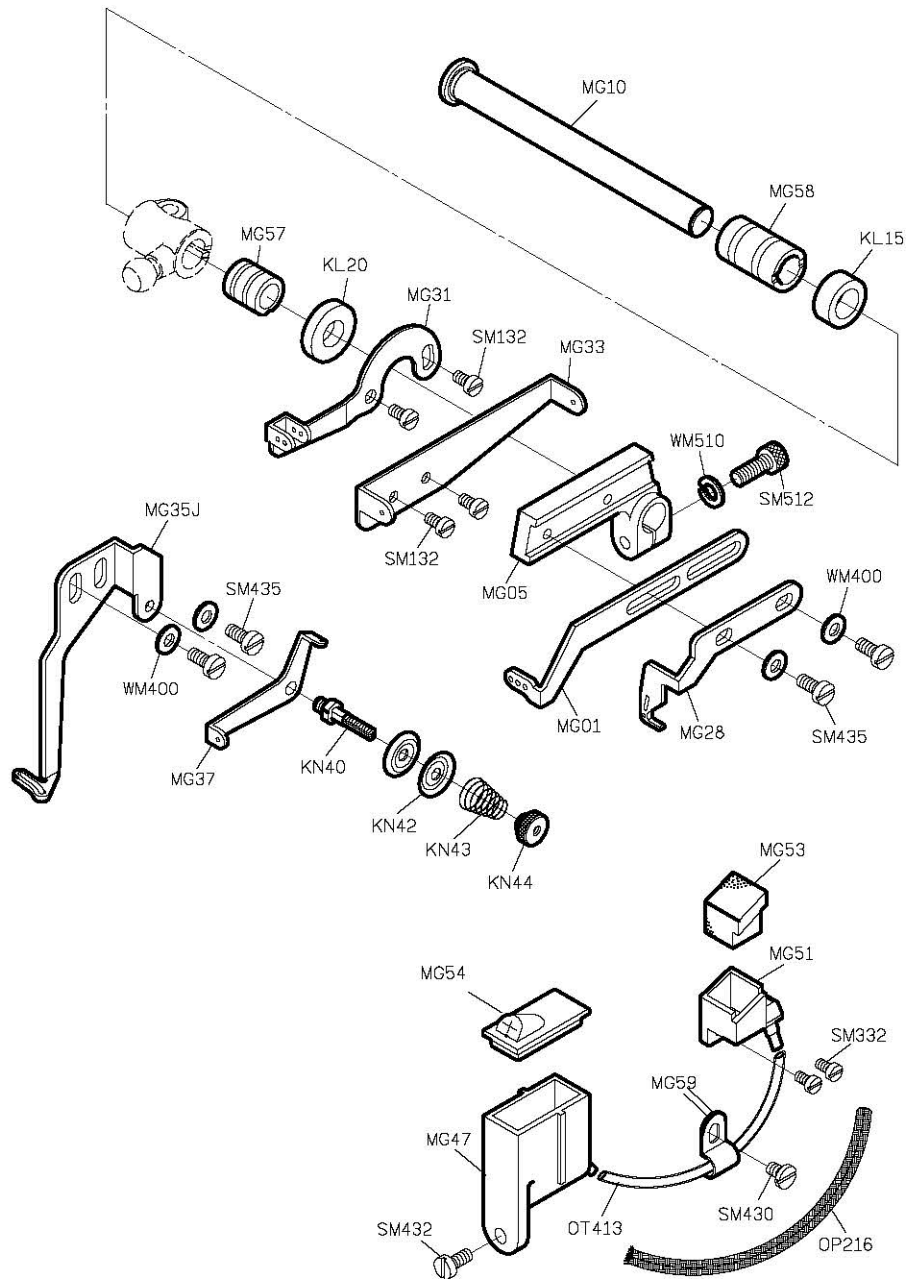

PARTS LIST From Gallery of: Superior Sewing Machine & Supply LLC

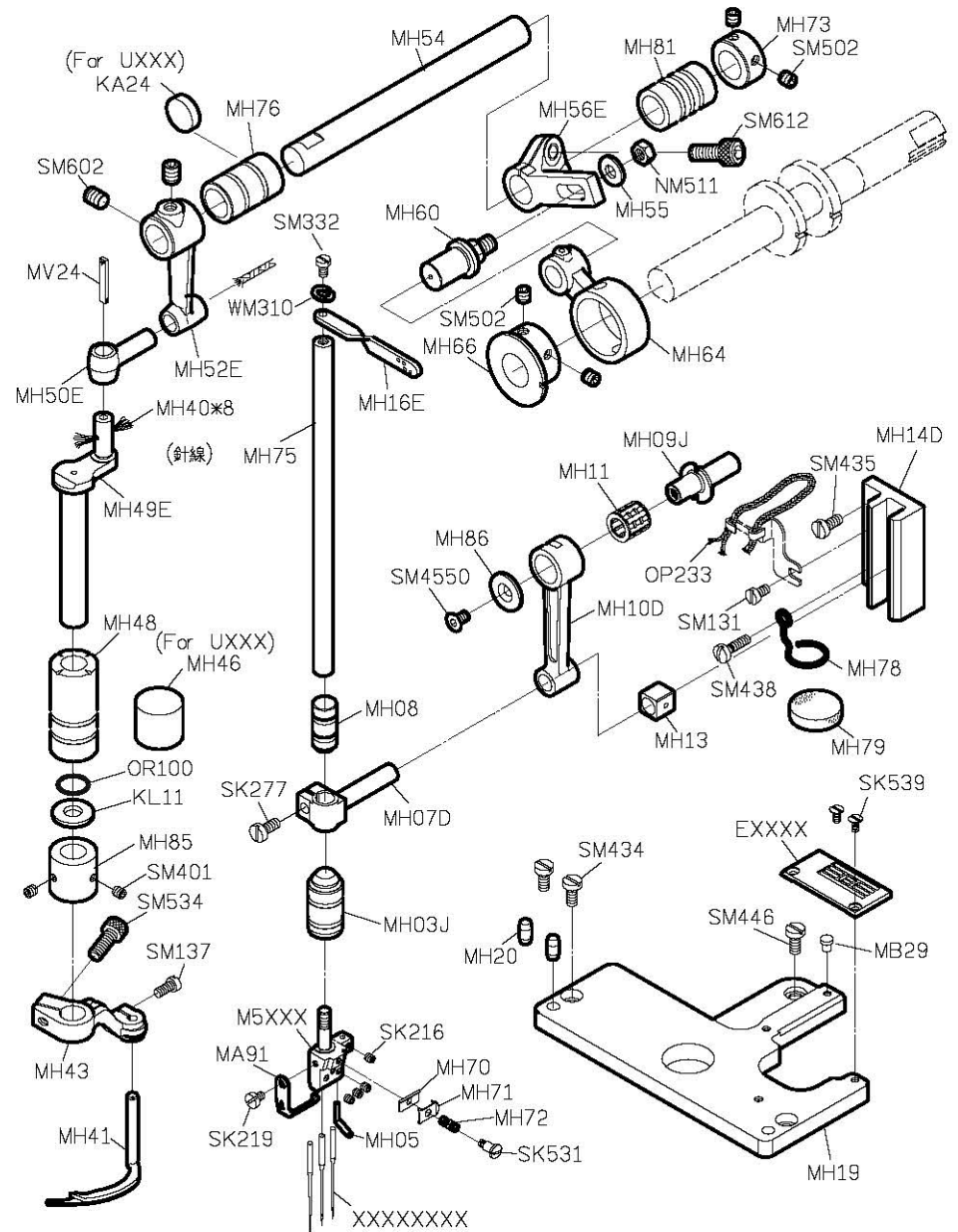

PARTS LIST FOR MH GROUP

PARTS LIST FOR MJ GROUP

PARTS LIST FOR MK GROUP

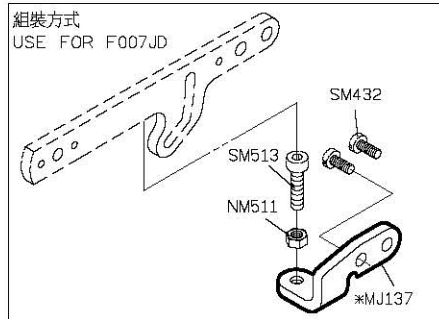
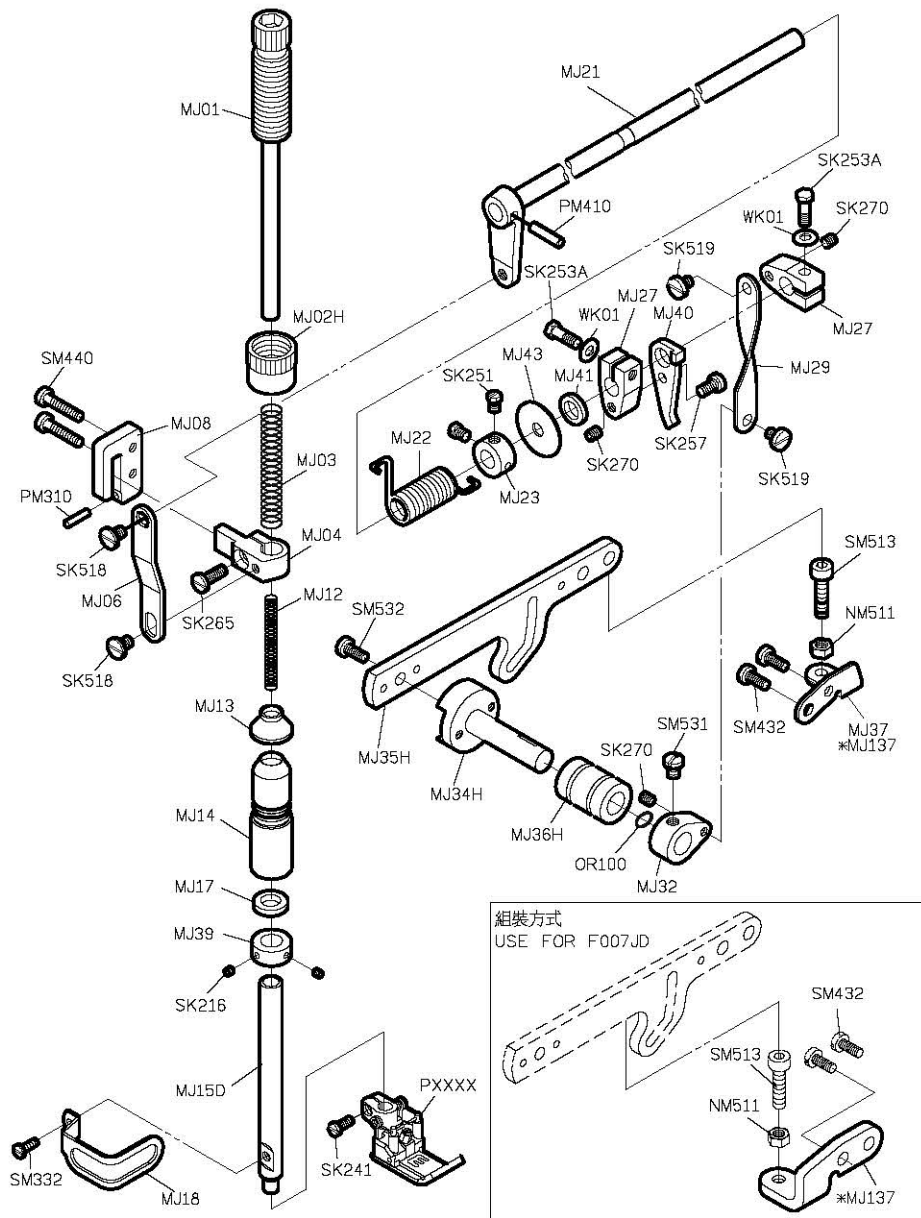

FOR F007J/F007JD
* USE FOR F007JD

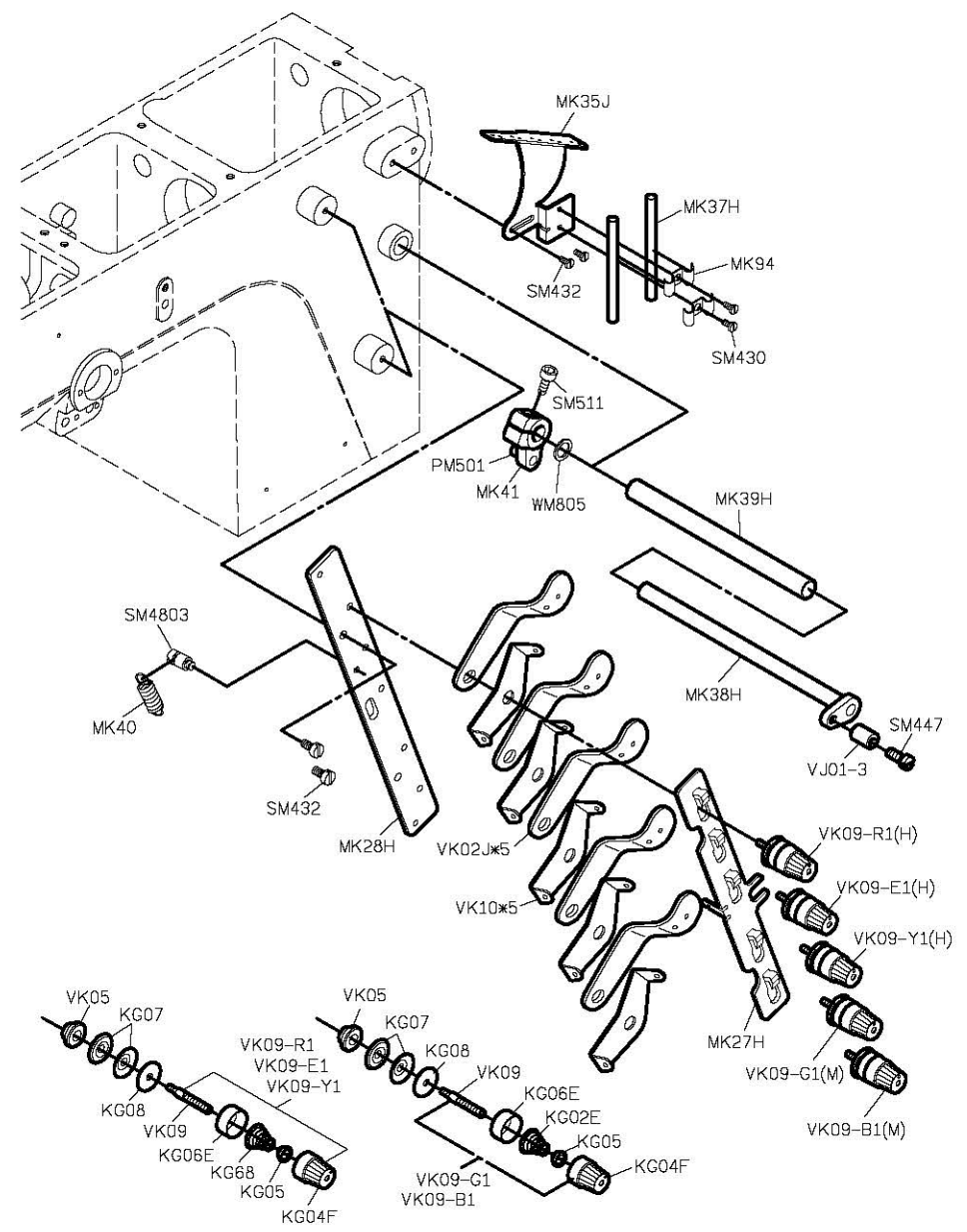

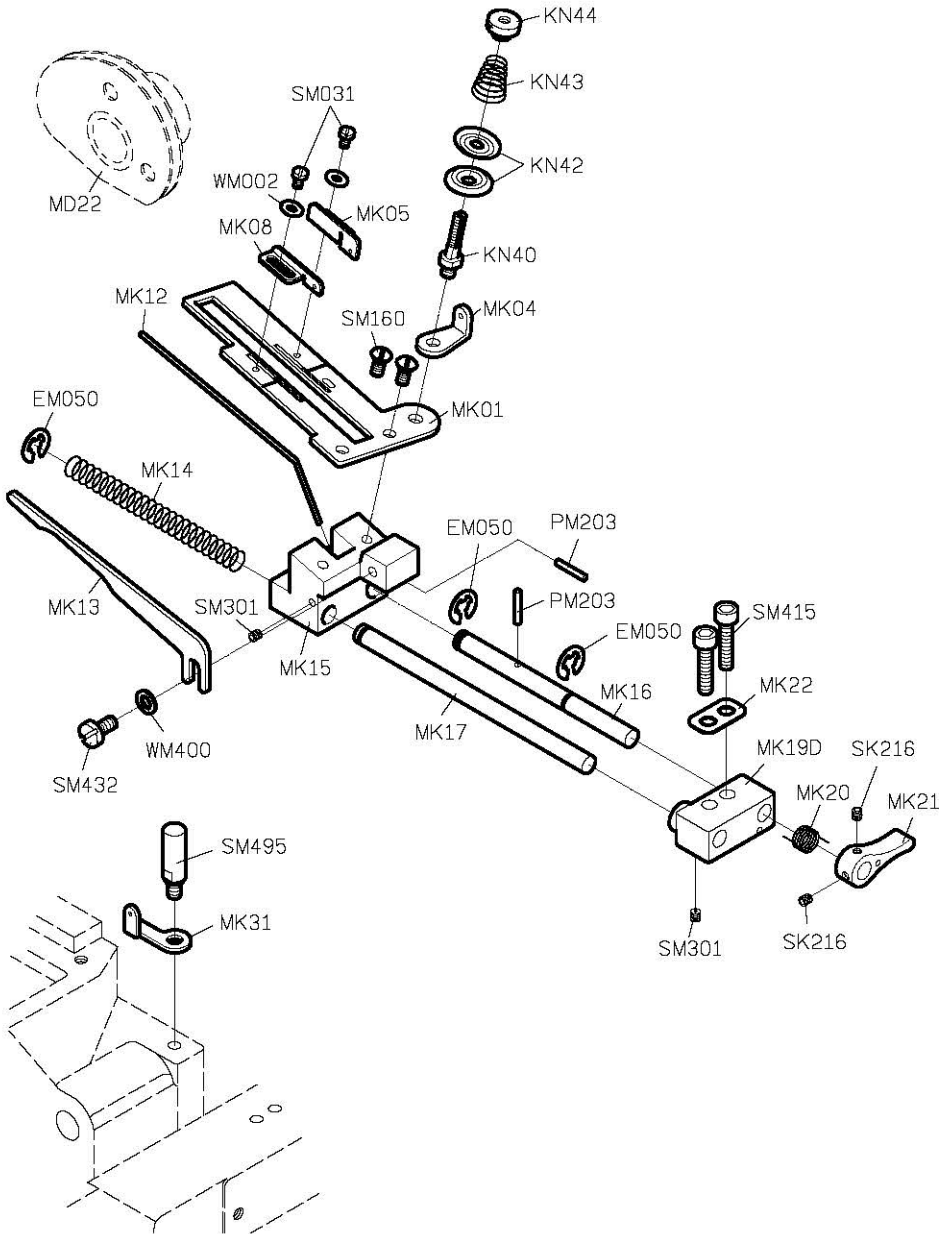

PARTS LIST

From the library of: Superior Sewing Machine & Supply LLC

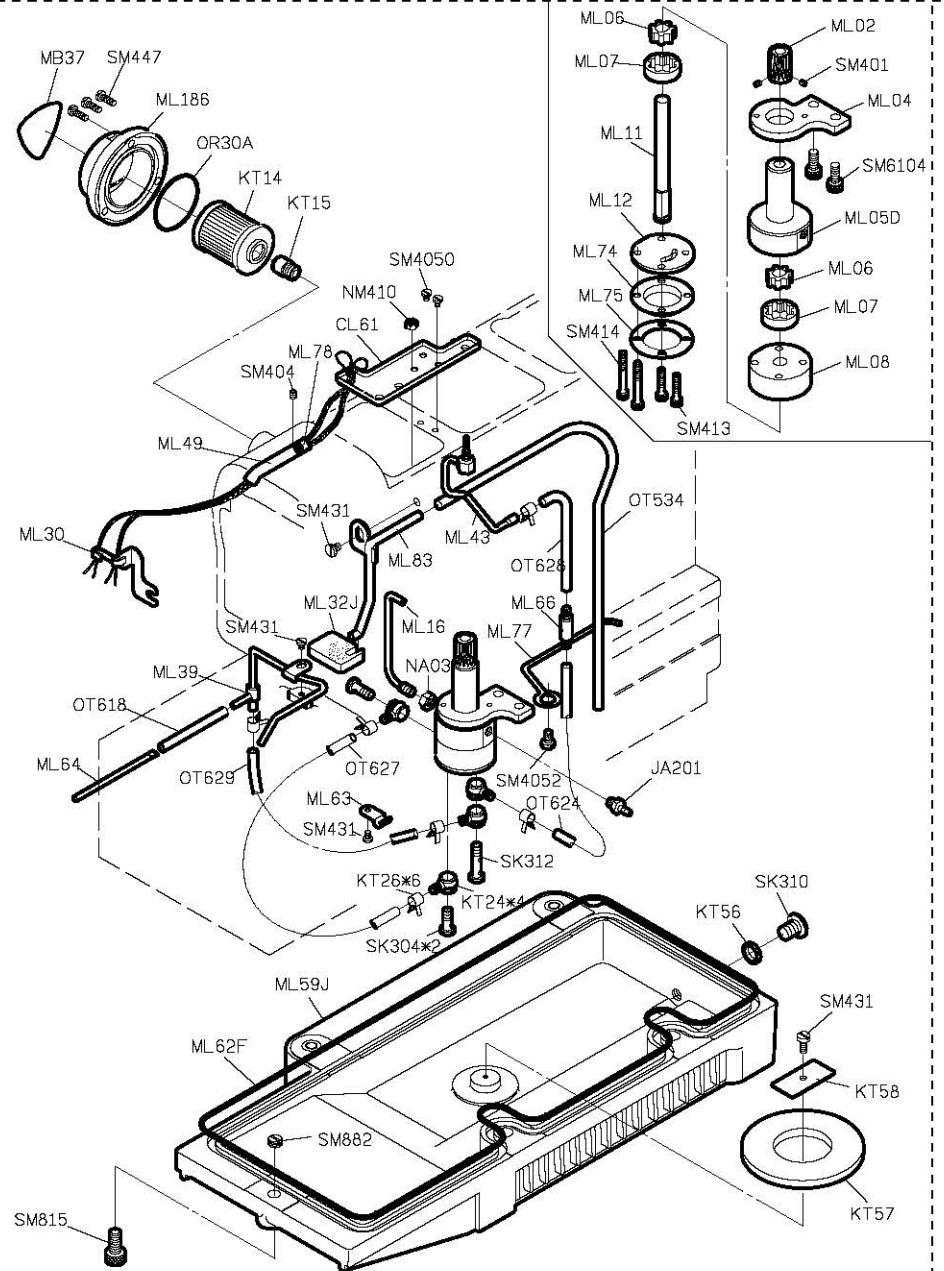

PARTS LIST

PARTS LIST FOR MN GROUP

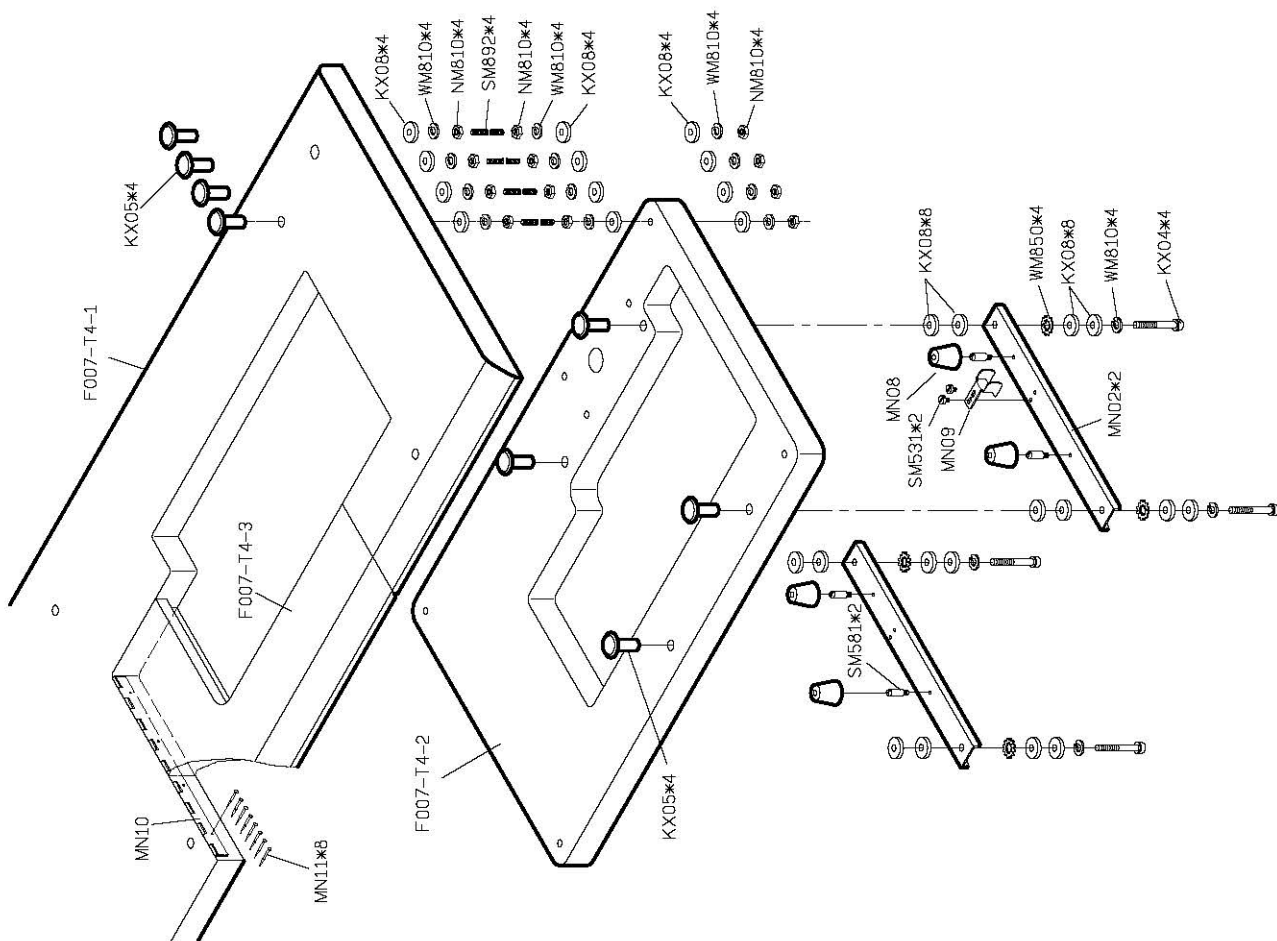

PARTS LIST FOR MN GROUP

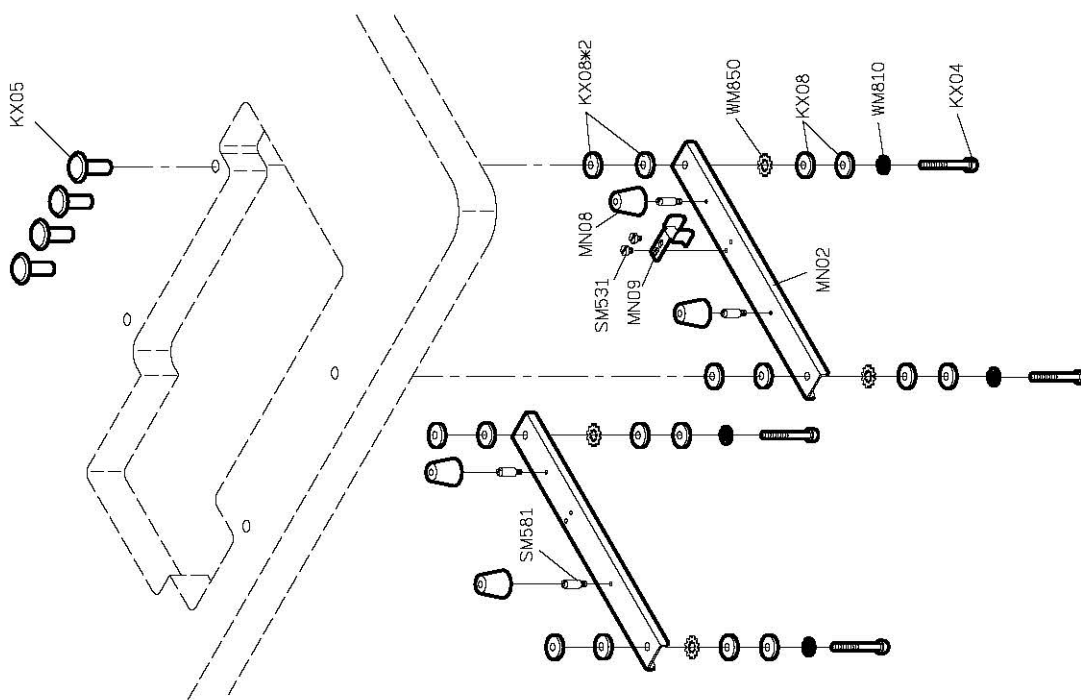

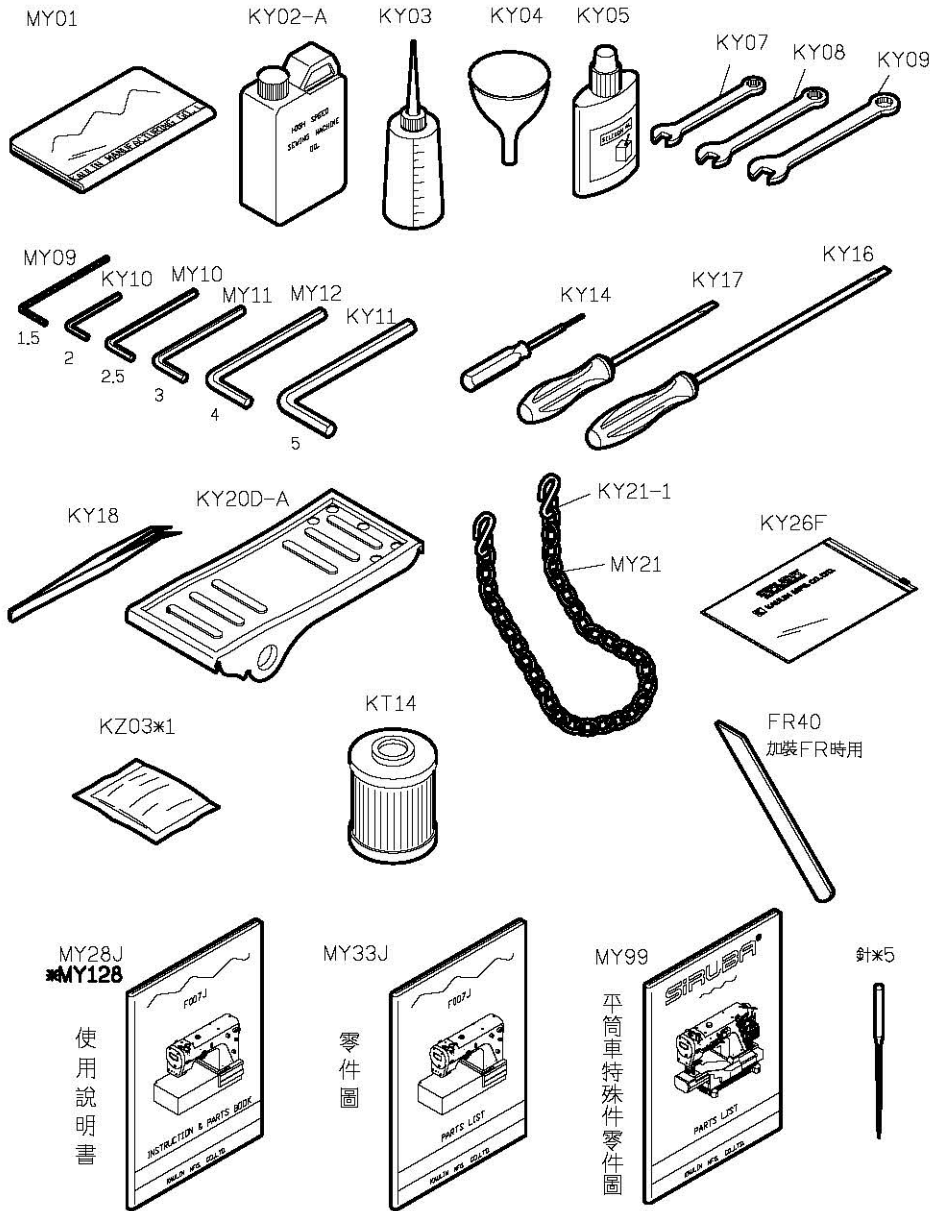

FOR F007J/F007JD
 *USE FOR F007JD

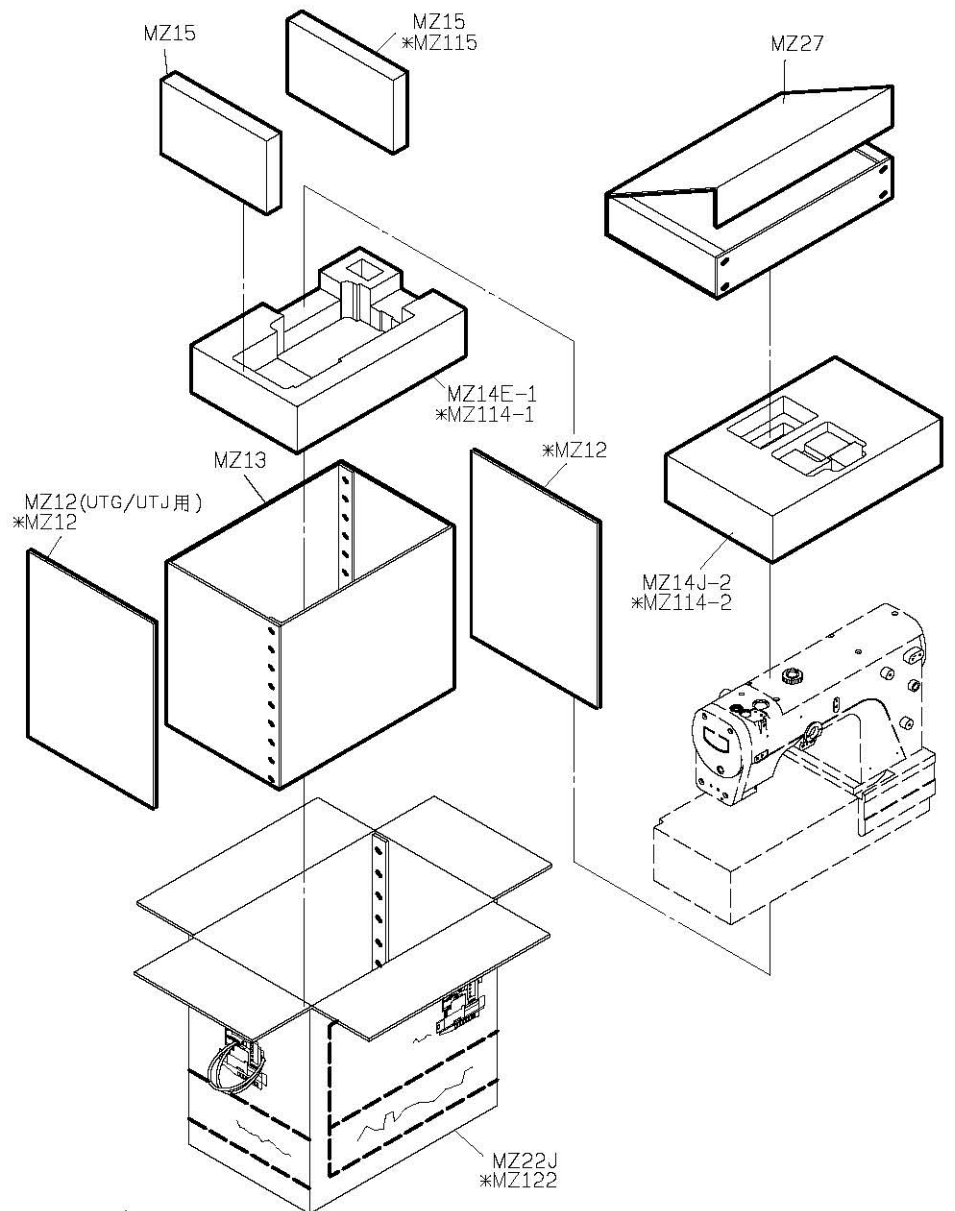

FOR F007J/F007JD
 *USE FOR F007JD

PARTS LIST FOR THREAD STAND GROUP

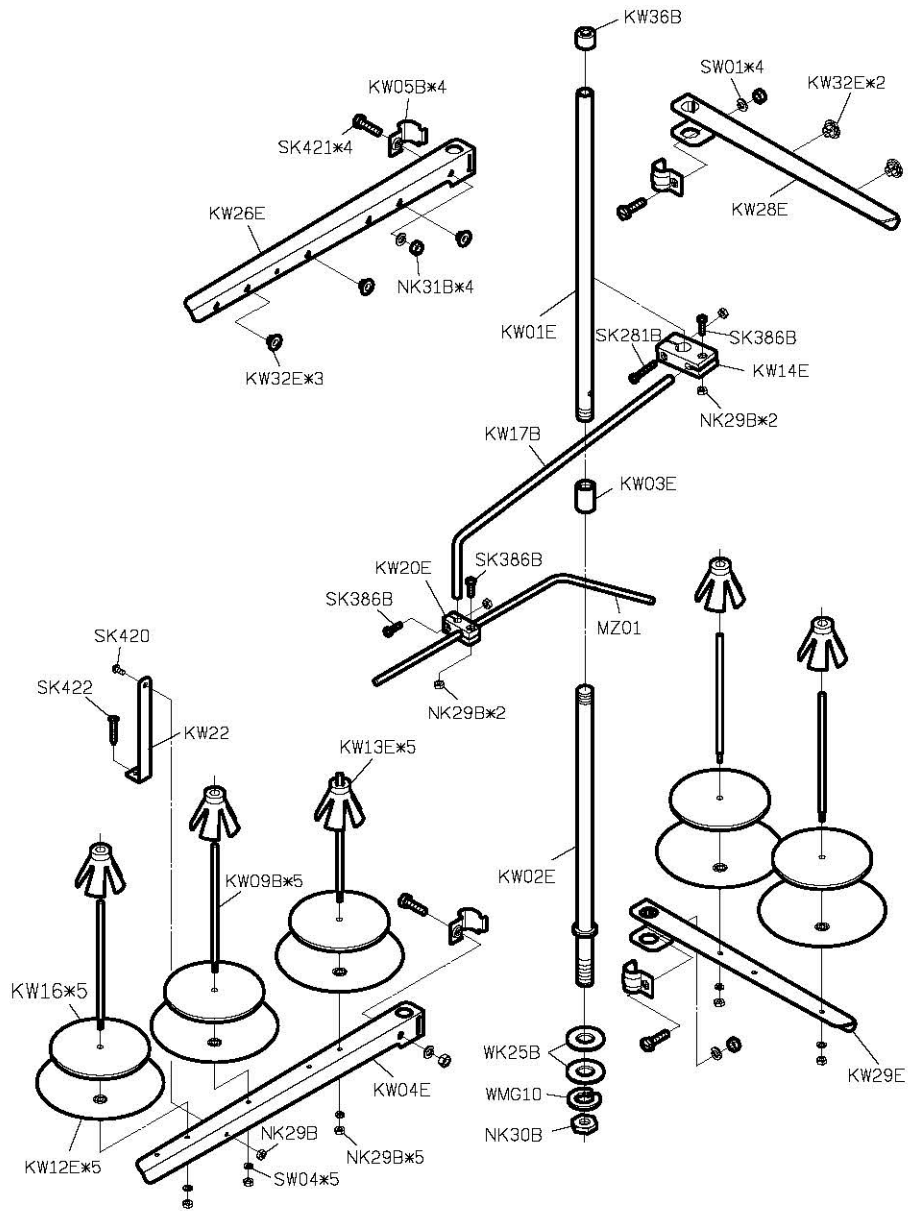



F007J/F007JD

高林股份有限公司 KAULIN MFG. CO., LTD.