

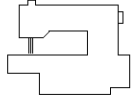





筒車規格件表 / CONVERSION CHART

P1

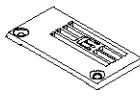
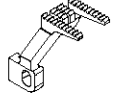
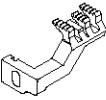
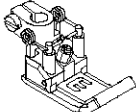
									
MODEL	SUB-CLASS	NEEDLE CLAMP	NEEDLE PLATE	MAIN FEED DOG	DIFF. FEED DOG	PRESSER FOOT	SPREADER	LOOPER	NEEDLE
機 型	規 格	針 座	針 板	主 送 具	差 送 具	押 具	上 叉	勾 針	針 號
C007J-W121 C858J-CH	356 364	M5356 M5364	E 3816P E 3817P	D 4206 D 4207	H 4458 H 4459	P2446-A P2447-A	MH41	MT01	UYX128GAS #10
C007J-U121 C858J-CH	356 364	M5356 M5364	E 3816P E 3817P	D 4206 D 4207	H 4458 H 4459	P2446-A P2447-A	—	MT01	UYX128GAS #10
C007J-W121 C858J-CH/UTP(UTR)	356 364	M5356 M5364	E 3816P E 3817P	D 4206 D 4207	H 4458 H 4459	P2446-A P2447-A	MH41	MT01	UYX128GAS #10
C007J-U121 C858J-CH/UTQ(UTS)	356 364	M5356 M5364	E 3816P E 3817P	D 4206 D 4207	H 4458 H 4459	P2446-A P2447-A	—	MT01	UYX128GAS #10
C007J-W122 C858J-CH	240 248 256 356 364	M5240 M5248 M5356 M5356 M5364	E 3524P E3525P E 3826S E 3826P E 3827P	D 4206 D 4206 D 4206 D 4206 D 4207	H 4458 H 4458 H 4458 H 4458 H 4459	P2544-A P2545-A P2446-A P2446-A P2447-A	MH41	MT01	UYX128GAS #10
C007J-U122 C858J-CH	240 248 256 356 364	M5240 M5248 M5356 M5356 M5364	E 3524P E3525P E 3826S E 3826P E 3827P	D 4206 D 4206 D 4206 D 4206 D 4207	H 4458 H 4458 H 4458 H 4458 H 4459	P2544-A P2545-A P2446-A P2446-A P2447-A	—	MT01	UYX128GAS #10
C007J-W122 C858J-CH/UTP(UTR)	240 248 256 356 364	M5240 M5248 M5356 M5356 M5364	E 3524P E3525P E 3826S E 3826P E 3827P	D 4206 D 4206 D 4206 D 4206 D 4207	H 4458 H 4458 H 4458 H 4458 H 4459	P2544-A P2545-A P2446-A P2446-A P2447-A	MH41	MT01	UYX128GAS #10

註：P2544-A/P2545-A為固定式押具舌，亦可使用活動式押具舌 P2565-A代替P2544-A/P2545-A

P2544-A/P2545-A is the fixed presser foot tongue. It can be replaced by the removable presser foot tongue P2565-A.

P2446-A/P2447-A為固定式押具舌，亦可使用活動式押具舌 P2466-A代替P2446-A/P2447-A

P2446-A/P2447-A is the fixed presser tongue. It can be replaced by the removable presser foot tongue P2466-A.

09/12/11

筒車規格件表/CONVERSION CHART

P2

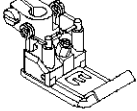
												
MODEL	SUB-CLASS	NEEDLE CLAMP	NEEDLE PLATE	MAIN FEED DOG	DIFF. FEED DOG	PRESSER FOOT	SPREADER	LOOPER	NEEDLE			
機 型	規 格	針 座	針 板	主 送 具	差 送 具	押 具	上 叉	勾 針	針 號			
C007J-U122 C858J /CH/UTQ(UTS)	240	M5240	E 3524P	D 4206	H4458	P2544-A	—	MT01	UYX128GAS #10			
	248	M5248	E3525P	D 4206	H4458	P2545-A						
	256	M5356	E 3826S	D 4206	H4458	P2446-A						
	356	M5356	E 3826P	D 4206	H4458	P2446-A						
	364	M5364	E 3827P	D 4207	H4459	P2447-A						
C007J-W122 C858J /CHA	356	M5356	E 3826Q	D 4206	H4458	P0216-A	MH41	MT01	UYX128GAS #10			
C007J-U122 C858J /CHA	356	M5356	E 3826Q	D 4206	H4458	P0416-A	—	MT01	UYX128GAS #10			
C007J-W123 C858J /CH	240	M5240	E 3534P	D 4206	H4458	P2544-A	MH41	MT01	UYX128GAS #10			
	248	M5248	E3535P	D 4206	H4458	P2545-A						
	356	M5356	E 3836P	D 4206	H4458	P2446-A						
	364	M5364	E 3837P	D 4207	H4459	P2447-A						
	240	M5240	E 3534P	D 4206	H4458	P2544-A				—	MT01	UYX128GAS #10
248	M5248	E3535P	D 4206	H4458	P2545-A							
356	M5356	E 3836P	D 4206	H4458	P2446-A							
364	M5364	E 3837P	D 4207	H4459	P2447-A							
C007J-U123 C858J /CH	356	M5356	E 3836P	D 4206	H4458	P2446-A	MH41	MT01	UYX128GAS #10			
240	M5240	E 3534P	D 2109	H2219	P2904-A							
248	M5248	E2325P	D 2109	H2219	P2905-A							
356	M5356	E 2326P	D 2110	H2220	P2906-A							
364	M5364	E2327P	D 2110	H2220	P2907-A							
C007J-W132 C858J /CHE	356	M5356	E 2326P	D 2110	H2220	P2906-A	MH41	MT01	UYX128GAS #10			
364	M5364	E2327P	D 2110	H2220	P2907-A							
C007J-U123 C858J /CH	240	M5240	E 3534P	D 4206	H4458	P2544-A				—	MT01	UYX128GAS #10
248	M5248	E3535P	D 4206	H4458	P2545-A							
356	M5356	E 3836P	D 4206	H4458	P2446-A							
364	M5364	E 3837P	D 4207	H4459	P2447-A							
C007J-U123 C858J /CH	356	M5356	E 3836P	D 4206	H4458	P2446-A	MH41	MT01	UYX128GAS #10			
240	M5240	E 3534P	D 4206	H4458	P2544-A							
248	M5248	E3535P	D 4206	H4458	P2545-A							
356	M5356	E 3836P	D 4206	H4458	P2446-A							
364	M5364	E 3837P	D 4207	H4459	P2447-A							
C007J-W132 C858J /CHE	356	M5356	E 2326P	D 2110	H2220	P2906-A	MH41	MT01	UYX128GAS #10			
364	M5364	E2327P	D 2110	H2220	P2907-A							
C007J-U132 C858J /CHE/UTP(UTR)	240	M5240	E 3534P	D 4206	H4458	P2544-A				—	MT01	UYX128GAS #10
248	M5248	E3535P	D 4206	H4458	P2545-A							
356	M5356	E 3836P	D 4206	H4458	P2446-A							
364	M5364	E 3837P	D 4207	H4459	P2447-A							
C007J-U132 C858J /CHE/UTP(UTR)	356	M5356	E 3836P	D 4206	H4458	P2446-A	MH41	MT01	UYX128GAS #10			
364	M5364	E 3837P	D 4207	H4459	P2447-A							

註：P2544-A/P2545-A 為固定式押具舌，亦可使用活動式押具舌 P2565-A 代替 P2544-A/P2545-A。
 P2544-A/P2545-A is the fixed presser foot tongue. It can be replaced by the removable presser foot tongue P2565-A.
 P2446-A/P2447-A 為固定式押具舌，亦可使用活動式押具舌 P2466-A 代替 P2446-A/P2447-A。
 P2446-A/P2447-A is the fixed presser foot tongue. It can be replaced by the removable presser foot tongue P2466-A.

筒車規格件表 / CONVERSION CHART







P3

									
MODEL	SUB-CLASS	NEEDLE CLAMP	NEEDLE PLATE	MAIN FEED DOG	DIFF. FEED DOG	PRESSER FOOT	SPREADER	LOOPER	NEEDLE
機 型	規 格	針 座	針 板	主 送 具	差 送 具	押 具	上 叉	勾 針	針 號
C007J-W152 C858J /CZ/UTP/RLQ	356 364	M5356 M5364	E4326P E4327P	D3216 D3217	H3262 H3263	P2416-A P2417-A	MH41	MT01	UYX128GAS #10
C007J-U152 C858J /CZ/UTQ/RLQ	356 364	M5356 M5364	E4326P E4327P	D3216 D3217	H3262 H3263	P2416-A P2417-A	—	MT01	UYX128GAS #10
C007J-W152 C858J /CZ/CLA/UTP/RLQ	356 364	M5356 M5364	E4326P E4327P	D3216 D3217	H3262 H3263	P2416-A P2417-A	MH41	MT01	UYX128GAS #10
C007J-U152 C858J /CZ/CLA/UTQ/RLQ	356 364	M5356 M5364	E4326P E4327P	D3216 D3217	H3262 H3263	P2416-A P2417-A	—	MT01	UYX128GAS #10
C007J-W162 C858J	240 248 356 364	M5240 M5248 M5356 M5364	E3544 E3545 E3846 E3847	D4206 D4206 D4206 D4207	H4458 H4458 H4458 H4459	P2544-A P2545-A P2446-A P2447-A	MH41	MT01A	TVX5 #14~16
C007J-U162 C858J	240 248 356 364	M5240 M5248 M5356 M5364	E3544 E3545 E3846 E3847	D4206 D4206 D4206 D4207	H4458 H4458 H4458 H4459	P2544-A P2545-A P2446-A P2447-A	—	MT01A	TVX5 #14~16
C007J-W162 C858J /UTP (UTR)	248 356 364	M5240 M5248 M5356 M5364	E3544 E3545 E3846 E3847	D4206 D4206 D4206 D4207	H4458 H4458 H4458 H4459	P2544-A P2545-A P2446-A P2447-A	MH41	MT01A	TVX5 #14~16
C007J-U162 C858J /UTQ (UTS)	240 248 356 364	M5240 M5248 M5356 M5364	E3544 E3545 E3846 E3847	D4206 D4206 D4206 D4207	H4458 H4458 H4458 H4459	P2544-A P2545-A P2446-A P2447-A	—	MT01A	TVX5 #14~16

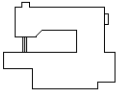
註：P2544-A/P2545-A為固定式押具舌，亦可使用活動式押具舌 P2565-A代替 P2544-A/P2545-A
 P2544-A/P2545-A is the fixed presser foot tongue. It can be replaced by the removable presser foot tongue P2565-A.
 P2446-A/P2447-A為固定式押具舌，亦可使用活動式押具舌 P2466-A代替 P2446-A/P2447-A
 P2446-A/P2447-A is the fixed presser tongue. It can be replaced by the removable presser foot tongue P2466-A.

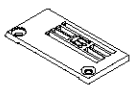
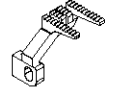
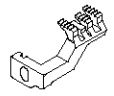
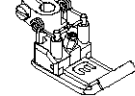
09/12/11

筒車規格件表/CONVERSION CHART

									
MODEL	SUB-CLASS	NEEDLE CLAMP	NEEDLE PLATE	MAIN FEED DOG	DIFF. FEED DOG	PRESSER FOOT	SPREADER	LOOPER	NEEDLE
機 型	規 格	針 座	針 板	主 送 具	差 送 具	押 具	上 叉	勾 針	針 號
C007J-W222 C858J /CQ	240	M5240	E4124P	D3216	H3362	P1814-A	MH41	MT01	UYX128GAS #10
C007J-U222 C858J /CQ	248 356 364	M5248 M5356 M5364	E4125P E4426P E4427P	D3216 D3216 D3217	H3362 H3362 H3363	P1815-A P2116-A P2117-A	—		
C007J-W222 C858J /CQA/CLA	256	M5356	E2326Q	D2110	H2220Q	P2906Q-A	MH41	MT01A	TVX5 #14
C007J-W322 C858J /CC	356 364	M5356 M5364	E2826P E2827P	D2107L D2107L	H3259M H3259M	P2456-A P2457-A	MH41	MT01	UYX128GAS #10
C007J-U322 C858J /CC	356 364	M5356 M5364	E2826P E2827P	D2107L D2107L	H3259M H3259M	P2456-A P2457-A	—	MT01	UYX128GAS #10
C007J-W322 C858J /CC/UTP(UTR)	356 364	M5356 M5364	E2826P E2827P	D2107L D2107L	H3259M H3259M	P2456-A P2457-A	MH41	MT01	UYX128GAS #10
C007J-U322 C858J /CC/UTQ(UTS)	356 364	M5356 M5364	E2826P E2827P	D2107L D2107L	H3259M H3259M	P2456-A P2457-A	—	MT01	UYX128GAS #10



註(1) : P2544-A/P2545-A為固定式押具舌,亦可使用活動式押具舌 P2565-A代替 P2544-A/P2545-A
 P2544-A/P2545-A is the fixed presser foot tongue. It can be replaced by the removable presser foot tongue P2565-A.
 P2446-A/P2447-A為固定式押具舌,亦可使用活動式押具舌 P2466-A代替 P2446-A/P2447-A
 P2446-A/P2447-A is the fixed presser tongue. It can be replaced by the removable presser foot tongue P2466-A.

09/12/11

註(2) : C007J-W/U322A-³⁵⁶/₃₆₄ /CC 時, 該針板與送具改用 C007J-W/U122-³⁵⁶/₃₆₄ 之針板與送具, 加附CHJ-A
 When W/U322A-³⁵⁶/₃₆₄ /CC, The needle plate and the feed dog have to be replaced by C007J-W/U122-³⁵⁶/₃₆₄ needle plate and the feed dog,
 with CHJ-A attached.

筒車規格件表/CONVERSION CHART

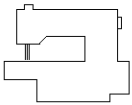

P5-1

									
MODEL	SUB-CLASS	NEEDLE CLAMP	NEEDLE PLATE	MAIN FEED DOG	DIFF. FEED DOG	PRESSER FOOT	SPREADER	LOOPER	NEEDLE
機 型	規 格	針 座	針 板	主送具	差送具	押 具	上 叉	勾 針	針 號
W512 /FE(FFC)	232 240 356 364	M5232 M5240 M5356 M5364	E3523R E3524R E3826R E3827R	D4205 D4206 D4206 D4207	H4457 H4458 H4458 H4459	P2913-A P2914-A P3216-A P3217-A	MH41	MT01	UYX128GAS #10
U512 /FE(FFC)	240 356 364	M5240 M5356 M5364	E3524R E3826R E3827R	D4206 D4206 D4207	H4458 H4458 H4459	P3414-A P3716-A P3717-A	—	MT01	UYX128GAS #10
W522 /FE(FFC)/CR/CL	356 364	M5356 M5364	E6426R E6427R	D3222	H3268	P3816R-A1 P3817R-A1	MH41	MT01	UYX128GAS #10
U522 /FE(FFC)/CR/CL	356 364	M5356 M5364	E6426R E6427R	D3222	H3268	P3816R-A1 P3817R-A1	—	MT01	UYX128GAS #10
W532/ CR/UTP/CL/RLP/CX	232 356 364	M5232 M5356 M5364	E6423R E6426R E6427R	D3219 D3222	H3265 H3268	P3813R-A P3816R-A P3817R-A	MH41	MT01	UYX128GAS #10
U532/ CR/UTQ/CL/RLP/CX	356 364	M5356 M5364	E6426R E6427R	D3222	H3268	P3816R-A P3817R-A	MH41	MT01	UYX128GAS #10
W922/ CW	456 464	M5456 M5464	E1828P E1848P	D2107M	H4459M	P2428Q-A P2448Q-A	MH41	MT01B	SMX1014B#10 (MY1014B#70,SY7256)
W922/ CW/UTP	456 464	M5456 M5464	E1828P E1848P	D2107M	H4459M	P2428Q-A P2448Q-A	MH41	MT01B	SMX1014B#10 (MY1014B#70,SY7256)
W922/ CW/UTR	456 464	M5456 M5464	E1828P E1848P	D2107M	H4459M	P2428Q-A P2448Q-A	MH41	MT01B	SMX1014B#10 (MY1014B#70,SY7256)

10/07/08



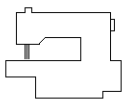
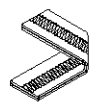
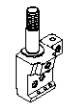
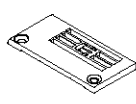
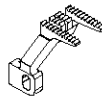
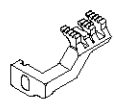
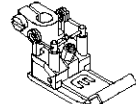
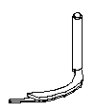



筒車規格件表/CONVERSION CHART

P6

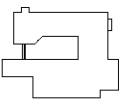
									
MODEL	SUB-CLASS	NEEDLE CLAMP	NEEDLE PLATE	MAIN FEED DOG	DIFF. FEED DOG	PRESSER FOOT	SPREADER	LOOPER	NEEDLE
機 型	規 格	針 座	針 板	主 送 具	差 送 具	押 具	上 叉	勾 針	針 號
C007J-W512 C858J/FE(FFC)	232 240 356 364	M5232 M5240 M5356 M5364	E 3523R E 3524R E 3826R E3827R	D 4205 D 4206 D 4206 D 4207	H4457 H4458 H4458 H4459	P2913-A P2914-A P3216-A P3217-A	MH41	MT01	UYX128GAS #10
C007J-U512 C858J/FE(FFC)	240 356 364	M5240 M5356 M5364	E 3524R E 3826R E3827R	D 4206 D 4206 D 4207	H4458 H4458 H4459	P3414-A P3716-A P3717-A	—	MT01	UYX128GAS #10
C007J-W522 C858J/FE(FFC)/CR/CL	356 364	M5356 M5364	E6426R E6427R	D3222	H3268	P3816R-A P3817R-A	MH41	MT01	UYX128GAS #10
C007J-U522 C858J/FE(FFC)/CR/CL	356 364	M5356 M5364	E6426R E6427R	D3222	H3268	P3816R-A P3817R-A	—	MT01	UYX128GAS #10
C007J-W532/ C858J/CR/UTP/CL/RLP/CX	232 356 364	M5232 M5356 M5364	E 6423R E6426R E6427R	D3219 D3222	H3265 H3268	P3813R-A P3816R-A P3817R-A	MH41	MT01	UYX128GAS #10
C007J-U532/ C858J/CR/UTQ/CL/RLP/CX	356 364	M5356 M5364	E6426R E6427R	D3222	H3268	P3816R-A P3817R-A	MH41	MT01	UYX128GAS #10
C007J-W922/ C858J CW	456 464	M5456 M5464	E1828P E1848P	D2107M	H4459M	P2428Q-A P2448Q-A	MH41	MT01B	SMX1014B#10 (MY1014B#70,SY7256)
C007J-W922/ C858J CW/UTP	456 464	M5456 M5464	E1828P E1848P	D2107M	H4459M	P2428Q-A P2448Q-A	MH41	MT01B	SMX1014B#10 (MY1014B#70,SY7256)
C007J-W922/ C858J CW/UTR	456 464	M5456 M5464	E1828P E1848P	D2107M	H4459M	P2428Q-A P2448Q-A	MH41	MT01B	SMX1014B#10 (MY1014B#70,SY7256)

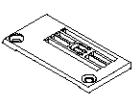
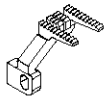
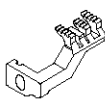
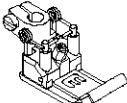
09/12/11

筒車規格件表 / CONVERSION CHART

									
MODEL	SUB-CLASS	NEEDLE CLAMP	NEEDLE PLATE	MAIN FEED DOG	DIFF. FEED DOG	PRESSER FOOT	SPREADER	LOOPER	NEEDLE
機型	規格	針座	針板	主送具	差送具	押具	上叉	勾針	針號
C007J-W811 C858J /CRL/RL	248 356 364	M5248 M5356 M5364	E0215R E0216R E0217R	D2101Q	H2203R	P2765-A P2766-A P2767-A	MH41	MT01	TVX5 #14
C007J-W811A C858J /CRL/RL	248 356 364	M5248 M5356 M5364	E0215Q E0216Q E0217Q	D2101Q	H2203Q	P2765-A P2766-A P2767-A	MH41	MT01	TVX5 #14
C007J-U811 C858J /CRL/RL	248 356 364	M5248 M5356 M5364	E0215R E0216R E0217R	D2101Q	H2203R	P0965-A P0966-A P0967-A	—	MT01	TVX5 #14
C007J-U811A C858J /CRL/RL	248 356 364	M5248 M5356 M5364	E0215Q E0216Q E0217Q	D2101Q	H2203Q	P0965-A P0966-A P0967-A	—	MT01	TVX5 #14
C007J-W811 C858J CRL/UTP/RL	248 356 364	M5248 M5356 M5364	E0215R E0216R E0217R	D2101Q	H2203R	P2765-A P2766-A P2767-A	MH41	MT01	TVX5 #14
C007J-W811A C858J CRL/UTP/RL	248 356 364	M5248 M5356 M5364	E0215Q E0216Q E0217Q	D2101Q	H2203Q	P2765-A P2766-A P2767-A	MH41	MT01	TVX5 #14
C007J-U811 C858J CRL/UTQ/RL	248 356 364	M5248 M5356 M5364	E0215R E0216R E0217R	D2101Q	H2203R	P0965-A P0966-A P0967-A	—	MT01	TVX5 #14
C007J-U811A C858J CRL/UTQ/RL	248 356 364	M5248 M5356 M5364	E0215Q E0216Q E0217Q	D2101Q	H2203Q	P0965-A P0966-A P0967-A	—	MT01	TVX5 #14
C007J-W812 C858J /CRL/RL	232 248 356 364	M5232 M5248 M5356 M5364	E0223R E0225R E0226R E0227R	D2101Q	H2203R	P2763-A P2765-A P2766-A P2767-A	MH41	MT01	UYX128GAS #10
C007J-W812A C858J /CRL/RL	248 356 364	M5248 M5356 M5364	E0225Q E0226Q E0227Q	D2101Q	H2203Q	P2765-A P2766-A P2767-A	MH41	MT01	UYX128GAS #10
C007J-U812 C858J /CRL/RL	248 356 364	M5248 M5356 M5364	E0225R E0226R E0227R	D2101Q	H2203R	P0965-A P0966-A P0967-A	—	MT01	UYX128GAS #10
C007J-U812A C858J /CRL/RL	248 356 364	M5248 M5356 M5364	E0225Q E0226Q E0227Q	D2101Q	H2203Q	P0965-A P0966-A P0967-A	—	MT01	UYX128GAS #10







註：C007J-W812A/W813A 機型之針板與差送具為5排齒。
C858J

The needle plate and the differential feed dog of W812A/W813A model are five teeth.

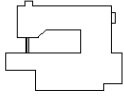
C007J-W812/W813 機型之針板與差送具為4排齒。
C858J

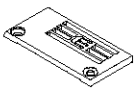
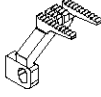
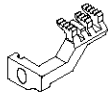
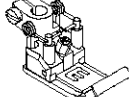
The needle plate and the differential feed dog of W812/W813 model are four teeth.

筒車規格件表 / CONVERSION CHART

									
MODEL	SUB-CLASS	NEEDLE CLAMP	NEEDLE PLATE	MAIN FEED DOG	DIFF. FEED DOG	PRESSER FOOT	SPREADER	LOOPER	NEEDLE
機 型	規 格	針 座	針 板	主 送 具	差 送 具	押 具	上 叉	勾 針	針 號
C007J-W812 C858J CRL/UTP/RL	248 356 364	M5248 M5356 M5364	E0225R E0226R E0227R	D2101Q	H2203R	P2765-A P2766-A P2767-A	MH41	MT01	UYX128GAS #10
C007J-W812A C858J CRL/UTP/RL	248 356 364	M5248 M5356 M5364	E0225Q E0226Q E0227Q	D2101Q	H2203Q	P2765-A P2766-A P2767-A	MH41	MT01	UYX128GAS #10
C007J-U812 C858J CRL/UTQ/RL	248 356 364	M5248 M5356 M5364	E0225R E0226R E0227R	D2101Q	H2203R	P0965-A P0966-A P0967-A	—	MT01	UYX128GAS #10
C007J-U812A C858J CRL/UTQ/RL	248 356 364	M5248 M5356 M5364	E0225Q E0226Q E0227Q	D2101Q	H2203Q	P0965-A P0966-A P0967-A	—	MT01	UYX128GAS #10
C007J-W812 C858J /CRL/UTR	248 356 364	M5248 M5356 M5364	E0225R E0226R E0227R	D2101Q	H2203R	P2765-A P2766-A P2767-A	MH41	MT01	UYX128GAS #10
C007J-W812A C858J /CRL/UTR	248 356 364	M5248 M5356 M5364	E0225Q E0226Q E0227Q	D2101Q	H2203Q	P2765-A P2766-A P2767-A	MH41	MT01	UYX128GAS #10
C007J-U812 C858J /CRL/UTS	248 356 364	M5248 M5356 M5364	E0225R E0226R E0227R	D2101Q	H2203R	P0965-A P0966-A P0967-A	MH41	MT01	UYX128GAS #10
C007J-U812A C858J /CRL/UTS	248 356 364	M5248 M5356 M5364	E0225Q E0226Q E0227Q	D2101Q	H2203Q	P0965-A P0966-A P0967-A	MH41	MT01	UYX128GAS #10
C007J-W813 C858J /CRL/RL	248 356 364	M5248 M5356 M5364	E0235R E0236R E0237R	D2101Q	H2203R	P2765-A P2766-A P2767-A	MH41	MT01	UYX128GAS #10
C007J-W813A C858J /CRL/RL	248 356 364	M5248 M5356 M5364	E0235Q E0236Q E0237Q	D2101Q	H2203Q	P2765-A P2766-A P2767-A	MH41	MT01	UYX128GAS #10
C007J-U813 C858J /CRL/RL	248 356 364	M5248 M5356 M5364	E0235R E0236R E0237R	D2101Q	H2203R	P0965-A P0966-A P0967-A	—	MT01	UYX128GAS #10
C007J-U813A C858J /CRL/RL	248 356 364	M5248 M5356 M5364	E0235Q E0236Q E0237Q	D2101Q	H2203Q	P0965-A P0966-A P0967-A	—	MT01	UYX128GAS #10

註：C007J-W812A/W813A機型之針板與差送具為5排齒。
C858J

The needle plate and the differential feed dog of W812A/W813A model are five teeth.

C007J-W812/W813 機型之針板與差送具為4排齒。
C858J

The needle plate and the differential feed dog of W812/W813 model are four teeth.

筒車規格件表 / CONVERSION CHART

									
MODEL	SUB-CLASS	NEEDLE CLAMP	NEEDLE PLATE	MAIN FEED DOG	DIFF. FEED DOG	PRESSER FOOT	SPREADER	LOOPER	NEEDLE
機 型	規 格	針 座	針 板	主 送 具	差 送 具	押 具	上 叉	勾 針	針 號
C007J-W813 C858J /CRL/UTR	248 356 364	M5248 M5356 M5364	E0235R E0236R E0237R	D2101Q	H2203R	P2765-A P2766-A P2767-A	MH41	MT01	TVX5 #14
C007J-W813A C858J /CRL/UTR	248 356 364	M5248 M5356 M5364	E0235Q E0236Q E0237Q	D2101Q	H2203Q	P2765-A P2766-A P2767-A	MH41	MT01	TVX5 #14
C007J-U813 C858J /CRL/UTS	248 356 364	M5248 M5356 M5364	E0235R E0236R E0237R	D2101Q	H2203R	P0965-A P0966-A P0967-A	MH41	MT01	TVX5 #14
C007J-U813A C858J /CRL/UTS	248 356 364	M5248 M5356 M5364	E0235Q E0236Q E0237Q	D2101Q	H2203Q	P0965-A P0966-A P0967-A	MH41	MT01	TVX5 #14
C007J-W822 C858J /CRL/CY/CL/RL	248 356 364	M5248 M5356 M5364	E0225R E0226R E0227R	D2101Q	H2203R	P2765-A P2766-A P2767-A	MH41	MT01	UYX128GAS #10
C007J-W823 C858J /CRL/CY/CL/RL	248 356 364	M5248 M5356 M5364	E0235R E0236R E0237R	D2101Q	H2203R	P2765-A P2766-A P2767-A	MH41	MT01	TVX5 #14
C007J-U822 C858J /CRL/CY/CL/RL	248 356 364	M5248 M5356 M5364	E0225R E0226R E0227R	D2101Q	H2203R	P0965-A P0966-A P0967-A	—	MT01	UYX128GAS #10
C007J-U823 C858J /CRL/CY/CL/RL	248 356 364	M5248 M5356 M5364	E0235R E0236R E0237R	D2101Q	H2203R	P0965-A P0966-A P0967-A	—	MT01	TVX5 #14
C007J-W822 C858J CRL/CY/UTP/CL/RL	248 356 364	M5248 M5356 M5364	E0225R E0226R E0227R	D2101Q	H2203R	P2765-A P2766-A P2767-A	MH41	MT01	UYX128GAS #10
C007J-W823 C858J CRL/CY/UTP/CL/RL	248 356 364	M5248 M5356 M5364	E0235R E0236R E0237R	D2101Q	H2203R	P2765-A P2766-A P2767-A	MH41	MT01	TVX5 #14

註：C007J-W812A/W813A機型之針板與差送具為5排齒。
C858J







The needle plate and the differential feed dog of W812A/W813A model are five teeth.

C007J-W812/W813 機型之針板與差送具為4排齒。
C858J

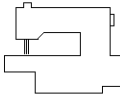
The needle plate and the differential feed dog of W812/W813 model are four teeth.

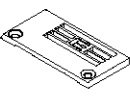
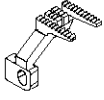
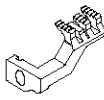
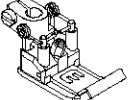
筒車規格件表/CONVERSION CHART

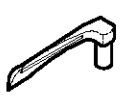
P10

									
MODEL	SUB-CLASS	NEEDLE CLAMP	NEEDLE PLATE	MAIN FEED DOG	DIFF. FEED DOG	PRESSER FOOT	SPREADER	LOOPER	NEEDLE
機 型	規 格	針 座	針 板	主 送 具	差 送 具	押 具	上 叉	勾 針	針 號
C007J-U822 C858J CRL/CY/UTQ/CL/RL	248 356 364	M5248 M5356 M5364	E0225R E0226R E0227R	D2101Q	H2203R	P0965-A P0966-A P0967-A	—	MT01	UYX128GAS #10
C007J-U823 C858J CRL/CY/UTQ/CL/RL	248 356 364	M5248 M5356 M5364	E0235R E0236R E0237R	D2101Q	H2203R	P0965-A P0966-A P0967-A	—	MT01	TVX5 #14
C007J-U822 C858J CRL/CY/UTQ/CL/RL	248 356 364	M5248 M5356 M5364	E0225R E0226R E0227R	D2101Q	H2203R	P0965-A P0966-A P0967-A	—	MT01	UYX128GAS #10
C007J-U823 C858J CRL/CY/UTQ/CL/RL	248 356 364	M5248 M5356 M5364	E0235R E0236R E0237R	D2101Q	H2203R	P0965-A P0966-A P0967-A	—	MT01	TVX5 #14

09/12/11

筒車規格件表/CONVERSION CHART

										
MODEL	SUB-CLASS	NEEDLE CLAMP	NEEDLE PLATE	MAIN FEED DOG	DIFF. FEED DOG	PRESSER FOOT	SPREADER	LOOPER	CAM	NEEDLE
機 型	規 格	針 座	針 板	主 送 具	差 送 具	押 具	上 叉	勾 針	偏 心 凸 輪	針 號
C007J-W522 C858J /FE(FFC)/CRA/CL	356 364	M5356 M5364	E 6426P E 6427P	D 3222	H 3268	P3116 P3117	MH41E	MT01	MF01-A	UYX128GAS #11
C007J-U522 C858J /FE(FFC)/CRA/CL	356 364	M5356 M5364	E 6426P E 6427P	D 3222	H 3268	P3116 P3117	—	MT01	MF01-A	UYX128GAS #11
C007J-W522 C858J /FE(FFC)/CRB/CL	356 364	M5356 M5364	E 6426P E 6427P	D 3222	H 3268	P3116 P3117	MH41E	MT01	MF01-A	UYX128GAS #11
C007J-U522 C858J /FE(FFC)/CRB/CL	356 364	M5356 M5364	E 6426P E 6427P	D 3222	H 3268	P3116 P3117	—	MT01	MF01-A	UYX128GAS #11
C007J-W532/ C858J CRA/UTP/CL/RLP/CX-A	356 364	M5356 M5364	E 6426P E 6427P	D 3222	H 3268	P3816Q P3817Q	MH41E	MT01	MF01-A	UYX128GAS #11
C007J-U532/ C858J CRA/UTQ/CL/RLP/CX-A	356 364	M5356 M5364	E 6426P E 6427P	D 3222	H 3268	P3816Q P3817Q	—	MT01	MF01-A	UYX128GAS #11
C007J-W532/ C858J CRA/UTP/CL/RLP/CX-B	356 364	M5356 M5364	E 6426P E 6427P	D 3222	H 3268	P3816Q P3817Q	MH41E	MT01	MF01-A	UYX128GAS #11
C007J-U532/ C858J CRA/UTQ/CL/RLP/CX-B	356 364	M5356 M5364	E 6426P E 6427P	D 3222	H 3268	P3816Q P3817Q	MH41E	MT01	MF01-A	UYX128GAS #11

C007J PARTS LIST FOR MF GROUP P.1/1

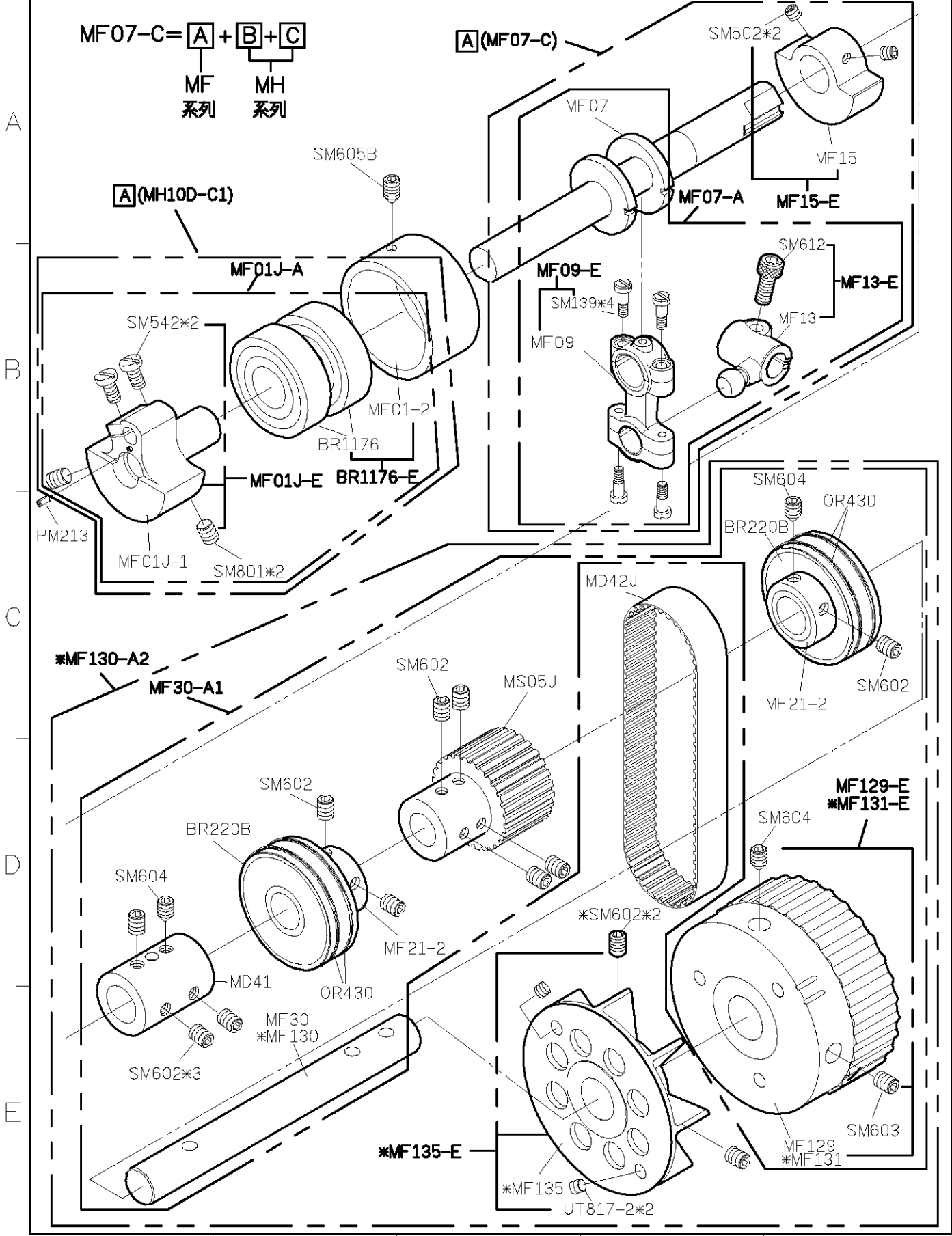

FOR C007J/C007JD/S007K/S007KD
 *USE FOR C007JD/S007KD

11/08/29

C007J PARTS LIST FOR MG GROUP P.1/1

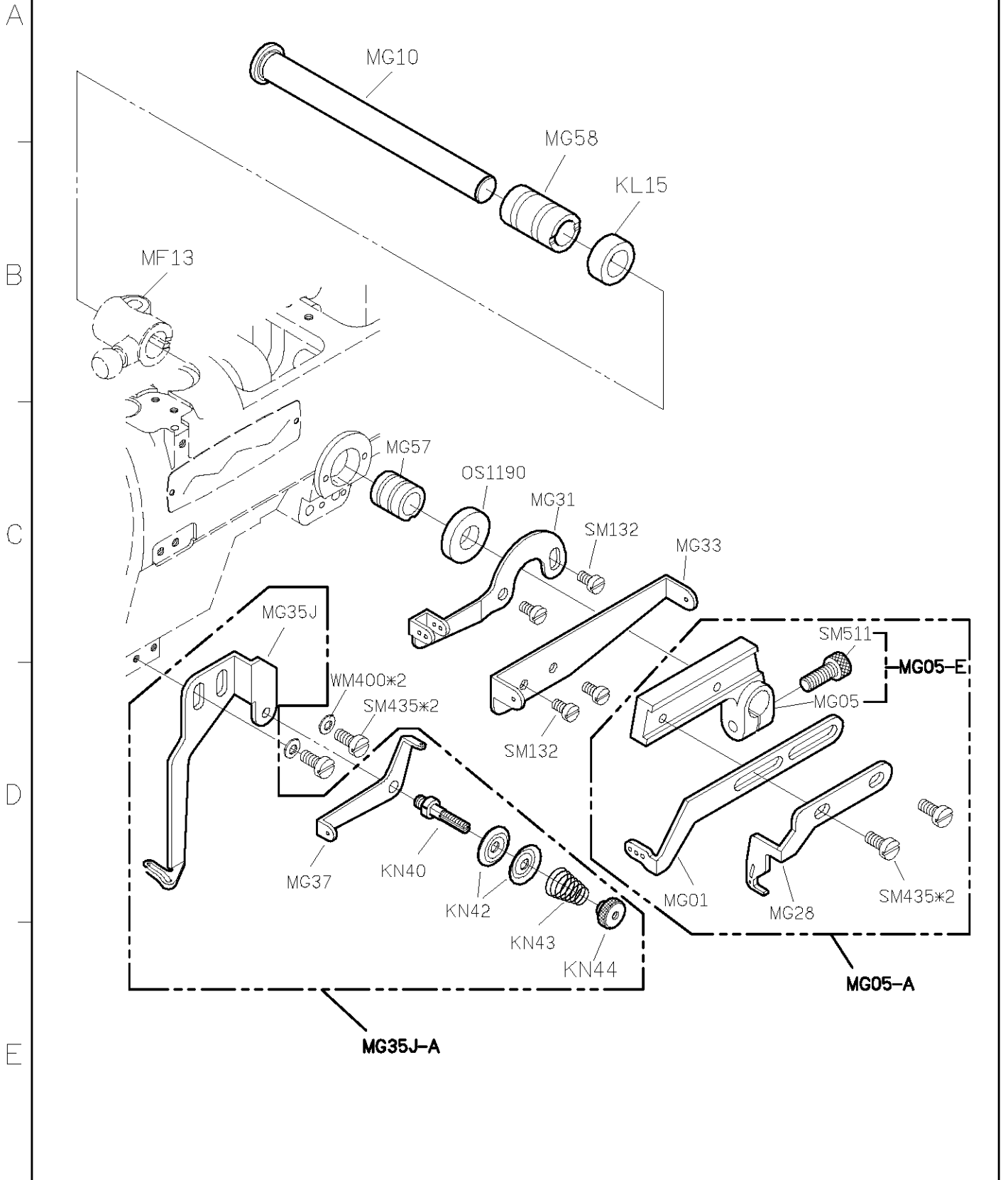

FOR C007J/C007JD/S007K/S007KD

11/09/24

C007J PARTS LIST FOR MH GROUP P.1/1

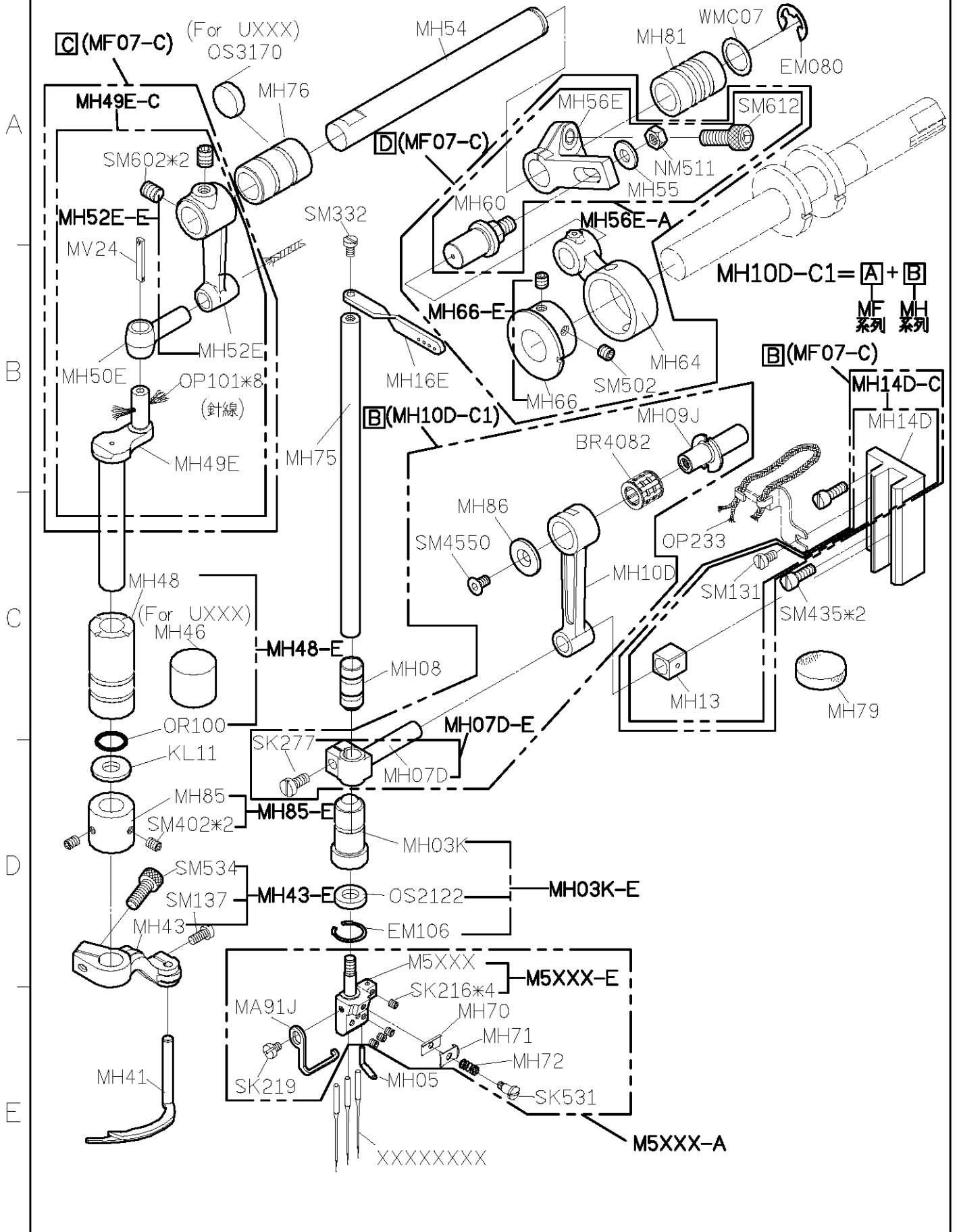

FOR C007J/C007JD/S007K/S007KD

12/03/15

C007J PARTS LIST FOR MJ GROUP P.1/1

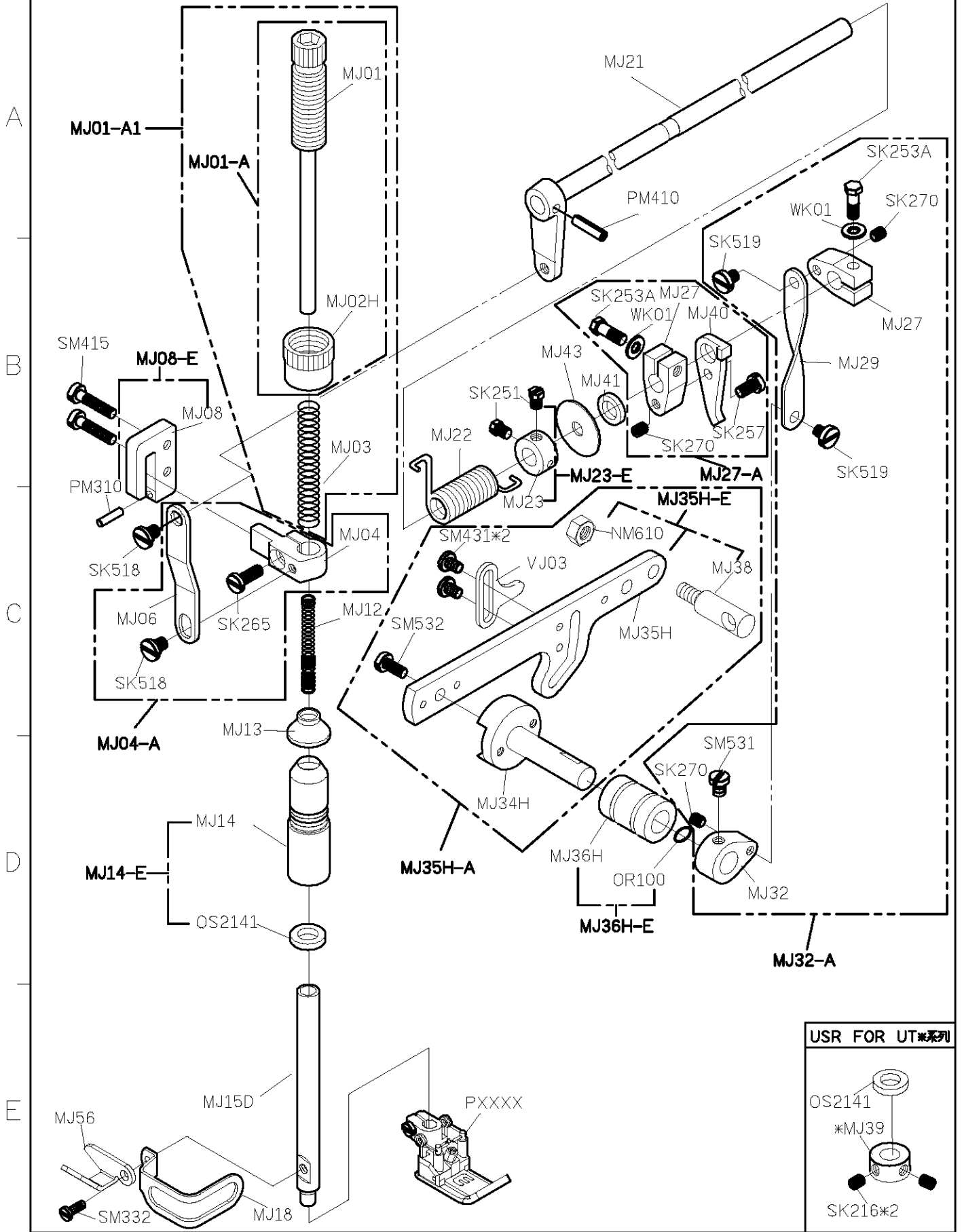

FOR C007J/C007JD/S007K/S007KD

11/06/07

C007J PARTS LIST FOR MK GROUP P.1/1

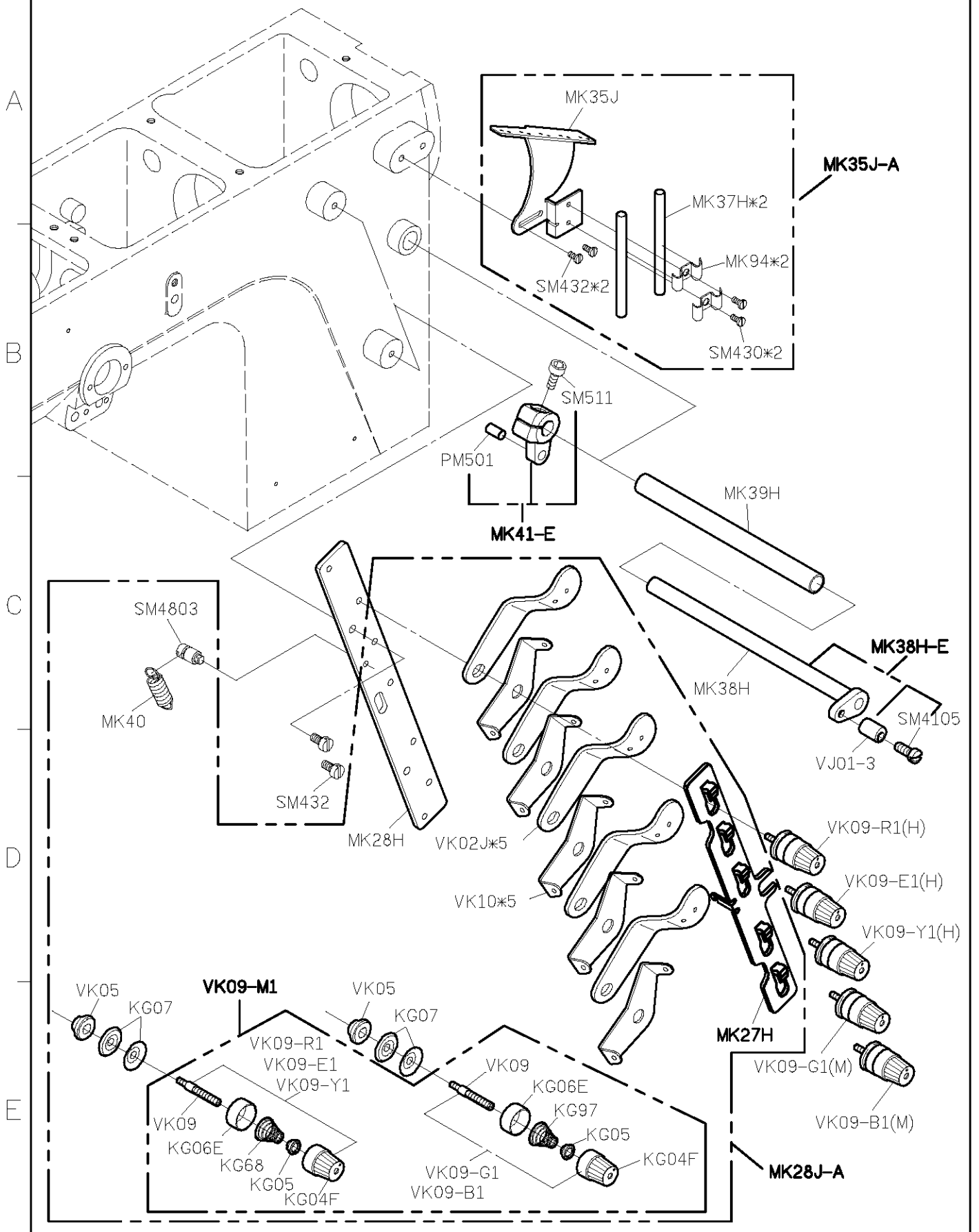

FOR C007J/C007JD/F007J/F007JD/S007K/KD

11/08/12

PARTS LIST FOR MN GROUP P.1/2

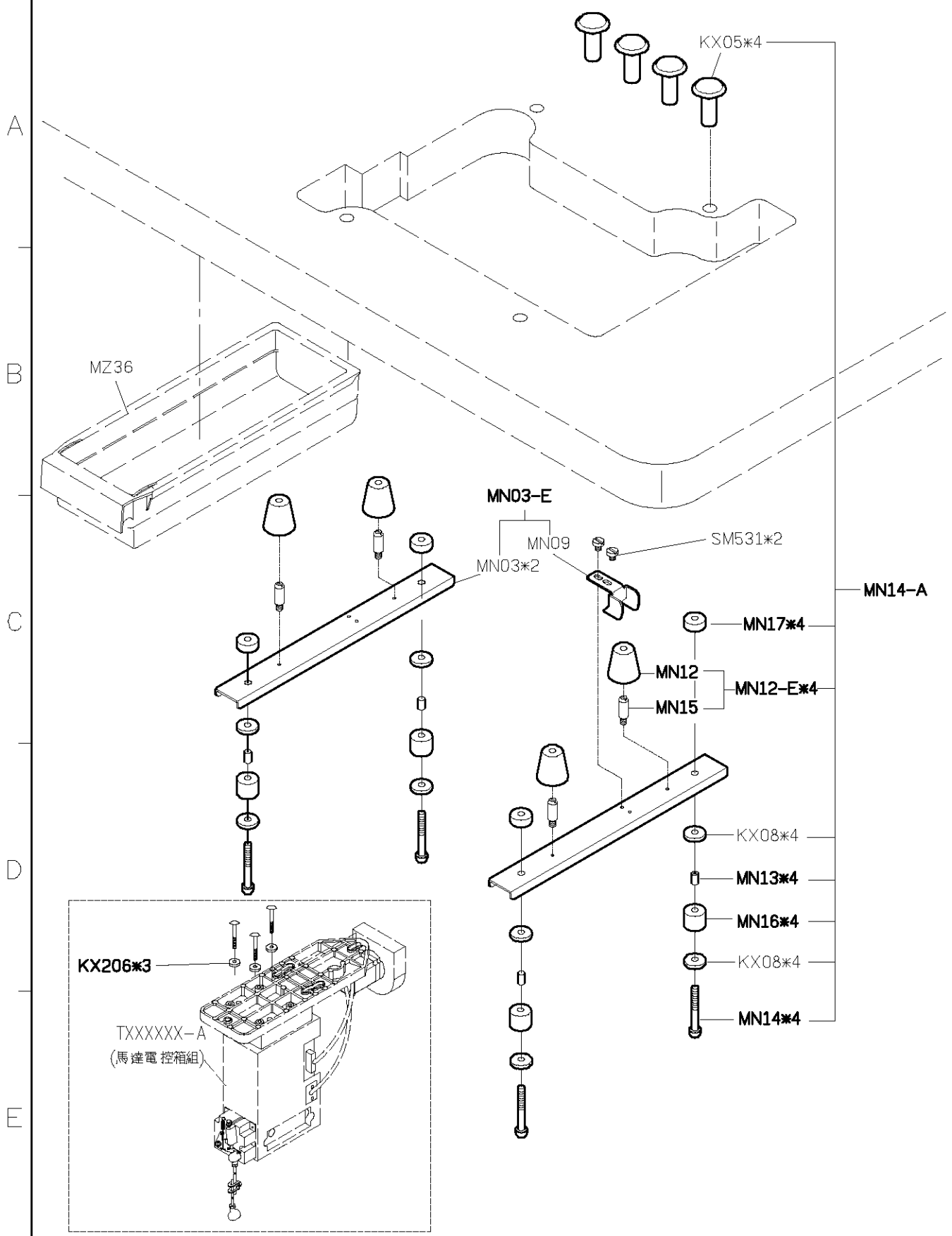

PARTS LIST FOR MN GROUP P.2/2

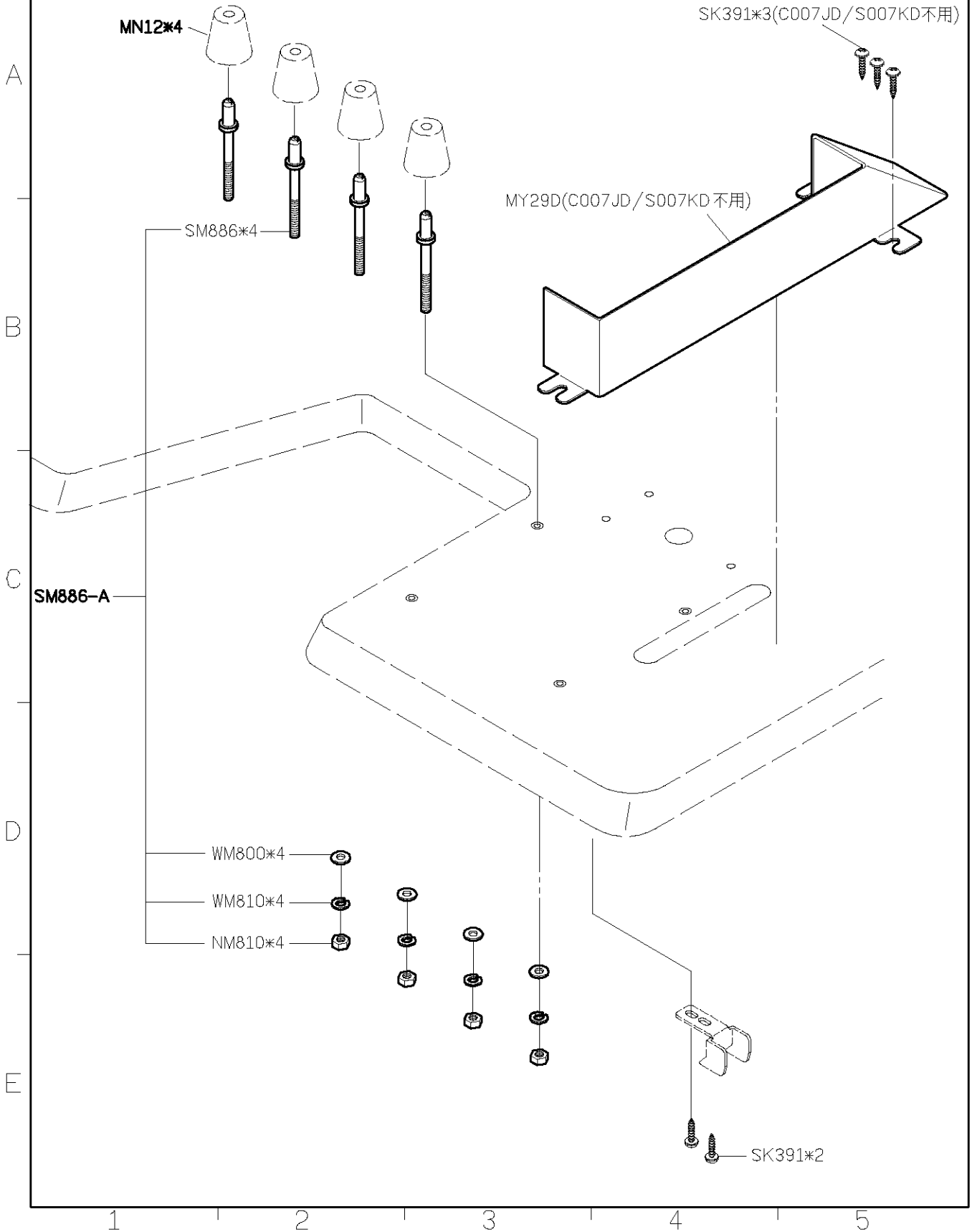

FOR C007J/C007JD/C858J/C858JD/S007K/S007KD

12/04/06

C007J PARTS LIST FOR MQ-J GROUP P.1/1

選配件

PARTS NO. MQ42

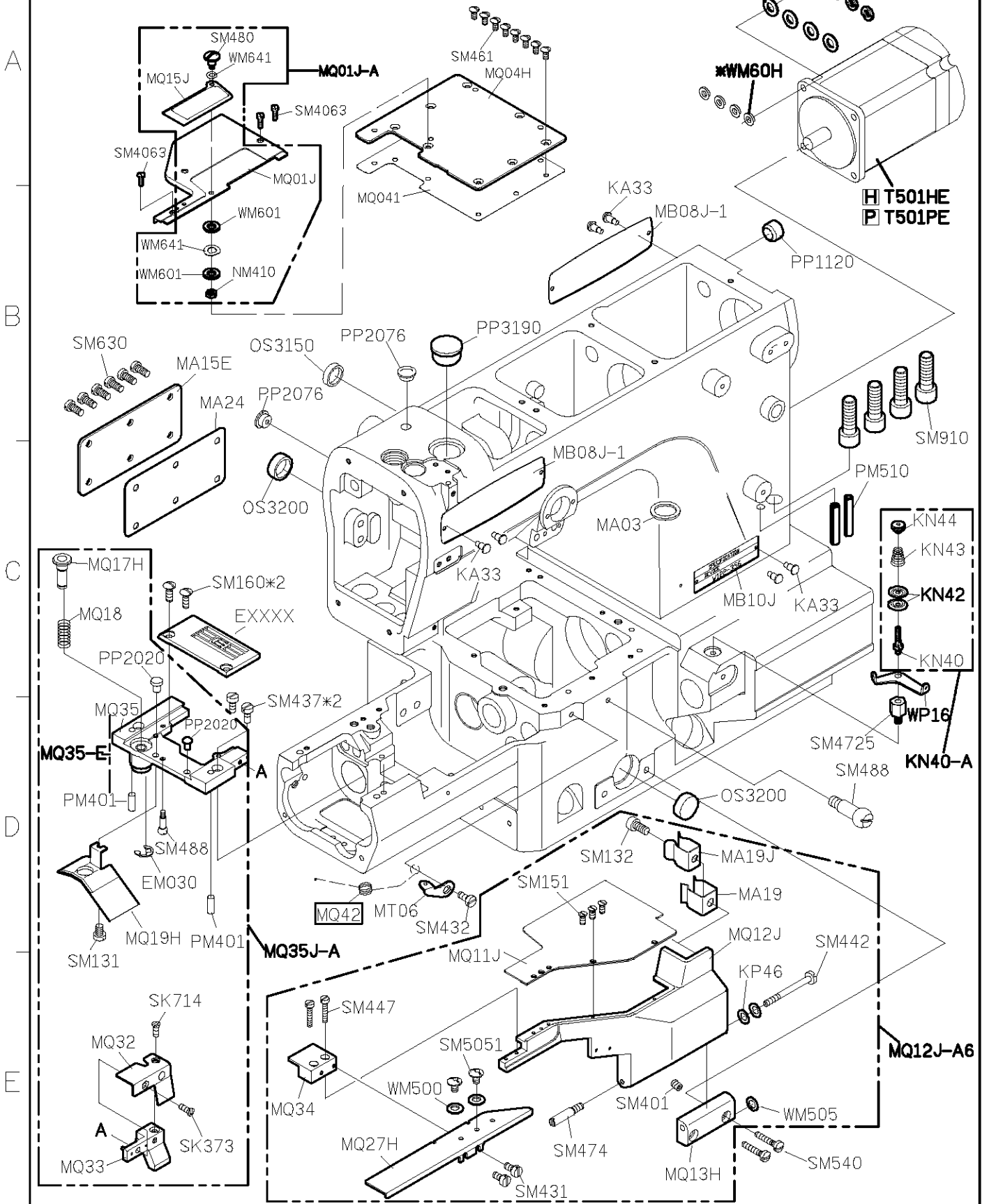

FOR C007J/C007JD/C858J/C858JD

FOR C007JD/C858JD

11/03/14

C007J PARTS LIST FOR MR-J GROUP P.1/1

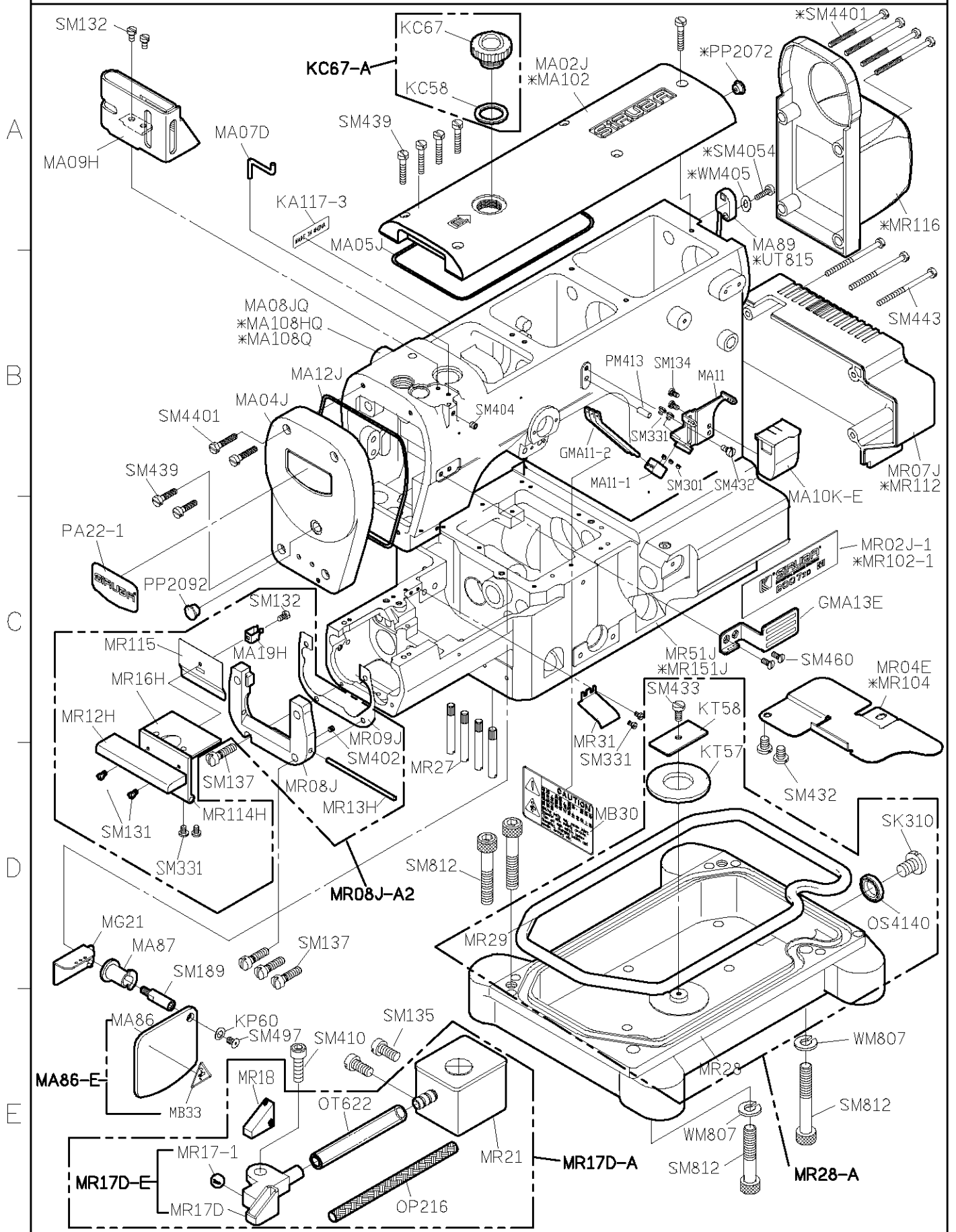

FOR C007J/C007JD/C858J/C858JD
 *USE FOR C007JD/C858JD

11/08/09

C007J PARTS LIST FOR MS GROUP P.1/1

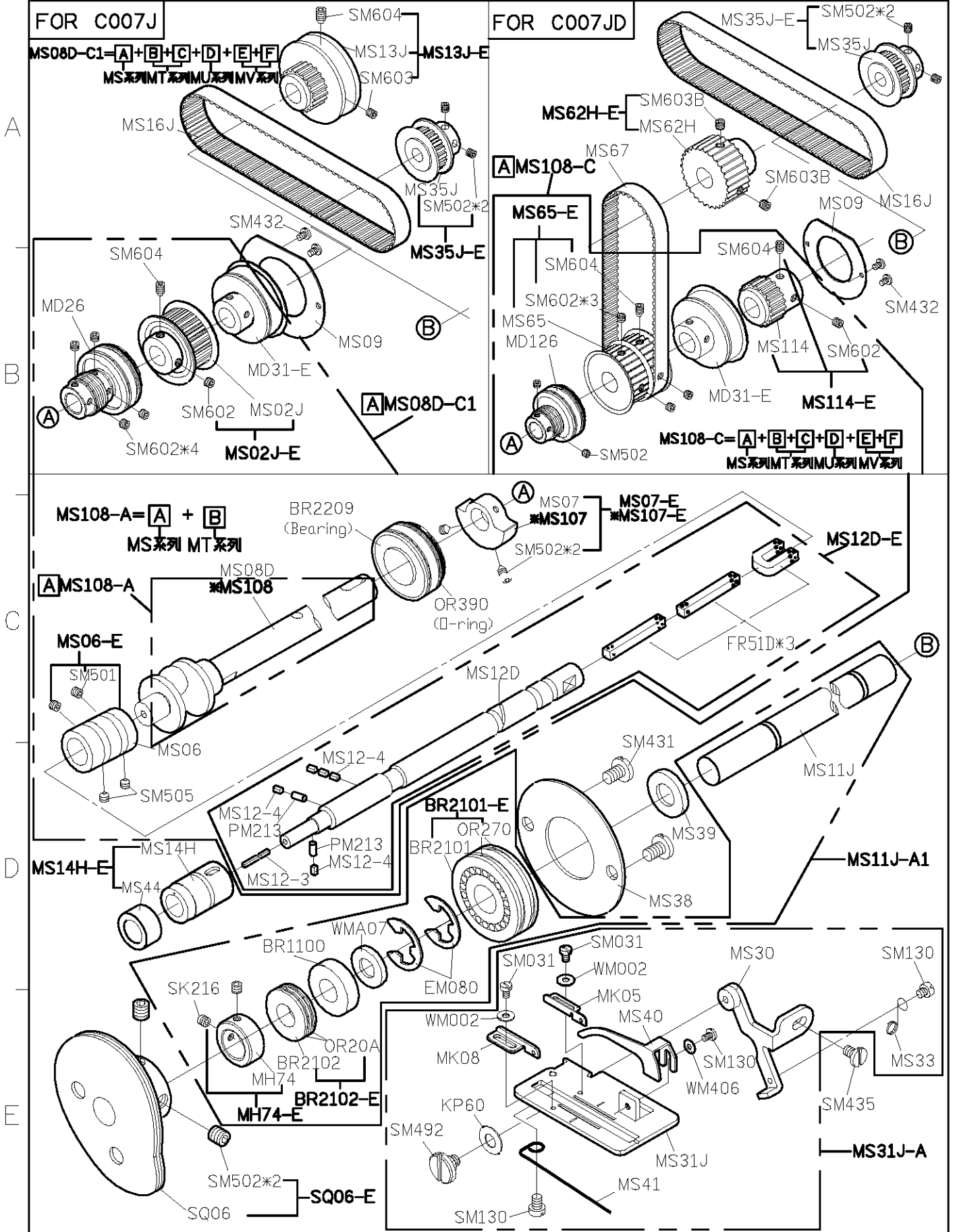

PARTS LIST FOR MT GROUP P.1/1

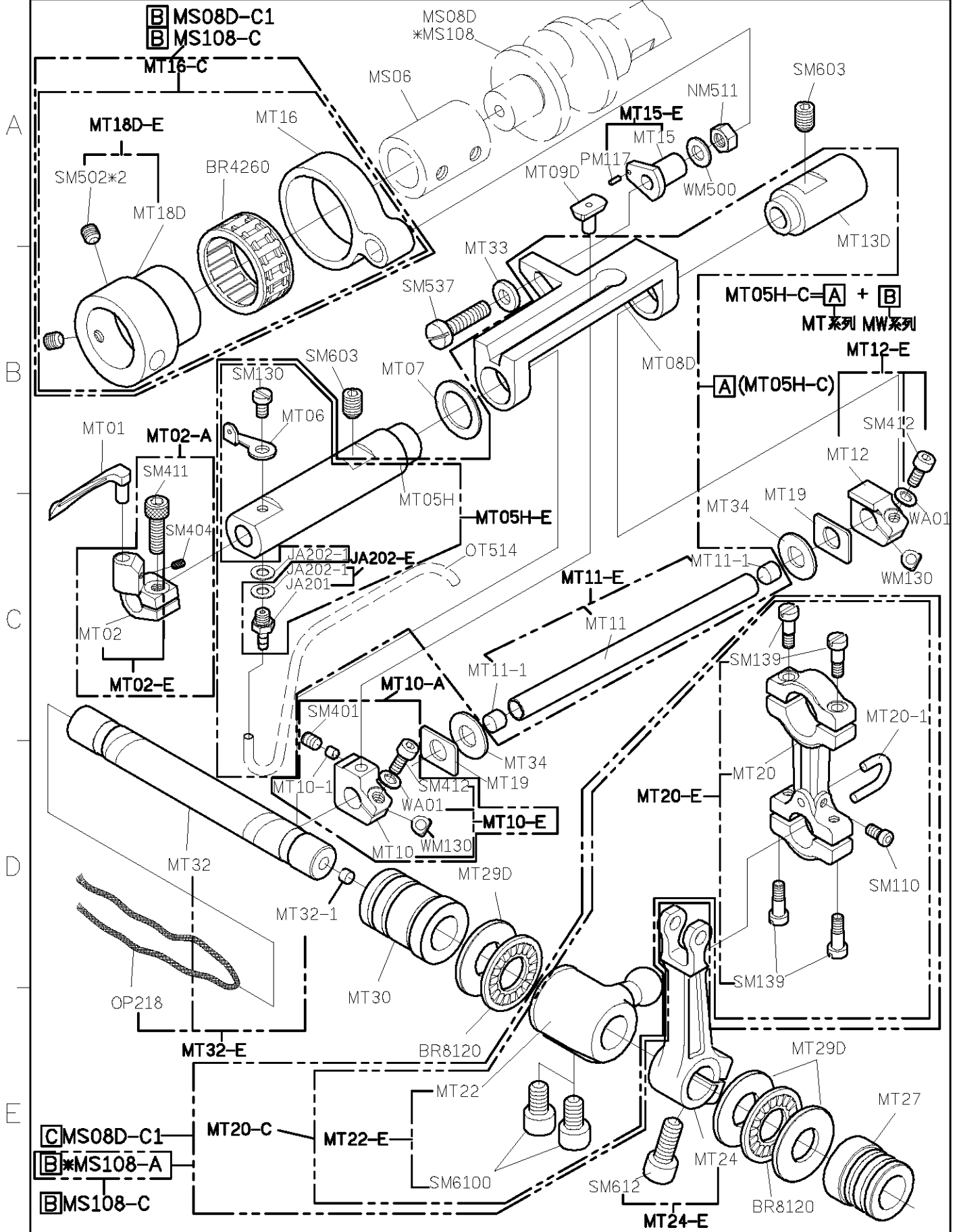

FOR C007J/C007JD/C858J/C858JD
 *USE FOR C007JD/C858JD

11/12/21

C007J PARTS LIST FOR MU GROUP P.1/1

A

B

C

D

E

- D MS08D-C1
- D MS108-C

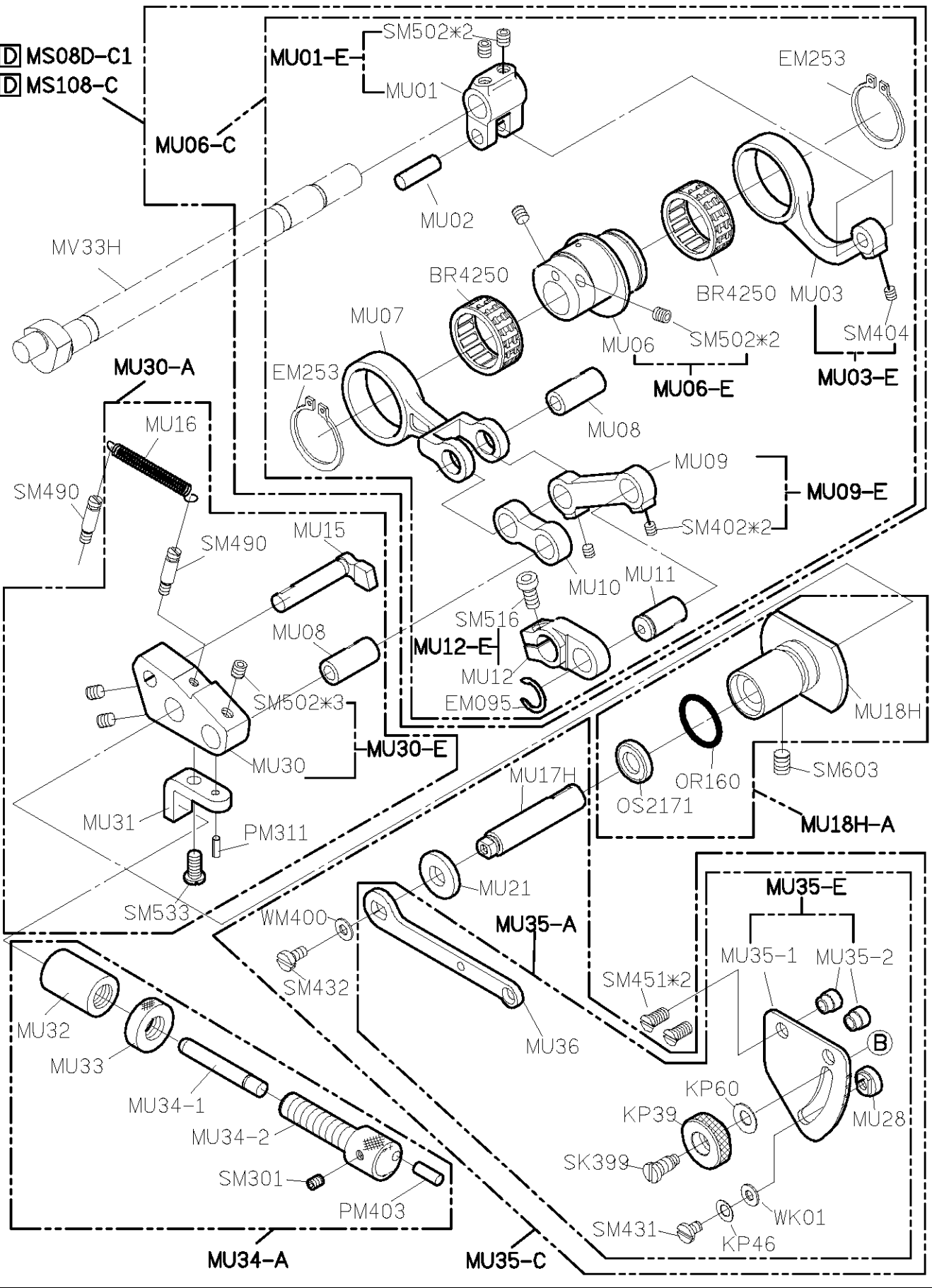

C007J PARTS LIST FOR MV GROUP P.1/1

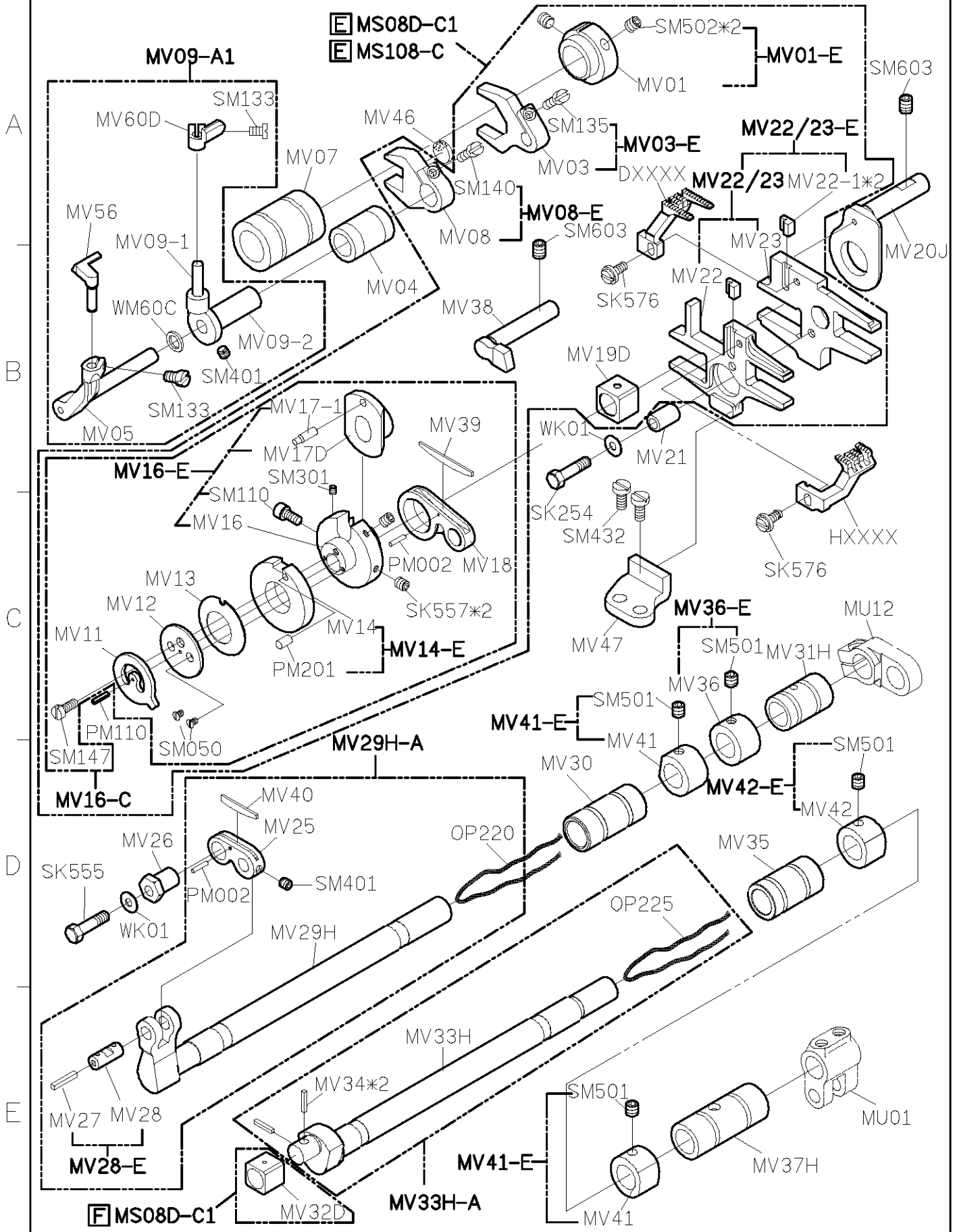

FOR C007J/C007JD/C858J/C858JD

11/09/29

C007J

PARTS LIST

FOR MW

GROUP P.1/1

A

B

C

D

E

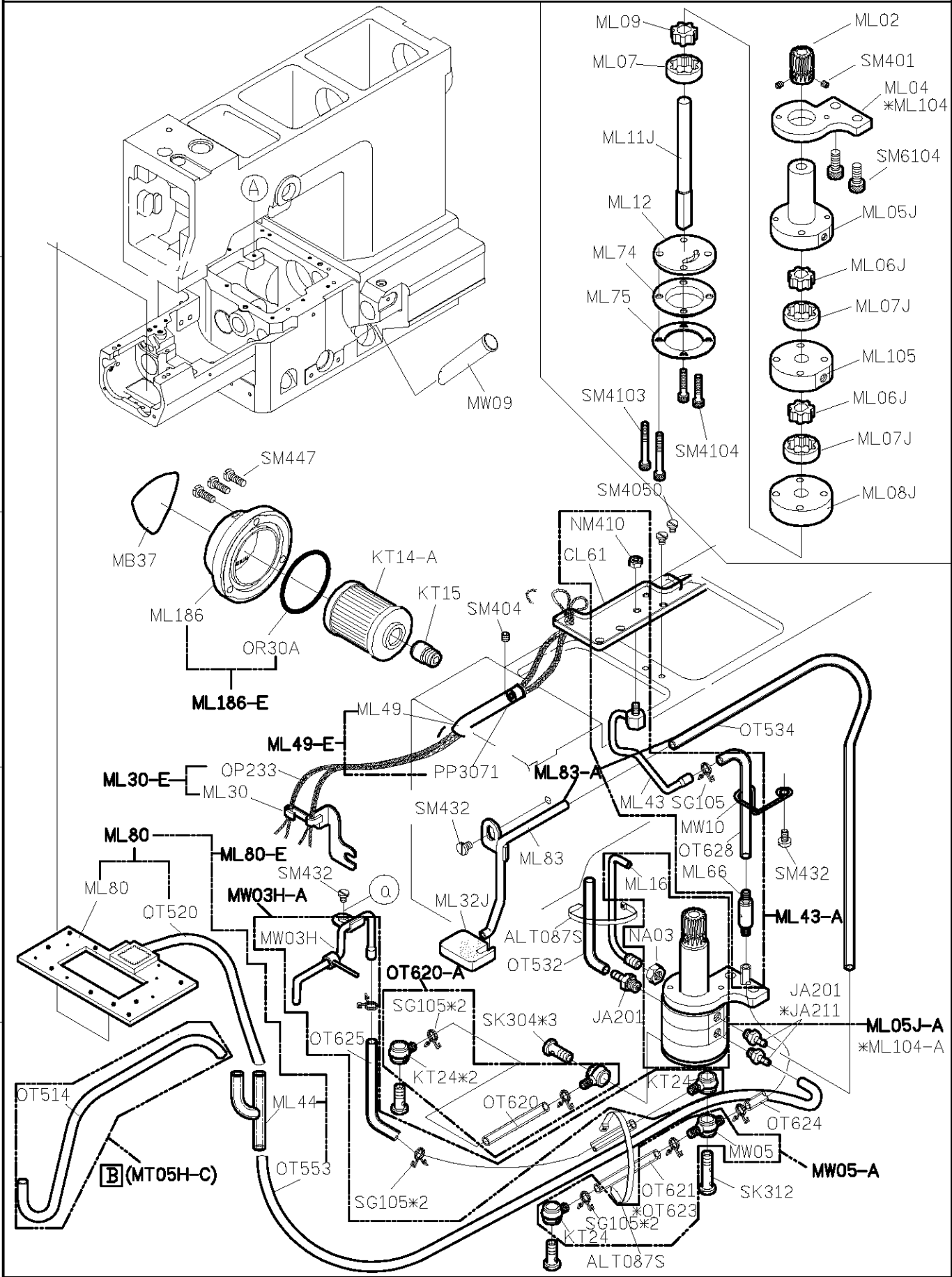

1 2 3 4 5
 FOR C007J/C007JD/C858J/C858JD
 *USE FOR C007JD/C858JD

10/12/16

From the library of: Superior Sewing Machine & Supply LLC

C007J PARTS LIST FOR MY GROUP P.1/1

A

MY01 KY03 KY04 KY05-A KY23-A
 KY23(6/7mm) KY09

B

MY10-A
 MY09 KY10 MY10 MY11 MY12
 KY11 KY14 LY33-A LY33 LY34 KY18

C

KY20D-A 針*5
 KY21-1 MY21 -MY21-E KY201 KZ03*1

D

KT14-A MY29D
 △SM886-A □ SM886-A1
 SM886*4 WM800*4
 WM810*4 NM810*4
 SK391*5 SK391*2

E

MY45 使用説明書
 MY46 零件圖
 MY47 (UT975) (UT976)
 筒車特殊件零件圖

零件圖	
基本車	MY46
特種車	MY46 MY47
UTP/UTQ	MY46 UT975
特種車 + UTP/UTQ	MY46 MY47 UT975
UTR/UTS	MY46 UT976
特種車 + UTR/UTS	MY46 MY47 UT976

PARTS LIST FOR MZ GROUP 系列圖 1

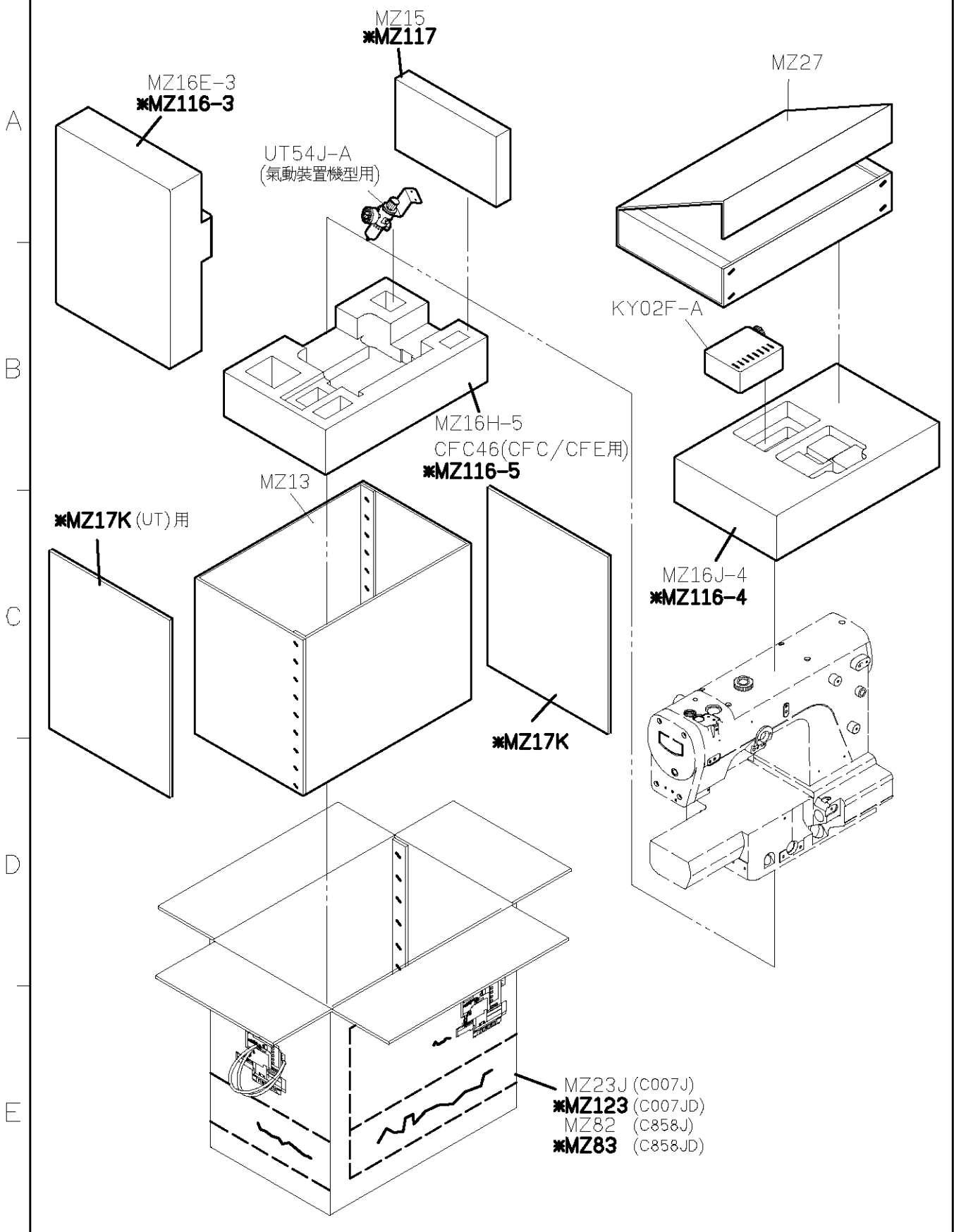

FOR C007J/C858J
 *USE FOR C007JD/C858JD

11/12/23

TABLE CUT-OUT OF C007-T22

三針筒車下乘桌板圖

C007J SERIES TABLE CUT-OUT SEMI-SUBMERGED

單位/UNIT:mm

FOR CRB

所有尺寸公差/DIFFERENCE:±2

C007-T22-1070長度(L):1070/重量:11.5kg±5%

C007-T22長度(L):1200/重量:12.5kg±5%

全封邊灰格紋光塑面台板

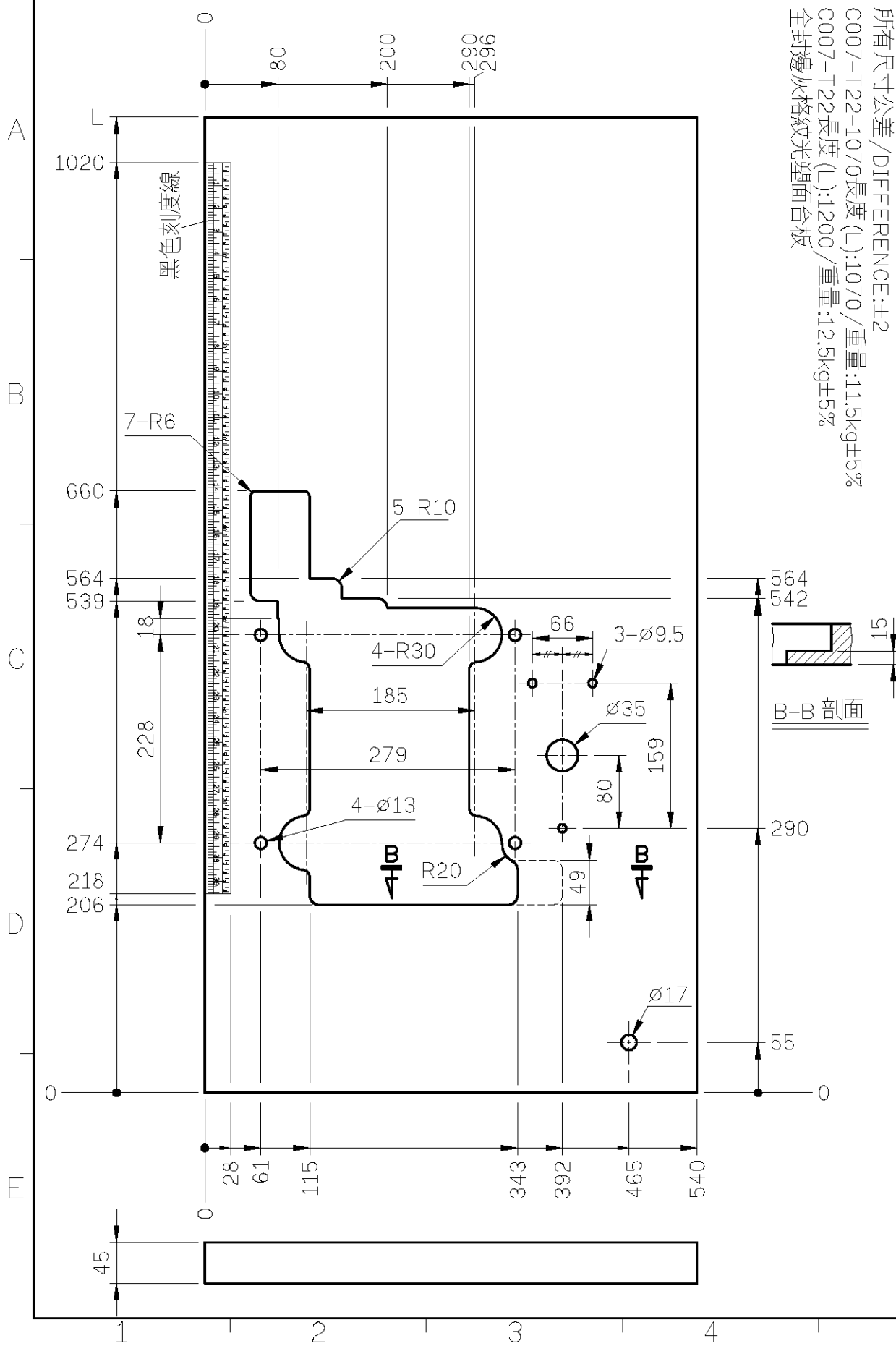

TABLE CUT-OUT OF C007-T23

三針筒車下乘桌板圖

C007K/C007KD/C007J/C007JD/S007K/S007KD SERIES TABLE CUT-OUT SEMI-SUBMERGED

單位/UNIT:mm

FOR一般車及自動切線

所有尺寸公差/DIFFERENCE:±2

C007-T23-1070長度(L):1070/重量:11.5kg±5%

C007-T23長度(L):1200/重量:12.5kg±5%

全封邊灰格紋光塑面台板

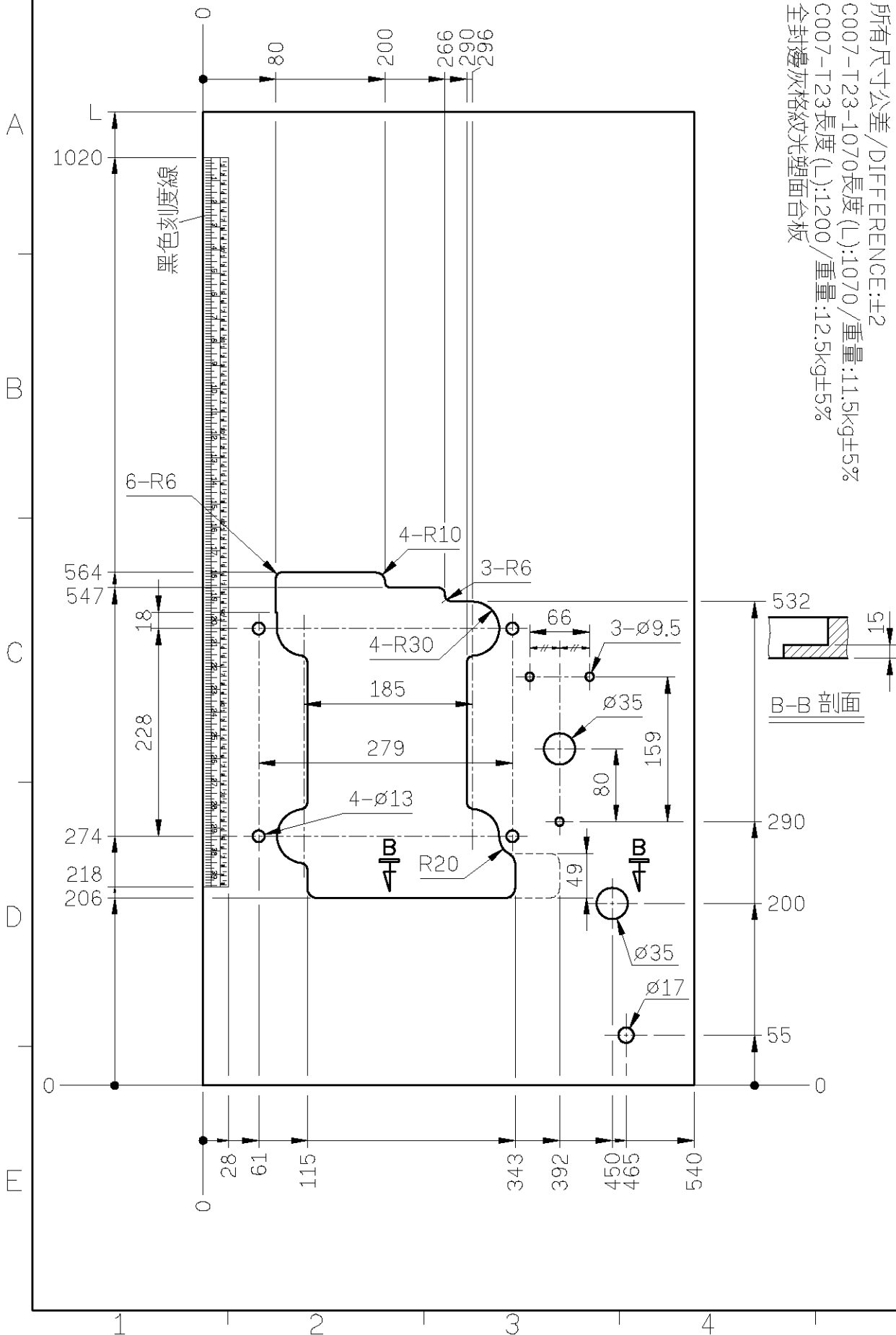

TABLE CUT-OUT OF C007-T24

三針筒車上乘桌板圖

C007J SERIES TABLE CUT-OUT SEMI-SUBMERGED

單位/UNIT:mm

FOR 一般車及自動切線

所有尺寸公差/DIFFERENCE:±2

C007-T24-1070長度(L):1070/重量:11.3kg±5%

C007-T24長度(L):1200/重量:12.3kg±5%

全封邊灰格紋光塑面台板

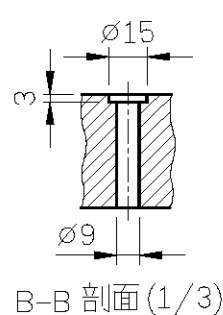
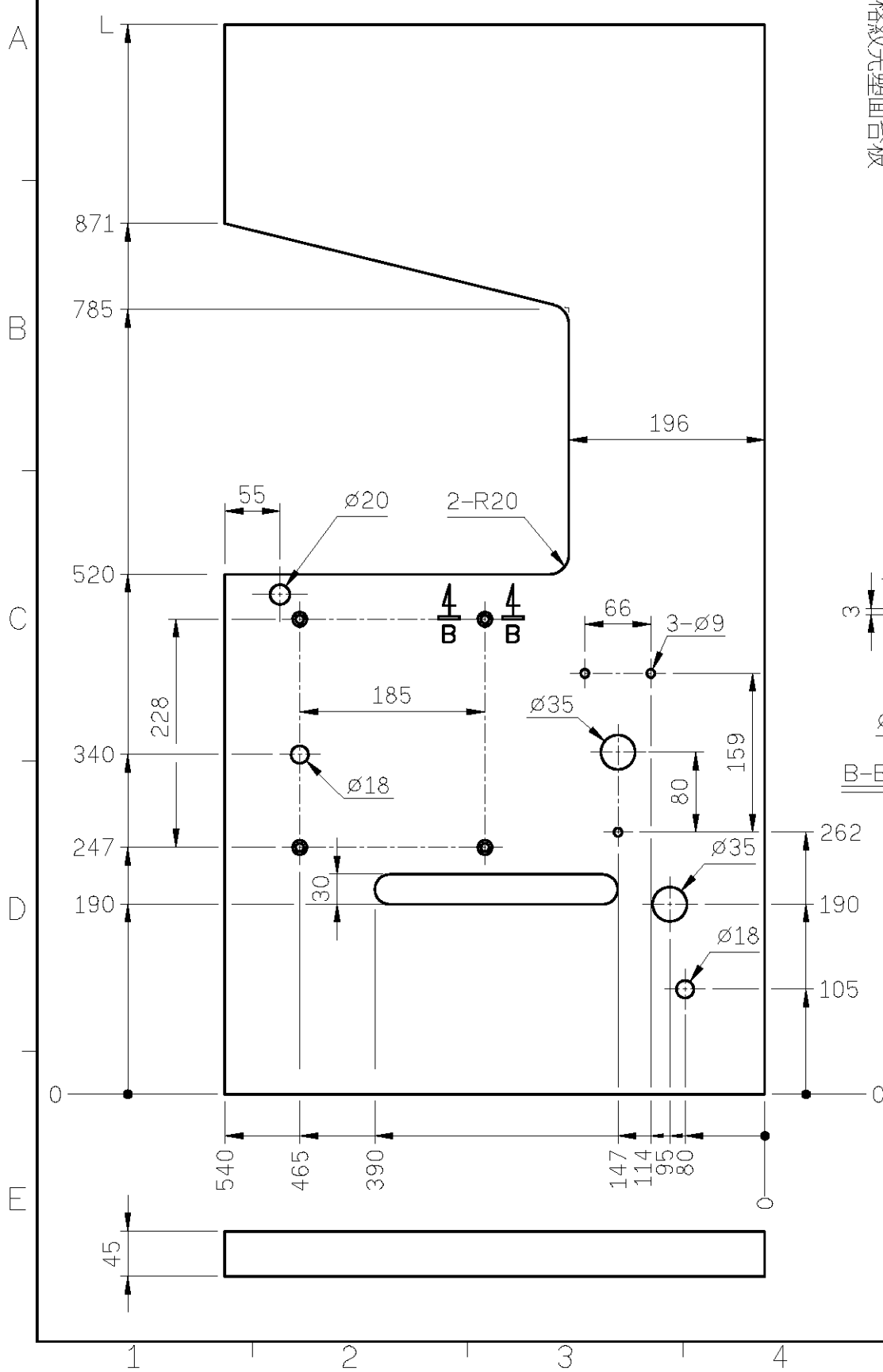

TABLE CUT-OUT OF C007-T25

三針筒車上乘桌板圖

C007J/C007JD/S007K/S007KD SERIES TABLE CUT-OUT SEMI-SUBMERGED

單位/UNIT:mm

FOR CRL/CRL/UTP.Q

所有尺寸公差/DIFFERENCE:±2

C007-T25-1070長度(L):1070/重量:11.3kg±5%

C007-T25長度(L):1200/重量:12.3kg±5%

全封邊灰格紋光塑面台板

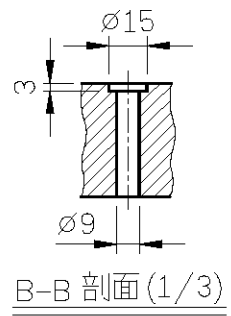
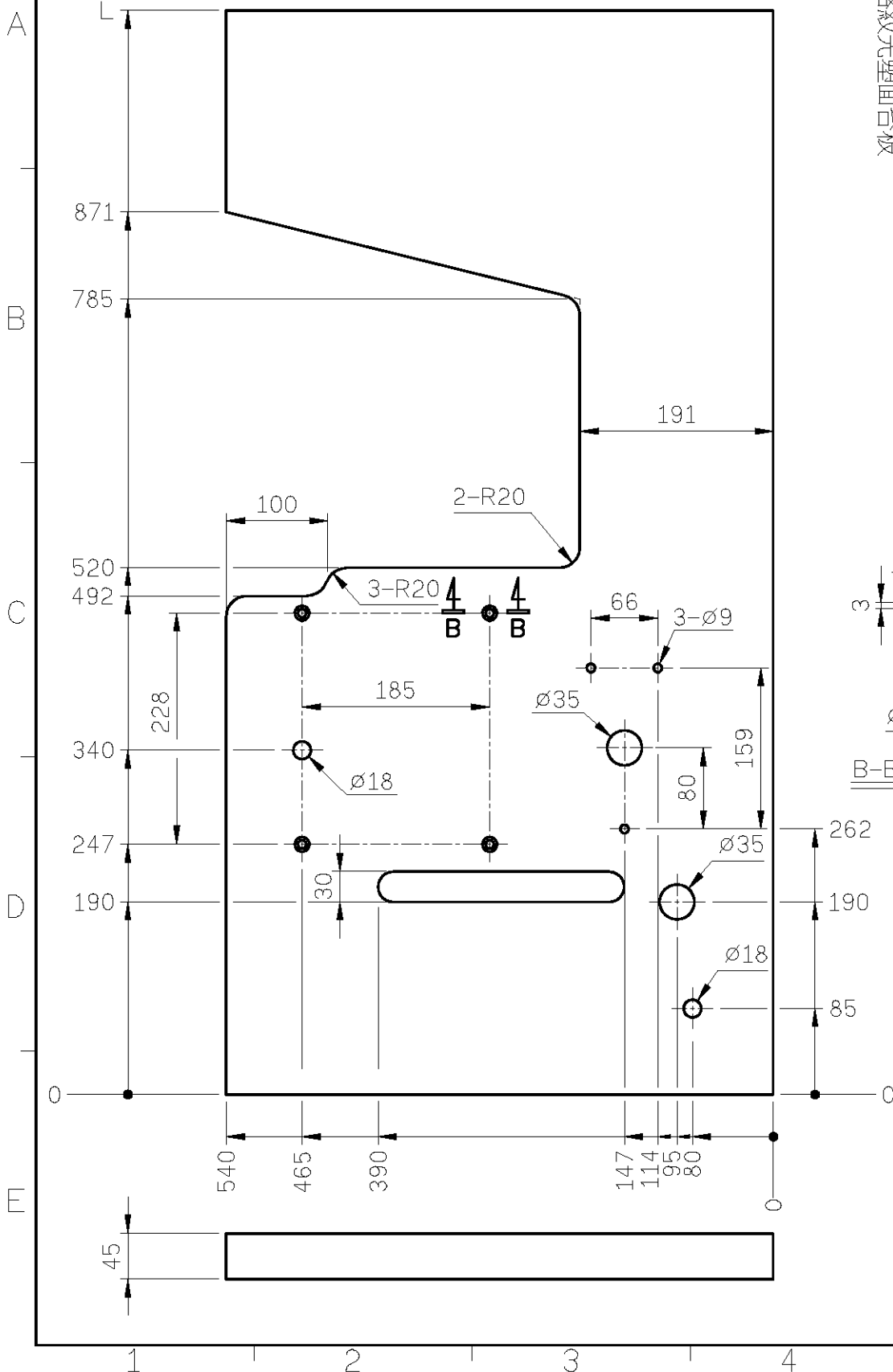

TABLE CUT-OUT OF C007-T26

三針筒車下乘桌板圖

C007J SERIES TABLE CUT-OUT SEMI-SUBMERGED

單位/UNIT:mm

FOR CFC/CFE

所有尺寸公差/DIFFERENCE:±2

C007-T26-1070長度(L):1070/重量:11.4kg±5%

C007-T26長度(L):1200/重量:12.4kg±5%

全封邊灰格紋光塑面台板

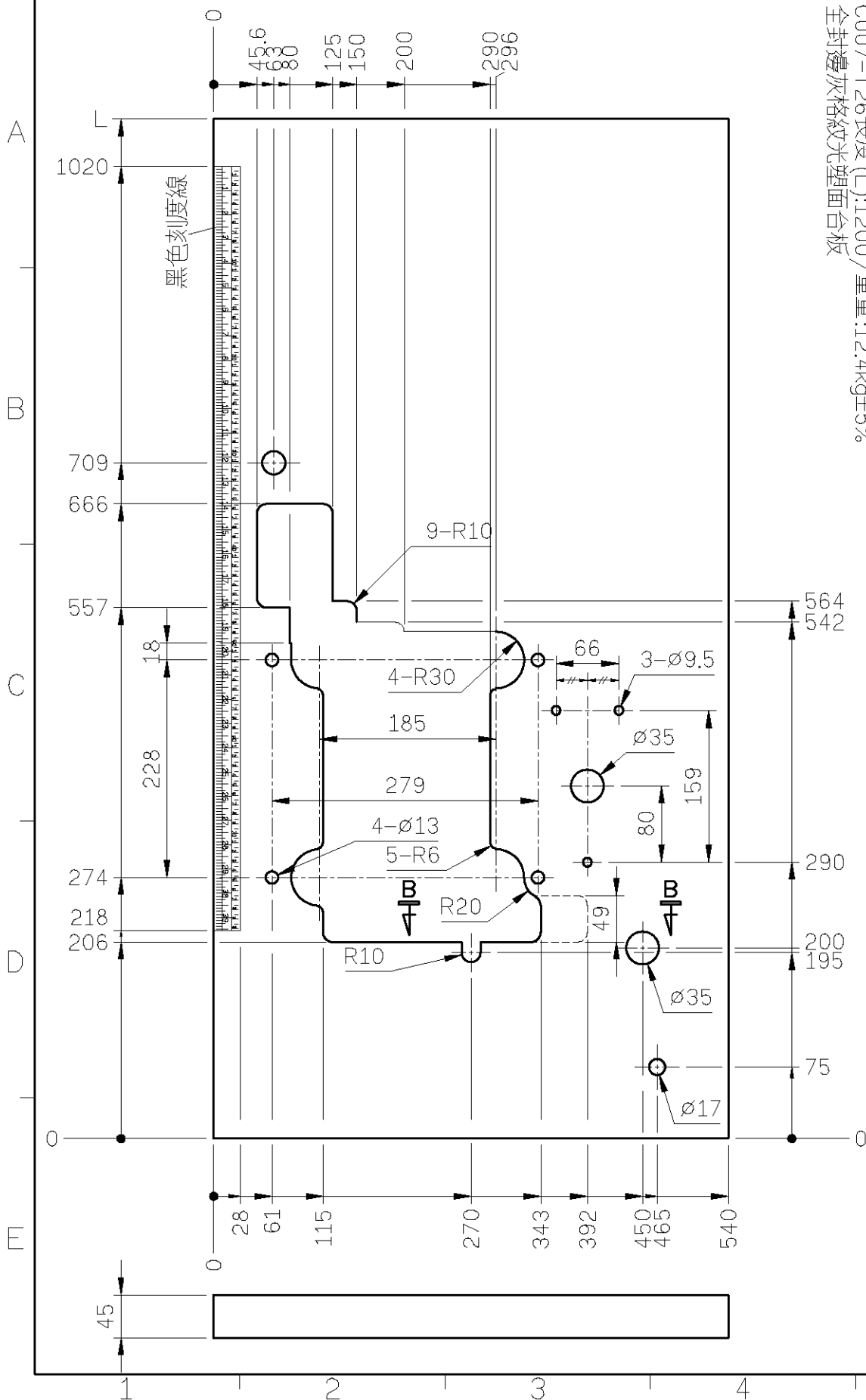

SIRUBA TABLE CUT - OUT	Series	Item Code	Subclass / Remark	Mounting
	C007J/C007K	C007-T30		Non-submerged
				Date
				2015/07/14

三針筒車上乘桌板圖
 C007J/C007K SERIES TABLE CUT-OUT SEMI-SUBMERGED
 單位/UNIT :mm
 FOR 印度客戶使用
 所有尺寸公差/DIFFERENCE:±2
 C007-T30-1070長度(L):1070/重量:11.3kg±5%
 C007-T30長度(L):1200/重量:12.3kg±5%
 全封邊灰格紋光塑面台板

