

SIRUBA®

銀箭牌工業用縫紉機
INDUSTRIAL SEWING MACHINE

BH780

使用說明與零件圖

INSTRUCTION AND PARTS LIST



CE



高林股份有限公司
KAULIN MFG. CO., LTD.

From the library of: Superior Sewing Machine & Supply LLC

零件冊

PARTS BOOK

CONTENTS

1. FRAME & MISCELLANEOUS COVER COMPONENTS
2. MAIN SHAFT COMPONENTS
3. HOOK DRIVING SHAFT COMPONENTS
4. PRESSER BAR. WORK CLAMP CARRIER COMPONENTS
5. NEEDLE BAR FRAME COMPONENTS
6. OVEREDGING WIDTH ADJUSTING COMPONENTS
7. NEEDLE THREAD TRIMMER COMPONENTS
8. BOBBIN THREAD TRIMMER COMPONENTS
9. KNIFE BAR COMPONENTS
10. FEED CAM & TRIPPING SEGMENT COMPONENTS
11. STOP-MOTION COMPONENTS
12. TRIPPING LEVER COMPONENTS
13. LIFTING LEVER & BOBBIN WINDER COMPONENTS
14. THREAD TENSION COMPONENTS
15. LUBRICATION MECHANISM COMPONENTS
16. SPEED TRANSMITTER COMPONENTS
17. EXCLUSIVE PARTS FOR 2784
18. EXCHANGING PARTS

目次

- 頭部外裝關係
- 上軸關係
- 下軸關係
- 押腳棒、布送板關係
- 針棒搖動台關係
- 針擺幅調節關係
- 上線切刀關係
- 下線切刀關係
- 刀棒關係
- 送布凸輪關係
- 遮斷裝置關係
- 手動停止關係
- 壓腳提升架、繞線器組
- 夾線器關係
- 給油裝置關係
- 減速機關係
- 專用零件
- 交換零件

1. FRAME & MISCELLANEOUS COVER COMPONENTS
頭部外裝關係

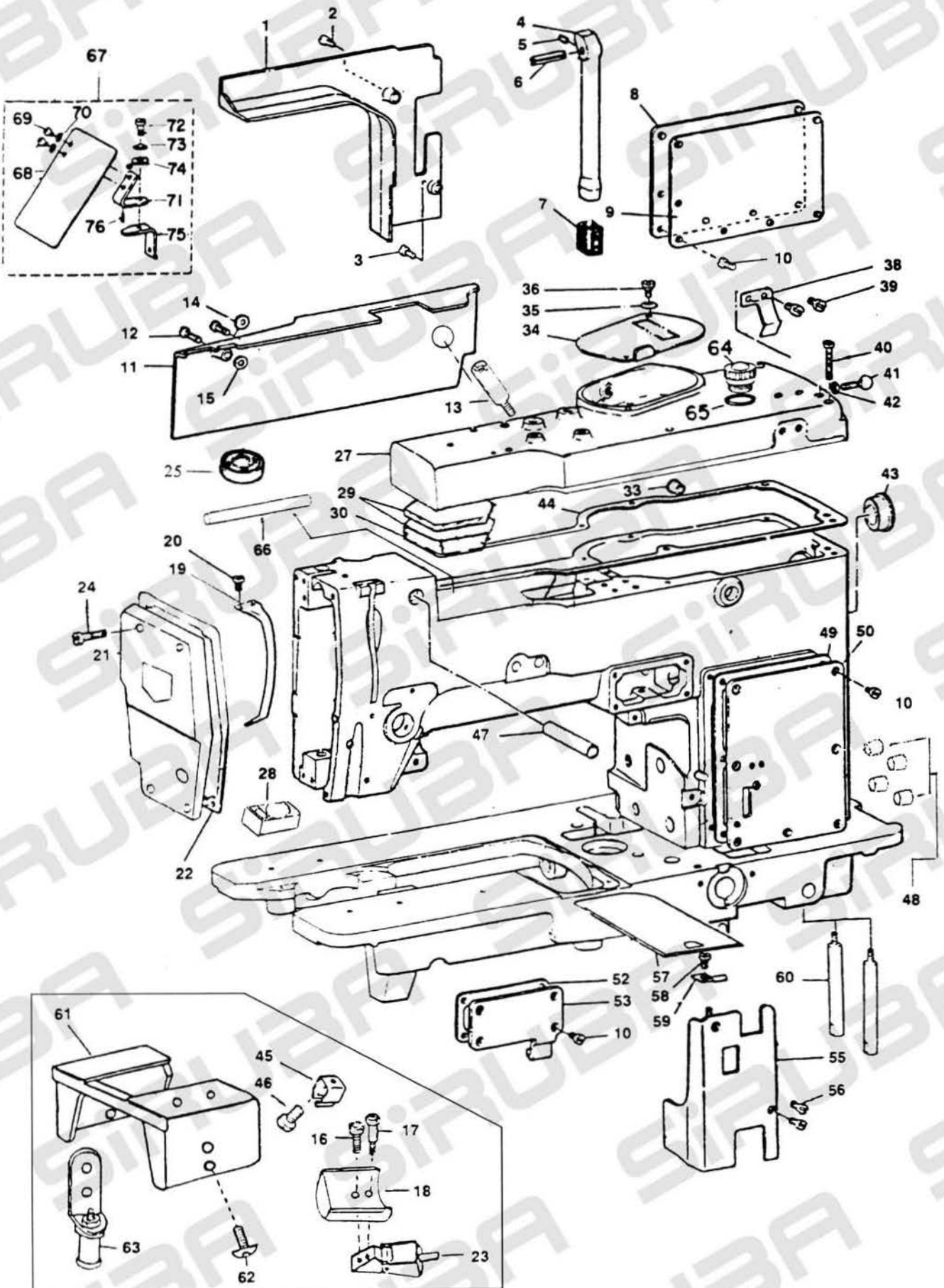

	Part No.	零件名稱	Description	Amt. Req.	1
1	801010	機殼側蓋	FRAME SIDE COVER	1	
2	801021	螺釘	SCREW	1	
3	-----			0	
4	801040	機頭支承臂	MACHINE ARM SUPPORT ROD	1	
5	801051	緊定螺釘	SCREW	1	
6	801060	彈性圓柱銷	PIN	1	
7	801070	橡膠緩衝墊	RUBBER CUSHION	1	
8	801080	側蓋板	SIDE COVER	1	
9	801090	側蓋板襯墊	SIDE COVER GASKET	1	
10	801101	螺釘	SCREW	21	
11	801110	機殼側蓋	FRAME SIDE COVER	1	
12	801121	螺釘	SCREW	2	
13	801131	螺釘	SCREW	1	
14	801140	緩衝墊	CUSHION	1	
15	801150	機殼側蓋襯墊	FRAME SIDE COVER GASKET	2	
16	801161	螺釘	SCREW	1	
17	801171	螺釘	SCREW	1	
18	801180	薄殼罩	THIN COVER	1	
19	801190	挑線杆護罩	THREAD TAKE-UP LEVER OIL GUARD	1	
20	801201	螺釘	SCREW	2	
21	801210	面板	FACE COVER COMPLETE	1	
22	801220	面板襯墊	GASKET	1	
23	801230	薄殼罩鉸鏈	THIN COVER HINGE	1	
24	801241	螺釘	SCREW	4	
25	801250	油封	OIL SEAL	2	
27	801270	頂蓋	TOP COVER	1	
28	801280	塑膠墊	PLASTIC GASKET	1	
29	801290	油氈	OIL FELT	2	
30	801300	油氈墊板	OIL FELT RETAINER	1	
33	801330	橡膠插塞	PLASTIC PLUG	1	
34	801340	齒輪箱蓋	GEAR CASE COVER	1	
35	801350	彈簧墊	DISC SPRING	1	
36	801361	鉸鏈螺釘	HINGE SCREW	1	
38	801380	手制動鉤	HAND STOP LATCH	1	
39	801391	螺釘	SCREW	2	
40	801401	螺釘	SCREW	6	
41	801411	球形螺釘	BALL SCREW	1	
42	801420	螺母	NUT	1	
43	801430	橡膠插塞	RUBBER PLUG	1	
44	801440	後頂蓋襯墊	TOP COVER GASKET,REAR	1	
45	801450	蓋鎖彈簧	COVER LATCH SPRING	1	
46	801461	螺釘	SCREW	1	
47	801470	停刀杆軸導向管	KNIFE STOP LEVER SHAFT GUIDE	1	
48	801480	橡膠插塞	RUBBER PLUG	1	
49	801490	側蓋板襯墊	SIDE COVER GASKET	1	
50	801500	側蓋板	SIDE COVER	1	
52	801520	襯墊	GASKET	1	
53	801530	側蓋	SIDE COVER	1	
55	801550	側蓋	SIDE COVER	1	
56	-----			0	
57	801570	推板	BED SLIDE	1	
58	801581	螺釘	SCREW	1	
59	801590	推板簧	BED SLIDE SPRING	1	
60	801600	底板支承螺釘	BED SCREW STUD	2	
61	801610	前蓋	FRONT COVER	1	
62	801621	螺絲	SCREW	4	
63	801630	前蓋鎖組件	FRONT COVER LATCH ASM.	2	
64	801640	油視窗	OIL SIGHT WINDOW	1	
65	801650	油視窗墊片	OIL SIGHT WINDOW GASKET	1	
66	801660	銅管	BUSHING	1	
67	801670	護目鏡組	SAFETY PLATE ASM	1	
68	801680	護目鏡片	SAFETY PLATE	1	
69	801691	螺釘	SCREW	2	
70	801700	華司	WASHER	2	
71	801710	護目鏡板	SAFETY PLATE INSTALLING PLATE	1	
72	801721	螺釘	SCREW	1	
73	801730	鐵片	DISC SPRING	1	
74	801740	華司	WASHER	1	
75	801750	護目鏡板	SAFETY PLATE MOUNTING BASE	1	
76	801760	彈簧銷	SPRING PIN	1	

2. MAIN SHAFT COMPONENTS
上軸關係

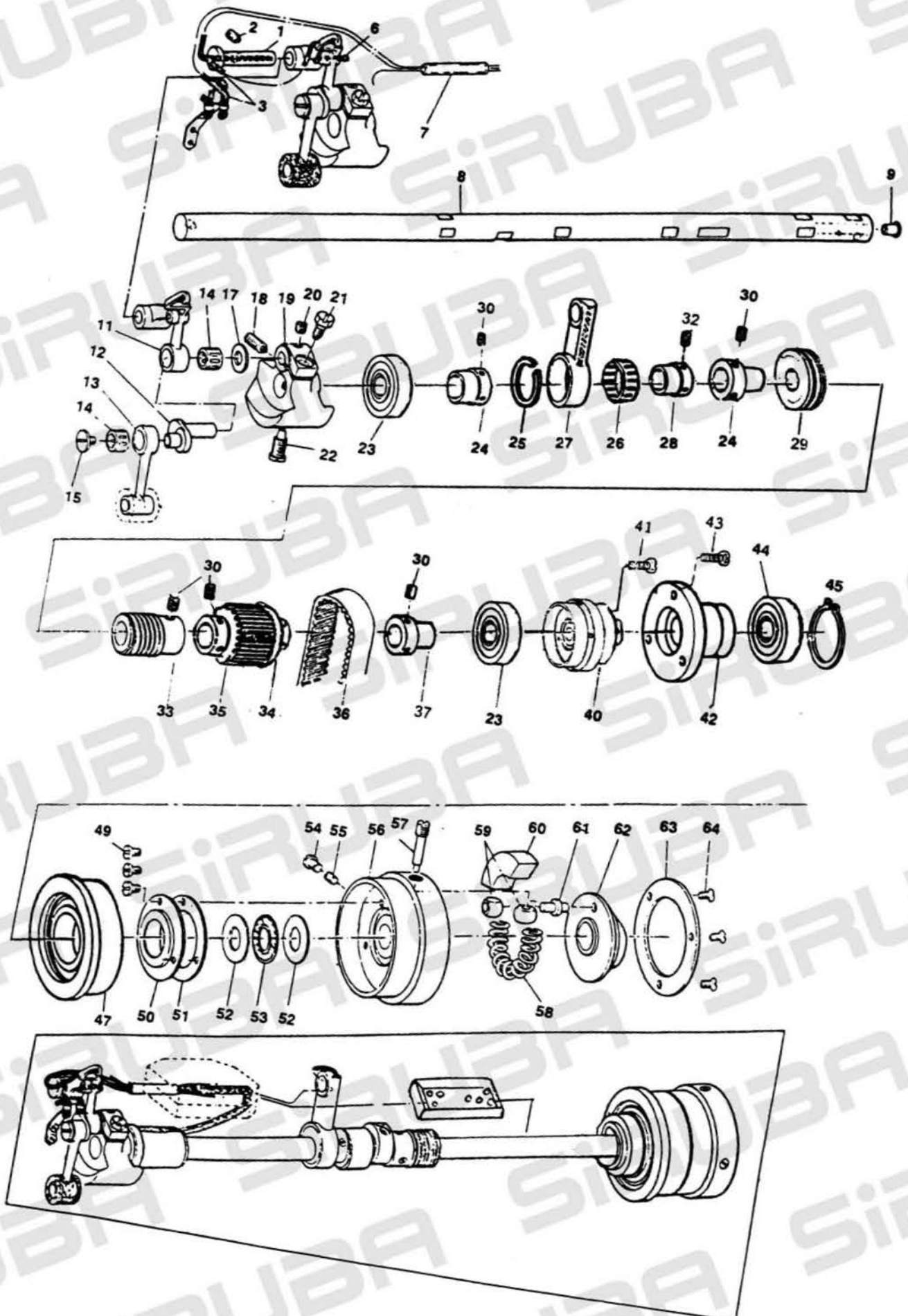

	Part No.	零件名稱	Description	Amt. 2 Req.
1	802010	鉸鏈銷	HINGE STUD	1
2	802021	螺釘	SCREW	1
3	802030	油芯	OIL WICK	1
4	-----			0
5	-----			0
6	802060	油芯環	OIL WICK SNAP RING	1
7	802070	乙烯管	VINYL TUBE	1
8	802080	上軸	MAIN SHAFT	1
9	802090	橡皮塞	RUBBER PLUG	1
10	-----			0
11	802110	挑線杆組件	THREAD TAKE-UP LEVER ASM.	1
12	802120	針杆曲柄	NEEDLE BAR CRANK	1
13	802130	針杆曲柄連杆	NEEDLE BAR CRANK CONNECTING ROD	1
14	802140	滾針軸承	NEEDLE BEARING	2
15	802151	左旋螺釘	END SCREW LEFT	1
16	-----			1
17	802170	止推墊圈	THRUST WASHER	1
18	802181	螺釘	SCREW	1
19	802190	平衡塊	COUNTER WEIGHT	1
20	802201	螺釘	SCREW	1
21	802211	螺釘	SCREW	1
22	802211	螺釘	SCREW	1
23	802230	軸承	BALL BEARING	2
24	802240	軸套	BALL BEARING	2
25	802250	扣環	RETAINING RING	1
26	802260	滾動軸承	ROLLER BEARING	1
27	802270	刀杆傳動連杆	KNIFE BAR DRIVING CONNECTING ROD	1
28	802280	刀杆傳動偏心凸輪	KNIFE BAR DRIVING ECCENTRIC CAM	1
29	802290	軸承	BALL BEARING	1
30	802301	螺釘	SCREW	10
31	-----			0
32	802321	螺釘	SCREW	4
33	802330	蝸杆	WORM	1
34	802340	鐵圈	IRON RING	1
35	802350	鏈輪	SHAFT SPROCKET	1
36	802360	皮帶	TIMING BELT	1
37	802370	軸套	ADAPTER	1
38	-----			0
39	-----			0
40	802400	上軸後軸承殼體	MAIN SHAFT BUSHING	2
41	802411	螺釘	SCREW	2
42	802420	上軸後軸承座	BEARING RETAINER	1
43	802430	螺釘	ADAPTER	3
44	802440	球軸承	BALL BEARING	1
45	802450	扣環	RETAINING RING	1
47	802470	空轉帶輪	LOOSE PULLEY	1
48	-----			0
49	802491	螺釘	SCREW	3
50	802500	主軸止推密封圈	MAIN SHAFT THRUST SEEL	1
51	802510	襯墊	GASKET	1
52	802520	滾針軸承前後蓋	THRUST WASHER	2
53	802530	推力滾針軸承	BEARING	1
54	802541	螺釘	SCREW	1
55	802551	螺釘	SCREW	1
56	802560	傳動帶輪	DRIVING PULLEY	1
57	802571	螺釘	SCREW	1
58	802580	止動凸輪壓簧	STOP CAM PRESSURE SPRING	1
59	802590	止動凸輪滑塊	STOP-MOTION CAM PIN SLIDE BLOCK	2
60	802600	電木扇形塊	BAKELITE SEGMENT	1
61	802610	止動凸輪定位銷	STOP-MOTION CAM POSITION PIN	1
62	802620	止動凸輪	STOP-MOTION CAM	1
63	802630	止動凸輪壓板	STOP-MOTION CAM PRESSER PLATE	1
64	802641	螺釘	SCREW	3

3. HOOK DRIVING SHAFT COMPONENTS 下軸關係

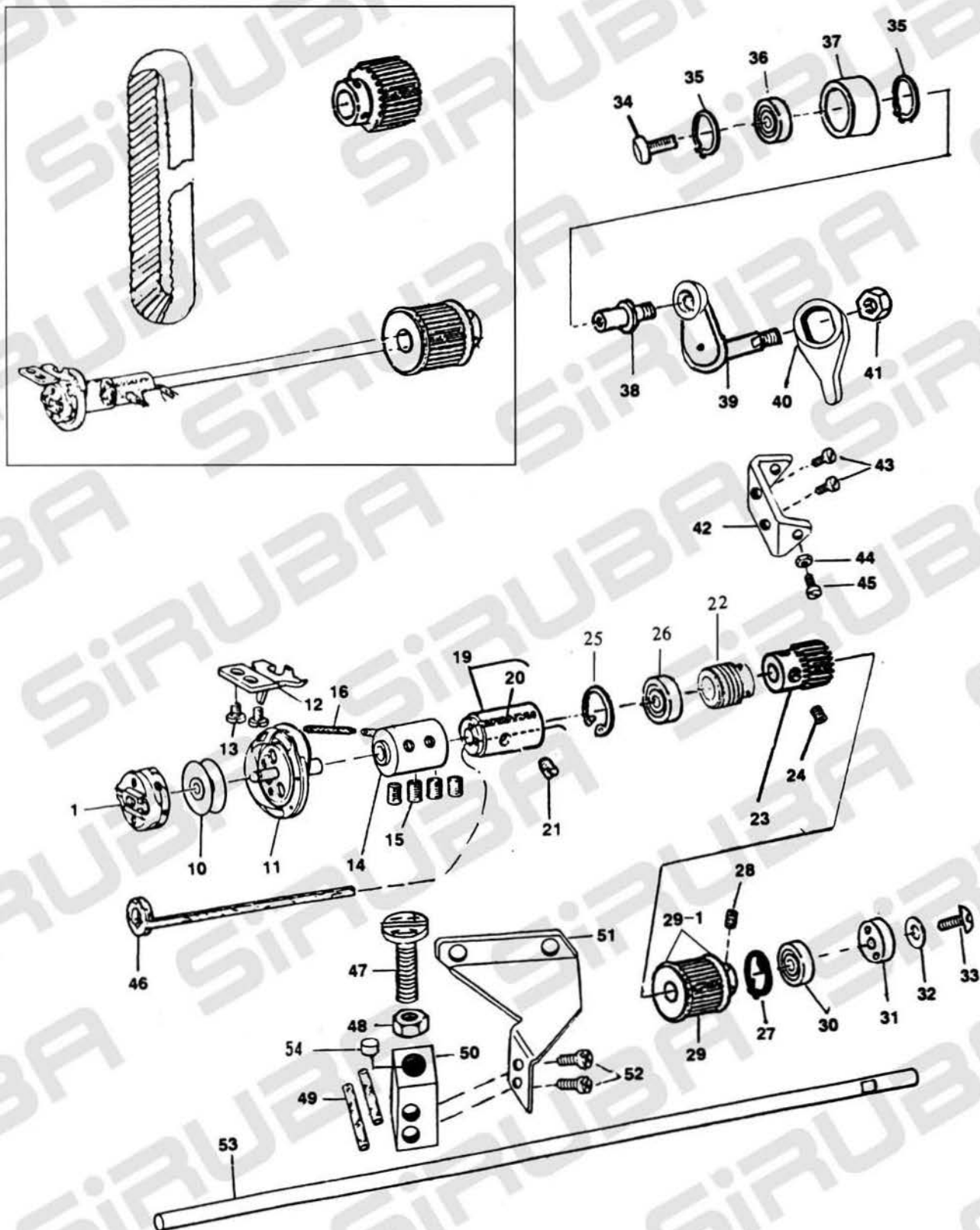

	Part No.	零件名稱	Description	Amt. Req.	3
1	803010	梭殼組件	BOBBIN CASE ASM.	1	
10	803100	梭子	BOBBIN	1	
11	803110	旋梭套組件	HOOK C ASM.	1	
12	803120	梭子定位板	BOBBIN CASE POSITIONING PLATE	1	
13	803131	螺釘	SCREW	2	
14	803140	旋梭軸套組件	HOOK SLEEVE ASM.	1	
15	803151	螺釘	SCREW	4	
16	803160	油芯	OIL WICK	1	
17	-----			0	
18	-----			0	
19	803190	下軸前套管	BUSHING ASM.	1	
20	803200	油芯	OIL WICK	1	
21	803211	螺釘	SCREW	1	
22	803220	蝸杆	WORM	0	
23	803230	小齒輪	PINION	1	
24	803241	螺釘	SCREW	2	
25	803251	扣環	RETAINING RING	1	
26	803260	球軸承	BALL BEARING	1	
27	803270	扣環	RETAINING RING	1	
28	803281	螺釘	SCREW	2	
29	803290	皮帶鏈輪	BELT SPROCKET	1	
29-1	803290-1	鐵圈	IRON RING	2	
30	803300	球軸承	BALL BEARING	1	
31	803310	軸承固定擋圈	COLLAR	1	
32	803320	墊圈	WASHER	1	
33	803331	螺釘	SCREW	1	
34	803341	螺釘	SCREW	1	
35	803350	扣環	RETAINING RING	1	
36	803360	球軸承	BALL BEARING	1	
37	803370	皮帶張緊輪	TENSION PULLEY	1	
38	803380	調整槓桿針	ADJUSTING LEVER PIN	1	
39	803390	張緊輪連杆	TENSION PULLEY LINK	1	
40	803400	調節配件	ADJUSTING GUIDE	1	
41	803410	螺母	NUT	1	
42	803420	調節杆座	ADJUSTING BASE	1	
43	803431	螺釘	SCREW	2	
44	803440	螺母	NUT	2	
45	803451	螺釘	SCREW	2	
46	803460	油氈	OIL FELT	1	
47	803470	旋梭調節潤滑螺釘	HOOK OIL ADJUSTING SCREW	1	
48	803480	螺母	NUT	1	
49	803490	油管	OIL TUBE	2	
50	803500	調節潤滑螺釘座	OIL ADJUSTING SCREW BASE	1	
51	803510	調節潤滑螺釘座架	OIL ADJUSTING SCREW BRACKET	1	
52	803521	螺釘	SCREW	2	
53	803530	下軸	HOOK DRIVING SHAFT	1	
54	803540	油控制閥	OIL CONTROL BASE	1	

	Part No.	零件名稱	Description	Amt. Req. 4
1	804010	壓簧調節	PRESSER SPRING REGULATOR	1
2	804020	壓棒	PRESSER BAR	1
3	804030	壓簧	PRESSER SPRING	1
4	804040	導向支架	GUIDE BRACKET	1
5	-----			0
6	804060	壓棒定位架	PRESSER BAR POSITION BRACKET	1
7	804071	螺釘	SCREW	1
8	804080	套管	COLLAR	1
9	804090	滑動滾輪	SLIDE ROLLER	1
10	804100	滑動滾輪銷	CONNECTING PIN	1
11	804110	支架	BRACKET	1
12	804120	安全防護	SAFE DEFEND GUIDE	1
13	804131	壓棒螺釘	SCREW	1
14	804141	螺釘	SCREW	2
15	804150	導向支架	GUIDE BRACKET	1
16	804161	螺釘	SCREW	2
17	804171	螺釘	SCREW	2
18	804181	螺釘	SCREW	2
19	804190	面線剪斷器導架	NEEDLETHREAD TRIMMER GUIDE	1
20	804200	面線剪斷器導架	NEEDLETHREAD TRIMMER GUIDE	1
21	804210	壓腳板座	WORK CLAMP CHECK HOLDER	1
22	804220	壓腳板座彈簧銷	WORK CLAMP CHECK HOLDER SPRING	1
23	804230	壓腳彈簧板	WORK CLAMP CHECK SPRING	2
24	804240	壓腳彈簧定位銷	WORK CLAMP CHECK SPRING SET PIN	2
25	804251	鉸鏈銷螺釘	HINGE SCREW	1
26	804261	螺釘	SCREW	2
27	804270	壓腳板	WORK CLAMP CHECK	1
28	804280	壓腳板座組	WORK CLAMP CHECK HOLDER ASM.	1
29	-----			0
30	804300	送布拖板	STITCH PLATE	1
31	804310	支架蓋板組件	BRACKET COVER	1
31-1	804310-1	支架蓋板(小)	BRACKET PLATE (SMALL)	1
31-2	804310-2	支架蓋板(大)	BRACKET PLATE (BIG)	1
31-3	804310-3	蓋板梢	BRACKET PIN	1
32	804321	螺釘	SCREW	2
33	804330	送料支架	WORK CLAMP ARM BRACKET ASM	1
34	804341	螺釘	SCREW	1
35	804350	送料支架連杆	WORK CLAMP CARRIER BRACKET PITMAN	1
36	804361	鉸鏈銷螺釘	HINGE SCREW	1
37	804370	壓腳臂滑杆	WORK CLAMP ARM SLIDE ROD	1
38	804380	送布拖板支架導塊	WORK CLAMP CARRIER BRACKET GUIDE	1
39	804391	螺釘	SCREW	2
40	804400	布料夾支架	WORK CLAMP BRACKET	1
41	804410	連接銷	CONNECTING PIN	1
42	804421	螺釘	SCREW	1
43	804430	拖架	BEARING ARM	1
44	804441	螺釘	SCREW	1
45	804451	螺釘	SCREW	1
46	804461	調節送料長度鉸鏈銷螺釘	LENGTH REGULATING HINGE STUD	1
47	804470	調節送料長度軸導板	LENGTH REGULATING SHAFT GUIDE	1
48	804480	螺母	NUT	1
49	804490	調節送料長度刻度盤組件	LENGTH REGULATING SCALE ASM.	1
49-1	804490-1	刻度盤桿	LENGTH REGULATING SCALE LEVER	1
50	804500	曲柄	BELL CRANK	1
51	804511	螺釘	SCREW	1
52	804520	滾子	ROLLER	1
53	804530	曲柄滾子銷	BELL CRANK ROLLER STUD	1
54	804540	螺母	NUT	1

5. NEEDLE BAR FRAME COMPONENTS
針棒搖動台關係

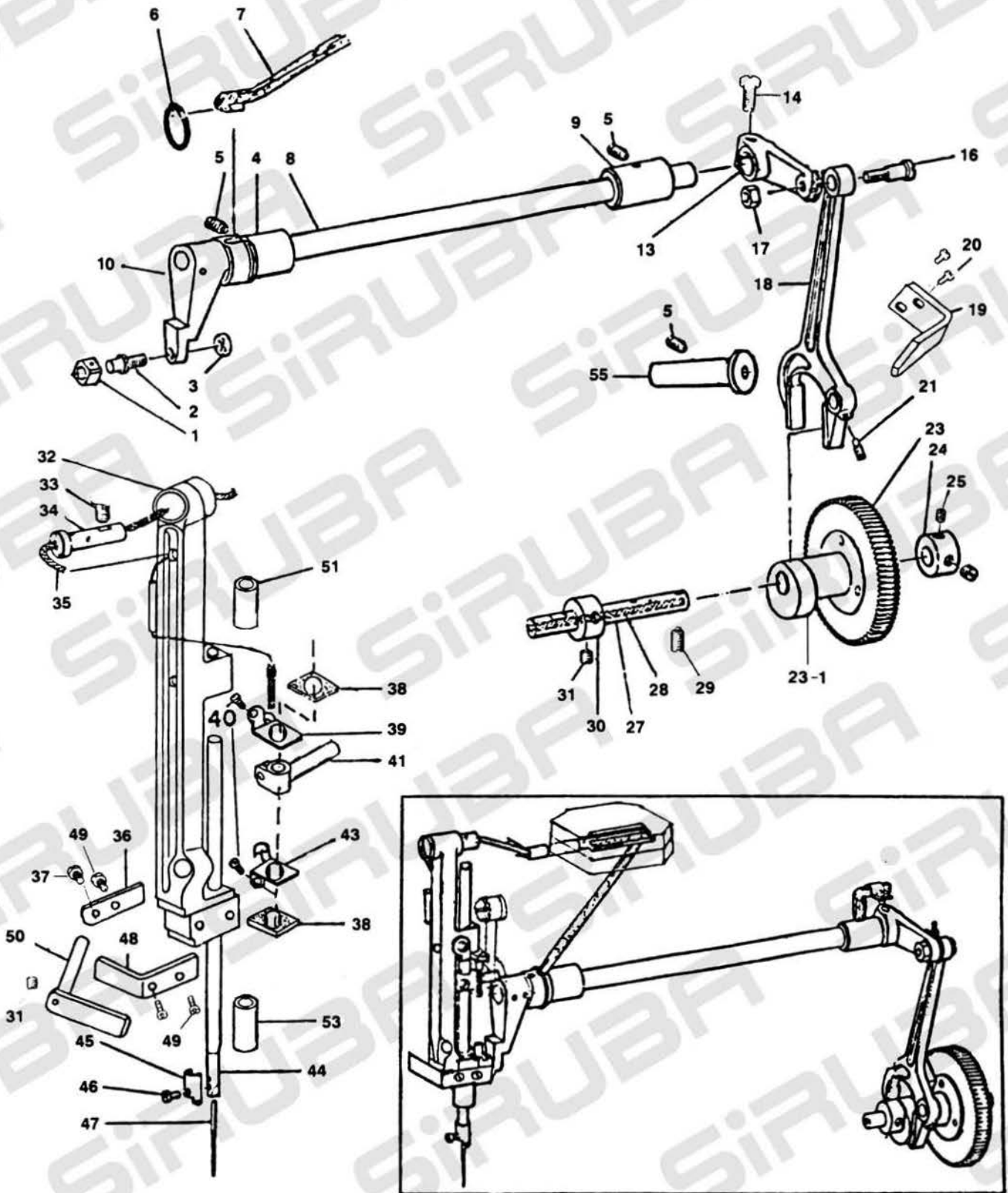

	Part No.	零件名稱	Description	Amt. 5 Req.
1	805010	針杆架滑塊	NEEDLE BAR CONNECTION SLIDE BLOCK	1
2	805021	滑塊銷螺釘	STUD	1
3	805030	螺母	NUT	1
4	805040	擺杆前套管	FRAME ROCK SHAFT BUSHING,FRONT	1
5	805051	螺釘	SCREW	3
6	805060	O型密封圈	O-TYPE RUBBER	1
7	805070	油芯	OIL WICK	1
8	805080	擺杆軸心		1
9	805090	擺杆後套管	FRAME ROCK SHAFT BUSHING,REAR	1
10	805100	千鳥擺動曲柄	FRAME ROCK SHAFT CRANK,	1
13	805130	擺杆後柄	FRAME ROCK SHAFT CRANK,FRONT	1
14	805141	螺釘	SCREW	1
15	-----			0
16	805161	鉸鏈銷螺釘	HINGE SCREW	1
17	805170	螺母	NUT	1
18	805180	針杆搖杆	NEEDLE BAR PITMAN	1
19	805190	擺杆連接導板	ROCK SHAFT CONNECTION GUIDE	1
20	805201	螺釘	SCREW	2
21	805211	螺釘	SCREW	1
22	-----			
23	805230	機針傳動齒輪組件	NEEDLE DRIVING GEAR	1
23-1	805230-1	齒輪架	GEAR HOLDER	1
24	805240	擋圈	THRUST COLLAR	1
25	805251	螺釘	SCREW	2
26	-----			0
27	805270	凸輪軸心	CAM SHAFT	1
28	805280	油繩	OIL WICK	1
29	805291	螺釘	SCREW	1
30	805300	擋圈	THRUST COLLAR	1
31	805311	螺釘	SCREW	5
32	805320	針杆架	NEEDLE BAR FRAME	1
33	805331	螺釘	SCREW	1
34	805340	鉸鏈銷	HINGE STUD	1
35	805350	油繩	OIL WICK	1
36	805360	左固定片	RETAINER,LEFT	1
37	805371	螺釘	SCREW	1
38	805380	毛氈	FELT	2
39	805390	油繩高端固定板	OIL FELT RETAINER,HIGH	1
40	805401	螺釘	SCREW	2
41	805410	針杆連接杆	NEEDLE BAR CONNECTION	1
42	-----			0
43	805430	油繩低端固定板	OIL FELT RETAINER,LOWER	1
44	805440	針杆	NEEDLE BAR	1
45	805450	針杆導線架	NEEDLE BAR BOBBIN THREAD GUIDE	1
46	805461	螺釘	SCREW	1
47	805470	機針	NEEDLE DPx5	1
48	805480	右固定片	RETAINER,RIGHT	1
49	805491	螺釘	SCREW	2
50	805500	固定導片	POSITION BRACKET	1
51	805510	針棒襯套管	NEEDLE BAR BUSHING	1
52	-----			0
53	805530	針棒襯套管	NEEDLE BAR BUSHING	1
54	-----			0
55	805550	軸心	SHAFT	1

6. OVEREDGING WIDTH ADJUSTING COMPONENTS
 針擺幅調節關係

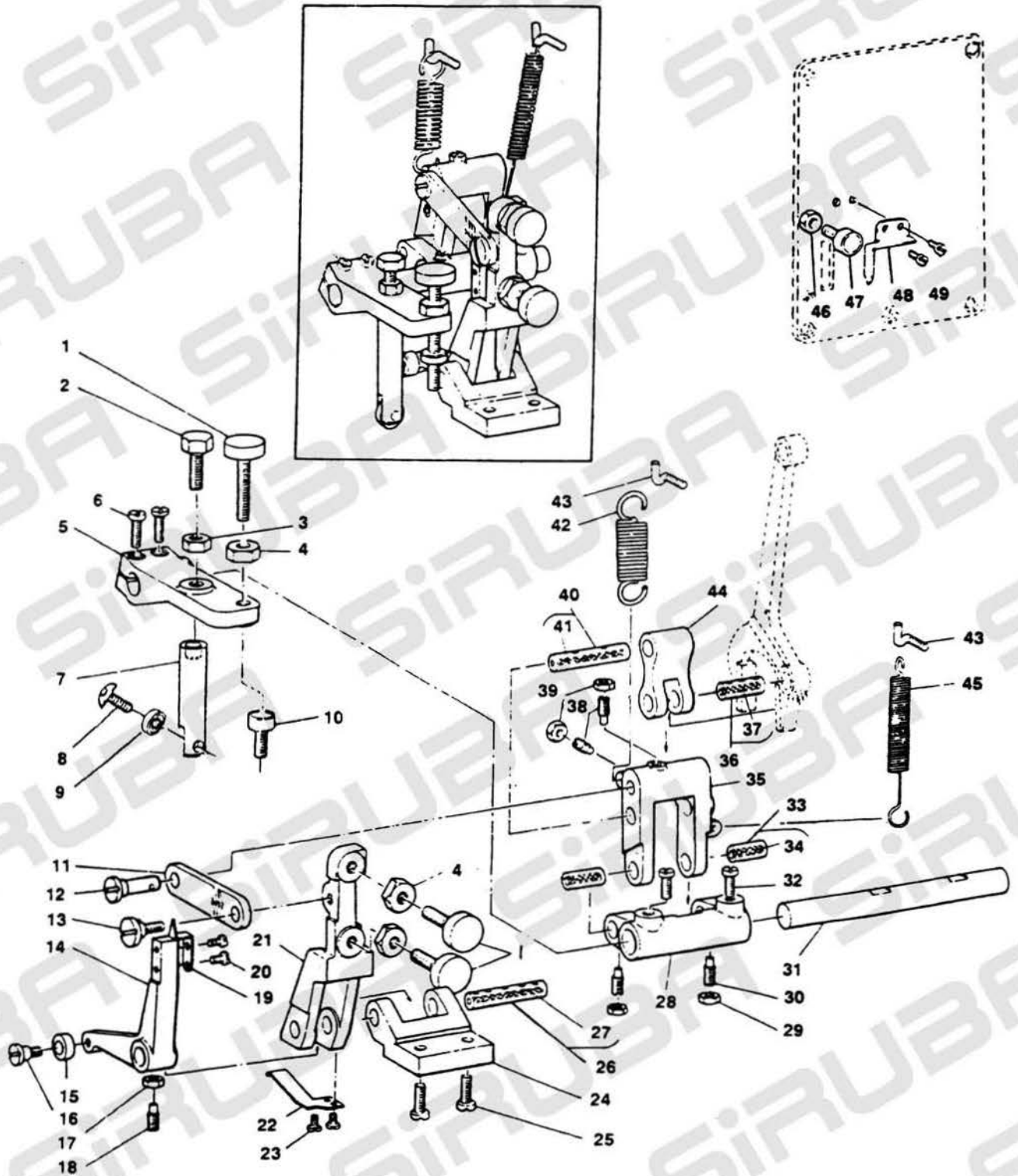

	Part No.	零件名稱	Description	Amt. 6 Req.
1	806011	線跡寬度調節螺釘	STITCH WIDTH REGULATING SCREW	3
2	806021	螺釘	SCREW	1
3	-----			0
4	806040	螺母	NUT	4
5	806050	復位杆	REPOSITIONING LEVER	1
6	806061	螺釘	SCREW	2
7	806070	離合杆	TRIPPING ROD	1
8	806081	螺釘	SCREW	1
9	806090	滾輪	BALL BEARING	1
10	806101	調節杆螺釘	REGULATING LEVER STOPPER	1
11	806110	調節杆連接板	REGULATING LEVER CONNECTION	1
12	806120	調節銷	REGULATING HINGE PIN	1
13	806131	鉸鏈銷螺釘	HINGE SCREW	1
14	806140	指示曲柄	BELL CRANK	1
15	806150	滾輪	ROLLER	1
16	806161	鉸鏈銷螺釘	HINGE SCREW	1
17	-----			0
18	806181	螺釘	SCREW	5
19	806190	刻度指示針	BARRED WIDTH INDICATOR	1
20	806201	螺釘	SCREW	6
21	806210	調節杆叉	REGULATING LEVER	1
22	806220	彈簧板	SPRING	1
23	806231	螺釘	SCREW	2
24	806240	調節杆座	REGULATING LEVER BRACKET	1
25	806251	螺釘	SCREW	2
26	806260	調節杆軸	REGULATING LEVER SHAFT	1
27	806270	油繩	OIL WICK	1
28	806280	軸承座	BEARING BRACKET	1
29	806290	螺母	NUT	2
30	806301	緊定螺釘	SCREW	2
31	806310	針擺復位軸	NEEDLE THROW REPOSITIONING SHAFT	1
32	806321	螺釘	SCREW	2
33	806330	連接銷	BEARING BRACKET	2
34	806340	油繩	OIL WICK	2
35	806350	叉形連杆	REPOSITIONING LEVER LINK	1
36	806360	連接銷	CONNECTING FORKED LINK PIN	1
37	806370	油繩	OIL WICK	1
38	-----			0
39	-----			0
40	806400	連接銷	CONNECTING STUD	1
41	806410	油繩	OIL WICK	1
42	806420	拉簧	SPRING	1
43	806431	懸掛螺釘	SUSPENSION SCREW	2
44	806440	叉形連杆	CONNECTING FORKED LINK	1
45	806450	拉簧	SPRING	1
46	806460	螺母	NUT	1
47	806471	調節杆限位螺釘	REGULATING LEVER STOPPER	1
48	806480	縫寬指示針	SEAM WIDTH INDICATOR	1
49	806491	螺釘	SCREW	2

7. NEEDLE THREAD TRIMMER COMPONENTS
上線切刀關係

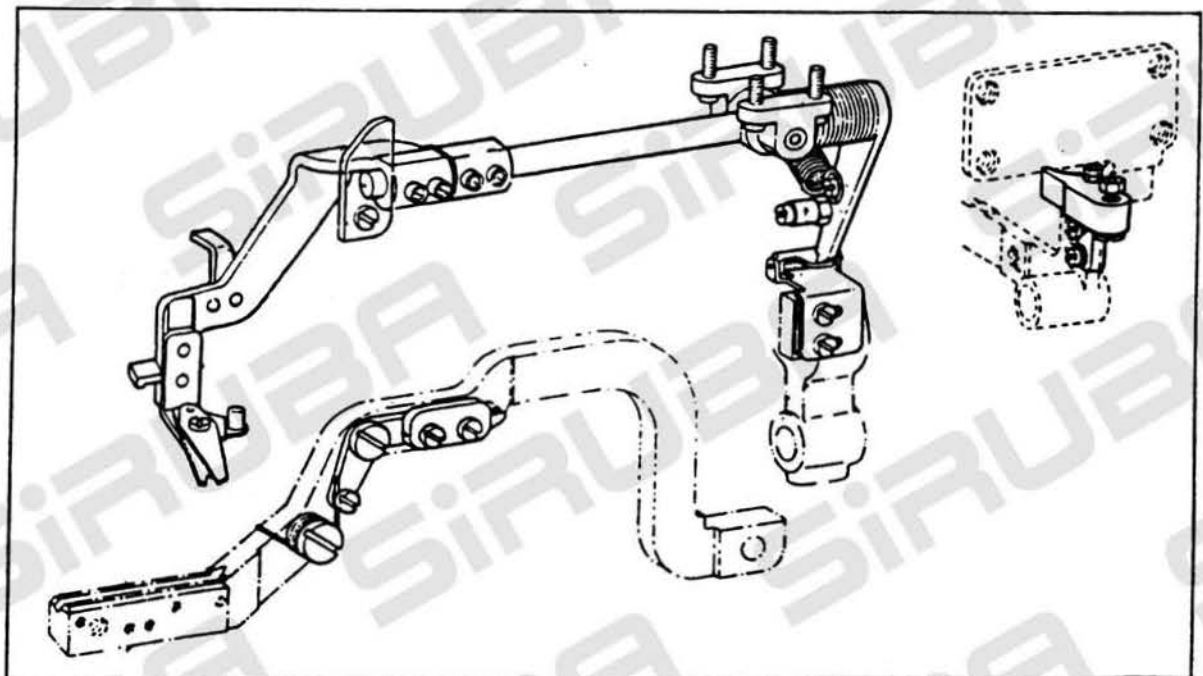
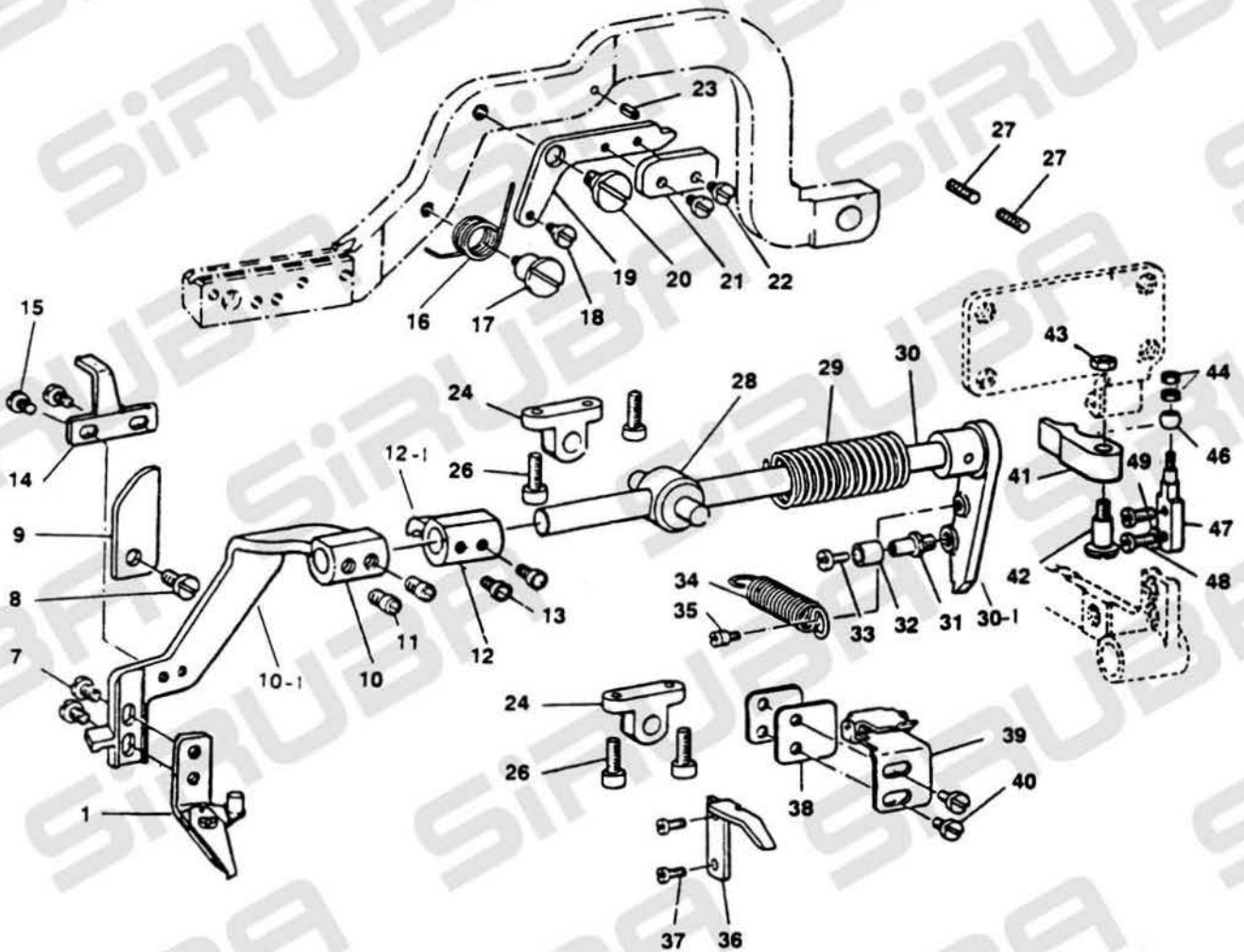

	Part No.	零件名稱	Description	Amt. 7 Req.
1	807010	面線修整器組件	NEEDLE THREAD TRIMMER ASM.	1
7	807071	螺釘	SCREW	2
8	807081	螺釘	SCREW	1
9	807090	剪面線器軸導板	NEEDLE THREAD TRIMMER SHAFT GUIDE	1
10	807100	保持架組件	THREAD TRIMMER HOLDER	1
10-1	807100-1	剪刀架	NEEDLE THREAD TRIMMER HOLDER	1
11	807111	螺釘	SCREW	4
12	807120	剪面線保持架組件	THREAD TRIMMER HOLDER	1
12-1	807120-1	附件	THREAD TRIMMER HOLDER ATTACHMENT	1
13	-----			0
14	807140	限位板	LIMITING PLATE	1
15	807151	螺釘	SCREW	2
16	807160	轉矩彈簧	DRIVING CAM SPRING	1
17	807170	傳動凸輪轉矩彈簧軸	DRIVING CAM SPRING AXLE	1
18	807181	鉸鏈銷螺釘	HINGE SCREW	1
19	807190	傳動凸輪安裝板	DRIVING CAM INSTALLING PLATE	1
20	807201	鉸鏈銷螺釘	HINGE SCREW	1
21	807210	傳動凸輪板	DRIVING CAM	1
22	807221	螺釘	SCREW	2
23	807230	彈性圓柱銷	SPRING PIN	1
24	807240	支架	BRACKET	2
25	-----			
26	807261	螺釘	SCREW	4
28	807280	萬向接頭	UNI ERSAL JOINT	1
29	807270	彈簧	SPRING	1
30	807300	剪面線器軸組件	NEEDLE THREAD TRIMMER SHAFT	1
30-1	807300-1	剪面線器進出移動件	NEEDLE THREAD TRIMMER MOVEABLE BASE	1
31	807310	滾輪銷	STUD	1
32	807320	滾子	CAM ROLL	1
33	807331	螺釘	SCREW	1
34	807340	彈簧	SPRING	1
35	807351	懸掛螺釘	SUSPENSION SCREW	1
36	807360	壓腳臂鎖門	LATCH PRESSER ARM	1
37	807371	螺釘	SCREW	2
38	807380	墊片	SPACER	2
39	807390	鎖架組件	LOCKING BRACKET LATCH	1
40	807401	螺釘	SCREW	2
41	807410	剪線軸頂塊	THREAD TRIMMING SHAFT SEGMENT	1
42	807421	鉸鏈銷螺釘	HINGE SCREW	1
43	807430	螺母	NUT	1
44	807440	螺母	NUT	2
45	-----			0
46	807460	滾柱	ROLLER	1
47	807470	嵌件	STUD	1
48	807481	螺釘	SCREW	2
49	807490	墊圈	WASHER	1

8. BOBBIN THREAD TRIMMER COMPONENTS
下線切刀關係

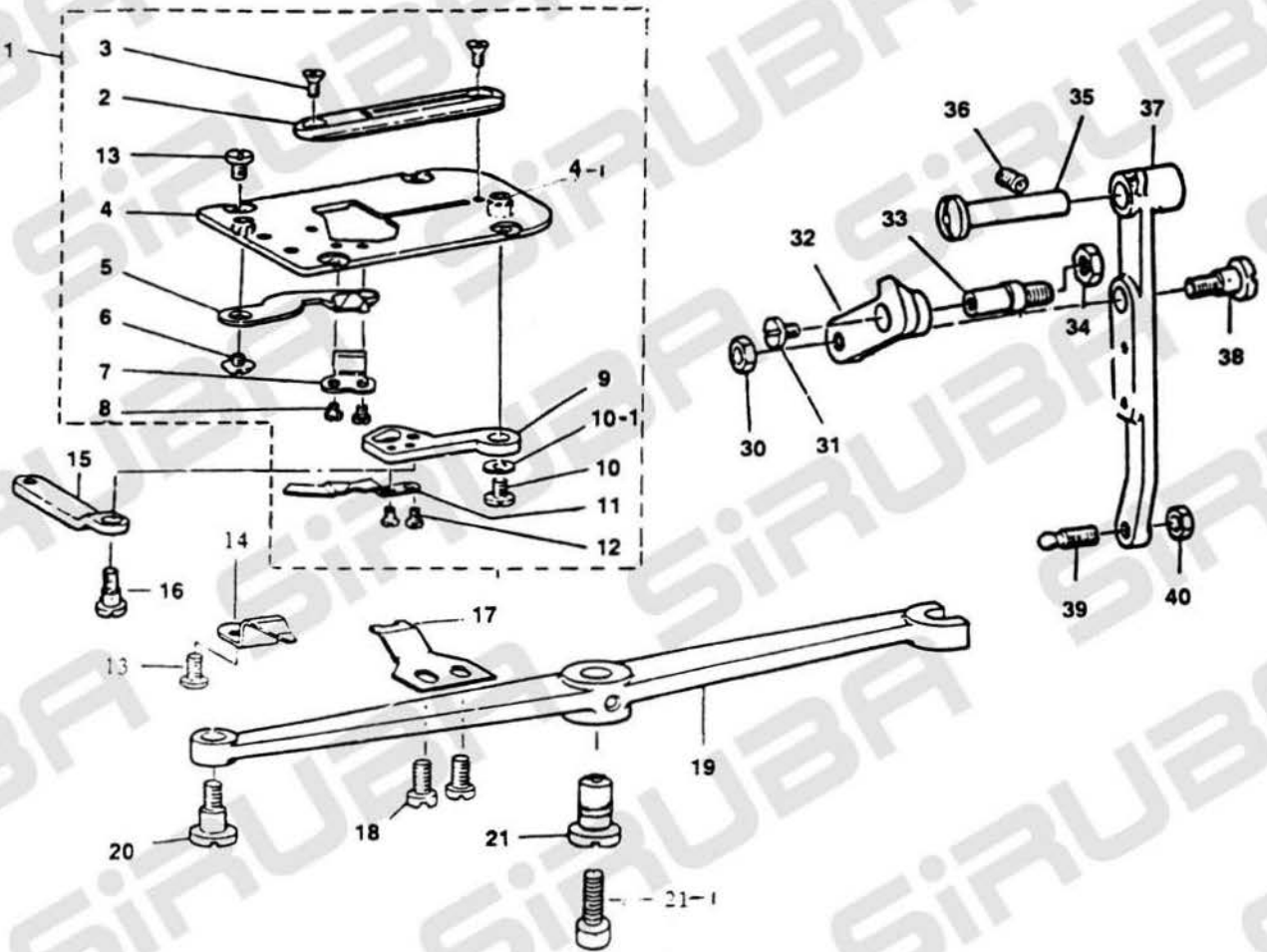

EXCLUSIVE PARTS FOR 890 (CYLINDER BED MACHINE)
890 專用零件 (筒狀機台)

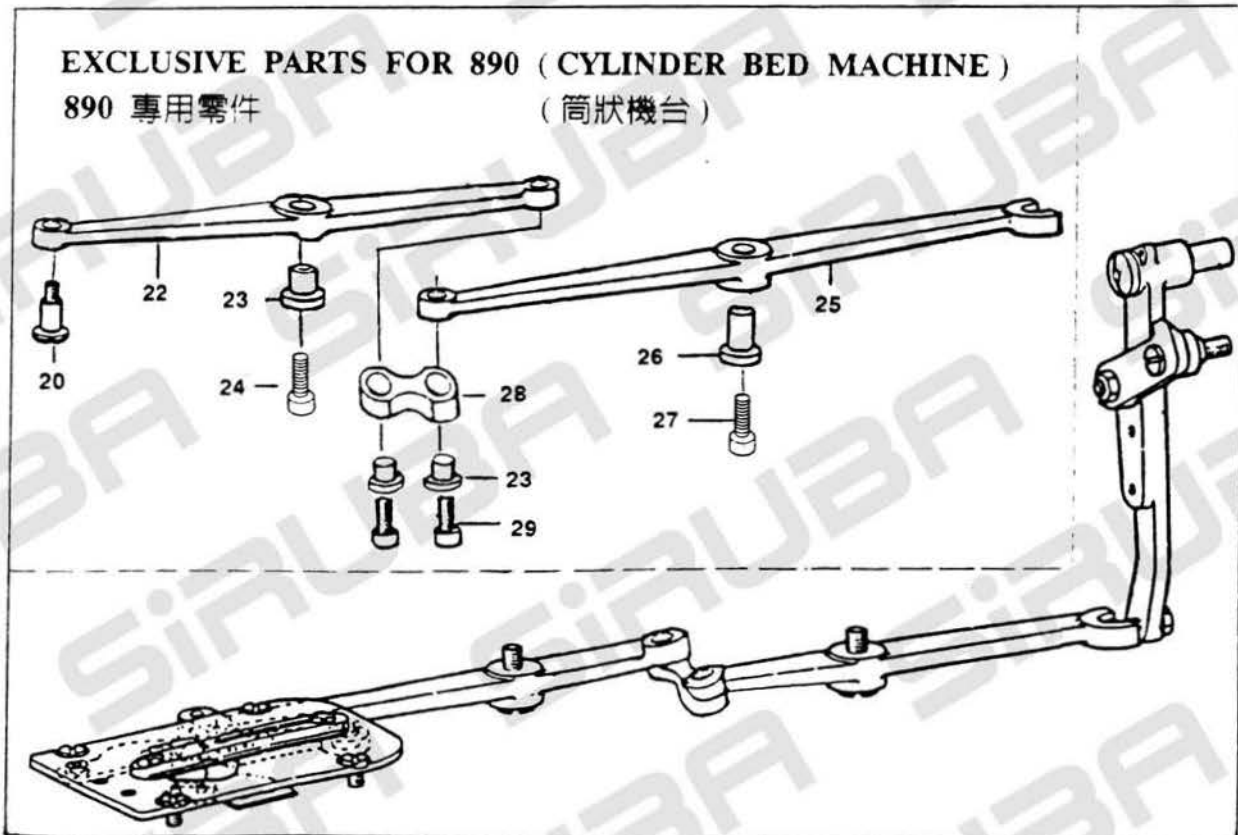

	Part No.	零件名稱	Description	Amt. 8 Req.
1	808010	剪底線器組件	BOBBIN THREAD TRIMMER ASM.	1
2	808020	針板	NEEDLE PLATE	1
3	808031	螺釘	SCREW	2
4	808040	針板座	THROAT PLATE BASE	1
4-1	808040-1	附件	ATTACHMENT	1
5	808050	剪底線動刀	BOBBIN THREAD TRIMMER	1
6	808061	螺釘	SCREW	1
7	808070	剪底線定刀	COUNTER KNIFE	1
8	808081	定刀螺釘	SCREW	2
9	808090	剪底線杆	BOBBIN THREAD TRIMMER LEVER	1
10	808101	螺釘	SCREW	1
10-1	808100	墊圈	WASHER	1
11	808110	底線拉杆	BOBBIN THREAD PULLER	1
12	808121	螺釘	SCREW	2
13	808131	螺釘	SCREW	4
14	808141	壓板	PRESS PLATE	1
15	808150	剪底線連杆	BOBBIN THREAD TRIMMER LINK	1
16	808161	螺釘	SCREW	1
17	808170	梭芯導線架	BOBBIN THREAD GUIDE	1
18	808181	螺釘	SCREW	2
19	808190	剪底線傳動杆	BOBBIN THREAD TRIMMER DRIVING LEVER	1
20	808201	鉸鏈銷螺釘	HINGE SCREW	1
21	808211	鉸鏈銷螺釘	HINGE SCREW	1
22	808220	剪底線傳動杆	BOBBIN THREAD TRIMMER DRIVING LEVER	1
23	808230	套筒	SLEEVE	3
24	808241	鉸鏈銷螺釘杆套筒	HINGE SCREW	1
25	808250	剪底線傳動杆	BOBBIN THREAD TRIMMER DRIVING LEVER	1
26	808260	套筒	SLEEVE	1
27	808271	螺釘	SCREW	1
28	808280	剪底線傳動杆連接	DRIVING LEVER CONNECTION	1
29	808291	螺釘	SCREW	2
30	808300	螺母	NUT	1
31	808311	螺釘銷	SCREW	1
32	808320	凸輪連杆	CONNECTING LINK	1
33	808331	限位螺釘	STOP SCREW	1
34	808340	螺母	NUT	1
35	808350	鉸鏈銷	HINGE STUD	1
36	808361	緊定螺釘	SCREW	1
37	808370	剪底線器傳動臂	BOBBIN THREAD TRIMMER DRIVING ARM	1
38	808381	鉸鏈銷螺釘	HINGE SCREW	1
39	808391	球形螺釘	BALL SCREW	1
40	808400	螺母	NUT	1

9. KNIFE BAR COMPONENTS

刀棒關係

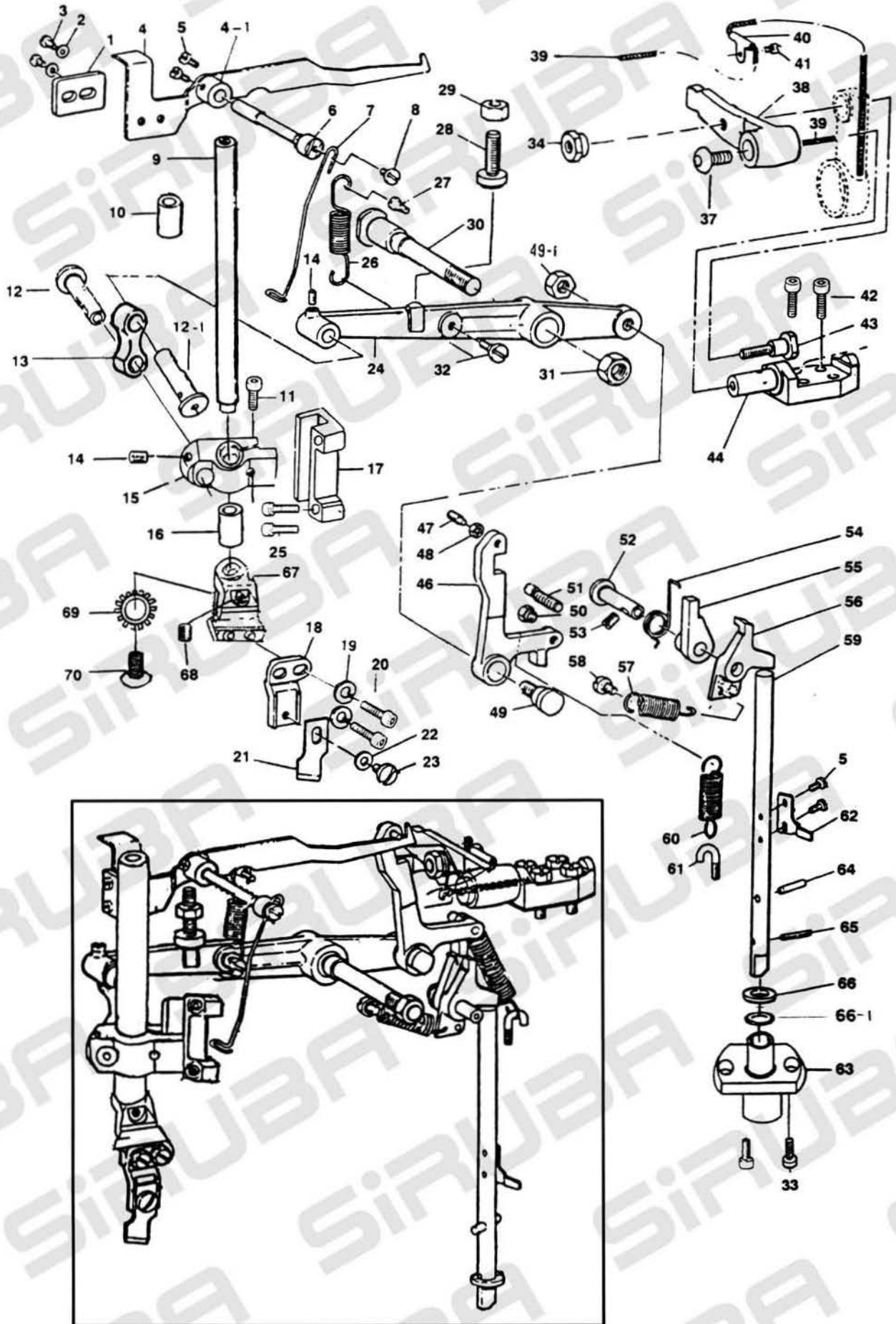

	Part No.	零件名稱	Description	Amt. 9 Req.
1	809010	停刀杆架	KNIFE STOP LEVER BRACKET	1
2	809020	墊圈	WASHER	2
3	809031	螺釘	SCREW	2
4	809040	停刀杆	KNIFE STOP LEVER	1
4-1	809040-1	停刀杆組件	KNIED STOP LEVER ASM	1
5	809051	螺釘	SCREW	4
6	809060	停刀杆鉸鏈銷	KNIFE STOP LEVER HINGE STUD	1
7	809070	線檢測鋼絲	THREAD CHECK WIRE	1
8	809081	螺釘	SCREW	1
9	809090	刀杆	KNIFE BAR	1
10	809100	套管	KNIFE BAR BUSHUNG	1
11	809111	螺釘	SCREW	1
12	809120	連桿銷(長)	CONNECTING LINK PIN(LONG)	2
12-1	809120-1	連桿銷(短)	CONNECTING LINK PIN(SHORT)	1
13	809130	刀杆連杆	KNIFE BAR CONNECTING LINK	1
14	809141	螺釘	SCREW	2
15	809150	刀杆定位架	KNIFE BAR POSITION BRACKET	1
16	809160	套管	KNIFE BAR BUSHING	1
17	809170	刀杆導引	KNIFE BAR GUIDE	1
18	809180	刀固定架	KNIFE HOLDER	1
19	809190	彈簧墊圈	SPRING WASHER	1
20	809201	螺釘	SCREW	2
21	809210	1/2"刀	KNIFE 1/2"	1
22	809220	墊圈	WASHER	1
23	809231	螺釘	SCREW	1
24	809240	刀杆傳動杆	KNIFE BAR DRIVING LEVER	1
25	809251	螺釘	SCREW	2
26	809260	彈簧	SPRING	1
27	809271	鉸鏈銷螺釘	HINGE SCREW	1
28	809281	調節螺釘	ADJUSTING SCREW	1
29	809290	螺母	NUT	2
30	809300	刀杆傳動杆軸	KNIFE BAR DRIVING LEVER SHAFT	1
31	809310	螺母	NUT	1
32	809321	鉸鏈銷螺釘	HINGE SCREW	1
33	809330	螺絲	SCREW	2
34	809340	刀杆傳動杆螺母	KNIFE BAR DRIVING CRANK NUT	1
37	809371	螺釘	SCREW	1
38	809380	刀杆傳動杆曲柄	KNIFE BAR DRIVING CRANK	1
39	809390	油芯	OIL WICK	1
40	809400	油芯保持架	OIL WICK HOLDER	1
41	809411	螺釘	SCREW	1
42	809421	螺釘	SCREW	2
43	809431	鉸鏈銷螺釘	HINGE SCREW	1
44	809440	刀杆傳動曲柄軸	KNIFE BAR DRIVING CRANK SHAFT	1
46	809460	刀杆傳動杆	KNIFE BAR DRIVING LEVER BELL CRANK	1
47	809471	螺釘	SCREW	1
48	809480	螺母	NUT	1
49	809491	鉸鏈銷螺釘	HINGE SCREW	1
49-1	809491-1	螺帽	NUT	1
50	809500	螺母	NUT	1
51	809510	偏心銷	PIN	1
52	809520	鉸鏈銷	HING STUD	1
53	809531	螺釘	SCREW	1
54	809540	轉矩扭簧	TENSION SPRING	1
55	809550	棘輪爪(B)	RATCHET PAWL(B)	1
56	809560	棘輪爪(A)	RATCHET PAWL(A)	1
57	809570	拉簧	TENSION SPRING	1
58	809581	鉸鏈銷螺釘	HINGE SCREW	1
59	809590	傳動杆	DRIVING ROD	1
60	809600	拉簧	TENSION SPRING	1
61	809611	懸掛螺釘	SUSPENSION SCREW	1
62	809620	指形板	FINGER	1
63	809631	傳動杆定位架	DRIVING ROD POSITION BRACKET	1
64	809640	圍柱銷	POSITIONING PIN	1
65	809650	彈簧圍柱銷	SPRING PIN	1
66	809660	止推墊圈	THRUST WASHER	1
66-1	809660-1	鐵圈	IRON RING	1
67	809670	刀座固定架	KNIFE HOLDER POSITION BRACKET	1
68	809681	螺釘	SCREW	1
69	809690	墊圈	WASHER	1
70	809701	螺釘	SCREW	1

10. FEED CAM & TRIPPING SEGMENT COMPONENTS
送布凸輪關係

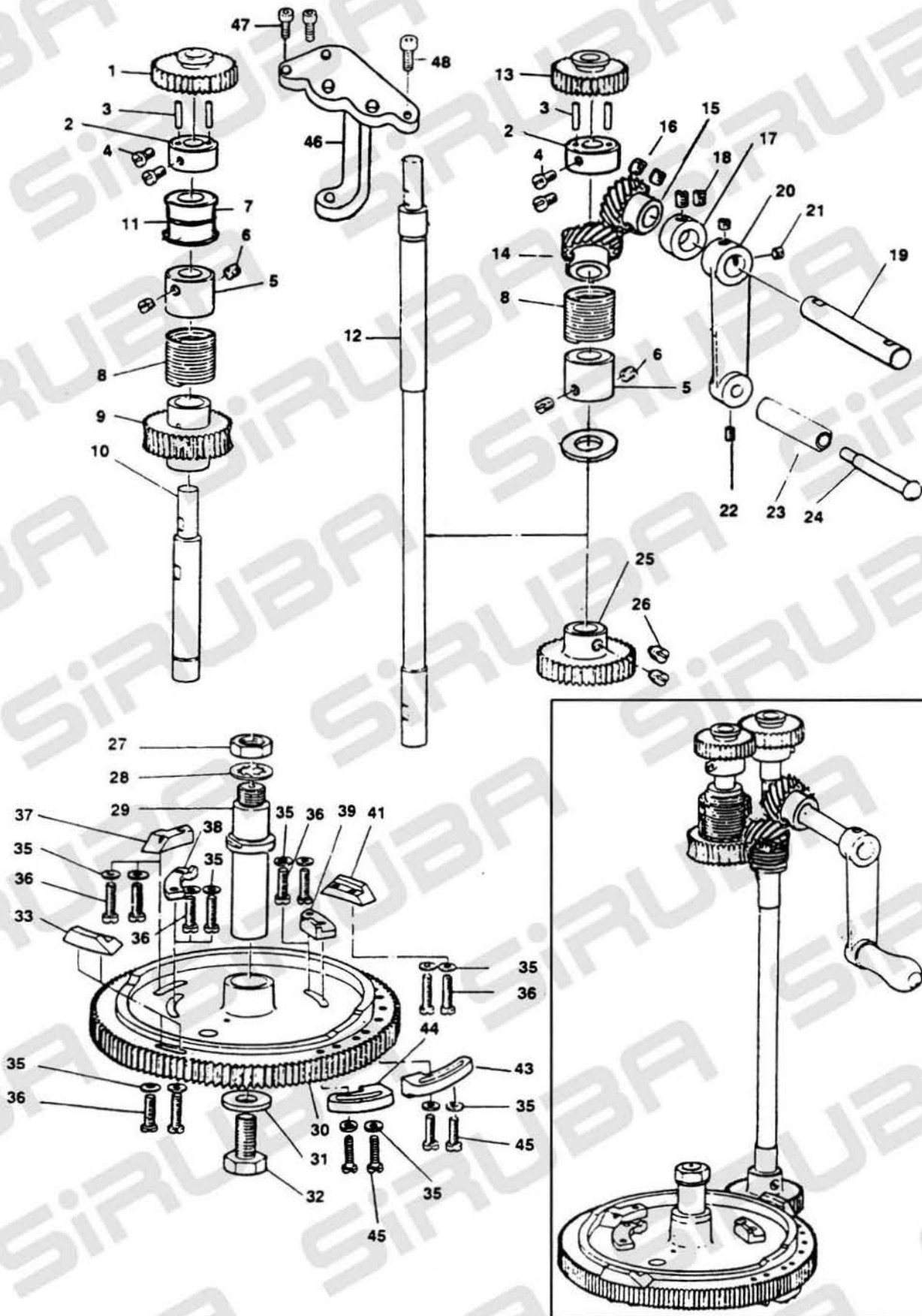

	Part No.	零件名稱	Description	Amt. 10 Req.
1	810010	直齒輪	SPUR GEAR	1
2	810020	直齒輪軸套	SPUR GEAR BUSHING	2
3	810030	直齒輪定位銷	SPUR GEAR BUSHING PIN	4
4	810041	螺釘	SCREW	4
5	810050	離合環	CLUTCH COLLAR	2
6	810061	螺釘	SCREW	4
7	810070	固定套管	POSITION BUSHING	1
8	810080	離合彈簧	CLUTCH SPRING	2
9	810090	送布凸輪傳動蝸輪	FEED CAM DRIVING WORM WHEEL	1
10	810100	傳動蝸輪軸	FEED CAM DRIVING WORM WHEEL SHAFT	1
11	810110	油氈	COLLAR	1
12	810120	送布凸輪傳動蝸輪	FEED CAM DRIVING SHAFT	1
13	810130	直齒輪	SPUR GEAR	1
14	810140	手搖曲柄左齒輪	HANDLE CRANK BEVEL GEAR,LEFT	1
15	810150	手搖曲柄右齒輪	HANDLE CRANK BEVEL GEAR,RIGHT	1
16	810161	螺釘	SCREW	2
17	810170	擋圈	THRUST COLLAR	1
18	810181	螺釘	SCREW	2
19	810190	手搖曲柄軸	HANDLE CRANK SHAFT	1
20	810200	手搖曲柄	HANDLE CRANK	1
21	810211	螺釘	SCREW	2
22	810221	螺釘	SCREW	1
23	810230	手柄	HANDLE SHAFT	1
24	810240	手柄軸	HANDLE SHAFT	1
25	810250	送布凸輪傳動蝸輪	FEED CAM DRIVING GEAR	1
26	810261	螺釘	SCREW	2
27	810270	螺母	NUT	1
28	810280	止推墊圈	THRUST WASHER	1
29	810290	送布凸輪軸	FEED CAM SHAFT	1
30	810300	送布凸輪	FEED CAM	1
31	810310	墊圈	WASHER	1
32	810321	螺釘	SCREW	1
33	810330	加固離合塊	BAR TRIPPING SEGMENT	1
34	-----			0
35	810350	墊圈	WASHER	14
36	810361	螺釘	SCREW	10
37	810370	切刀離合塊	KNIFE TRIPPING SEGMENT	1
38	810380	松線離合塊	TENSION RELEASE TRIPPING SEGMENT	1
39	810390	松線離合塊	TENSION RELEASE TRIPPING SEGMENT	1
40	-----			0
41	810410	加固離合塊	BAR TRIPPING SEGMENT	1
42	-----			0
43	810430	低速凸輪塊	LOW SPEED CAM	1
44	810440	止動凸輪塊	STOPPER CAM	1
45	810451	螺釘	SCREW	4
46	810460	齒輪定位架	GEAR POSITION BRACKET	1
47	810470	螺釘	SCREW	2
48	810481	螺絲	SCREW	1

11. STOP-MOTION COMPONENTS 遮斷裝置關係

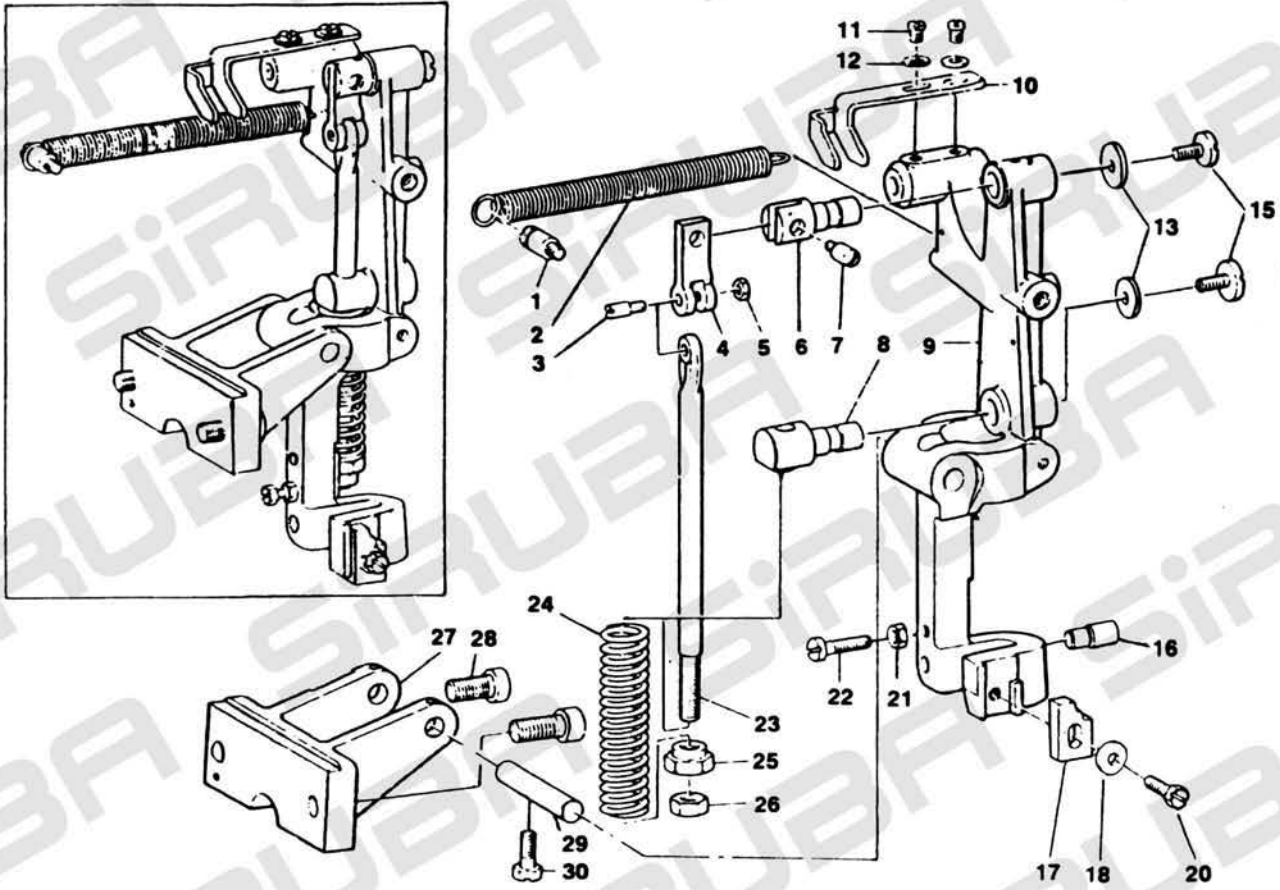

Part No.	零件名稱	Description	Amt. Req.	
1	811010	吊簧螺釘	SUSPENSION SCREW	1
2	811020	拉簧	TENSION SPRING	1
3	811031	止動連杆鉸鏈銷螺釘	STOP LINK ROD HINGE SCREW	1
4	811040	止動鉸接板	STOP LINK	1
5	811050	螺母	NUT	1
6	811060	止動連杆接頭	STOP LINK HINGE STUD	1
7	811071	止動鉸接板連接螺釘	STOP LINK CONNECTING SCREW	1
8	811080	止動連杆接頭	STOP LINK ROD HINGE STUD	1
9	811090	止動杠杆	STOP MOTION LEVER	1
10	811100	皮帶撥叉	BELT SHIFTER	1
11	811111	螺釘	SCREW	2
12	811120	墊圈	WASHER	2
13	811130	墊圈	WASHER	2
14	-----	-----	-----	0
15	811151	螺釘	SCREW	2
16	811160	限位銷	STOP PIN	1
17	811170	鎖定板	LATCH	1
18	811180	墊圈	WASHER	1
19	-----	-----	-----	0
20	811201	螺釘	SCREW	1
21	811210	螺母	NUT	1
22	811221	螺釘	SCREW	1
23	811230	止動連杆	STOP LINK ROD	1
24	811240	止動杆壓簧	STOP LINK ROD PRESSURE SPRING	1
25	811250	止動連杆螺母	NUT FOR STOPMLINK ROD	1
26	811260	螺母	NUT	1
27	811270	止動杠杆座	STOP MOTION LEVER BRACKET	1
28	811281	圓柱頭內六角螺釘	SCREW	2
29	811290	銷	PIN	1
30	811301	螺釘	SCREW	1

12. TRIPPING LEVER COMPONENTS
手動停止關係

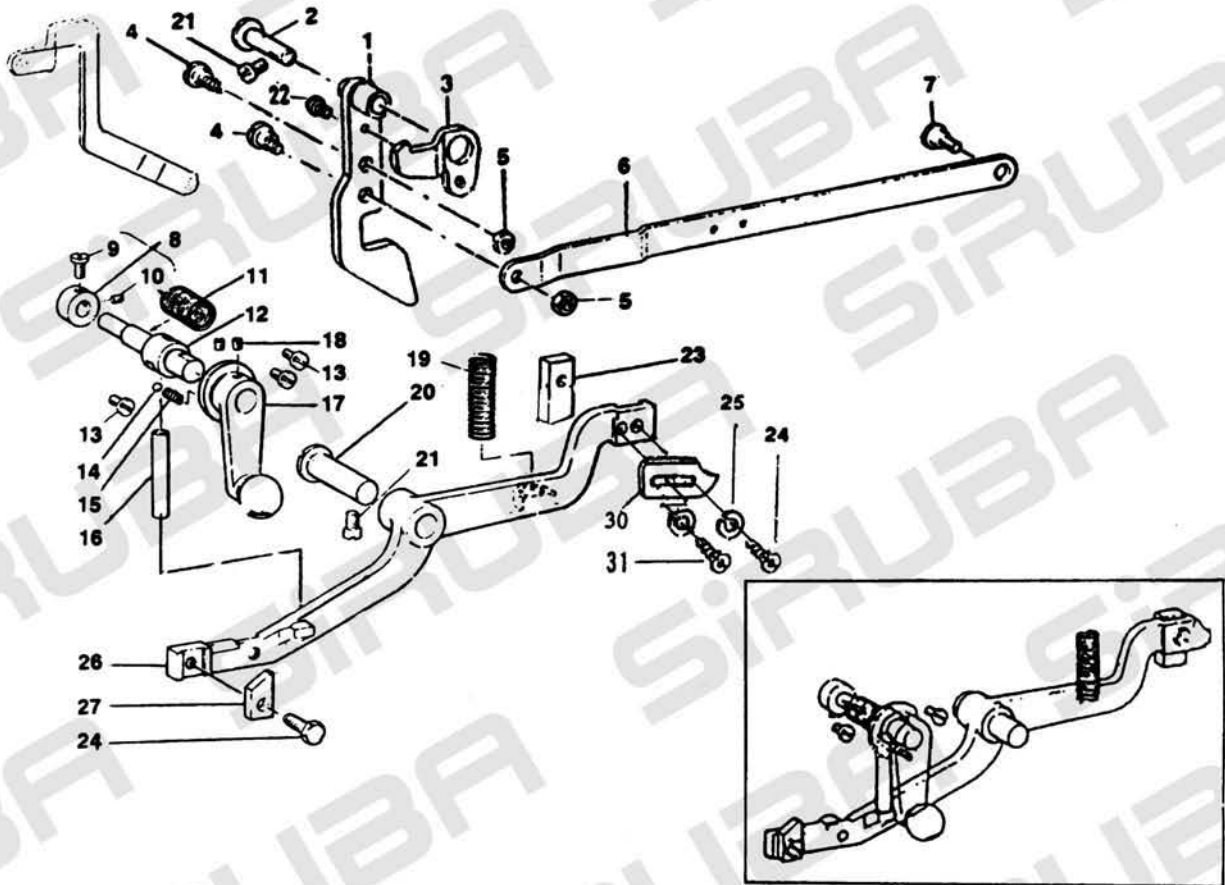

Part No.	零件名稱	Description	Amt. Req.	
1	812010	起動架	STARTING LINK	1
2	812020	鉸鏈銷	HINGE STUD	1
3	812030	安全底	SAFETY BASE	1
4	812041	偏心鉸鏈銷螺釘	HINGE SCREW	1
5	812050	螺母	NUT	2
6	812060	起動架拉杆	STARTING LINK DRIVING ROD	1
7	812071	鉸鏈銷螺釘	HINGE SCREW	1
8	812080	下軸後軸承擋圈	THRUST COLLAR	1
9	812091	螺釘	SCREW	1
10	812101	螺釘	SCREW	1
11	812110	曲軸轉矩彈簧	CRANK SHAFT TENSION SPRING	1
12	812120	手制動曲柄軸	HAND STOP CRANK SHAFT	1
13	812131	螺釘	SCREW	2
14	812140	鋼球	BALL	1
15	812150	曲柄壓簧	CRANK SHAFT PRESSURE SPRING	1
16	812160	手制動軸	HAND STOP ROD	1
17	812170	手柄	HAND STOP CRANK	1
18	812181	螺釘	SCREW	2
19	812190	運轉脫離杆壓簧	TRIPPING LEVER TENSION SPRING	1
20	812200	運轉脫離杆鉸鏈銷	TRIPPING LEVER HINGE PIN	1
21	812211	螺釘	SCREW	1
22	812221	螺釘	SCREW	0
23	812230	鎖定板	LATCH	1
24	812241	螺釘	SCREW	2
25	812250	輕型彈簧墊圈	SPRING WASHER	1
26	812260	運轉脫離杆	TRIPPING LEVER	1
27	812270	脫離爪	TRIPPING DOG	1
28	812280	滾輪	ROLLER	1
29	812291	鉸鏈銷螺釘	HINGE SCREW	1
30	812300	撥叉凸板	SHIFTER PLATE	1
31	812311	螺釘	SCREW	1

13. LIFTING LEVER & BOBBIN WINDER COMPONENTS
壓腳提升架、繞線器組

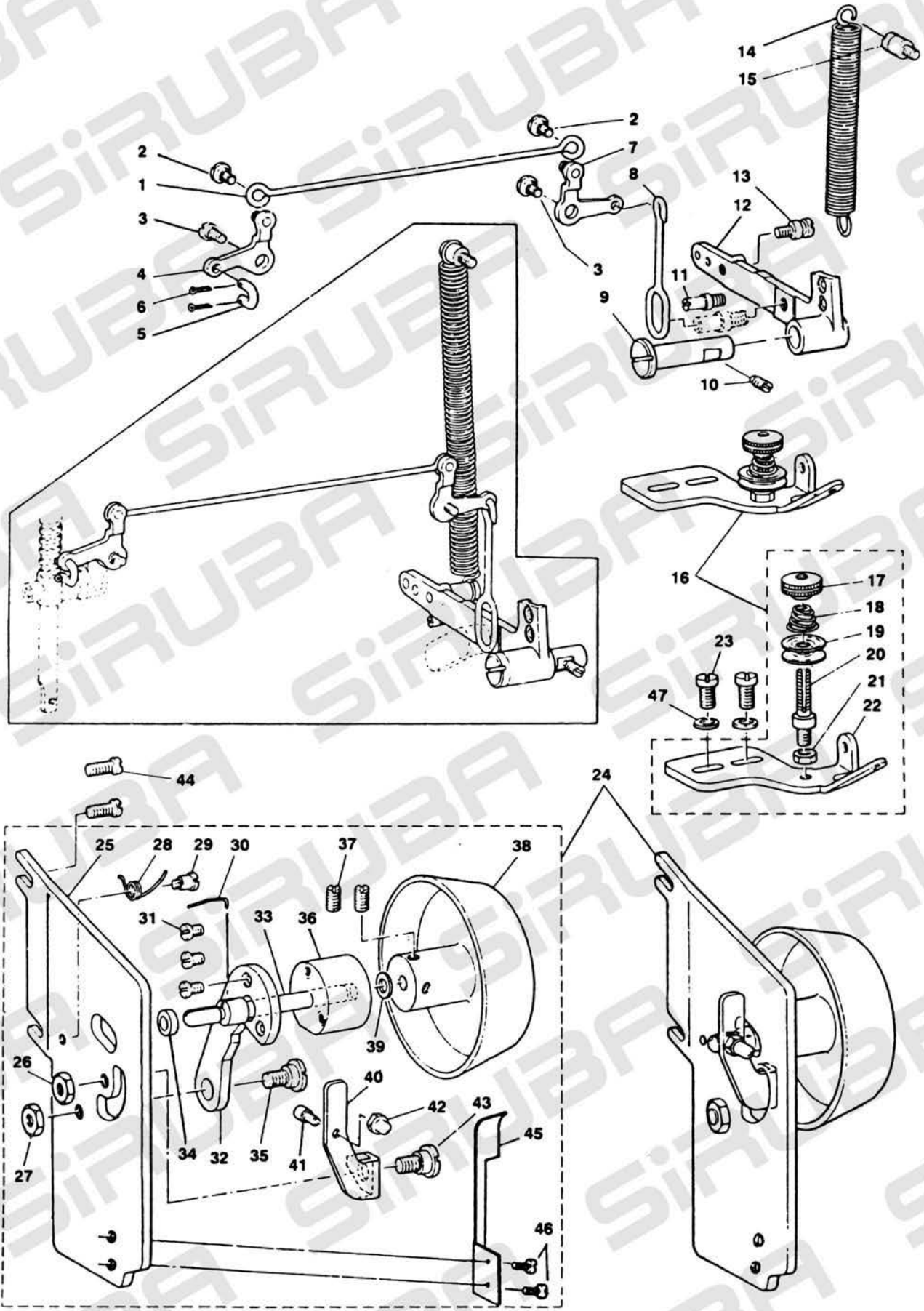

	Part No.	零件名稱	Description	Amt. 13 Req.
1	813010	壓棒提升長拉杆	PRESSER BAR LIFTING ROD, LONG	1
2	813020	螺釘	SCREW	2
3	813031	鉸鏈銷螺釘	HINGE SCREW	2
4	813040	前部杠杆	LEVER, FRONT	1
5	813050	鏈環	LINK	1
6	813060	開口銷	SPLIT PIN	2
7	813070	後部杠杆	LEVER, REAR	1
8	813080	壓棒提升拉杆	PRESSER BAR LIFTING ROD	1
9	813090	離合杆鉸鏈銷	TRIPPING LEVER HINGE PIN	1
10	813101	螺釘	SCREW	1
11	813110	提升杆限位螺釘	LIFTING LEVER STOPPER	1
12	813120	壓棒提升杆	PRESSER BAR LIFTING LEVER	1
13	813131	懸掛螺釘	SUSPENSION SCREW	1
14	813140	壓腳提升彈簧	PRESSER FOOT LIFTING SPRING	1
15	813151	吊簧螺釘	SUSPENSION SCREW	1
16	813160	繞線器過線組件	BOBBIN WINDER TENSION ASM.	1
17	813170	第一夾線螺母	BOBBIN WINDER TENSION NUT	1
18	813180	繞梭心線夾線彈簧	BOBBIN WINDER TENSION SPRING	1
19	813190	夾線盤	BOBBIN WINDER TENSION DISC	2
20	813200	繞梭心過線螺釘	BOBBIN WINDER TENSION POST	1
21	813210	螺母	NUT	1
22	813220	繞梭心線過線架	BOBBIN WINDER TENSION BRACKET	1
23	813231	螺釘	SCREW	2
24	813240	繞線器組件	BOBBIN WINDER ASM.	1
25	813250	繞線器板	BOBBIN WINDER BRACKET	1
26	813260	螺母	NUT	1
27	813270	螺母	NUT	1
28	813280	滿線跳板簧	BOBBIN WINDER SPRING	1
29	813291	鉸鏈銷螺釘	HINGE SCREW	1
30	813300	梭心固定簧	BOBBIN SET SPRING	1
31	813311	螺釘	SCREW	3
32	813320	帶輪軸座	PULLEY SHAFT BASE	1
33	813330	繞線器軸	BOBBIN WINDER SHAFT	1
34	813340	軸套	COLLAR	1
35	813351	鉸鏈銷螺釘	HINGE SCREW	1
36	813360	繞線器軸軸套	BOBBIN WINDER SHAFT BUSHING	1
37	813371	螺釘	SCREW	2
38	813380	繞線器傳動帶輪	BOBBIN WINDER DRIVING PULLEY	1
39	813390	墊圈	WASHER	1
40	813400	滿線跳板	BOBBIN WINDER TRIP LATCH	1
41	813411	調節螺釘	ADJUSTING SCREW	1
42	813420	調節螺母	ADJUSTING NUT	1
43	813431	鉸鏈銷螺釘	HINGE SCREW	1
44	813441	螺釘	SCREW	2
45	813450	彈簧板	SPRING BRACKET	1
46	813461	螺釘	SCREW	2
47	813470	墊圈	WASHER	2

14. THREAD TENSION COMPONENTS
夾線器關係

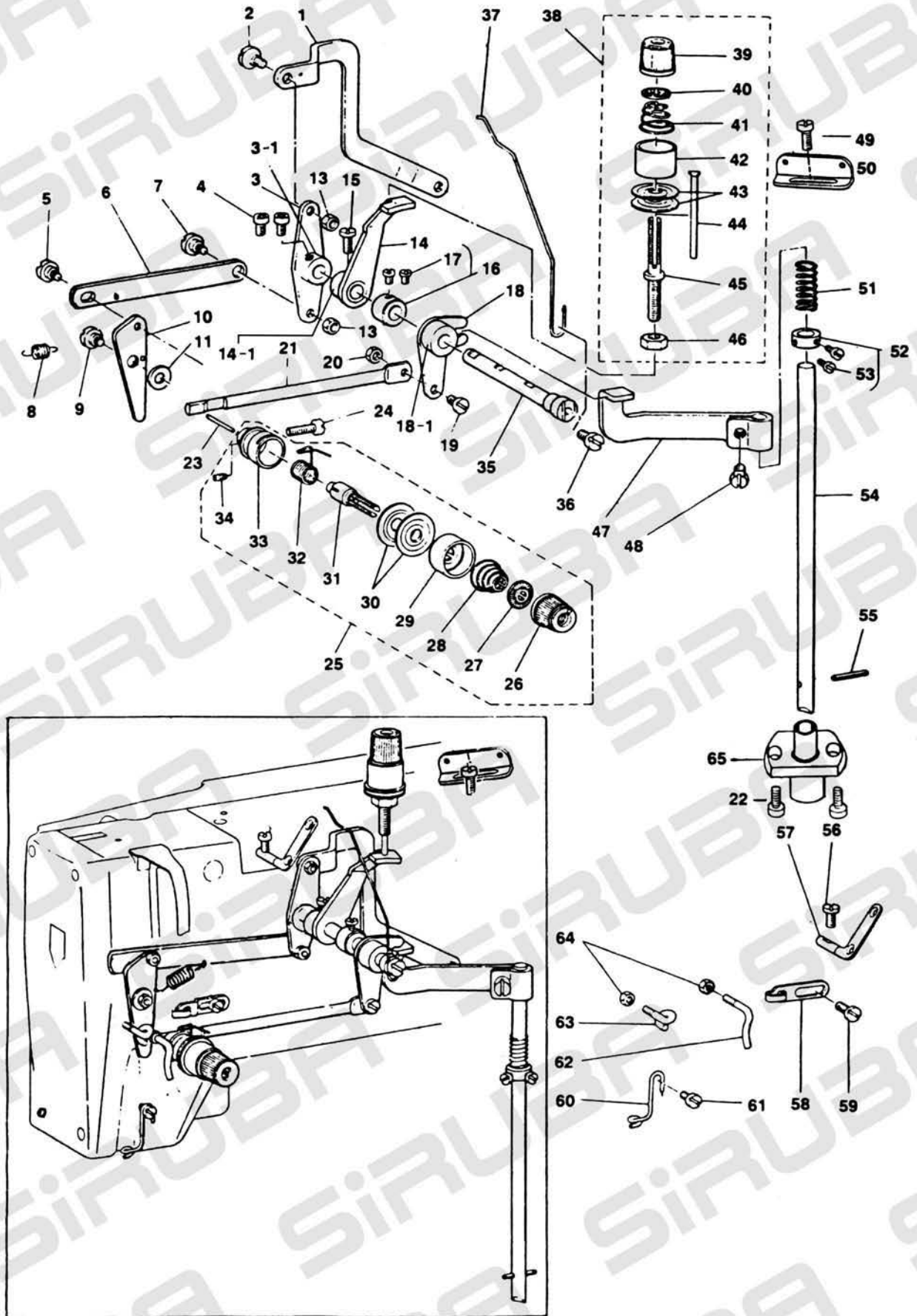

	Part No.	零件名稱	Description	Amt. 14 Req.
1	814010	松線連杆	TENSION RELEASE LINK	1
2	814021	鉸鏈銷螺釘	HINGE SCREW	1
3	814030	松線杆	TENSION RELEASE LEVER	1
3-1	814030-1	附件	ATTACHMENT	1
4	814041	螺釘	SCREW	2
5	814051	鉸鏈銷螺釘	HINGE SCREW	1
6	814060	連杆板	BLOCKING LINK	1
7	814071	鉸鏈銷螺釘	HINGE SCREW	1
8	814080	彈簧	BLOCKING ARM SPRING	1
9	814091	鉸鏈銷螺釘	HINGE SCREW	1
10	814100	杠杆板	BLOCKING ARM	1
11	814110	擋圈	WASHER	1
12	-----			0
13	814130	螺母	NUT	1
14	814140	松線杆	TENSION RELEASE LEVER	1
14-1	814140-1	附件	TENSION RELEASE LEVER ATTACHMENT	1
15	814151	螺釘	SCREW	1
16	814160	下軸後軸承擋圈	THRUST COLLAR	1
17	814171	緊定螺釘	SCREW	2
18	814180	松線杆曲柄	TENSION RELEASE LEVER CRANK	1
18-1	814180-1	附件	TENSION RELEASE LEVER CRANK ATTACHMENT	1
19	814191	鉸鏈銷螺釘	HINGE SCREW	1
20	814200	螺母	NUT	1
21	814210	松線杆	TENSION RELEASE ROD	1
22	814221	螺釘	SCREW	2
23	814230	松線釘	TENSION RELEASE PIN	1
24	814241	螺釘	SCREW	1
25	814250	夾線控制器2號組件	TENSION CONTROLLER NO.2 ASM.	1
26	814260	夾線螺母	TENSION NUT	1
27	814270	拉線鋼絲	THREAD PULLING WIRE	1
28	814280	壓線彈簧	TENSION SPRING	1
29	814290	管狀夾線板壓板	TENSION DISC PRESSER TUBE	1
30	814300	夾線盤	TENSION DISC	2
31	814310	面線第二過線螺釘	TENSION POST	2
32	814320	挑線簧	THREAD TAKE-UP SPRING	1
33	814330	過線螺釘座	TENSION POST SOCKET	1
34	814341	螺釘	SCREW	1
35	814350	松線杆軸	TENSION RELEASE LEVER SHAFT	1
36	814361	螺釘	SCREW	1
37	814370	拉線鋼絲	THREAD PULLING WIRE	1
38	814380	夾線控制器1號組件	TENSION CONTROLLER NO.1 ASM.	1
39	814390	真線螺母組件	TENSION NUT	1
40	814400	拉線鋼絲	TENSION DISC STOPPER	1
41	814410	真線彈簧	TENSION SPRING	1
42	814420	管狀真線壓板	TENSION DISC PRESSER TUBE	1
43	814430	夾線盤	TENSION DISC	2
44	814440	松線銷	TENSION RELEASE PIN	1
45	814450	面線第一過線螺釘	TENSION POST	1
46	814460	螺母	NUT	1
47	814470	松線臂	TENSION RELEASE ARM	1
48	814481	螺釘	SCREW	1
49	814491	螺釘	SCREW	1
50	814500	導線板	THREAD GUIDE PLATE	1
51	814510	彈簧	SPRING	1
52	814520	止推緊圈	THRUST COLLAR	1
53	814531	螺釘	SCREW	2
54	814540	松線杆	TENSION RELEASE ROD	1
55	814550	彈性圓柱銷	SPRING PIN	1
56	814561	螺釘	SCREW	1
57	814570	二眼線鉤	THREAD EYELET	1
58	814580	右線鉤	FRAME THREAD GUIDE	1
59	814591	螺釘	SCREW	1
60	814600	針杆過線鉤	NEEDLE BAR THREAD GUIDE	1
61	814611	螺釘	SCREW	1
62	814620	緊線鉤	TENSION THREAD GUIDE	1
63	814630	挑線過線鉤	TAKE-UP THREAD GUIDE	1
64	814640	螺母	NUT	2
65	814650	定位架	POSITION BRACKET	1

15. LUBRICATION MECHANISM COMPONENTS
給油裝置關係

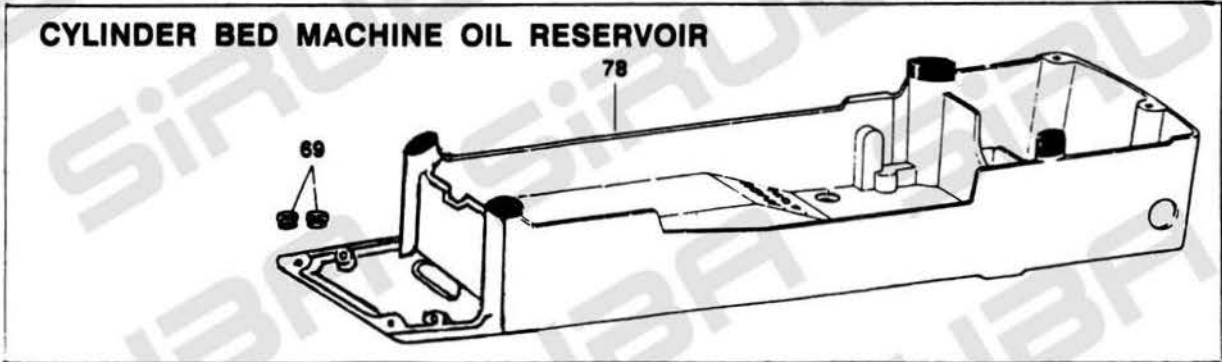
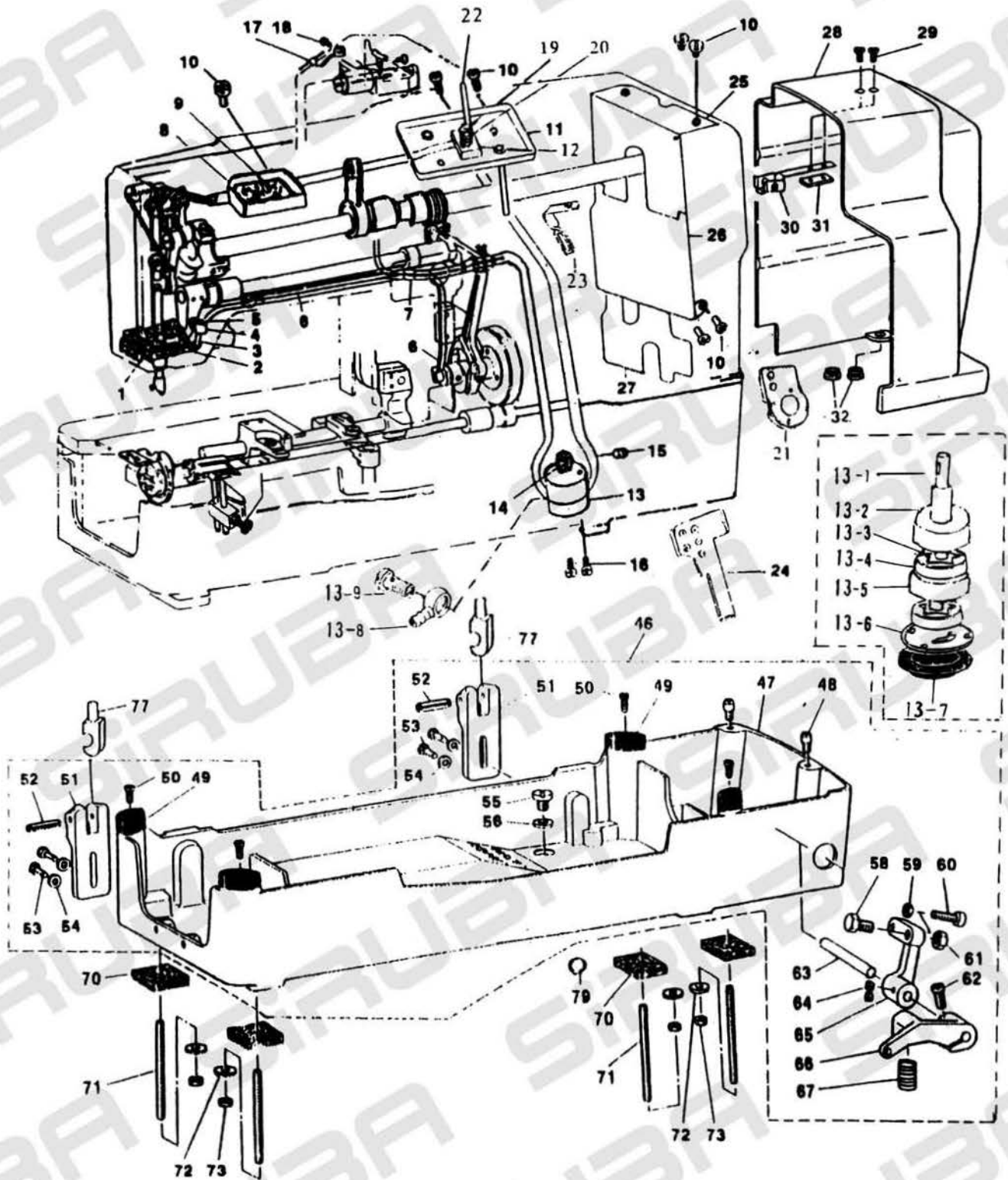

	Part No.	零件名稱	Description	Amt. 15 Req.
1	815010	回油壓板組件	OIL FELT HOLDER	1
2	815020	回油氈	OIL RETURN FELT	1
3	815030	回油管	OIL RETURN TUBE	1
4	815040	油管壓板	CABLE HOLDER	1
5	815051	螺釘	SCREW	1
6	815060	油芯	OIL WICK	1
7	815070	油管導架	PIPE GUIDE	1
8	815080	儲油器	OIL RECEIVER	1
9	815090	油氈	OIL FELT	1
10	815101	螺釘	SCREW	10
11	815110	盛油架	OIL RECEIVER	1
12	815120	調節潤滑螺釘座	OIL ADJUSTING SCREW BASE	1
13	815130	油泵完全座	OIL PUMP	1
13-1	815130-1	油泵軸	OIL PUMP SHAFT	1
13-2	815130-2	油泵殼(上)	OIL PUMP COVER (UP)	1
13-3	815130-3	油泵齒(內)	OIL PUMP GEAR (INNER)	2
13-4	815130-4	油泵齒(外)	OIL PUMP GEAR (OUTSIDE)	2
13-5	815130-5	油泵殼(下)	OIL PUMP COVER (LOWER)	1
13-6	815130-6	油泵板	OIL PUMP PLATE	1
13-7	815130-7	油泵網	OIL PUMP NET	1
13-8	815130-8	油管連接道	OIL PIPE CONNECTER	3
13-9	815131-9	配合螺絲	SCREW	3
14	815140	油泵驅動齒輪	OIL PUMP DRIVING WORM GEAR	1
15	815151	螺釘	SCREW	2
16	815161	螺釘	SCREW	2
17	815170	油氈導架	OIL FELT GUIDE	1
18	815181	螺釘	SCREW	1
19	815191	旋梭調節潤滑螺釘	HOOK OIL ADJUSTING SCREW	1
20	815200	彈簧	SPRING	1
21	815210	油泵板	OIL PUMP PLATE	1
22	815220	給油指示杆	OIL INDICATION LEVER	1
23	815230	油管固定板(小)	OIL PIPE FIXED PLATE (SMALL)	1
24	815240	油管固定板(大)	OIL PIPE FIXED PLATE (BIG)	1
25	815251	油罩	OIL SHIELD	1
26	815260	油罩	OIL SHIELD	1
27	815271	油罩	OIL SHIELD	1
28	815280	皮帶罩	BELT GUARD	1
29	815291	螺釘	SCREW	2
30	815300	皮帶罩安裝夾	BELT GUARD LATCH	1
31	815310	底部導板	BOTTOM GUIDE	1
32	815320	橡膠軸套	RUBBER BUSHING	1
46	815460	底座組件	MACHINE BASE ASM.	1
47	815470	油池	OIL RESERVOIR	1
48	815480	導銷	GUIDE PIN	2
49	815490	橡膠墊	RUBBER CUSHION	4
50	815501	螺釘	SCREW	4
51	815510	鉸鏈座	HINGE HOLDER	2
52	815520	彈性圓柱銷	PIN	2
53	815531	螺釘	SCREW	4
54	815540	墊圈	WASHER	4
55	815551	螺釘	SCREW	1
56	815560	密封墊	OIL DRAIN CAP GASKET	1
58	815581	螺釘	SCREW	1
59	815590	螺母	NUT	1
60	815601	止動螺釘	STOP SCREW	1
61	815610	螺母	NUT	1
62	815621	螺釘	SCREW	1
63	815630	起動架軸	STARTING LINK SHAFT	1
64	815641	螺釘	SCREW	2
65	815650	起動架	STARTING LINK	1
66	815660	起動杆	STARTING LEVER	1
67	815670	起動杆壓簧	STARTING LEVER PRESSURE SPRING	1
68	815680	撥叉傳動銷	SHIFTER DRIVING PIN	1
69	815690	橡膠軸套	RUBBER BUSHING	2
70	815700	底座氈墊	MACHINE BASE FELT PAD	4
71	815710	底座螺絲	MACHINE BASE SCREW STUD	4
72	815720	墊圈	WASHER	4
73	815730	螺母	NUT	4
77	815770	連接銷	CONNECTION STUD	2
78	815780	油池	OIL RESERVOIR	1

16. SPEED TRANSMITTER COMPONENTS 減速機關係

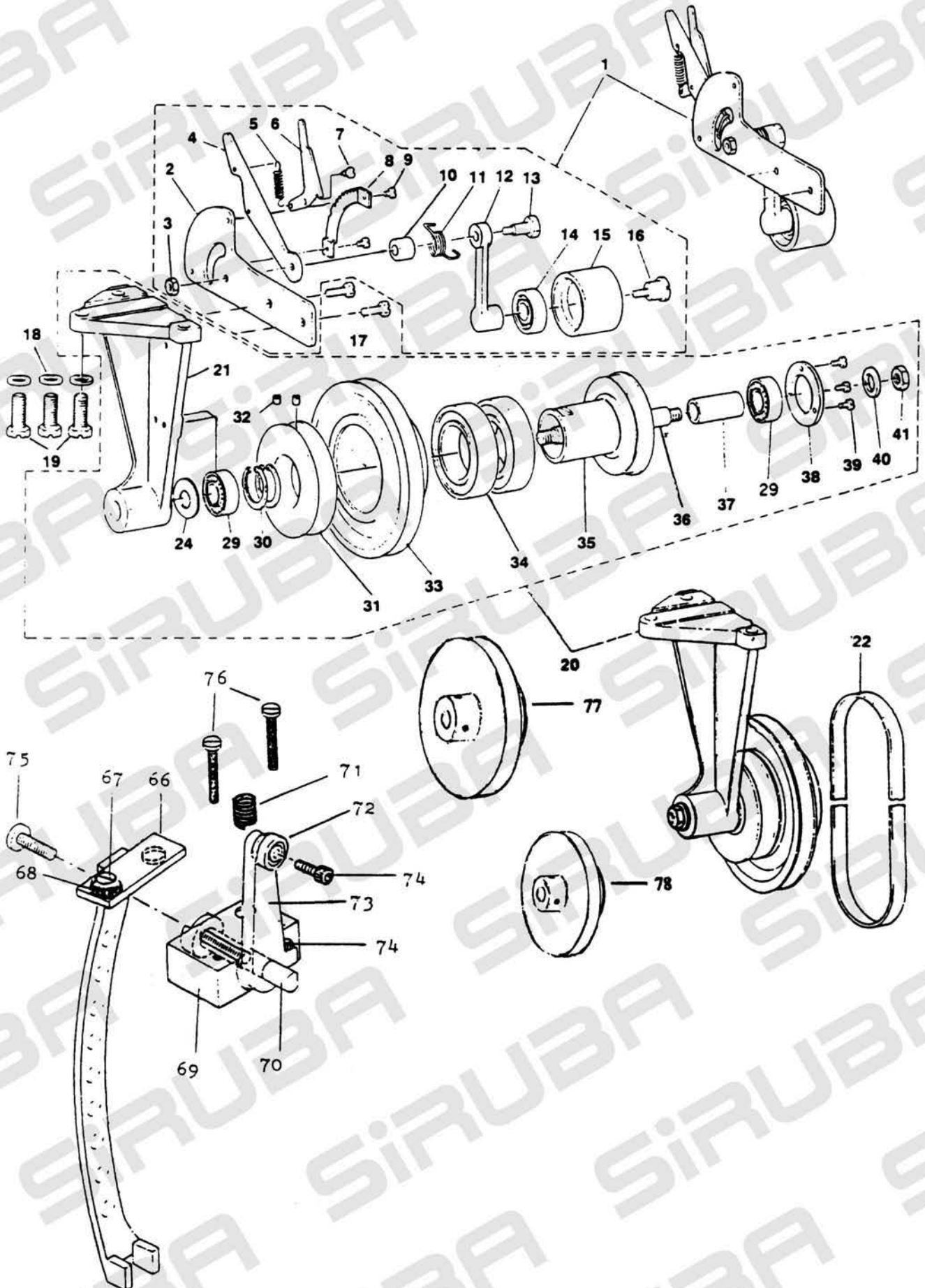

Part No.	零件名稱	Description	Amt. 16 Req.
1	816010	皮帶張緊輪座組件	TENSION PULLEY ASM. 1
2	816020	皮帶張緊輪座	TENSION PULLEY BRACKET 1
3	816030	螺母	NUT 1
4	816040	張杆	TENSION LEVER 1
5	816050	定位爪拉簧	NIPPER BAR ACTUATING LEVER SPRING 1
6	816060	定位爪	FIXING PAWL 1
7	816071	鉸鏈銷螺釘	HINGE SCREW 1
8	816080	棘爪	RATCHET 1
9	816091	緊定螺釘	SCREW 2
10	816100	隔套	LEVER COLLAR 1
11	816110	轉矩彈簧	TENSION SPRING 1
12	816120	張緊輪連杆	TENSION PULLEY LINK 1
13	816131	鉸鏈銷螺釘	HINGE SCREW 1
14	816140	單列向心球軸承	BEARING 1
15	816150	皮帶張緊輪	TENSION PULLEY 1
16	816161	鉸鏈銷螺釘	HINGE SCREW 1
17	816171	螺釘	SCREW 2
18	816180	墊圈	WASHER 3
19	816191	螺釘	SCREW 3
20	816200	撥叉傳動組件	SHIFTER DRIVING ASM. 1
21	816210	變速器支架	SPEED TRANSMITTER BRACKET 1
22	816220	傳動膠帶	BELT 1
23	-----		0
24	816240	增速帶輪軸承墊圈	HIGH SPEED WASHER FOR BEARING 1
25	816250	止動螺釘組件	STOP SCREW ASM. 1
26	816260	螺母	NUT 1
27	816270	撥叉限位器支架	SHIFTER STOPPER BRACKET 1
28	816281	螺釘	SCREW 2
29	816290	單列向心球軸承	BEARING 2
30	816300	擋圈	RETAINING RING 2
31	816310	增速帶輪	ACCELERATING PULLEY 1
32	816321	緊定螺釘	SCREW 2
33	816330	高速帶輪	HIGH-SPEED PULLEY 1
34	816340	單列向心球軸承	BEARING 2
35	816350	低速帶輪	LOW-SPEED PULLEY 1
36	816360	變速軸	SPEED TRANSMITTER SHAFT 1
37	816370	隔套	SLEEVE 1
38	816380	軸承壓緊環	BEARING PRESSER 1
39	816391	螺釘	SCREW 3
40	816400	墊圈	WASHER 1
41	816410	螺母	NUT 1
66	816660	變速撥叉	SPEED TRANSMITTER SHIFTER 1
67	816671	螺絲	SCREW 1
68	816680	螺母	NUT 1
69	816690	撥叉底座	SHIFTER BASE 1
70	816700	鉸鏈銷軸	HINGE SHAFT 1
71	816710	撥叉壓簧	SHIFTER TENSION SPRING 1
72	816720	軸承	BEARING 1
73	816730	撥叉傳動臂	SHIFTER DRIVING ARM 1
74	816741	螺絲	SCREW 2
75	816751	螺絲	SCREW 1
76	816761	螺絲	SCREW 2
77	816770	馬達輪	MOTOR PULLEY 1
78	816780	馬達輪	MOTOR PULLEY 1 (FOR KBH-783V, 784V USE)

17. EXCLUSIVE PARTS FOR 784
784專用零件

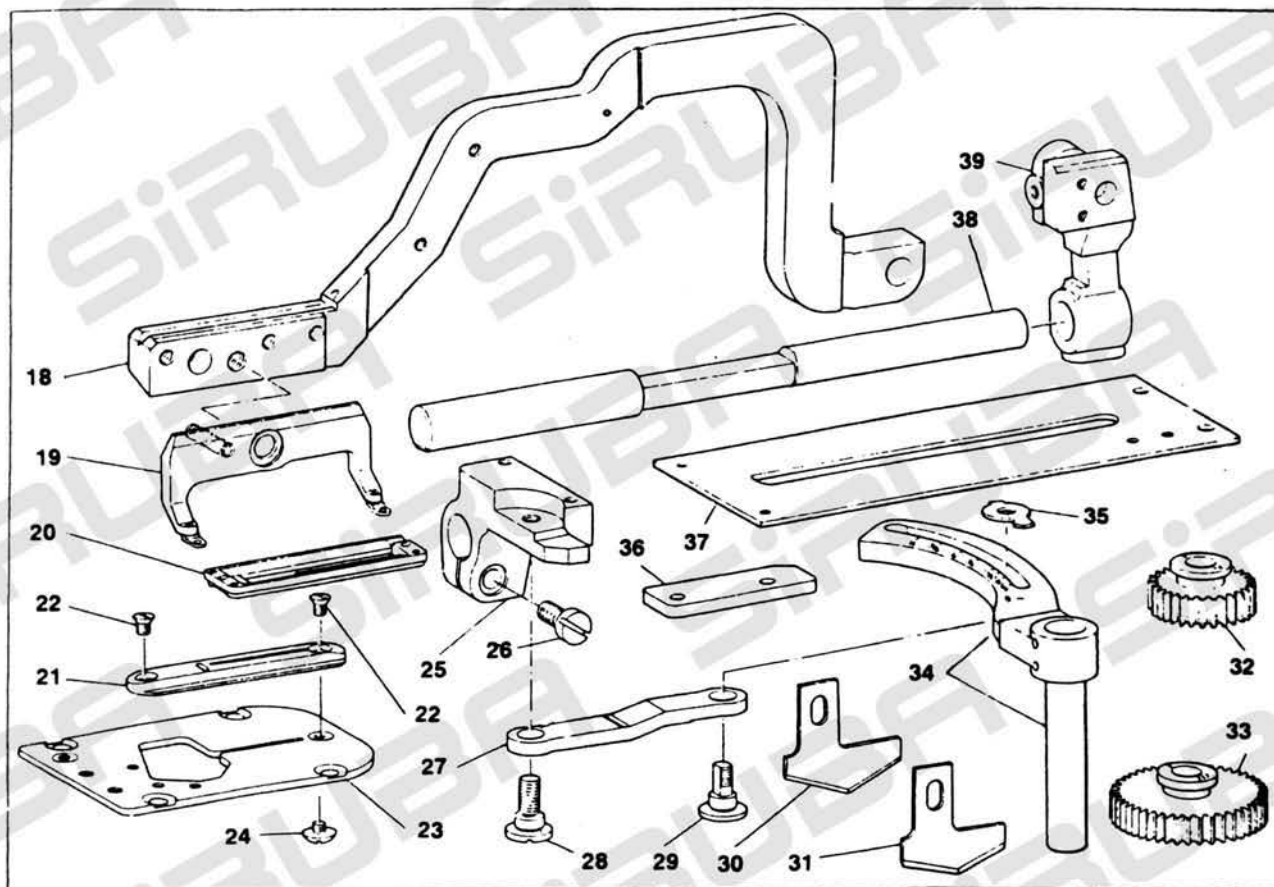

Part No.	零件名稱	Description	Amt. Req.
1	-----		0
17	-----		0
18	817180	布料夾 WORK CLAMP ARM	1
19	817190	壓腳 WORK CLAMP CHECK HOLDER	1
20	817200	壓腳板組件 WORK CLAMP CHECK	1
21	817210	針板 THROAT PLATE	1
22	817221	螺絲 SCREW	2
23	817230	針板座 THROAT PLATE BASE	1
24	817241	螺釘 SCREW	1
25	817250	送料支架 WORK CLAMP ARM BRACKET	1
26	817261	螺釘 SCREW	1
27	817270	送料支架連杆 WORK CLAMP CARRIER PITMAN	1
28	817281	螺釘 SCREW	1
29	817291	調節送料長度鉸鏈銷螺釘 FEED ADJUSTING SCREW	1
30	817300	刀 KNIFE 1-1/2"	1
31	817310	刀 KNIFE 1-3/8"	1
32	817320	直齒輪 SPUR GEAR (74)	1
33	817330	直齒輪 SPUR GEAR (252)	1
34	817340	調節送料長度刻度盤組件 LENGTH REGULATING ARM ASM.	1
35	817350	調節送料長度軸導板 LENGTH REGULATING SHAFT GUIDE	1
36	817360	送布拖板支架導塊 WORK CLAMP ARM BRACKET GUIDE	1
37	817370	送布拖板 WORK CLAMP CARRIER	1
38	817380	壓腳臂滑杆 WORK CLAMP ARM SLIDE ROD	1
39	817390	托架 WORK CLAMP ARM BEARING BRACKET	1

18. EXCHANGING PARTS
交換零件

① 小齒輪 SMALL GEAR		② 大齒輪 LARGE GEAR		
				
SET	針數 STITCH NO.	件號 PART NO.	針數 STITCH NO.	件號 PART NO.
E	74	81801E	252	81802E
G	83	81801G	225	81802G
J	100	81801 J	190	81802 J
K	105	81801K	180	81802K
L	110	81801L	170	81802L
N	123	81801N	152	81802N





③ 刀片 KNIFE			④ 壓腳 WORD CLAMP CHECK		⑤ 針板 THROAT PLATE		⑥ 導片 GUIDE	
								
NO.	規格 SIZE (mm)	件號 PART NO.	件號 PART NO.		件號 PART NO.		件號 PART NO.	
1	1/4" (6.3)	818301	81841A 81841B (25.4mm)		818501 (31.7mm)		818601 (25.4mm)	
2	3/8" (9.5)	818302						
3	1/2" (12.7)	818303						
4								
5	5/8" (15.8)	818305						
6	3/4" (19.0)	818306						
7	7/8" (22.2)	818307						
8	1" (25.4)	818308						
9	1-1/4" (31.7)	818309	81842A (31.7mm) 81842B		818502 (38.1mm)		818602 (31.7mm)	
10			81843A (38.1mm) 81843B				818602 (38.1mm)	
11	1-1/2" (38.1)	818311						

TABLE CUT-OUT OF BH780-T1

高速機械式鎖眼機桌板圖
 TABLE CUT-OUT FOR BH780780
 單位/UNIT:mm
 所有尺寸公差/DIFFERENCE:±2
 BH780-T1長度(L):1200/重量
 所有孔均倒C0.5
 全封邊灰格紋光塑面台板

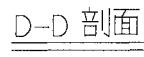
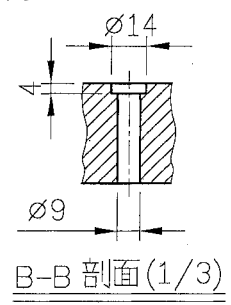
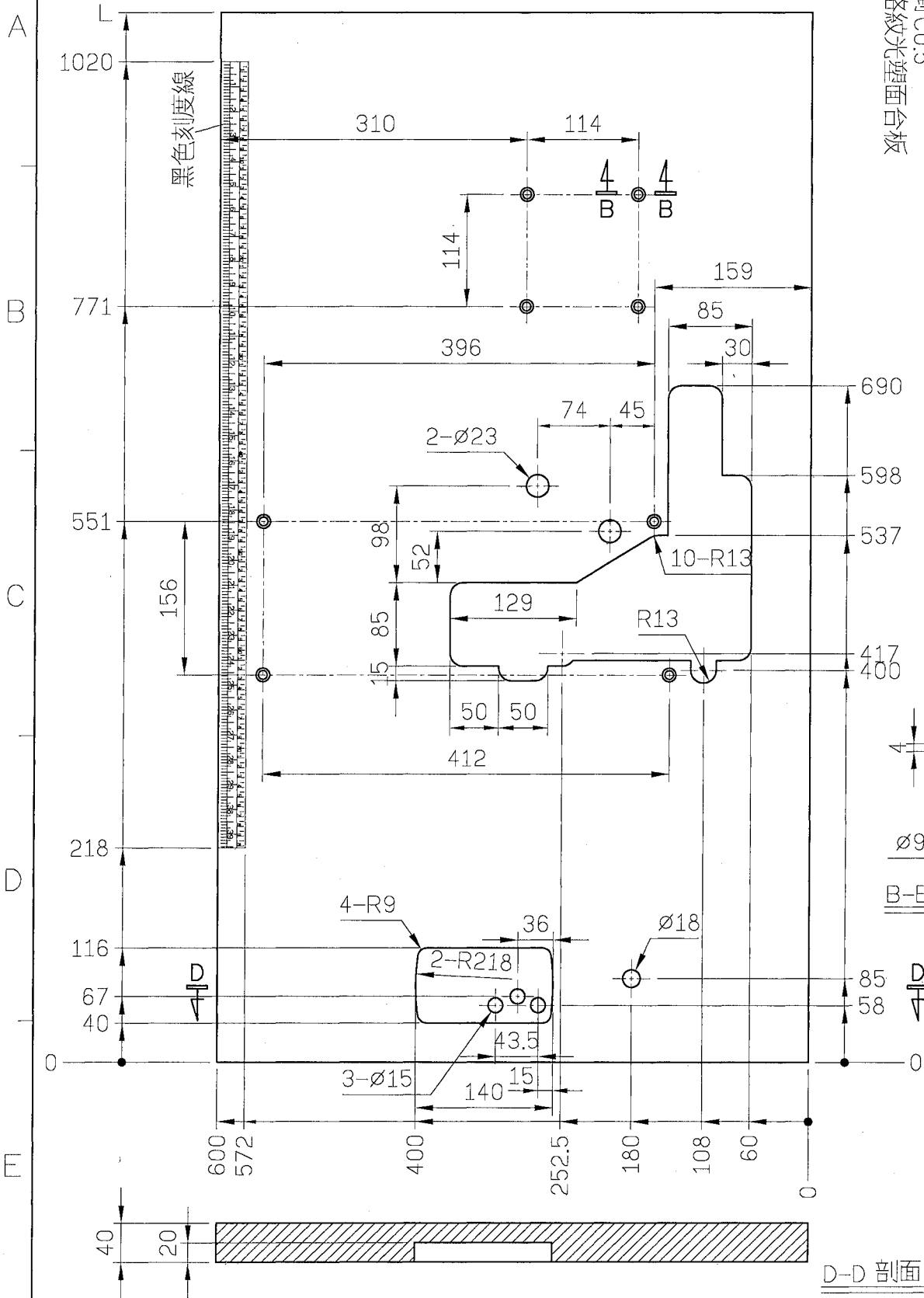

For 高機

07/08/25