

MANUAL NO.  
PRT9311

ILLUSTRATED PARTS LIST

STYLES

SP151H829M032  
SP151H830M032  
SP151H829M040  
SP151H830M040  
SP161S800M032  
SP161S800M040  
SP161S800M048C  
SP161S900M032C  
SP161S900M040C  
SP161S900M048C  
SP161H829M032  
SP161H830M032  
SP161H829M040  
SP161H830M040  
SP172S800MAAC  
SP172S800MACC  
SP172S800MADC  
SP172S900MACC  
SP172S900MADC  
SP172S900MAEC  
SP172S800MBDC  
SP172S900MBDC  
SP172S900HAC  
SP172S900HAD  
SP172S900HAE  
SP172S900HBD  
SP172S900HBE

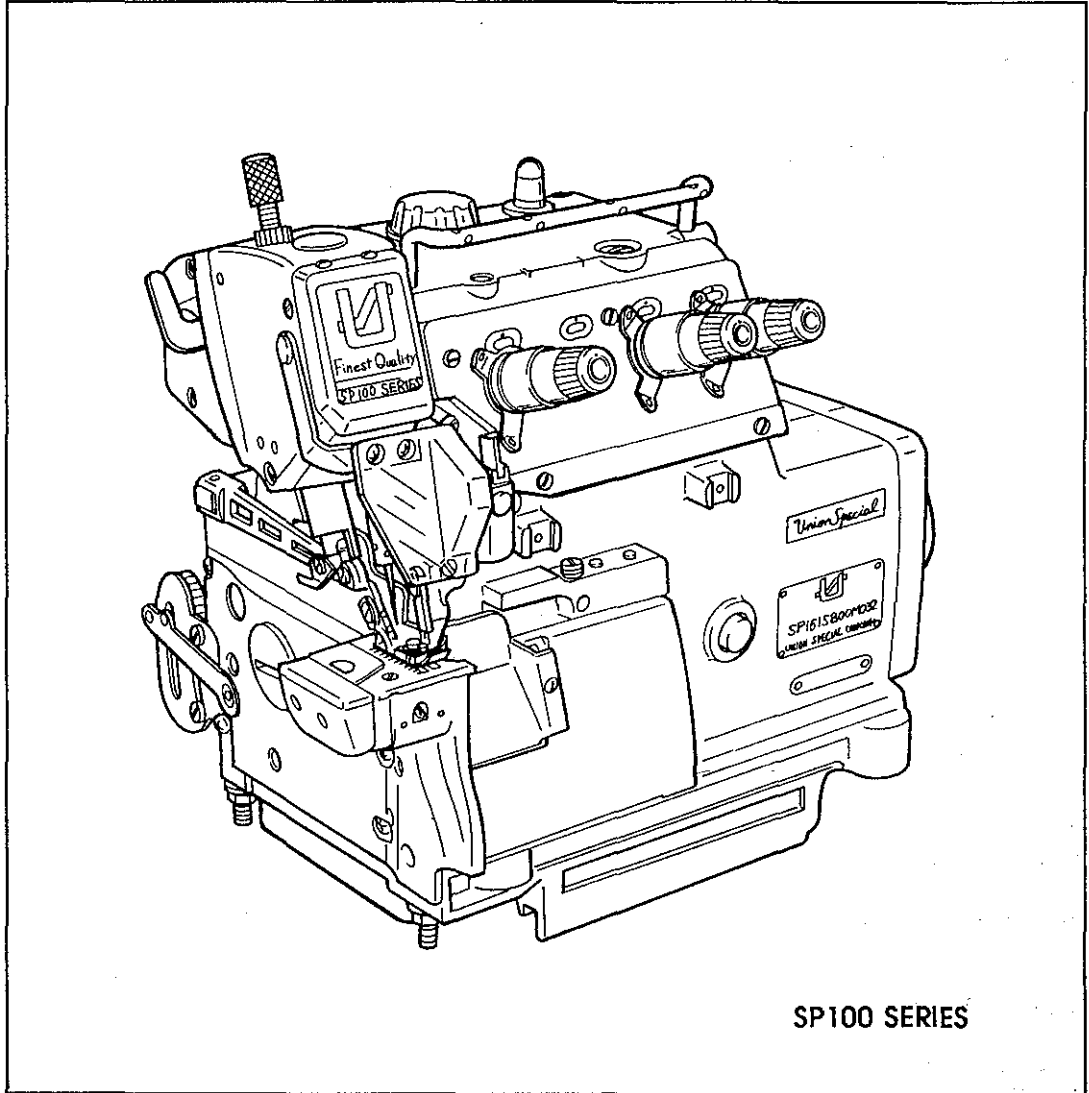

SP100 SERIES



*Union Special*  
INDUSTRIAL SEWING EQUIPMENT

29158607  
No.0984-00

# Manual No. PRT9311 Illustrated Parts List for the SP100 Series Machines

---

---

First Edition Copyright 1993

By

Union Special Corporation Rights Reserved In All Countries

Printed in Japan October 1993

---

---

## PREFACE

This parts manual has been prepared to assist you in locating individual parts or assemblies on the SP100 Series machines. It can be used in conjunction with Union Special Adjusting manual INS9310.

It is the desire of Union Special that each machine run at its optimum performance. Parts listed in this manual are designed specifically for your machine and are manufactured with utmost precision to assure long lasting service.

This manual has been comprised on the basis of available information. Changes in design and/or improvements may incorporate a slight modification of configuration in illustrations or part numbers.

On the following pages are illustrations and terminology used in describing the parts used on the SP100 Series machines.

---

---

## SAFETY RULES



### General Operating Directions

The sewing machines described in this manual are prohibited from being put into service until it has been ascertained that the sewing units, in which these sewing machines will be built-in have conformed with the EC Council Directives (89/392/EEC, Annex II B).

1. Before putting the machines described in this manual into service, carefully read the instructions. The starting of each machine is only permitted after taking notice of the instructions and by qualified operators.

**IMPORTANT!** Before putting the machine into service, also read the safety rules and instruction from the motor supplier.

2. Observe the national safety rules valid for your country.
3. Each machine is only allowed to be used as foreseen. The foreseen use of the particular machine is described in paragraph "STYLES OF MACHINES" of this manual. Another use, going beyond the description, is not as foreseen.
4. All safety devices must be in position when the machine is ready for work or in operation. Operation of the machine without the appertaining safety devices is not allowed.
5. The following safety devices are components of the sewing machines: Fingerguard, needle lever eyelet guard, needle bar guard, needle break protection shield and handwheel-belt guard.
6. When gauge parts are exchanged (e.g. needle, presser foot, needle plate, feed dog and bobbin) during threading, when the operator leaves the workplace, and during service work, the machine must be isolated from the main power by switching off the main switch or disconnecting the main plug. On mechanically operated clutch motors without a start inhibitor it is necessary to wait until the motor has stopped.

7. Wear safety glasses.
8. In case of machine conversions and changes all valid safety rules must be considered. Conversions and changes are made at your own risk.
9. Commissioning of the sewing head is prohibited until such time as the entire sewing unit is found to comply with EC regulations.
10. The warning hints in the instructions are marked with one of these two symbols:



Items require special attention



Danger of injury to operative or service staff

Be sure to observe and adhere to these indications and to the generally applicable regulations.

#### Special Operating Directions

11. For the following the machine has to be disconnected from the power supply by turning off the main switch or by pulling out the main plug:
  - 11.1 For threading needle(s), looper, spreader etc.
  - 11.2 For replacing sewing tools such as needle, presser foot, throat plate, looper, spreader, feed dog, needle guard, folder, fabric guide etc.
  - 11.3 When leaving the workplace and when the workplace is unattended.
  - 11.4 For maintenance work.
  - 11.5 When using clutch motors without actuation lock, wait until the motor is stopped totally.

#### General Maintenance Directions

12. Maintenance, repair and conversion work (see item 8) must be done only by trained technicians or special skilled personnel under consideration of the instructions.
13. Any work on the electrical equipment must be done by an electrician or under direction and supervision of special skilled personnel.

#### Special Maintenance Directions

14. Work on parts and equipment under electrical tension is not permitted. Permissible exceptions are described in the applicable sections of standard sheet DIN VDE 0105.
15. Before doing maintenance and repair work on the pneumatic equipment, the machine has to be disconnected from the compressed air supply. In case of existing residual air pressure after disconnecting from compressed air supply (e.g. pneumatic equipment with air tank), the pressure has to be removed by bleeding.

Exceptions are only allowed for adjusting work and function checks done by special skilled personnel.

#### Standards

17. The sewing machines described in this manual are built according to the following standards:
  - EN292-2 Safety of machinery-basic concepts, general principles for design.
  - IEC204-3-1/EN60204-3-1 Electrical equipment of industrial machines. Part 3: Particular requirements for sewing machines, units and systems.

Section 1 to 16 (page 1 to 28) of this parts list cover the machine of model Nos. SP161S800M040 and SP172S900MADC.

For subclass machine, refer to Section 18 Subclasses (page 30).

このパーツリストの1～16項目は標準機種 (SP161S800M040, SP172S900MADC)を示しています。その他サブクラスは18項目を御覧ください。

## CONTENTS

### 目次

1. FRAME COMPONENTS(1) .....	1
フレーム関係 (1)	
2. FRAME COMPONENTS(2) .....	3
フレーム関係 (2)	
3. CRANKSHAFT COMPONENTS .....	5
主軸関係	
4. NEEDLE DRIVING SHAFT COMPONENTS .....	7
針駆動軸関係	
5. FEED MECHANISM COMPONENTS(1) .....	9
送り関係(1)	
6. FEED MECHANISM COMPONENTS(2) .....	11
送り関係(2)	
7. UPPER & LOWER LOOPER COMPONENTS .....	13
上ルーパ、下ルーパ関係	
8. PRESSER FOOT COMPONENTS(1) .....	15
押え関係 (1)	
9. PRESSER FOOT COMPONENTS(2) .....	17
押え関係 (2)	
10. THREAD TENSION COMPONENTS .....	19
糸調子関係	
11. LOWER KNIFE COMPONENTS .....	21
下メス関係	
12. UPPER KNIFE COMPONENTS .....	23
上メス関係	
13. NEEDLE COOLING MECHANISM COMPONENTS .....	24
針冷却装置関係	
14. LUBRICATION MECHANISM COMPONENTS .....	25
給油装置関係	
15. SEMI-SUNKEN TYPE TABLE COMPONENTS .....	27
卓上式テーブル関係	

16. THREAD STAND COMPONENTS .....	28
糸立装置関係	
17. SPECIAL ORDER PARTS COMPONENTS .....	29
特別注文部品関係	
18. SUBCLASSES .....	30
サブクラス	
(1) SP161S800M032 .....	30
(2) SP161S800M048C .....	30
(3) SP161S900M032C .....	30
(4) SP161S900M040C .....	31
(5) SP161S900M048C .....	31
(6) SP151H8ΔΔM032 .....	32
(7) SP151H8ΔΔM040 .....	32
(8) SP161H8ΔΔM032 .....	33
(9) SP161H8ΔΔM040 .....	33
(10) SP172S800MAAC .....	34
(11) SP172S800MACC .....	34
(12) SP172S800MADC .....	35
(13) SP172S900MACC .....	35
(14) SP172S900MAEC .....	36
(15) SP172S800MBDC .....	36
(16) SP172S900MBDC .....	36
(17) SP172S900HAC .....	37
(18) SP172S900HAD .....	37
(19) SP172S900HAE .....	37
(20) SP172S900HBD .....	38
(21) SP172S900HBE .....	38
NUMERICAL INDEX PARTS .....	39
索引	

# 1. FRAME COMPONENTS(1)

フレーム関係 (1)

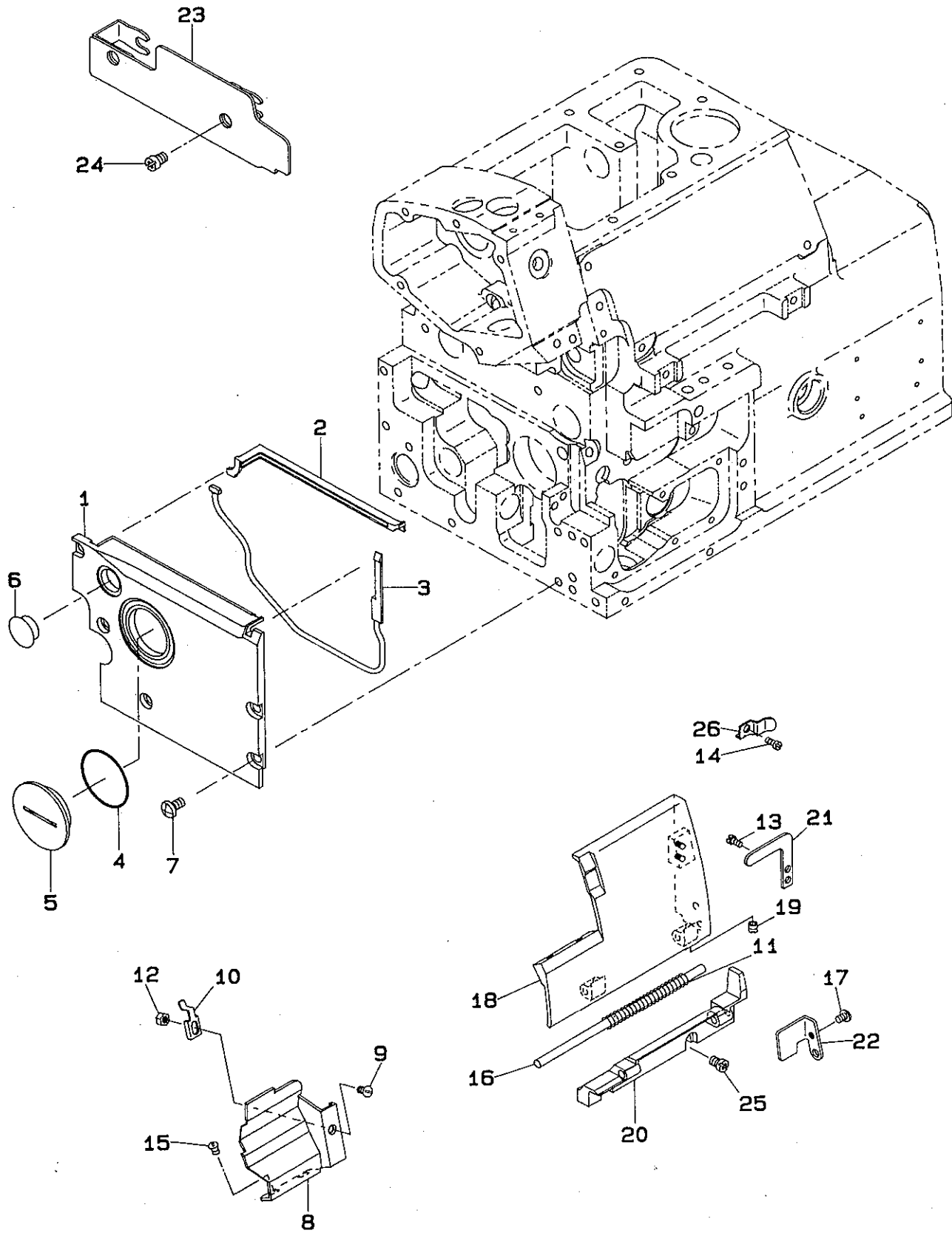

REF.NO	NOTE	PART NO.	DESCRIPTION	ヒンメイ	Qty
1		122-00200	FEED MECHAISM COVER	オクリフタ	1
2		122-00309	GASKET A	オクリフタ ハッキンA	1
3		122-00408	GASKET B	オクリフタ ハッキン B	1
4		RO-3152001-00	RUBBER RING	Oリング	1
5		122-00507	COVER	オクリ チョウセツアナ フタ	1
6		TA-1450404-RO	RUBBER PLUG D=14.5 L=4	トメセン D=14.5 L=4	1
7		SS-4120915-SP	SCREW 3/16-28 L=9	ナハネジ 3/16-28 L=9	5
8		122-29100	CHIP GUARD COVER	ヌノクス カハ	1
9		SS-2090520-SL	SCREW 9/64-40 L=5	マルサラネジ 9/64-40 L=5	1
10		121-01507	CLOTH WASTE COVER STOPPER	ヌノクス カハ ストッパ	1
11		B1140-716-000	SPRING	ルハカハ ハネ	1
12		NS-6090310-SN	NUT 9/64-40	ロツカクナツ 9/64-40	1
13		SS-7090530-SP	SCREW 9/64-40 L= 4.5	マルヒラネジ 9/64-40 L=4.5	2
14		SS-7110720-SP	SCREW 11/64-40 L=7	マルヒラネジ 11/64-40 L=7	1
15		SS-3090610-SP	SCREW 9/64-40 L=6	マルネジ 9/64-40 L=6	2
16		118-03004	LOOPER COVER HINGE PIN	ルハカハ ヒンジク	1
17		SS-7090610-SP	SCREW 9/64-40 L=6	マルヒラネジ 9/64-40 L=6	1
18		122-00903	LOOPER COVER	ルハカハ	1
19		SS-8110410-TP	SCREW 11/64-40 L= 3.5	トメネジ 11/64-40 L=3.5	1
20		122-00804	LOOPER COVER BRACKET	ルハカハ ウケタイ	1
21		121-03206	LOOPER COVER PRESSER PLATE	ルハカハ オサエ イタ	1
22		121-01408	LOOPER COVER GUIDE PRATE	ルハカハ カイトハン	1
23		122-00655	SIDE COVER ASM.	ヨコカハ クミ	1
24		SS-4120615-SP	SCREW 3/16-28 L=6	ナハネジ 3/16-28 L=6	2
25		SS-6111010-SP	SCREW 11/64-40 L= 9.5	ヒラネジ 11/64-40 L=9.5	2
26		121-03404	LOOPER COVER PRESSER SPRING	ルハカハ オサエ ハネ	1

## 2. FRAME COMPONENTS(2)

フレーム関係 (2)

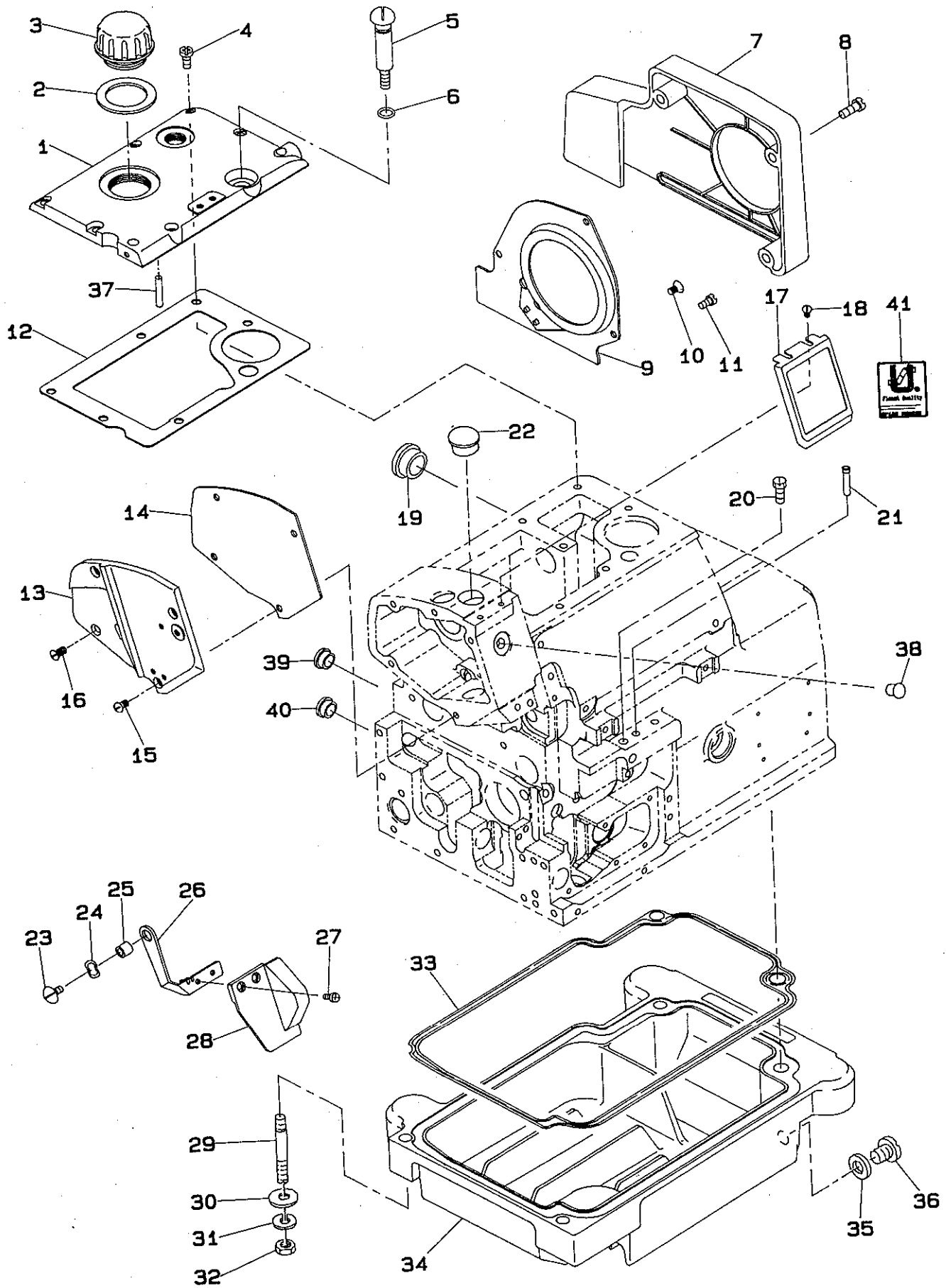



REF.NO	NOTE	PART NO.	DESCRIPTION	ヒンメイ	Qty
1		121-00400	UPPER COVER	ウエカハ	1
2		121-00707	GASKET	チュウゴアナ フタ ハッキン	1
3		121-00608	OIL CAP	チュウゴアナ フタ	1
4		SS-4121215-SP	SCREW 3/16-28 L=12	ナハネジ 3/16-28 L=12	6
5		121-00806	OIL DRAIN SCREW	フィルタージツ ハイユネジ	1
6		RO-0781901-00	RUBBER RING	Oリング	1
7		121-01903	BELT COVER	ベルトカハ	1
8		SS-4151215-SP	SCREW	ナハネジ 15/64-28 L=12	3
9		121-01804	COOLING FAN PLATE	レイキヤクファン イタ	1
10		SS-1110840-SP	SCREW 11/64-40 L=8	サラネジ 11/64-40 L=8	1
11		SS-7110840-SP	SCREW 11/64-40 L=7.8	マルヒラネジ 11/64-40 L=7.8	2
12		121-00509	UPPER COVER GASKET	ウエカハ ハッキン	1
13		121-00202	SIDE COVER	ソクメン カハ	1
14		121-00301	SIDE COVER GASKET	ソクメンカハ ハッキン	1
15		SS-4110715-SP	SCREW 11/64-40 L=7	ナハネジ 11/64-40 L=7	3
16		SS-2110920-TP	SCREW 11/64-40 L=8.5	マルサラネジ 11/64-40 L=8.5	1
17		121-02505	BRAND BASE	ブランドベース	1
18		SS-3090510-SP	SCREW 9/64-40 L=5	マルネジ 9/64-40 L=5	2
19		TA-2050805-RO	RUBBER PLUG	トメセン D=20.5 L=8	1
20		SS-9151210-TP	SCREW 15/64-28 L=11.8	ロツカクホルト 15/64-28	1
21		118-05207	THREAD GUIDE, LARGE	イトミチ タイ	2
22		TA-1701107-RO	RUBBER PLUG	トメセン	1
23		SS-5110710-SP	SCREW 11/64-40 L=7	トラスネジ 11/64-40 L=7	1
24		WZ-0850302-KO	WAVED WASHER 8.5X12.5X0.3	ナミカタサカネ 8.5X12.5X0.3	1
25		B3013-141-HOA	WASHER	リタロツト オサエカネ サカネ	1
26		121-02000	SAFETY PLATE BRACKET	メホコカハ タイ	1
27		SS-7090611-SL	SCREW 9/64-40 L=6.1	マルヒラネジ 9/64-40 L=6.1	2
28		121-04907	SAFETY PLATE	メホコカハ	1
29		115-03703	SCREW STUD	シチューホルト	4
30		WP-0751576-SD	WASHER 7.5X19X1.5	ヒラサカネ 7.5X19X1.5	4
31		WS-0822010-KP	SPRING WASHER 8.2X15X2	ハネサカネ 8.2X15X2	4
32		NS-6680410-SP	NUT 9/32-28	ロツカクナツト 9/32-28	4
33		122-01208	OIL RESERVOIR GASKET	アブラタマリ ハッキン	1
34		122-01109	OIL RESERVOIR	アブラタマリ	1
35		118-10306	OIL DRAIN CAP GASKET	ハイユネジ ハッキン	1
36		SS-6741010-SP	SCREW 3/8-28 L=10	ヒラネジ 3/8-28 L=10	1
37		PS-0300132-KH	SPRING PIN 3X13	スプリングピン	1
38		TA-0750704-RO	RUBBER PLUG	トメセン	1
39		TA-0800504-RO	PLUG D=8 L=4.5	トメセン D=8X4.5	1
40		TA-1470702-RO	RUBBER PLUG	トメセン	1
41		122-60204	BRAND LABEL	ブランドラベル	1

### 3. CRANKSHAFT COMPONENTS

主軸関係

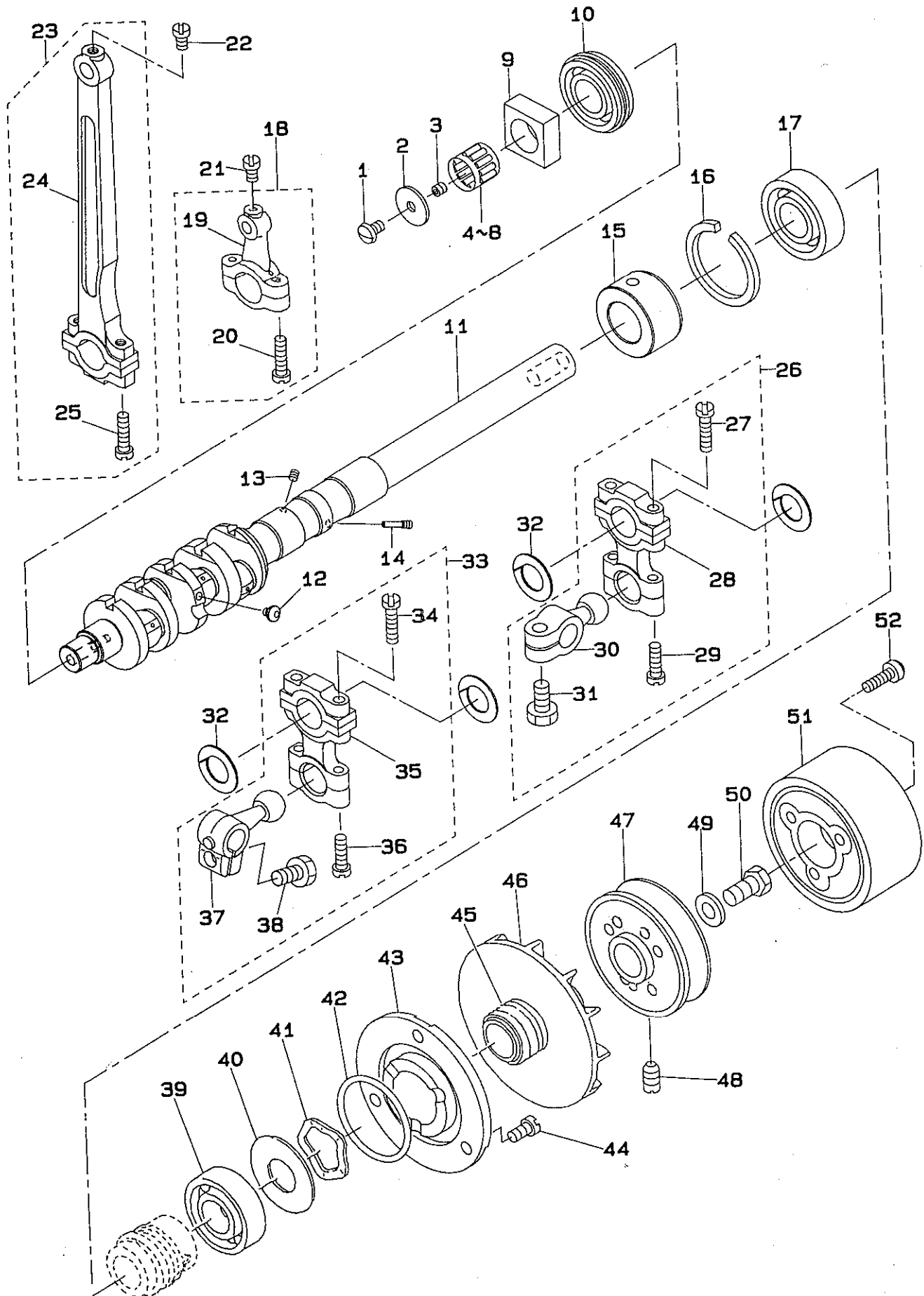

REF.NO	NOTE	PART NO.	DESCRIPTION	ヒンメイ	Qty
1		SS-5110740-TP	SCREW 11/64-40 L= 6.5	トラスネジ 11/64-40 L=6.5	1
2		122-04004	THRUST HOLDER	カクコマ スラストウケ	1
3		SS-8110422-TP	SCREW 11/64-40 L=4	トメネジ 11/64-40 L=4	1
4	#01	SB-3120003-0A	BEARING	コロカブリジクウケ	1
5	#01	SB-3120003-0B	BEARING	コロカブリジクウケ	1
6	#01	SB-3120003-0C	BEARING	コロカブリジクウケ	1
7	#01	SB-3120003-0D	BEARING	コロカブリジクウケ	1
8	#01	SB-3120003-0E	BEARING	コロカブリジクウケ	1
9		122-10100	SLIDE BLOCK	ジョウケオクリ カクコマ	1
10		122-04202	BALL BEARING D	ジュシク ホール ヲアリンク D	1
11		122-03600	CRANK SHAFT	ジュシク	1
12		SS-5080212-TP	SCREW 1/8-44 L=2	ハイントネジ	5
13		SS-8080410-TP	SCREW 1/8-44 L=3.5	トメネジ 1/8-44 L=3.5	1
14		122-04103	SCREW 1/8-44 L=3.2	トメネジ 1/8-44 L=3.2	1
15		122-03907	CRANK SHAFT BUSHING C	Cメタル	1
16		B1212-704-000	SCREW 11/64-40 L=18	マルヒラネジ 11/64-40 L=18	1
17		B1211-804-000	BALL BEARING B	ジュシク ホール ヲアリンク B	1
18		121-32155	KNIFE DRIVING ROD ASM.	ウエ メスロツ クミ	1
19		121-32106	KNIFE DRIVING ROD	ウエ メスロツ	(1)
20		SS-7111810-TP	SCREW 11/64-40 L=18	マルヒラネジ 11/64-40 L=18	(2)
21		SS-7110840-SP	SCREW 11/64-40 L=7.8	マルヒラネジ 11/64-40 L=7.8	1
22		SS-7110840-SP	SCREW 11/64-40 L=7.8	マルヒラネジ 11/64-40 L=7.8	1
23		121-09153	CONNECTING ROD ASM.	ハリクトウ ロツ クミ	1
24		121-09104	CONNECTING ROD	ハリクトウ ロツ	(1)
25		SS-7111810-TP	BEARING RETAINER	ホール ヲアリンク トメワ	(2)
26		121-22354	UPPER LOOPER ROD ASM.	ウエルハタマウチ クミ	1
27		SS-7111810-TP	SCREW 11/64-40 L=18	マルヒラネジ 11/64-40 L=18	(2)
28		121-22107	LOOPER DRIVING ROD	ルハロロツ	(1)
29		SS-7111410-TP	SCREW 11/64-40 L=14	マルヒラネジ 11/64-40 L=14	(2)
30		121-22305	UPPER LOOPER ARM	ウエルハキョウワン	(1)
31		SS-9151210-TP	SCREW 15/64-28 L=11.8	ロツカクホルト 15/64-28	(1)
32		121-22206	STOPPER	ルハロロツ フレツメ	4
33		122-15158	LOWER LOOPER ROD ASM., A	シタルハタマウチ A クミ	1
34		SS-7111810-TP	SCREW 11/64-40 L=18.	マルヒラネジ 11/64-40 L=18	(2)
35		121-22107	LOOPER DRIVING ROD	ルハロロツ	(1)
36		SS-7111410-TP	SCREW 11/64-40 L=14	マルヒラネジ 11/64-40 L=14	(2)
37		122-15109	LOWER LOOPER ARM A	シタルハキョウワン A	(1)
38		SS-9151210-TP	SCREW 15/64-28 L=11.8	ロツカクホルト 15/64-28	(1)
39		B1211-804-000	BALL BEARING A	ジュシク ホール ヲアリンク A	1
40		115-10609	WASHER	ハアリンク ウケイタ	1
41		WZ-2640310-KH	WAVED WASHER 26.4X33.9X3.5	ナミカタサカネ 26.4X33.9X3.5	1
42		RO-3473501-00	RUBBER RING	Oリング	1
43		121-07702	THRUST HOLDER	スラストウケ	1
44		SS-4120915-SP	SCREW 3/16-28 L=9	ナハネジ 3/16-28 L=9	3
45		121-07801	OIL SHIELD	ジュシク アブラキリ	1
46		118-11601	COOLING FAN	レイキヤクファン	1
47		121-07611	FLYWHEEL	ハスミクマルマ(A)	1
48		SS-8151150-SP	SCREW 15/64-28 L=10.5	トメネジ 15/64-28 L=10.5	2
49		WP-0764016-SP	WASHER	ヒラサカネ 76X20X4	1
50		SS-9681610-TP	SCREW 9/32-28 L=16	ロツカクホルト 9/32-28 L=16	1
51		122-03816	FLYWHEEL C	ハスミクマルマ(C)	1
52		SS-7111410-SP	SCREW 11/64-40 L=14	マルヒラネジ 11/64-40 L=14	3

Note (注記) #01...SELECTIVE PART

選択部品

# 4. NEEDLE DRIVING SHAFT COMPONENTS

## 針駆動軸関係

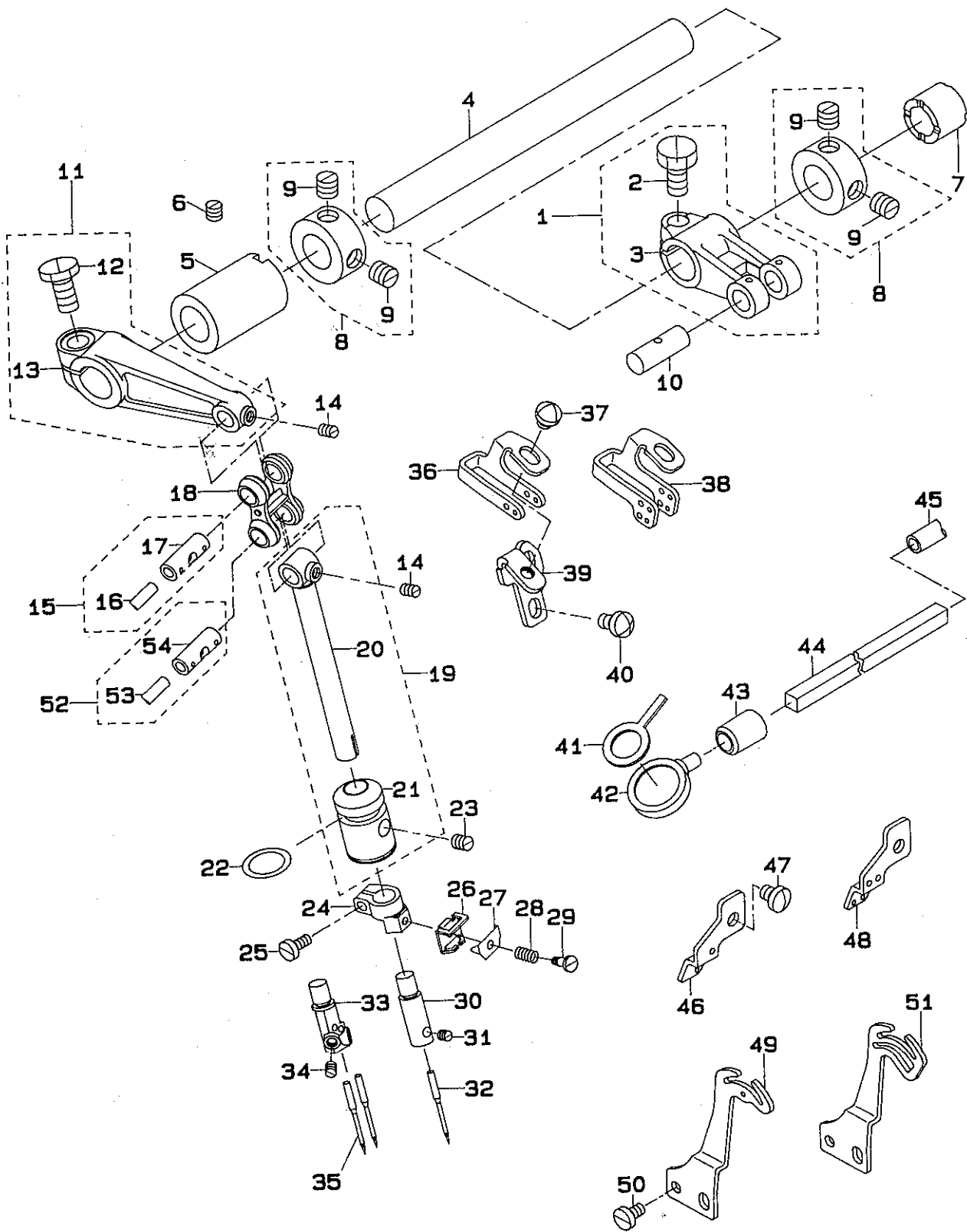

REF.NO	NOTE	PART NO.	DESCRIPTION	ヒンメイ	Qty
1		121-09252	FEED FORKED CRANK ASM.	ハリクトウ フタマタ クランク クミ	1
2		SS-9151210-TP	SCREW 15/64-28 L=11.8	ロツカクホルム 15/64-28	(1)
3		121-09203	NEEDLE DRIVING FORKED CRANK	ハリクトウ フタマタ クランク	(1)
4		121-09302	NEEDLE DRIVING SHAFT	ハリクトウジク	1
5		121-09401	BUSHING, FRONT	ハリクトウジウリ マイメタル	1
6		SS-8120410-SP	SCREW	トメネジ	1
7		121-09500	BUSHING, REAR	ハリクトウジク ウシロメタル	1
8		CS-1201010-SH	THRUST COLLAR ASM. D=12 W=10	スラストウケ D=12 W=10 クミ	2
9		SS-8660610-TP	SCREW 1/4-40 L=6	トメネジ 1/4-40 L=6	(4)
10	#01	118-23804	CRANK PIN C	オクリフタマタ クランクピオン C	1
11		121-09658	NEEDLE DRIVING ARM ASM.	ハリクトウウヂク クミ	1
12		SS-9151210-TP	SCREW 15/64-28 L=11.8	ロツカクホルム 15/64-28	(1)
13		121-09609	NEEDLE DRIVING LEVER	ハリクトウウヂク	(1)
14		SS-8090530-TP	SCREW 9/64-40 L= 5.0	トメネジ 9/64-40 L=5	2
15	#01	121-09955	LINK PIN ASM.	ハリクトウリンク ピオン クミ	1
16		CQ-2520000-00	OIL WICK	ユシ	(0.1)
17		121-09906	LINK PIN C	ハリクトウリンク ピオン C	(2)
18		121-10102	NEEDLE DRIVING LINK	ハリクトウリンク	1
19		121-10250	NEEDLE HOLDER ASM.	ハリホウ クミ	1
20		121-10201	NEEDLE HOLDER	ハリホウ	(1)
21		121-10300	NEEDLE HOLDER BUSHING	ハリホウ メタル	(1)
22		RO-1082401-00	RUBBER RING	オリンク	1
23		SS-8110710-SP	SCREW	トメネジ	1
24		121-10409	NEEDLE CLAMP HOLDER	ハリトメ タキ	1
25		SS-6080720-SP	SCREW	ヒラネジ 1/8-44 L=7	1
26	#05	121-10607	NEEDLE THREAD PRESSER GUIDE, A	ハリトオサエ イトアンナイ A	1
27		121-10904	NEEDLE THREAD PRESSER PLATE	ハリトオサエイタ A	1
28		121-10805	NEEDLE THREAD PRESSER SPRING	ハリトオサエ ハネ	1
29		SD-0280401-SL	HINGE SCREW D=2.8 H=4	タネネジ D=2.8 H=4	1
30	#02	121-48607	NEEDLE CLAMP	1 ホンハリハリトメ	1
31	#02	SS-8080310-TP	SCREW 1/8-44 L=2.8	トメネジ 1/8-44 L=2.8	1
32	#02	MDC-270B1100	NEEDLE DCX27 #11	ハリ DCX27 #11	1
33	#03	121-48706	NEEDLE CLAMP, 2-NEEDLE	ニホンハリハリトメ	1
34	#03	SS-8080310-TP	SCREW 1/8-44 L=2.8	トメネジ 1/8-44 L=2.8	2
35	#03	MDC-270B1100	NEEDLE DCX27 #11	ハリ DCX27 #11	2
36	#02	121-11209	NEEDLE THREAD GUIDE	ハリイトアンナイ	1
37		SS-4110515-SP	SCREW 11/64-40 L=5	ナネネジ 11/64-40 L=5	1
38	#03	121-11308	THREAD GUIDE, 2-NEEDLE	ニホンハリハリイトアンナイ	1
39		121-12108	NEEDLE THREAD GUIDE STAND	ハリイト アンナイイ	1
40		SS-4110715-SP	SCREW 11/64-40 L=7	ナネネジ 11/64-40 L=7	2
41		121-12306	FELT A	ハリ カンリュウフェルト A	1
42		121-12207	COVER	ハリ カンリュウカバー	1
43		TA-0951301-R0	OIL FELT	トメセン	1
44		121-12405	FELT B	ハリ カンリュウフェルト B	1
45		BT-0600402-EA	LUBRICATING PIPE	チューブ	0.2
46	#02	121-11803	TAKE-UP LEVER GUIDE	ハリイト テンビンカイト	1
47		SS-4110515-SP	SCREW 11/64-40 L=5	ナネネジ 11/64-40 L=5	1
48	#03	121-11902	TAKE-UP LEVER GUIDE, 2-NEEDLE	ニホンハリハリイトテンビンカイト	1
49	#02	121-11506	NEEDLE THREAD TAKE-UP LEVER	ハリイト テンビン	1
50		SS-6090670-TP	SCREW 9/64-40 L=6	ヒラネジ 9/64-40 L=6	2
51	#03	121-11805	TAKE-UP LEVER, 2-NEEDLE	ニホンハリハリイトテンビン	1
52	#01	121-09955	LINK PIN ASM.	ハリクトウリンクピオン クミ	1
53		CQ-2520000-00	OIL WICK	ユシ	(0.1)
54		121-09906	LINK PIN C	ハリクトウリンク ピオン C	(1)

Note (注記) #01...SELECTING PART FOR FIT TOLERANCE  
 #02...FOR SP161S800M040  
 #03...FOR SP172S900MADC

選択かん合部品  
 SP161S800M040 用  
 SP172S900MADC 用

5. FEED MECHANISM COMPONENTS(1)

送り関係(1)

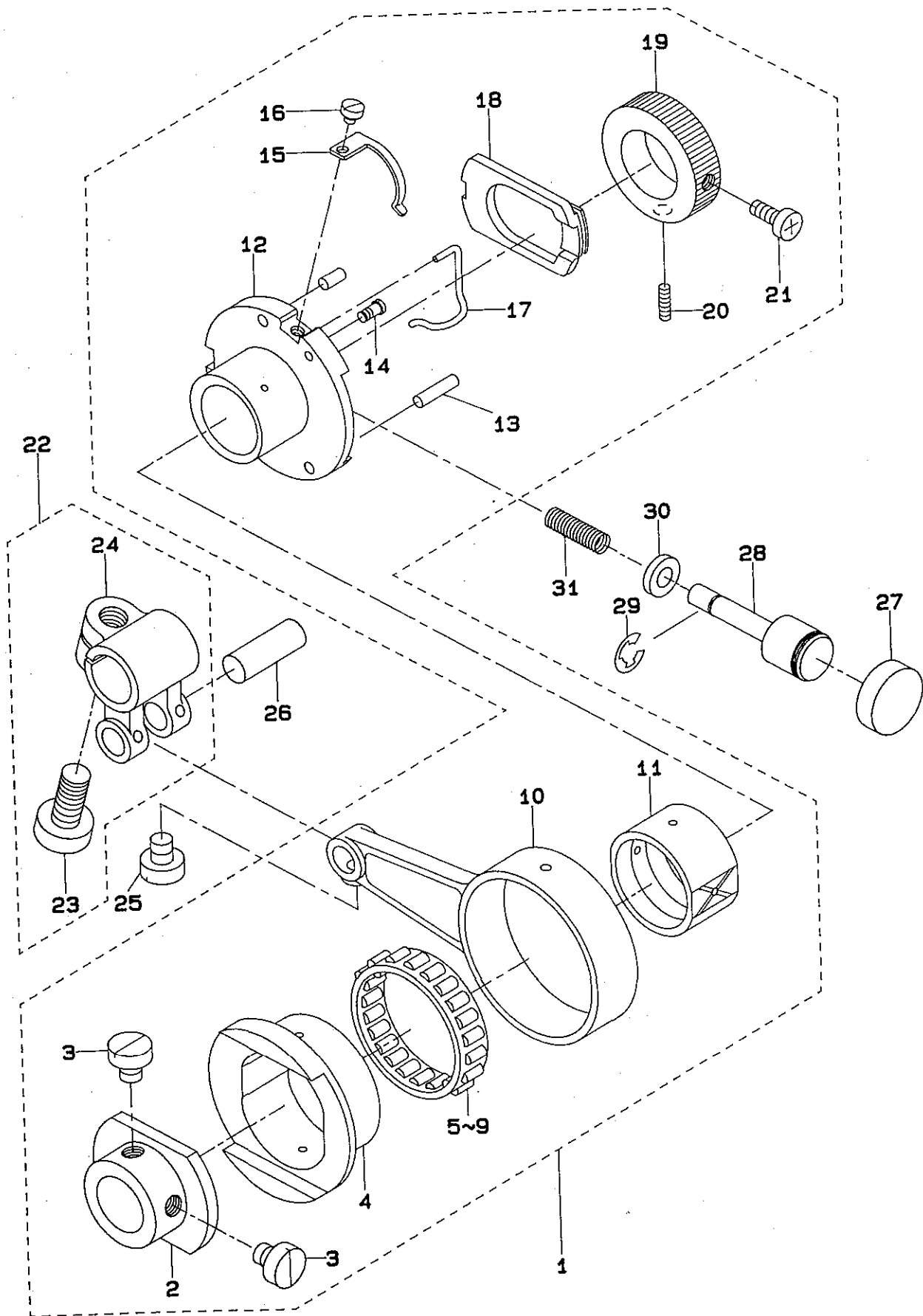

REF.NO	NOTE	PART NO.	DESCRIPTION	ヒ ン メ イ	Qty
1		122-08161	FEED ECCENTRIC BODY ASM.	オクリカム シジ <sup>ツ</sup> タ <sup>イ</sup> クミ	1
2		122-08104	FEED ECCENTRIC BODY	オクリカム シジ <sup>ツ</sup> タ <sup>イ</sup>	(1)
3		SS-6660710-TP	SCREW 1/4-40 L=7	ヒラネジ <sup>ツ</sup> 1/4-40 L=7	(2)
4		122-08203	FEED CAM	オクリカム	(1)
5	#01	SB-3350002-0A	BEARING	コロカ <sup>リ</sup> リジ <sup>ク</sup> ウケ	(1)
6	#01	SB-3350002-0B	BEARING	コロカ <sup>リ</sup> リジ <sup>ク</sup> ウケ	(1)
7	#01	SB-3350002-0C	BEARING	コロカ <sup>リ</sup> リジ <sup>ク</sup> ウケ	(1)
8	#01	SB-3350002-0D	BEARING	コロカ <sup>リ</sup> リジ <sup>ク</sup> ウケ	(1)
9	#01	SB-3350002-0E	BEARING	コロカ <sup>リ</sup> リジ <sup>ク</sup> ウケ	(1)
10		122-08906	CRANK ROD	オクリクランク ロット <sup>ツ</sup>	(1)
11		122-08302	SLIDE BLOCK	オクリカム カクコ <sup>マ</sup>	(1)
12		122-08401	FEED ADJUSTING CAM	オクリチョウセツ カム	(1)
13		PS-0300132-KH	SPRING PIN 3X13	スプリング <sup>ク</sup> ピ <sup>ン</sup>	(2)
14		SD-0260271-SP	HINGE SCREW D= 2.60 H= 2.7	タ <sup>ン</sup> ネジ <sup>ツ</sup> D=2.6 H=2.7	(1)
15		122-08807	RATCHET GEAR SPRING	ラチェット キ <sup>キ</sup> ヤ <sup>ハ</sup> ネ	(1)
16		SS-6080340-SP	SCREW 1/8-44 L=3.0	ヒラネジ <sup>ツ</sup> 1/8-44 L=2.9	(1)
17		122-08609	RATCHET PAWL SPRING	ラチェット オサエ <sup>ハ</sup> ネ	(1)
18		122-08500	RATCHET PAWL	ラチェット	(1)
19		122-08708	RATCHET GEAR	ラチェットキ <sup>キ</sup> ヤ	(1)
20		SS-6111110-SP	SCREW 11/64-40 L=11.0	ヒラネジ <sup>ツ</sup> 11/64-40 L=11	(1)
21		SS-8110520-TP	SCREW 11/64-40 L= 4.5	トメネジ <sup>ツ</sup> 11/64-40 L=4.5	(1)
22		122-09052	FORKEND CRANK ASM.	オクリフタマタクランク クミ	1
23		SS-9151210-TP	SCREW 15/64-28 L=11.8	ロツカクホ <sup>ル</sup> ト 15/64-28	(1)
24		122-09003	FORKEND CRANK	オクリ フタマタクランク	(1)
25		SS-7110910-TP	SCREW 11/64-40 L= 8.5	マルヒラネジ <sup>ツ</sup> 11/64-40 L=8.5	1
26	#01	118-23804	CRANK PIN C	オクリフタマタ クランクピ <sup>ン</sup> C	1
27		122-11801	PUSH BOTTON CAP	オンホ <sup>タン</sup> キャップ <sup>〇</sup>	1
28		122-11702	PUSH BOTTON STUD	オンホ <sup>タン</sup> ジ <sup>ク</sup>	1
29		RE-0320000-K0	SNAP RING 3.2	Eカ <sup>タ</sup> メワ 3.2	1
30		121-18600	OIL SHEET	オンホ <sup>タン</sup> ジ <sup>ク</sup> オイルシート	1
31		B1652-704-000	SPRING	オンホ <sup>タン</sup> ハ <sup>ネ</sup>	1

Note ( 注記 )#01...SELECTIVE PART

選択部品

# 6. FEED MECHANISM COMPONENTS(2)

送り関係(2)

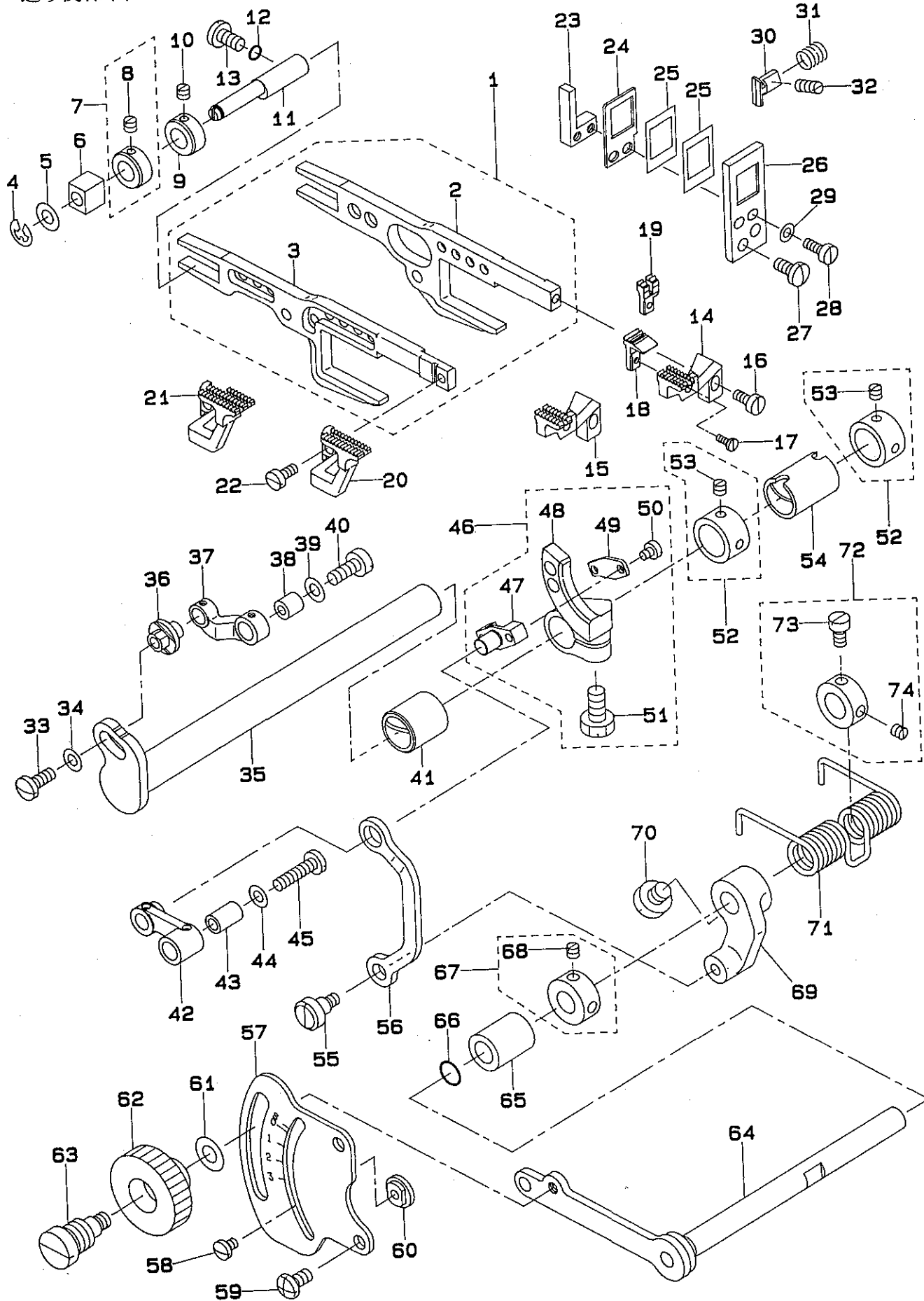



REF.NO	NOTE	PART NO.	DESCRIPTION	ヒンメイ	Qty
1		122-09953	MAIN FEED BAR ASM.	シュオクリヨウトウカン	1
2		122-09904	MAIN FEED BAR	シュ オクリ ヨウトウカン	(1)
3		122-10001	DIFFERENTIAL FEED BAR	フク オクリ ヨウトウカン	(1)
4		RE-0400000-KO	E-SHAPED SNAP RING (4MM)	Eカトメワ 4	1
5		115-29906	WASHER	ヨートーカンササエジク サカネ	1
6		122-10308	SLIDE BLOCK	ヨウトウカンササエ カクコマ	1
7		118-28050	COLLAR ASM.	ササエジク カラー クミ	1
8		SS-8110410-TP	SCREW 11/64-40 L= 3.5	トメネジ 11/64-40 L=3.5	(1)
9		CS-0790731-SH	THRUST COLLAR	スラストウケ	(1)
10		SS-8110410-TP	SCREW 11/64-40 L= 3.5	トメネジ 11/64-40 L=3.5	1
11		122-10209	FEED BAR SHAFT	ヨウトウカン ササエジク	1
12		RO-0371801-00	RUBBER RING	Oリング	1
13		SS-7120910-SP	SCREW 3/16-28 L=9	マルヒラネジ 3/16-28 L=9	1
14	#01	122-35107	MAIN FEED DOG	シュ オクリハ	1
15	#02	122-35206	MAIN FEED DOG	シュ オクリハ	1
16		SS-6090810-TP	SCREW 9/64-40 L=7.5	ヒラネジ 9/64-40 L=7.5	1
17		SS-7060610-SP	SCREW 3/32-56 L= 5.5	マルヒラネジ 3/32-56 L=5.5	1
18		122-38101	AUXILIARY FEED DOG	ホジヨ オクリハ	1
19	#03	122-38200	AUXILIARY FEED DOG	ホジヨオクリハ	1
20	#01	122-36600	DIFFERENTIAL FEED DOG	フク オクリハ	1
21	#02	122-36709	DIFFERENTIAL FEED DOG	フク オクリハ	1
22		SS-6090810-TP	SCREW 9/64-40 L=7.5	ヒラネジ 9/64-40 L=7.5	1
23		122-10605	FEED BAR SUPPORT, LEFT	ヨウトウカン オサエ ヒタリ	1
24		122-10506	RUBBER SUPPORT	ホウジンゴムオサエ	1
25		121-18303	RUBBER	ホウジンゴム	2
26		122-10407	RUBBER CASE	ホウジンゴムケース	1
27		SS-7110910-SP	SCREW 11/64-40 L=8.5	マルヒラネジ 11/64-40 L=8.5	2
28		SS-6090910-TP	SCREW 9/64-40 L=9	ヒラネジ 9/64-40 L=9	2
29		WP-0371026-SD	WASHER 3.7X7X1	ヒラサカネ 3.7X7X1	2
30		122-10704	FEED BAR SUPPORT, RIGHT	ヨウトウカン オサエ ミキ	1
31		122-10803	SPRING	ヨウトウカン オサエハネ	1
32		SS-8111010-TP	SCREW 11/64-40 L=9.5	トメネジ 11/64-40 L=9.5	1
33		SS-6111010-TP	SCREW	マルヒラネジ	1
34		B3228-771-00B	BOBBIN WINDER SPACER	イトマキ スパ-サ-	1
35		122-09102	ROCKER SHAFT	オクリジク	1
36		122-09201	MAIN FEED PIN	シュ オクリピン	1
37		122-09300	MAIN FEED LINK	シュ オクリ リンク	1
38		B1620-804-000	COLLAR	シュオクリ ヒンカラー	1
39		B1707-155-000	FEED DRIVING SLIDE BLOCK WASHE	オクリ カクコマジク サカネ	1
40		SS-6121220-TP	SCREW 3/16-28 L=11.5	ヒラネジ 3/16-28 L=11.5	1
41		122-10902	BUSHING, FRONT	オクリジク マイタル	1
42		122-09805	LINK	フクオクリ リンク	1
43		122-09706	COLLAR	フクオクリ リンクカラー	1
44		WP-0451026-SH	WASHER	ヒラサカネ	1
45		SS-7111810-TP	SCREW 11/64-40 L=18	マルヒラネジ 11/64-40 L=18	1
46		122-09458	SUB-FEED ARM ASM.	フクオクリウケ (クミ)	1
47		122-09508	PIN	フクオクリ ピン	(1)
48		122-09409	FEED ROCKER	フク オクリ ウケ	(1)
49		122-09607	PIN COVER	フクオクリ ピン フタ	(1)
50		SS-6080410-SP	SCREW 1/8-44 L=4	ヒラネジ 1/8-44 L=4	(2)
51		SS-9151210-TP	SCREW 15/64-28 L=11.8	ロツカホルト 15/64-28	(1)
52		CS-127101A-SH	THRUST COLLAR ASM. D=12.7 W=10	スラストウケ D=12.7 W=10 クミ	2
53		SS-8660610-TP	SCREW 1/4-40 L=6	トメネジ 1/4-40 L=6	(4)
54		122-11009	BUSHING, REAR	オクリジク ウシロメタル	1
55		SD-0640321-TP	HINGE SCREW	タネネジ	1
56		122-11405	LINK	サトウ チョウセツ リンク	1
57		122-11603	DIFFERENTIAL FEED GRADUATION	サトウチョウセツ メモリイタ	1
58		SS-7090540-TP	SCREW 9/64-40 L=5	マルヒラネジ 9/64-40 L=5	2
59		SS-4120915-SP	SCREW 3/16-28 L=9	ナネネジ 3/16-28 L=9	2
60		115-29005	STOPPER	サトウチョウセツ ストッパ-	2
61		WP-0621016-SD	WASHER 6.2X13X1	ヒラサカネ 6.2X13X1	1
62		B1647-704-000-A	DIFFERENTIAL FEED LOCK NUT	サトウ ロツクナツト	1
63		B1646-704-000-A	DIFFERENTIAL FEED HINGE SCREW	サトウ タネネジ	1
64		122-11157	ROCKER SHAFT ASM.	サトウチョウセツジク ナツゴウ	1
65		121-18709	ROCKER SHAFT METAL	サトウ チョウセツジク メタル	1
66		RO-0601501-00	RUBBER RING	Oリング	1
67		CS-087081B-SH	THRUST COLLAR ASM.	スラストカラークミ	1
68		SS-8110410-TP	SCREW 11/64-40 L= 3.5	トメネジ 11/64-40 L=3.5	2
69		122-11306	DIFFERENTIAL FEED ROCKER	サトウチョウセツウケ	1
70		SS-6660610-TP	SCREW 1/4-40 L=6	ヒラネジ 1/4-40 L=6	1
71		122-11504	SPRING	サトウ チョウセツレハ- ハネ	1
72		CS-087081C-SH	THRUST COLLAR ASM.	スラストカラークミ	1
73		B1536-804-000	PIN	オサエジク スラストウケピン	1
74		SS-8110410-TP	SCREW 11/64-40 L= 3.5	トメネジ 11/64-40 L=3.5	1

Note ( 注記 ) #01...FOR SP161S800M040 SP161S800M040 用  
#02...FOR SP172S900MADC SP172S900MADC 用  
#03...FOR P05/Q01 EXCHANGING PARTS P05/Q01 交換部品

# 7. UPPER & LOWER LOOPER COMPONENTS

上ルーパー、下ルーパー関係

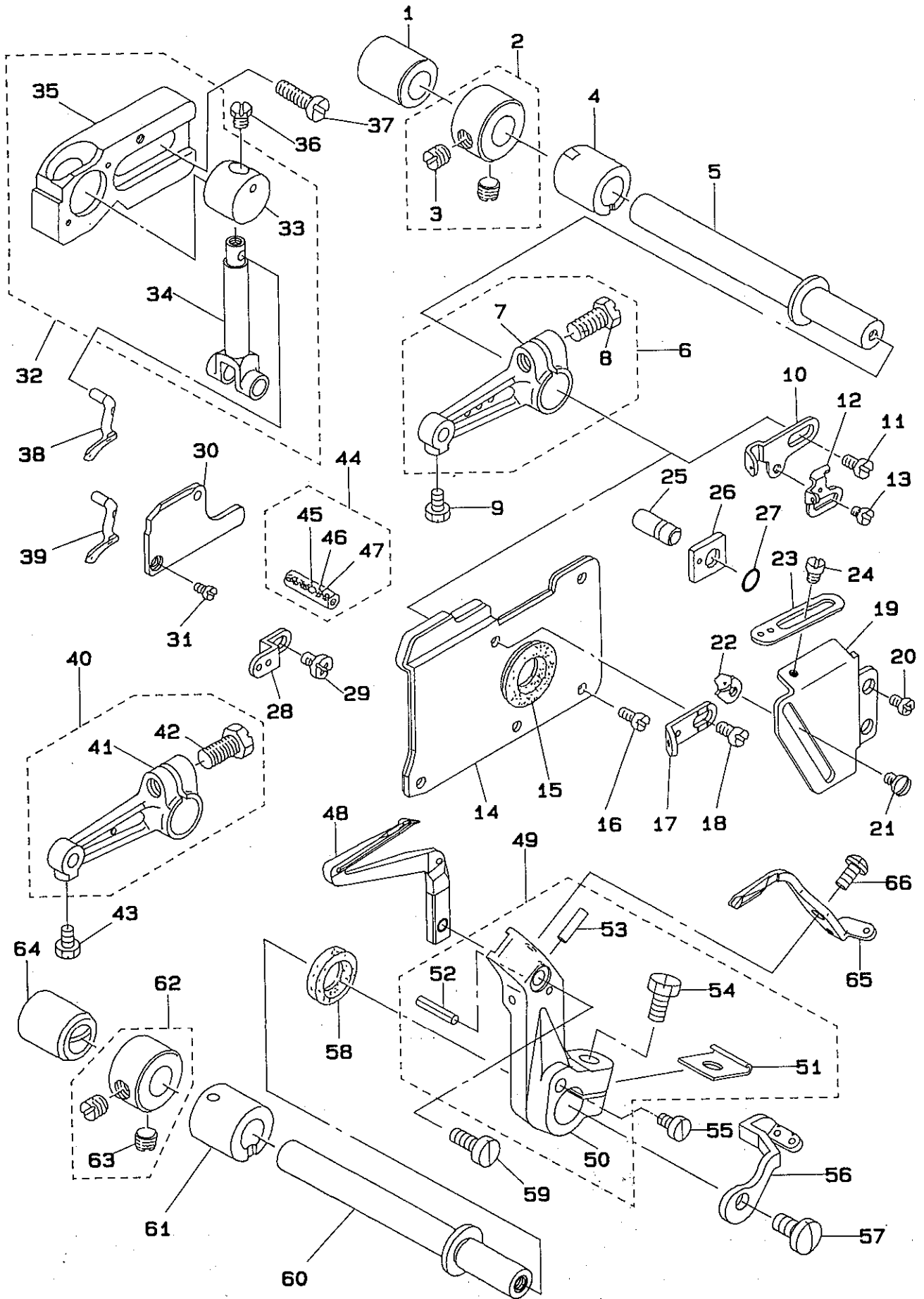

REF.NO	NOTE	PART NO.	DESCRIPTION	ヒンメイ	Qty
1		121-22602	BUSHING, REAR	ル-ハ°-ジク ウシロメタル	1
2		CS-103121A-SH	COLLAR ASM. D=10.32 W=12	スラストウケ D=10.32 W=12 クミ	1
3		SS-8660530-TP	SCREW 1/4-40 L= 4.5	トメネジ 1/4-40 L=4.5	(2)
4		121-22503	BUSHING, FRONT	ル-ハ°-ジク マイメタル	1
5		121-22404	UPPER LOOPER SHAFT	ウエ ル-ハ°-ジク	1
6	#02	122-14656	UPPER LOOPER ARM D ASM.	ウエル-ハ°-ウテ D (クミ)	1
7		122-14607	UPPER LOOPER ARM D	ウエル-ハ°-ウテ D	(1)
8		SS-9151210-TP	SCREW 15/64-28 L=11.8	ロツカクホルト 15/64-28	(1)
9		SS-9090610-TP	SCREW 9/64-40 L=5.5	ロツカクホルト 9/64-40 L=5.5	1
10		121-24004	THREAD TAKE-UP, RIGHT	ウエル-ハ°-デンヒン ミキ	1
11		SS-7110840-SP	SCREW 11/64-40 L=7.8	マルヒラネジ 11/64-40 L=7.8	1
12		118-33506	LOWER LOOPER THREAD TAKE-UP	シタル-ハ° デンヒン	1
13		SS-6080410-SP	SCREW 1/8-44 L=4	ヒラネジ 1/8-44 L=4	1
14		122-15554	OIL SHIELD PLATE ASM.	ル-ハ°-カイト ユホウハン クミ	1
15		B2530-704-000	UPPER LOOPER SHAFT RUBBER RING	ウツル-ハ°ジク ユムワ	1
16		SS-6090630-SP	SCREW 9/64-40 L=6	ヒラネジ 9/64-40 L=6	1
17		121-24202	UPPER LOOPER THREAD GUIDE	ウエル-ハ°-イトアンナイ チュウ	1
18		SS-7090850-SP	SCREW 9/64-40 L=8	マルヒラネジ 9/64-40 L=8	1
19		121-23808	LOOPER THREAD TAKE-UP COVER	ル-ハ°-デンヒンカバー	1
20		SS-4110715-SP	SCREW 11/64-40 L=7	ナハネジ 11/64-40 L=7	2
21		SS-3090610-SP	SCREW 9/64-40 L=6	マルネジ 9/64-40 L=6	1
22		118-33407	LOWER LOOPER THREAD GUIDE	シタル-ハ° イトアンナイ	1
23		121-23907	THREAD GUIDE, RIGHT	ウエ ル-ハ°-イトアンナイ ミキ	1
24		SS-3090610-SP	SCREW 9/64-40 L=6	マルネジ 9/64-40 L=6	1
25		118-31906	PIN	ゲ-ジ コデヒン	1
26		118-31807	GAUGE	ウツル-ハ°カイト ササエゲ-ジ	1
27		RO-0371801-00	RUBBER RING	オリンク	1
28		122-15703	LOOPER THREAD GUIDE, UPPER	ウエ ル-ハ°- イトアンナイ(ウエ)	1
29		SS-4090615-SP	SCREW 9/64-40 L=6	ナハネジ 9/64-40 L=6	1
30		122-14805	UPPER LOOPER GUIDE COVER	ウエ ル-ハ°-カイト フタ	1
31		SS-7060610-SP	SCREW 3/32-56 L= 5.5	マルヒラネジ 3/32-56 L=5.5	2
32		122-14755	UPPER LOOPER GUIDE ASM.	ウエル-ハ°-カイト ササエクミ	1
33		121-23204	UPPER LOOPER GUIDE	ウエル-ハ°-カイト	1
34		121-22909	UPPER LOOPER HOLDER	ウエ ル-ハ°-タキ	1
35		122-14706	UPPER LOOPER GUIDE SUPPORT	ウエ ル-ハ°-カイト ササエ	1
36		SS-9090410-TP	SCREW	ロツカクホルト	1
37		SS-7151340-TP	SCREW 15/64-28 L=12.5	マルヒラネジ	2
38	#04	122-47300	UPPER LOOPER	ウエ ル-ハ°-	1
39	#05	122-47102	UPPER LOOPER	ウエル-ハ°-	1
40	#01	121-22859	UPPER LOOPER ARM B ASM.	ウエ ル-ハ°- ウテ B クミ	1
41		121-22800	UPPER LOOPER ARM B	ウエ ル-ハ°- ウテ B	(1)
42		SS-9151210-TP	SCREW 15/64-28 L=11.8	ロツカクホルト 15/64-28	(1)
43		SS-9090610-TP	SCREW 9/64-40 L=5.5	ロツカクホルト 9/64-40 L=5.5	1
44	#03	118-31757	PIN ASM.	ウツル-ハ°タキ ヒン クミ	1
45		118-31708	OIL WICK STOPPER BALL	ユシントメタマ	(1)
46		CQ-2020000-00	OIL WICK	ユシン	(0.1)
47		CQ-2000000-00	OIL WICK	ユシン	(0.1)
48		122-40107	LOWER LOOPER	シタル-ハ°-	1
49		122-15356	LOWER LOOPER ARM ASM.	シタル-ハ°-ジクウテ クミ	1
50		122-15307	LOWER LOOPER ARM	シタル-ハ°-ジクウテ	(1)
51		B2531-704-000	WASHER	ジクウテ シメワッシャー	(1)
52		PS-0200062-KH	SPRING PIN 2X6	スプリングピン 2X6	(1)
53		135-08700	HOOK COVER PRESSER SPRING PIN	カマカバー オサエハネヒン	(1)
54		SS-9151210-TP	SCREW 15/64-28 L=11.8	ロツカクホルト 15/64-28	(1)
55		SS-6090630-TP	SCREW 9/64-40 L=6	ヒラネジ 9/64-40 L=6	1
56		122-15604	LOOPER THREAD TAKE-UP, LEFT	ル-ハ°-デンヒン (ヒタリ)	1
57		SS-6111140-SP	SCREW 11/64-40 L=11	ヒラネジ 11/64-40 L=11	1
58		122-15406	OIL SEAL	シタル-ハ°-ジク オイルシール	1
59		SS-6090910-TP	SCREW 9/64-40 L=9	ヒラネジ 9/64-40 L=9	1
60		122-15208	LOWER LOOPER SHAFT	シタル-ハ°-ジク	1
61		122-14904	LOWER LOOPER BUSHING, FRONT	シタル-ハ°-ジク マイメタル	1
62		CS-100101D-SH	THRUST COLLAR ASM.	スラストカラー クミ	1
63		SS-8660530-TP	SCREW 1/4-40 L= 4.5	トメネジ 1/4-40 L=4.5	(2)
64		122-15000	LOWER LOOPER BUSHING, REAR	シタル-ハ°-ジク ウシロメタル	1
65		122-40602	NEEDLE GUARD	イトウバリウケ	1
66		SS-4080610-SP	SCREW 1/8-44 L=6.4	ナハネジ 1/8-44 L=6.4	1

Note (注記) #01...FOR SP161S800M040 SP161S800M040 用  
#02...FOR SP172S900MADC SP172S900MADC 用  
#03...SELECTING PART FOR FIT TOLERANCE 選択かん合部品  
#04...FOR SP151,SP161 & SP172 SP151,SP161,SP172 用  
(Needle #9,#11,#14) (針番手 #9,#11,#14)  
#05...FOR SP151,SP161 & SP172 SP151,SP161,SP172 用  
(Needle #14,#16,#18) (針番手 #14,#16,#18)

# 8. PRESSER FOOT COMPONENTS(1)

押え関係 (1)

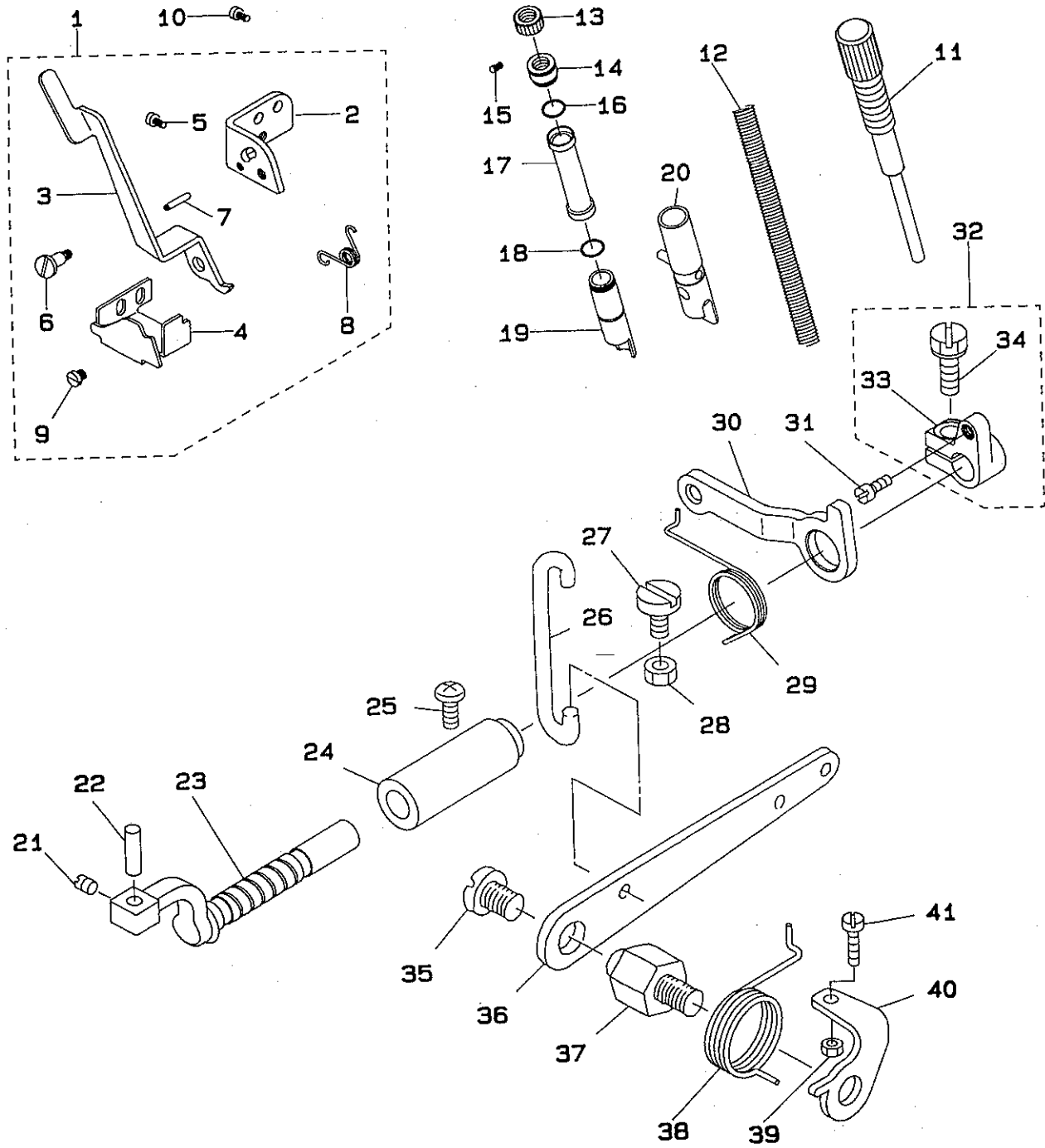

REF.NO	NOTE	PART NO.	DESCRIPTION	ヒ シ ヂ イ	Qty
1		121-15051	FOOT LIFTING LEVER STAND ASM.	オサエヒキアケレハ-タ-イクミ	1
2		121-15002	FOOT LIFTING LEVER STAND	ヒキアケレハ-タ-イ	(1)
3		121-15101	PRESSER FOOT LIFTING LEVER	オサエヒキアケレハ-	(1)
4		121-15200	STOPPER	オサエウデ-ストッパ-	(1)
5		SS-7110510-SP	SCREW 11/64-40 L=5	マルヒラネジ 11/64-40 L=5	(2)
6		SD-0640241-SP	HINGE SCREW D= 6.35 H= 2.4	タ-ンネジ D=6.35 H=2.4	(1)
7		PS-0300142-KH	SPRING PIN 0.3 X 14	スプリングピン 3X14	(1)
8		121-15309	SPRING	オサエ ヒキアケレハ-ネ	(1)
9		SS-6080340-SP	SCREW 1/8-44 L=3.0	ヒラネジ 1/8-44 L=2.9	(1)
10		SS-4110715-SP	SCREW 11/64-40 L=7	ナ-ネジ 11/64-40 L=7	2
11		121-14708	PRESSER REGULATOR SCREW	オサエ チョウセツネジ	1
12		B1515-804-00B	PRESSER SPRING	オサエ ハ-ネ B	1
13		121-14807	PRESSER REGULATOR NUT	オサエ チョウセツナット	1
14		121-14609	PRESSER REGULATOR SCREW WASHER	オサエチョウセツネジ-サ	1
15		SS-8110410-TP	SCREW 11/64-40 L= 3.5	トメネジ 11/64-40 L=3.5	1
16		RO-1100901-00	RUBBER RING	オリンク	1
17		121-14906	PRESSER BAR COVER	オサエホ-ウ カハ-	1
18		RO-1100901-00	RUBBER RING	オリンク	2
19		121-14302	PRESSER BAR BUSHING	オサエホ-ウ メタル	1
20		121-14450	PRESSER BAR ASM.	オサエホ-ウ クミ	1
21		SS-8110520-TP	SCREW 11/64-40 L= 4.5	トメネジ 11/64-40 L=4.5	1
22		121-14203	PRESSER FOOT ARM HINGE SHAFT	オサエウデ-ヒンシ-シク	1
23		121-13601	PRESSER FOOT SHAFT	オサエシク	1
24		121-13700	BUSHING	オサエシク メタル	1
25		SS-4121215-SP	SCREW 3/16-28 L=12	ナ-ネジ 3/16-28 L=12	1
26		118-19414	LIFTING HOOK	オサエアケレフツク	1
27		SS-6151210-SP	SCREW 15/64-28 L=12	ヒラネジ 15/64-28 L=12	1
28		NS-6150310-SP	NUT 15/64-28	ロツカクナット 15/64-28	1
29		118-19703	PRESSER FOOT ARM SPRING	オサエウデ-ハ-ネ	1
30		121-13908	LIFTING ARM	オサエアケレウデ	1
31		SS-8110710-TP	SCREW 11/64-40 L= 6.5	ヒラネジ 11/64-40 L=6.5	1
32		121-13858	THRUST ARM ASM.	オサエシク スラストウデ- クミ	1
33		121-13809	PRESSER FOOT SHAFT THRUST	オサエシク スラストウデ	(1)
34		SS-9151210-TP	SCREW 15/64-28 L=11.8	ロツカクホルト 15/64-28	(1)
35		SS-7161040-SP	SCREW 1/4-24 L= 9.5	マルヒラネジ 1/4-24 L=9.5	1
36		118-19307	LIFTING LEVER	オサエアケレハ-	1
37		118-19109	LIFTING LEVER SCREW	オサエアケレハ-ネジ	1
38		122-06702	LIFTING LEVER SPRING	オサエアケレハ-ハ-ネ	1
39		NS-6110420-SP	NUT 11/64-40	ロツカクナット 11/64-40	1
40		SS-7111410-SP	SCREW 11/64-40 L=14	マルヒラネジ 11/64-40 L=14	1
41		122-06603	LEVER STOPPER	オサエアケレハ-ストッパ-	1

9. PRESSER FOOT COMPONENTS(2)

押え関係 (2)

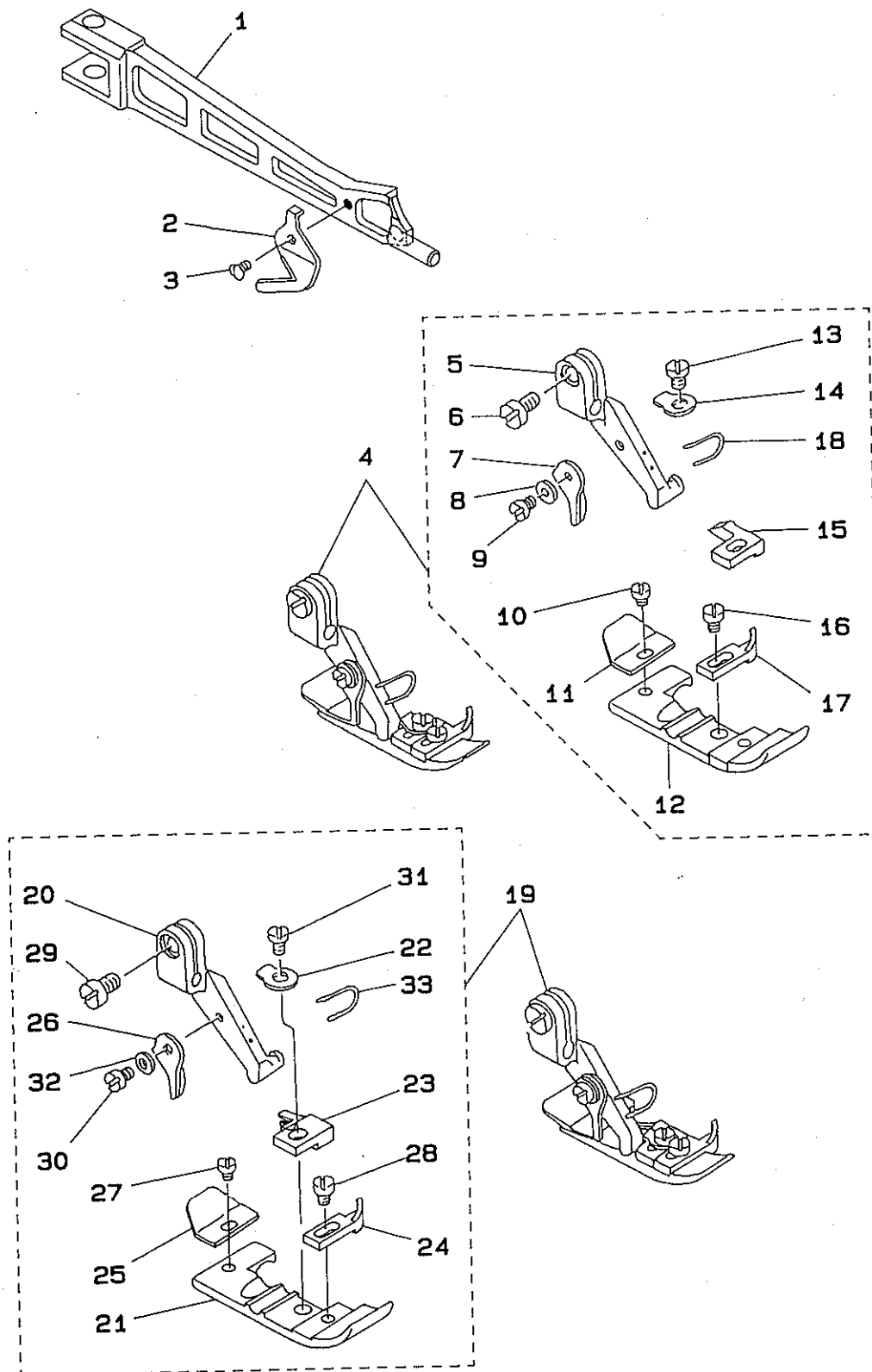

REF.NO	NOTE	PART NO.	DESCRIPTION	ヒ ン メ イ	Qty
1		121-14005	PRESSER FOOT ARM	オサエ ウヂ	1
2		B1528-804-000-A	THREAD TRIMMER	イトキリハ	1
3		SS-6060440-TP	SCREW 3/32-56 L=3.5	ヒラネジ	1
4	#01	122-30165	PRESSER FOOT ASM.	オサエケツコウ	1
5		118-72009	PRESSER FOOT HINGE	オサエヒンジ	(1)
6		SS-6090650-SP	SCREW 9/64-40 L=6	ヒラネジ 9/64-40 L=6	(1)
7		B1530-804-000	STOPPER	オサエ ストツハ	(1)
8		WP-0250516-SD	WASHER 2.5X6X0.5	ヒラサカネ 2.5X6X0.5	(1)
9		SS-7060610-SP	SCREW 3/32-56 L= 5.5	マルヒラネジ 3/32-56 L=5.5	(1)
10		SS-6060210-SP	SCREW 3/32-56 L= 1.9	ヒラネジ 3/32-56 L=1.9	(1)
11		B1511-814-000	REAR PRESSER FOOT	カラカントメ	(1)
12		122-32104	PRESSER FOOT	オサエ	(1)
13		SS-7080520-SP	SCREW 1/8-44 L=4.9	マルヒラネジ 1/8-44 L=4.9	(1)
14		B1508-804-00B	SPRING	オサエ トリツケハネ	(1)
15		B1509-804-C00	STITCH TONGUE	イトスヘリタ	(1)
16		SS-6060440-TP	SCREW 3/32-56 L=3.5	ヒラネジ	(1)
17		B1510-814-000	CURL GUARD	カールメ	(1)
18		118-20701	FINGER GUARD	ユビカト	1
19	#02	122-30264	PRESSER FOOT ASM.	オサエケツコウ	1
20		118-72009	PRESSER FOOT HINGE	オサエヒンジ	(1)
21		122-32104	PRESSER FOOT	オサエ	(1)
22		B1508-804-00B	SPRING	オサエ トリツケハネ	(1)
23		B1509-814-00P	STITCH TONGUE	イトスヘリタ	(1)
24		B1510-814-000	CURL GUARD	カールメ	(1)
25		B1511-814-000	REAR PRESSER FOOT	カラカントメ	(1)
26		B1530-804-000	STOPPER	オサエ ストツハ	(1)
27		SS-6060210-SP	SCREW 3/32-56 L= 1.9	ヒラネジ 3/32-56 L=1.9	(1)
28		SS-6060440-TP	SCREW 3/32-56 L=3.5	ヒラネジ	(1)
29		SS-6090650-SP	SCREW 9/64-40 L=6	ヒラネジ 9/64-40 L=6	(1)
30		SS-7060610-SP	SCREW 3/32-56 L= 5.5	マルヒラネジ 3/32-56 L=5.5	(1)
31		SS-7080520-SP	SCREW 1/8-44 L=4.9	マルヒラネジ 1/8-44 L=4.9	(1)
32		WP-0250516-SD	WASHER 2.5X6X0.5	ヒラサカネ 2.5X6X0.5	(1)
33		118-20701	FINGER GUARD	ユビカト	(1)

Note (注記) #01...FOR SP161S800M040  
#02...FOR SP172S900MADC

SP161S800M040 用  
SP172S900MADC 用

# 10. THREAD TENSION COMPONENTS

糸調子関係

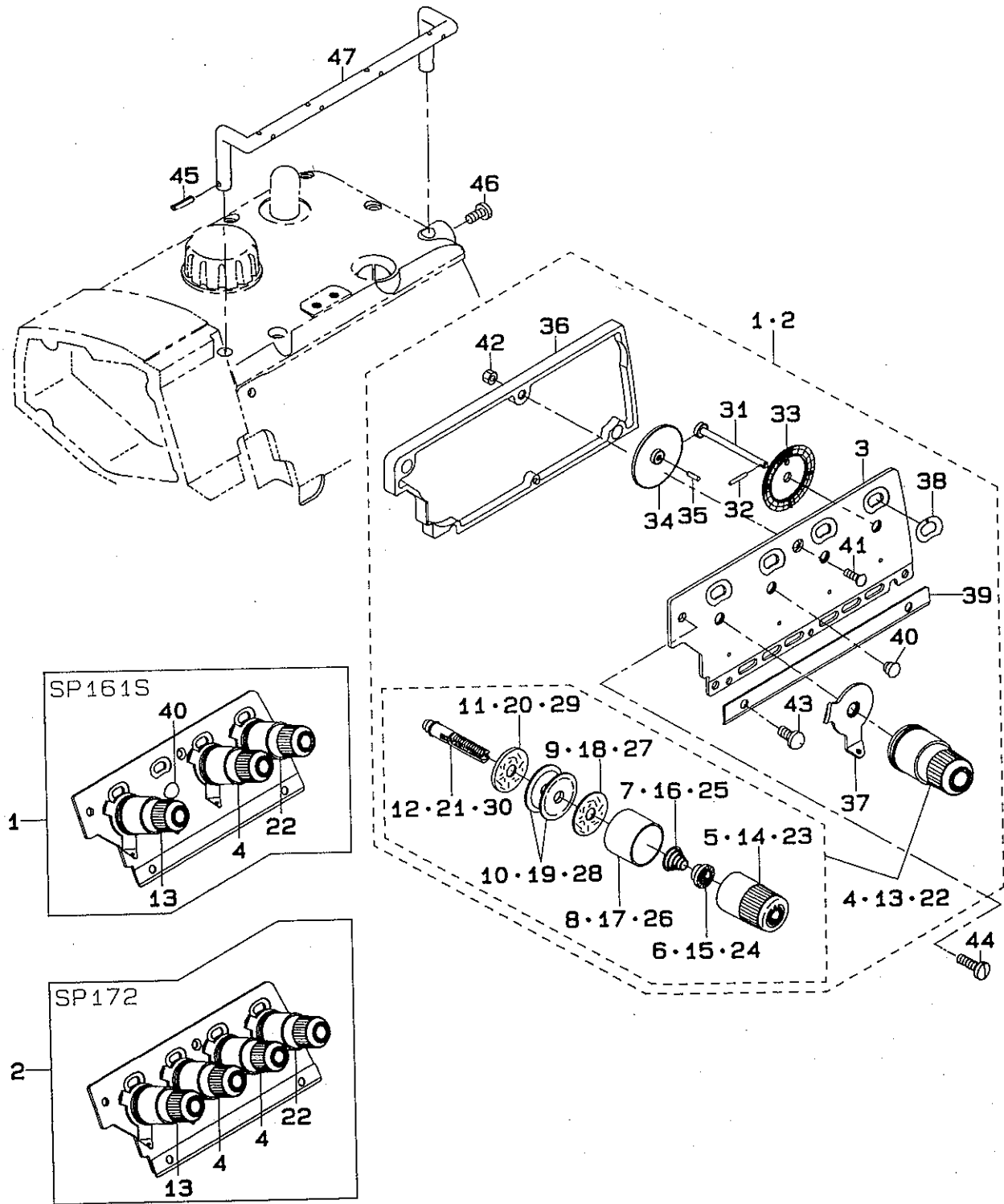



REF.NO	NOTE	PART NO.	DESCRIPTION	ヒンメイ	Qty
1	#01	121-80154	THREAD GUIDE PLATE ASM.	イトアンナイハン クミ	1
2	#02	121-80253	THREAD GUIDE PLATE ASM.	イトアンナイハン クミ	1
3		121-26207	THREAD GUIDE PLATE	イトアンナイハン	(1)
4		121-26959	KNOB ASM., YELLOW	イトチョウツツマミ キ クミ	(2)
5		121-26900	KNOB, YELLOW	イトチョウツツマミ キ	(1)
6		B3112-704-000	TENSION SPRING BUSHING	ハンネ プッシュ	(1)
7		B3102-804-000	TENSION SPRING, YELLOW	イトチヨウシハンネ (キイロ)	(1)
8		121-26702	TENSION DISK PRESSER	チョウツチラ オサエ	(1)
9		B3120-704-000	THREAD TENSION SPRING FELT	イトチヨウシハンネサ フエルト	(1)
10		B3126-012-000	THREAD TENSION DISK	イトチヨウシチラ	(2)
11		B3120-352-000	THREAD TENSION SPRING FELT	イトチヨウシハンネサ フエルト	(1)
12		121-26405	THREAD TENSION BAR	イトチョウツ ホウ	(1)
13		121-26850	KNOB ASM., RED	イトチョウツツマミ アカ クミ	(1)
14		121-26801	KNOB, RED	イトチョウツ ツマミ アカ	(1)
15		B3112-704-000	TENSION SPRING BUSHING	ハンネ プッシュ	(1)
16		B3101-804-000	TENSION SPRING, RED	イトチヨウシハンネ	(1)
17		121-26702	TENSION DISK PRESSER	チョウツチラ オサエ	(1)
18		B3120-704-000	THREAD TENSION SPRING FELT	イトチヨウシハンネサ フエルト	(1)
19		B3126-012-000	THREAD TENSION DISK	イトチヨウシチラ	(2)
20		B3120-352-000	THREAD TENSION SPRING FELT	イトチヨウシハンネサ フエルト	(1)
21		121-26405	THREAD TENSION BAR	イトチョウツ ホウ	(1)
22		121-27056	KNOB ASM., BLUE	イトチョウツツマミ アオ クミ	(1)
23		121-27007	KNOB, BLUE	イトチョウツツマミ アオ	(1)
24		B3112-704-000	TENSION SPRING BUSHING	ハンネ プッシュ	(1)
25		B3103-804-000	TENSION SPRING, BLUE	イトチヨウシハンネ (アオ)	(1)
26		121-26702	TENSION DISK PRESSER	チョウツチラ オサエ	(1)
27		B3120-704-000	THREAD TENSION SPRING FELT	イトチヨウシハンネサ フエルト	(1)
28		B3126-012-000	THREAD TENSION DISK	イトチヨウシチラ	(2)
29		B3120-352-000	THREAD TENSION SPRING FELT	イトチヨウシハンネサ フエルト	(1)
30		121-26405	THREAD TENSION BAR	イトチョウツ ホウ	(1)
31		121-27403	SCALE SHAFT	メモリシク	(1)
32		121-27502	SCALE SHAFT PIN	メモリシク ヒオン	(1)
33		121-27601	SCALE GEAR	メモリハク ルマ	(1)
34		121-27700	GEAR	ニタン ハク ルマ	(1)
35		121-27809	GEAR SHAFT	ハク ルマシク	(1)
36		121-27957	SCALE CASE ASM.	メモリケース クミ	(1)
37		121-26504	NEEDLE THREAD GUIDE	ハリイトチョウツ サライトアンナイ	(1)
38		121-28203	SCALE SIDE PLATE	メモリ マト イタ	(1)
39		121-28302	THREAD LOOPER GUIDE	ルハートカイト	(1)
40	#01	TA-0620504-R0	CAP	トメセン	(1)
41		SS-2090830-SL	SCREW	マルサラネジ	(1)
42		NS-6090310-SP	NUT 9/64-40	ロツカクナツト 9/64-40	(1)
43		SS-7110740-TL	SCREW 11/64-40 L= 7.0	マルヒラネジ 11/64-40 L=7	(1)
44		SS-7111410-TK	SCREW 11/64-40 L=14	マルヒラネジ 11/64-40 L=14	2
45		PS-0300132-KH	SPRING PIN 3X13	スプリングヒオン	1
46		SS-7110910-TP	SCREW 11/64-40 L= 8.5	マルヒラネジ 11/64-40 L=8.5	1
47		121-26108	CENTER THREAD GUIDE	チュウカン イトアンナイ	1

Note (注記) #01....FOR SP161S800M040  
#02....FOR SP172S900MADC

SP161S800M040 用  
SP172S900MADC 用

# 11. LOWER KNIFE COMPONENTS

下メス関係

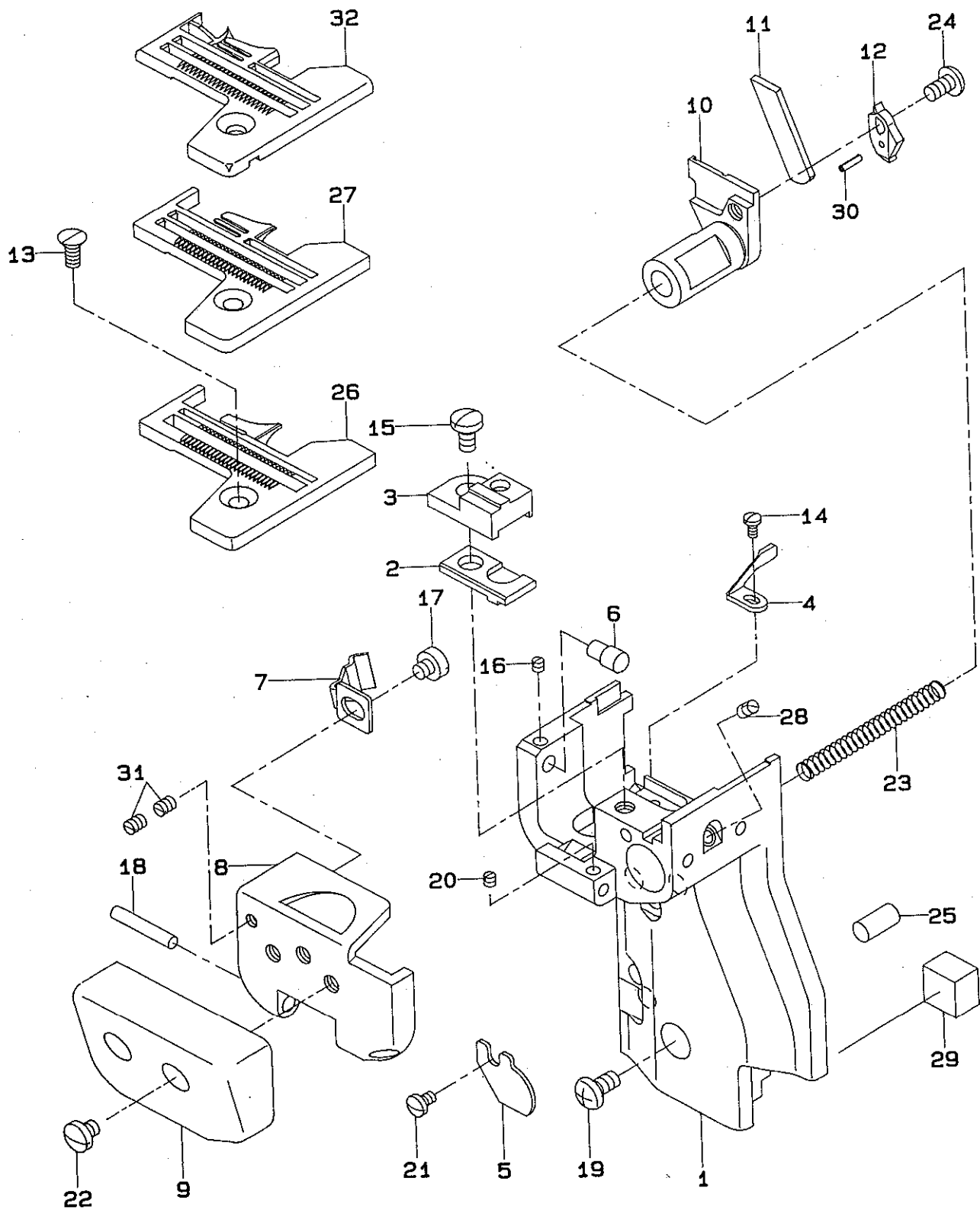

REF.NO	NOTE	PART NO.	DESCRIPTION	ヒ シ メ イ	Qty
1		122-19101	CYLINDER BRACKET	シリンダー フラケット	1
2		122-19903	THROAT PLATE BASE, LOWER	ハリイタタイ ジタ	1
3		122-19804	THROAT PLATE BASE, UPPER	ハリイタ タイウエ	1
4		122-40701	NEEDLE GUARD	ハリウケ	1
5		122-20109	SPRING STOPPER	シタメス ハネ トメイタ	1
6		122-19606	PIN	シリンダー カハ トメピン	1
7		122-19507	SPRING	シリンダー カハ ハネ	1
8		122-19200	COVER BASE	シリンダー カハ タイ	1
9		122-19358	CYLINDER COVER ASM.	シリンダー カハ クミ	1
10		122-20000	LOWER KNIFE SLIDE STUD	シタメス スライド シク	1
11		122-20307	LOWER KNIFE	シタメス	1
12		122-20208	LOWER KNIFE PRESSER PRATE	シタメス オサエ	1
13		SS-2110910-SL	SCREW 11/64-40 L=9	マルサラネジ 11/64-40 L=8.5	1
14		SS-7060510-SP	SCREW 3/32-56 L=4.8	マルヒラネジ 3/32-56 L=4.8	1
15		SS-7110840-SP	SCREW 11/64-40 L=7.8	マルヒラネジ 11/64-40 L=7.8	1
16		SS-8080310-TP	SCREW 1/8-44 L=2.8	トメネジ 1/8-44 L=2.8	1
17		SS-6110480-SP	SCREW 11/64-40 L=4.3	ヒラネジ 11/64-40 L=4.3	1
18		111-11705	WIPER SOLENOID PIN	ワイパ ソレノイド シク	1
19		SS-4120915-SP	SCREW 3/16-28 L=9	ナハネジ 3/16-28 L=9	3
20		SS-8080310-TP	SCREW 1/8-44 L=2.8	トメネジ 1/8-44 L=2.8	1
21		SS-7080520-SP	SCREW 1/8-44 L=4.9	マルヒラネジ 1/8-44 L=4.9	1
22		SS-7110510-SP	SCREW 11/64-40 L=5	マルヒラネジ 11/64-40 L=5	2
23		122-20505	SPRING	シタメス スライド シク ハネ	1
24		SS-4110815-SP	SCREW 11/64-40 L=8	ナハネジ 11/64-40 L=8	1
25		122-19705	PIN	フラケット コチピン	2
26	#01	R4200-KOE-D00	THROAT PLATE	ハリイタ	1
27	#02	R4305-KOE-E00	THROAT PLATE	ハリイタ	1
28		SS-8110422-TP	SCREW 11/64-40 L=4	トメネジ 11/64-40 L=4	1
29		122-20604	BRACKET	フラケット セン	1
30		PS-0150065-KP	SPRING PIN 1.5X6	スプリング ピン 1.5X6	1
31		SS-8080410-TP	SCREW 1/8-44 L=3.5	トメネジ 1/8-44 L=3.5	2
32	#03	R4305-KOE-E0A	THROAT PLATE	ハリイタ	1

Note (注記) #01....FOR SP161S800M040  
#02....FOR SP172S900MADC  
#03....P05/Q01 EXCHANGING PARTS

SP161S800M040 用  
SP172S900MADC 用  
P05/Q01 交換部品

12. UPPER KNIFE COMPONENTS

上メス関係

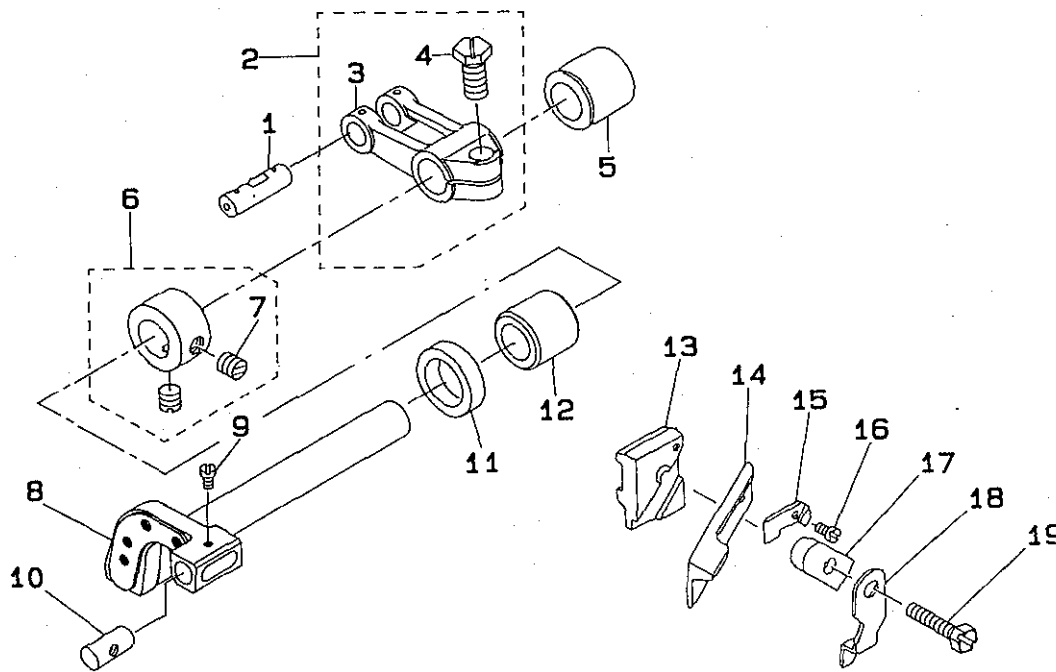

REF.NO	NOTE	PART NO.	DESCRIPTION	ヒンメイ	Qty
1	#01	118-23804	CRANK PIN C	オクリフタマタ クランクピン C	1
2		121-32254	FEED FORKED ARM ASM.	ウエメス フタマタ ウテ <sup>ク</sup> クミ	1
3		121-32205	UPPER KNIFE DRIVING ARM.	ウエメス フタマタ ウテ <sup>ク</sup>	(1)
4		SS-9661230-CP	SCREW 1/4-40 L=12	ロツカクホルト 1/4-40 L=12	(1)
5		121-32502	BUSHING, REAR	ウエメスジ <sup>ク</sup> ウシロメタル	1
6		CS-1111019-SH	THRUST COLLAR D=11.11 W=10	スラストウケ D=11.11 W=10	1
7		SS-8660330-SP	SCREW 1/4-40 L= 3.0	トメネジ <sup>ク</sup> 1/4-40 L=3	(2)
8		121-32304	KNIFE DRIVING ARM SHAFT	メス ウテ <sup>ク</sup> ジ <sup>ク</sup>	1
9		SS-4060310-SP	SCREW 3/32-56 L=2.5	ナ <sup>ハ</sup> ネジ <sup>ク</sup> 3/32-56 L=2.5	1
10		115-65801	UPPER KNIFE GUIDE SHAFT	ウラメスカ <sup>ハ</sup> イ <sup>ク</sup> ジ <sup>ク</sup>	1
11		115-66809	OIL SEAL	ウラメスジ <sup>ク</sup> オイルシール	1
12		121-32403	BUSHING, FRONT	ウエメスジ <sup>ク</sup> マエメタル	1
13		115-98000	UPPER KNIFE SUPPORT	ウラメスササエ	1
14		118-45807	UPPER KNIFE	ウラメス	1
15		115-65702	WASHER	ウラメスオサエ サ <sup>カ</sup> ネ	1
16		SS-4060310-SP	SCREW 3/32-56 L=2.5	ナ <sup>ハ</sup> ネジ <sup>ク</sup> 3/32-56 L=2.5	1
17		115-65504	UPPER KNIFE PRESSER PLATE	ウラメスオサエ	1
18		118-48405	UPPER KNIFE COVER	ウラメスカ <sup>ハ</sup> ー	1
19		SS-9111610-SP	SCREW 11/64-40 L=16	ロツカクホルト 11/64-40 L=16	1

Note (注記) #01....SELECTING PART FOR FIT TOLERANCE

選択かん合部品

13. NEEDLE COOLING MECHANISM COMPONENTS

針冷却装置関係

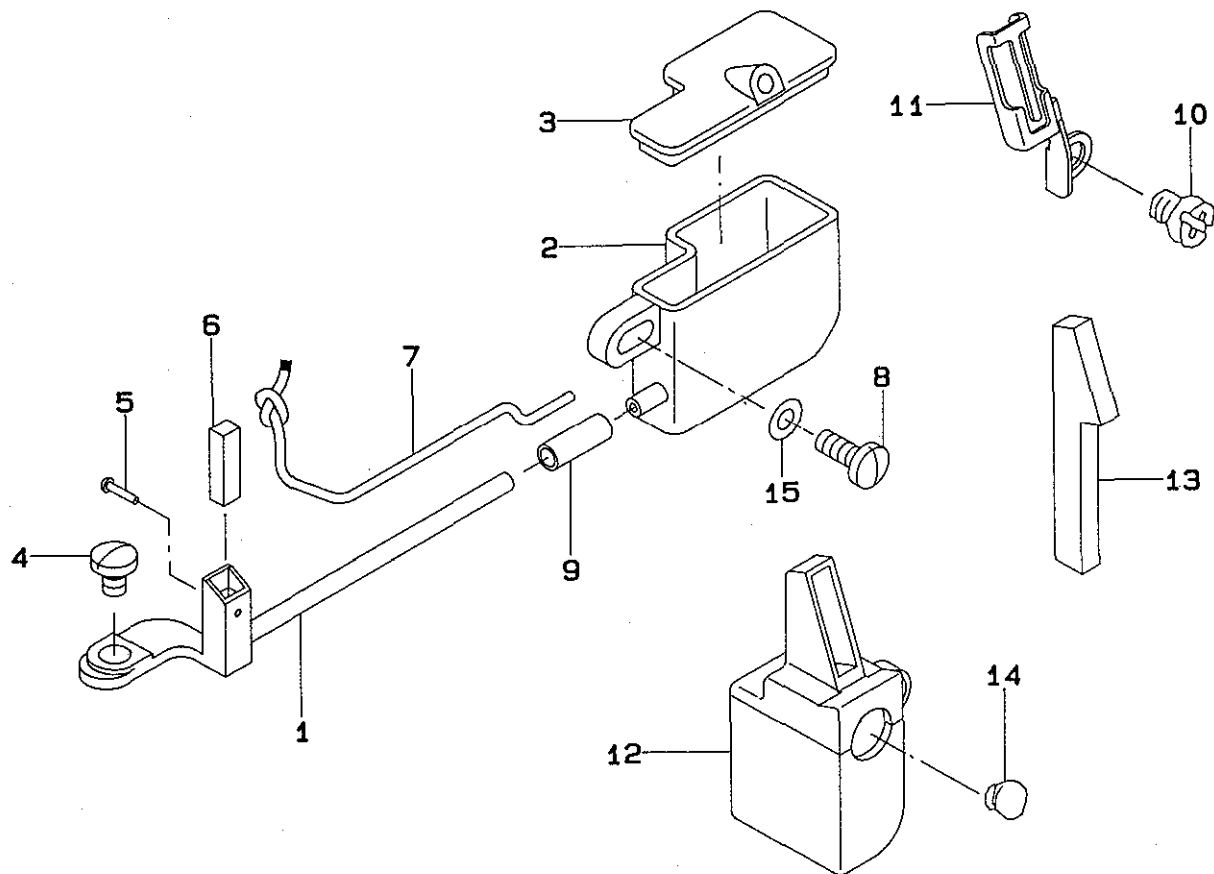

REF.NO	NOTE	PART NO.	DESCRIPTION	ヒ	ン	メ	イ	Qty
1		122-24853	NEEDLE COOLER ASM.	ハリ	レイ	キャク	キケツコウ	1
2		122-24606	TANK	ハリ	レイ	キャク	タンク	1
3		122-24705	TANK COVER	ハリ	レイ	キャク	タンク フタ	1
4		SS-7090540-TP	SCREW 9/64-40 L=5	マル	ヒラ	ネジ	9/64-40 L=5	1
5		118-56101	NEEDLE COOLER PIN	ハリ	レイ	キャク	フェルトトメピン	1
6		122-25009	FELT	ハリ	レイ	キャク	フェルト	1
7		CQ-2000000-00	OIL WICK	ユ	シ			0.15
8		SS-7090910-SP	SCREW 9/64-40 L= 8.5	マル	ヒラ	ネジ	9/64-40 L=8.5	1
9		BT-0400251-ED	TUBE HOSE, GREEN	ウ	レ	タン	ホース ミト	0.02
10		SS-4110915-SP	SCREW 11/64-40 L=9	ナ	ヘ	ネジ	11/64-40 L=9	1
11		121-38400	PRESSER	ハリ	イト	フェルト	オサ	1
12		121-38152	SILICON TANK ASM.	ハリ	イト	タンク	クミ	1
13		121-38301	FELT	ハリ	イト	フェルト		1
14		TA-0950806-R0	RUBBER PLUG	ト	メ	セ		1
15		WP-0371026-SD	WASHER 3.7X7X1	ヒ	ラ	サ	ガ	1

# 14. LUBRICATION MECHANISM COMPONENTS

## 給油装置関係

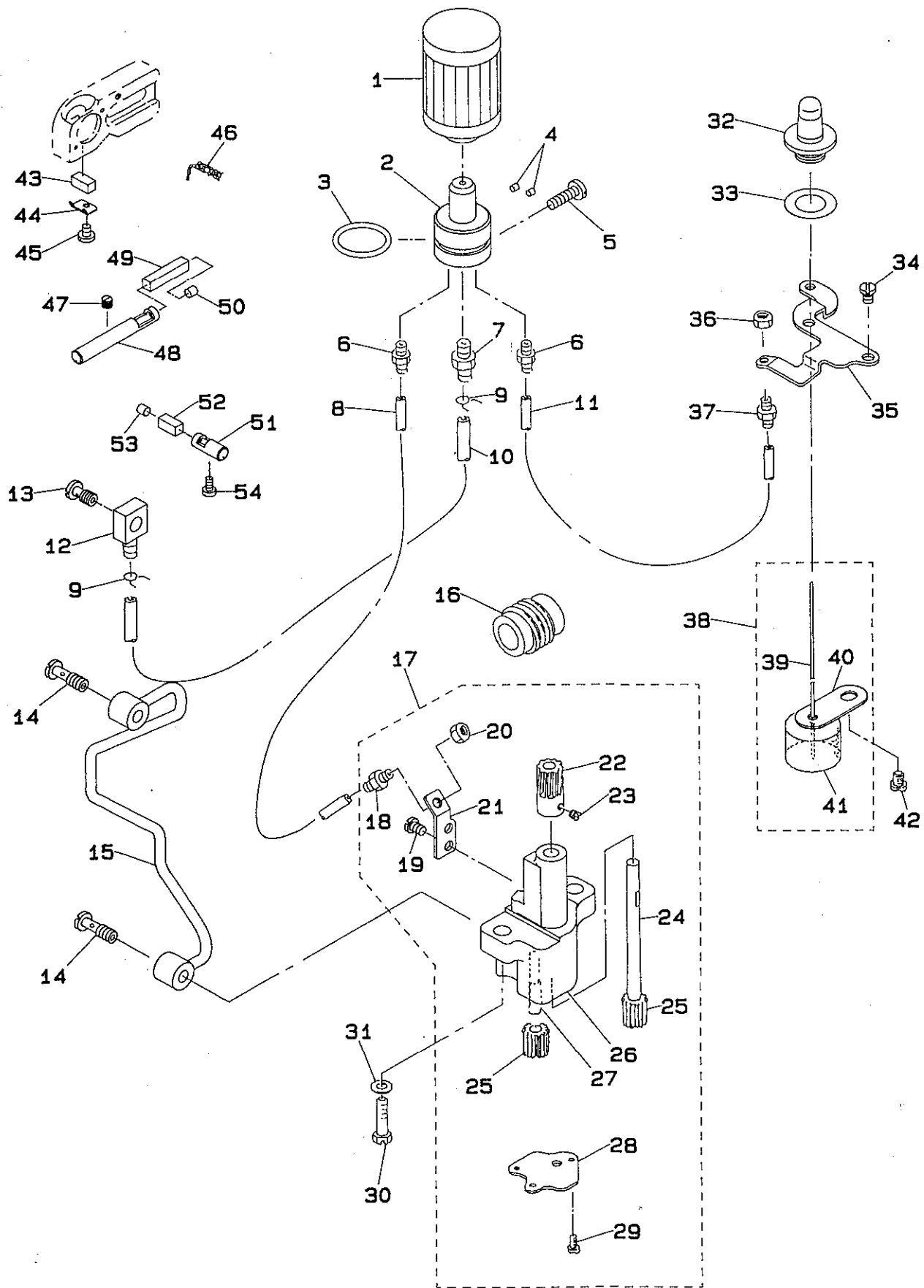

REF.NO	NOTE	PART NO.	DESCRIPTION	ヒンメイ	Qty
1		118-43208	CARTRIDGE FILTER	カートリッジフィルター	1
2		121-29706	FILTER GUIDE	フィルターガイド	1
3		RO-2182401-00	RUBBER RING	Oリング	1
4		TA-0290301-MO	PLUG 2.9X3.2X3	トメセン D=2.9X3.2 L=3	2
5		SS-7121610-SP	SCREW 3/16-28 L=15.5	マルヒラネジ 3/16-28 L=15.5	1
6		SQ-1110451-MZ	CONNECTING SCREW	ハ°イフ°レンケツネジ	2
7		SQ-1150451-MZ	CONNECTING SCREW	チユープ°レンケツネジ	1
8		BT-0500300-EG	OIL TUBE	チユープ	0.2
9		101-26803	OIL TUBE HOLDER	ハ°イフ°トメ	2
10		BT-0500300-EA	OIL TUBE	ウレタンチユープ	0.3
11		BT-0500300-EA	OIL TUBE	ウレタンチユープ	0.2
12		SQ-0000451-MZ	CONNECTING SCREW	ハ°イフ°レンケツネジ	1
13		SQ-1150441-SD	CONNECTING SCREW	ハ°イフ°レンケツネジ	1
14		SQ-1150454-SD	CONNECTING SCREW	ハ°イフ°レンケツネジ	2
15		122-18152	OIL PIPE ASM.	キユウエハ°イフ° クミ	1
16		121-29102	WORM	ウォーム	1
17		121-29250	OIL PUMP ASM.	キユウエホ°ンフ° タイケツゴウ	1
18		SQ-1110451-MZ	CONNECTING SCREW	ハ°イフ°レンケツネジ	(1)
19		SS-4110615-SP	SCREW 11/64-40 L=6	ナヘ°ネジ	(2)
20		NS-6110310-SP	NUT 11/64-40	ロツカクナツト 11/64-40	(1)
21		121-29300	CONNECTING SCREW BRACKET	ウォーム トシユツク°チ ササエ	(1)
22		118-41707	WORM GEAR	ウォームハク°ルマ	(1)
23		SS-8110410-TP	SCREW 11/64-40 L= 3.5	トメネジ 11/64-40 L=3.5	(2)
24		118-41806	GEAR PUMP SHAFT, LARGE	キ°ヤホ°ンフ°シク° タ°イ	(1)
25		118-40303	OIL PUMP PINION	ホ°ンフ°ヨウ° ヒ°ニオン	(2)
26		121-29201	OIL PUMP	キユウエホ°ンフ° タイ	(1)
27		118-40402	GEAR PUMP SHAFT	キ°ヤホ°ンフ°シク° ショ-	(1)
28		118-43406	COVER	ホ°ンフ°シツフタ	(1)
29		SS-6090650-SP	SCREW 9/64-40 L=6	ヒラネジ 9/64-40 L=6	(3)
30		SS-9152130-CP	SCREW 15/64-28 L=20.5	ロツカクホ°ルト 15/64-28	2
31		WP-0651056-SH	WASHER 6.5X11X1	ヒラサ°カ°ネ 6.5X11X1	2
32		121-30100	OIL GAUGE	オイルゲ°ーシ	1
33		121-30209	RUBBER PACKING	オイルゲ°ーシ°ハ°ッキン	1
34		SS-4120615-SP	SCREW 3/16-28 L=6	ナヘ°ネジ 3/16-28 L=6	2
35		121-29607	OILING EXIT SUPPORT	トシユツク°チ ササエ	1
36		NS-6110310-SP	NUT 11/64-40	ロツカクナツト 11/64-40	1
37		SQ-1110451-MZ	CONNECTING SCREW	ハ°イフ°レンケツネジ	1
38		121-29854	FLOAT ASM.	ウキコ クミ	1
39		121-29904	OIL GAUGE BAR	エリョウシジ°ホ°ウ	(1)
40		121-30001	FLOAT SUPPORT	ウキコササエ	(1)
41		121-29805	FLOAT	ウキコ	(1)
42		SS-4150715-SP	SCREW 15/64-28 L=7	ナヘ°ネジ 15/64-28 L=7	1
43		121-30803	OIL FELT	ウエル°ハ°°キユウエフ°ェルト	1
44		121-30704	FELT HOLDER	ウエル°ハ°°キユウエフ°ェルト オサエ	1
45		SS-7080310-SP	SCREW 3/32-56 L=3	マルヒラネジ 3/32-56 L=3	1
46		CQ-2020000-00	OIL WICK	エシン	0.1
47		SS-8120410-SP	SCREW	トメネジ	1
48		121-30308	OILING PIN	ハリ°キユウエヒ°ン	1
49		121-30407	OIL FELT	ハリ°キユウエヒ°ン°フェルト	1
50		TA-0400301-MO	PLUG D=4X4.5 L=3	トメセン D=4X4.5 L=3	1
51		121-30506	OILING PIN	ウエル°ハ°°キユウエヒ°ン	1
52		121-30605	OIL FELT	ウエル°ハ°°キユウエヒ°ン°フェルト	1
53		TA-0400301-MO	PLUG D=4X4.5 L=3	トメセン D=4X4.5 L=3	1
54		SS-6121020-SP	SCREW 3/16-28 L= 9.5	ヒラネジ 3/16-28 L=9.5	1

15. SEMI-SUNKEN TYPE TABLE COMPONENTS

卓上式テーブル関係

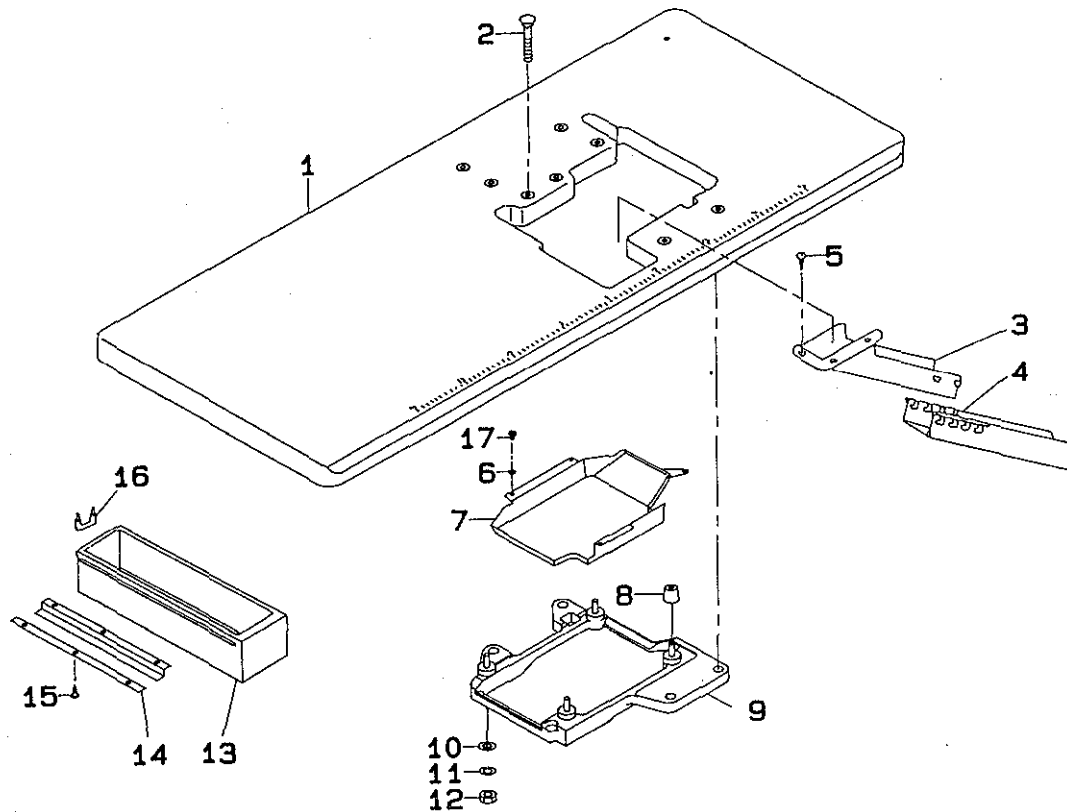

REF.NO	NOTE	PART NO.	DESCRIPTION	ヒ シ ム イ	Qty
1		122-21602	TABLE(SEMI-SUNKEN)	テーブル(タクシヨウシキ)	1
2		115-71601	BOLT A	ウケイタボルト A	4
3		119-68609	CLOTH WASTE CHUTE (TABLE)	ヌノクスシユート ウイ (タクシヨウ)	1
4		119-60002	CLOTH WASTE CHUTE, LOWER (BENCH)	ヌノクスシユートシタ (タクシヨウ)	1
5		SK-2351600-SC	SCREW WASTE	マルモクネシ	3
6		WP-0370316-SD	WASHER 3.7X8X0.3	ヒラサカネ 3.7X8X0.3	4
7		122-21800	COOLING FAN CASE	ソウフウ ケース	1
8		115-71403	RUBBER CUSHION	ホ-ジシヨム	4
9		122-21750	FRAME SUPPORT PLATE ASM.	フレームウケイタクミ	1
10		WP-1102016-SC	WASHER 11X21X2	ヒラサカネ 11X21X2	4
11		WS-1002560-KR	SPRING WASHER 10X18X2.5	ハネサカネ 10X18X2.5	4
12		NS-6240630-SN	NUT 3/8-18	ノツカクナツト 3/8-18	4
13		111-55108	DRAWER	ヒキタシ	1
14		111-55207	DRAWER SUPPORT	ヒキタシ ササエ	2
15		SK-3311500-SC	WOOD SCREW D=3.1 L=15	マルモクネシ D=3.1 L=15	6
16		D8204-555-D00	DRAWER STOPPER	ヒキタシストツハ-	1
17		SS-6090630-SP	SCREW 9/64-40 L=6	ヒラネシ 9/64-40 L=6	4



16. THREAD STAND COMPONENTS

糸立装置関係

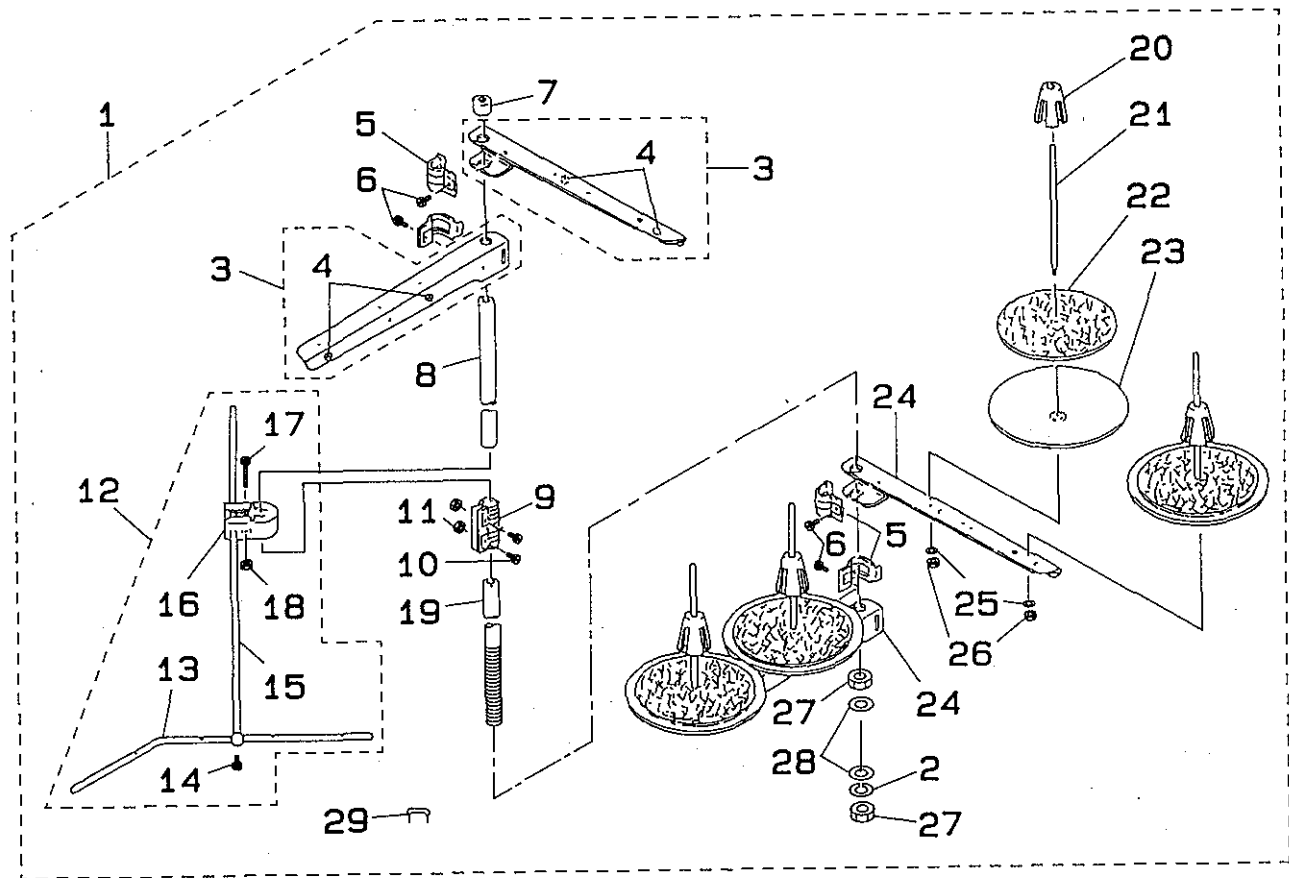

REF.NO	NOTE	PART NO.	DESCRIPTION	ヒンメイ	Qty
1		119-57750	THREAD STANDING DEVICE ASM.	イトタテソウチ (クミ)	1
2		WS-1643202-KR	SPRING WASHER	ハネサカネ 16.4X26.6X3.2	(1)
3		B3302-704-LCB	THREAD GUIDE ASM.	イトタテウチ B クミ	(2)
4		B3319-704-L00	THREAD GUIDE	イトミチ	(4)
5		B3318-704-L00-A	THREAD GUIDE ARM JOINT	イトタテウチ シメカナク	(4)
6		SM-6061610-SC	SCREW M6 L=16	ヒラコネジ M6 L=15	(4)
7		111-84108	SPOOL REST ROD RUBBER CAP	イトタテホウ ホココム	(1)
8		119-57503	SPOOL REST ROD, UPPER	イトタテホウ (ウエ)	(1)
9		B3305-704-000-A	SPOOL REST ROD JOINT	イトタテホウ ツキテ	(1)
10		SM-4051405-SE	SCREW M5X0.8 L=14	ナメコネジ M5X0.8 L=14	(2)
11		NM-6050001-SE	NUT M5X0.8	ロツカクナツ M5X0.8 1シュ	(2)
12		B3309-704-0A0	THREAD GUIDE ARM ASM.	イトタテ イトアンナイ ウチ クミ	(1)
13		B3311-804-000	LOWER THREAD GUIDE	イトタテ イトアンナイ シタ	(1)
14		SS-7110540-SP	SCREW 11/64-40 L=5	マルヒラネジ 11/64-40 L=5	(1)
15		B3309-704-000	THREAD GUIDE ARM	イトタテ イトアンナイ ウチ	(1)
16		B3304-704-000-A	THREAD GUIDE ARM HOLDER	イトアンナイウチ ホルター	(1)
17		SM-6053000-SE	SCREW M5X0.8 L=30	ヒラコネジ M5X0.8 30	(1)
18		NM-6050001-SE	NUT M5X0.8	ロツカクナツ M5X0.8 1シュ	(1)
19		119-57404	SPOOL REST ROD, LOWER	イトタテホウ (シタ)	(1)
20		111-84009	SPOOL RETAINER	イトマキ フレトメ	(4)
21		B3320-704-L00-A	SPOOL PIN	イトマキウケホウ	(4)
22		B3311-012-000	SPOOL REST CUSHION	イトマキウケサ	(4)
23		111-83902	SPOOL REST	イトマキ ウケサラ	(4)
24		111-83803	THREAD GUIDE	イトタテウチ B	(2)
25		WS-0510002-KN	SPRING WASHER	ハネサカネ 5.1X9.2X1.3	(4)
26		NM-6050001-SE	NUT M5X0.8	ロツカクナツ M5X0.8 1シュ	(4)
27		B3317-704-000	NUT C15	イトタテホウ トメナツト	(2)
28		WP-1702600-S0	WASHER 17X30X2.6	ヒラサカネ 17X30X2.6	(2)
29		MA0-11532000	CORD STAPLE	コート ステツプル	(3)

17. SPECIAL ORDER PARTS COMPONENTS

特別注文部品関係

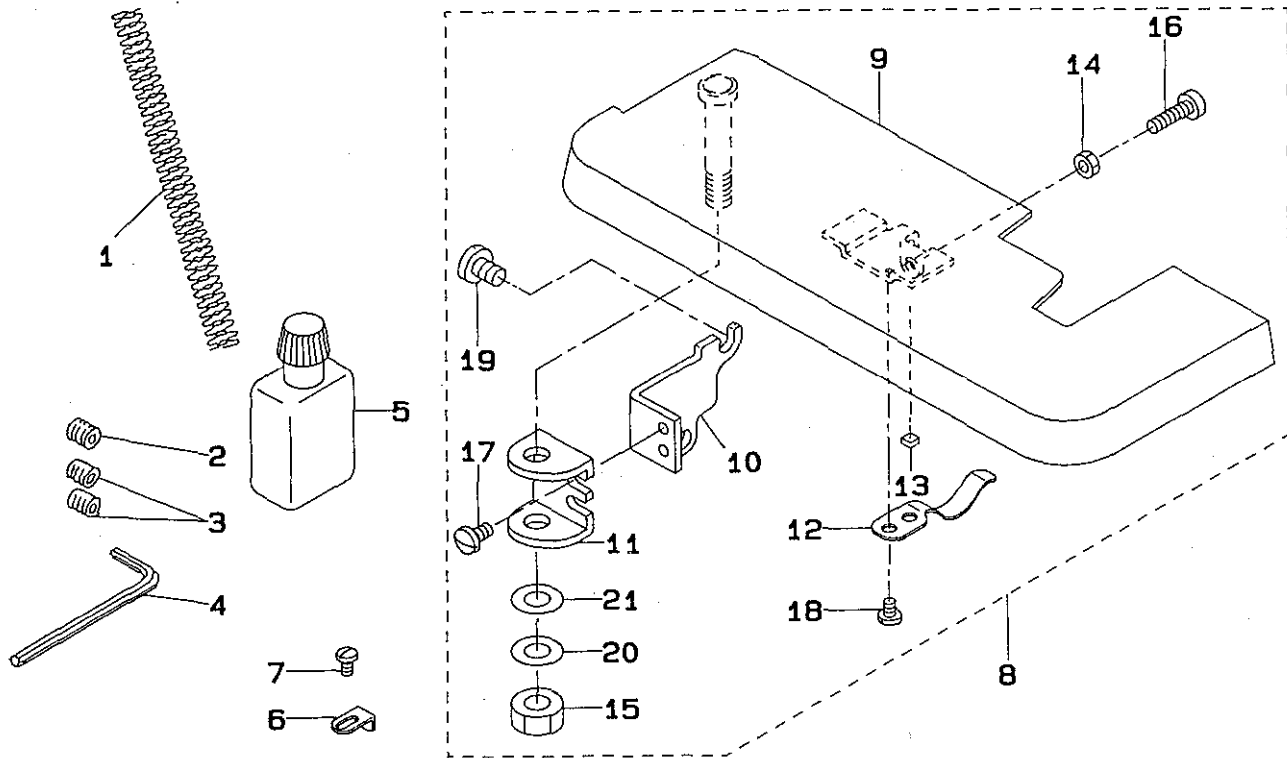

REF.NO	NOTE	PART NO.	DESCRIPTION	ヒンメイ	Qty
1		B1515-804-000-A	PRESSER SPRING	オサI ハネ	1
2	#01	SS-8080322-TP	SCREW 1/8-44 L=3.2	トメネジ 1/8-44 L=3.2	1
3	#02	SS-8080322-TP	SCREW 1/8-44 L=3.2	トメネジ 1/8-44 L=3.2	2
4		B9112-804-000	SPANNER	ハリ トメネジ スパナ	1
5		B9135-123-0BQ	SILICON OIL LUBRICANT ASM. (30	エスレンヨ-キ (30CC)	1
6		118-98103	PRESSER FOOT AUXILIARY PLATE	オサIホシヨイタ	1
7		SS-4080620-TP	SCREW 1/8-44 L=6	ナハネジ 1/8-44 L=6	1
8		122-26155	CLOTH BASE ASM.	ヌメアイクミ	1
9		122-26163	CLOTH BASE ASM.	ヌメアイクミ	(1)
10		122-26304	FITTING PLATE A	ヌメアイトリツケイタ A	(1)
11		122-26403	FITTING PLATE B	ヌメアイトリツケイタ B	(1)
12		122-26502	CLOTH BASE SPRING	ヌメアイハネ	(1)
13		118-06304	PLUG	ハリイタツタ	(1)
14		NS-6110310-SP	NUT 11/64-40	ロツカクナツト 11/64-40	(1)
15		NS-6680320-SP	NUT 9/32-28	ロツカクナツト 9/32-28	(2)
16		SS-6111610-SP	SCREW 11/64-40 L=16	ヒラネジ 11/64-40 L=16	(1)
17		SS-7110840-SP	SCREW 11/64-40 L=7.8	マルヒラネジ 11/64-40 L=7.8	(2)
18		SS-7090540-TP	SCREW 9/64-40 L=5	マルヒラネジ 9/64-40 L=5	(2)
19		SS-7150910-TP	SCREW	マルヒラネジ 15/64-28 L=9	(2)
20		WP-0841600-OE	WASHER 8.4X15.5X1.6	ヒラサカガネ 8.4X15.5X1.6	(1)
21		WZ-0850302-KO	WAVED WASHER 8.5X12.5X0.3	ナミカタサカガネ 8.5X12.5X0.3	1

Note (注記) #01...FOR SP151,SP161  
 #02...FOR SP172

SP151,SP161 用  
 SP172 用

18. SUBCLASSES

サブクラス

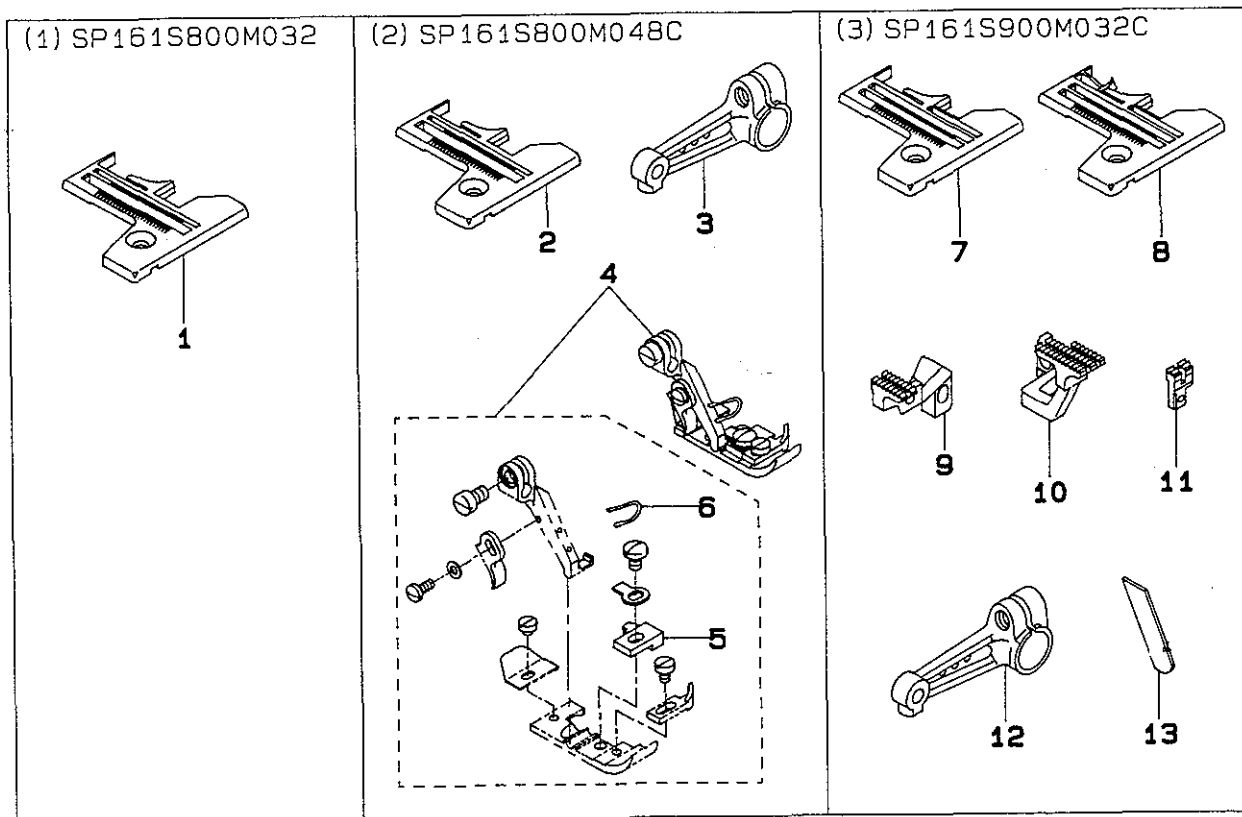

REF.NO	NOTE	PART NO.	DESCRIPTION	ヒンメイ	Qty
1		R4200-KOD-D00	THROAT PLATE	アリタ	1
2		R4200-KOF-D00	THROAT PLATE	アリタ	1
3		122-14607	UPPER LOOPER ARM D	ウエル-ハ°-ウテ° D	1
4		122-30462	PRESSER FOOT ASM.	オキエケツコ°ウ	1
5		B1509-804-C0A	STITCH TONGUE	イトスハ°リタ°イ	(1)
6		118-20701	FINGER GUARD	エビ°カ°ト°	(1)
7		R4300-KOD-E00	THROAT PLATE	アリタ	1
8	#01	R4300-KOD-E0A	THROAT PLATE	アリタ	1
9		122-35206	MAIN FEED DOG	シュ オクリハ°	1
10		122-36709	DIFFERENTIAL FEED DOG	フク オクリハ°	1
11	#01	122-38200	AUXILIARY FEED DOG	ホシ°ヨオクリハ°	1
12		122-14607	UPPER LOOPER ARM D	ウエル-ハ°-ウテ° D	1
13		122-20406	LOWER KNIFE	シタメス	1

Note (注記) #01.....P01/Q01 EXCHANGING PARTS

P01/Q01 交換部品

\*ALL PARTS NOT MENTIONED ABOVE ARE SAME AS THOSE OF SP161S800M040.  
上記以外の部品は、SP161S800M040 と共通です。

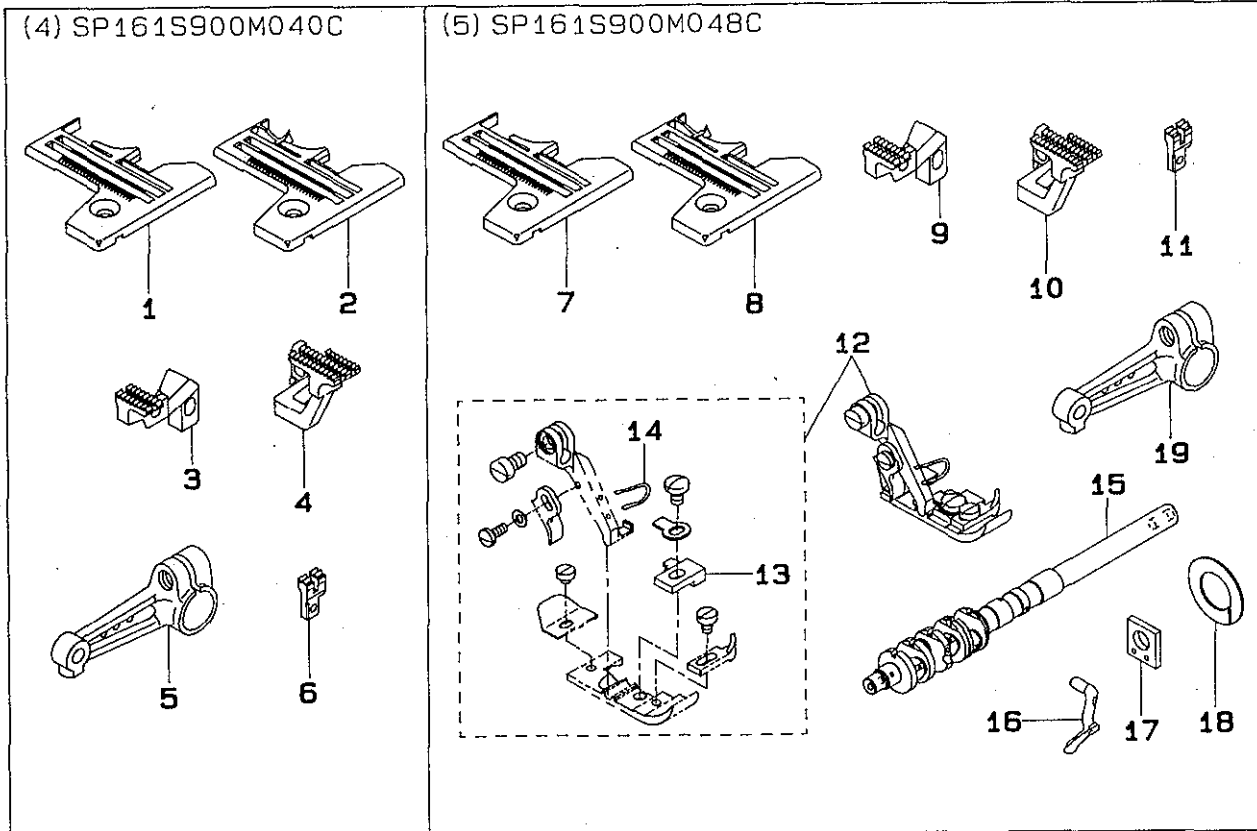

REF.NO	NOTE	PART NO.	DESCRIPTION	ヒソメイ	Qty
1		R4300-KOE-E00	THROAT PLATE	ハリイタ	1
2	#01	R4300-KOE-E0A	THROAT PLATE	ハリイタ	1
3		122-35206	MAIN FEED DOG	シュ オクリハ	1
4		122-36709	DIFFERENTIAL FEED DOG	フク オクリハ	1
5		122-14607	UPPER LOOPER ARM D	ウエルハ <sup>°</sup> -ウテ <sup>°</sup> D	1
6	#01	122-38200	AUXILIARY FEED DOG	ホシ <sup>°</sup> ヨクリハ	1
7		R4300-KOF-E00	THROAT PLATE	ハリイタ	1
8	#02	R4300-KOF-E0A	THROAT PLATE	ハリイタ	1
9		122-35206	MAIN FEED DOG	シュ オクリハ	1
10		122-36709	DIFFERENTIAL FEED DOG	フク オクリハ	1
11	#02	122-38200	AUXILIARY FEED DOG	ホシ <sup>°</sup> ヨクリハ	1
12		122-30462	PRESSER FOOT ASM.	オサエケツコ <sup>°</sup> ウ	1
13		B1509-804-COA	STITCH TONGUE	イトス <sup>°</sup> アリタ <sup>°</sup> イ	(1)
14		118-20701	FINGER GUARD	ユヒ <sup>°</sup> カ <sup>°</sup> -ト <sup>°</sup>	(1)
15		122-03709	MAIN SHAFT	シユジ <sup>°</sup> ク	1
16		122-47102	UPPER LOOPER	ウエルハ <sup>°</sup> -	1
17		118-93609	GAUGE	ウリルハ <sup>°</sup> カ <sup>°</sup> イト <sup>°</sup> ササ <sup>°</sup> イ <sup>°</sup> ケ <sup>°</sup> -ジ <sup>°</sup>	1
18		121-45108	STOPPER	ルハ <sup>°</sup> -ロツ <sup>°</sup> フレ <sup>°</sup> ト <sup>°</sup> メ	2
19		122-14607	UPPER LOOPER ARM D	ウエルハ <sup>°</sup> -ウテ <sup>°</sup> D	1

Note (注記) #01.....P02/Q01 EXCHANGING PARTS  
 #02.....P03/Q01 EXCHANGING PARTS

P02/Q01 交換部品  
 P03/Q01 交換部品

\*ALL PARTS NOT MENTIONED ABOVE ARE SAME AS THOSE OF SP161S800M040  
 上記以外の部品は、SP161S800M040 と共通です。

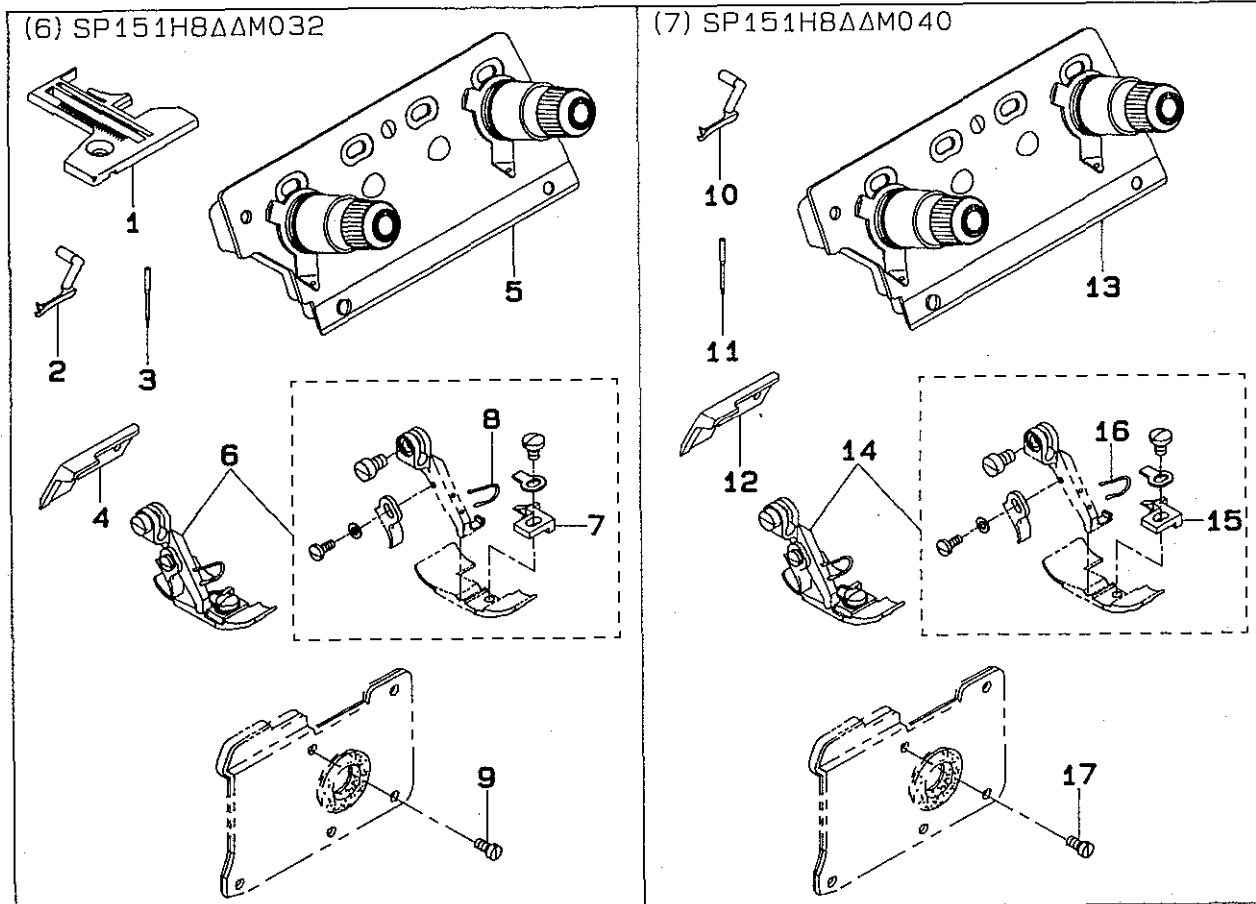

REF.NO	NOTE	PART NO.	DESCRIPTION	ヒ ン メ イ	Qty
1		R4200-KOD-D00	THROAT PLATE	ハリタ	1
2		122-47508	UPPER LOOPER	ウエカキルハロー	1
3		MDC-270B0900	NEEDLE DCX27 #9	ハリ DCX27 #9	1
4		118-45906	UPPER KNIFE	ウワメス	1
5		121-80352	THREAD GUIDE PLATE ASM.	イトアンナイハソクミ	1
6		119-92161	PRESSER FOOT ASM.	オサエ クミ	1
7		118-74807	STITCH TONGUE	イトスハリタノイ	(1)
8		118-20701	FINGER GUARD	ユビガード	(1)
9		SS-6090630-SP	SCREW 9/64-40 L=6	ヒラネジ 9/64-40 L=6	1
10		122-47508	UPPER LOOPER	ウエカキルハロー	1
11		MDC-270B0900	NEEDLE DCX27 #9	ハリ DCX27 #9	1
12		118-45906	UPPER KNIFE	ウワメス	1
13		121-80352	THREAD GUIDE PLATE ASM.	イトアンナイハソクミ	1
14		119-92161	PRESSER FOOT ASM.	オサエ クミ	1
15		118-74807	STITCH TONGUE	イトスハリタノイ	(1)
16		118-20701	FINGER GUARD	ユビガード	(1)
17		SS-6090630-SP	SCREW 9/64-40 L=6	ヒラネジ 9/64-40 L=6	1

\*ALL PARTS NOT MENTIONED ABOVE ARE SAME AS THOSE OF SP161S800M040.  
上記以外の部品は、SP161S800M040 と共通です。

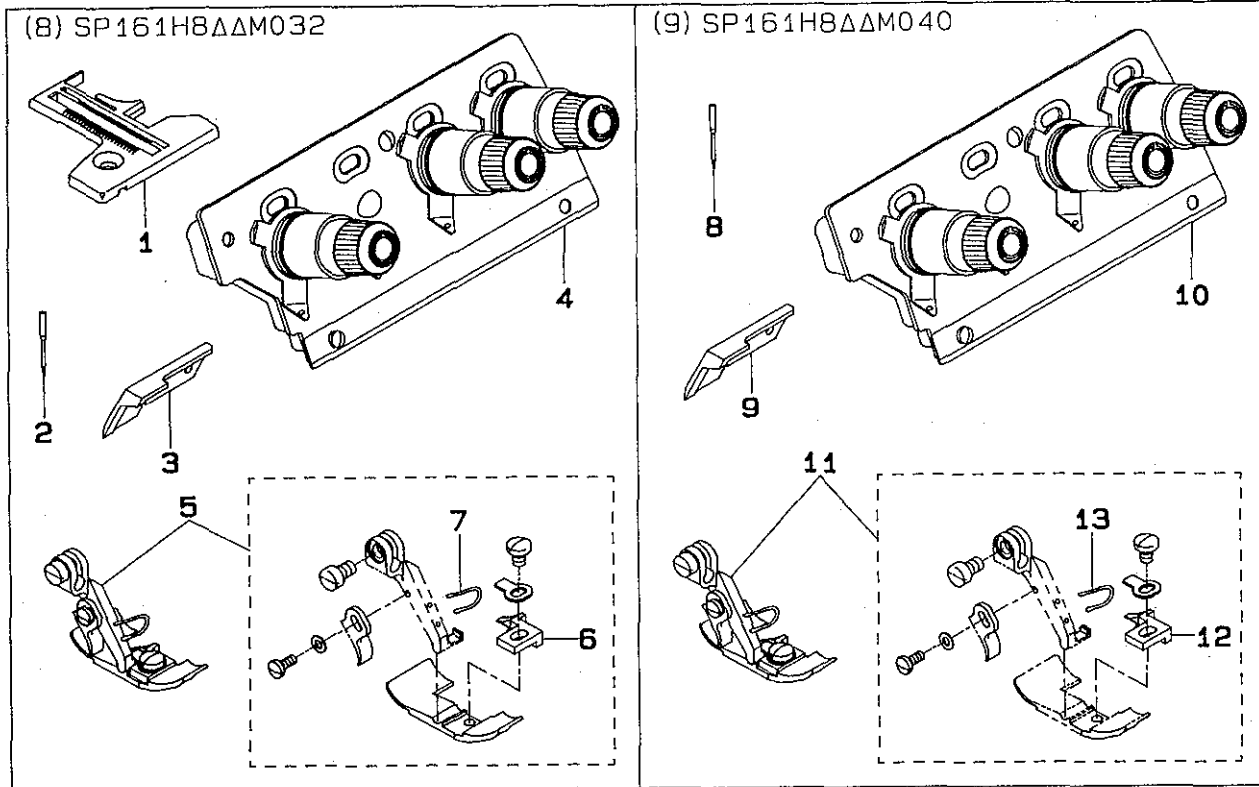

REF.NO	NOTE	PART NO.	DESCRIPTION	ヒンメイ	Qty
1		R4200-KOD-D00	THROAT PLATE	ハリタ	1
2		MDC-270B0900	NEEDLE DCX27 #9	ハリ DCX27 #9	1
3		118-45906	UPPER KNIFE	ウラメス	1
4		121-80550	THREAD GUIDE PLATE ASM.	イトアンナイハクミ	1
5		119-92161	PRESSER FOOT ASM.	オサエ クミ	1
6		118-74807	STITCH TONGUE	イトスハリタイ	(1)
7		118-20701	FINGER GUARD	ユビガード	(1)
8		MDC-270B0900	NEEDLE DCX27 #9	ハリ DCX27 #9	1
9		118-45906	UPPER KNIFE	ウラメス	1
10		121-80550	THREAD GUIDE PLATE ASM.	イトアンナイハクミ	1
11		119-92161	PRESSER FOOT ASM.	オサエ クミ	1
12		118-74807	STITCH TONGUE	イトスハリタイ	(1)
13		118-20701	FINGER GUARD	ユビガード	(1)

\*ALL PARTS NOT MENTIONED ABOVE ARE SAME AS THOSE OF SP161S800M040.  
 上記以外の部品は、SP161S800M040 と共通です。

(10) SP172S800MAAC

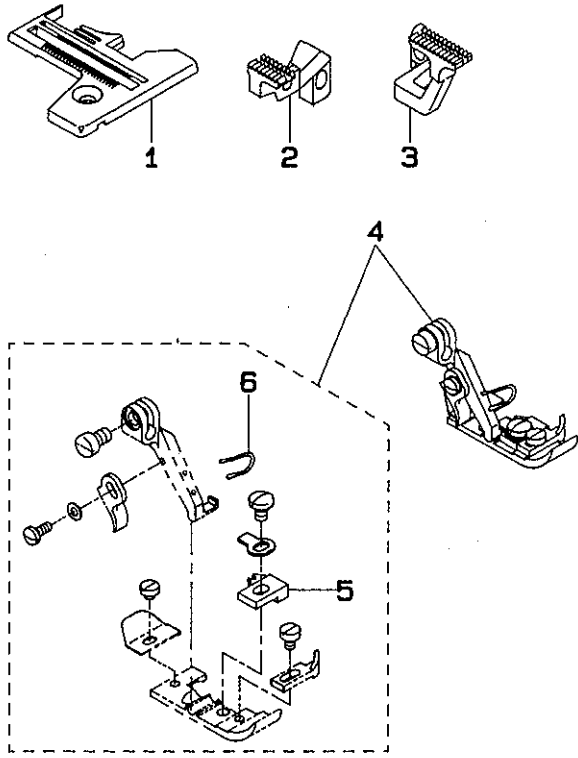

(11) SP172S800MACC

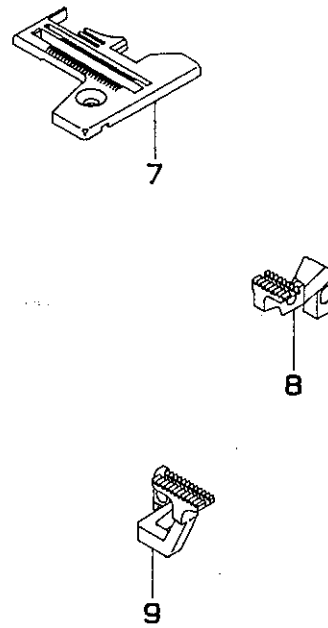

REF.NO	NOTE	PART NO.	DESCRIPTION	ヒシメイ	Qty
1		R4205-KOB-D00	THROAT PLATE	ハリタ	1
2		122-35107	MAIN FEED DOG	シュ オクリハ	1
3		122-36600	DIFFERENTIAL FEED DOG	フク オクリハ	1
4		122-30561	PRESSER FOOT ASM.	オサエケツコウ	1
5		118-74203	STITCH TONGUE	イヌハ	(1)
6		118-20701	FINGER GUARD	エビガード	(1)
7		R4200-KOD-D00	THROAT PLATE	ハリタ	1
8		122-35107	MAIN FEED DOG	シュ オクリハ	1
9		122-36600	DIFFERENTIAL FEED DOG	フク オクリハ	1

\*ALL PARTS NOT MENTIONED ABOVE ARE SAME AS THOSE OF SP172S900MADC.  
上記以外の部品は、SP172S900MADC と共通です。

(12) SP172S800MADC

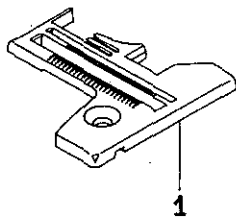

1

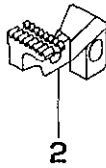

2

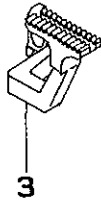

3

(13) SP172S900MACC

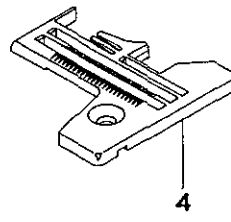

4

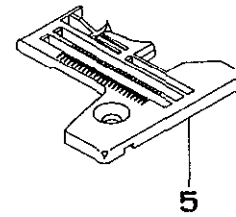

5



6

REF.NO	NOTE	PART NO.	DESCRIPTION	ヒ ン メ イ	Qty
1		R4205-KOE-D00	THROAT PLATE	ハリタ	1
2		122-35107	MAIN FEED DOG	シェ オクリハ	1
3		122-36600	DIFFERENTIAL FEED DOG	フケ オクリハ	1
4		R4305-KOD-E00	THROAT PLATE	ハリタ	1
5	#01	R4305-KOD-E0A	THROAT PLATE	ハリタ	1
6	#01	122-38200	AUXILIARY FEED DOG	ホジ ヨオクリハ	1

Note (注記) #01...P04/Q01 EXCHANGING PARTS

P04/Q01 交換部品

\*ALL PARTS NOT MENTIONED ABOVE ARE SAME AS THOSE OF SP172S900MADC.  
上記以外の部品は、SP172S900MADC と共通です。



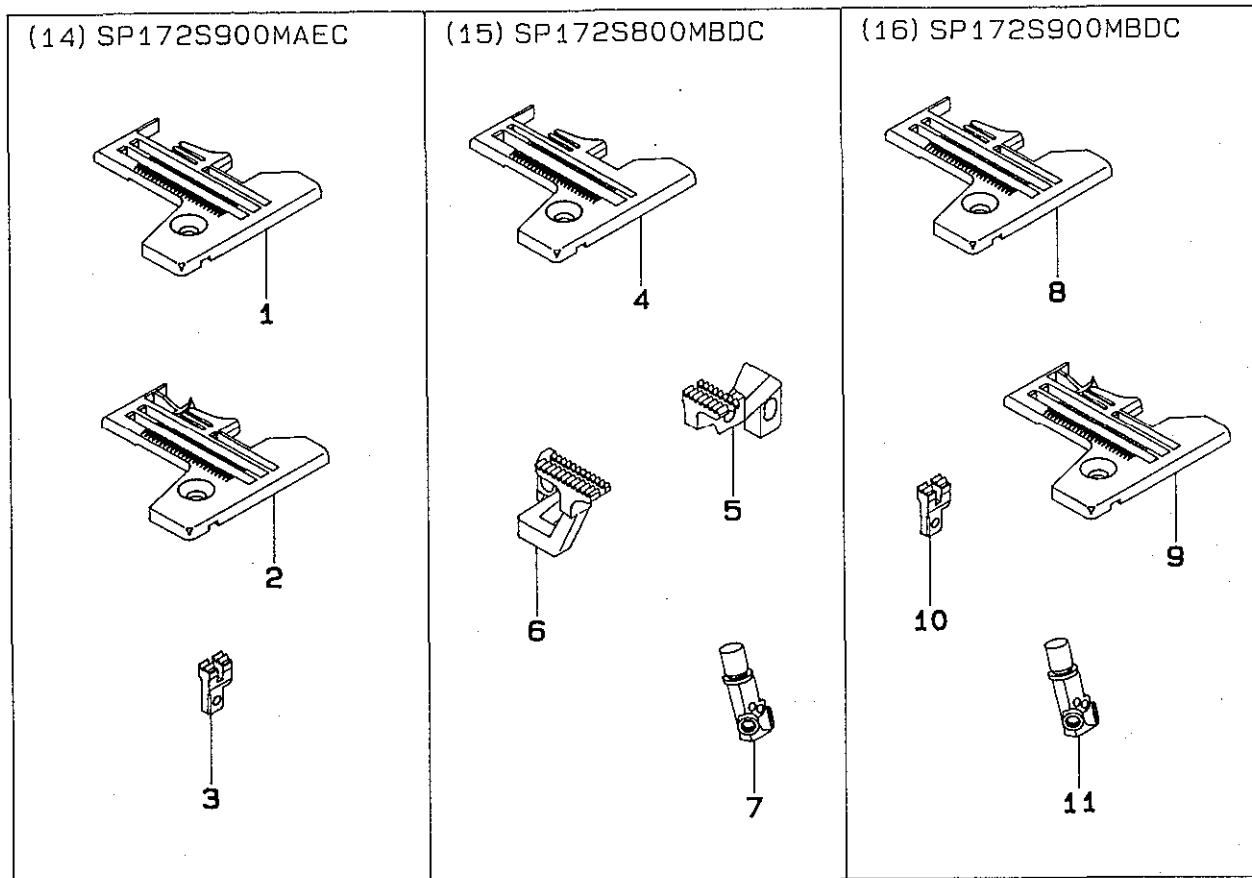

REF.NO	NOTE	PART NO.	DESCRIPTION	ヒンメイ	Qty
1		R4305-KOF-E00	THROAT PLATE	ハリイ	1
2	#01	R4305-KOF-E0A	THROAT PLATE	ハリイ	1
3	#01	122-38200	AUXILIARY FEED DOG	ホジョウクリハ	1
4		R4206-KOE-D00	THROAT PLATE	ハリイ	1
5		122-35107	MAIN FEED DOG	シュオクリハ	1
6		122-36600	DIFFERENTIAL FEED DOG	フクオクリハ	1
7		121-49209	NEEDLE CLAMP, 2-NEEDLE	ニホンハリハリトメ	1
8		R4306-KOE-E00	THROAT PLATE	ハリイ	1
9	#02	R4306-KOE-E0A	THROAT PLATE	ハリイ	1
10	#02	122-38200	AUXILIARY FEED DOG	ホジョウクリハ	1
11		121-49209	NEEDLE CLAMP, 2-NEEDLE	ニホンハリハリトメ	1

Note (注記) #01...P06/Q01 EXCHANGING PARTS  
 #02...P07/Q01 EXCHANGING PARTS

P06/Q01 交換部品  
 P07/Q01 交換部品

\*ALL PARTS NOT MENTIONED ABOVE ARE SAME AS THOSE OF SP172S900MADC.  
 上記以外の部品は、SP172S900MADC と共通です。

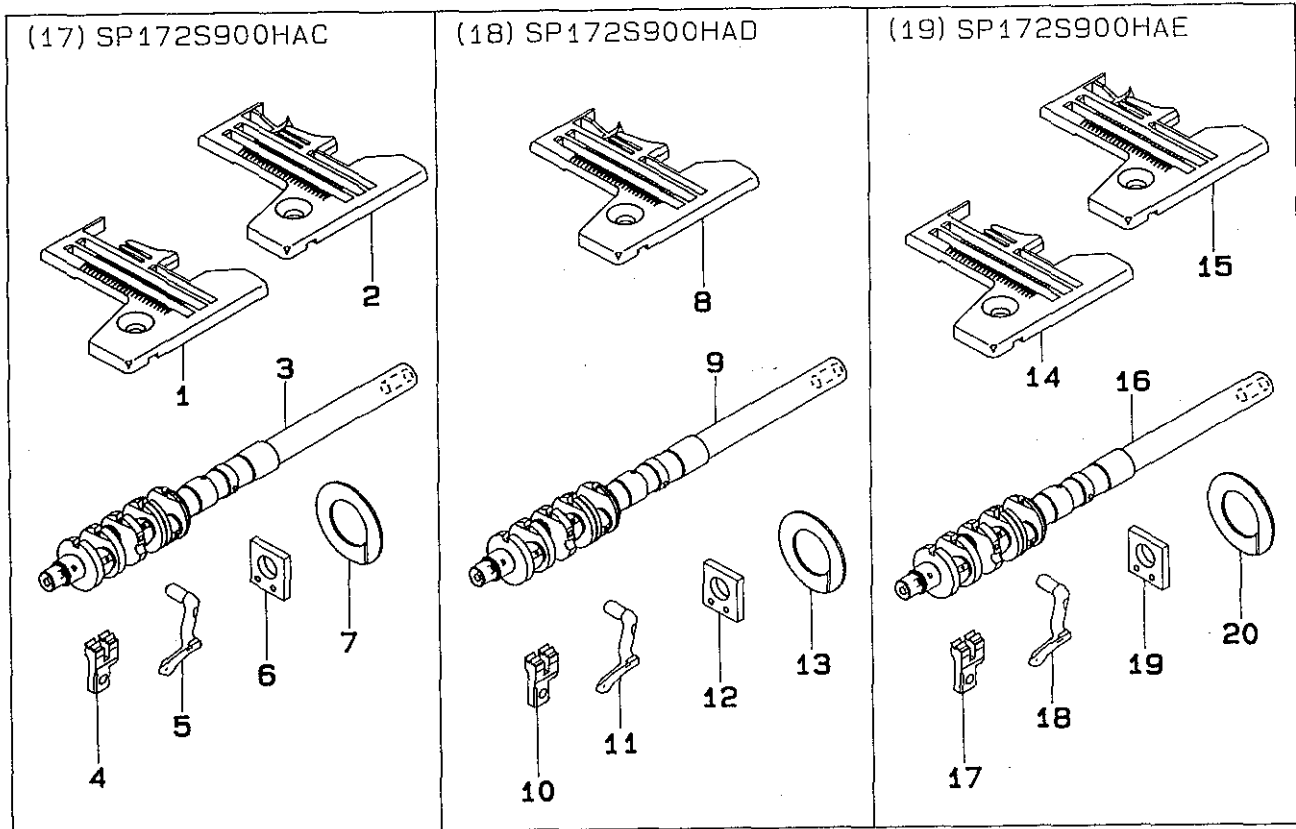

REF.NO	NOTE	PART NO.	DESCRIPTION	ヒンメイ	Qty
1		R4305-KOD-E00	THROAT PLATE	ハリイタ	1
2	#01	R4305-KOD-E0A	THROAT PLATE	ハリイタ	1
3		122-03709	MAIN SHAFT	シュジツク	1
4	#01	122-38200	AUXILIARY FEED DOG	ホジヨオクリハ	1
5		122-47102	UPPER LOOPER	ウエルハー	1
6		118-93609	GAUGE	ウワルハ カイトササエ ケーシ	1
7		121-45108	STOPPER	ルハ ロットフレツメ	2
8	#02	R4305-KOE-E0A	THROAT PLATE	ハリイタ	1
9		122-03709	MAIN SHAFT	シュジツク	1
10	#02	122-38200	AUXILIARY FEED DOG	ホジヨオクリハ	1
11		122-47102	UPPER LOOPER	ウエルハー	1
12		118-93609	GAUGE	ウワルハ カイトササエ ケーシ	1
13		121-45108	STOPPER	ルハ ロットフレツメ	2
14		R4305-KOF-E00	THROAT PLATE	ハリイタ	1
15	#03	R4305-KOF-E0A	THROAT PLATE	ハリイタ	1
16		122-03709	MAIN SHAFT	シュジツク	1
17	#03	122-38200	AUXILIARY FEED DOG	ホジヨオクリハ	1
18		122-47102	UPPER LOOPER	ウエルハー	1
19		118-93609	GAUGE	ウワルハ カイトササエ ケーシ	1
20		121-45108	STOPPER	ルハ ロットフレツメ	2

Note (注記) #01...P04/Q01 EXCHANGING PARTS      P04/Q01 交換部品  
 #02...P05/Q01 EXCHANGING PARTS      P05/Q01 交換部品  
 #03...P06/Q01 EXCHANGING PARTS      P06/Q01 交換部品  
 \*ALL PARTS NOT MENTIONED ABOVE ARE SAME AS THOSE OF SP172S900MADC.  
 上記以外の部品は、SP172S900MADC と共通です。

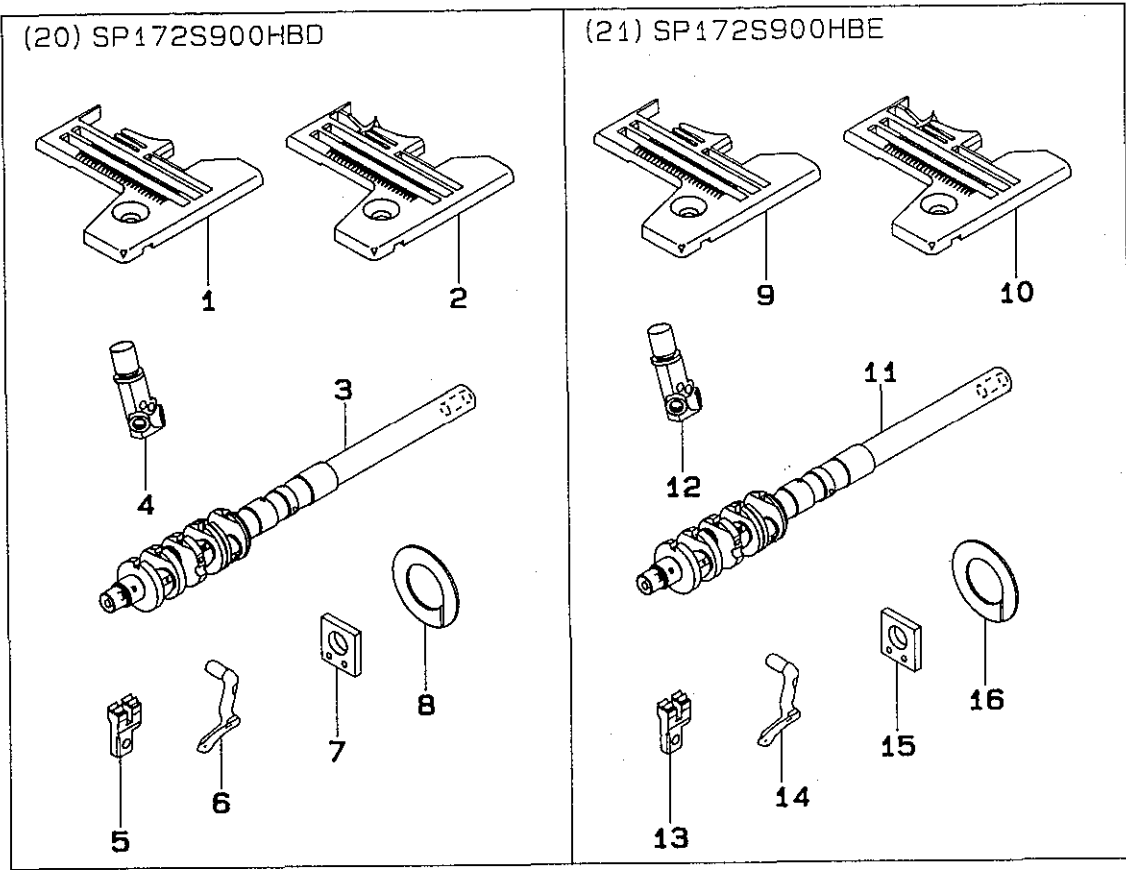

REF.NO	NOTE	PART NO.	DESCRIPTION	ヒ	ソ	メ	イ	Qty
1		R4306-KOE-E00	THROAT PLATE	ハ	リ	イ	タ	1
2	#01	R4306-KOE-E0A	THROAT PLATE	ハ	リ	イ	タ	1
3		122-03709	MAIN SHAFT	シ	ユ	ジ	ク	1
4		121-49209	NEEDLE CLAMP, 2-NEEDLE	ニ	ホ	ン	ハ	リ
5	#01	122-38200	AUXILIARY FEED DOG	ホ	シ	ョ	ウ	ク
6		122-47102	UPPER LOOPER	ウ	エ	ル	ハ	1
7		118-93609	GAUGE	ウ	ワ	ル	ハ	1
8		121-45108	STOPPER	ル	ハ	ロ	ツ	1
9		R4306-KOF-E00	THROAT PLATE	ハ	リ	イ	タ	1
10	#02	R4306-KOF-E0A	THROAT PLATE	ハ	リ	イ	タ	1
11		122-03709	MAIN SHAFT	シ	ユ	ジ	ク	1
12		121-49209	NEEDLE CLAMP, 2-NEEDLE	ニ	ホ	ン	ハ	1
13	#02	122-38200	AUXILIARY FEED DOG	ホ	シ	ョ	ウ	1
14		122-47102	UPPER LOOPER	ウ	エ	ル	ハ	1
15		118-93609	GAUGE	ウ	ワ	ル	ハ	1
16		121-45108	STOPPER	ル	ハ	ロ	ツ	2

Note (注記) #01...P07/Q01 EXCHANGING PARTS      P07/Q01 交換部品  
 #02...P08/Q01 EXCHANGING PARTS      P08/Q01 交換部品

\*ALL PARTS NOT MENTIONED ABOVE ARE SAME AS THOSE OF SP172S900MADC.  
 上記以外の部品は、SP172S900MADC と共通です。



NUMERICAL INDEX OF PARTS

索引

PART NO 品番	PAGE 頁	REF NO	PART NO 品番	PAGE 頁	REF NO	PART NO 品番	PAGE 頁	REF NO	PART NO 品番	PAGE 頁	REF NO
SS-8080410-TP	6	13	101-26803	26	9	119-57750	28	1	121-18600	10	30
SS-8080410-TP	22	31	111-11705	22	18	119-60002	27	4	121-18709	12	65
SS-8090530-TP	8	14	111-55108	27	13	119-68609	27	3	121-22107	6	28
SS-8110410-TP	2	19	111-55207	27	14	119-92161	32	6	121-22107	6	35
SS-8110410-TP	12	8	111-83803	28	24	119-92161	32	14	121-22206	6	32
SS-8110410-TP	12	10	111-83902	28	23	119-92161	33	5	121-22305	6	30
SS-8110410-TP	12	68	111-84009	28	20	119-92161	33	11	121-22354	6	26
SS-8110410-TP	12	74	111-84108	28	7	121-00202	4	13	121-22404	14	5
SS-8110410-TP	16	15	115-03703	4	29	121-00301	4	14	121-22503	14	4
SS-8110410-TP	26	23	115-10609	6	40	121-00400	4	1	121-22602	14	1
SS-8110422-TP	6	3	115-29005	12	60	121-00509	4	12	121-22800	14	41
SS-8110422-TP	22	28	115-29906	12	5	121-00608	4	3	121-22859	14	40
SS-8110520-TP	10	21	115-65504	23	17	121-00707	4	2	121-22909	14	34
SS-8110520-TP	16	21	115-65702	23	15	121-00806	4	5	121-23204	14	33
SS-8110710-SP	8	23	115-65801	23	10	121-01408	2	22	121-23808	14	19
SS-8111010-TP	12	32	115-66809	23	11	121-01507	2	10	121-23907	14	23
SS-8120410-SP	8	6	115-71403	27	8	121-01804	4	9	121-24004	14	10
SS-8120410-SP	26	47	115-71601	27	2	121-01903	4	7	121-24202	14	17
SS-8151150-SP	6	48	115-98000	23	13	121-02000	4	26	121-26108	20	47
SS-8660330-SP	23	7	118-03004	2	16	121-02505	4	17	121-26207	20	3
SS-8660530-TP	14	3	118-05207	4	21	121-03206	2	21	121-26405	20	12
SS-8660530-TP	14	63	118-06304	29	13	121-03404	2	26	121-26405	20	21
SS-8660610-TP	8	9	118-10306	4	35	121-04907	4	28	121-26405	20	30
SS-8660610-TP	12	53	118-11601	6	46	121-07611	6	47	121-26504	20	37
SS-9090410-TP	14	36	118-19109	16	37	121-07702	6	43	121-26702	20	8
SS-9090610-TP	14	9	118-19307	16	36	121-07801	6	45	121-26702	20	17
SS-9090610-TP	14	43	118-19414	16	26	121-09104	6	24	121-26702	20	26
SS-9111610-SP	23	19	118-19703	16	29	121-09153	6	23	121-26801	20	14
SS-9151210-TP	4	20	118-20701	18	18	121-09203	8	3	121-26850	20	13
SS-9151210-TP	6	31	118-20701	18	33	121-09252	8	1	121-26900	20	5
SS-9151210-TP	6	38	118-20701	30	6	121-09302	8	4	121-26959	20	4
SS-9151210-TP	8	2	118-20701	31	14	121-09401	8	5	121-27007	20	23
SS-9151210-TP	8	12	118-20701	32	8	121-09500	8	7	121-27056	20	22
SS-9151210-TP	10	23	118-20701	32	16	121-09609	8	13	121-27403	20	31
SS-9151210-TP	12	51	118-20701	33	7	121-09658	8	11	121-27502	20	32
SS-9151210-TP	14	8	118-20701	33	13	121-09906	8	17	121-27601	20	33
SS-9151210-TP	14	42	118-20701	34	6	121-09906	8	54	121-27700	20	34
SS-9151210-TP	14	54	118-23804	8	10	121-09955	8	15	121-27809	20	35
SS-9151210-TP	16	34	118-23804	10	26	121-09955	8	52	121-27957	20	36
SS-9152130-CP	26	30	118-23804	23	1	121-10102	8	18	121-28203	20	38
SS-9661230-CP	23	4	118-28050	12	7	121-10201	8	20	121-28302	20	39
SS-9681610-TP	6	50	118-31708	14	45	121-10250	8	19	121-29102	26	16
			118-31757	14	44	121-10300	8	21	121-29201	26	26
TA-0290301-HO	26	4	118-31807	14	26	121-10409	8	24	121-29250	26	17
TA-0400301-HO	26	50	118-31906	14	25	121-10607	8	26	121-29300	26	21
TA-0400301-HO	26	53	118-33407	14	22	121-10805	8	28	121-29607	26	35
TA-0620504-RO	20	40	118-33506	14	12	121-10904	8	27	121-29706	26	2
TA-0750704-RO	4	38	118-40303	26	25	121-11209	8	36	121-29805	26	41
TA-0800504-RO	4	39	118-40402	26	27	121-11308	8	38	121-29854	26	38
TA-0950806-RO	24	14	118-41707	26	22	121-11506	8	49	121-29904	26	39
TA-0951301-RO	8	43	118-41806	26	24	121-11605	8	51	121-30001	26	40
TA-1450404-RO	2	6	118-43208	26	1	121-11803	8	46	121-30100	26	32
TA-1470702-RO	4	40	118-43406	26	28	121-11902	8	48	121-30209	26	33
TA-1701107-RO	4	22	118-45807	23	14	121-12108	8	39	121-30308	26	48
TA-2050805-RO	4	19	118-45906	32	4	121-12207	8	42	121-30407	26	49
			118-45906	32	12	121-12306	8	41	121-30506	26	51
WP-0250516-SD	18	8	118-45906	33	3	121-12405	8	44	121-30605	26	52
WP-0250516-SD	18	32	118-45906	33	9	121-13601	16	23	121-30704	26	44
WP-0370316-SD	27	6	118-48405	23	18	121-13700	16	24	121-30803	26	43
WP-0371026-SD	12	29	118-56101	24	5	121-13809	16	33	121-32106	6	19
WP-0371026-SD	24	15	118-72009	18	5	121-13858	16	32	121-32155	6	18
WP-0451026-SH	12	44	118-72009	18	20	121-13908	16	30	121-32205	23	3
WP-0621016-SD	12	61	118-74203	34	5	121-14005	18	1	121-32254	23	2
WP-0651056-SH	26	31	118-74807	32	7	121-14203	16	22	121-32304	23	8
WP-0751576-SD	4	30	118-74807	32	15	121-14302	16	19	121-32403	23	12
WP-0764016-SP	6	49	118-74807	33	6	121-14450	16	20	121-32502	23	5
WP-0841600-0E	29	20	118-74807	33	12	121-14609	16	14	121-38152	24	12
WP-1102016-SC	27	10	118-93609	31	17	121-14708	16	11	121-38301	24	13
WP-1702600-SO	28	28	118-93609	37	6	121-14807	16	13	121-38400	24	11
WS-0510002-KN	28	25	118-93609	37	12	121-14906	16	17	121-45108	31	18
WS-0822010-KP	4	31	118-93609	37	19	121-15002	16	2	121-45108	37	7
WS-1002560-KR	27	11	118-93609	38	7	121-15051	16	1	121-45108	37	13
WS-1643202-KR	28	2	118-93609	38	15	121-15101	16	3	121-45108	37	20
WZ-0850302-KO	4	24	118-98103	29	6	121-15200	16	4	121-45108	38	8
WZ-0850302-KO	29	21	119-57404	28	19	121-15309	16	8	121-45108	38	16
WZ-2640310-KH	6	41	119-57503	28	8	121-18303	12	25	121-48607	8	30

NUMERICAL INDEX OF PARTS

索引

PART NO 品番	PAGE 頁	REF NO	PART NO 品番	PAGE 頁	REF NO	PART NO 品番	PAGE 頁	REF NO	PART NO 品番	PAGE 頁	REF NO
121-48706	8	33	122-14607	30	3	122-38200	31	6			
121-49209	36	7	122-14607	30	12	122-38200	31	11			
121-49209	36	11	122-14607	31	5	122-38200	35	6			
121-49209	38	4	122-14607	31	19	122-38200	36	3			
121-49209	38	12	122-14656	14	6	122-38200	36	10			
121-80154	20	1	122-14706	14	35	122-38200	37	4			
121-80253	20	2	122-14755	14	32	122-38200	37	10			
121-80352	32	5	122-14805	14	30	122-38200	37	17			
121-80352	32	13	122-14904	14	61	122-38200	38	5			
121-80550	33	4	122-15000	14	64	122-38200	38	13			
121-80550	33	10	122-15109	6	37	122-40107	14	48			
122-00200	2	1	122-15158	6	33	122-40602	14	65			
122-00309	2	2	122-15208	14	60	122-40701	22	4			
122-00408	2	3	122-15307	14	50	122-47102	14	39			
122-00507	2	5	122-15356	14	49	122-47102	31	16			
122-00655	2	23	122-15406	14	58	122-47102	37	5			
122-00804	2	20	122-15554	14	14	122-47102	37	11			
122-00903	2	18	122-15604	14	56	122-47102	37	18			
122-01109	4	34	122-15703	14	28	122-47102	38	6			
122-01208	4	33	122-18152	26	15	122-47102	38	14			
122-03600	6	11	122-19101	22	1	122-47300	14	38			
122-03709	31	15	122-19200	22	8	122-47508	32	2			
122-03709	37	3	122-19358	22	9	122-47508	32	10			
122-03709	37	9	122-19507	22	7	122-60204	4	41			
122-03709	37	16	122-19606	22	6	135-08700	14	53			
122-03709	38	3	122-19705	22	25						
122-03709	38	11	122-19804	22	3						
122-03816	6	51	122-19903	22	2						
122-03907	6	15	122-20000	22	10						
122-04004	6	2	122-20109	22	5						
122-04103	6	14	122-20208	22	12						
122-04202	6	10	122-20307	22	11						
122-06603	16	41	122-20406	30	13						
122-06702	16	38	122-20505	22	23						
122-08104	10	2	122-20604	22	29						
122-08161	10	1	122-21602	27	1						
122-08203	10	4	122-21750	27	9						
122-08302	10	11	122-21800	27	7						
122-08401	10	12	122-24606	24	2						
122-08500	10	18	122-24705	24	3						
122-08609	10	17	122-24853	24	1						
122-08708	10	19	122-25009	24	6						
122-08807	10	15	122-26155	29	8						
122-08906	10	10	122-26163	29	9						
122-09003	10	24	122-26304	29	10						
122-09052	10	22	122-26403	29	11						
122-09102	12	35	122-26502	29	12						
122-09201	12	36	122-29100	2	8						
122-09300	12	37	122-30165	18	4						
122-09409	12	48	122-30264	18	19						
122-09458	12	46	122-30462	30	4						
122-09508	12	47	122-30462	31	12						
122-09607	12	49	122-30561	34	4						
122-09706	12	43	122-32104	18	12						
122-09805	12	42	122-32104	18	21						
122-09904	12	2	122-35107	12	14						
122-09953	12	1	122-35107	34	2						
122-10001	12	3	122-35107	34	8						
122-10100	6	9	122-35107	35	2						
122-10209	12	11	122-35107	36	5						
122-10308	12	6	122-35206	12	15						
122-10407	12	26	122-35206	30	9						
122-10506	12	24	122-35206	31	3						
122-10605	12	23	122-35206	31	9						
122-10704	12	30	122-36600	12	20						
122-10803	12	31	122-36600	34	3						
122-10902	12	41	122-36600	34	9						
122-11009	12	54	122-36600	35	3						
122-11157	12	64	122-36600	36	6						
122-11306	12	69	122-36709	12	21						
122-11405	12	56	122-36709	30	10						
122-11504	12	71	122-36709	31	4						
122-11603	12	57	122-36709	31	10						
122-11702	10	28	122-38101	12	18						
122-11801	10	27	122-38200	12	19						
122-14607	14	7	122-38200	30	11						



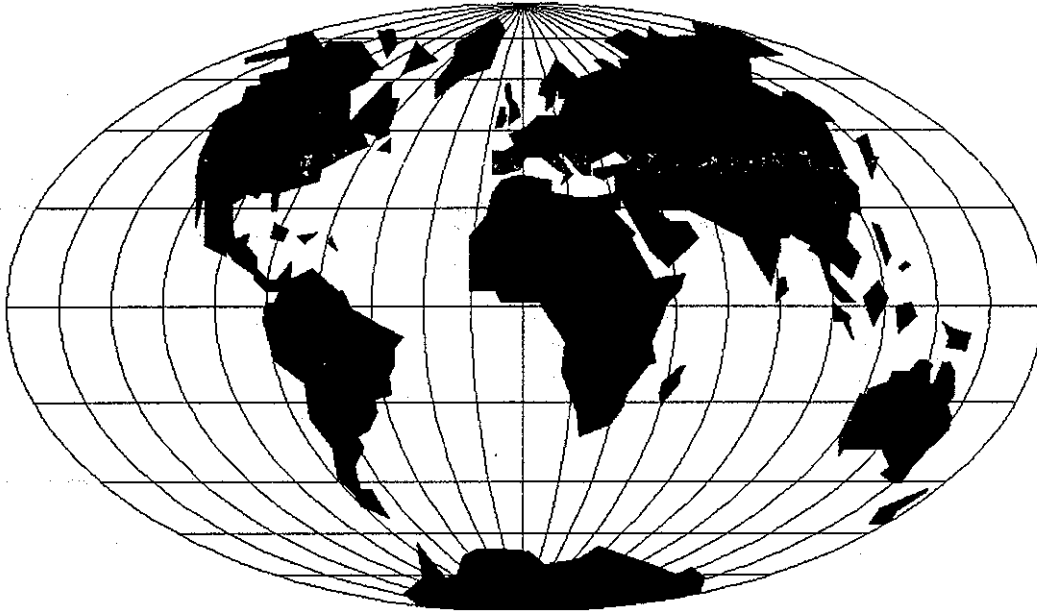

## WORLDWIDE SALES AND SERVICE

Union Special Corporation maintains sales and service facilities throughout the world. These offices will aid you in the selection of the right sewing equipment for your particular operation. Union Special Corporation representatives and service technicians are factory trained and are able to serve your needs promptly and efficiently. Whatever your location, there is a qualified representative to serve you.

---

**Corporate Office:** One Union Special Plaza  
Huntley, IL 60142  
Phone: 847•669•5101  
Fax: 847•669•1096

**European Distribution Center:** Union Special GmbH  
Raiffeisenstrasse 3  
D-71696 Möglingen, Germany  
Tel: 49•07141•247•0  
Fax: 49•7141•247•100

Brussels, Belgium  
Charlotte, N.C.  
El Paso, TX  
Hong Kong, China  
Huntley, IL  
Leicester, England  
Lille, France  
Miami, FL  
Milan, Italy  
Möglingen, Germany  
Montreal, Quebec  
Osaka, Japan  
Santa Fe Springs, CA

Other Representatives throughout  
all parts of the world.



*Union Special*  
INDUSTRIAL SEWING EQUIPMENT