

MANUAL NO.
PT9508

ILLUSTRATED PARTS LIST

STYLES

SP151H429M032
SP151H430M032
SP161S400M032
SP161S400M032C
SP161S400M040C
SP161S400M048C
SP172S400MACC
SP172S400HAC
SP172S400HBE

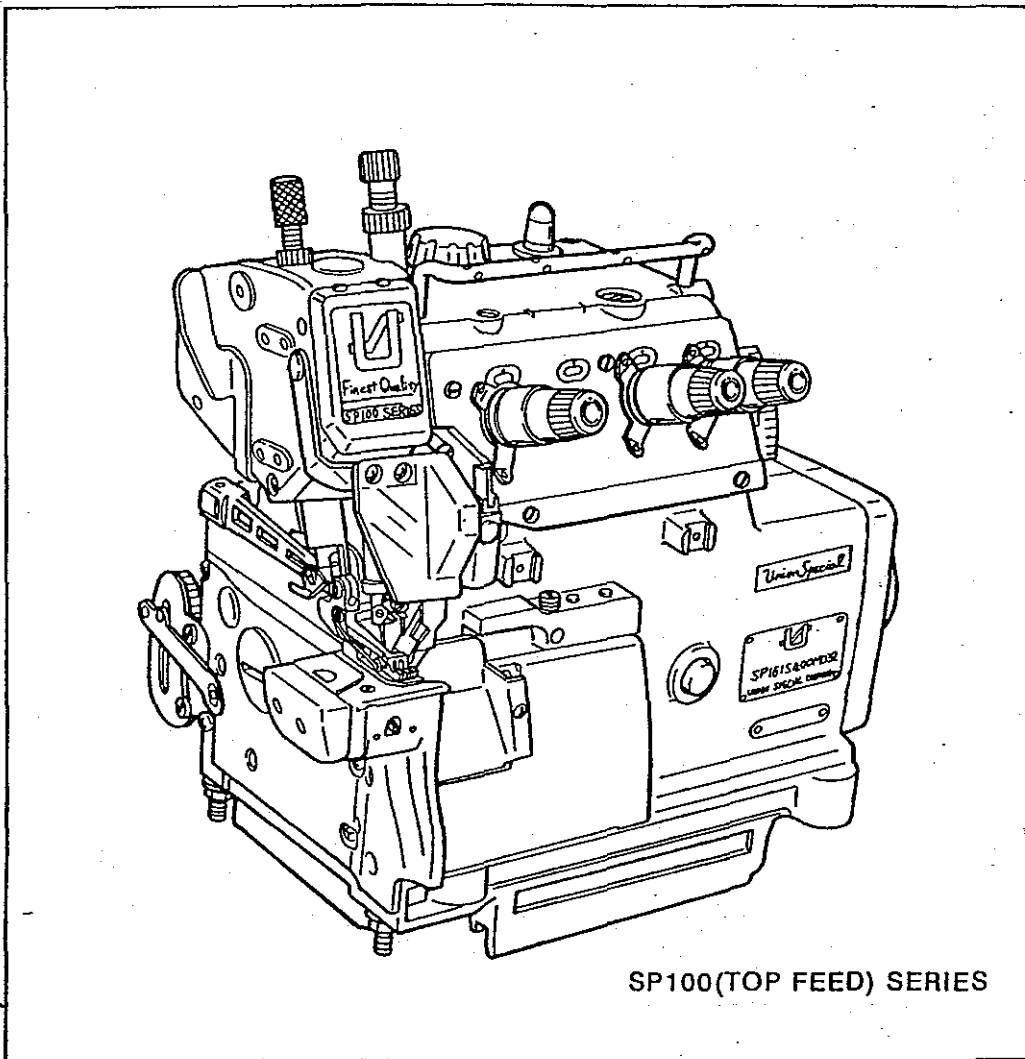

Finest Quality

Union Special
INDUSTRIAL SEWING EQUIPMENT

29189305
No.1109-00

Manual No. PT9508 Illustrated Parts List for the SP100 Top Feed Series Machines

First Edition Copyright 1995

By

Union Special Corporation Rights Reserved In All Countries

Printed in Japan April 1995

PREFACE

This parts manual has been prepared to assist you in locating individual parts or assemblies on the SP100 Top Feed Series machines. It can be used in conjunction with Union Special Adjusting manual IN9509.

It is the desire of Union Special that each machine run at its optimum performance. Parts listed in this manual are designed specifically for your machine and are manufactured with utmost precision to assure long lasting service.

This manual has been compiled on the basis of available information. Changes in design and/or improvements may lead to slight differences in the illustrations or part numbers.

Illustrations and terminology used in describing the parts used on the SP100 Top Feed Series machines will be found in the following pages.

SAFETY RULES

1. Before putting the machines described in this manual into service, carefully read the instructions. The starting of each machine is only permitted after taking notice of the instructions, and only by qualified operators.

IMPORTANT! Before putting the machine into service, also read the safety rules and instructions from the motor supplier.

2. Observe the national safety rules applied in your country.
3. It is strictly prohibited to put the sewing machines described in this instruction manual into service until it has been confirmed that the sewing units into which they will be installed are in conformance with the EC Council Directives (89/392/EEC, Annex II B).

The use of each machine is only permitted in the intended and anticipated manner. The intended and anticipated use of particular machines is described in paragraph "STYLES OF MACHINES" of this instruction manual. Other uses, going beyond the description, are not deemed as intended.

4. All safety devices must be in position when the machine is ready for work or in operation. Operation of the machine without the appertaining safety devices is prohibited.
5. Wear safety glasses.
6. When making conversions and changes to the machines, all valid safety rules must be considered. Conversions and changes are made at your own risk.
7. The warning hints in the instructions are marked with one of these symbols.



8. Before performing the following operations, be sure to disconnect the machine from the power supply by turning off the main switch or by pulling out the main plug:
 - 8.1 When threading needle(s), the looper, spreader, etc.
 - 8.2 When replacing any parts, including the needle, presser foot, throat plate, looper, spreader, feed dog, needle guard, folder, fabric guide, etc.
 - 8.3 When leaving the workplace or when the workplace is unattended.
 - 8.4 When performing maintenance work.
 - 8.5 When using clutch motors without actuation lock, wait until the motor is stopped totally.
9. Maintenance, repair and conversion work (see item 8) must be performed only by trained technicians or special skilled personnel in strict accordance with the instructions provided.
10. Any work on the electrical equipment must be performed by an electrician or under the direction and supervision of special skilled personnel.
11. Work on parts and equipment when electrical power is supplied is not permitted. Permissible exceptions are described in the applicable sections of standard sheet DIN VDE 0105.
12. Before performing maintenance and repair work on the pneumatic equipment, the machine has to be disconnected from the compressed air supply. If residual air pressure remains after disconnecting from the compressed air supply (i.e. pneumatic equipment with air tank), the pressure has to be removed by bleeding.

Section 1 to 19 (page 1 to 34) of this parts list cover the machine of model No.
SP161S400M032 and SP172S400MACC.

For subclass machine, refer to Section 20 Subclasses (page 35).

このパーツリストの1～19項目は標準機種 (SP161S400M032, SP172S400MACC)を示しています。
その他サブクラスは20項目を御覧ください。

CONTENTS

目次

1. FRAME COMPONENTS(1)	1
フレーム関係 (1)	
2. FRAME COMPONENTS(2)	3
フレーム関係 (2)	
3. CRANKSHAFT COMPONENTS	5
主軸関係	
4. NEEDLE DRIVING SHAFT COMPONENTS	7
針駆動軸関係	
5. FEED MECHANISM COMPONENTS(1)	9
送り関係(1)	
6. FEED MECHANISM COMPONENTS(2)	11
送り関係(2)	
7. UPPER FEED MECHANISM COMPONENTS(1)	13
上送り関係(1)	
8. UPPER FEED MECHANISM COMPONENTS(2)	15
上送り関係(2)	
9. UPPER & LOWER LOOPER COMPONENTS	17
上ルーバ、下ルーバ関係	
10. PRESSER FOOT COMPONENTS(1)	19
押え関係 (1)	
11. PRESSER FOOT COMPONENTS(2)	21
押え関係 (2)	
12. THREAD TENSION COMPONENTS	23
糸調子関係	
13. LOWER KNIFE COMPONENTS	25
下メス関係	
14. UPPER KNIFE COMPONENTS	27
上メス関係	
15. NEEDLE COOLING MECHANISM COMPONENTS	28
針冷却装置関係	
16. LUBRICATION MECHANISM COMPONENTS	29
給油装置関係	
17. THREAD STAND COMPONENTS	31
糸立装置関係	

18. SEMI-SUNKEN TYPE TABLE COMPONENTS	33
卓上式テーブル関係	
19. SPECIAL ORDER PARTS COMPONENTS	34
特別注文部品関係	
20. SUBCLASSES	
サブクラス	
(1) SP151H429M032,SP151H430M032	35
(2) SP161S400M032C	36
(3) SP161S400M040C	36
(4) SP161S400M048C	36
(5) SP172S400HAC	37
(6) SP172S400HBE	37
NUMERICAL INDEX OF PARTS	38
索引	

1. FRAME COMPONENTS(1)

フレーム関係 (1)

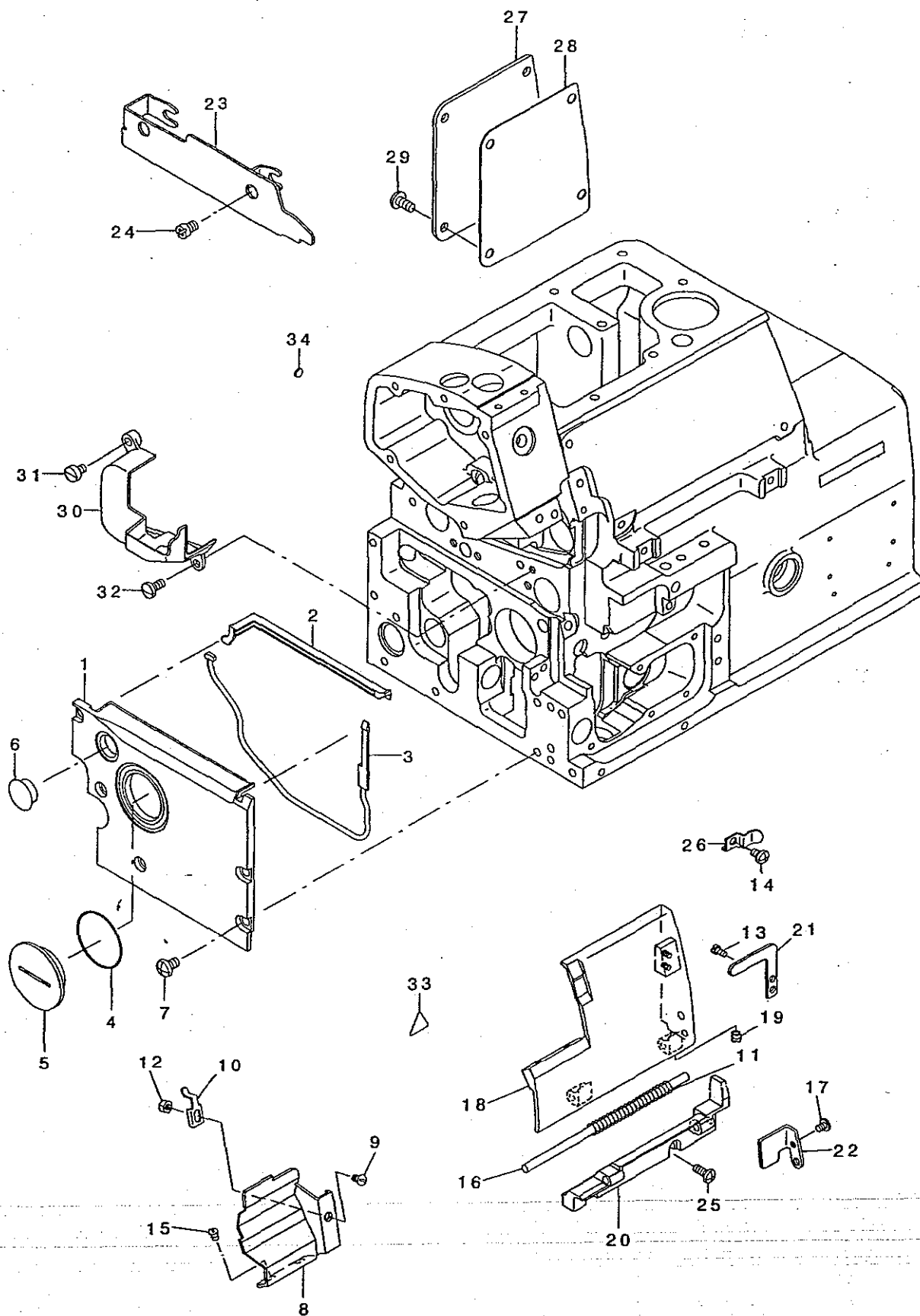

REF. NO	NOTE	PART NO.	DESCRIPTION	キ ャ ン ン ン	Qty
1		122-00200	FEED MECHAISM COVER	オクリフタ	1
2		122-00309	GASKET A	オクリフタハツキンA	1
3		122-00408	GASKET B	オクリフタハツキン B	1
4		RO-3152001-00	RUBBER RING	Oリング	1
5		122-00507	COVER	オクリ チョウヒツアナ フタ	1
6		TA-1450404-R0	RUBBER PLUG D=14.5 L=4	トメピン D=14.5 L=4	1
7		SM-4050855-SP	SCREW M5 L=8	ナハネツ M5 L=8	5
8		122-29100	CHIP GUARD COVER	ヌノクス カハ-	1
9		SS-2090520-SL	SCREW 9/64-40 L=5	マルヒラネツ 9/64-40 L=5	1
10		121-01515	CLOTH WASTE COVER STOPPER	ヌノクス カハ- ストップハ-	1
11		B1140-716-000	SPRING	ルハカハ- ハネ	1
12		NS-6090310-SN	NUT 9/64-40	ロツカクナツト 9/64-40	1
13		SS-7090530-SP	SCREW 9/64-40 L= 4.5	マルヒラネツ 9/64-40 L=4.5	1
14		SM-4040655-SP	SCREW	ナハネツ M4 L=6	1
15		SS-3090610-SP	SCREW 9/64-40 L=6	マルネツ 9/64-40 L=6	2
16		118-03004	LOOPER COVER HINGE PIN	ルハカハ- ヒツツク	1
17		SS-7090610-SP	SCREW 9/64-40 L=6	マルヒラネツ 9/64-40 L=6	1
18		122-00903	LOOPER COVER	ルハカハ-	1
19		SS-8110410-TP	SCREW 11/64-40 L= 3.5	トメネツ 11/64-40 L=3.5	1
20		122-00804	LOOPER COVER BRACKET	ルハカハ- ウケタ イ	1
21		121-03206	LOOPER COVER PRESSER PLATE	ルハカハ- オサエ イタ	1
22		121-01408	LOOPER COVER GUIDE PRATE	ルハカハ- ガイト ハン	1
23		122-90151	CROSS COVER ASM.	ヨコカハ- クミ	1
24		SS-4120615-SP	SCREW 3/16-28 L=6	ナハネツ 3/16-28 L=6	2
25		SM-4041055-SP	SCREW M4 L=10	ナハネツ M4 L=10	2
26		121-03404	LOOPER COVER PRESSER SPRING	ルハカハ- オサエ ハネ	1
27		123-00109	REAR PLATE	ハイメンフタ	1
28		123-00208	PLANE COVER PACKING	ハイメンフタハツキン	1
29		SM-4051055-SP	SCREW	ナハネツ	4
30		123-00505	UPPER FEED COVER	ウリアクリカハ-	1
31		SS-6110610-TP	SCREW 11/64-40 L=6	ヒラネツ 11/64-40 L=6	1
32		SS-7110910-SP	SCREW 11/64-40 L=8.5	マルヒラネツ 11/64-40 L=8.5	1
33	#01	CM-3002000-01	ATTENTION SEAL	ユビクガ チュウイシ-ル(16)	1
34		100-04109	GROUND MARK	ク ラント マーク	1
		NOTE (注記)	#01....FOR EUROPE	ヨーロッパ向け	

2. FRAME COMPONENTS(2)

フレーム関係 (2)

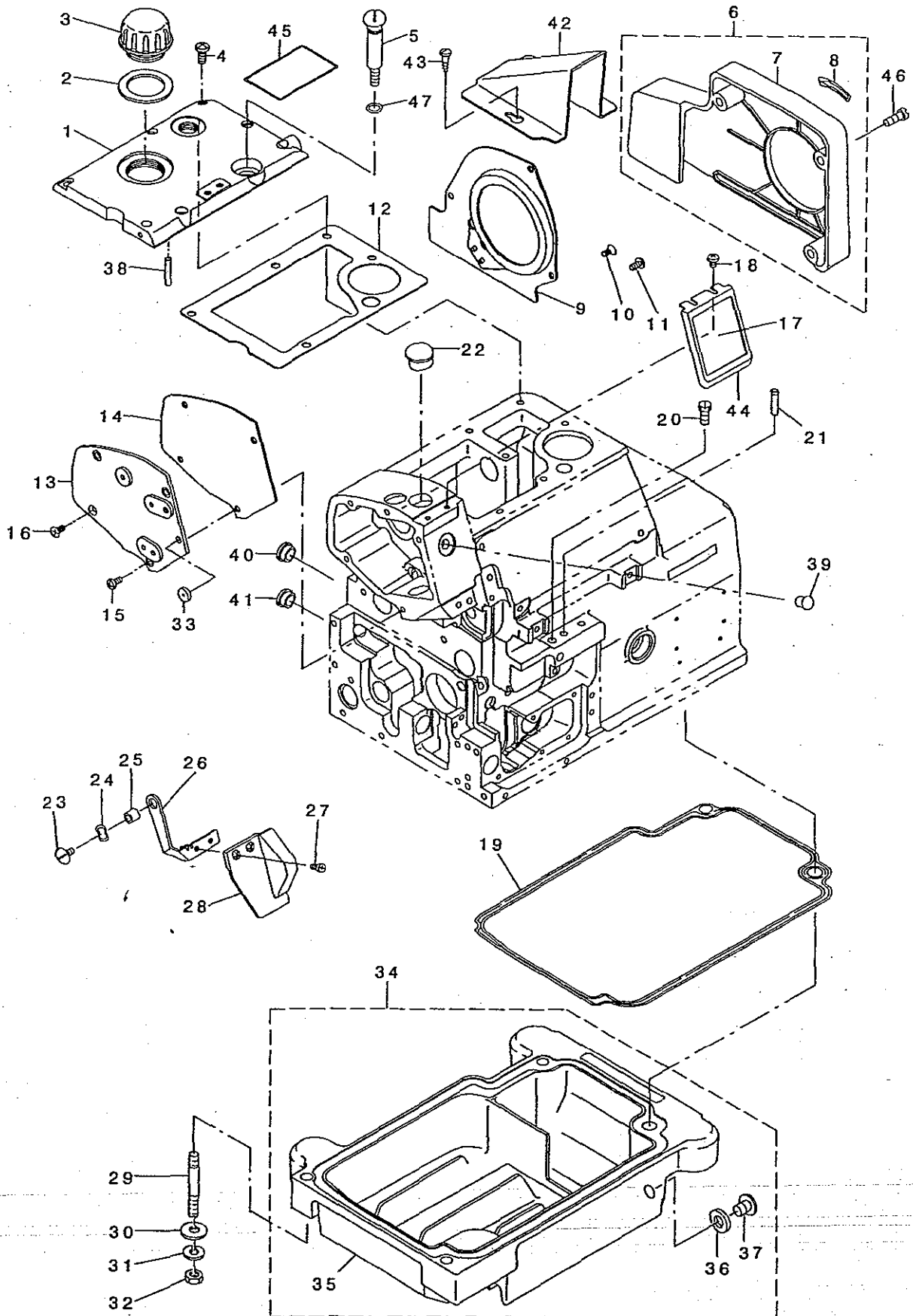

REF. NO	NOTE	PART NO.	DESCRIPTION	ヒョウメイ	Qty
1		121-00418	UPPER COVER	ウエカハ	1
2		115-00808	GASKET	チュウコナ ハ ツキン	1
3		121-00608	OIL CAP	チュウコナ フタ	1
4		SM-4051255-SP	SCREW	ナハ ネジ	5
5		121-00806	OIL DRAIN SCREW	フィルタ-ツツ ハイコウネジ	1
6		121-01960	BELT COVER ASM. A	ハ ルトカハ -クミ A	1
7		121-01903	BELT COVER	ハ ルトカハ -	(1)
8		CM-5002000-01	ROTATING DIRECTION LABEL	カイトンネウコウラハ ル	(1)
9		121-01804	COOLING FAN PLATE	レイキヤクファン イタ	1
10		SM-1040801-SC	SCREW M4X0.7 L=8	サラコネジ M4X0.7 L=8	1
11		SM-4040855-SP	SCREW	ナハ ネジ	2
12		121-00517	UPPER COVER GASKET	ウエカハ -ハ ツキン	1
13		122-50205	SIDE COVER	ソクメンカハ -	1
14		121-00301	SIDE COVER GASKET	ソクメンカハ -ハ ツキン	1
15		SM-4040855-SP	SCREW	ナハ ネジ	3
16		SM-1040801-SC	SCREW M4X0.7 L=8	サラコネジ M4X0.7 L=8	1
17		122-60204	BRAND LABEL	ブ ラント ラハ ル	1
18		SM-4040601-SC	SCREW M4X0.7 L=6	ナハ コネジ M4X0.7 L=6	2
19		122-01208	OIL RESERVOIR GASKET	アア ラダ マリ ハ ツキン	1
20		SS-9151210-TP	SCREW 15/64-28 L=11.8	ロツカクネジ 15/64-28	1
21		118-05207	THREAD GUIDE, LARGE	イトミチ ダイ	2
22		TA-1701107-RO	RUBBER PLUG	トメセン	1
23		SS-5110710-SP	SCREW 11/64-40 L=7	トラスネジ 11/64-40 L=7	1
24		WZ-0850302-KO	WAVED WASHER 8.5X12.5X0.3	ナミカ タサ ガネ 8.5X12.5X0.3	1
25		B3013-141-HOA	WASHER	リタロツト オサエガネ サガネ	1
26		121-02000	SAFETY PLATE BRACKET	メネコ カハ -ダイ	1
27		SS-7090611-SL	SCREW 9/64-40 L=6.1	マルヒラネジ 9/64-40 L=6.1	2
28		121-04907	SAFETY PLATE	メネコ カハ -	1
29		115-03703	SCREW STUD	シチュ-ホ ルト	4
30		WP-0751576-SD	WASHER 7.5X19X1.5	ヒラサガネ 7.5X19X1.5	4
31		WS-0822010-KP	SPRING WASHER 8.2X15X2	ハネサガネ 8.2X15X2	4
32		NS-6680410-SP	NUT 9/32-28	ロツカクナツト 9/32-28	4
33		122-58000	BUSH	メネコ カハ -フ ツシュ	1
34		122-90458	OIL BASIN ASM.	アア ラダ マリ (クミ)	1
35		122-90409	OIL BASIN	アア ラダ マリ	(1)
36		RO-0742401-00	RUBBER RING	オリング	(1)
37		SM-0081001-SD	SCREW	トラスネジ M8 L=10	(1)
38		PS-0300132-KH	SPRING PIN 3X13	スプリング ピン	1
39		TA-0750704-RO	RUBBER PLUG	トメセン	1
40		TA-0800504-RO	PLUG D=8 L=4.5	トメセン D=8X4.5	1
41		TA-1470702-RO	RUBBER PLUG	トメセン	1
42	#01	121-05201	BELT COVER	ハ ルトカハ -(B)	1
43	#01	SK-3412000-SC	WOOD SCREW D=4.1 L=20	マルモクネジ D=4.1 L=20	2
44		121-02513	BRAND BASE	ブ ラント ハ -ス	1
45	#02	CM-3002001-A1	SAFETY LABEL(SMALL)	アンゼンラハ ル 3(ショウ)	1
46		SS-4151215-SP	SCREW 15/64-28 L=12	ナハ ネジ 15/64-28 L=12	3
47		RO-0781901-00	RUBBER RING	オリング	1
		NOTE (注記)	#01.... FOR EUROPE #02.... EXCEPT EUROPE	ヨーロッパ 向け ヨーロッパ 向けを除く	

3. CRANKSHAFT COMPONENTS

主軸関係

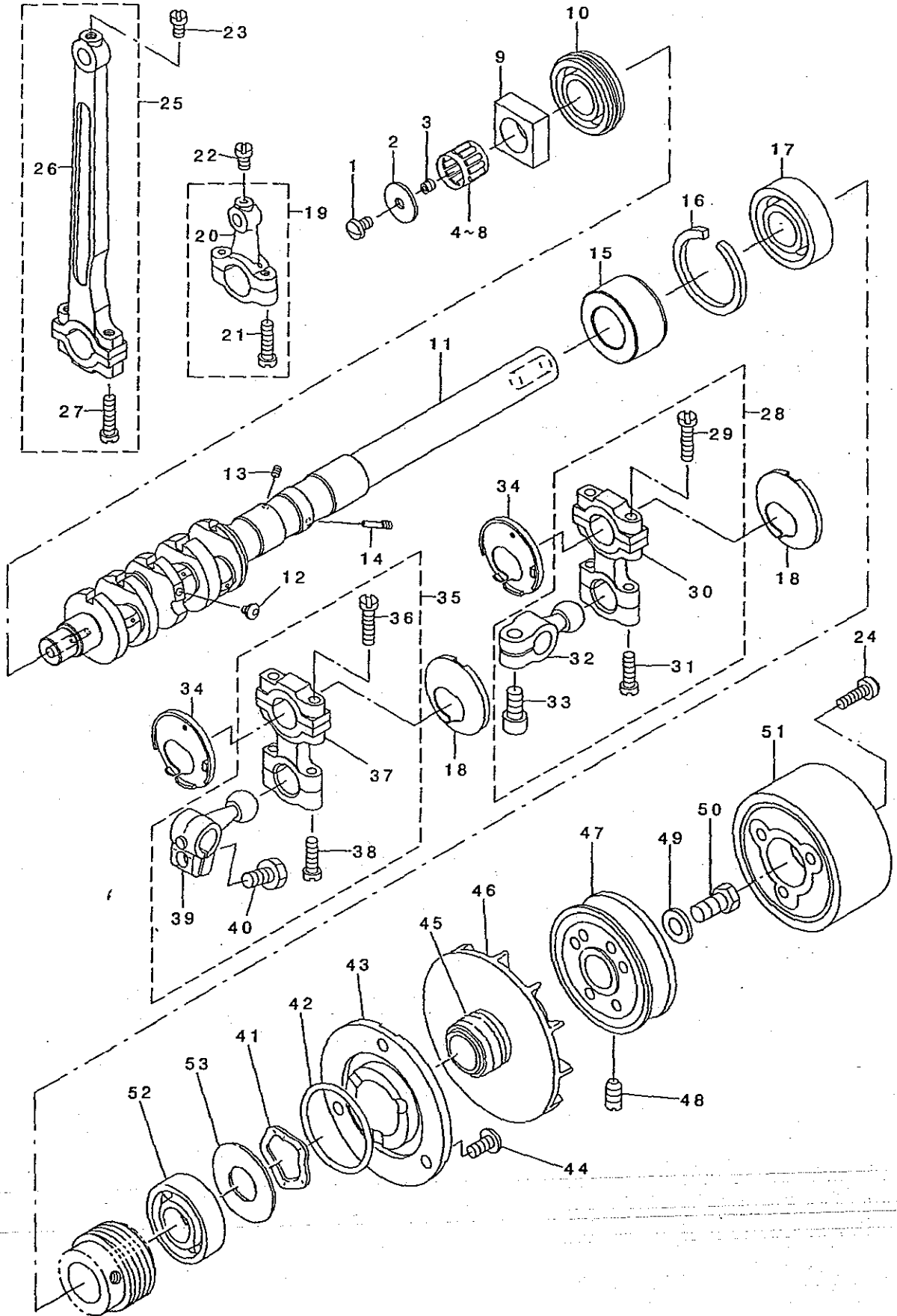

REF. NO.	NOTE	PART NO.	DESCRIPTION	ヒソメイ	Qty
1		SS-5110740-TP	SCREW 11/64-40 L= 6.5	トラスネジ 11/64-40 L=6.5	1
2		122-04004	THRUST HOLDER	カクゴ マ スラストウケ	1
3		SS-8110422-TP	SCREW 11/64-40 L=4	トメネジ 11/64-40 L=4	1
4	#01	SB-3120003-0A	BEARING	コロガ リジ クウケ	1
5	#01	SB-3120003-0B	BEARING	コロガ リジ クウケ	1
6	#01	SB-3120003-0C	BEARING	コロガ リジ クウケ	1
7	#01	SB-3120003-0D	BEARING	コロガ リジ クウケ	1
8	#01	SB-3120003-0E	BEARING	コロガ リジ クウケ	1
9		122-10100	SLIDE BLOCK	シ ヨウケ オクリ カクゴ マ	1
10		122-04202	BALL BEARING D	シュジ ク ホ -ル ハ アリソク D	1
11		122-92009	CRANKSHAFT	シュジ ク	1
12		SS-5080212-TP	SCREW 1/8-44 L=2	ハ イント ネジ	5
13		SS-8080410-TP	SCREW 1/8-44 L=3.5	トメネジ 1/8-44 L=3.5	1
14		122-04103	OIL ADJUSTING SCREW A	ユリヨウ チヨウセツネジ A	1
15		122-03907	CRANK SHAFT BUSHING C	Cメタル	1
16		B1212-704-000	BEARING RETAINER	ホ -ルハ アリソク トメテ	1
17		B1211-804-000	BALL BEARING B	シュジ ク ホ -ルハ アリソク B	1
18		121-24509	STOPPER (R)	ル-ハ -ロツト フレト メ ミキ	2
19		121-32155	KNIFE DRIVING ROD ASM.	ウエ メスロツト クミ	1
20		121-32106	KNIFE DRIVING ROD	ウエ メスロツト	(1)
21		SS-7111810-TP	SCREW 11/64-40 L=18	マルヒラネジ 11/64-40 L=18	(2)
22		SS-7110840-SP	SCREW 11/64-40 L=7.8	マルヒラネジ 11/64-40 L=7.8	1
23		SS-7110840-SP	SCREW 11/64-40 L=7.8	マルヒラネジ 11/64-40 L=7.8	1
24		SS-7111410-SP	SCREW 11/64-40 L=14	マルヒラネジ 11/64-40 L=14	3
25		121-09153	CONNECTING ROD ASM.	ハリクト ウ ロツト クミ	1
26		121-09104	CONNECTING ROD	ハリクト ウ ロツト	(1)
27		SS-7111810-TP	SCREW 11/64-40 L=18	マルヒラネジ 11/64-40 L=18	(2)
28		121-22362	UPPER LOOPER ROD ASM.	ウツル-ハ -タマウテ (クミ)	1
29		SS-7111810-TP	SCREW 11/64-40 L=18	マルヒラネジ 11/64-40 L=18	(2)
30		121-22107	LOOPER DRIVING ROD	ル-ハ -ロツト	(1)
31		SS-7111410-TP	SCREW 11/64-40 L=14	マルヒラネジ 11/64-40 L=14	(2)
32		121-22313	UPPER LOOPER ARM	ウツル-ハ -タマウテ	(1)
33		SM-6061202-TP	SCREW M6 L=12	ロツカクアホ ホト M6 L=12	(1)
34		121-24400	STOPPER (L)	ル-ハ -ロツト フレト メ ヒダ リ	2
35		122-15158	LOWER LOOPER ROD ASM., A	シタル-ハ -タマウテ クミ, A	1
36		SS-7111810-TP	SCREW 11/64-40 L=18	マルヒラネジ 11/64-40 L=18	(2)
37		121-22107	LOOPER DRIVING ROD	ル-ハ -ロツト	(1)
38		SS-7111410-TP	SCREW 11/64-40 L=14	マルヒラネジ 11/64-40 L=14	(2)
39		122-15109	LOWER LOOPER ARM A	シタ ル-ハ - タマウテ	(1)
40		SS-9151210-TP	SCREW 15/64-28 L=11.8	ロツカクホ ホト 15/64-28	(1)
41		WZ-2640310-KH	WAVED WASHER 26.4X33.9X3.5	ナミカ タサ ガ ネ 26.4X33.9X3.5	1
42		RO-3473501-00	RUBBER RING	Oソソク	1
43		121-07702	THRUST HOLDER	スラストウケ	1
44		SM-4051055-SP	SCREW	ナハ ネジ	3
45		121-07801	OIL SHIELD	シュジ クアア ラキリ	1
46		118-11619	COOLING FAN	レイキヤクファン	1
47		121-07611	FLYWHEEL A	ハズ ミグ ルマ(A)	1
48		SS-8151150-SP	SCREW 15/64-28 L=10.5	トメネジ 15/64-28 L=10.5	2
49		WP-0764016-SP	WASHER	ヒラサ ガ ネ 76X20X4	1
50		SS-9681610-TP	SCREW 9/32-28 L=16	ロツカクホ ホト 9/32-28 L=16	1
51		122-03816	FLYWHEEL C	ハズ ミグ ルマ(C)	1
52		B1211-804-000	BALL BEARING B	シュジ ク ホ -ルハ アリソク B	1
53		115-10609	WASHER	ハ アリソク ウケイタ	1
		NOTE (注記)	#01...SELECTIVE PART	選択部品	

4. NEEDLE DRIVING SHAFT COMPONENTS

針驅動軸關係

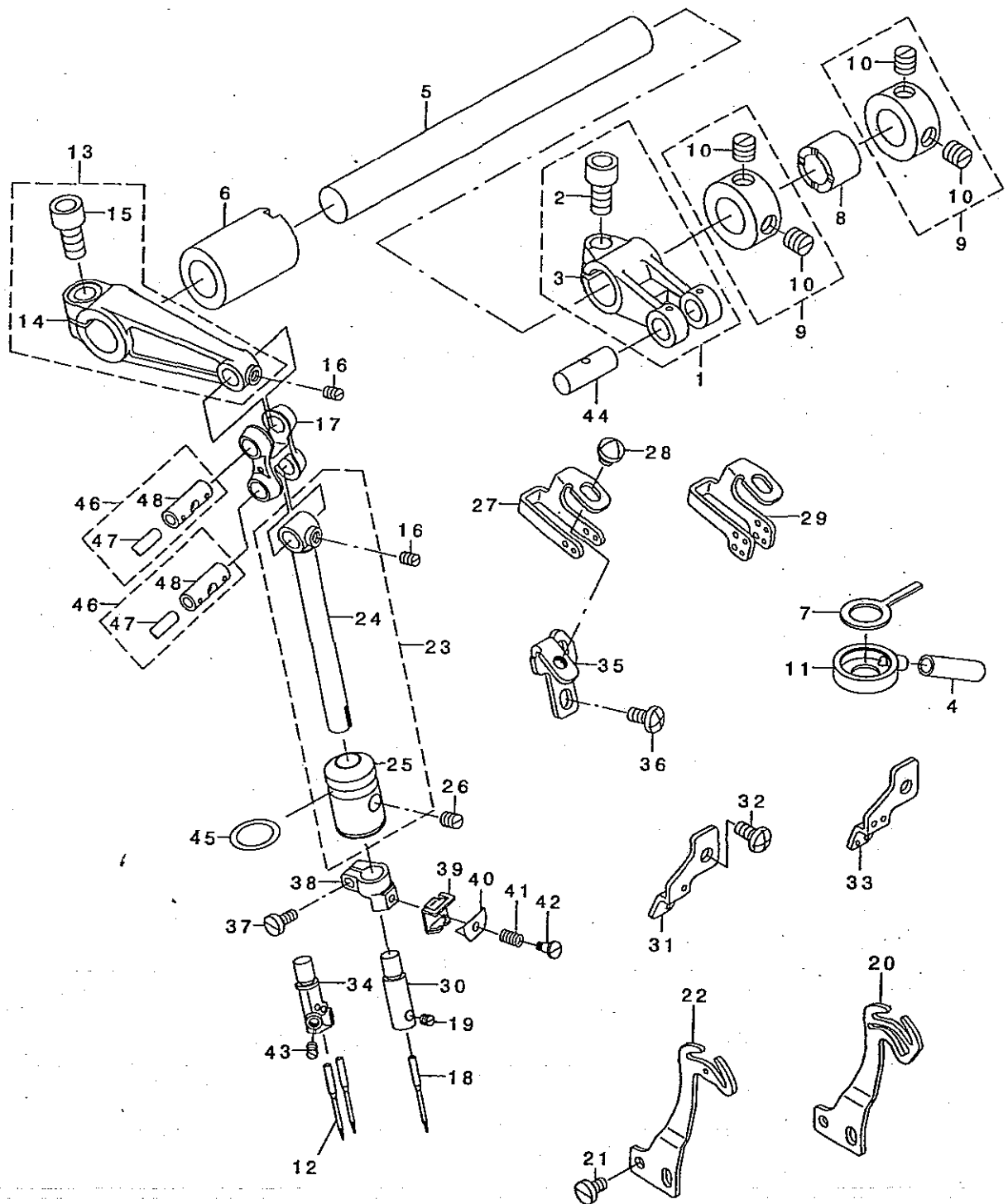

REF. NO	NOTE	PART NO.	DESCRIPTION	ヒョウメイ	Qty
1		121-09260	FEED FORKED CRANK ASM.	ハリクトウフタマタクレンク(クミ)	1
2		SM-6061202-TP	SCREW M6 L=12	ロツカクアナホノルト M6 L=12	(1)
3		121-09211	NEEDLE DRIVING FORKED CRANK	ハリクトウフタマタクレンク	(1)
4		BT-0600402-EA	OIL TUBE	チューブ	0.02
5		121-09302	NEEDLE DRIVING SHAFT	ハリクトウツク	1
6		122-52805	BUSHING, REAR	ハリクトウツククマエメタル	1
7		121-12306	FELT A	ハリカンリユウフェルト A	1
8		121-09500	BUSHING, REAR	ハリクトウツクウシロメタル	1
9		CS-1201010-SH	THRUST COLLAR ASM. D=12 W=10	スラストウケ D=12 W=10 クミ	2
10		SS-8660610-TP	SCREW 1/4-40 L=6	トメネジ 1/4-40 L=6	(4)
11		121-12207	COVER	ハリカンリユウカハ	1
12	#03	MC-0336007-50	NEEDLE B-27 NM75	ハリ B-27 75	2
13		121-09666	NEEDLE DRIVING ARM ASM.	ハリクトウウウデ(クミ)	1
14		121-09617	NEEDLE DRIVING ARM	ハリクトウウウデ	(1)
15		SM-6061202-TP	SCREW M6 L=12	ロツカクアナホノルト M6 L=12	(1)
16		SS-8090530-TP	SCREW 9/64-40 L= 5.0	トメネジ 9/64-40 L=5	2
17		122-52904	NEEDLE DRIVING LINK	ハリクトウウリツク	1
18	#02	MC-0336007-50	NEEDLE B-27 NM75	ハリ B-27 75	1
19	#02	SS-8080310-TP	SCREW 1/8-44 L=2.8	トメネジ 1/8-44 L=2.8	1
20	#03	123-04101	TAKE-UP LEVER, 2-NEEDLE	ニホソハリハリイトテンビツ	1
21		SS-6090670-TP	SCREW 9/64-40 L=6	ヒラネジ 9/64-40 L=6	2
22	#02	123-04002	NEEDLE THREAD BALANCE	ハリイトテンビツ	1
23		122-53050	NEEDLE HOLDER ASM.	ハリホウクミ	1
24		121-10219	NEEDLE HOLDER	ハリホウ	(1)
25		122-53100	NEEDLE HOLDER BUSHING	ハリホウメタル	(1)
26		SS-8110710-SP	SCREW	トメネジ	1
27	#02	121-11209	NEEDLE THREAD GUIDE	ハリイトアンナイ	1
28		SS-4110515-SP	SCREW 11/64-40 L=5	ナベネジ 11/64-40 L=5	1
29	#03	121-11308	THREAD GUIDE, 2-NEEDLE	ニホソハリハリイトアンナイ	1
30	#02	121-48607	NEEDLE CLAMP	1ホソハリハリトメ	1
31	#02	121-11803	TAKE-UP LEVER GUIDE	ハリイトテンビツカイト	1
32		SM-4040855-SP	SCREW	ナベネジ	1
33	#03	121-11902	TAKE-UP LEVER GUIDE, 2-NEEDLE	ニホソハリハリイトテンビツカイト	1
34	#03	121-48706	NEEDLE CLAMP, 2-NEEDLE	ニホソハリハリトメ	1
35		121-12108	NEEDLE THREAD GUIDE STAND	ハリイトアンナイタ	1
36		SM-4040855-SP	SCREW	ナベネジ	2
37		SS-6080720-SP	SCREW	ヒラネジ 1/8-44 L=7	1
38		122-53209	NEEDLE CLAMP HOLDER	ハリトメタキ	1
39		121-10607	NEEDLE THREAD PRESSER GUIDE, A	ハリトオサエイトアンナイ A	1
40		121-10904	NEEDLE THREAD PRESSER PLATE A	ハリトオサエイタ A	1
41		121-10805	NEEDLE THREAD PRESSER SPRING	ハリトオサエハネ	1
42		SD-0280401-SL	HINGE SCREW D=2.8 H=4	ダツネジ D=2.8 H=4	1
43	#03	SS-8080310-TP	SCREW 1/8-44 L=2.8	トメネジ 1/8-44 L=2.8	2
44	#01	118-23804	CRANK PIN C	オクリフタマタ クレンクピン C	1
45		RO-1082401-00	RUBBER RING	Oリング	1
46	#01	121-09955	LINK PIN C ASM.	ハリクトウウリツクピンC(クミ)	2
47		CQ-2520000-00	OIL WICK	ユツ	(0.07)
48		121-09906	LINK PIN C	ハリクトウウリツクピンC	(2)

NOTE (注記) #01....SELECTING PART FOR FIT TOLERANCE 選択かん合部品
#02....FOR SP161S400M032 SP161S400M032用
#03....FOR SP172S400MACC SP172S400MACC用

5. FEED MECHANISM COMPONENTS(1)

送り関係(1)

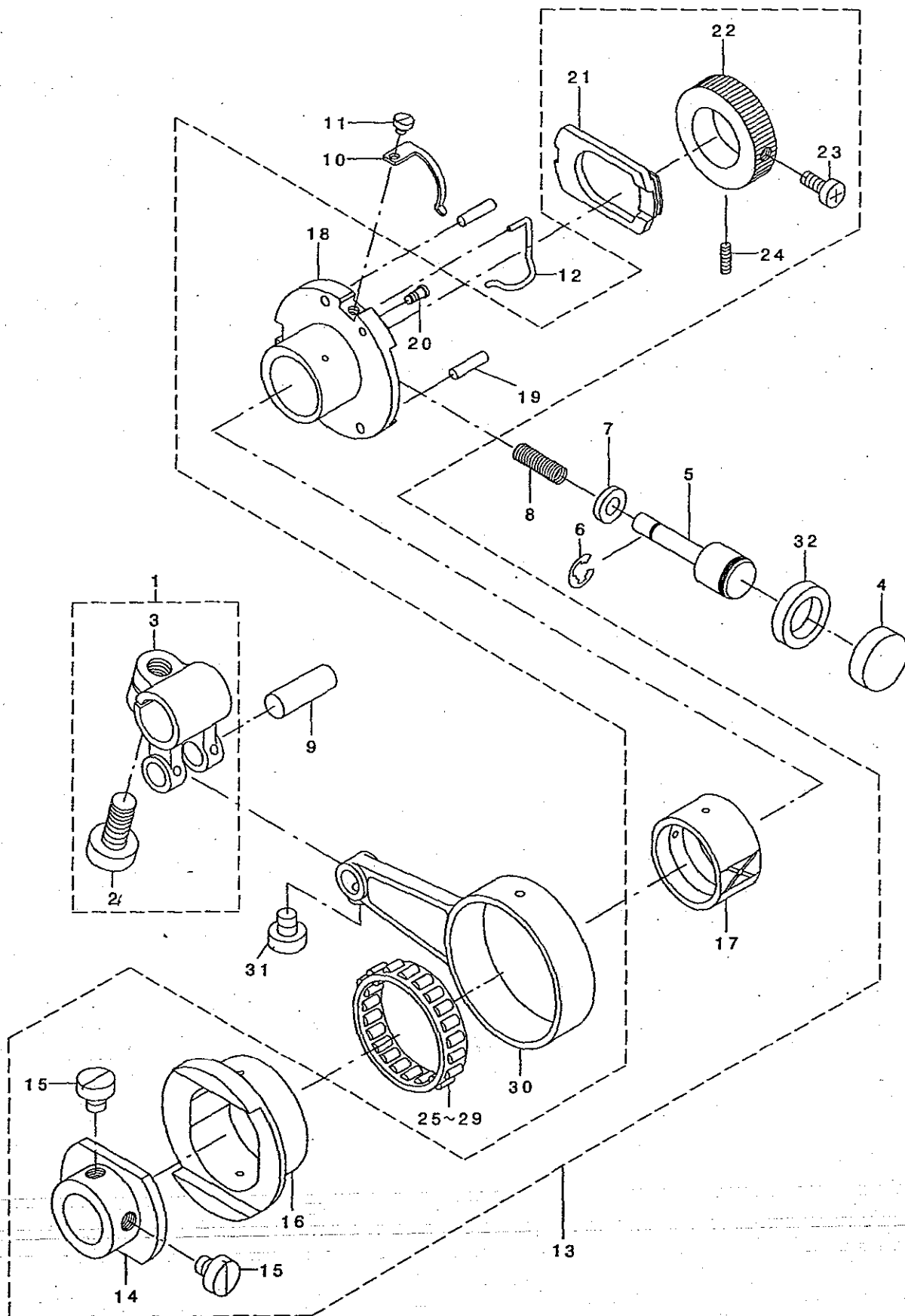

REF. NO	NOTE	PART NO.	DESCRIPTION	品名	Qty
1		122-09052	FORKEND CRANK ASM.	オクリフタマタクランクミ	1
2		SS-9151210-TP	SCREW 15/64-28 L=11.8	ロツカクネ ねト 15/64-28	(1)
3		122-09003	FORKEND CRANK	オクリフタマタクランク	(1)
4		122-11801	PUSH BOTTON CAP	オツボ タン キャップ	1
5		122-11702	PUSH BOTTON STUD	オツボ タンシク	1
6		RE-0320000-K0	E-RING 3.2	Eカ タメワ 3.2	1
7		121-18600	OIL SHEET	オツボ タンシク オイルシート	1
8		B1652-704-000	SPRING	オツボ タン ハネ	1
9	#01	118-23804	CRANK PIN C	オクリフタマタ クランクピン C	1
10		122-08807	RATCHET GEAR SPRING	ラチェット キヤハネ	1
11		SS-6080340-SP	SCREW 1/8-44 L=2.9	ヒラネジ 1/8-44 L=2.9	1
12		122-08609	RATCHET PAWL SPRING	ラチェット オサエハネ	1
13		122-08153	FEED CAM SUPPORT BASE	オクリカム シツダイクミ	1
14		122-08104	FEED ECCENTRIC BODY	オクリカム シツダイ	(1)
15		SS-6660710-TP	SCREW 1/4-40 L=7	ヒラネジ 1/4-40 L=7	(2)
16		122-08203	FEED CAM	オクリカム	(1)
17		122-08302	SLIDE BLOCK	オクリカム カクコマ	(1)
18		122-08401	FEED ADJUSTING CAM	オクリチヨウセツ カム	(1)
19		PS-0300132-KH	SPRING PIN 3X13	スプリング ピン	(2)
20		SD-0260271-SP	HINGE SCREW D= 2.60 H= 2.7	タネネジ D=2.6 H=2.7	(1)
21		122-08500	RATCHET PAWL	ラチェット	(1)
22		122-08708	RATCHET GEAR	ラチェットキヤ	(1)
23		SS-6111110-SP	SCREW 11/64-40 L=11.0	ヒラネジ 11/64-40 L=11	(1)
24		SS-8110520-TP	SCREW 11/64-40 L= 4.5	トメネジ 11/64-40 L=4.5	(1)
25	#01	SB-3350002-OA	BEARING	コロカ リジ クウケ	1
26	#01	SB-3350002-OB	BEARING	コロカ リジ クウケ	1
27	#01	SB-3350002-OC	BEARING	コロカ リジ クウケ	1
28	#01	SB-3350002-OD	BEARING	コロカ リジ クウケ	1
29	#01	SB-3350002-OE	BEARING	コロカ リジ クウケ	1
30		122-08906	CRANK ROD	オクリクランク ロット	1
31		SS-7110910-TP	SCREW 11/64-40 L= 8.5	マルヒラネジ 11/64-40 L=8.5	1
32		122-60303	PUSH BUTTON COLLAR	オツボ タンカラー	1
		NOTE (注記)	#01...SELECTIVE PART	選択部品	

6. FEED MECHANISM COMPONENTS(2)

送り関係(2)

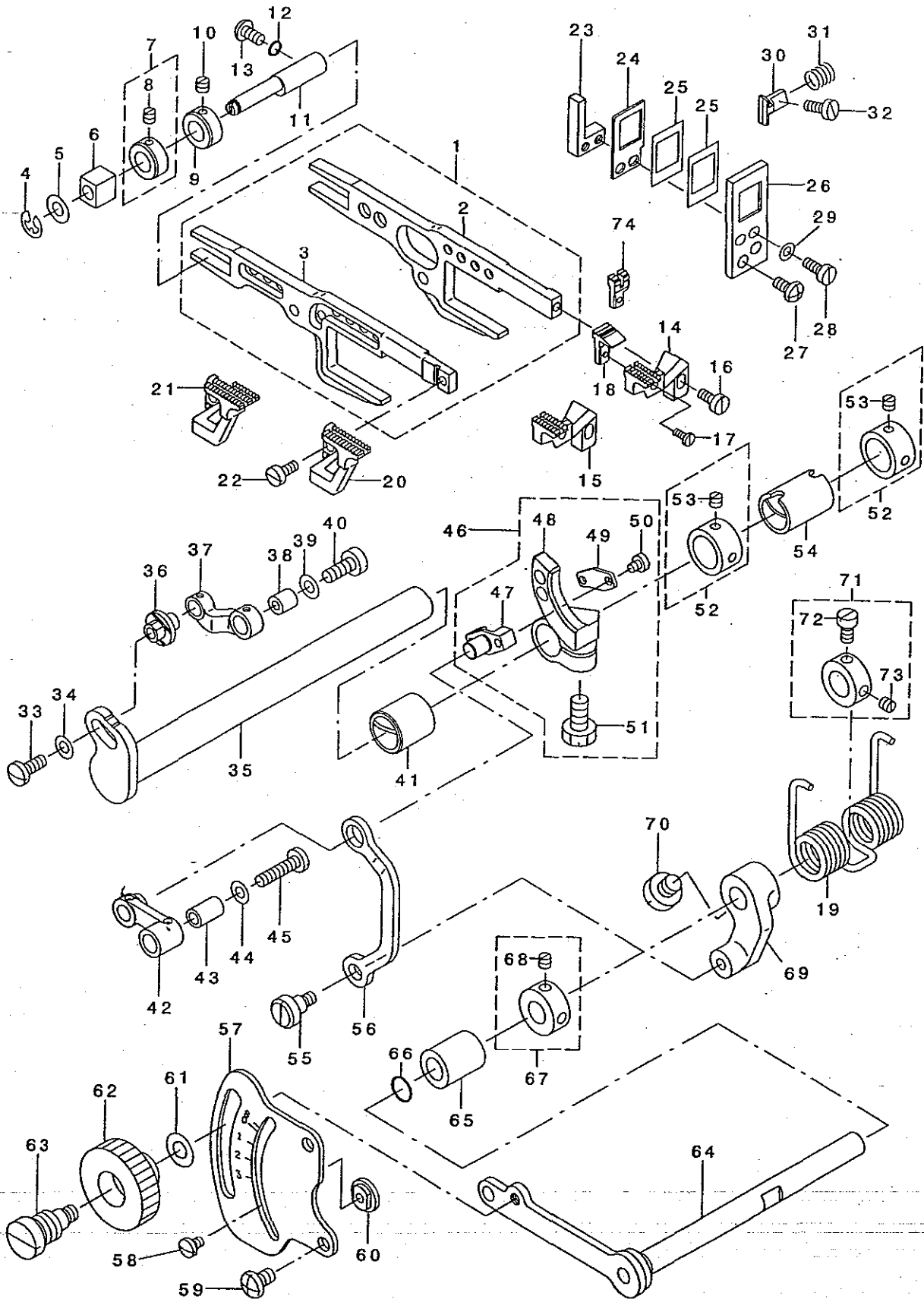

REF. NO	NOTE	PART NO.	DESCRIPTION	品名	Qty
1		122-09953	MAIN FEED BAR ASM.	シュネクリヨウトウウカン	1
2		122-09904	MAIN FEED BAR	シュネクリヨウトウウカン	(1)
3		122-10001	DIFFERENTIAL FEED BAR	フクネクリヨウトウウカン	(1)
4		RE-0400000-KO	E-SHAPED SNAP RING (4MM)	Eガナメツ4	1
5		115-29914	WASHER	ヨウトウカンチヂイクサガネ	1
6		122-10308	SLIDE BLOCK	ヨウトウカンチヂイカクゴマ	1
7		118-28050	COLLAR ASM.	チヂイシクカラクミ	1
8		SS-8110410-TP	SCREW 11/64-40 L= 3.5	トメネツ 11/64-40 L=3.5	(1)
9		CS-0790731-SH	THRUST COLLAR	スラストウケ	1
10		SS-8110410-TP	SCREW 11/64-40 L= 3.5	トメネツ 11/64-40 L=3.5	1
11		122-10217	FEED BAR SUPPORT SHAFT	ヨウトウカンチヂイシク	1
12		RO-0371801-00	RUBBER RING	Oリング	1
13		SM-4040855-SP	SCREW	ナメネツ	1
14	#01	122-35107	MAIN FEED DOG	シュネクリハ	1
15	#02	122-35206	MAIN FEED DOG	シュネクリハ	1
16		SS-6090810-TP	SCREW 9/64-40 L=7.5	ヒラネツ 9/64-40 L=7.5	1
17		SS-7060610-SP	SCREW 3/32-56 L= 5.5	マルヒラネツ 3/32-56 L=5.5	1
18		122-38101	AUXILIARY FEED DOG	ネツヨネクリハ	1
19		122-11504	SPRING	サトウチヨウセツレハハネ	1
20	#01	122-36600	DIFFERENTIAL FEED DOG	フクネクリハ	1
21	#02	122-36709	DIFFERENTIAL FEED DOG	フクネクリハ	1
22		SS-6090810-TP	SCREW 9/64-40 L=7.5	ヒラネツ 9/64-40 L=7.5	1
23		122-10605	FEED BAR SUPPORT, LEFT	ヨウトウカンチヂイヒタリ	1
24		122-10506	RUBBER SUPPORT	ホウシソコメチヂイ	1
25		121-18303	RUBBER	ホウシソコメ	2
26		122-10407	RUBBER CASE	ホウシソコメケース	1
27		SM-4040855-SP	SCREW	ナメネツ	2
28		SS-6090910-TP	SCREW 9/64-40 L=9	ヒラネツ 9/64-40 L=9	2
29		WP-0371026-SD	WASHER 3.7X7X1	ヒラネツガネ 3.7X7X1	2
30		122-10704	FEED BAR SUPPORT, RIGHT	ヨウトウカンチヂイミキ	1
31		122-10803	SPRING	ヨウトウカンチヂイハネ	1
32		SS-6110820-TP	SCREW	ヒラネツ	1
33		SS-6111010-TP	SCREW 11/64-40 L= 9.5	ヒラネツ 11/64-40 L=9.5	1
34		B3228-771-00B	BOBBIN WINDER SPACER	イトマキスハチ	1
35		122-09102	ROCKER SHAFT	ネクリシク	1
36		122-09201	MAIN FEED PIN	シュネクリピン	1
37		122-09300	MAIN FEED LINK	シュネクリリンク	1
38		B1620-804-000	COLLAR	シュネクリピンカラ	1
39		B1707-155-000	FEED DRIVING SLIDE BLOCK WASHE	ネクリカクゴマシクサガネ	1
40		SS-6121220-TP	SCREW 3/16-28 L=11.5	ヒラネツ 3/16-28 L=11.5	1
41		122-10902	BUSHING, FRONT	ネクリシクマシメタル	1
42		122-09805	LINK	フクネクリリンク	1
43		122-09706	COLLAR	フクネクリリンクカラ	1
44		WP-0451026-SH	WASHER	ヒラネツガネ	1
45		SS-7111810-TP	SCREW 11/64-40 L=18	マルヒラネツ 11/64-40 L=18	1
46		122-09458	SUB-FEED ARM ASM.	フクネクリウデ(クミ)	1
47		122-09508	PIN	フクネクリピン	(1)
48		122-09409	FEED ROCKER	フクネクリウデ	(1)
49		122-09607	PIN COVER	フクネクリピンフタ	(1)
50		SS-6080410-SP	SCREW 1/8-44 L=4	ヒラネツ 1/8-44 L=4	(2)
51		SS-9151210-TP	SCREW 15/64-28 L=11.8	ロカカホメ 15/64-28	(1)
52		CS-120101B-SH	THRUST COLLAR ASM.	スラストウケクミ	2
53		SS-8660410-SP	SCREW 1/4-40 L= 4.2	トメネツ 1/4-40 L=4.2	(4)
54		122-11009	BUSHING, REAR	ネクリシクウロメタル	1
55		SD-0640321-TP	HINGE SCREW	ダンネツ	1
56		122-11405	LINK	サトウチヨウセツリンク	1
57		122-11603	DIFFERENTIAL FEED GRADUATION	サトウチヨウセツメモリイ	1
58		SS-7090540-TP	SCREW 9/64-40 L=5	マルヒラネツ 9/64-40 L=5	2
59		SM-4050855-SP	SCREW M5 L=8	ナメネツ M5 L=8	2
60		115-29005	STOPPER	サトウチヨウセツストップ	2
61		WP-0621016-SD	WASHER 6.2X13X1	ヒラネツガネ 6.2X13X1	1
62		B1647-704-000-A	DIFFERENTIAL FEED LOCK NUT	サトウチヨウセツナット	1
63		B1646-704-000-A	DIFFERENTIAL FEED HINGE SCREW	サトウチヨウセツ	1
64		122-11157	ROCKER SHAFT ASM.	サトウチヨウセツシククワコウ	1
65		121-18709	ROCKER SHAFT METAL	サトウチヨウセツシクメタル	1
66		RO-0601501-00	RUBBER RING	Oリング	1
67		CS-087081B-SH	THRUST COLLAR ASM.	スラストカラクミ	1
68		SS-8110410-TP	SCREW 11/64-40 L= 3.5	トメネツ 11/64-40 L=3.5	(2)
69		122-11306	DIFFERENTIAL FEED ROCKER	サトウチヨウセツウデ	1
70		SS-6660610-TP	SCREW 1/4-40 L=6	ヒラネツ 1/4-40 L=6	1
71		CS-087081C-SH	THRUST COLLAR ASM.	スラストカラクミ	1
72		B1536-804-000	PIN	チヂイシクスラストウデピン	(1)
73		SS-8110410-TP	SCREW 11/64-40 L= 3.5	トメネツ 11/64-40 L=3.5	(1)
74	#03	122-38200	AUXILIARY FEED DOG	ネツヨネクリハ	1

NOTE (注記)

#01.... FOR SP161S400M032
 #02.... FOR SP172S400MACC
 #03.... P04/Q01 EXCHANGING PARTS

SP161S400M032用
 SP172S400MACC用
 P04/Q01交換部品

7. UPPER FEED MECHANISM COMPONENTS(1)

上送り関係(1)

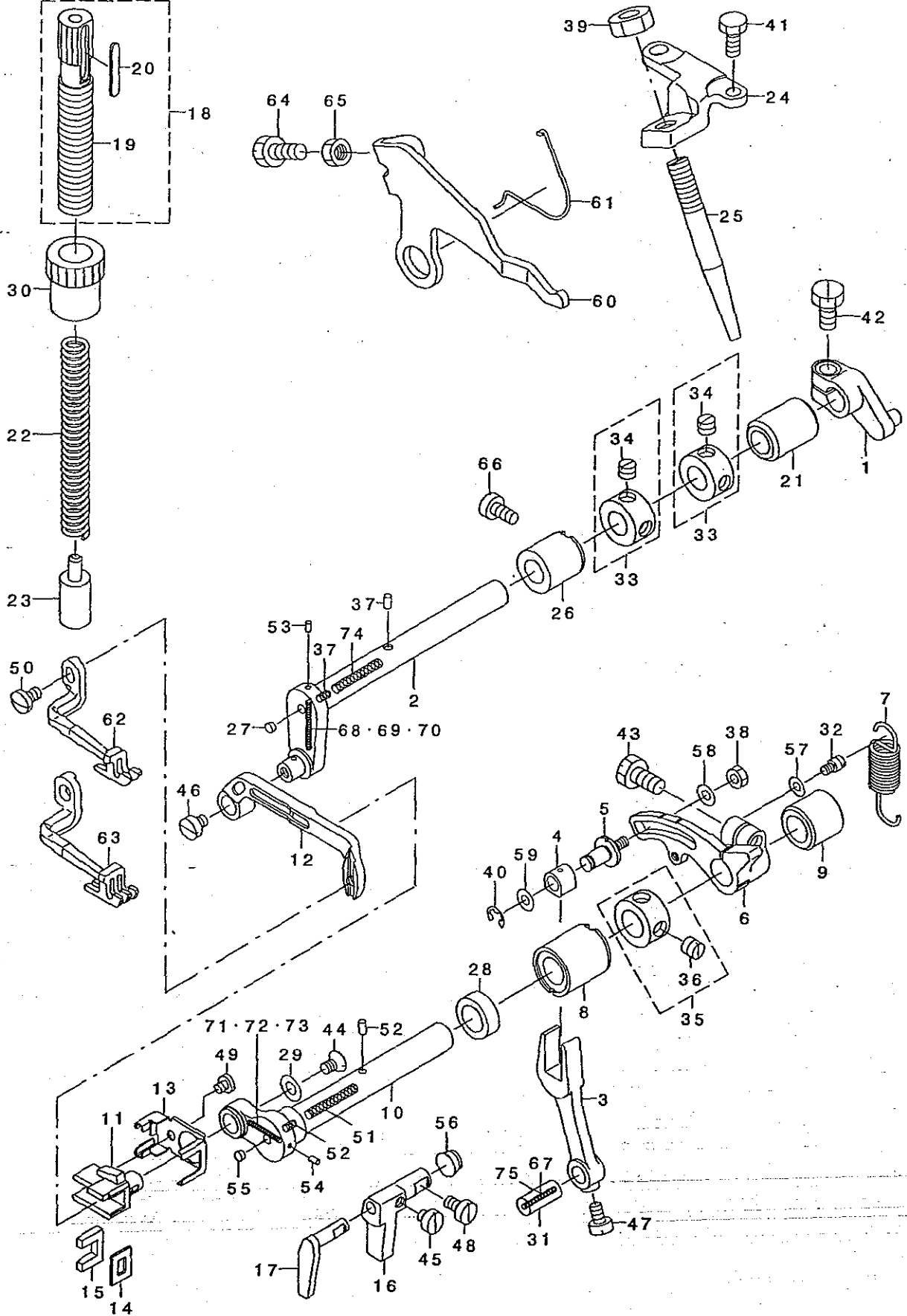

REF. NO	NOTE	PART NO.	DESCRIPTION	キ ャ ン ン	Qty
1		123-09100	HORIZONTAL ARM C	スイハウテ C	1
2		122-92603	HORIZONTAL SHAFT	スイハウシク	1
3		123-09308	VERTICAL ROD	ジ ヨウケ ロット	1
4		123-09407	VERTICAL SLIDE BLOCK	ジ ヨウケ カクコマ	1
5		123-09506	VERTICAL ADJUST PIN	ジ ヨウケ チョウセツピン	1
6		123-09605	VERTICAL ADJUST ARM	ジ ヨウケ チョウセツワラテ	1
7		123-09704	ADJUST ARM SPRING	チョウセツワラテ ハ ネ	1
8		123-09803	VERTICAL SHAFT FRONT METAL	ジ ヨウケ シク マエメタル	1
9		123-09902	VERTICAL SHAFT REAR METAL	ジ ヨウケ シク クウシロメタル	1
10		123-10009	VERTICAL SHAFT	ジ ヨウケ シク	1
11		123-10108	UPPER FEED SLIDE BLOCK	ウラネクリカクコマ	1
12		123-10207	UPPER FEED BAR	ウラネクリヨウト ウカン	1
13		123-10306	OIL THROWER RUBBER PRESSER	アッ ラキリゴ ムサエ	1
14		123-10405	OIL THROWER RUBBER	アッ ラキリゴ ム	1
15		123-10504	FEED BAR FELT	ヨウト ウカンキョウコフエルト	1
16		123-10603	GUIDE A	ヨウト ウカンガ イト A	1
17		123-10702	GUIDE B	ヨウト ウカンガ イト B	1
18		123-10850	ADJUST SCREW ASM.	ウラネキエチヨウセツネジ クミ	1
19		123-10801	UPPER PRESSER ADJUST SCREW	ウラネキエチヨウセツネジ	(1)
20		123-10900	ADJUST SCREW SCALE PLATE	チョウセツネジ メモリタ	(1)
21		123-08409	METAL, REAR	スイハウト ウラ クウシロメタル	1
22		123-11007	UPPER PRESSER SPRING	ウラネキエハ ネ	1
23		123-11106	UPPER PRESSER BLOCK	ウラネキエコマ	1
24		123-12203	SHAFT SCREW BACE	キセキカクシイ	1
25		123-12302	SHAFT SCREW	キセキカクシネジ	1
26		123-08300	METAL, FLONT	スイハウト ウラ クマエメタル	1
27		TA-0340201-RO	PLUG D=3.4X3.9 L=2	トメシ D=3.4X3.9 L=2	1
28		115-66809	OIL SEAL	ウラメシク ネイシール	1
29		119-13407	SLIDE BLOCK WASHER	ウラネクリ カクコマサ カネ	1
30		119-14405	NUT	チョウセツ ネジ ナット	1
31	#03	B1612-804-C00	CRANK PIN C	ウラネクリカクコマ クラックピン C	1
32		B2024-771-000	SUSPENSION SCREW	ウラネクリ ハ ネカ	1
33		CS-100101E-SH	THRUST COLLAR ASM.	スイハウシク クラスターカネ (クミ)	2
34		SS-8660530-TP	SCREW 1/4-40 L= 4.5	トメネジ 1/4-40 L=4.5	(2)
35		CS-111101H-SH	THRUST COLLAR ASM.	ジ ヨウケ シク クラスターカネ (クミ)	1
36		SS-8660330-SP	SCREW 1/4-40 L= 3.0	トメネジ 1/4-40 L=3	(1)
37		B3525-704-000	OIL FELT	ハリクト - マエメタル フェルト	2
38		NW-6040000-SN	NUT M4	ロツカクナット M4	1
39		NW-6080011-SF	NUT M8	ロツカクナット M8 シュ	1
40		RE-0400000-KO	E-RING 4	Eガ 外メツ 4	1
41		SM-9051203-CP	SCREW M5 L=12	ロツカクネ ねト M5 L=12	2
42		SM-9061250-TP	SCREW M6 L=12	ロツカクネ ねト M6 L=12	1
43		SM-9061250-TP	SCREW M6 L=12	ロツカクネ ねト M6 L=12	1
44		SS-2110710-TP	SCREW 11/64-40 L=7	マシラネジ 11/64-40 L=7	1
45		SS-6110420-TP	SCREW 11/64-40 L=4.8	ヒラネジ 11/64-40 L=4.8	1
46		SS-6110520-TP	SCREW 11/64-40 L=4.5	ヒラネジ 11/64-40 L=4.5	1
47		SS-6110710-TP	SCREW 11/64-40 L= 6.5	ヒラネジ 11/64-40 L=6.5	1
48		SS-6110820-TP	SCREW 11/64-40 L=8	ヒラネジ 11/64-40 L=8	1
49		SS-7090410-SP	SCREW 9/64-40 L= 3.5	マシラネジ 9/64-40 L=3.5	1
50		SS-7110740-TP	SCREW 11/64-40 L=7	マシラネジ 11/64-40 L=7	1
51		123-17202	OIL WICK (HORIZONTAL)	ジ ヨウケ シク アッ ラン (ヨ)	1
52		B3525-704-000	OIL FELT	ハリクト - マエメタル フェルト	2
53		TA-0180401-MO	NEEDLE COOLER PLUG CAP	トメシ D=1.8X2.1 L=4.3	1
54		TA-0180401-MO	NEEDLE COOLER PLUG CAP	トメシ D=1.8X2.1 L=4.3	1
55		TA-0340201-RO	PLUG D=3.4X3.9 L=2	トメシ D=3.4X3.9 L=2	1
56		TA-0800501-RO	PLUG D=8X8.2 L=5	トメシ D=8X8.2 L=5	1
57		WP-0371036-SD	WASHER 3.7X6X1	ヒラサ カネ 3.7X6X1	1
58		WP-0451026-SH	WASHER	ヒラサ カネ	1
59		WP-0621016-SH	WASHER	ヒラサ カネ	1
60		123-05405	UPPER FEED DOG LIFTER B	ウラネクリハ リフターB	1
61		123-05504	UPPER FEED DOG LIFTER B SPRING	リフターB ハネ	1
62	#01	119-36614	TOP FEED DOG	ウラネクリハ	1
63	#02	119-36804	TOP FEED DOG	ウラネクリハ	1
64		SS-9151210-TP	SCREW 15/64-28 L=11.8	ロツカクネ ねト 15/64-28	1
65		NS-6150430-SP	NUT 15/64-28	ロツカクナット 15/64-28	1
66		SS-6121020-SP	SCREW 3/16-28 L= 9.5	ヒラネジ 3/16-28 L=9.5	1
67		CQ-2020000-00	OIL WICK	ユツ	0.04
68	#03	123-16600	OIL WICK(VERTICAL C)	スイハウシク アッ ラン (タテC)	1
69	#03	123-16402	OIL WICK(VERTICAL A)	スイハウシク アッ ラン (タテA)	1
70	#03	123-16501	OIL WICK(VERTICAL B)	スイハウシク アッ ラン (タテB)	1
71	#03	123-16709	OIL WICK(VERTICAL A)	ジ ヨウケ シク アッ ラン (タテA)	1
72	#03	123-16808	OIL WICK(VERTICAL B)	ジ ヨウケ シク アッ ラン (タテB)	1
73	#03	123-16907	OIL WICK(VERTICAL C)	ジ ヨウケ アッ ラン (タテC)	1
74		123-17103	OIL WICK(HORIZONTAL)	スイハウシク アッ ラン (ヨ)	1
75		CQ-2520000-00	OIL WICK	ユツ	0.04

NOTE (注記)

#01... FOR SP161S400M032
 #02... FOR SP172S400MACC
 #03... SELECTIVE PART

SP161S400M032用
 SP172S400MACC用
 選択部品

8. UPPER FEED MECHANISM COMPONENTS(2)

上送り関係(2)

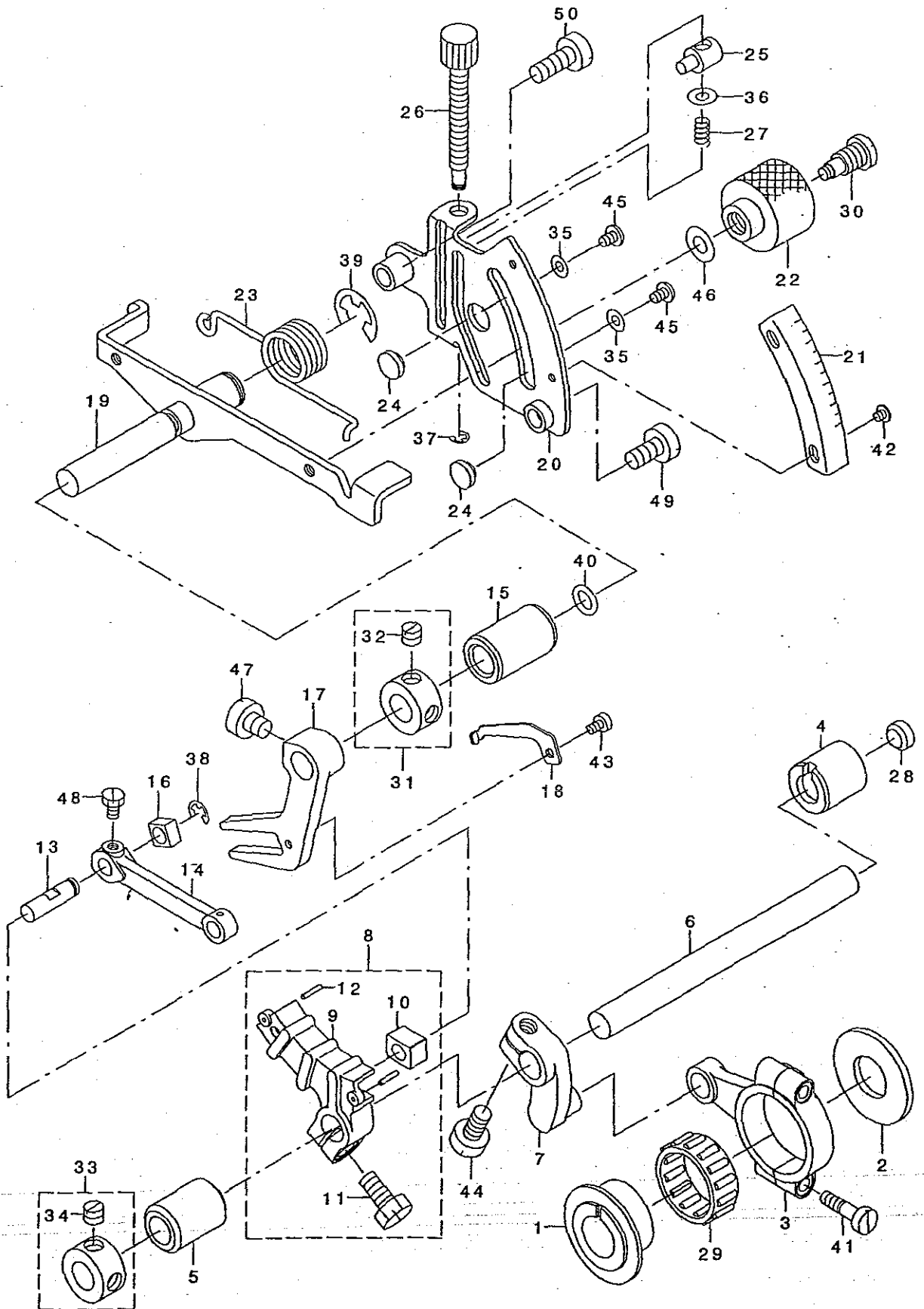

REF. NO	NOTE	PART NO.	DESCRIPTION	ヒョウメイ	Qty
1		123-08003	HORIZONTAL FEED CAM	スイハイクリカム	1
2		123-08102	CAM SPACER	カムスパーサー	1
3		123-08201	HORIZONTAL ROD	スイハイロッド	1
4		123-08300	METAL, FLONT	スイハイクトウジクマエメタル	1
5		123-08409	METAL, REAR	スイハイクトウジクウシロメタル	1
6		122-92504	HORIZONTAL DRIVING SHAFT	スイハイクトウジク	1
7		123-08607	HORIZONTAL ARM A	スイハイクア	1
8		123-08755	HORIZONTAL ARM B ASM.	スイハイクア B クミ	1
9		123-08706	HORIZONTAL ARM B	スイハイクア B	(1)
10		123-08805	HORIZONTAL SLIDE BLOCK	スイハイクコマ	(1)
11		SM-9061250-TP	SCREW M6 L=12	ロツカクネ M6 L=12	(1)
12		PS-0150082-KH	SPRING PIN	スプリングピン	(2)
13		123-08904	HORIZONTAL FEED PIN	スイハイククリピン	1
14		123-09001	HORIZONTAL FEED LINK	スイハイククリリンク	1
15		122-92702	ADJUSTING SHAFT METAL	ウツネクリチヨウセツジクメタル	1
16		123-11304	HORIZONTAL SLIDE BLOCK B	スイハイクコマB	1
17		123-11403	HORIZONTAL BRANCH ARM	スイハイクタマタウデ	1
18		123-11502	HORIZONTAL BRANCH STOPPER	スイハイクタマタストップパ	1
19		122-92850	ADJUSTING SHAFT ASM.	ウツネクリチヨウセツジク	1
20		123-11809	UPPER FEED SCALE PLATE	ウツネクリメモリイタ	1
21		123-11908	UPPER FEED SCALE PLATE B	ウツネクリメモリイタB	1
22		123-12005	UPPER FEED LOCK NUT	ウツネクリロックナット	1
23		123-12104	UPPER FEED LEVER SPRING	ウツネクリレバハネ	1
24		115-29005	STOPPER	サトチヨウセツジクストップパ	2
25		118-26005	DIFFERENTIAL FEED BLOCK	サトヒチヨウセツコマ	1
26		118-26104	DIFFERENTIAL FEED SCREW	サトヒチヨウセツネジ	1
27		118-26203	SPRING	サトヒチヨウセツネジハネ	1
28		118-98400	RUBBER PLUG B	ヌメダイホクシンセンB	1
29	#01	121-16703	NEEDLE BEARING B	ネクリハアリソク B	1
30		B1646-704-000-A	DIFFERENTIAL FEED HINGE SCREW	サトダンネジ	1
31		CS-100101E-SH	THRUST COLLAR ASM.	スイハイクスラストカラー(クミ)	1
32		SS-8660530-TP	SCREW 1/4-40 L= 4.5	トメネジ 1/4-40 L=4.5	(1)
33		CS-100101E-SH	THRUST COLLAR ASM.	スイハイクスラストカラー(クミ)	1
34		SS-8660530-TP	SCREW 1/4-40 L= 4.5	トメネジ 1/4-40 L=4.5	(1)
35		WP-0371016-SD	WASHER 3.7X8X1	ヒラサカネ 3.7X8X1	2
36		WP-0460556-SD	WASHER 4.6X7.5X0.5	ヒラサカネ 4.6X7.5X0.5	1
37		RE-0300000-KO	E-RING 3	Eガタメツ 3	1
38		RE-0400000-KO	E-RING 4	Eガタメツ 4	1
39		RE-0900000-KO	E-RING 9	Eガタメツ 9	1
40		RO-0681901-00	RUBBER RING	オリソク	1
41		SD-0461001-SP	HINGE SCREW D= 4.6 H=10	ダンネジ D=4.6 H=10	2
42		SM-0030301-SN	SCREW	トラスネジ M3 L=3	2
43		SM-6030510-SC	SCREW M3X0.5 L=5	ヒラコネジ M3X0.5 L=5	1
44		SM-9061250-TP	SCREW M6 L=12	ロツカクネ M6 L=12	1
45		SS-4090515-SP	SCREW 9/64-40 L=5	ナネネジ 9/64-40 L=5	2
46		WP-0621016-SD	WASHER 6.2X13X1	ヒラサカネ 6.2X13X1	1
47		SS-6660710-TP	SCREW 1/4-40 L=7	ヒラネジ 1/4-40 L=7	1
48		SS-9090610-TP	SCREW 9/64-40 L=5.5	ロツカクネ M6 9/64-40 L=5.5	1
49		SM-6061210-SC	SCREW M6 L=12	ヒラコネジ M6 L=12	1
50		SM-6061610-SC	SCREW M6 L=16	ヒラコネジ M6 L=16	1

NOTE (注記) #01....SELECTIVE PART

選択部品

9. UPPER & LOWER LOOPER COMPONENTS

上ルーパ、下ルーパ関係

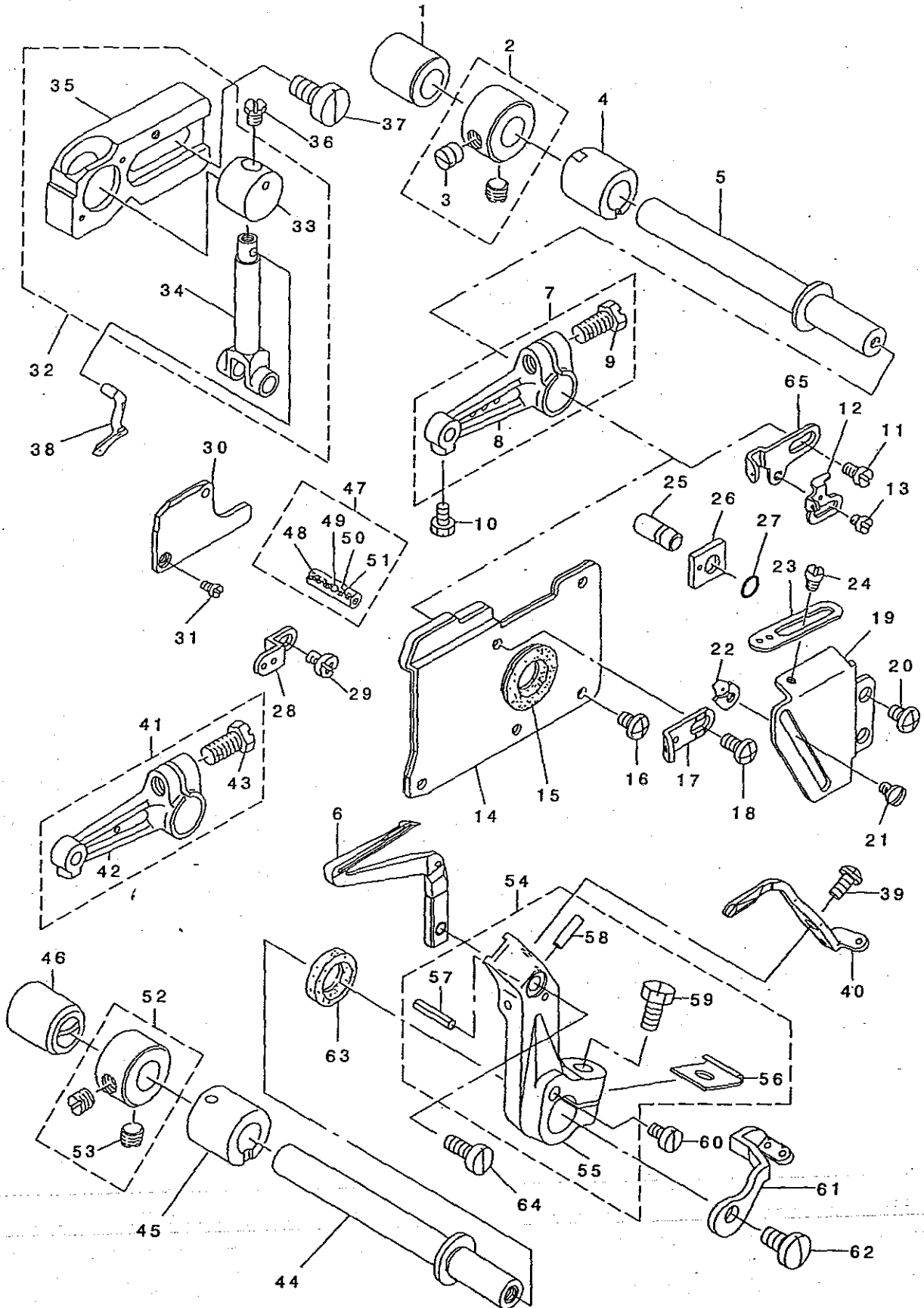

REF. NO.	NOTE	PART NO.	DESCRIPTION	品名	Qty
1		121-22610	LOOPER SHAFT REAR BUSHING	ル-ハ-シクウシロメタル	1
2		CS-1031210-SH	THRUST COLLAR ASM. D=10.32 W=1	スラストウケ D=10.32 W=12 クミ	1
3		SS-8660610-TP	SCREW 1/4-40 L=6	トメネジ 1/4-40 L=6	(2)
4		121-22511	LOOPER SHAFT FRONT BUSHING	ル-ハ-シクウシロメタル	1
5		121-22404	UPPER LOOPER SHAFT	ウエ ル-ハ-シク	1
6		122-40107	LOWER LOOPER	シタ ル-ハ-	1
7	#02	122-14656	UPPER LOOPER ARM D ASM.	ウエル-ハ-ウデ D(クミ)	1
8		122-14607	UPPER LOOPER ARM D	ウエル-ハ-ウデ D	(1)
9		SS-9151210-TP	SCREW 15/64-28 L=11.8	ロツカクネ 15/64-28	(1)
10		SS-9090610-TP	SCREW 9/64-40 L=5.5	ロツカクネ 9/64-40 L=5.5	1
11		SS-7110840-SP	SCREW 11/64-40 L=7.8	マヒラネジ 11/64-40 L=7.8	1
12		118-33506	LOWER LOOPER THREAD TAKE-UP	シタ ル-ハ テンビン	1
13		SS-6080410-SP	SCREW 1/8-44 L=4	ヒラネジ 1/8-44 L=4	1
14		122-15554	OIL SHIELD PLATE ASM.	ル-ハ-ガ イト コネ ウハシクミ	1
15		B2530-704-000	UPPER LOOPER SHAFT RUBBER RING	ウエル-ハ シク コ アツ	1
16		SS-6090630-SP	SCREW 9/64-40 L=6	ヒラネジ 9/64-40 L=6	4
17		121-24202	UPPER LOOPER THREAD GUIDE	ウエル-ハ イトアソナイ チユ	1
18		SS-7090850-SP	SCREW 9/64-40 L=8	マヒラネジ 9/64-40 L=8	1
19		121-23808	LOOPER THREAD TAKE-UP COVER	ル-ハ-テンビンシカハ	1
20		SM-4040655-SP	SCREW	ナハ コネジ M4 L=6	2
21		SS-3090610-SP	SCREW 9/64-40 L=6	マヒラネジ 9/64-40 L=6	1
22		118-33407	LOWER LOOPER THREAD GUIDE	シタ ル-ハ イトアソナイ	1
23		121-23907	THREAD GUIDE, RIGHT	ウエ ル-ハ-イトアソナイ ミキ	1
24		SS-3090610-SP	SCREW 9/64-40 L=6	マヒラネジ 9/64-40 L=6	1
25		118-31906	PIN	ケ-シク コテイビン	1
26		118-31807	GAUGE	ウエル-ハ ガ イト シチエク-シ	1
27		RO-0371801-00	RUBBER RING	Oリング	1
28		122-15703	LOOPER THREAD GUIDE, UPPER	ウエ ル-ハ- イトアソナイ(ウエ)	1
29		SS-4090615-SP	SCREW 9/64-40 L=6	ナハ ネジ 9/64-40 L=6	1
30		122-14805	UPPER LOOPER GUIDE COVER	ウエ ル-ハ-ガ イト フタ	1
31		SS-7060610-SP	SCREW 3/32-56 L=5.5	マヒラネジ 3/32-56 L=5.5	2
32		122-14755	UPPER LOOPER GUIDE ASM.	ウエル-ハ-ガ イト シチエクミ	1
33		121-23204	UPPER LOOPER GUIDE	ウエル-ハ-ガ イト	(1)
34		121-22909	UPPER LOOPER HOLDER	ウエ ル-ハ-ダキ	(1)
35		122-14706	UPPER LOOPER GUIDE SUPPORT	ウエ ル-ハ-ガ イト シチエ	(1)
36		SS-9090410-TP	SCREW	ロツカクネ 15	1
37		SM-6061200-SP	SCREW M6 L=12	ヒラネジ M6 L=12	2
38		122-47300	UPPER LOOPER	ウエ ル-ハ-	1
39		SS-4080610-SP	SCREW 1/8-44 L=6.4	ナハ ネジ 1/8-44 L=6.4	1
40		122-40602	NEEDLE GUARD	イトウ ハツカ	1
41	#01	121-22859	UPPER LOOPER ARM B ASM.	ウエ ル-ハ-ウデ B クミ	1
42		121-22800	UPPER LOOPER ARM B	ウエ ル-ハ-ウデ B	(1)
43		SS-9151210-TP	SCREW 15/64-28 L=11.8	ロツカクネ 15/64-28	(1)
44		122-15208	LOWER LOOPER SHAFT	シタ ル-ハ-シク	1
45		122-14904	LOWER LOOPER BUSHING, FRONT	シタ ル-ハ-シク マメタル	1
46		122-15000	LOWER LOOPER BUSHING, REAR	シタ ル-ハ-シク ウラロメタル	1
47	#03	118-31757	PIN ASM.	ウエル-ハ ダキ ビン クミ	1
48		115-17000	PIN C	ハリクト-レハ- ビン C	(1)
49		118-31708	OIL WICK STOPPER BALL	ユツトメタ マ	(1)
50		CQ-2020000-00	OIL WICK	ユツシ	(0.04)
51		CQ-2000000-00	OIL WICK	ユツシ	(0.04)
52		CS-100101D-SH	THRUST COLLAR ASM.	スラストカラ- クミ	1
53		SS-8660530-TP	SCREW 1/4-40 L=4.5	トメネジ 1/4-40 L=4.5	(2)
54		122-15356	LOWER LOOPER ARM ASM.	シタ ル-ハ-ウデ クミ	1
55		122-15307	LOWER LOOPER ARM	シタ ル-ハ-ウデ	(1)
56		B2531-704-000	WASHER	シク ウデ シメワツツキ	(1)
57		PS-0200062-KH	SPRING PIN 2X6	スプリング ビン 2X6	(1)
58		135-08700	HOOK COVER PRESSER SPRING PIN	カマカハ- オチエハ-ネビシ	(1)
59		SS-9151210-TP	SCREW 15/64-28 L=11.8	ロツカクネ 15/64-28	(1)
60		SS-6090630-TP	SCREW 9/64-40 L=6	ヒラネジ 9/64-40 L=6	1
61		122-15604	LOOPER THREAD TAKE-UP, LEFT	ル-ハ-テンビン (ヒダリ)	1
62		SS-6111140-SP	SCREW 11/64-40 L=11	ヒラネジ 11/64-40 L=11	1
63		122-15406	OIL SEAL	シタ ル-ハ-シク オイルシール	1
64		SS-6090610-SP	SCREW 9/64-40 L=6.0	ヒラネジ	1
65		121-24004	THREAD TAKE-UP, RIGHT	ウエル-ハ-テンビン ミキ	1

NOTE (注記)

#01....FOR SP161S400M032

#02....FOR SP172S400M032

#03....SELECTING PART FOR FIT TOLERANCE

SP161S400M032用

SP172S400M032用

選択かん合部品

10. PRESSER FOOT COMPONENTS(1)

押え関係 (1)

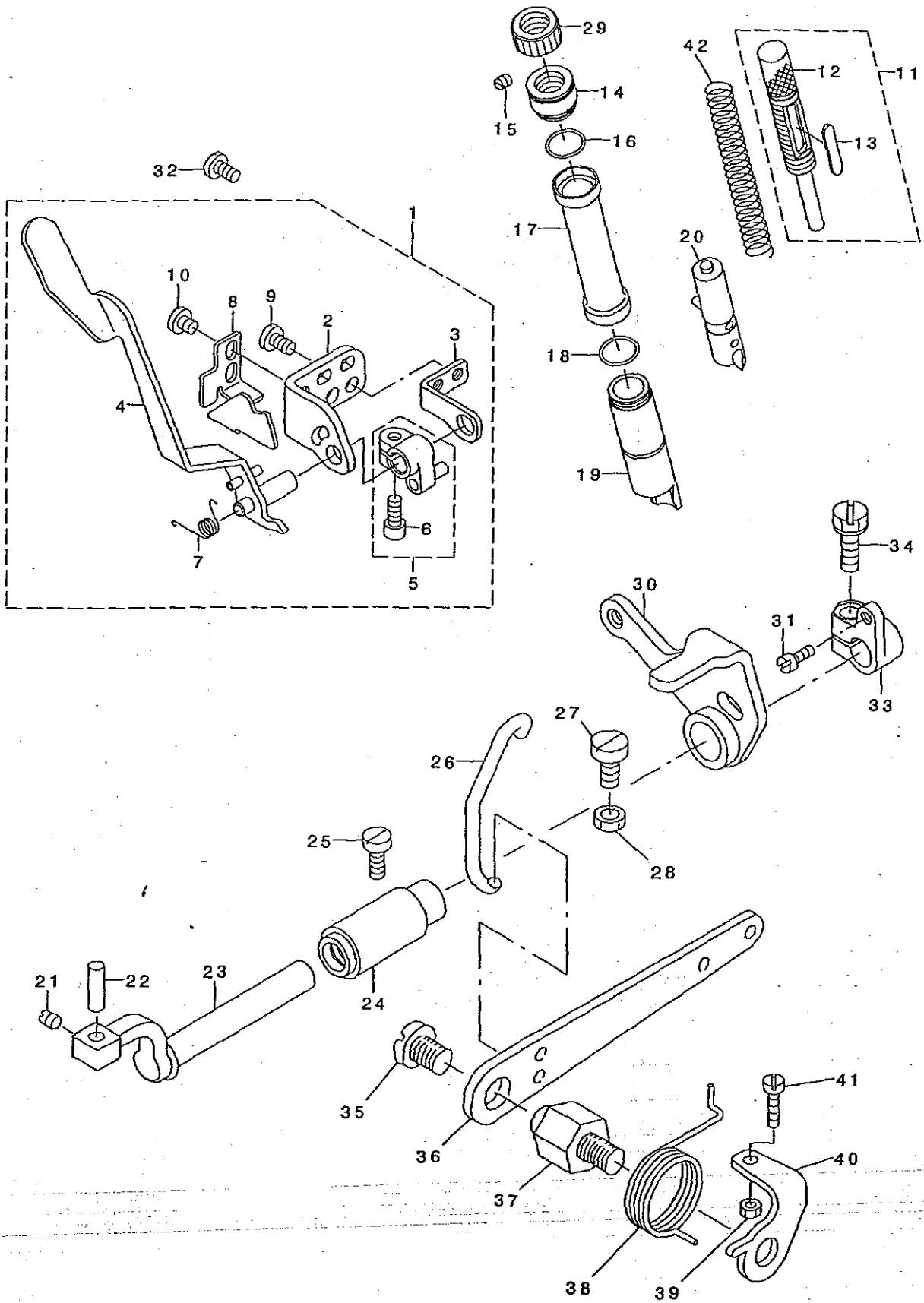

REF. NO	NOTE	PART NO.	DESCRIPTION	ヒョウメイ	Qty
1		123-06155	FOOT LIFTING LEVER STAND ASM.	オサエヒキアゲレハ-タ'イクミ	1
2		123-06106	FOOT LIFTING LEVER STAND A	オサエヒキアゲレハ-タ'IA	(1)
3		123-06205	FOOT LIFTING LEVER STAND B	オサエヒキアゲレハ-タ'IB	(1)
4		123-06353	FOOT LIFTING LEVER ASM.	オサエヒキアゲレハ-ケツコ'ウ	(1)
5		123-06551	UPPER FEED DOG LIFTER A ASM.	ウツオクリハ'リフタ-Aクミ	(1)
6		SS-6111052-TP	SCREW	ロツカクアナホ'ルト	(1)
7		123-06601	FOOT LIFTING SPRING	オサエヒキアゲレハ'ネ	(1)
8		123-06700	PRESSER ARM STOPPER	オサエウデ'ストッパ'-	(1)
9		SS-7110840-SP	SCREW 11/64-40 L=7.8	マルヒラネジ' 11/64-40 L=7.8	(2)
10		SS-7110510-SP	SCREW 11/64-40 L=5	マルヒラネジ' 11/64-40 L=5	(2)
11		123-05959	PRESSER ADJUST SCREW ASM.	オサエチヨウセツネジ'クミ	1
12		123-05900	PRESSER REGULATOR SCREW	オサエチヨウセツネジ'	(1)
13		123-10900	ADJUST SCREW PLATE	チヨウセツネジ'メモリタ	(1)
14		121-14609	PRESSER REGULATOR SCREW WASHER	オサエチヨウセツネジ'サ'	1
15		SM-8040402-TP	SCREW M4X0.7 L=4	トメネジ' M4X0.7 L=4	1
16		RO-1100901-00	RUBBER RING	オリツク'	1
17		121-14906	PRESSER BAR COVER	オサエホ'ウカハ'-	1
18		RO-1100901-00	RUBBER RING	オリツク'	2
19		123-05702	PRESSER BAR METAL	オサエホ'ウメタル	1
20		123-05850	PRESSER BAR ASM.	オサエホ'ウクミ	1
21		SS-8110520-TP	SCREW 11/64-40 L= 4.5	トメネジ' 11/64-40 L=4.5	1
22		B1534-804-000	PRESSER FOOT ARM HINGE SHAFT	オサエウデ'ヒンジ'ツ'ク	1
23		121-13205	PRESSER SHAFT	オサエツ'ク	1
24		123-05009	PRESSER SHAFT METAL	オサエツ'クメタル	1
25		SS-6121020-SP	SCREW 3/16-28 L= 9.5	ヒラネジ' 3/16-28 L=9.5	1
26		123-06809	PRESSER LIFTING HOOK	オサエアゲ'フック	1
27		SM-6061200-SP	SCREW M6 L=12	ヒラネジ' M6 L=12	1
28		NM-6060003-SC	NUT M6	ロツカクナツト M6	1
29		121-14807	PRESSER REGULATOR NUT	オサエ チヨウセツナツト	1
30		123-05256	PRESSER LIFTING ARM ASM.	オサエアゲ'ウデ'ケツコ'ウ	1
31		SS-6110710-TP	SCREW 11/64-40 L= 6.5	ヒラネジ' 11/64-40 L=6.5	1
32		SS-7110840-SP	SCREW 11/64-40 L=7.8	マルヒラネジ' 11/64-40 L=7.8	2
33		121-13817	PRESSER SHAFT THRUST ARM	オサエツ'クストラストウデ'	1
34		SS-9151210-TP	SCREW 15/64-28 L=11.8	ロツカクホ'ルト 15/64-28	1
35		SS-7161040-SP	SCREW 1/4-24 L= 9.5	マルヒラネジ' 1/4-24 L=9.5	1
36		118-19315	LIFTING LEVER	オサエアゲ'レハ'-	1
37		118-19109	LIFTING LEVER SCREW	オサエアゲ'レハ'-ネジ'	1
38		122-06702	LIFTING LEVER SPRING	オサエアゲ'レハ'-ハ'ネ	1
39		NS-6110420-SP	NUT 11/64-40	ロツカクナツト 11/64-40	1
40		122-06603	LEVER STOPPER	オサエアゲ'レハ'-ストッパ'-	1
41		SS-7111410-SP	SCREW 11/64-40 L=14	マルヒラネジ' 11/64-40 L=14	1
42		121-15903	PRESSER SPRING	オサエハ'ネ	1

11. PRESSER FOOT COMPONENTS(2)

押え関係 (2)

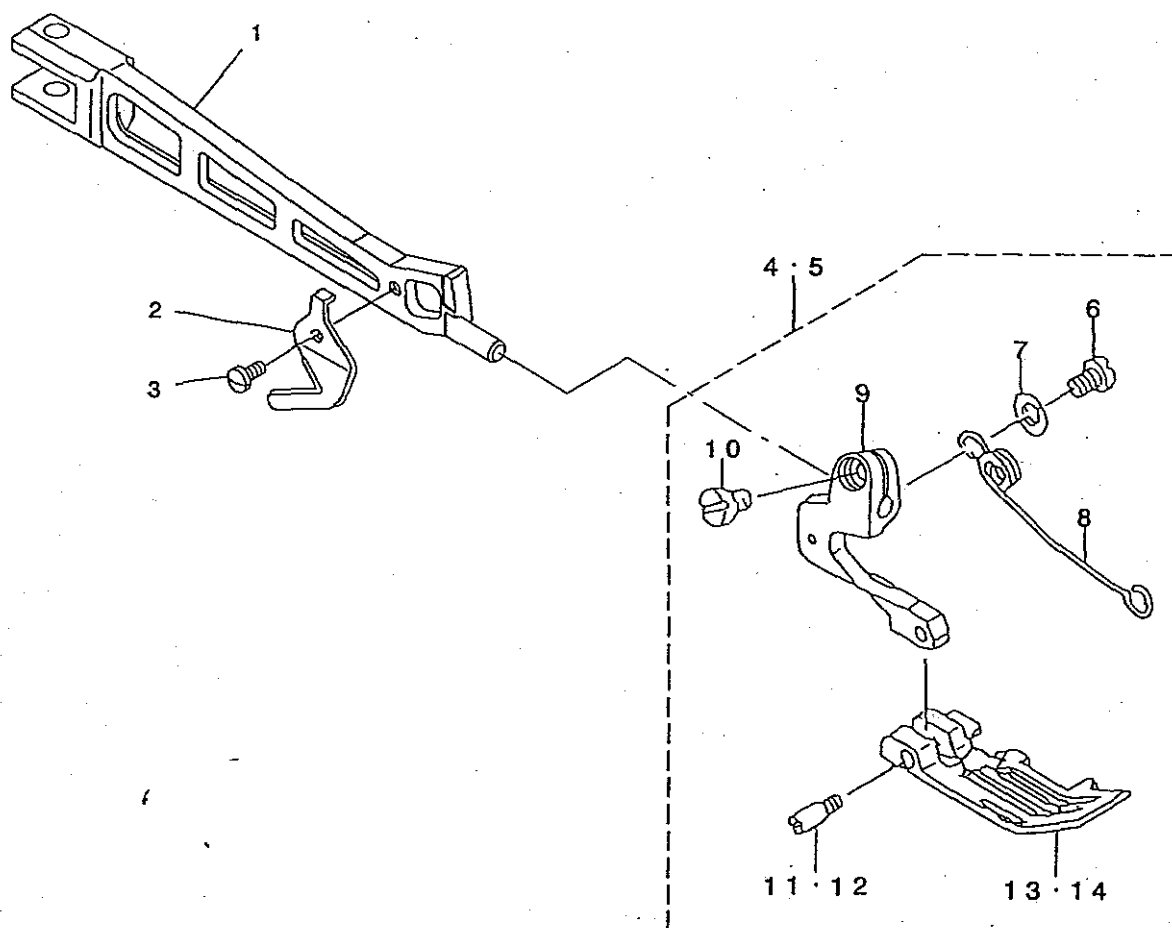

REF. NO	NOTE	PART NO.	DESCRIPTION	ヒョウメイ	Qty
1		123-05603	PRESSER ARM	オサエウデ	1
2		B1528-804-000-A	THREAD TRIMMER	イトキリハ	1
3		SS-7060510-SP	SCREW 3/32-56 L=4.8	マルヒラネツ 3/32-56 L=4.8	1
4	#01	119-32068	PRESSER FOOT ASM.	オサエクミ	1
5	#02	119-32456	PRESSER FOOT ASM.	オサエクミ	1
6		SS-7080520-SP	SCREW 1/8-44 L=4.9	マルヒラネツ 1/8-44 L=4.9	(1)
7		WP-0371026-SD	WASHER 3.7X7X1	ヒラサガネ 3.7X7X1	(1)
8		119-30906	PRESSER FOOT SPRING	オサエセンハネ	(1)
9		119-25104	PRESSER FOOT HINGE	オサエヒンツ	(1)
10		SS-6090650-SP	SCREW 9/64-40 L=6	ヒラネツ 9/64-40 L=6	(1)
11	#01	119-30500	PRESSER FOOT HINGE PIN	オサエヒンツ シク	(1)
12	#02	119-30609	HINGE PIN	オサエヒンツ シク	(1)
13	#01	119-25914	PRESSER	オサエ	(1)
14	#02	119-26300	PRESSER FOOT	オサエ	(1)
NOTE (注記)			#01....FOR SP161S400M032	SP161S400M032用	
			#02....FOR SP172S400MACC	SP172S400MACC用	

12. THREAD TENSION COMPONENTS

糸調子関係

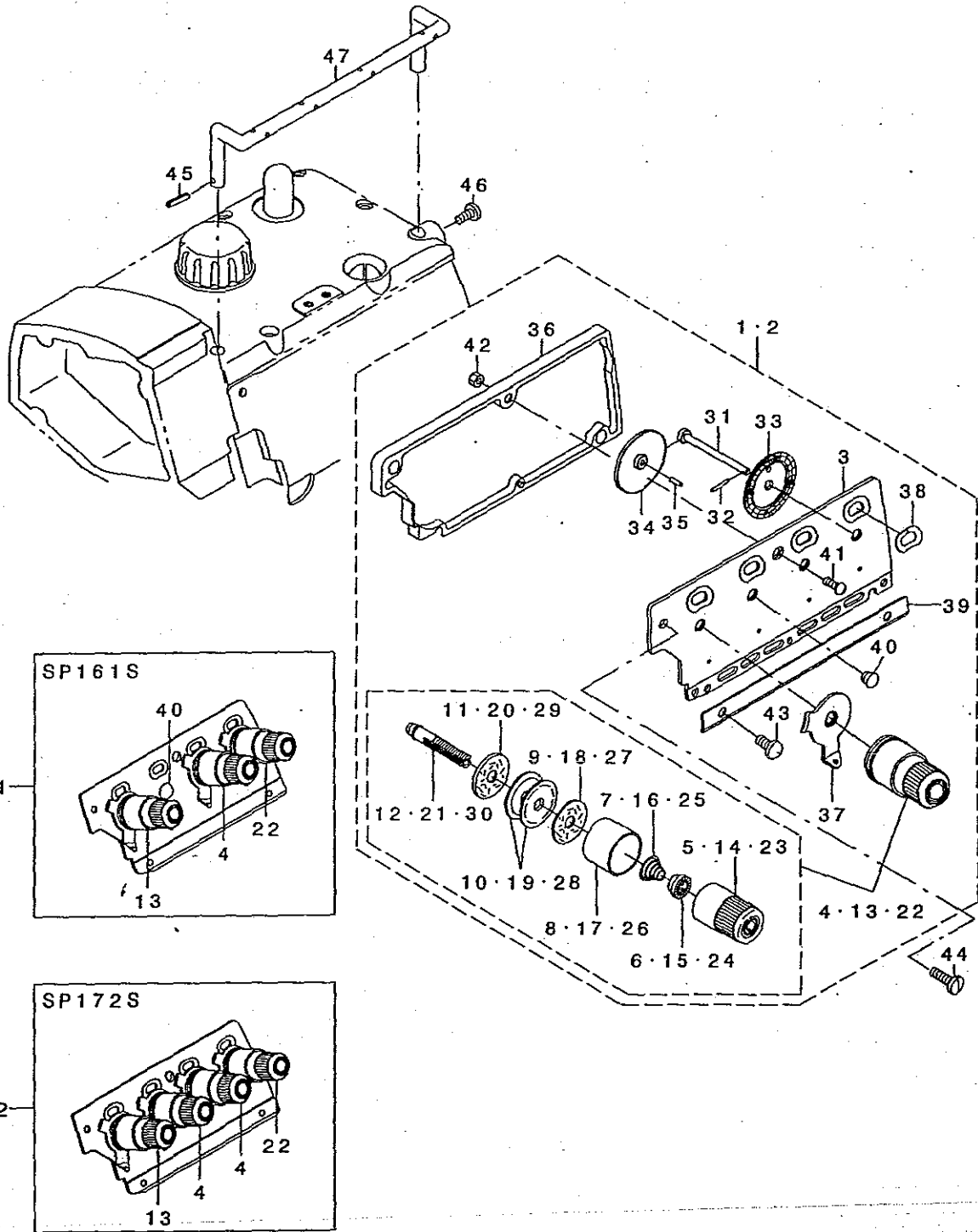

REF. NO	NOTE	PART NO.	DESCRIPTION	品名	Qty
1	#01	121-80162	THREAD GUIDE PLATE ASM.	トアンナイハシクミ	1
2	#02	121-80261	THREAD GUIDE PLATE ASM.	トアンナイハシクミ	1
3		121-26207	THREAD GUIDE PLATE	トアンナイハシ	(1)
4		121-26967	KNOB ASM. ,YELLOW	トチヨウツツマミ キクミ	(1)
5		121-26918	KNOB ,YELLOW	トチヨウツツマミ キ	(1)
6		B3112-704-000	TENSION SPRING BUSHING	ハネ アツシユ	(1)
7		B3102-804-000	TENSION SPRING, YELLOW	トチヨウツツマミ ハネ (キロ)	(1)
8		121-26702	TENSION DISK PRESSER	チヨウツツマミ ラ オサエ	(1)
9		B3120-704-000	THREAD TENSION SPRING FELT	トチヨウツツマミ ハネサ フェルト	(1)
10		B3126-012-000	THREAD TENSION DISK	トチヨウツツマミ	(2)
11		B3120-352-000	THREAD TENSION SPRING FELT	トチヨウツツマミ ハネサ フェルト	(1)
12		121-26405	THREAD TENSION BAR	トチヨウツツマミ ホウ	(1)
13		121-26868	KNOB ASM. ,RED	トチヨウツツマミ アカクミ	(1)
14		121-26819	KNOB ,RED	トチヨウツツマミ アカ	(1)
15		B3112-704-000	TENSION SPRING BUSHING	ハネ アツシユ	(1)
16		B3101-804-000	TENSION SPRING, RED	トチヨウツツマミ ハネ	(1)
17		121-26702	TENSION DISK PRESSER	チヨウツツマミ ラ オサエ	(1)
18		B3120-704-000	THREAD TENSION SPRING FELT	トチヨウツツマミ ハネサ フェルト	(1)
19		B3126-012-000	THREAD TENSION DISK	トチヨウツツマミ	(2)
20		B3120-352-000	THREAD TENSION SPRING FELT	トチヨウツツマミ ハネサ フェルト	(1)
21		121-26405	THREAD TENSION BAR	トチヨウツツマミ ホウ	(1)
22		121-27064	KNOB ASM. ,BLUE	トチヨウツツマミ アオクミ	(1)
23		121-27015	KNOB ,BLUE	トチヨウツツマミ アオ	(1)
24		B3112-704-000	TENSION SPRING BUSHING	ハネ アツシユ	(1)
25		B3103-804-000	TENSION SPRING, BLUE	トチヨウツツマミ ハネ (アオ)	(1)
26		121-26702	TENSION DISK PRESSER	チヨウツツマミ ラ オサエ	(1)
27		B3120-704-000	THREAD TENSION SPRING FELT	トチヨウツツマミ ハネサ フェルト	(1)
28		B3126-012-000	THREAD TENSION DISK	トチヨウツツマミ	(2)
29		B3120-352-000	THREAD TENSION SPRING FELT	トチヨウツツマミ ハネサ フェルト	(1)
30		121-26405	THREAD TENSION BAR	トチヨウツツマミ ホウ	(1)
31		121-27403	SCALE SHAFT	メモリアク	(1)
32		121-27502	SCALE SHAFT PIN	メモリアクピン	(1)
33		121-27601	SCALE GEAR	メモリアクギヤ	(1)
34		121-27700	GEAR	ニダンハクギヤ	(1)
35		121-27809	GEAR SHAFT	ハクギヤク	(1)
36		121-27957	SCALE CASE ASM.	メモリアクケース	(1)
37		121-26504	NEEDLE THREAD GUIDE	ハリトチヨウツツマミ サライトアンナイ	(1)
38		121-28203	SCALE SIDE PLATE	メモリアクサイド	(1)
39		121-28302	THREAD LOOPER GUIDE	ループトチヨウツツマミ	(1)
40	#01	TA-0620504-R0	CAP	トメシ	(1)
41		SS-2090830-SL	SCREW	マルチラネジ	(1)
42		NS-6090310-SP	NUT 9/64-40	ロツカクナツト 9/64-40	(1)
43		SS-7110740-TL	SCREW 11/64-40 L= 7.0	マルチラネジ 11/64-40 L=7	(1)
44		SM-4041455-SN	SCREW M4 L=14	チハネジ M4 L=14	2
45		PS-0300132-KH	SPRING PIN 3X13	スプリングピン	1
46		SS-7110910-TP	SCREW 11/64-40 L= 8.5	マルチラネジ 11/64-40 L=8.5	1
47		121-26108	CENTER THREAD GUIDE	チュウカン トアンナイ	1

NOTE (注記)

#01....FOR SP161S400M032
#02....FOR SP172S400MACC

SP161S400M032用
SP172S400MACC用

13. LOWER KNIFE COMPONENTS

下メス関係

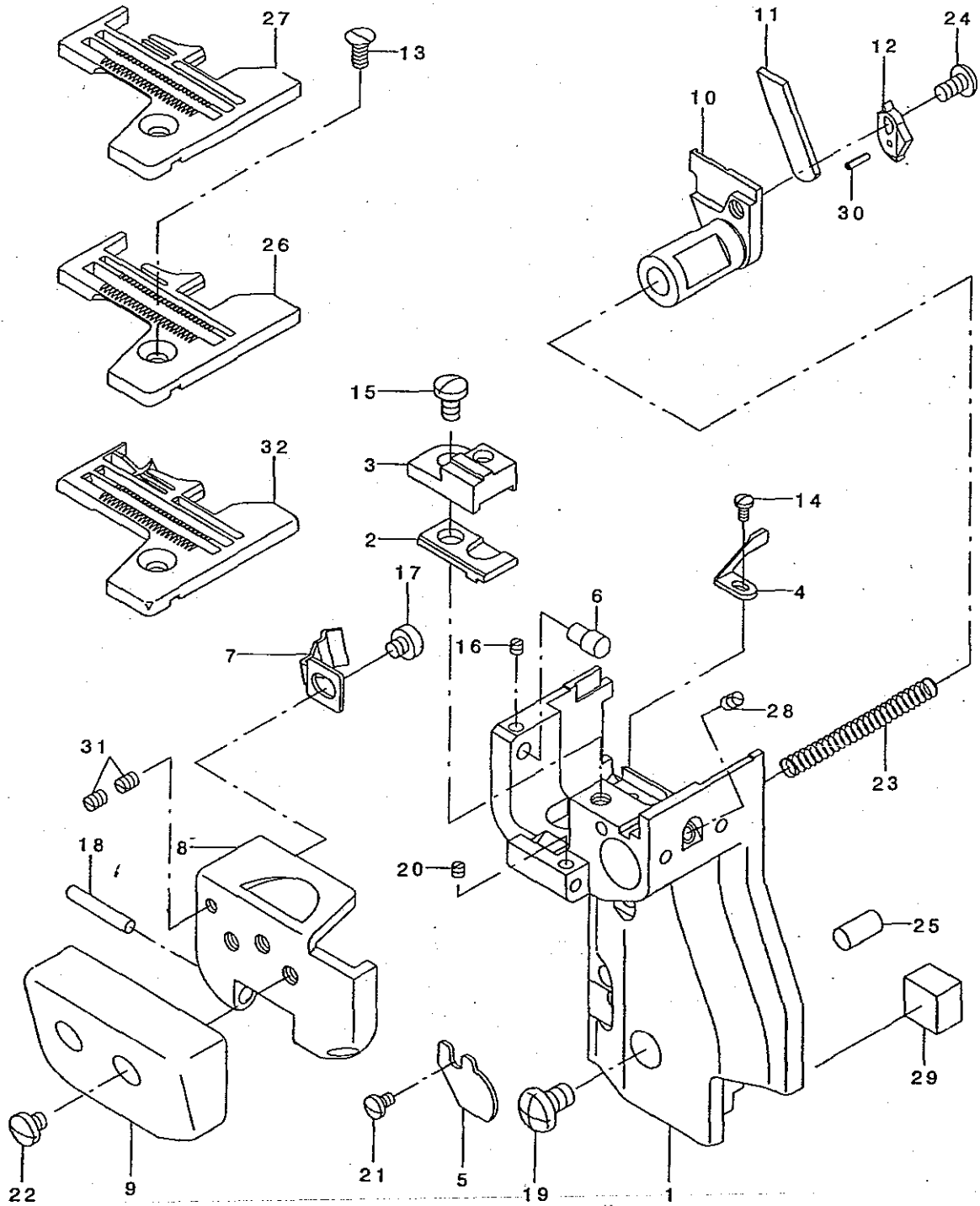

REF. NO	NOTE	PART NO.	DESCRIPTION	ヒ ヲ メ イ	Qty
1		122-19101	CYLINDER BRACKET	シリンダ - フ ラケツト	1
2		122-19903	THROAT PLATE BASE, LOWER	ハリタダ イ ヲタ	1
3		122-19804	THROAT PLATE BASE, UPPER	ハリタ ダ イウエ	1
4		122-40701	NEEDLE GUARD	ハリウケ	1
5		122-20109	SPRING STOPPER	シタメスハ ネ トメイタ	1
6		122-19606	PIN	シリンダ - カハ - トメビ ヲン	1
7		122-19507	SPRING	シリンダ - カハ - ハ ネ	1
8		122-19200	COVER BASE	シリンダ - カハ - タ イ	1
9		122-19358	CYLINDER COVER ASM.	シリンダ - カハ - クミ	1
10		122-20000	LOWER KNIFE SLIDE STUD	シタメス スライ ト シ ャク	1
11		122-20307	LOWER KNIFE	シタメス	1
12		122-20208	LOWER KNIFE PRESSER PRATE	シタメス オサエ	1
13		SS-2110910-SL	SCREW 11/64-40 L=9	マルサヲネシ ャク 11/64-40 L=8.5	1
14		SS-7060510-SP	SCREW 3/32-56 L=4.8	マルヒヲネシ ャク 3/32-56 L=4.8	1
15		SS-7110840-SP	SCREW 11/64-40 L=7.8	マルヒヲネシ ャク 11/64-40 L=7.8	1
16		SS-8080310-TP	SCREW 1/8-44 L=2.8	トメネシ ャク 1/8-44 L=2.8	1
17		SS-6110480-SP	SCREW 11/64-40 L=4.3	ヒヲネシ ャク 11/64-40 L=4.3	1
18		111-11705	WIPER SOLENOID PIN	ワイハ - ソレノイ ド シ ャク	1
19		SM-4050855-SP	SCREW M5 L=8	ナハ ネシ ャク M5 L=8	3
20		SS-8080310-TP	SCREW 1/8-44 L=2.8	トメネシ ャク 1/8-44 L=2.8	1
21		SS-7080520-SP	SCREW 1/8-44 L=4.9	マルヒヲネシ ャク 1/8-44 L=4.9	1
22		SS-7110510-SP	SCREW 11/64-40 L=5	マルヒヲネシ ャク 11/64-40 L= 5	2
23		122-20505	SPRING	シタメス スライ ト シ ャク ハ ネ	1
24		SS-4110815-SP	SCREW 11/64-40 L=8	ナハ ネシ ャク 11/64-40 L=8	1
25		122-19705	PIN	フ ラケツト コテイビ ヲン	2
26	#01	R4200-KOD-D00	THROAT PLATE	ハリタ	1
27	#02	R4305-KOD-E00	THROAT PLATE	ハリタ	1
28		SS-8110422-TP	SCREW 11/64-40 L=4	トメネシ ャク 11/64-40 L=4	1
29		122-20604	BRACKET	フ ラケツト セン	1
30		PS-0150065-KP	SPRING PIN 1.5X6	ス プ リング ビ ヲン 1.5X6	1
31		SS-8080410-TP	SCREW 1/8-44 L=3.5	トメネシ ャク 1/8-44 L=3.5	2
32	#03	R4305-KOD-E0A	THROAT PLATE	ハリタ	1

NOTE (注記)

#01....FOR SP161S400M032
 #02....FOR SP172S400MACC
 #03....P04/Q01 EXCHANGING PARTS

SP161S400M032用
 SP172S400MACC用
 P04/Q01交換部品

14. UPPER KNIFE COMPONENTS

上メス関係

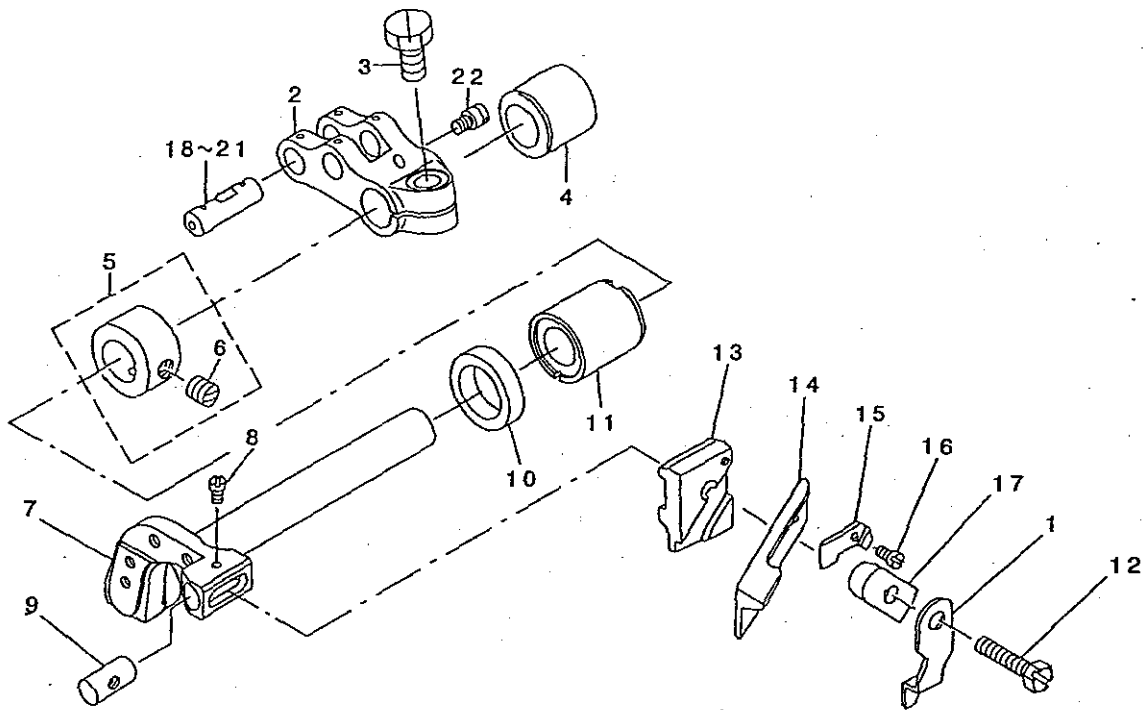

REF. NO	NOTE	PART NO.	DESCRIPTION	とんめい	Qty
1		118-48405	UPPER KNIFE COVER	ウツメスカハ	1
2		123-18002	UPPER KNIFE BRANCH ARM	ウツメスフタマタウデ	1
3		SM-9061250-TP	SCREW M6 L=12	ロツカクネ ねト M6 L=12	1
4		121-32502	BUSHING, REAR	ウエメスツク ウツロメタル	1
5		CS-111101H-SH	THRUST COLLAR ASM.	ツ ヨウケ ツ クスラストカラ-(クミ)	1
6		SS-8660330-SP	SCREW 1/4-40 L=3.0	トメネツ 1/4-40 L=3	(1)
7		123-18101	KNIFE ARM SHAFT	メスウデ ツク	1
8		SS-4060310-SP	SCREW 3/32-56 L=2.5	ナハ ネツ 3/32-56 L=2.5	1
9		115-65801	UPPER KNIFE GUIDE SHAFT	ウツメスカ イト ツク	1
10		115-66809	OIL SEAL	ウツメスツク オイルシール	1
11		123-09803	VERTICAL SHAFT FRONT METAL	ツ ヨウケ ツ クマエメタル	1
12		SS-9111610-SP	SCREW 11/64-40 L=16	ロツカクネ ねト 11/64-40 L=16	1
13		115-98000	UPPER KNIFE SUPPORT	ウツメスササエ	1
14		118-45807	UPPER KNIFE	ウツメス	1
15		115-65702	WASHER	ウツメスオサエ サカネ	1
16		SS-4060310-SP	SCREW 3/32-56 L=2.5	ナハ ネツ 3/32-56 L=2.5	1
17		115-65504	UPPER KNIFE PRESSER PLATE	ウツメスオサエ	1
18	#01	118-23804	CRANK PIN C	オクリフタマタ クランクピン C	1
19	#01	118-23606	CRANK PIN A	オクリフタマタ クランクピン A	1
20	#01	118-23705	CRANK PIN B	オクリフタマタ クランクピン B	1
21	#01	118-23903	CRANK PIN D	オクリフタマタ クランクピン D	1
22		B2024-771-000	SUSPENSION SCREW	ウツメスツク ハネカケ	1

NOTE (注記) #01....SELECTING PART FOR FIT TOLERANCE 選択かん合部品

15. NEEDLE COOLING MECHANISM COMPONENTS

針冷却装置関係

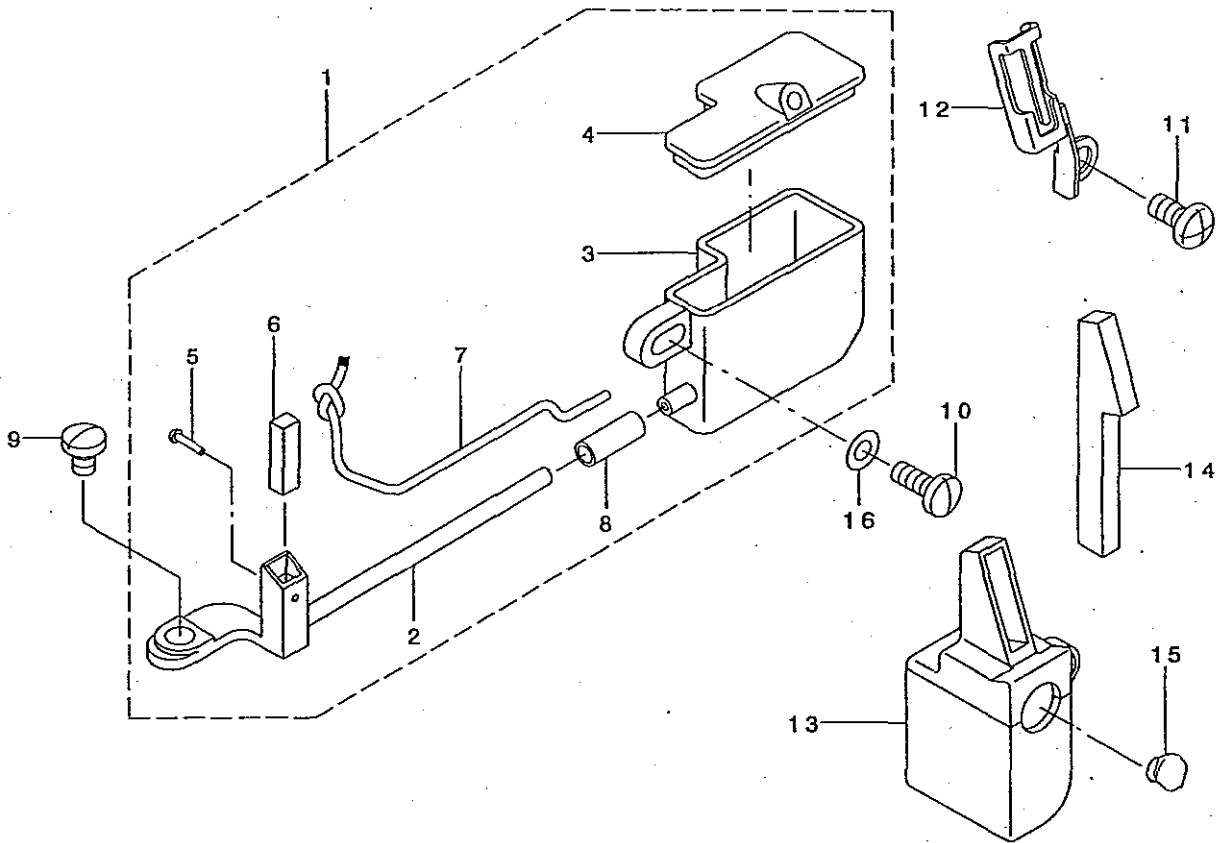

REF. NO	NOTE	PART NO.	DESCRIPTION	ヒソメイ	Qty
1		122-24655	NEEDLE COOLER TANK ASM.	ハリレイキヤクタンク クミ	1
2		122-24853	NEEDLE COOLER ASM.	ハリレイキヤクキツゴウ	(1)
3		122-24606	TANK	ハリレイキヤクタンク	(1)
4		122-24705	TANK COVER	ハリレイキヤクタンクフタ	(1)
5		118-56101	NEEDLE COOLER PIN	ハリレイキヤクフェルトピン	(1)
6		122-25009	FELT	ハリレイキヤクフェルト	(1)
7		CQ-2000000-00	OIL WICK	ユツン	(0.15)
8		BT-0400251-ED	TUBE HOSE, GREEN	ウレタンホース ミドリ	(0.01)
9		SS-7090540-TP	SCREW 9/64-40 L=5	マルヒラネツ 9/64-40 L=5	1
10		SS-7090910-SP	SCREW 9/64-40 L= 8.5	マルヒラネツ 9/64-40 L=8.5	1
11		SM-4040855-SP	SCREW	ナハネツ	1
12		121-38400	PRESSER	ハリイトフェルトオサエ	1
13		121-38152	SILICON TANK ASM.	ハリイトタンククミ	1
14		121-38301	FELT	ハリイトフェルト	1
15		TA-0950806-R0	RUBBER PLUG	トメセン	1
16		WP-0371026-SD	WASHER 3.7X7X1	ヒラサガネ 3.7X7X1	1

16. LUBRICATION MECHANISM COMPONENTS

給油装置関係

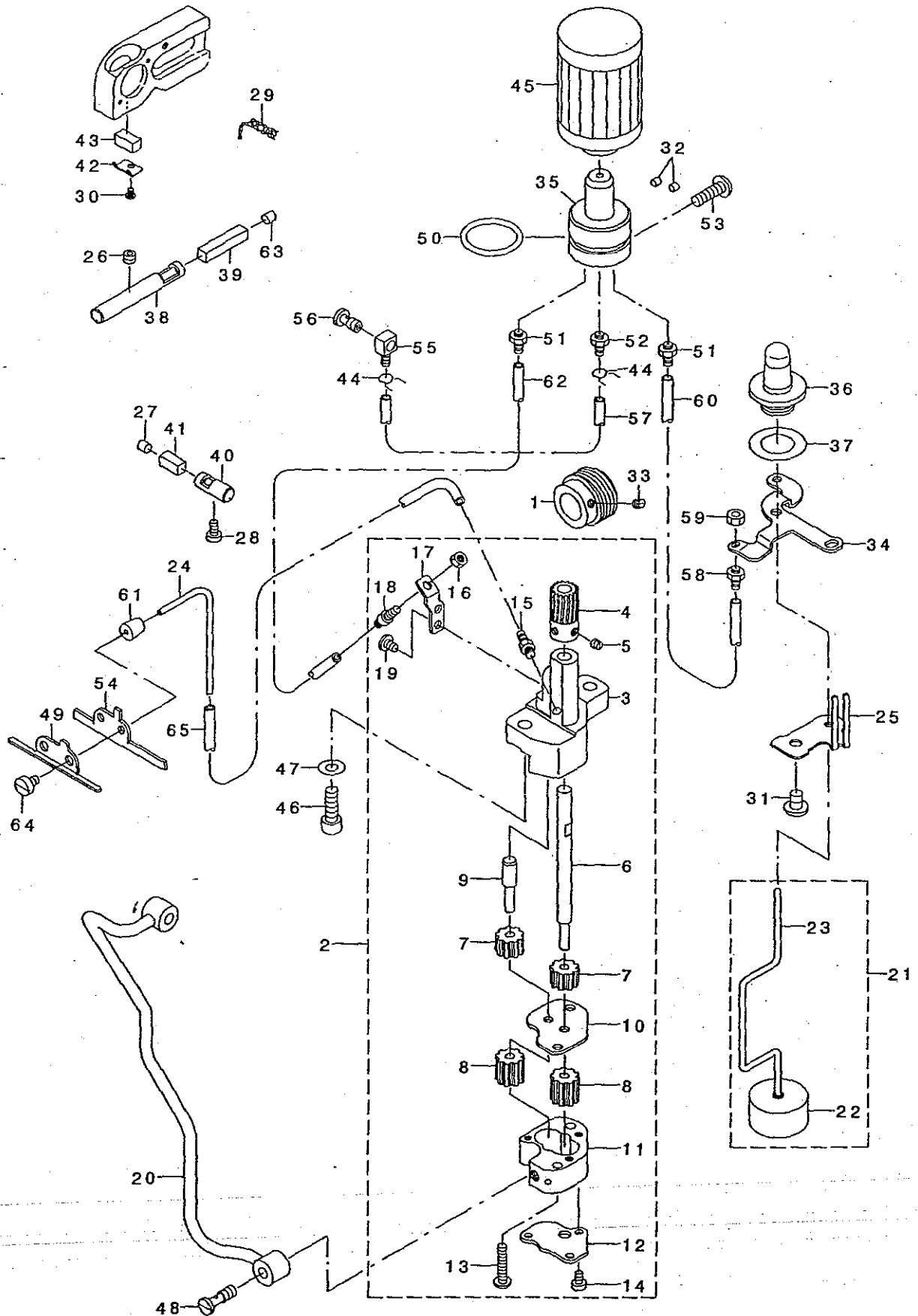

REF. NO	NOTE	PART NO.	DESCRIPTION	ヒョウメイ	Qty
1		123-15008	WORM	ウオ-1	1
2		122-93957	LUBRICATING PUMP BODY ASM.	キウユホ' ヲ' タイクツコ' ウ	1
3		123-15909	LUBRICATING PUMP BODY	キウユホ' ヲ' タイ	(1)
4		118-41707	WORM GEAR	ウオ-1ハク' ルマ	(1)
5		SS-8110410-TP	SCREW 11/64-40 L= 3.5	トメネジ' 11/64-40 L=3.5	(2)
6		119-18109	GEAR PUMP SHAFT LARGE	キ' キホ' ヲ' シ' ク' タイ	(1)
7		B3534-352-000	PINION GEAR	ピ' ニオン	(2)
8		118-40303	OIL PUMP PINION	ホ' ヲ' ヨウ' ビ' ニオン	(2)
9		123-17004	GEAR PUMP SHAFT	キ' キホ' ヲ' シ' ク' (ヨウ)	(1)
10		123-16006	PINION SPACER	ピ' ニオン' ス' -チ	(1)
11		123-16105	CASING	ケ-ランク	(1)
12		123-16204	COVER	ホ' ヲ' ヲ' ツ' フ' タ	(1)
13		SS-4112215-SP	SCREW 11/64-40 L=22	ナ' ベ' ネジ' 11/64-40 L=22	(2)
14		SS-6090650-SP	SCREW 9/64-40 L=6	ヒラネジ' 9/64-40 L=6	(3)
15		SQ-1110401-MZ	CONNECTING SCREW	チュ-ブ' レンケツネジ'	(1)
16		NS-6110310-SP	NUT 11/64-40	ロツカクナツト' 11/64-40	(1)
17		121-29318	CONNECTING SCREW BRACKET	ウオ-1ト' ヲ' ヲ' ク' チ' チ' エ	(1)
18		SQ-1110451-MZ	CONNECTING SCREW	ハ' イ' レンケツネジ'	(1)
19		SS-4110615-SP	SCREW 11/64-40 L=6	ナ' ベ' コネジ' 11/64-40 L=6	(2)
20		122-93551	LUBRICATING PIPE ASM.	キウユホ' イ' ク' ミ	1
21		122-93759	FLOAT ASM.	ウキコ' ク' ミ	1
22		121-29805	FLOAT	ウキコ	(1)
23		122-93700	OIL QUANTITY INDICATION BAR	ア' フ' ラ' リ' ヨ' ウ' ツ' ホ' ウ	(1)
24		122-93601	ONCE THROUGH OIL PIPE	ウツオクリ' カ' リ' ヨ' ウ' ハ' イ' ア'	1
25		122-93809	FLOAT SUPPORT	ウキコ' チ' チ' エ	1
26		SM-8050402-TP	SCREW	トメネジ'	1
27		TA-0400301-MO	PLUG D=4X4.5 L=3	トメセン D=4X4.5 L=3	1
28		SS-6121020-SP	SCREW 3/16-28 L= 9.5	ヒラネジ' 3/16-28 L=9.5	1
29		CQ-2020000-00	OIL WICK	ユツシ	0.06
30		SS-7060310-SP	SCREW 3/32-56 L=3	マ' ル' ヒラネジ' 3/32-56 L=3	1
31		SM-4060801-SE	SCREW	ナ' ベ' ネジ'	1
32		TA-0290301-MO	PLUG 2.9X3.2X3	トメセン D=2.9X3.2 L=3	2
33		SS-8110520-TP	SCREW 11/64-40 L= 4.5	トメネジ' 11/64-40 L=4.5	1
34		123-15800	OILING EXIT SUPPORT	ハ' キ' タ' シ' ク' チ' チ' エ	1
35		121-29706	FILTER GUIDE	フィルタ-ガ' イ' ト'	1
36		121-30100	OIL GAUGE	オイルゲ-ジ'	1
37		121-30209	RUBBER PACKING	オイルゲ-ジ' ハ' ヲ' ヲ' キン	1
38		121-30308	OILING PIN	ハリ' キウユホ' ビ' ヲ' シ	1
39		121-30407	OIL FELT	ハリ' キウユホ' ビ' ヲ' シ' フェルト	1
40		121-30506	OILING PIN	ウエル-ハ' -キウユホ' ビ' ヲ' シ	1
41		121-30605	OIL FELT	ウエル-ハ' -キウユホ' ビ' ヲ' シ' フェルト	1
42		121-30704	FELT HOLDER	ウエル-ハ' -キウユホ' フェルト' オ' チ' エ	1
43		121-30803	OIL FELT	ウエル-ハ' -キウユホ' フェルト	1
44		101-26803	OIL TUBE HOLDER	ハ' イ' ト' メ	2
45		118-43208	CARTRIDGE FILTER	カートリッヅ' フィルタ-	1
46		SM-6061802-TP	SCREW M6 L=18	ロツカクナツト' M6' ル' ト'	2
47		WP-0651056-SD	WASHER 6.5X11X1	ヒラシ' ガ' ネ' 6.5X11X1	2
48		SQ-1150454-SD	CONNECTING SCREW	ハ' イ' レンケツネジ'	2
49		123-15503	ONCE THROUGH OIL FELT PRESSER	カ' リ' ヨ' ウ' フェルト' オ' チ' エ	1
50		RO-2182401-00	RUBBER RING	ロツク'	1
51		SQ-1110451-MZ	CONNECTING SCREW	ハ' イ' レンケツネジ'	2
52		SQ-1150451-MZ	CONNECTING SCREW	チュ-ブ' レンケツネジ'	1
53		SM-4051601-SC	SCREW M5X0.8 L=16	ナ' ベ' コネジ' M5X0.8 L=16	1
54		123-15602	ONCE THROUGH OIL FELT	ウツオクリ' カ' リ' ヨ' ウ' フェルト	1
55		SQ-0000451-MZ	CONNECTING SCREW	ハ' イ' レンケツネジ'	1
56		SQ-1150441-SD	CONNECTING SCREW	ハ' イ' レンケツネジ'	1
57		BT-0500300-EA	OIL TUBE	ウレタン' チュ-ブ'	0.22
58		SQ-1110451-MZ	CONNECTING SCREW	ハ' イ' レンケツネジ'	1
59		NS-6110310-SP	NUT 11/64-40	ロツカクナツト' 11/64-40	1
60		BT-0500300-EA	OIL TUBE	ウレタン' チュ-ブ'	0.14
61		118-15107	OIL WICK COVER BUSHING	ユツシ' ガ' ハ' - ア' ヲ' ツ' ヌ	1
62		BT-0500300-EG	OIL TUBE	チュ-ブ'	0.25
63		TA-0400301-MO	PLUG D=4X4.5 L=3	トメセン D=4X4.5 L=3	1
64		SS-6120620-TP	SCREW	ヒラ' ネジ'	2
65		BT-0500300-EG	OIL TUBE	チュ-ブ'	0.25

17. THREAD STAND COMPONENTS

糸立装置関係

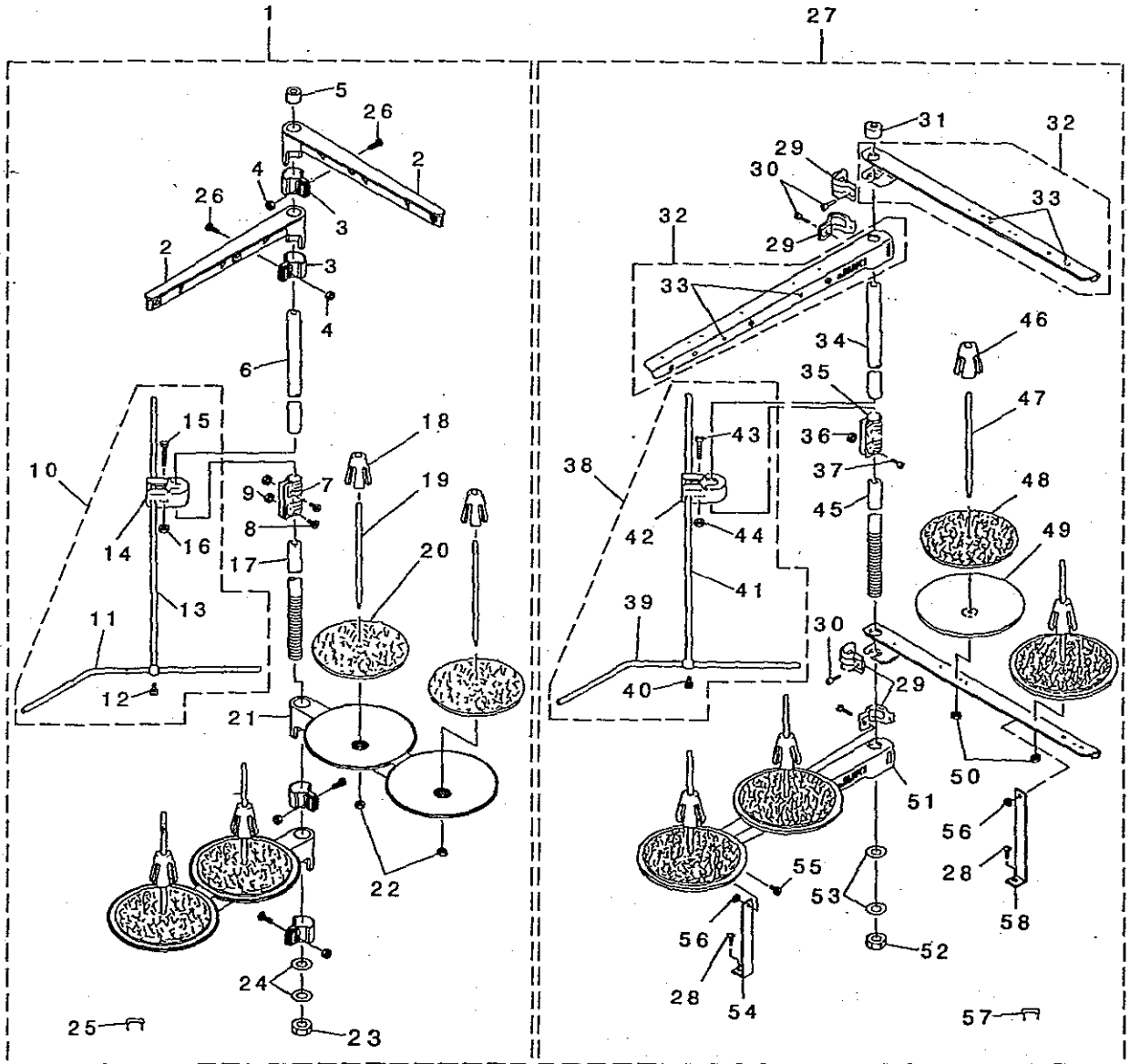

REF. NO	NOTE	PART NO.	DESCRIPTION	品名	Qty
1		119-69458	THREAD STANDING DEVICE ASM.	イトテソウチ クミ	1
2		111-85352	THREAD GUIDE ASM.	イトテイトアンナイ クミ	(2)
3		111-85402	THREAD GUIDE ARM JOINT	イトテウデ シメカナク	(4)
4		NW-6050001-SE	NUT M5X0.8	ロツカクナツト M5X0.8 17ユ	(4)
5		B3311-704-000	SPOOL REST ROD RUBBER CAP	イトテホ - ネゴ コ A	(1)
6		111-85204	SPOOL REST ROD, UPPER	イトテホ ウウエ	(1)
7		B3305-704-000-A	SPOOL REST ROD JOINT	イトテホ - ヅキ テ	(1)
8		SM-4051405-SE	SCREW M5X0.8 L=14	ナハ コネジ M5X0.8 L=14	(2)
9		NW-6050001-SE	NUT M5X0.8	ロツカクナツト M5X0.8 17ユ	(2)
10		B3309-704-0A0	THREAD GUIDE ARM ASM.	イトテ イトアンナイ ウデ クミ	(1)
11		B3311-804-000	LOWER THREAD GUIDE	イトテ イトアンナイ ッタ	(1)
12		SS-7110540-SP	SCREW 11/64-40 L=5	マルヒラネジ 11/64-40 L=5	(1)
13		B3309-704-000	THREAD GUIDE ARM	イトテ イトアンナイ ウデ	(1)
14		B3304-704-000-A	THREAD GUIDE ARM HOLDER	イトアンナイウデ ネルダ -	(1)
15		SM-6053000-SE	SCREW M5X0.8 L=30	ヒラコネジ M5X0.8 30	(1)
16		NW-6050001-SE	NUT M5X0.8	ロツカクナツト M5X0.8 17ユ	(1)
17		111-85105	SPOOL REST ROD, LOWER	イトテホ ウウタ	(1)
18		111-85501	SPOOL RETAINER	イトマキ フルトメ	(4)
19		B3320-704-L00-A	SPOOL PIN	イトマキウケホ ウ	(4)
20		B3311-012-000	SPOOL REST CUSHION	イトマキウケサ	(4)
21		111-85006	THREAD STAND ARM.	イトテウデ	(2)
22		NW-6050001-SE	NUT M5X0.8	ロツカクナツト M5X0.8 17ユ	(4)
23		B3317-704-000	NUT C15	イトテホ - トメナツト	(1)
24		WP-1612616-SE	WASHER 16X30X2.6	ヒラサ カネ 16X30X2.6	(2)
25		MAO-11532000	CORD STAPLE	コト ステツパル	(3)
26		SM-4051405-SE	SCREW M5X0.8 L=14	ナハ コネジ M5X0.8 L=14	(4)
27	#01	119-69953	THREAD STANDING DEVICE ASM.	イトテソウチ クミ	1
28		SK-3382001-SE	SCREW D=3.8 L=20	マルヒラネジ D=3.8 L=20	(2)
29		B3318-704-L00-A	THREAD GUIDE ARM JOINT	イトテウデ シメカナク	(4)
30		SM-6061610-SC	SCREW M6 L=16	ヒラコネジ M6 L=16	(4)
31		B3311-704-000	SPOOL REST ROD RUBBER CAP	イトテホ - ネゴ コ A	(1)
32		119-69573	SPOOL REST ARM A ASM.	イトテウデ A クミ	(2)
33		B3319-704-L00	THREAD GUIDE	イトミ	(4)
34		111-85204	SPOOL REST ROD, UPPER	イトテホ ウウエ	(1)
35		B3305-704-000-A	SPOOL REST ROD JOINT	イトテホ - ヅキ テ	(1)
36		NW-6050001-SE	NUT M5X0.8	ロツカクナツト M5X0.8 17ユ	(2)
37		SM-4051405-SE	SCREW M5X0.8 L=14	ナハ コネジ M5X0.8 L=14	(2)
38		B3309-704-0A0	THREAD GUIDE ARM ASM.	イトテ イトアンナイ ウデ クミ	(1)
39		B3311-804-000	LOWER THREAD GUIDE	イトテ イトアンナイ ッタ	(1)
40		SS-7110540-SP	SCREW 11/64-40 L=5	マルヒラネジ 11/64-40 L=5	(1)
41		B3309-704-000	THREAD GUIDE ARM	イトテ イトアンナイ ウデ	(1)
42		B3304-704-000-A	THREAD GUIDE ARM HOLDER	イトアンナイウデ ネルダ -	(1)
43		SM-6053000-SE	SCREW M5X0.8 L=30	ヒラコネジ M5X0.8 30	(1)
44		NW-6050001-SE	NUT M5X0.8	ロツカクナツト M5X0.8 17ユ	(2)
45		111-85105	SPOOL REST ROD, LOWER	イトテホ ウウタ	(1)
46		111-85501	SPOOL RETAINER	イトマキ フルトメ	(4)
47		B3320-704-L00-A	SPOOL PIN	イトマキウケホ ウ	(4)
48		B3311-012-000	SPOOL REST CUSHION	イトマキウケサ	(4)
49		119-66504	SPOOL REST	イトマキウケサ ラ	(4)
50		NW-6050001-SE	NUT M5X0.8	ロツカクナツト M5X0.8 17ユ	(4)
51		119-69508	SPOOL REST ARM A	イトテウデ A	(2)
52		B3317-704-000	NUT C15	イトテホ - トメナツト	(1)
53		WP-1612616-SE	WASHER 16X30X2.6	ヒラサ カネ	(2)
54		B3321-704-L00	SPOOL REST ARM SUPPORT, A	イトテウデ サチエ A	(1)
55		SM-4061201-SE	SCREW M6 L=12	ナハ コネジ M6 L=12	(2)
56		NW-6060001-SE	NUT M6	ロツカクナツト M6 17ユ	(2)
57		MAO-11532000	CORD STAPLE	コト ステツパル	(3)
58		B3321-704-LOB	SPOOL REST ARM SUPPORT, B	イトテウデ サチエ B	(1)

NOTE (注記)

#01....SPECIAL ORDER PART FOR LARGE SPOOL THREAD STAND (FOR EUROPE)

太巻用特別注文部品(ヨーロッパ用)

18. SEMI-SUNKEN TYPE TABLE COMPONENTS

卓上式テーブル関係

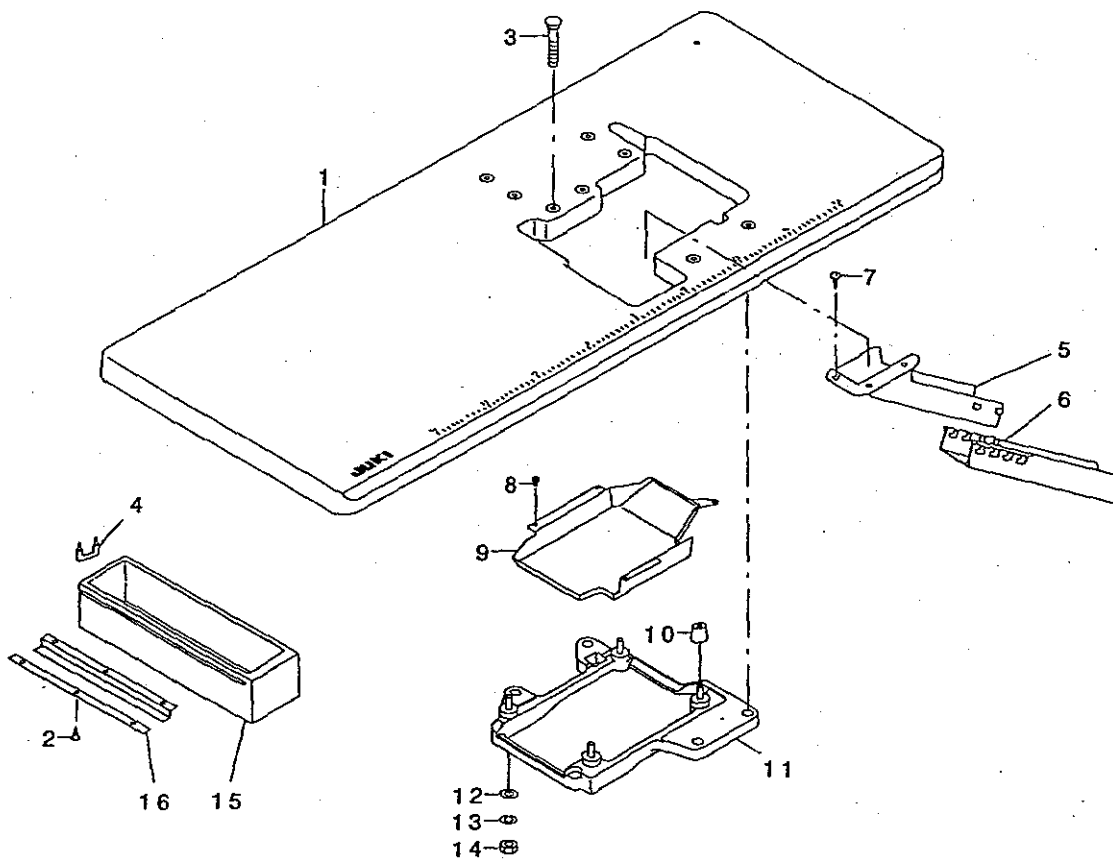

REF. NO	NOTE	PART NO.	DESCRIPTION	ヒヨメイ	Qty
1		122-21602	TABLE(SEMI-SUNKEN)	テーブル(タクトヨウツキ)	1
2		SK-3311500-SC	WOOD SCREW D=3.1 L=15	マルモクネツ D=3.1 L=15	6
3		115-71601	BOLT A	ウケイタネ A	4
4		D8204-555-D00	DRAWER STOPPER	ヒキダシストツパ	1
5		119-68609	CLOTH WASTE CHUTE (TABLE)	ヌノクス シュート ウエ (タクトヨウ)	1
6		119-60002	CLOTH WASTE CHUTE, LOWER(BENCH)	ヌノクス シュートウエ (タクトヨウ)	1
7		SK-2351600-SC	SCREW WASTE	マルサラモクネツ	3
8		S6-6090630-SP	SCREW 9/64-40 L=6	ヒラネツ 9/64-40 L=6	4
9		122-21800	COOLING FAN CASE	ツウフウ ケース	1
10		115-71403	RUBBER CUSHION	ホ-ションゴ A	4
11		122-21750	FRAME SUPPORT PLATE ASM.	フレームウケイタクミ	1
12		WP-1102016-SC	WASHER 11X21X2	ヒラサガネ 11X21X2	4
13		WS-1002560-KR	SPRING WASHER 10X18X2.5	ハネサガネ 10X18X2.5	4
14		NS-6240630-SN	NUT 3/8-18	ロツカクナツト 3/8-18	4
15		111-55108	DRAWER	ヒキダシ	1
16		111-55207	DRAWER SUPPORT	ヒキダシササエ	2

19. SPECIAL ORDER PARTS COMPONENTS

特別注文部品関係

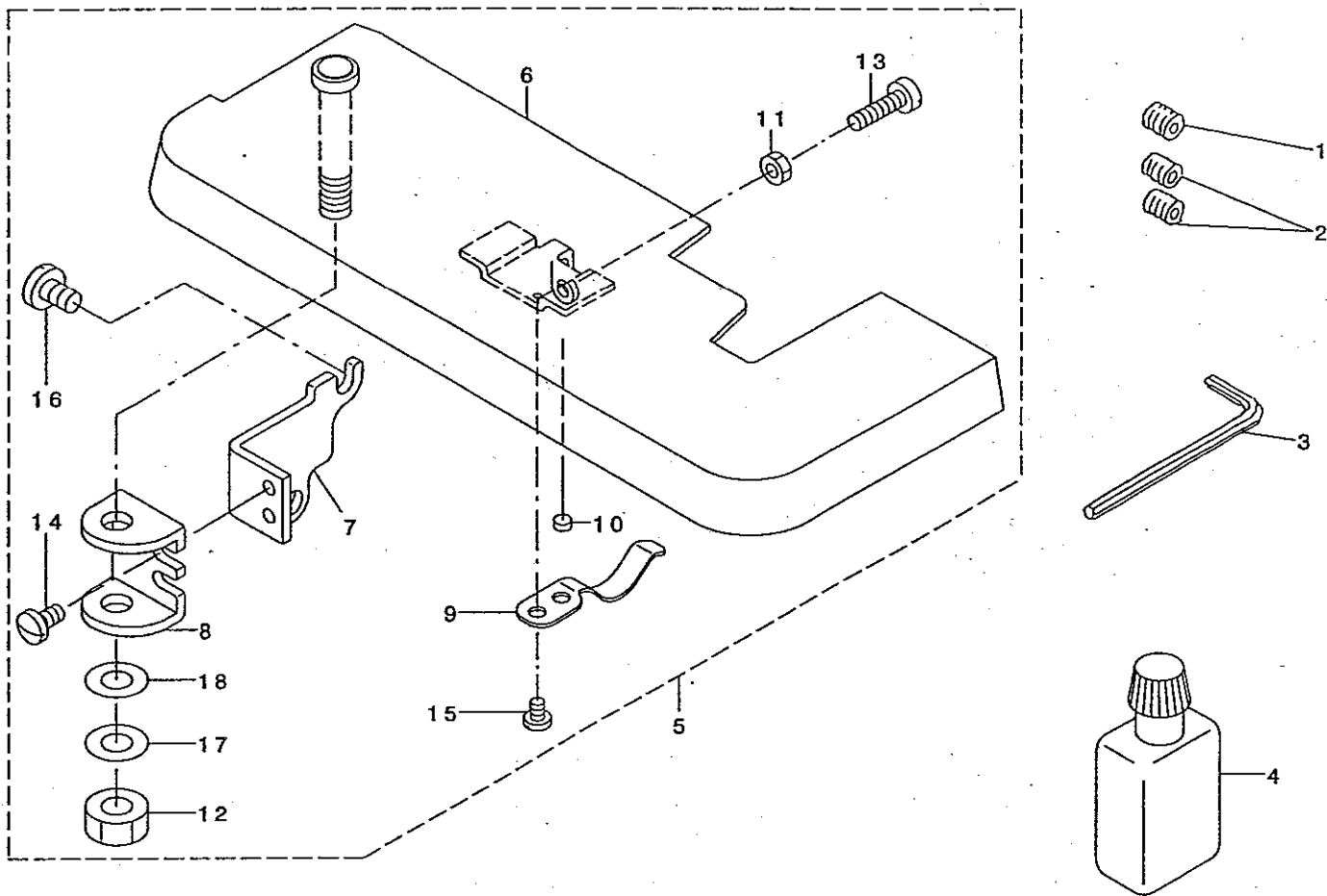

REF. NO	NOTE	PART NO.	DESCRIPTION	品名	Qty
1	#01	SS-8080322-TP	SCREW 1/8-44 L=3.2	トメネジ 1/8-44 L=3.2	1
2	#02	SS-8080322-TP	SCREW 1/8-44 L=3.2	トメネジ 1/8-44 L=3.2	2
3		B9112-804-000	SPANNER	ハリトメネジ スパナ	1
4		B9135-123-0B0	SILICON OIL LUBRICANT ASM. (30	エスレンヨ-キ (30CC)	1
5		122-26155	CLOTH BASE ASM.	ヌメアイクミ	1
6		122-26163	CLOTH BASE ASM.	ヌメアイクミ	(1)
7		122-26304	FITTING PLATE A	ヌメイトリツケイタ A	(1)
8		122-26403	FITTING PLATE B	ヌメイトリツケイタ B	(1)
9		122-26502	CLOTH BASE SPRING	ヌメイハネ	(1)
10		118-06304	PLUG	ハリイタタ	(1)
11		NS-6110310-SP	NUT 11/64-40	ロツカクナツト 11/64-40	(1)
12		NS-6680320-SP	NUT 9/32-28	ロツカクナツト 9/32-28	(2)
13		SS-6111610-SP	SCREW 11/64-40 L=16	ヒラネジ 11/64-40 L=16	(1)
14		SS-7110840-SP	SCREW 11/64-40 L=7.8	マルヒラネジ 11/64-40 L=7.8	(2)
15		SS-7090540-TP	SCREW 9/64-40 L=5	マルヒラネジ 9/64-40 L=5	(2)
16		SS-7150910-TP	SCREW	マルヒラネジ 15/64-28 L=9	(2)
17		WP-0841600-OE	WASHER 8.4X15.5X1.6	ヒラサガネ 8.4X15.5X1.6	(1)
18		WZ-0850302-KO	WAVED WASHER 8.5X12.5X0.3	ナミガタサガネ 8.5X12.5X0.3	(1)

NOTE (注記)

#01....FOR SP161S400M032

SP161S400M032用

#02....FOR SP172S400MACC

SP172S400MACC用

20.SUBCLASSES

サブクラス

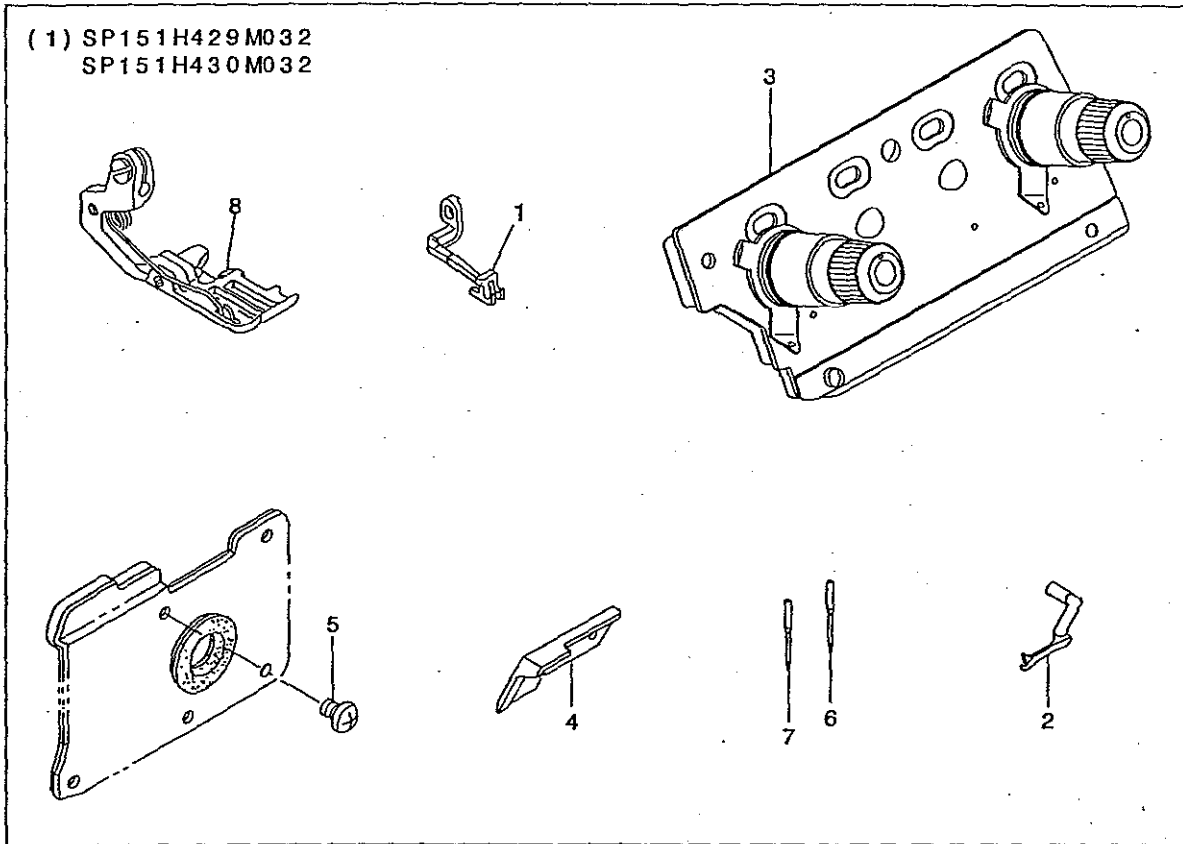

REF. NO	NOTE	PART NO.	DESCRIPTION	品名	Qty
1		119-39311	UPPER FEED DOG	ウツオクリハ	1
2		122-47508	UPPER LOOPER	ウエカキルーパー	1
3		121-80360	THREAD GUIDE PLATE ASM.	イトアンナイハシクミ	1
4		118-45906	UPPER KNIFE	ウツメス	1
5		SM-4040655-SP	SCREW	ナハコネジ M4 L=6	1
6		MDC-270B0900	NEEDLE DCX27 #9	ハリ DCX27 #9	1
7		NC-0336006-50	NEEDLE B-27 65	ハリ B-27 65	1
8		119-35764	PRESSER ASM.	オサエクミ	1

NOTE (注記)

*ALL PARTS NOT MENTIONED ABOVE ARE SAME AS THOSE OF SP161S400M032
上記以外の部品は、SP161S400M032と共通です。

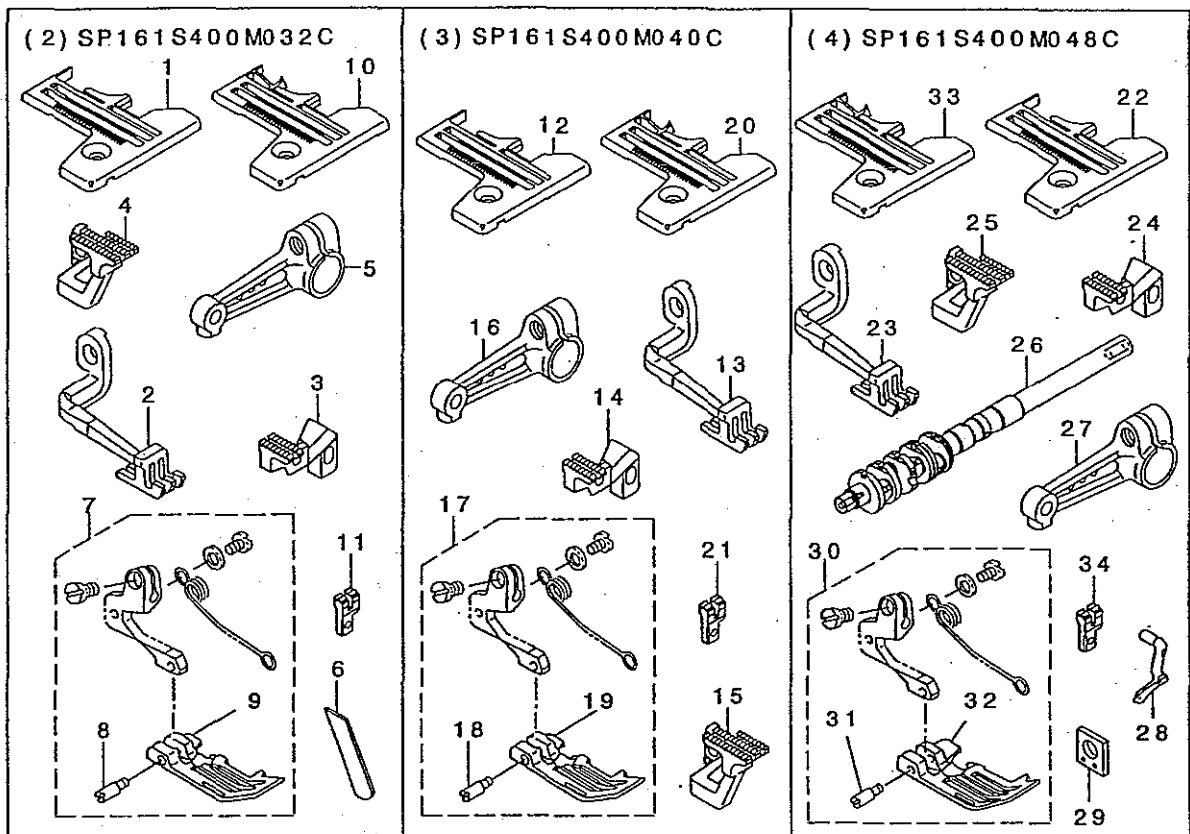

REF. NO	NOTE	PART NO.	DESCRIPTION	キ	リ	メ	イ	Qty
1		R4300-KOD-E00	THROAT PLATE	メ	イ			1
2		119-36804	TOP FEED DOG	リ				1
3		122-35206	MAIN FEED DOG	リ				1
4		122-36709	DIFFERENTIAL FEED DOG	リ				1
5		122-14607	UPPER LOOPER ARM D	メ				1
6		122-20406	LOWER KNIFE	メ				1
7		123-20453	PRESSER FOOT ASM.	メ				1
8		119-30609	HINGE PIN	メ				(1)
9		123-20404	PRESSER FOOT	メ				(1)
10	#01	R4300-KOD-E0A	THROAT PLATE	メ				1
11	#01	122-38200	AUXILIARY FEED DOG	メ				1
12		R4300-KOE-E00	THROAT PLATE	メ				1
13		119-36804	TOP FEED DOG	リ				1
14		122-35206	MAIN FEED DOG	リ				1
15		122-36709	DIFFERENTIAL FEED DOG	リ				1
16		122-14607	UPPER LOOPER ARM D	メ				1
17		123-20453	PRESSER FOOT ASM.	メ				1
18		119-30609	HINGE PIN	メ				(1)
19		123-20404	PRESSER FOOT	メ				(1)
20	#02	R4300-KOE-E0A	THROAT PLATE	メ				1
21	#02	122-38200	AUXILIARY FEED DOG	メ				1
22		R4300-KOF-E00	THROAT PLATE	メ				1
23		119-36804	TOP FEED DOG	リ				1
24		122-35206	MAIN FEED DOG	リ				1
25		122-36709	DIFFERENTIAL FEED DOG	リ				1
26		122-92108	MAIN SHAFT	メ				1
27		122-14607	UPPER LOOPER ARM D	メ				1
28		122-47102	UPPER LOOPER	メ				1
29		118-93609	GAUGE	メ				1
30		119-32258	PRESSER FOOT ASM.	メ				1
31		119-30609	HINGE PIN	メ				(1)
32		119-26102	PRESSER FOOT	メ				(1)
33	#03	R4300-KOF-E0A	THROAT PLATE	メ				1
34	#03	122-38200	AUXILIARY FEED DOG	メ				1

NOTE (注記)

#01...P01/Q01 EXCHANGING PARTS
 #02...P02/Q01 EXCHANGING PARTS
 #03...P03/Q01 EXCHANGING PARTS

P01/Q01交換部品
 P02/Q01交換部品
 P03/Q01交換部品

*ALL PARTS NOT MENTIONED ABOVE ARE SAME AS THOSE OF SP161S400M032
 上記以外の部品は、SP161S400M032と共通です。

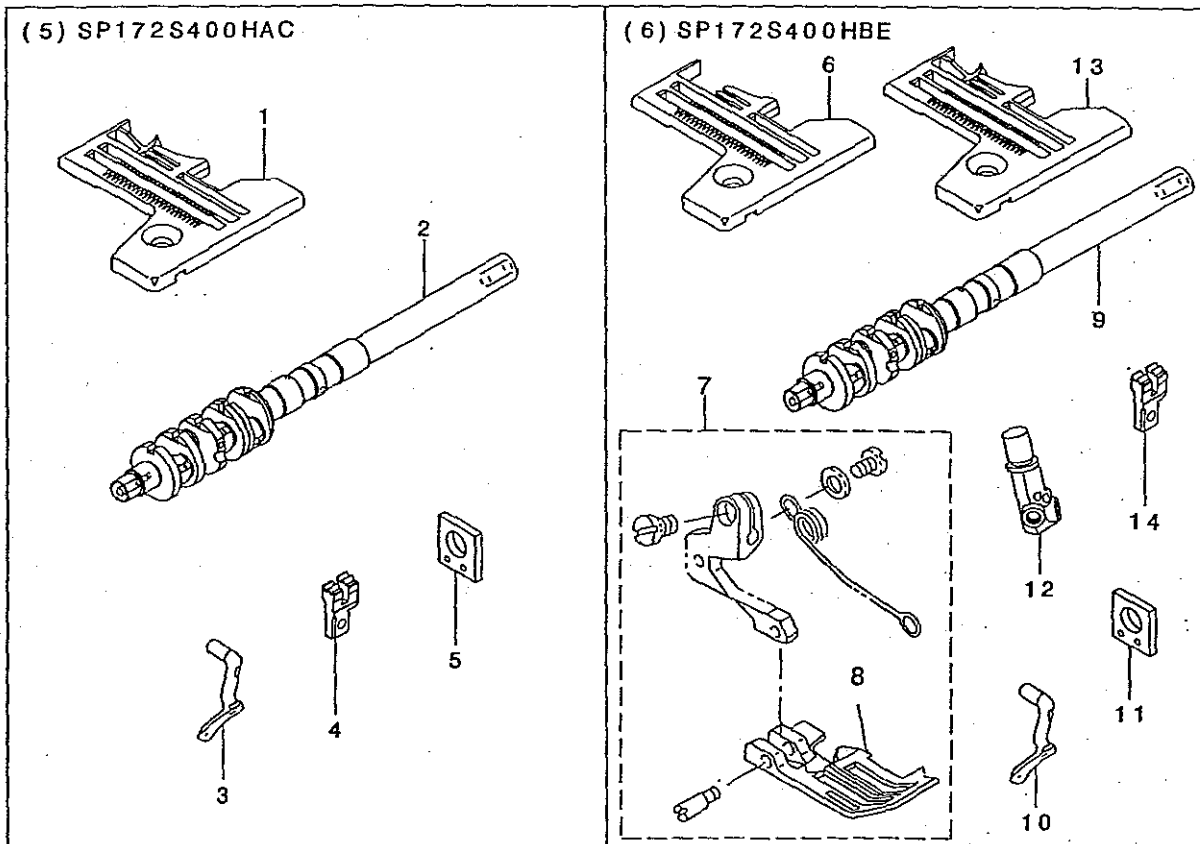

REF. NO	NOTE	PART NO.	DESCRIPTION	ヒソメイ	Qty
1	#01	R4305-KOD-EOA	THROAT PLATE	ハリタ	1
2		122-92108	MAIN SHAFT	シュツク	1
3		122-47102	UPPER LOOPER	ウエルパー	1
4	#01	122-38200	AUXILIARY FEED DOG	ホジヨクリハ	1
5		118-93609	GAUGE	ウツルハガイトササエケツ	1
6		R4306-KOF-EOO	THROAT PLATE	ハリタ	1
7		119-42653	PRESSER FOOT ASM.	オサエ(クミ)	1
8		119-42604	PRESSER FOOT	オサエ	(1)
9		122-92108	MAIN SHAFT	シュツク	1
10		122-47102	UPPER LOOPER	ウエルパー	1
11		118-93609	GAUGE	ウツルハガイトササエケツ	1
12		121-49209	NEEDLE CLAMP, 2-NEEDLE	ニホンハリハトメ	1
13	#02	R4306-KOF-EOA	THROAT PLATE	ハリタ	1
14	#02	122-38200	AUXILIARY FEED DOG	ホジヨクリハ	1

NOTE (注記)

#01...P04/Q01 EXCHANGING PARTS

P04/Q01交換部品

#02...P08/Q01 EXCHANGING PARTS

P08/Q01交換部品

*ALL PARTS NOT MENTIONED ABOVE ARE SAME AS THOSE OF SP172S400MACC
上記以外の部品は、SP172S400MACCと共通です。

NUMERICAL INDEX OF PARTS

索引

PART NO 品番	PAGE 頁	REF NO	PART NO 品番	PAGE 頁	REF NO	PART NO 品番	PAGE 頁	REF NO	PART NO 品番	PAGE 頁	REF NO
BT-0400251-ED	28	8	CQ-2020000-00	30	29	R4300-KOE-E00	36	12	SQ-0000451-MZ	30	55
BT-0500300-EA	30	57	CQ-2520000-00	8	47	R4300-KOF-E0A	36	33	SQ-1110401-MZ	30	15
BT-0500300-EA	30	60	CQ-2520000-00	14	75	R4300-KOF-E00	36	22	SQ-1110451-MZ	30	18
BT-0500300-EG	30	62	CS-0790731-SH	12	9	R4305-KOD-E0A	26	32	SQ-1110451-MZ	30	51
BT-0500300-EG	30	65	CS-087081B-SH	12	67	R4305-KOD-E0A	37	1	SQ-1110451-MZ	30	58
BT-0600402-EA	8	4	CS-087081C-SH	12	71	R4305-KOD-E00	26	27	SQ-1150441-SD	30	56
B1140-716-000	2	11	CS-100101D-SH	18	52	R4306-KOF-E0A	37	13	SQ-1150451-MZ	30	52
B1211-804-000	6	17	CS-100101E-SH	14	33	R4306-KOF-E00	37	6	SQ-1150454-SD	30	48
B1211-804-000	6	52	CS-100101E-SH	16	31				SS-2090520-SL	2	9
B1212-704-000	6	16	CS-100101E-SH	16	33	SB-3120003-0A	6	4	SS-2090830-SL	24	41
B1528-804-000-A	22	2	CS-1031210-SH	18	2	SB-3120003-0B	6	5	SS-2110710-TP	14	44
B1534-804-000	20	22	CS-111101H-SH	14	35	SB-3120003-0C	6	6	SS-2110910-SL	26	13
B1536-804-000	12	72	CS-111101H-SH	27	5	SB-3120003-0D	6	7	SS-3090610-SP	2	15
B1612-804-000	14	31	CS-120101B-SH	12	52	SB-3120003-0E	6	8	SS-3090610-SP	18	21
B1620-804-000	12	38	CS-1201010-SH	8	9	SB-3350002-0A	10	25	SS-3090610-SP	18	24
B1646-704-000-A	12	63				SB-3350002-0B	10	26	SS-4060310-SP	27	8
B1646-704-000-A	16	30	D8204-555-D00	33	4	SB-3350002-0C	10	27	SS-4060310-SP	27	16
B1647-704-000-A	12	62				SB-3350002-0D	10	28	SS-4080610-SP	18	39
B1652-704-000	10	8	MAO-11532000	32	25	SB-3350002-0E	10	29	SS-4090515-SP	16	45
B1707-155-000	12	39	MAO-11532000	32	57	SD-0260271-SP	10	20	SS-4090615-SP	18	29
B2024-771-000	14	32	MC-0336006-50	35	7	SD-0280401-SL	8	42	SS-4110515-SP	8	28
B2024-771-000	27	22	MC-0336007-50	8	12	SD-0461001-SP	16	41	SS-4110615-SP	30	19
B2530-704-000	18	15	MC-0336007-50	8	18	SD-0640321-TP	12	55	SS-4110815-SP	26	24
B2531-704-000	18	56	MDC-270B0900	35	6	SK-2351600-SC	33	7	SS-4112215-SP	30	13
B3013-141-H0A	4	25				SK-3311500-SC	33	2	SS-4120615-SP	2	24
B3101-804-000	24	16	NM-6040000-SN	14	38	SK-3382001-SE	32	28	SS-4151215-SP	4	46
B3102-804-000	24	7	NM-6050001-SE	32	4	SK-3412000-SC	4	43	SS-5080212-TP	6	12
B3103-804-000	24	25	NM-6050001-SE	32	9	SM-0030301-SN	16	42	SS-5110710-SP	4	23
B3112-704-000	24	6	NM-6050001-SE	32	16	SM-0081001-SD	4	37	SS-5110740-TP	6	1
B3112-704-000	24	15	NM-6050001-SE	32	22	SM-1040801-SC	4	10	SS-6080340-SP	10	11
B3112-704-000	24	24	NM-6050001-SE	32	36	SM-1040801-SC	4	16	SS-6080410-SP	12	50
B3120-352-000	24	11	NM-6050001-SE	32	44	SM-4040601-SC	4	18	SS-6080410-SP	18	13
B3120-352-000	24	20	NM-6050001-SE	32	50	SM-4040655-SP	2	14	SS-6080720-SP	8	37
B3120-352-000	24	29	NM-6060001-SE	32	56	SM-4040655-SP	18	20	SS-6090610-SP	18	64
B3120-704-000	24	9	NM-6060003-SC	20	28	SM-4040655-SP	35	5	SS-6090630-SP	18	16
B3120-704-000	24	18	NM-6080011-SF	14	39	SM-4040855-SP	4	11	SS-6090630-SP	33	8
B3120-704-000	24	27	NS-6090310-SN	2	12	SM-4040855-SP	4	15	SS-6090630-TP	18	60
B3126-012-000	24	10	NS-6090310-SP	24	42	SM-4040855-SP	8	32	SS-6090650-SP	22	10
B3126-012-000	24	19	NS-6110310-SP	30	16	SM-4040855-SP	8	36	SS-6090650-SP	30	14
B3126-012-000	24	28	NS-6110310-SP	30	59	SM-4040855-SP	12	13	SS-6090670-TP	8	21
B3228-771-00B	12	34	NS-6110310-SP	34	11	SM-4040855-SP	12	27	SS-6090810-TP	12	16
B3304-704-000-A	32	14	NS-6110420-SP	20	39	SM-4040855-SP	28	11	SS-6090810-TP	12	22
B3304-704-000-A	32	42	NS-6150430-SP	14	65	SM-4041055-SP	2	25	SS-6090910-TP	12	28
B3305-704-000-A	32	7	NS-6240630-SN	33	14	SM-4041455-SN	24	44	SS-6110420-TP	14	45
B3305-704-000-A	32	35	NS-6680320-SP	34	12	SM-4050855-SP	2	7	SS-6110480-SP	26	17
B3309-704-0A0	32	10	NS-6680410-SP	4	32	SM-4050855-SP	12	59	SS-6110520-TP	14	46
B3309-704-0A0	32	38				SM-4050855-SP	26	19	SS-6110610-TP	2	31
B3309-704-000	32	13	PS-0150065-KP	26	30	SM-4051055-SP	2	29	SS-6110710-TP	14	47
B3309-704-000	32	41	PS-0150082-KH	16	12	SM-4051055-SP	6	44	SS-6110710-TP	20	31
B3311-012-000	32	20	PS-0200062-KH	18	57	SM-4051255-SP	4	4	SS-6110820-TP	12	32
B3311-012-000	32	48	PS-0300132-KH	4	38	SM-4051405-SE	32	8	SS-6110820-TP	14	48
B3311-704-000	32	5	PS-0300132-KH	10	19	SM-4051405-SE	32	26	SS-6111010-TP	12	33
B3311-704-000	32	31	PS-0300132-KH	24	45	SM-4051405-SE	32	37	SS-6111052-TP	20	6
B3311-804-000	32	11				SM-4051601-SC	30	53	SS-6111110-SP	10	23
B3311-804-000	32	39	RE-0300000-KO	16	37	SM-4060801-SE	30	31	SS-6111140-SP	18	62
B3317-704-000	32	23	RE-0320000-KO	10	6	SM-4061201-SE	32	55	SS-6111610-SP	34	13
B3317-704-000	32	52	RE-0400000-KO	12	4	SM-6030510-SC	16	43	SS-6120620-TP	30	64
B3318-704-L00-A	32	29	RE-0400000-KO	14	40	SM-6053000-SE	32	15	SS-6121020-SP	14	66
B3319-704-L00	32	33	RE-0400000-KO	16	38	SM-6053000-SE	32	43	SS-6121020-SP	20	25
B3320-704-L00-A	32	19	RE-0900000-KO	16	39	SM-6061200-SP	18	37	SS-6121020-SP	30	28
B3320-704-L00-A	32	47	RO-0371801-00	12	12	SM-6061200-SP	20	27	SS-6121220-TP	12	40
B3321-704-LOB	32	58	RO-0371801-00	18	27	SM-6061202-TP	6	33	SS-6660610-TP	12	70
B3321-704-L00	32	54	RO-0601501-00	12	66	SM-6061202-TP	8	2	SS-6660710-TP	10	15
B3525-704-000	14	37	RO-0681901-00	16	40	SM-6061202-TP	8	15	SS-6660710-TP	16	47
B3525-704-000	14	52	RO-0742401-00	4	36	SM-6061210-SC	16	49	SS-7060310-SP	30	30
B3534-352-000	30	7	RO-0781901-00	4	47	SM-6061610-SC	16	50	SS-7060510-SP	22	3
B9112-804-000	34	3	RO-1082401-00	8	45	SM-6061610-SC	32	30	SS-7060510-SP	26	14
B9135-123-0B0	34	4	RO-1100901-00	20	16	SM-6061802-TP	30	46	SS-7060610-SP	12	17
			RO-1100901-00	20	18	SM-8040402-TP	20	15	SS-7060610-SP	18	31
			RO-2182401-00	30	50	SM-8050402-TP	30	26	SS-7080520-SP	22	6
CM-3002000-01	2	33	RO-3152001-00	2	4	SM-9051203-CP	14	41	SS-7080520-SP	26	21
CM-3002001-A1	4	45	RO-3473501-00	6	42	SM-9061250-TP	14	42	SS-7090410-SP	14	49
CM-5002000-01	4	8	R4200-KOD-D00	26	26	SM-9061250-TP	14	43	SS-7090530-SP	2	13
CQ-2000000-00	18	51	R4300-KOD-E0A	36	10	SM-9061250-TP	16	11	SS-7090540-TP	12	58
CQ-2000000-00	28	7	R4300-KOD-E00	36	1	SM-9061250-TP	16	44	SS-7090540-TP	28	9
CQ-2020000-00	14	67	R4300-KOE-E0A	36	20	SM-9061250-TP	27	3	SS-7090540-TP	34	15
CQ-2020000-00	18	50									

NUMERICAL INDEX OF PARTS

索引

PART NO 品番	PAGE 頁	REF NO	PART NO 品番	PAGE 頁	REF NO	PART NO 品番	PAGE 頁	REF NO	PART NO 品番	PAGE 頁	REF NO
SS-7090610-SP	2	17	TA-0180401-MO	14	53	118-23606	27	19	121-07702	6	43
SS-7090611-SL	4	27	TA-0180401-MO	14	54	118-23705	27	20	121-07801	6	45
SS-7090850-SP	18	18	TA-0290301-MO	30	32	118-23804	8	44	121-09104	6	26
SS-7090910-SP	28	10	TA-0340201-RO	14	27	118-23804	10	9	121-09153	6	25
SS-7110510-SP	20	10	TA-0340201-RO	14	55	118-23804	27	18	121-09211	8	3
SS-7110510-SP	26	22	TA-0400301-MO	30	27	118-23903	27	21	121-09260	8	1
SS-7110540-SP	32	12	TA-0400301-MO	30	63	118-26005	16	25	121-09302	8	5
SS-7110540-SP	32	40	TA-0620504-RO	24	40	118-26104	16	26	121-09500	8	8
SS-7110740-TL	24	43	TA-0750704-RO	4	39	118-26203	16	27	121-09617	8	14
SS-7110740-TP	14	50	TA-0800501-RO	14	56	118-28050	12	7	121-09666	8	13
SS-7110840-SP	6	22	TA-0800504-RO	4	40	118-31708	18	49	121-09906	8	48
SS-7110840-SP	6	23	TA-0950806-RO	28	15	118-31757	18	47	121-09955	8	46
SS-7110840-SP	18	11	TA-1450404-RO	2	6	118-31807	18	26	121-10219	8	24
SS-7110840-SP	20	9	TA-1470702-RO	4	41	118-31906	18	25	121-10607	8	39
SS-7110840-SP	20	32	TA-1701107-RO	4	22	118-33407	18	22	121-10805	8	41
SS-7110840-SP	26	15				118-33506	18	12	121-10904	8	40
SS-7110840-SP	34	14	WP-0371016-SD	16	35	118-40303	30	8	121-11209	8	27
SS-7110910-SP	2	32	WP-0371026-SD	12	29	118-41707	30	4	121-11308	8	29
SS-7110910-TP	10	31	WP-0371026-SD	22	7	118-43208	30	45	121-11803	8	31
SS-7110910-TP	24	46	WP-0371026-SD	28	16	118-45807	27	14	121-11902	8	33
SS-7111410-SP	6	24	WP-0371036-SD	14	57	118-45906	35	4	121-12108	8	35
SS-7111410-SP	20	41	WP-0451026-SH	12	44	118-48405	27	1	121-12207	8	11
SS-7111410-TP	6	31	WP-0451026-SH	14	58	118-56101	28	5	121-12306	8	7
SS-7111410-TP	6	38	WP-0460556-SD	16	36	118-93609	36	29	121-13205	20	23
SS-7111810-TP	6	21	WP-0621016-SD	12	61	118-93609	37	5	121-13817	20	33
SS-7111810-TP	6	27	WP-0621016-SD	16	46	118-93609	37	11	121-14609	20	14
SS-7111810-TP	6	29	WP-0621016-SH	14	59	118-98400	16	28	121-14807	20	29
SS-7111810-TP	6	36	WP-0651056-SD	30	47	119-13407	14	29	121-14906	20	17
SS-7111810-TP	12	45	WP-0751576-SD	4	30	119-14405	14	30	121-15903	20	42
SS-7150910-TP	34	16	WP-0764016-SP	6	49	119-18109	30	6	121-16703	16	29
SS-7161040-SP	20	35	WP-0841600-OE	34	17	119-25104	22	9	121-18303	12	25
SS-8080310-TP	8	19	WP-1102016-SC	33	12	119-25914	22	13	121-18600	10	7
SS-8080310-TP	8	43	WP-1612616-SE	32	24	119-26102	36	32	121-18709	12	65
SS-8080310-TP	26	16	WP-1612616-SE	32	53	119-26300	22	14	121-22107	6	30
SS-8080310-TP	26	20	WS-0822010-KP	4	31	119-30500	22	11	121-22107	6	37
SS-8080322-TP	34	1	WS-1002560-KR	33	13	119-30609	22	12	121-22313	6	32
SS-8080322-TP	34	2	WZ-0850302-KO	4	24	119-30609	36	8	121-22362	6	28
SS-8080410-TP	6	13	WZ-0850302-KO	34	18	119-30609	36	18	121-22404	18	5
SS-8080410-TP	26	31	WZ-2640310-KH	6	41	119-30609	36	31	121-22511	18	4
SS-8090530-TP	8	16				119-30906	22	8	121-22610	18	1
SS-8110410-TP	2	19	100-04109	2	34	119-32068	22	4	121-22800	18	42
SS-8110410-TP	12	8	101-26803	30	44	119-32258	36	30	121-22859	18	41
SS-8110410-TP	12	10	111-11705	26	18	119-32456	22	5	121-22909	18	34
SS-8110410-TP	12	68	111-55108	33	15	119-35764	35	8	121-23204	18	33
SS-8110410-TP	12	73	111-55207	33	16	119-36614	14	62	121-23808	18	19
SS-8110410-TP	30	5	111-85006	32	21	119-36804	14	63	121-23907	18	23
SS-8110422-TP	6	3	111-85105	32	17	119-36804	36	2	121-24004	18	65
SS-8110422-TP	26	28	111-85105	32	45	119-36804	36	13	121-24202	18	17
SS-8110520-TP	10	24	111-85204	32	6	119-36804	36	23	121-24400	6	34
SS-8110520-TP	20	21	111-85204	32	34	119-39311	35	1	121-24509	6	18
SS-8110520-TP	30	33	111-85352	32	2	119-42604	37	8	121-26108	24	47
SS-8110710-SP	8	26	111-85402	32	3	119-42653	37	7	121-26207	24	3
SS-8151150-SP	6	48	111-85501	32	18	119-60002	33	6	121-26405	24	12
SS-8660330-SP	14	36	111-85501	32	46	119-66504	32	49	121-26405	24	21
SS-8660330-SP	27	6	115-00808	4	2	119-68609	33	5	121-26405	24	30
SS-8660410-SP	12	53	115-03703	4	29	119-69458	32	1	121-26504	24	37
SS-8660530-TP	14	34	115-10609	6	53	119-69508	32	51	121-26702	24	8
SS-8660530-TP	16	32	115-17000	18	48	119-69573	32	32	121-26702	24	17
SS-8660530-TP	16	34	115-29005	12	60	119-69953	32	27	121-26702	24	26
SS-8660530-TP	18	53	115-29005	16	24	121-00301	4	14	121-26819	24	14
SS-8660610-TP	8	10	115-29914	12	5	121-00418	4	1	121-26868	24	13
SS-8660610-TP	18	3	115-65504	27	17	121-00517	4	12	121-26918	24	5
SS-9090410-TP	18	36	115-65702	27	15	121-00608	4	3	121-26967	24	4
SS-9090610-TP	16	48	115-65801	27	9	121-00806	4	5	121-27015	24	23
SS-9090610-TP	18	10	115-66809	14	28	121-01408	2	22	121-27064	24	22
SS-9111610-SP	27	12	115-66809	27	10	121-01515	2	10	121-27403	24	31
SS-9151210-TP	4	20	115-71403	33	10	121-01804	4	9	121-27502	24	32
SS-9151210-TP	6	40	115-71601	33	3	121-01903	4	7	121-27601	24	33
SS-9151210-TP	10	2	115-98000	27	13	121-01960	4	6	121-27700	24	34
SS-9151210-TP	12	51	118-03004	2	16	121-02000	4	26	121-27809	24	35
SS-9151210-TP	14	64	118-05207	4	21	121-02513	4	44	121-27957	24	36
SS-9151210-TP	18	9	118-06304	34	10	121-03206	2	21	121-28203	24	38
SS-9151210-TP	18	43	118-11619	6	46	121-03404	2	26	121-28302	24	39
SS-9151210-TP	18	59	118-15107	30	61	121-04907	4	28	121-29318	30	17
SS-9151210-TP	20	34	118-19109	20	37	121-05201	4	42	121-29706	30	35
SS-9681610-TP	6	50	118-19315	20	36	121-07611	6	47	121-29805	30	22

NUMERICAL INDEX OF PARTS

索引

PART NO 品番	PAGE 頁	REF NO	PART NO 品番	PAGE 頁	REF NO	PART NO 品番	PAGE 頁	REF NO	PART NO 品番	PAGE 頁	REF NO
121-30100	30	36	122-14607	36	5	122-53100	8	25	123-10900	14	20
121-30209	30	37	122-14607	36	16	122-53209	8	38	123-10900	20	13
121-30308	30	38	122-14607	36	27	122-58000	4	33	123-11007	14	22
121-30407	30	39	122-14656	18	7	122-60204	4	17	123-11106	14	23
121-30506	30	40	122-14706	18	35	122-60303	10	32	123-11304	16	16
121-30605	30	41	122-14755	18	32	122-90151	2	23	123-11403	16	17
121-30704	30	42	122-14805	18	30	122-90409	4	35	123-11502	16	18
121-30803	30	43	122-14904	18	45	122-90458	4	34	123-11809	16	20
121-32106	6	20	122-15000	18	46	122-92009	6	11	123-11908	16	21
121-32155	6	19	122-15109	6	39	122-92108	36	26	123-12005	16	22
121-32502	27	4	122-15158	6	35	122-92108	37	2	123-12104	16	23
121-38152	28	13	122-15208	18	44	122-92108	37	9	123-12203	14	24
121-38301	28	14	122-15307	18	55	122-92504	16	6	123-12302	14	25
121-38400	28	12	122-15356	18	54	122-92603	14	2	123-15008	30	1
121-48607	8	30	122-15406	18	63	122-92702	16	15	123-15503	30	49
121-48706	8	34	122-15554	18	14	122-92850	16	19	123-15602	30	54
121-49209	37	12	122-15604	18	61	122-93551	30	20	123-15800	30	34
121-80162	24	1	122-15703	18	28	122-93601	30	24	123-15909	30	3
121-80261	24	2	122-19101	26	1	122-93700	30	23	123-16006	30	10
121-80360	35	3	122-19200	26	8	122-93759	30	21	123-16105	30	11
122-00200	2	1	122-19358	26	9	122-93809	30	25	123-16204	30	12
122-00309	2	2	122-19507	26	7	122-93957	30	2	123-16402	14	69
122-00408	2	3	122-19606	26	6	123-00109	2	27	123-16501	14	70
122-00507	2	5	122-19705	26	25	123-00208	2	28	123-16600	14	68
122-00804	2	20	122-19804	26	3	123-00505	2	30	123-16709	14	71
122-00903	2	18	122-19903	26	2	123-04002	8	22	123-16808	14	72
122-01208	4	19	122-20000	26	10	123-04101	8	20	123-16907	14	73
122-03816	6	51	122-20109	26	5	123-05009	20	24	123-17004	30	9
122-03907	6	15	122-20208	26	12	123-05256	20	30	123-17103	14	74
122-04004	6	2	122-20307	26	11	123-05405	14	60	123-17202	14	51
122-04103	6	14	122-20406	36	6	123-05504	14	61	123-18002	27	2
122-04202	6	10	122-20505	26	23	123-05603	22	1	123-18101	27	7
122-06603	20	40	122-20604	26	29	123-05702	20	19	123-20404	36	9
122-06702	20	38	122-21602	33	1	123-05850	20	20	123-20404	36	19
122-08104	10	14	122-21750	33	11	123-05900	20	12	123-20453	36	7
122-08153	10	13	122-21800	33	9	123-05959	20	11	123-20453	36	17
122-08203	10	16	122-24606	28	3	123-06106	20	2	135-08700	18	58
122-08302	10	17	122-24655	28	1	123-06155	20	1			
122-08401	10	18	122-24705	28	4	123-06205	20	3			
122-08500	10	21	122-24853	28	2	123-06353	20	4			
122-08609	10	12	122-25009	28	6	123-06551	20	5			
122-08708	10	22	122-26155	34	5	123-06601	20	7			
122-08807	10	10	122-26163	34	6	123-06700	20	8			
122-08906	10	30	122-26304	34	7	123-06809	20	26			
122-09003	10	3	122-26403	34	8	123-08003	16	1			
122-09052	10	1	122-26502	34	9	123-08102	16	2			
122-09102	12	35	122-29100	2	8	123-08201	16	3			
122-09201	12	36	122-35107	12	14	123-08300	14	26			
122-09300	12	37	122-35206	12	15	123-08300	16	4			
122-09409	12	48	122-35206	36	3	123-08409	14	21			
122-09458	12	46	122-35206	36	14	123-08409	16	5			
122-09508	12	47	122-35206	36	24	123-08607	16	7			
122-09607	12	49	122-36600	12	20	123-08706	16	9			
122-09706	12	43	122-36709	12	21	123-08755	16	8			
122-09805	12	42	122-36709	36	4	123-08805	16	10			
122-09904	12	2	122-36709	36	15	123-08904	16	13			
122-09953	12	1	122-36709	36	25	123-09001	16	14			
122-10001	12	3	122-38101	12	18	123-09100	14	1			
122-10100	6	9	122-38200	12	74	123-09308	14	3			
122-10217	12	11	122-38200	36	11	123-09407	14	4			
122-10308	12	6	122-38200	36	21	123-09506	14	5			
122-10407	12	26	122-38200	36	34	123-09605	14	6			
122-10506	12	24	122-38200	37	4	123-09704	14	7			
122-10605	12	23	122-38200	37	14	123-09803	14	8			
122-10704	12	30	122-40107	18	6	123-09803	27	11			
122-10803	12	31	122-40602	18	40	123-09902	14	9			
122-10902	12	41	122-40701	26	4	123-10009	14	10			
122-11009	12	54	122-47102	36	28	123-10108	14	11			
122-11157	12	64	122-47102	37	3	123-10207	14	12			
122-11306	12	69	122-47102	37	10	123-10306	14	13			
122-11405	12	56	122-47300	18	38	123-10405	14	14			
122-11504	12	19	122-47508	35	2	123-10504	14	15			
122-11603	12	57	122-50205	4	13	123-10603	14	16			
122-11702	10	5	122-52805	8	6	123-10702	14	17			
122-11801	10	4	122-52904	8	17	123-10801	14	19			
122-14607	18	8	122-53050	8	23	123-10850	14	18			

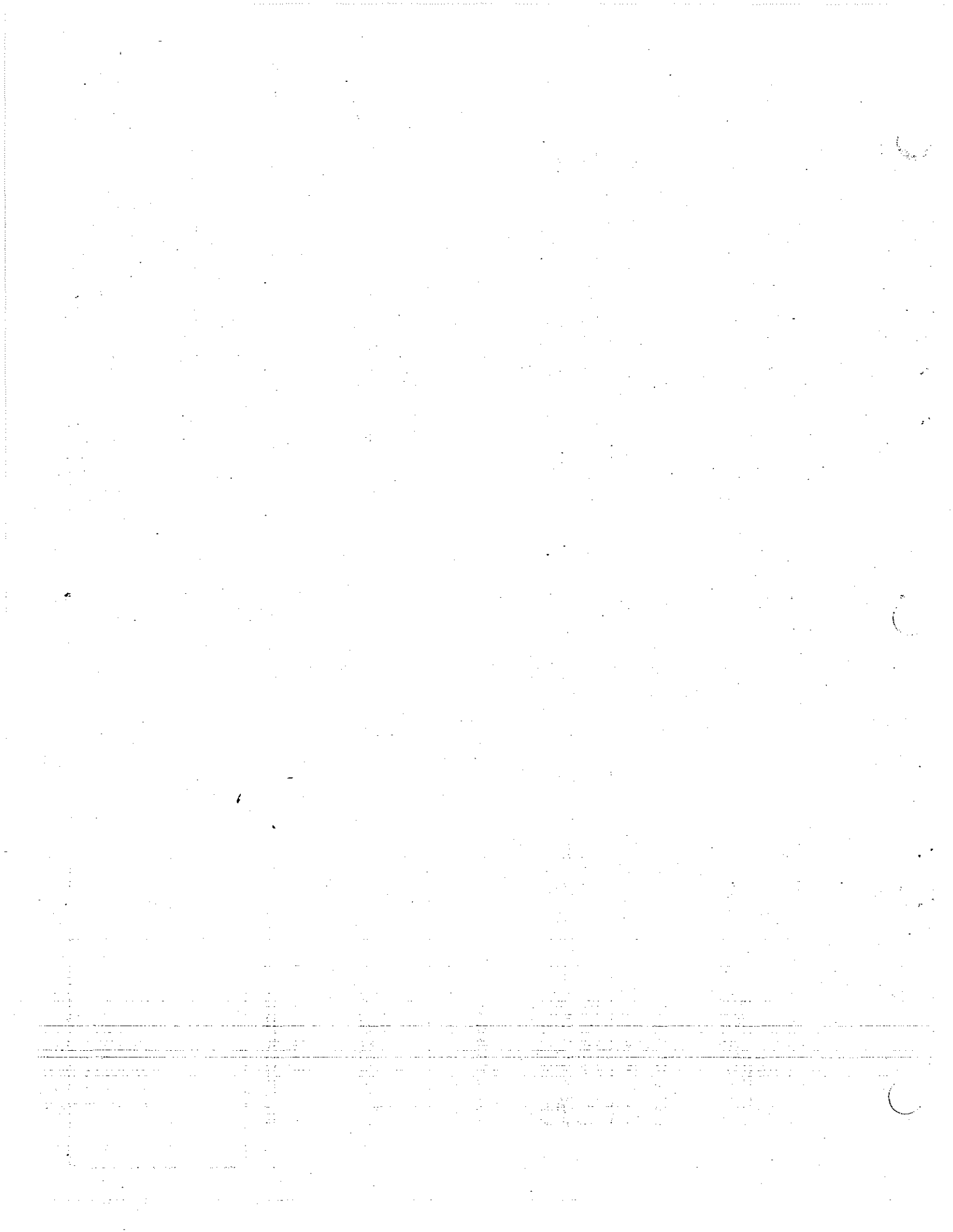

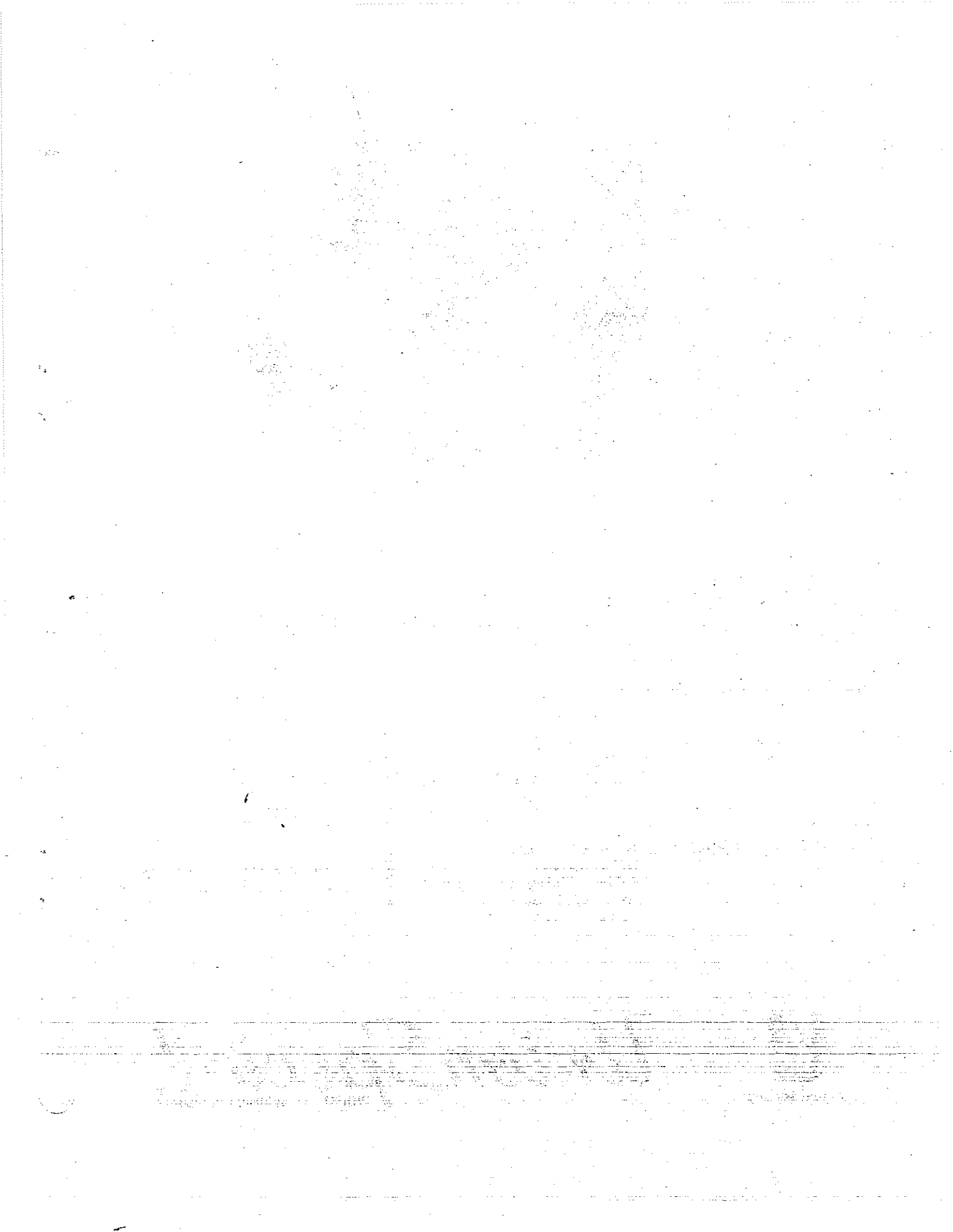

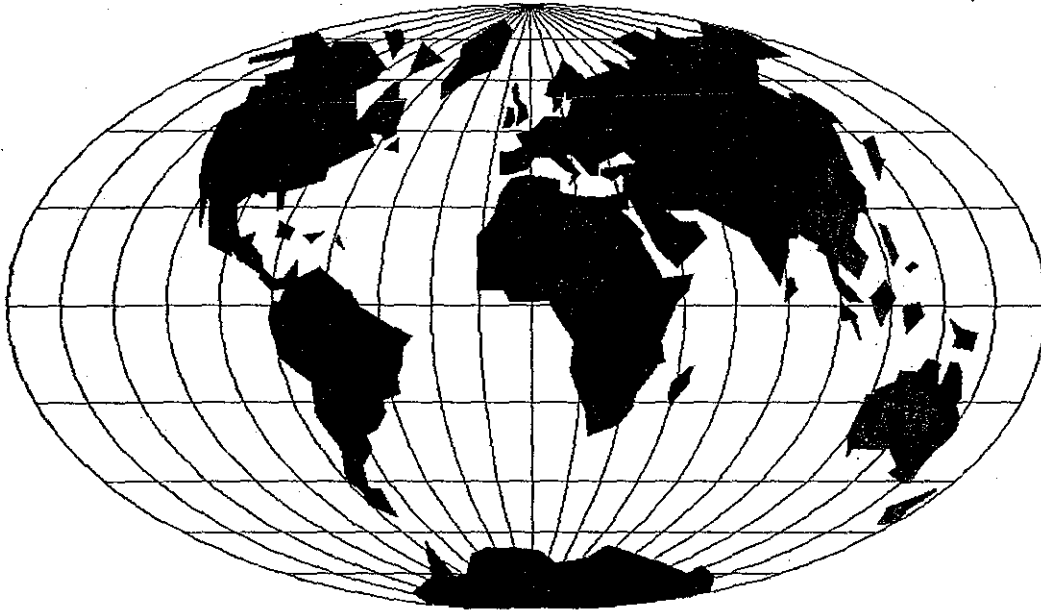

WORLDWIDE SALES AND SERVICE

Union Special Corporation maintains sales and service facilities throughout the world. These offices will aid you in the selection of the right sewing equipment for your particular operation. Union Special Corporation representatives and service technicians are factory trained and are able to serve your needs promptly and efficiently. Whatever your location, there is a qualified representative to serve you.

Corporate Office: One Union Special Plaza
Huntley, IL 60142
Phone: 847•669•5101
Fax: 847•669•1096

European Distribution Center: Union Special GmbH
Raiffeisenstrasse 3
D-71696 Möglingen, Germany
Tel: 49•07141•247•0
Fax: 49•7141•247•100

Brussels, Belgium
Charlotte, N.C.
El Paso, TX
Hong Kong, China
Huntley, IL
Leicester, England
Lille, France
Miami, FL
Milan, Italy
Möglingen, Germany
Montreal, Quebec
Osaka, Japan
Santa Fe Springs, CA

Other Representatives throughout
all parts of the world.



Union Special
INDUSTRIAL SEWING EQUIPMENT