

Rinoldi

CATALOGO PEZZI DI RICAMBIO
SPARE PARTS CATALOGUE - ERSATZTEILELISTE
CATALOGUE RECHANGES - CATALOGO REPUESTOS

329-00-2CD-10

329-00-2CD-12

329-00-3MU-01

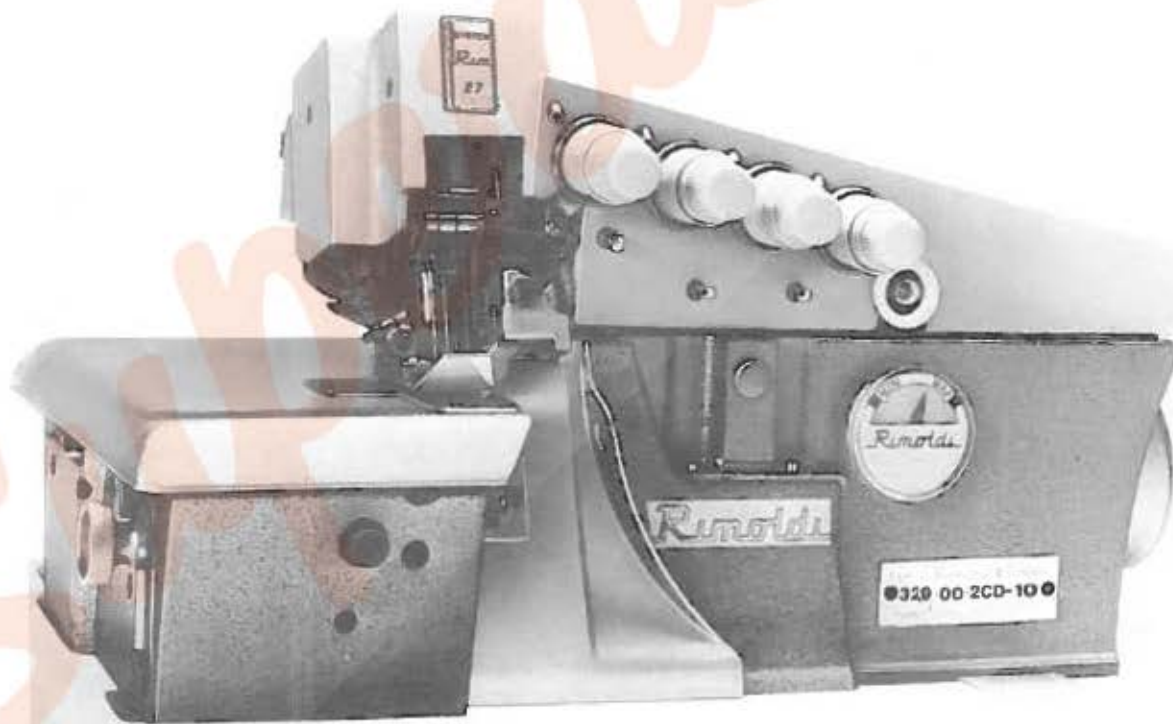

n.72-3-72

Il presente Catalogo Pezzi di Ricambio è costituito da due parti: la prima, definita come "Catalogo base" (da Tav. 1 a Tav.19), comprende i particolari montati sulla testa più significativa (la prima dell'elenco in copertina); la seconda (da Tav. — in avanti) comprende tutti i particolari delle altre teste basi o derivate, che differiscono da quella del Catalogo base.

Le Teste basi sono elencate in copertina con un carattere più grande rispetto a quello delle derivate.

Nella consultazione del Catalogo tenere presente che:

1. Tutti i particolari non fornibili scolti non vengono richiamati singolarmente, ma soltanto illustrati nel gruppo d'appartenenza.
2. I riferimenti delle figure dei particolari che compongono il gruppo sono di norma raggruppati in una parentesi. In alcuni casi però, dove non è possibile il raggruppamento, i numeri che nelle tavole illustrative richiamano i singoli pezzi sono affiancati dallo stesso segno particolare, con cui è indicato l'intero gruppo.
3. Sulle tavole relative alle altre teste (da Tav. — in avanti) sono elencati tutti i particolari diversi o non montati sulla testa del Catalogo Base. Dette tavole portano in alto a destra il simbolo della testa cui si riferiscono (con indicato fra parentesi - nel caso di derivata - il simbolo della testa da cui deriva). I disegni di questo gruppo di tavole illustrano soltanto i pezzi nuovi o sostanzialmente diversi rispetto a quelli montati sulla testa più significativa del Catalogo. I particolari richiamati come simbolo, ma non illustrati, conservano lo stesso numero di figura dei corrispondenti raffigurati sul Catalogo base. I particolari comuni a tutte le teste comprese nel Catalogo, vengono richiamati soltanto nel primo gruppo di tavole e cioè da Tav. 1 a Tav. 19. I particolari definiti come "pezzi annullati" si intendono quelli non montati sulla testa a cui la tavola si riferisce.

Per facilitare la ricerca viene riportato l'indice numerico di tutti i particolari illustrati sul Catalogo base, con la relativa tavola in cui gli stessi sono richiamati.

AGHI

Gli aghi sono contraddistinti dal sistema e dalla finezza, la quale indica il diametro medio espresso in centesimi di millimetro.

Il sistema dell'ago e la finezza sono marcati oltre che sulla busta, anche sull'ago stesso.

Nelle ordinazioni precisare, oltre al simbolo, il sistema e la finezza degli aghi desiderati. In caso di dubbio, allegare, un ago campione o una bustina vuota.

AVVERTENZA

Nella richiesta di parti di ricambio citare sempre il relativo numero di matricola della macchina, il simbolo del particolare e la denominazione ufficiale usata sul catalogo.

This spare parts catalogue is made up of two parts: in the first one, called "basic catalogue" (from Table 1 to Table 19), all the details of most representative head are listed (the first head listed on the cover); the second one (from Table — onwards) includes the details of the other main heads or derived ones, which are different from that of the basic catalogue. The main heads are listed on the cover in bigger lettering to distinguish them from the derived heads.

When you consult the catalogue will you please note that:

1. all parts which cannot be supplied by themselves are not indicated alone, but shown together with the group to which they belong;
2. the references of the pictures of the parts making up the group are usually put in brackets. In some cases, however, when their grouping is not possible, the numbers of the various parts in the tables are marked with the same particular sign with which the whole group is indicated.
3. in the tables of the other heads (from Table — onward) there are listed all the parts not fitted on the head in the basic catalogue. These tables are marked at the top right-hand corner with the symbol of the head which the table refers to. The drawings in this group of tables show only the parts which are new or basically different from those fitted on the most representative head in the catalogue. The parts which are represented only by the symbol but not illustrated keep the same figure number as the corresponding parts shown in the basic catalogue. The parts which are common to all the heads in the catalogue are listed only in the first group of table, that is from Table 1 to Table 19. Parts marked "annulled part" are those not fitted on the head which the table refers to.

To make it easier to locate the parts, the reference numbers of all of those shown in the basic catalogue are listed together with the number of the table in which they are to be found.

NEEDLES

The needles are marked with system and size; the size indicates the average diameter in hundredths of a millimetre.

The system and size of the needle are shown on the packet as well as on the needle itself.

When ordering please state symbol, system and size. If you have doubts, enclose a sample needle or an empty packet with your order.

ATTENTION

When ordering spare parts always state the serial number of the machine, the symbol of the part in question and the description given in the catalogue.

TAV. N. TAB. N.	DESCRIZIONE	DESCRIPTION	
1	BASE E BUSSOLE	BASE AND BUSHES	329-00-2CD-10 – 329-00-2CD-12 29-00-3MU-01
2	PIANO DI LAVORO	WORKING PLATE	329-00-2CD-10 – 329-00-2CD-12 329-00-3MU-01
3	COPERCHI E SPORTELLI	COVERS AND DORS	329-00-2CD-10 – 329-00-2CD-12 329-00-3MU-01
4	COPERCHIO SUP.–TENSIONI–PASSAFILI	UPPER COVER–TENSION–THREAD GUIDE	329-00-2CD-10 – 329-00-2CD-12
4A	COPERCHIO SUP.–TENSIONI–PASSAFILI	UPPER COVER–TENSION–THREAD GUIDE	329-00-3MU-01
5	ALBERO PRINCIPALE	MAIN SHAFT	329-00-2CD-10 – 329-00-2CD-12
5A	ALBERO PRINCIPALE	MAIN SHAFT	329-00-3MU-01
6	TRASPORTO	TRANSPORT	329-00-2CD-10 – 329-00-2CD-12
6A	TRASPORTO	TRANSPORT	329-00-3MU-01
7	MOVIMENTO CROCHET	LOOPER CONTROL ASSEMBLY	329-00-2CD-10 – 329-00-2CD-12 329-00-3MU-01
8	MOVIMENTO CROCHET SICUREZZA	SAFETY LOOPER CONTROL ASSEMBLY	329-00-2CD-10 – 329-00-2CD-12
8A	MOVIMENTO CROCHET SICUREZZA	SAFETY LOOPER CONTROL ASSEMBLY	329-00-3MU-01
9	MOVIMENTO BARRA AGO	NEEDLE BAR	329-00-2CD-10 – 329-00-2CD-12
9A	MOVIMENTO BARRA AGO	NEEDLE BAR	329-00-3MU-01
10	GRUPPO PREMISTOFFA	PRESSER ASSEMBLY	329-00-2CD-10 – 329-00-2CD-12 329-00-3MU-01
11	GRUPPO COLTELLI	KNIFE ASSEMBLY	329-00-2CD-10 – 329-00-2CD-12
11A	GRUPPO COLTELLI	KNIFE ASSEMBLY	329-00-3MU-01
12	GRUPPO LUBRIFICAZIONE	LUBRICATION ASSEMBLY	329-00-2CD-10 – 329-00-2CD-12 329-00-3MU-01
13	ORGANI CUCITURA	SEWING PARTS	329-00-2CD-10
14	ORGANI CUCITURA	SEWING PARTS	329-00-2CD-12
15	ORGANI CUCITURA	SEWING PARTS	329-00-3MU-01
16	ACCESSORI IN DOTAZIONE	AUXILIARY EQUIPMENT	329-00-2CD-10 – 329-00-2CD-12 329-00-3MU-01
17	PIASTRA PORTA TESTA	HEAD HOLDER PLATE	329-00-2CD-10 – 329-00-2CD-12 329-00-3MU-01
18	PORTA BOBINE	BOBBIN CARRIER	329-00-2CD-10 – 329-00-2CD-12
19	PORTA BOBINE	BOBBIN CARRIER	329-00-3MU-01

CARATTERISTICHE TESTE MACHINE HEAD FEATURES	N. Aghi Needles N	N. Fili Threads N	Largh.costa Bight width	Posiz.Differ. Differ.posit.	g/1' max Max r.p.m.	N.punti per pollice Stitch per inch.	CARATTERISTICHE TESTA MACHINE HEAD FEATURES	N. Aghi Needles N	N. Fili Threads N	Largh.costa Bight width	Posiz.Differ. Differ.Posit.	g/1' max Max r.p.m.	N.punti per pollice Stitch per inch.
<p>329-00-2CD-10</p> <p>Per cuciture di assemblaggio su tessuti rigidi pesanti in trama e ordito. Dotata di piedino speciale con slitta lunga e di griffe con scanalature longitudinali per tessuti pesantissimi come blue-jeans, abiti da lavoro ecc. (eccentrico alza griffa con eccentricità 0,5 mm.). Dotata di crochet per lavorare anche a 5 fili.</p> <p>For assembly seaming on heavy woven fabrics and on fabrics which have undergone permanent press processing (sports, trousers, skirts, etc.). Fitted with special presserfoot with long slide and with feed dogs with lengthwise grooves for extra heavy fabrics such as denim, overalls, etc.. Equipped with looper to work also with 5 threads. Eccentricity of feed dog lifter eccentric:0,5 mm.</p>	2	4/5	5	-1	6500	7÷20	<p>329-00-3MU-01</p> <p>Per cucire i gambali e il cavallo di pantaloni pesanti, blue-jeans, pantaloni da lavoro ecc. Esegue due cuciture affiancate a punto catenella ed una cucitura a soprappiglio a 3 fili, refillando contemporaneamente il tessuto. Dispone di griffa unica a dentatura grossa per garantire un trasporto efficiente con tessuti pesanti.</p> <p>For seaming the legs and crutch of heavy trousers, jeans, work trousers, etc. It makes two rows of double locked chain stitching side by side and a 3-thread overlock seam, trimming at the same time the fabric. It has a single coarse-toothed feed-dog to guarantee efficient feeding of heavy fabrics.</p>	3	7	5	-	5500	7÷10
<p>329-00-2CD-12</p> <p>Per cuciture di assemblaggio su tessuti rigidi medi in trama e ordito. Dotata di piedino speciale con slitta lunga e di griffe con scanalature longitudinali per tessuti medi pesanti (eccentrico alza griffa con eccentricità 0,5 mm) Dotata di crochet per lavorare anche a 5 fili.</p> <p>For assembly seaming on medium woven fabrics undergone permanent press processing (linings, linen and cloth). Fitted with special presserfoot with long slide and with feed dogs with lengthwise grooves for medium-heavy fabrics. Eccentricity of feed dog lifter eccentric: 0,5 mm. Fitted with looper to work also with 5 threads.</p>	2	4/5	4,3	-1	6500	7÷20							

Part. N.	Tav. N.	Part. N.	Tav. N.	Part. N.	Tav. N.	Part. N.	Tav. N.	Part. N.	Tav. N.	Part. N.	Tav. N.	Part. N.	Tav. N.
100458-0-10	4A	202412-0-10	6-6A	204681-0-10	11-11A	204862-4-10	13-14	206044-0-10	15	206522-3-00	9-9A	206588-0-00	6-6A
100620-0-10	6-6A	202413-0-10	13-14-15	204685-2-10	11	204863-0-10	13-14-15	206046-3-01	15	206524-0-00	9-9A	206592-3-00	6-6A
204490-0-00	6-6A	202472-0-10	6-6A	204687-0-10	11-11A	204864-0-10	14	206047-3-01	8A	206525-3-00	9-9A	206593-0-00	6-6A
201128-0-10	7-7A	202473-0-10	6-6A	204690-0-10	11	204869-0-10	13-14-15	206048-0-10	15	206529-4-00	9-9A	206594-0-00	1
201358-0-10	6-6A	202475-0-10	6-6A	204691-0-10	11-11A	204878-0-10	13-14-15	206050-0-10	15	206530-4-00	9-9A	206595-0-00	1
201610-0-01	6-6A	202478-0-10	6-6A	204693-0-11	13-14	204889-0-10	13-14-15	206051-4-10	15	206531-0-00	9-9A	206598-3-00	6-6A
202026-0-10	2	202480-0-10	3	204694-0-10	13	204891-0-11	10	206052-0-10	11A	206532-0-00	5-5A	206599-0-00	6-6A
202027-0-10	3	202484-0-10	3	204699-0-11	11-11A	204894-0-10	13-14-15	206053-0-10	11A	206533-0-00	9-9A	206603-0-10	6-6A
202032-0-10	6	202487-0-10	8-8A	204700-0-10	7-7A	204895-0-10	13-14-15	206057-2-01	4A	206534-0-00	2	206605-0-01	6-6A
202033-0-10	6	202488-0-10	6	204704-0-10	4-4A	204905-0-10	6-6A	206060-4-01	4A	206535-0-00	4	206606-2-00	6-6A-9-9A
202047-2-10	6-6A	202489-0-10	6-6A	204747-0-10	4	204911-0-11	4-4A	206061-2-00	11A	206538-0-00	1	206608-0-00	6
202063-0-10	6	202490-0-10	6	204748-4-11	4	204912-0-10	8	206062-0-01	15	206539-0-00	1	206609-0-00	6-6A
202065-0-10	1	202492-0-10	5	204750-0-10	4-4A	204913-0-10	8	206257-4-00	4	206540-2-00	9	206613-0-00	6-6A
202071-2-10	5-5A	202529-0-10	10	204753-0-10	4	204940-0-10	14	206260-4-00	4A	206542-2-00	9A	206614-2-00	6-6A
202086-0-10	7-7A	202539-4-00	5-5A	204755-2-10	8-8A	204941-0-10	14	206317-3-00	4	206543-0-00	5-5A	206615-4-00	6-6A
202092-0-10	13-14-15	202556-0-00	4-4A	204756-0-10	4-4A	204942-0-10	14	206320-3-00	4A	206544-0-00	5-5A	206616-0-00	6A
202110-0-10	10	202558-2-00	4-4A	204757-0-11	5-5A	204943-0-11	14	206340-4-00	4-4A	206546-0-00	6-6A	206617-0-00	6
202128-0-10	11-11A	202572-4-11	11	204759-2-10	4	204947-0-10	13-14-15	206341-4-00	4	206549-2-00	5-5A	206618-0-00	6-6A
202129-0-10	11-11A	202609-0-10	13-14	204760-4-10	4	204948-0-10	14	206342-4-00	4-4A	206550-4-00	12	206619-0-00	6-6A
202130-0-10	11-11A	202681-0-10	4-4A	204761-0-10	4	204997-0-00	14	206343-4-00	4-4A	206555-0-00	12	206620-0-00	10
202131-0-10	11-11A	202683-0-10	4-4A	204762-0-11	8-8A	205007-0-10	13	206346-4-00	4	206556-0-00	5-5A	206621-0-00	10
202165-0-10	3	202720-0-00	7-7A	204764-3-10	8-8A	205009-2-11	13	206347-4-00	4A	206557-0-00	12	206622-0-00	10
202194-0-10	10	202922-0-10	6A	204768-0-10	1	205011-0-10	13	206356-4-00	3	206559-0-00	12	206623-2-11	10
202214-0-10	3-10	202973-0-10	6A	204769-0-10	8-8A	205013-2-11	13	206364-4-00	3	206560-0-00	12	206625-0-00	10
202225-0-10	4-4A	203187-0-10	10	204770-0-10	1	205021-0-10	10	206410-3-00	7	206564-0-00	12	206626-3-00	10
202227-0-11	4	203457-0-10	4-4A	204771-0-10	1	205024-0-10	11	206413-3-00	7A	206565-0-00	12	206628-0-00	1
202228-0-10	4-4A	203630-0-10	4-4A	204773-0-10	8-8A	205025-0-10	13	206415-4-00	7	206566-0-00	12	206629-0-00	1-10
202229-0-10	4-4A	203635-0-10	4-4A	204776-0-10	8-8A	205042-0-11	10	206419-4-00	7A	206567-0-00	12	206630-0-00	10
202256-0-10	4-4A	203647-2-11	4	204778-3-10	8-8A	205049-0-10	4	206429-4-00	9	206568-0-01	12	206632-2-00	10
202257-0-10	4-4A	203759-0-10	13-14-15	204781-0-10	1	205051-2-11	4	206431-4-00	9	206569-0-00	12	206633-0-00	10
202258-0-10	4-4A	203760-0-10	13	204787-0-10	8-8A	205052-2-11	4	206433-4-00	9A	206570-0-00	12	206634-0-00	10
202260-0-10	4-4A	203783-0-10	13-14-15	204789-0-10	8-8A	205055-0-10	4	206447-4-01	10	206572-4-00	11-11A	206635-0-00	10
202282-0-10	4-4A	203784-0-10	13	204798-0-20	1	205059-0-10	13	206506-0-00	9-9A	206574-2-00	11-11A	206636-0-00	10
202352-2-11	5-5A	204033-0-10	13-14-15	204799-0-10	11-11A	205060-0-10	13	206507-0-00	5-5A	206578-2-00	5-5A	206637-0-00	10
202371-0-10	1	204122-0-10	5-5A	204800-0-10	8-8A	205064-0-10	13	206508-0-00	5-5A	206580-2-00	6	206639-0-00	10
202385-0-10	6-6A	204647-3-10	8	204803-0-10	5	205065-0-10	13	206509-3-00	12	206582-3-00	6	206640-0-01	10
202386-0-10	5-5A	204659-0-10	8-8A	204846-0-10	14	205070-3-11	13	206510-4-00	12	206583-0-00	6	206642-0-00	10-12
202391-0-10	10	204671-0-10	7-7A	204850-0-10	14	205118-3-11	13	206514-0-00	9-9A	206584-2-00	6	206643-0-00	5-5A
202393-0-10	2	204674-3-10	8	204851-0-11	14	205125-0-00	8	206515-0-00	9-9A	206585-0-00	6A	206644-2-00	10
202398-0-10	2	204675-0-10	14	204855-4-10	8	205449-0-10	4A	206516-0-00	9	206586-0-00	6-6A	206645-4-00	7-7A
202408-0-10	6-6A	204676-0-10	13-14	204861-0-10	13-14	206042-0-10	15	206518-0-00	9-9A	206587-0-00	6-6A	206646-0-00	7

Part. N.	Tav. N.	Part. N.	Tav. N.	Part. N.	Tav. N.	Part. N.	Tav. N.	Part. N.	Tav. N.	Part. N.	Tav. N.	Part. N.	Tav. N.
206647-0-00	7A	206733-0-00	3	206833-4-00	9	701104-0-00	12	721424-2-00	4-4A	740230-2-00	2	745800-2-00	3-5-5A-7
206648-0-00	7A	206734-2-00	3	206839-4-00	9A	701113-0-00	7-7A-12	721433-2-00	2	741230-2-00	4A		7A-8-8A
206651-0-00	1	206735-0-00	3	206847-0-00	1	701116-0-00	5-5A	721435-2-00	3	741400-0-00	4-4A		9-9A
206652-2-00	7	206736-2-00	12	206854-3-00	1	701133-0-00	5-5A	721443-2-00	6-6A	741413-0-00	6-6A-13	745803-2-00	4-4A
206653-2-00	7A	206739-0-00	12	206856-0-00	1	701151-0-00	12	721464-2-00	3-5-6-6A		14-15	745812-2-00	6-6A-7-7A
206656-0-00	7-7A	206740-0-00	1	206857-0-00	3	701405-0-00	4		10-12	741431-0-00	13-14-15		8-8A-9-9A
206658-2-00	7	206742-4-00	12	206858-0-00	3	702412-0-00	8-8A	721474-2-00	12	741433-0-00	10		10-12
206659-2-00	7-7A	206743-3-00	12	206860-0-00	5-5A	703005-0-00	18-19	721475-2-00	17	741520-0-10	11	746007-2-00	2-3-10
206665-2-00	12	206744-0-00	2	206871-4-01	6	703007-0-00	5-5A	721484-2-00	12	741535-0-00	4-4A-11A	746008-0-00	6
206666-0-00	12	206746-0-00	4-4A	206872-0-00	6-6A	703210-0-00	9-9A	721494-2-00	10	741539-0-00	4-4A	746020-2-00	10
206667-0-00	12	206747-0-01	4-4A	206876-0-10	4	704009-4-00	17	721514-0-00	1	741546-2-00	6-6A	746208-2-00	3
206669-2-00	12	206748-0-00	1	206880-2-00	3	704302-4-00	4A	721525-0-00	5-5A	741559-2-00	4-4A	746402-0-00	17
206679-0-00	5-5A	206750-0-00	12	206885-2-00	3	704345-2-00	17	722431-2-00	18-19	741657-0-00	4-4A	746408-2-00	7-7A
206681-0-00	5-5A	206751-0-00	12	206929-0-00	4A	704346-2-00	17	722442-2-00	12	741682-0-00	3-4-4A	746409-2-00	17
206682-0-00	1	206752-0-00	12	206948-2-00	3	704409-0-00	11-11A-17	722471-2-00	11-11A	741724-0-00	3	765200-6-11	9-16
206683-0-00	5-5A	206753-0-00	12	206987-0-00	4A	704424-2-00	17	722481-2-00	12	741745-2-00	6-6A	765200-6-12	9A-16
206684-0-00	5-5A	206754-0-00	4-4A	206989-4-00	8A	704536-0-00	17	722905-2-00	17	741956-2-00	3-5-5A	765200-6-90	9-14-16
206685-0-00	3	206755-0-00	4-4A	206990-0-00	8A	704802-0-00	11-11A	722917-2-00	17	742068-2-00	17	778202-0-00	7-7A
206686-0-00	7-7A	206756-0-00	3	206994-2-00	5A	704808-0-00	6	724032-0-00	6-6A	742222-2-00	6-6A	778203-0-00	9-9A-10
206687-2-00	3	206757-0-00	11-11A	206995-0-00	4A	704813-0-00	8-8A-12		9-9A	742457-2-00	11-11A	778208-0-00	7-7A
206688-0-00	3	206758-0-10	11-11A	206997-4-00	4A	704829-0-00	6-6A	724422-2-00	4-4A	742758-0-00	11-11A	778236-0-00	7-7A
206689-0-00	5-5A	206763-0-00	3	206998-4-00	6A	704837-0-00	9-9A	724895-2-00	3	743243-2-00	5-5A	778400-0-00	9-9A
206690-2-00	5-5A	206764-0-00	3	207003-2-00	13-14-15	704841-0-00	6-6A	727002-0-00	7-7A	743471-2-00	5-5A	778401-0-00	7-7A
206692-0-00	5-5A	206767-0-00	3	207004-2-00	13-14-15	704845-0-00	7	727096-0-00	10	744332-2-00	6-6A-9	778407-0-00	9-9A
206693-0-00	5-5A	206768-0-00	3	207020-2-01	13-14	704847-0-00	7-7A	727203-0-00	5-5A		9A-10	778408-0-00	8-8A
206695-0-00	7-7A	206769-0-10	3	207021-2-01	15	705008-0-00	6-6A	727706-0-00	9-9A	744334-2-00	6-6A-9-9A	778417-0-00	6-6A-7-7A
206697-4-01	5-5A	206770-0-00	3	208371-0-10	1	705013-0-00	4-4A-7-7A	728272-0-00	6-6A		10-11-11A	778421-0-00	8-8A
206699-0-01	5-5A	206790-2-00	6-6A	300218-0-10	4-4A	705029-0-00	9-9A	729011-2-00	4-4A	744530-0-00	8-8A	778431-0-00	5-5A
206704-3-00	5-5A	206794-0-00	6-6A	301586-0-10	10		11-11A	729032-2-00	6-6A	744573-0-00	11-11A	778520-0-00	10
206708-0-00	5-5A	206795-0-00	6-6A	302172-0-10	4A	705201-0-00	6-6A	729034-2-00	18-19	744621-0-00	6-6A	778832-0-00	1-11-11A
206711-0-00	4-4A	206796-0-00	6-6A	700205-0-00	17	705208-0-00	6	729051-2-00	6-6A-10	744631-2-00	4-4A	778837-0-00	9-9A
206713-2-00	4-4A	206797-0-00	6-6A	700207-0-00	6-6A	705230-0-00	6-6A	729054-2-00	18-19	744654-2-00	3	781310-0-20	3
206714-2-00	4-4A	206798-0-00	6-6A	700208-0-00	8-8A	705408-0-00	6	730023-2-00	3	744742-0-00	2	781312-0-20	3
206715-0-00	2	206799-0-00	6-6A	700630-0-00	5-5A	705925-0-00	3	731107-0-00	18-19	745001-0-00	9-9A	781324-0-20	3
206716-0-00	2	206803-2-00	6	701002-0-00	6-6A	705957-0-00	2	733008-2-00	17	745002-0-00	4-4A-7	788001-0-01	4-4A
206722-2-00	2	206804-0-00	6	701004-0-00	12	705977-0-00	12	733503-0-00	4-4A		7A-9-9A	900201-0-10	17
206723-4-00	2	206805-0-00	6A	701005-0-00	12	720431-2-00	4-4A-	733505-2-00	4-4A-10	745114-0-00	10	900203-0-10	17
206725-2-00	2	206807-2-00	6A	701006-0-00	10	720464-4-00	17	733507-0-00	12-17	745124-0-00	8-8A	900204-0-10	17
206726-0-00	2	206809-4-00	10	701007-0-00	6-6A	720505-4-00	17	733508-2-00	17-18-19	745125-2-00	6-6A	900694-0-11	17
206727-0-00	2	206812-0-00	4-4A	701032-0-00	12	720545-4-00	17	733510-4-00	17	745126-2-00	2	900918-0-00	17
206730-0-10	3	206827-4-00	9	701050-0-00	12	720566-2-00	17	740220-2-00	6-6A	745168-0-00	7-7A	900920-0-00	17

Part. N.	Tav. N.	Part. N.	Tav. N.	Part. N.	Tav. N.	Part. N.	Tav. N.	Part. N.	Tav. N.	Part. N.	Tav. N.	Part. N.	Tav. N.
900925-4-01	17	991102-2-00	19										
900926-0-00	17	991106-0-00	18										
900927-0-00	17	991107-0-00	18-19										
900928-0-00	17	991108-2-00	19										
900929-0-01	17	991110-0-00	19										
900931-0-00	17	991111-0-00	18-19										
901101-0-00	17	991112-0-00	18-19										
901102-0-00	17	991113-0-00	18-19										
901103-0-00	17	991114-0-00	18-19										
901104-0-00	17	991115-3-00	19										
901105-0-00	17	991119-4-00	19										
901120-2-00	17	991128-0-00	18-19										
990074-1-10	16	991135-6-00	18										
990174-0-10	16	991136-4-00	18										
990176-0-10	16	991137-2-00	18										
990179-4-11	17	991139-3-00	19										
990180-0-10	16	991140-2-00	18										
990181-0-10	16	991144-3-00	18-19										
990182-0-10	16	991160-5-00	19										
990183-0-12	16	991162-0-00	19										
990310-0-10	17	991163-0-00	19										
990311-0-10	17	991164-4-00	19										
990314-0-00	17	991165-0-00	19										
990316-0-10	17	991166-2-00	19										
990324-0-10	16	991168-0-00	19										
990325-0-10	16	991179-0-00	18-19										
990327-0-10	16	991186-0-00	17										
990474-0-10	16	991187-0-00	17										
990577-0-10	16	991188-0-00	17										
990585-0-10	16	991189-0-00	17										
990622-0-10	16												
990624-0-00	16												
990639-0-10	16												
990685-0-10	16												
990981-0-00	17												
990982-0-00	17												
990983-0-00	17												
990984-4-00	17												
990985-0-00	16												
990986-4-00	17												
990987-4-00	17												

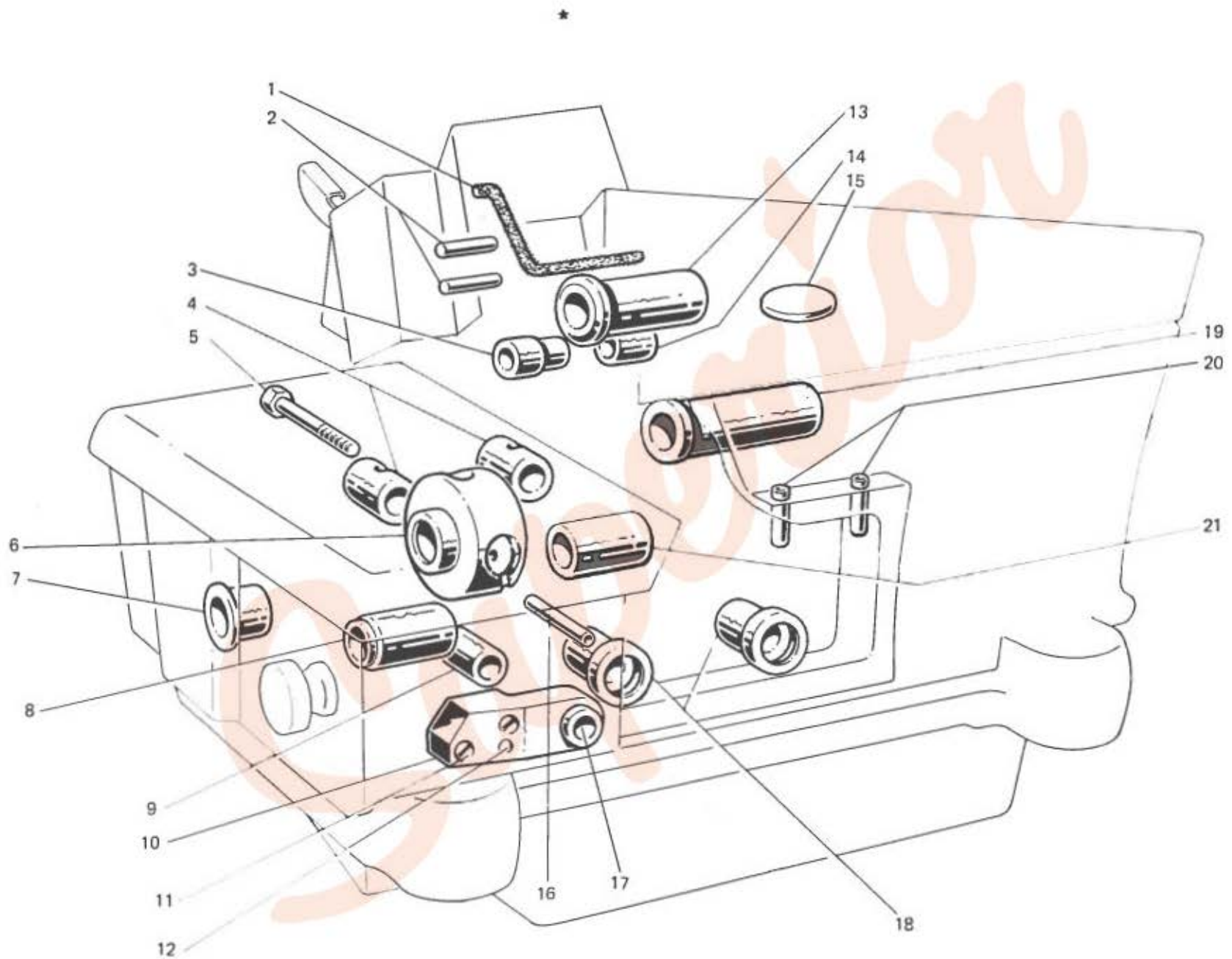

Fig. N. Abb. N.	Part. N. Bestell N. Piece N. Pieza N.	Q. C. Arzaki	DESCRIZIONE	DESCRIPTION	BENENNUNG	DESCRIPTION	DESCRIPCION
★	206854-3-00	1	base con bussole e guidafile	base assembly			
1	778832-0-00	1	stoppino	wick			
2	202371-0-10	2	spina	pin			
3	206628-0-00	1	bussola	bush			
4	206651-0-00	2	bussola posteriore	rear bush			
5	204798-0-20	1	vite	screw			
6	206682-0-00	1	bussola intermedia	intermediary bush			
7	206595-0-00	1	bussola sinistra	left bush			
8	204768-0-10	1	bussola	bush			
9	204771-0-10	1	bussola	bush			
10	206856-0-00	1	blocchetto	block			
11	721514-0-00	2	vite	screw			
12	208371-0-10	1	spina	pin			
13	206538-0-00	1	bussola	bush			
14	206629-0-00	1	bussola destra	right bush			
15	206748-0-00	1	tappo ad espansione	plug			
16	204781-0-10	1	tubetto	pipe			
17	204770-0-10	1	bussola	bush			
18	202065-0-10	2	bussola anteriore	front bush			
19	206539-0-00	1	bussola	bush			
20	206740-0-00	2	passafilo	thread guide			
21	206594-0-00	1	bussola	bush			

Superior

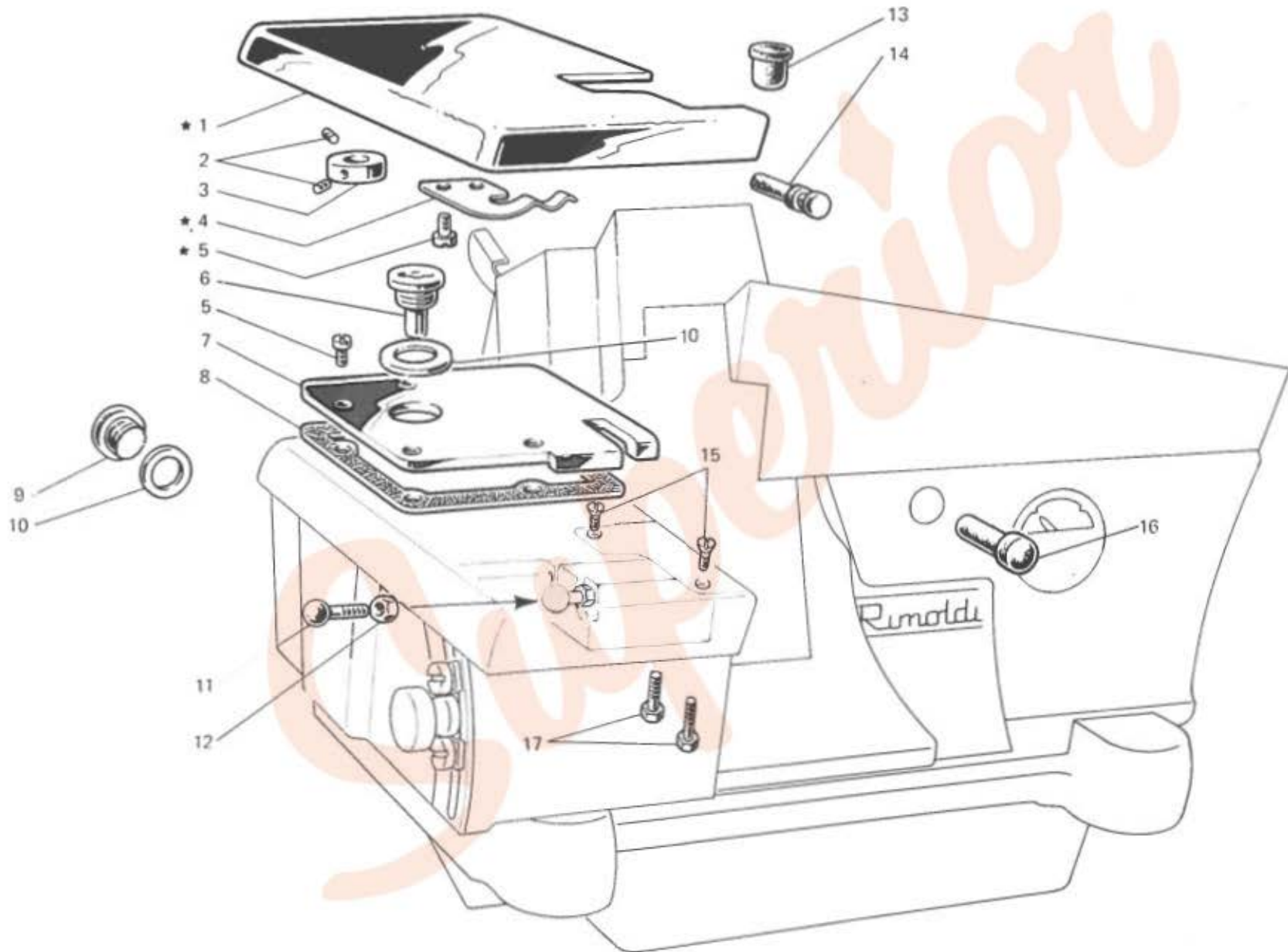

Fig. N. Abb. N.	Part. N. Bestell N. Pieze N. Pieza N.	Qt. Anzahl	DESCRIZIONE	DESCRIPTION	BENENNUNG	DESCRIPTION	DESCRIPTION
★	206723-4-00	1	piano di lavoro completo	working assembly			
1	206722-2-00	1	piano di lavoro	working plate			
2	745126-2-00	2	vite	screw			
3	202393-0-10	1	anello	ring			
4	206716-0-00	1	molla	spring			
5	721433-2-00	6	vite	screw			
6	206727-0-00	1	tappo carico olio	plug			
7	206725-2-00	1	coperchio cinematismo	cover			
8	206726-0-00	1	guarnizione	gasket			
9	202026-0-10	1	tappo	plug			
10	705957-0-00	2	rondella cartone	washer			
11	206715-0-00	1	vite testa sferica	screw			
12	746007-2-00	1	dado	nut			
13	206744-0-00	1	tampone	pad			
14	206534-0-00	1	tappo	plug			
15	744742-0-00	2	vite per placca ago	screw for needle plate			
16	202398-0-10	1	tappo	plug			
17	740230-2-00	2	vite fissa salvo ago e spingi asola	screw for rear and front needle guard			

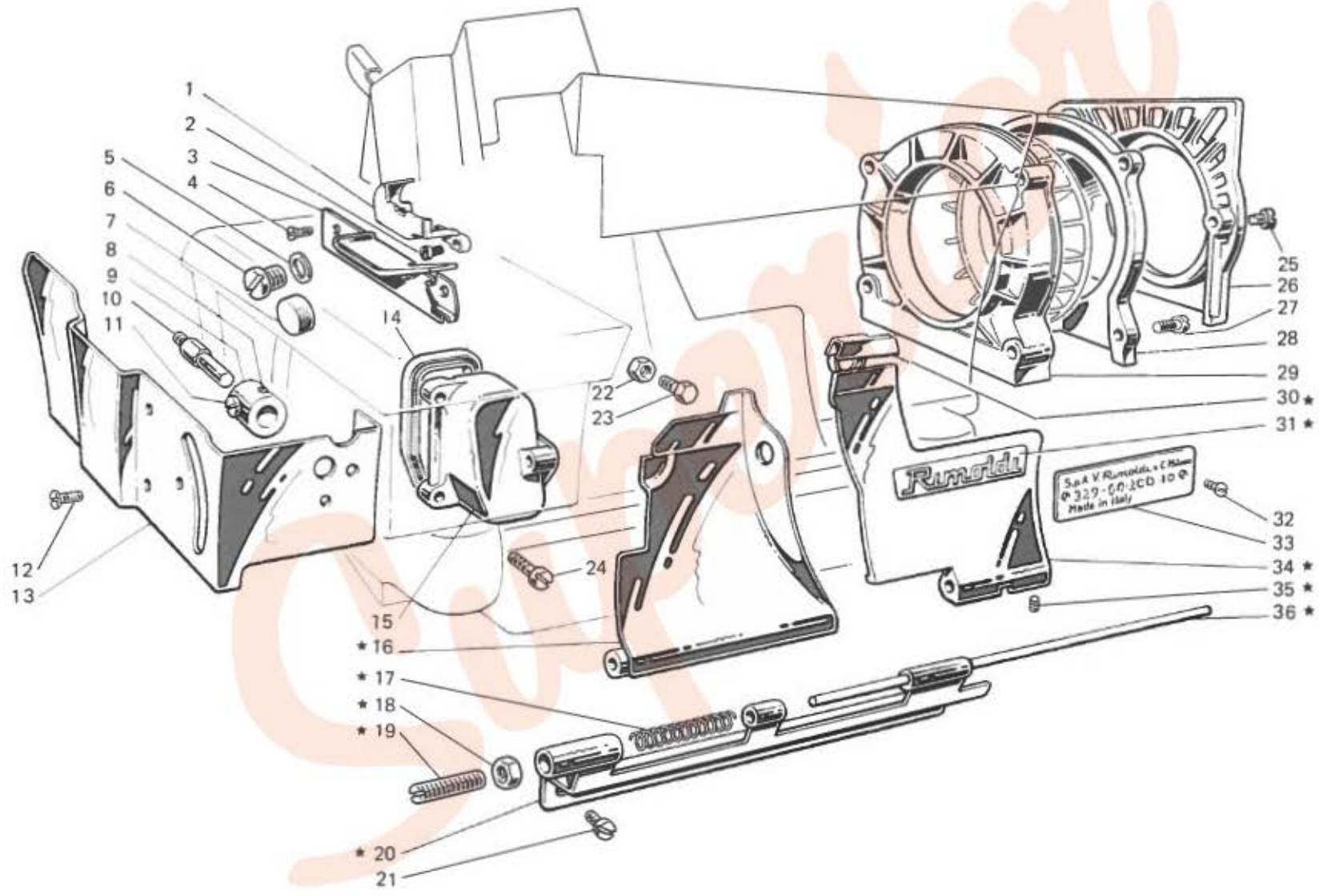

Fig. N. Abb. N.	Part. N. Bestell N. Piece N. Pieza N.	Qt. Anzahl	DESCRIZIONE	DESCRIPTION	BENENNUNG	DESCRIPTION	DESCRIPCION
★	206356-4-00	1	sportello ant. compl.	front cover assembly			
1	206730-0-10	1	vaschetta recupero olio	sump			
2	741956-2-00	1	vite	screw			
3	206735-0-00	1	carterino para olio	oil retainer			
4	744654-2-00	3	vite	screw			
5	705925-0-00	1	rondella in fibra	washer			
6	202480-0-10	1	tappo	plug			
7	202027-0-10	1	tappo	plug			
8	730023-2-00	1	vite	screw			
9	206734-2-00	1	morsetto fiss.carter laterale	side cover clamp			
10	206733-0-00	1	vite per carter laterale	screw			
11	721435-2-00	1	vite	screw			
12	724895-2-00	4	vite	screw			
13	206880-2-00	1	carter laterale completo	side cover assembly			
14	206858-0-00	1	guarnizione	gasket			
15	206857-0-00	1	carterino	cover			
16	206885-2-00	1	sportello scorrevole	sliding cover			
17	206768-0-00	1	molla	spring			
18	746208-2-00	1	dado	nut			
19	206769-0-10	1	vite di regolazione	adjusting screw			
20	206756-0-00	1	cerniera	clamp			
21	741724-0-00	4	vite	screw			
22	746007-2-00	1	dado	nut			
23	202214-0-10	1	vite	screw			
24	741682-0-00	2	vite	screw			
25	721464-2-00	2	vite per coperchio	screw			
26	206685-0-00	1	coperchio cinghia	cover			
27	202484-0-10	4	vite	screw			
28	206687-2-00	1	coperchio coclea	scroll cover			
29	206688-0-00	1	coclea per ventola	scroll			
30	206764-0-00	1	zoccolo	block			
31	206770-0-00	1	targhetta Rimoldi	Rimoldi plate			
32	202165-0-10	2	vite	screw			
33	781310-0-20	1	targhetta classe	head class plate			
34	206763-0-00	1	sportello ribaltabile	tipping cover			
35	745800-2-00	1	vite	screw			
36	206767-0-00	1	perno	pin			
			VARIANTE PER 329-00-2CD-12	VARIANTE PER 329-00-2CD-12			
33	781312-0-20	1	targhetta classe	head class plate			
			VARIANTE PER 329-00-3MU-01	VARIANTE PER 329-00-3MU-01			
★	206364-4-00	1	sportello ant. compl.	front cover assembly			
16	206948-2-00	1	sportello scorrevole	sliding cover			
33	781324-0-20	1	targhetta classe	head class plate			

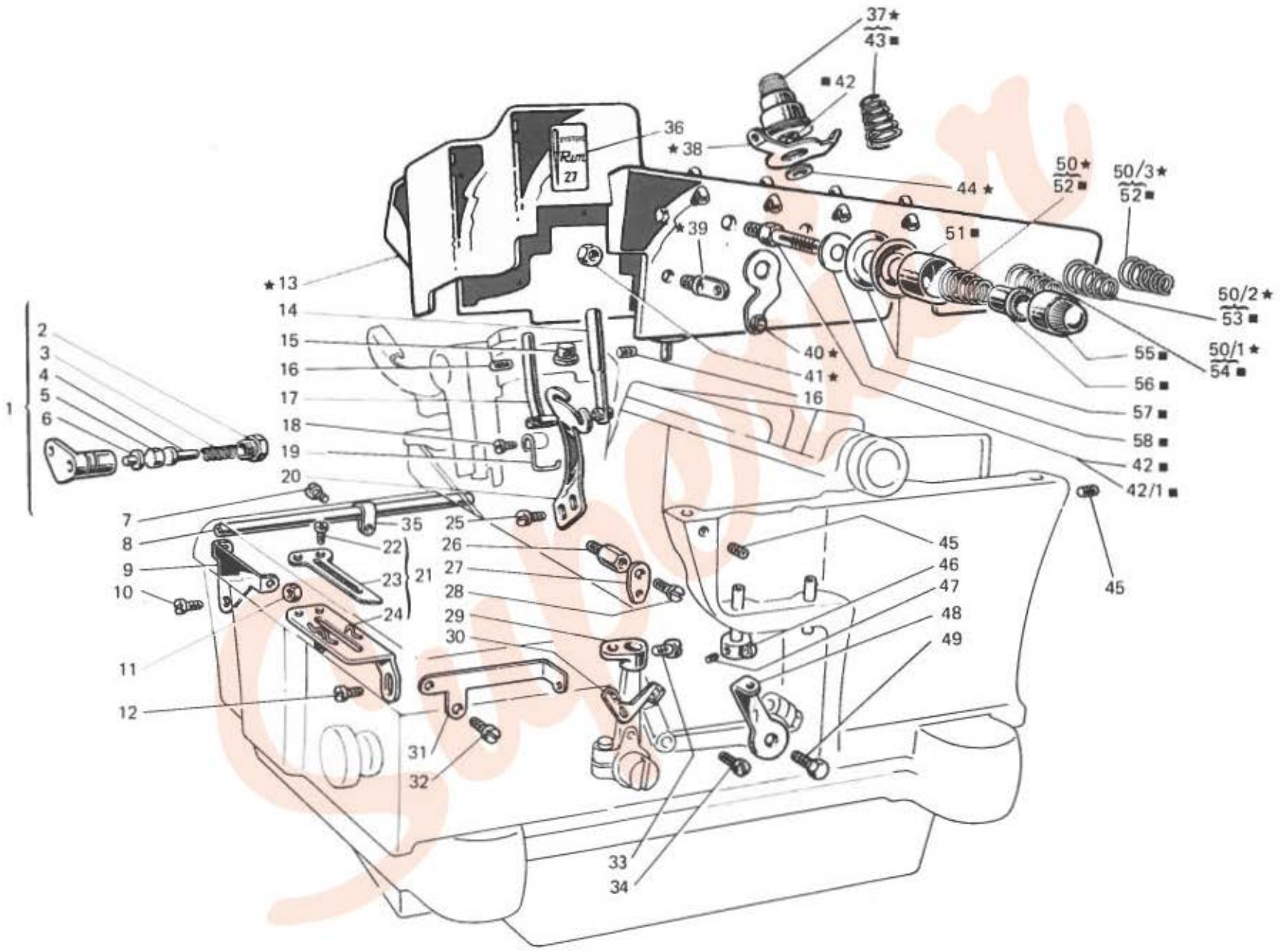

Fig. N. Abb. N.	Part. N. Bestell N. Piece N. Pieza N.	Qt. Anzahl	DESCRIZIONE	DESCRIPTION	BENENNUNG	DESCRIPTION	DESCRIPCION
*	206257-4-00	1	coperchio superiore completo	upper cover assembly			
1	205051-4-11	1	passafilo completo dell'ago	thread guide assembly			
2	202260-0-10	1	tappo filettato	plug			
3	202257-0-10	1	molla	spring			
4	202258-0-10	1	pernetto	pin			
5	205049-0-10	1	pastiglia	plug			
6	202256-0-10	1	pernetto	pin			
7	741559-2-00	1	vite	screw			
8	204704-0-10	1	tubetto	tube			
9	204747-0-10	1	passafilo	thread guide			
10	724422-2-00	1	vite	screw			
11	733505-2-00	1	dado	nut			
12	721424-2-00	2	vite	screw			
13	206317-3-00	1	coperchio con passafili	cover with thread guide			
14	206714-2-00	1	passafilo	thread guide			
15	206746-0-00	1	tampone	pad			
16	729011-2-00	2	vite	screw			
17	205052-2-11	1	passafilo dell'ago	needle thread guide			
18	741535-0-00	1	vite	screw			
19	205055-0-10	1	cavallotto guida fili	coupling			
20	206535-0-00	1	tendifilo dell'ago	needle thread guide			
21	204760-4-10	1	mensola completa	bracket assembly			
22	701405-0-00	2	vite	screw			
23	204761-0-10	1	mensola premi filo	bracket			
24	204759-2-10	1	mensola con spine	bracket with pin			
25	741539-0-00	2	vite	screw			
26	206755-0-00	1	colonnina per passafilo	column			
27	206812-0-00	1	passafilo crochet inferiore	upper looper thread guide			
28	744631-2-00	1	vite	screw			
29	204750-0-10	1	squadretta	bracket			
30	204911-0-11	1	tendifilo	thread guide			
31	206876-0-00	1	passafilo	thread guide			
32	741682-0-00	1	vite	screw			
33	741400-0-00	1	vite	screw			
34	741657-0-00	1	vite	screw			
35	204756-0-10	1	fascetta	collar			
36	788001-0-01	1	decalcomania sist.aghi R1M 27	needle Rim 27 decalcomania			
37	206340-4-00	1	tensione compl.con molla fig.43	tension assembly with spring fig.43			
38	203630-0-10	1	passafilo	thread guide			
39	206711-0-00	3	passafilo	thread guide			
40	206713-2-00	1	passafilo	thread guide			
41	733503-0-00	3	dado	nut			
42	202225-0-11	2	perno per tensione fig.50-37	pin for tension fig.50-37			
42/1	206747-0-01	3	perno per ten.fig.50/1-50/2-50/3	pin for tension fig.50/1-50/2-50/3			
43	203457-0-10	1	molla per tensione fig.37	spring for tension fig. 37			
44	705013-0-00	1	rondella	washer			
45	745803-2-00	3	vite	screw			

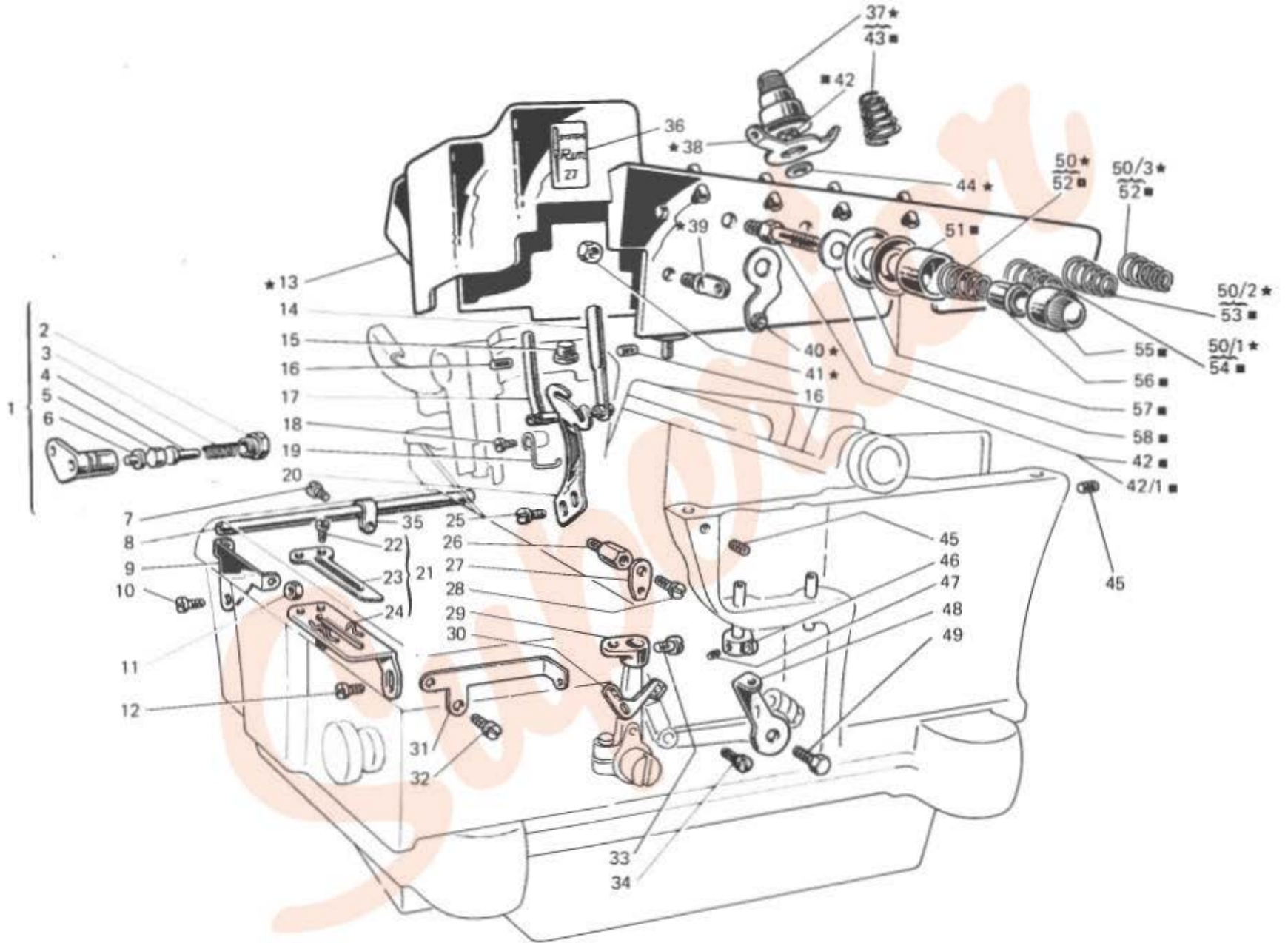

Fig. N. Abb. N.	Part. N. Bestell N. Pieza N.	Qt. Anzahl	DESCRIZIONE	DESCRIPTION	BENENNUNG	DESCRIPTION	DESCRIPCION
46	202282-0-10	1	tendifilo	thread guide			
47	745002-0-00	1	vite	screw			
48	202683-0-10	1	tendifilo crochet infer.	thread guide lower looper			
49	720431-2-00	1	vite	screw			
50	206346-4-00	1	tensione completa	tension assembly			
50/1	206342-4-00	1	tensione completa	tension assembly			
50/2	206343-4-00	1	tensione completa	tension assembly			
50.3	206341-4-00	1	tensione completa	tension assembly			
51	202556-0-00	5	scodellino	cap			
52	202227-0-10	2	molla per tensione fig.50-50/3	spring for tension fig.50-50/3			
53	202681-0-10	1	molla per tensione fig.50/2	spring for tension fig.50/2			
54	202228-0-10	1	molla per tensione fig.50/1	spring for tension fig.50/1			
55	202558-2-00	5	pomolo	knob			
56	202229-0-10	5	bussola	bush			
57	300218-0-10	10	disco per tensione	tension disc			
58	206754-0-00	5	rondella	washer			
			VARIANTE PER 329-00-2CD-12	VARIATION FOR 329-00-2CD-12			
1	204748-4-11	1	pressafilo completo dell'ago	thread guide assembly			
5	203635-0-10	2	pastiglia	plug			
17	203647-2-11	1	passafilo dell'ago	needle thread guide			
19	204753-0-10	1	cavallotto guida fili	coupling			

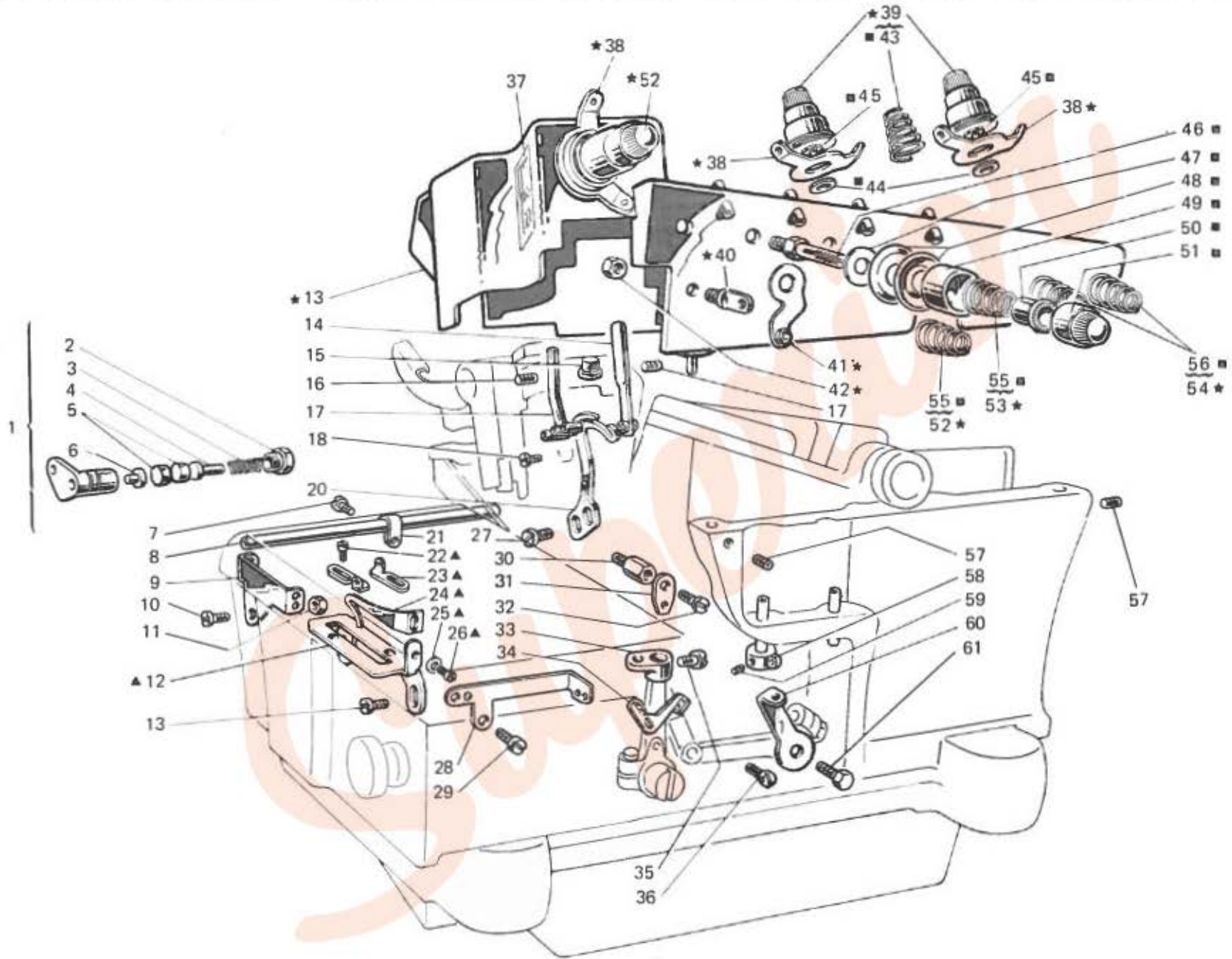

Fig. N. Abb. N.	Part. N. Bestell N. Piece N. Pieza N.	Qt. Anzahl	DESCRIZIONE	DESCRIPTION	BENENNUNG	DESCRIPTION	DESCRIPCION
★	206260-4-00	1	coperchio superiore completo	upper cover assembly			
1	206060-4-01	1	passafilo completo dell'ago	thread guide assembly			
2	202260-0-10	1	tappo filettato	plug			
3	202257-0-10	1	molla	spring			
4	202258-0-10	1	pernetto	pin			
5	203635-0-10	2	pastiglia	plug			
6	202256-0-10	1	pernetto	pin			
7	741559-2-00	1	vite	screw			
8	204704-0-10	1	tubetto	tube			
9	205449-0-10	1	passafilo	thread guide			
10	724422-2-00	1	vite	screw			
11	733505-2-00	1	dado	nut			
12	206997-4-00	1	mensola completa	bracket assembly			
13	721424-2-00	2	vite	screw			
14	206320-3-00	1	coperchio con passafili	cover with thread guide			
15	206714-2-00	1	passafilo	thread guide			
16	206746-0-00	1	tampone	pad			
17	729011-2-00	2	vite	screw			
18	206057-2-01	1	passafilo dell'ago	needle thread guide			
19	741535-0-00	1	vite	screw			
20	206987-0-00	1	tendifilo dell'ago	needle thread tension			
21	204756-0-10	1	fascetta	collar			
22	100458-0-10	2	vite	screw			
23	302172-0-10	2	passafilo	thread guide			
24	206995-0-00	1	piastrina	plate			
25	704302-4-00	1	rondella	washer			
26	741230-2-00	1	vite	screw			
27	741539-0-00	2	vite	screw			
28	206929-0-00	1	passafilo	thread guide			
29	741682-0-00	1	vite	screw			
30	206755-0-00	1	colonnina per passafilo	column for thread guide			
31	206812-0-00	1	passafilo crochet	looper thread guide			
32	744631-2-00	1	vite	screw			
33	204750-0-10	1	squadretta	bracket			
34	204911-0-11	1	passafilo	thread guide			
35	741400-0-00	1	vite	screw			
36	741657-0-00	1	vite	screw			
37	788001-0-01	1	decalcomania sist. aghi Rim27	needle Rim27 system decalcomania			
38	203630-0-10	3	passafilo	thread guide			
39	206340-4-00	2	tensione completa	tension assembly			
40	206711-0-00	3	passafilo	thread guide			
41	206713-2-00	1	passafilo	thread guide			
42	733503-0-00	3	dado	nut			
43	203457-0-10	2	molla per tensione fig.39	spring for tension fig.39			
44	705013-0-00	2	rondella	washer			
45	202225-0-11	4	perno per tensione fig.39 e 52	pin for tension fig.39 and 52			
46	206747-0-01	3	perno per tensione fig. 53 e 54	pin for tension fig.53 and 54			

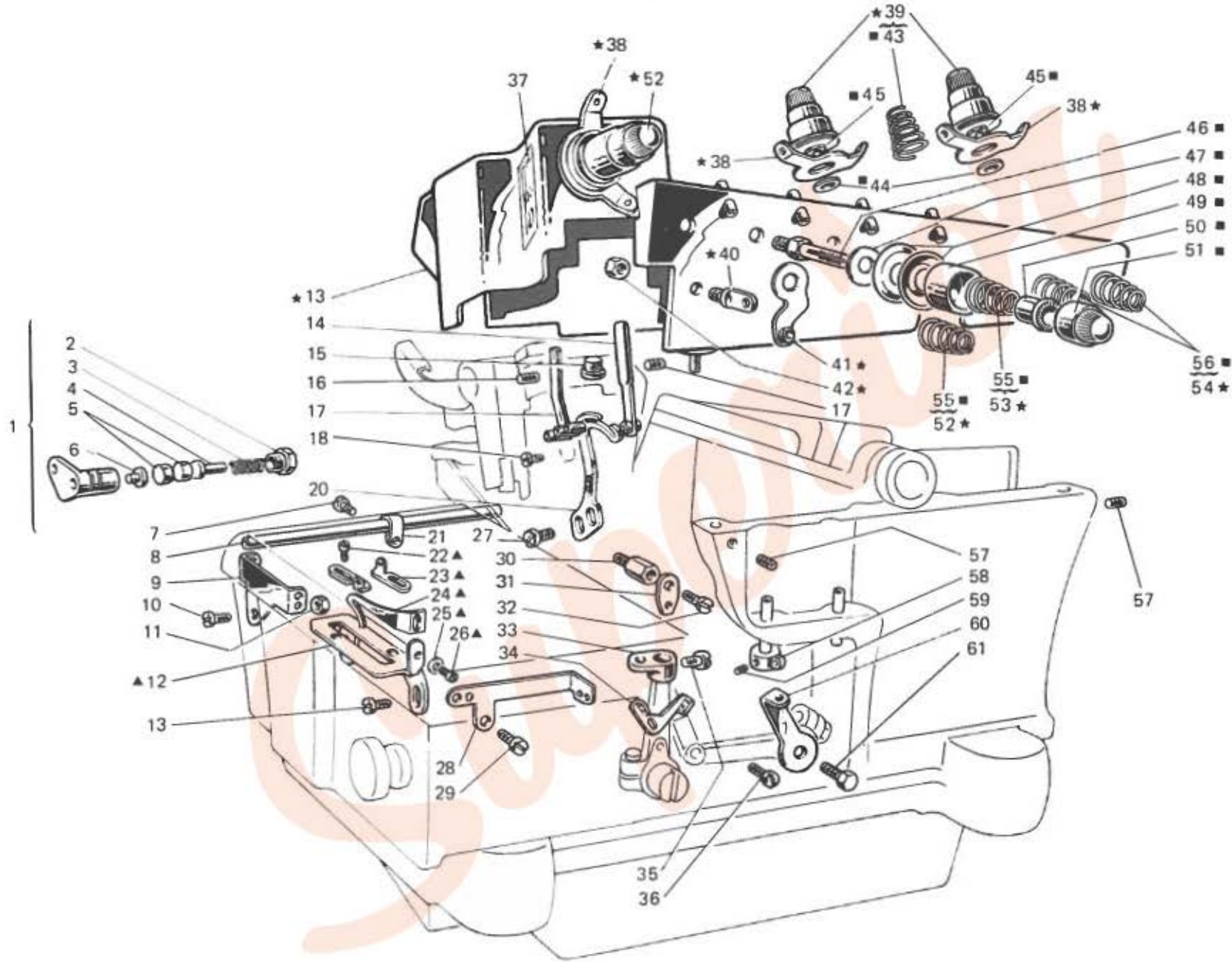

Fig. N. Abb. N.	Part. N. Bestell N. Piece N. Pieza N.	Qt. Anzahl	DESCRIZIONE	DESCRIPTION	BENENNUNG	DESCRIPTION	DESCRIPCION
47	206754-0-00	7	rondella	washer			
48	300218-0-10	14	disco per tensione	disc for tension			
49	202556-0-00	7	scodellino	cap			
50	202229-0-10	7	bussola	bush			
51	202558-2-00	7	pomolo	knob			
52	206347-4-00	2	tensione completa	tension assembly			
53	206342-4-00	1	tensione completa	tension assembly			
54	206343-4-00	2	tensione completa	tension assembly			
55	202228-0-10	3	molla per tensione fig. 52 e 53	spring for tension fig.52 and 53			
56	202681-0-10	2	molla per tensione fig. 54	spring for tension fig.54			
57	745803-2-00	3	vite	screw			
58	202282-0-10	1	passafilo	thread guide			
59	745002-0-00	1	vite	screw			
60	202683-0-10	1	ten difilo crochet	thread tension looper			
61	720431-2-00	1	vite	screw			

Superior

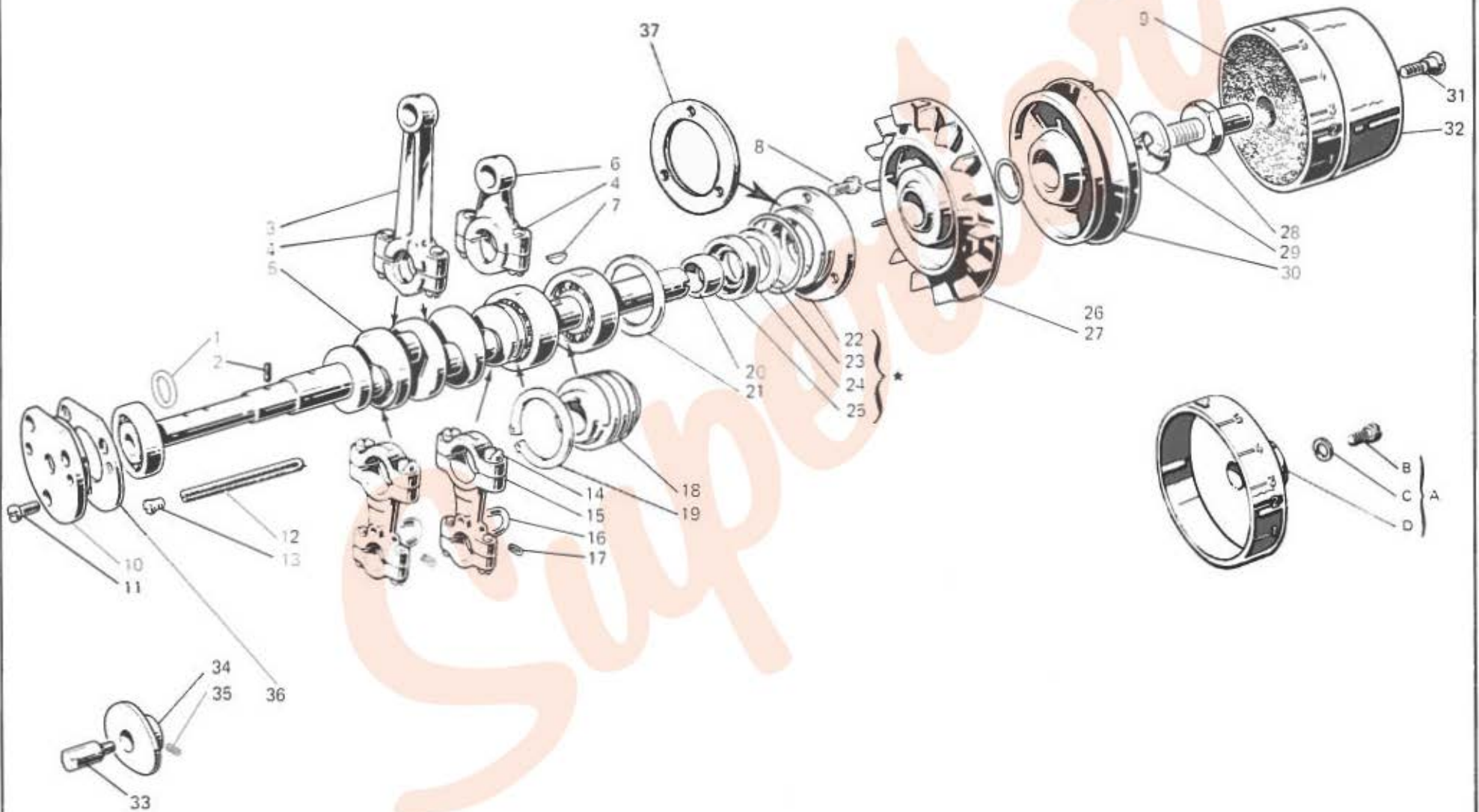

Fig. N. Abb. N.	Part. N. Bestell N. Piece N. Pieza N.	Qt. Anzahl	DESCRIZIONE	DESCRIPTION	BENENNUNG	DESCRIPTION	DESCRIPCION
*	206697-4-01	1	gruppo flangia con anelli	flange with ring			
1	206532-0-00	1	rondella	washer			
2	206708-0-00	1	stoppino	wick			
3	206549-2-00	1	biella albero sup.con vite	connecting rod with screw			
4	743471-2-00	4	vite	screw			
5	206704-3-00	1	albero principale con cuscinetti	main shaft with bearings			
6	206578-2-00	1	biella comando alb.coltello sup.	connecting rod for upper knife			
7	204122-0-10	1	chiavetta	key			
8	721464-2-00	3	vite	screw			
9	206507-0-00	1	tampone per volantino	pad			
10	206860-0-00	1	flangia sinistra	left flange			
11	741956-2-00	3	vite	screw			
12	778431-0-00	1	stoppino	wick			
13	206681-0-00	1	tappo	plug			
14	743243-2-00	8	vite	screw			
15	202071-2-10	2	biella con viti	connecting rod with screw			
16	206643-0-00	2	cavallotto per manicotto	coupling			
17	745800-2-00	2	vite	screw			
18	206556-0-00	1	vite senza fine	worm screw			
19	202386-0-10	1	anello elastico	spring ring			
20	206692-0-00	1	distanziale alb. principale	spacer			
21	206689-0-00	1	anello compensazione	ring			
22	206699-0-01	1	flangia	flange			
23	701133-0-00	1	anello di tenuta	retainer ring			
24	206693-0-00	1	rondella	washer			
25	700630-0-00	1	anello di tenuta	retainer ring			
26	701116-0-00	1	anello di tenuta	retainer ring			
27	206690-2-00	1	ventola di raffreddamento	cooling fan			
28	206683-0-00	1	perno per volantino	pin			
29	206684-0-00	1	chiavetta alb.princ.	key			
30	206508-0-00	1	volantino	pulley			
31	202492-0-10	1	vite	screw			
32	206679-0-00	1	coperchio volantino	pulley cover			
33	204757-0-11	1	perno porta camma	pin			
34	204803-0-10	1	camma tendifilo	cam thread guide			
35	727203-0-00	2	vite	screw			
36	206543-0-00	1	guarnizione	gasket			
37	206544-0-00	1	guarnizione	gasket			
A	202539-4-00	1	<u>SOLO A RICHIESTA</u> coperchio volantino Quick Stop	<u>ONLY ON REQUEST</u> pulley cover for Quick Stop			
B	721525-0-00	1	vite	screw			
C	703007-0-00	1	rondella	washer			
D	202352-2-11	1	coperchio	cover			

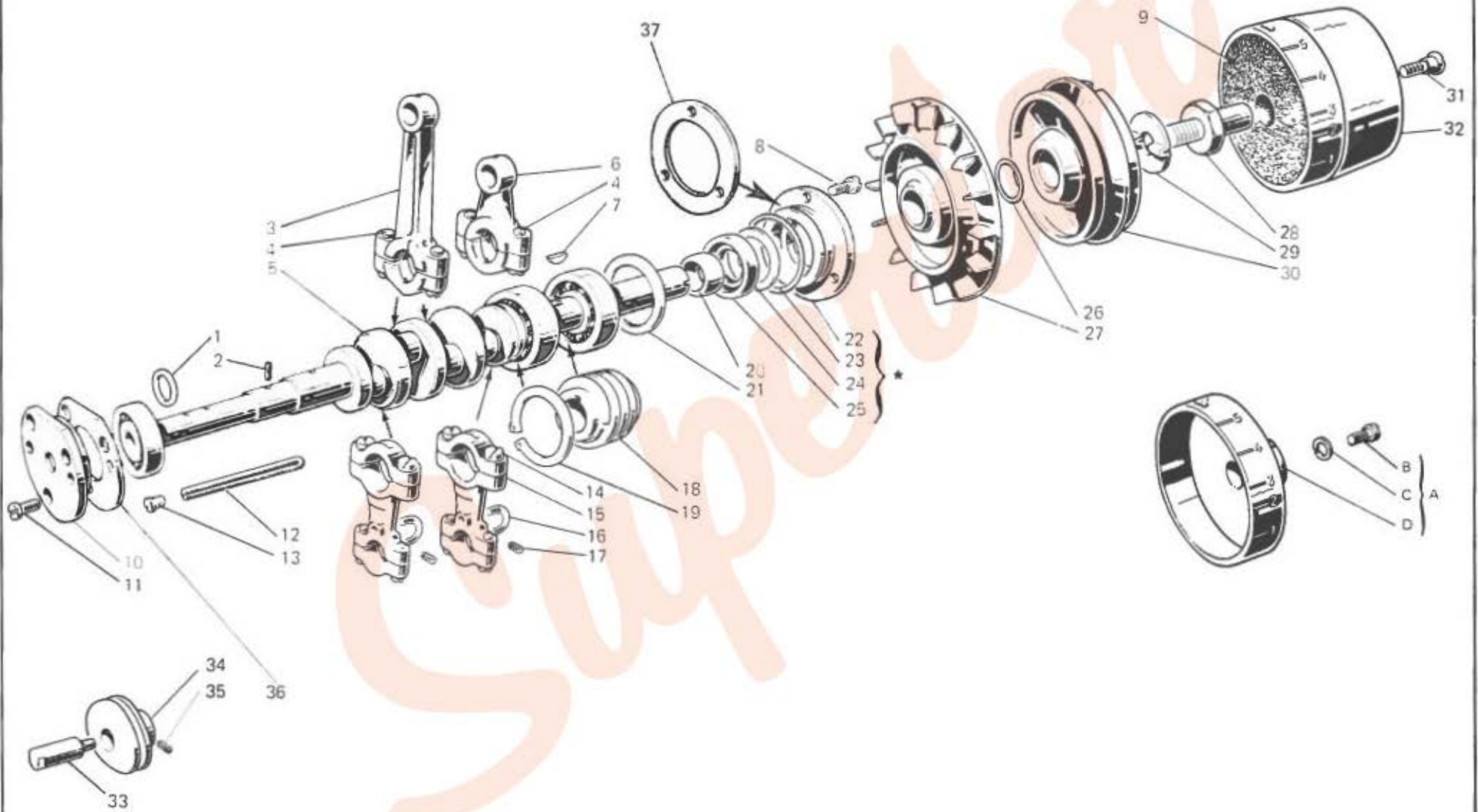

Fig. N. Abb. N.	Part. N. Bestell N. Piece N. Pieza N.	Qt. Anzahl	DESCRIZIONE	DESCRIPTION	BENENNUNG	DESCRIPTION	DESCRIPCION
★	206697-4-01	1	gruppo flangia con anelli	flange with ring			
1	206532-0-00	1	rondella	washer			
2	206708-0-00	1	stoppino	wick			
3	206549-2-00	1	biella albero sup.con vite	connecting rod with screw			
4	743471-2-00	4	vite	screw			
5	206704-3-00	1	albero principale con cuscinetti	main shaft with bearings			
6	206578-2-00	1	biella comando alb.coltello sup.	connecting rod for upper knife			
7	204122-0-10	1	chiavetta	key			
8	721464-2-00	3	vite	screw			
9	206507-0-00	1	tampone per volantino	pad			
10	206860-0-00	1	flangia sinistra	left flange			
11	741956-2-00	3	vite	screw			
12	778431-0-00	1	stoppino	wick			
13	206681-0-00	1	tappo	plug			
14	743243-2-00	8	vite	screw			
15	202071-2-10	2	biella con viti	connecting rod with screw			
16	206643-0-00	2	cavallotto per manicotto	coupling			
17	745800-2-00	2	vite	screw			
18	206556-0-00	1	vite senza fine	worm screw			
19	202386-0-10	1	anello elastico	spring ring			
20	206692-0-00	1	distanziale alb. principale	spacer			
21	206689-0-00	1	anello compensazione	ring			
22	206699-0-01	1	flangia	flange			
23	701133-0-00	1	anello di tenuta	retainer ring			
24	206693-0-00	1	rondella	washer			
25	700630-0-00	1	anello di tenuta	retainer ring			
26	701116-0-00	1	anello di tenuta	retainer ring			
27	206690-2-00	1	ventola di raffreddamento	cooling fan			
28	206683-0-00	1	perno per volantino	pin			
29	206684-0-00	1	chiavetta alb.princ.	key			
30	206508-0-00	1	volantino	pulley			
31	202492-0-10	1	vite	screw			
32	206679-0-00	1	coperchio volantino	pulley cover			
33	204757-0-11	1	perno porta camma	pin			
34	206994-2-00	1	camma tendifilo	cam thread guide			
35	727203-0-00	2	vite	screw			
36	206543-0-00	1	guarnizione	gasket			
37	206544-0-00	1	guarnizione	gasket			
A	202539-4-00	1	<u>SOLO A RICHIESTA</u> coperchio volantino Quick Stop	<u>ONLY ON REQUEST</u> pulley cover for Quick Stop			
B	721525-0-00	1	vite	screw			
C	703007-0-00	1	rondella	washer			
D	202352-2-11	1	coperchio	cover			

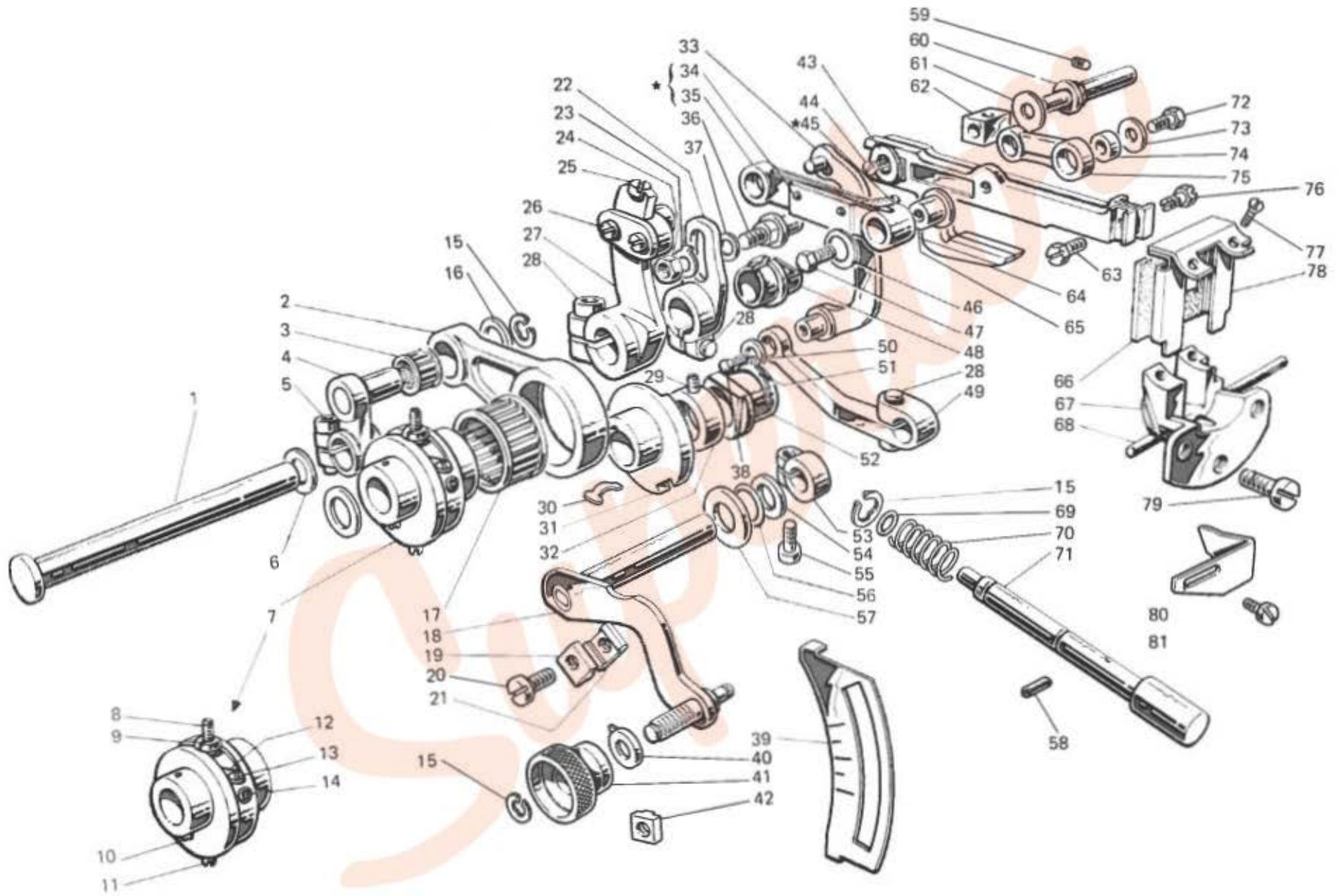

Fig. N. Abb. N.	Part. N. Bestell N. Piece N. Pieza N.	Qt. Anzahl	DESCRIZIONE	DESCRIPTION	BENENNUNG	DESCRIPTION	DESCRIPCION
★	206615-4-00	1	biellino compl.(figg.34-35-45)	connecting rod assembly			
1	206593-0-00	1	contralbero trasporto	transport countershaft			
2	206599-0-00	1	biella comando trasporto	transport connecting rod control			
3	201358-0-10	1	gabbia a rulli	needle cage			
4	206598-3-00	1	braccio a manovella con vite	connecting-rod with screw			
5	744334-2-00	1	vite	screw			
6	704841-0-00	1	rondella	washer			
7	206871-4-01	1	gruppo ecc.regol.trasporto	eccentric group			
8	729051-2-00	1	vite	screw			
9	206603-0-10	1	fermo eccentrico	eccentric retainer			
10	745125-2-00	1	vite	screw			
11	728272-0-00	1	vite	screw			
12	202412-0-10	1	lardone	gib			
13	202473-0-10	2	vite	screw			
14	202472-0-10	2	vite	screw			
15	700207-0-00	3	anello elastico	spring ring			
16	206546-0-00	1	rondella	washer			
17	202385-0-10	1	gabbia a rulli	needle cage			
18	206790-2-00	1	leva comando slitta	lever			
19	206799-0-00	1	arresto regolabile esterno	external retainer			
20	742222-2-00	2	vite	screw			
21	206795-0-00	2	arresto regolabile interno	internal retainer			
22	206584-2-00	1	braccio manovella	connecting rod			
23	206580-2-00	1	rondella con spira	washer with pin			
24	746008-0-00	1	dado	nut			
25	741413-0-00	1	vite	screw			
26	741546-2-00	2	vite	screw			
27	206592-3-00	1	manovella trasporto	transport crank			
28	744332-2-00	3	vite	screw			
29	745812-2-00	1	vite	screw			
30	206872-0-00	1	molla	spring			
31	206605-0-01	1	eccentrico	eccentric			
32	206606-2-00	1	anello di rasamento	shim			
33	202047-2-10	1	leva	lever			
34	200490-0-00	2	spillo	pin			
35	206587-0-00	1	biellino	connecting rod			
36	202063-0-10	1	spina	pin			
37	704808-0-00	1	rondella	washer			
38	740220-2-00	1	vite	screw			
39	206797-0-00	1	piastrina per indice	plate			
40	206796-0-00	1	indice rapp.differenziale	differential index			
41	206798-0-00	1	bottono rapp.differenziale	differential button			
42	206794-0-00	1	arresto regolabile esterno	external retainer			
43	202475-0-10	1	rondella	washer			
44	724032-0-00	1	vite	screw			
45	778417-0-00	1	stoppino	wick			
46	705008-0-00	1	rondella	washer			

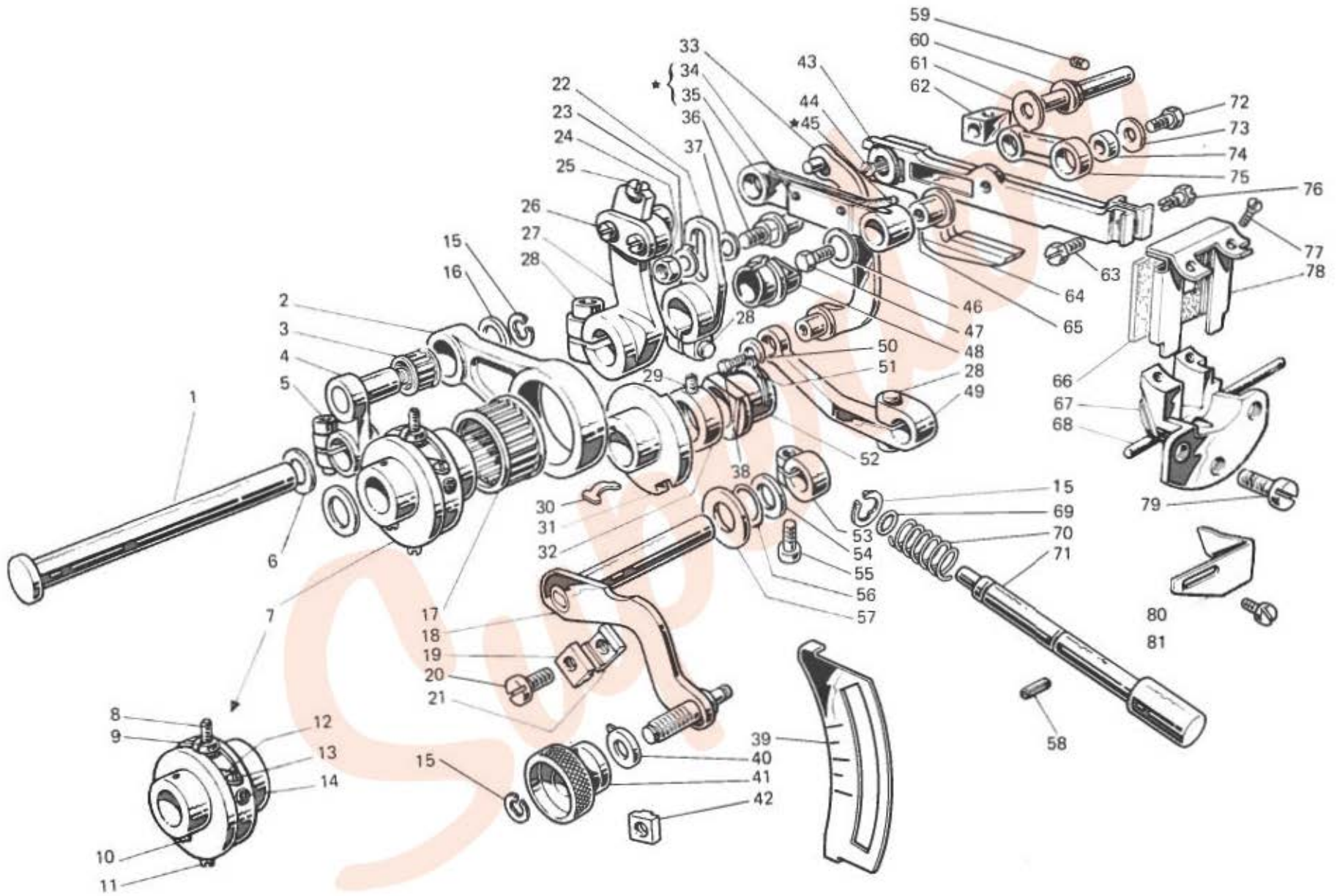

Fig. N. Abb. N.	Part. N. Bestell N. Piece N. Pieza N.	Qt. Anzahl	DESCRIZIONE	DESCRIPTION	BENENNUNG	DESCRIPTION	DESCRIPCION
47	206588-0-00	1	vite	screw			
48	206619-0-00	1	vaschetta olio	oil sump			
49	206614-2-00	1	braccio regol.differenziale	differential arm			
50	705201-0-00	1	rondella	washer			
51	201610-0-01	1	anello elastico	spring ring			
52	206617-0-00	1	blocchetto	block			
53	100620-0-10	1	morsetto	clamp			
54	704829-0-00	1	rondella	washer			
55	741745-2-00	1	vite	screw			
56	701007-0-00	1	anello di tenuta	retainer ring			
57	705230-0-00	1	rondella	washer			
58	729032-2-00	1	vite	screw			
59	202478-0-10	1	vite	screw			
60	206613-0-00	1	perno eccentrico	eccentric pin			
61	705408-0-00	1	rondella	washer			
62	202033-0-10	1	blocchetto	block			
63	202489-0-10	1	vite	screw			
64	206582-3-00	1	gruppo slitta porta griffe	feed dog slide group			
65	206586-0-00	1	bussola per biellino	bush			
66	206804-0-00	1	raschia olio	oil scraper			
67	206608-0-00	1	guida supporto a slitta	slide support guide			
68	206609-0-00	1	guarnizione guida	gasket			
69	701002-0-00	1	anello	ring			
70	202408-0-10	1	molla	spring			
71	206618-0-00	1	pulsante regola punto	bush-button			
72	202490-0-10	1	vite	screw			
73	705208-0-00	1	rondella	washer			
74	202032-0-10	1	bussolina	bush			
75	206583-0-00	1	biellino	connecting-rod			
76	202488-0-10	1	vite	screw			
77	744621-0-00	2	vite	screw			
78	206803-2-00	1	telaio raschiaolio	oil scraper frame			
79	721464-2-00	3	vite	screw			
80	204905-0-10	1	squadretta protez. griffe	feed dog bracket protection			
81	721443-2-00	1	vite	screw			

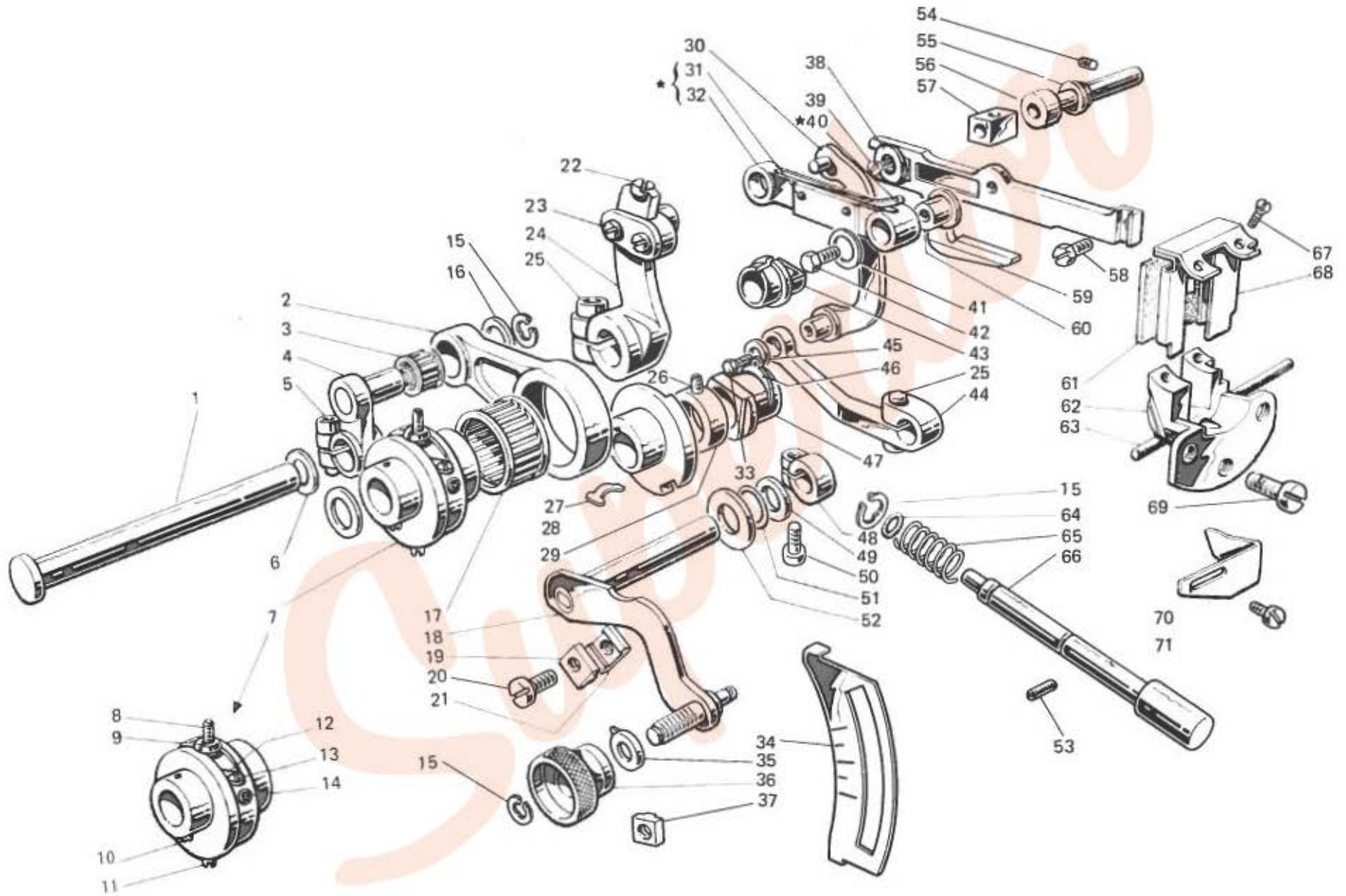

Fig. N. Abb. N.	Part. N. Bestell. N. Piece N. Pieza N.	Qt. Anzahl	DESCRIZIONE	DESCRIPTION	BENENNUNG	DESCRIPTION	DESCRIPCION
★	206615-4-00	1	biellino completo(figg.34-35-45)	con-rod assembly (figs.34-35-45)			
1	206593-0-00	1	contralbero trasporto	transport countershaft			
2	206599-0-00	1	biella comando trasporto	transport connecting rod control			
3	201358-0-10	1	gabbia a rulli	needle cage			
4	206598-3-00	1	braccio a manovella con vite	connecting-rod with screw			
5	744334-2-00	1	vite	screw			
6	704841-0-00	1	rondella	washer			
7	206998-4-00	1	gruppo eccentrico regolaz. trasporto	eccentric group			
8	729051-2-00	1	vite	screw			
9	206603-0-10	1	fermo eccentrico	eccentric retainer			
10	745125-2-00	1	vite	screw			
11	728272-0-00	1	vite	screw			
12	202412-0-10	1	lardone	gib			
13	202473-0-10	2	vite	screw			
14	202472-0-10	2	vite	screw			
15	700207-0-00	3	anello elastico	circlip			
16	206546-0-00	1	rondella	washer			
17	202385-0-10	1	gabbia a rulli	needle cage			
18	206790-2-00	1	leva comando slitta	lever			
19	206799-0-00	1	arresto regolabile esterno	external retainer			
20	742222-2-00	2	vite	screw			
21	206795-0-00	2	arresto regolabile interno	internal retainer			
22	741413-0-00	1	vite	screw			
23	741546-2-00	2	vite	screw			
24	206592-3-00	1	manovella trasporto	transport crank			
25	744332-2-00	2	vite	screw			
26	745812-2-00	1	vite	screw			
27	206872-0-00	1	molla	spring			
28	206605-0-01	1	eccentrico	eccentric			
29	206606-2-00	1	anello di rasamento	shim			
30	202047-2-10	1	leva	lever			
31	200490-0-00	2	spillo	pin			
32	206587-0-00	1	biellino	connecting rod			
33	740220-2-00	1	vite	screw			
34	206797-0-00	1	piastrina per indice	index plate			
35	206796-0-00	1	indice rapporto differenziale	differential index			
36	206798-0-00	1	bottone rapp.differenziale	differential button			
37	206794-0-00	1	arresto regolabile esterno	external retainer			
38	202475-0-10	1	rondella	washer			
39	724032-0-00	1	vite	screw			
40	778417-0-00	1	stoppino	wick			
41	705008-0-00	1	rondella	washer			
42	206588-0-00	1	vite	screw			
43	206619-0-00	1	vaschetta olio	oil sump			
44	206614-2-00	1	braccio regol.differenziale	differential adjustment arm			
45	705201-0-00	1	rondella	washer			
46	201610-0-01	1	anello elastico	circlip			

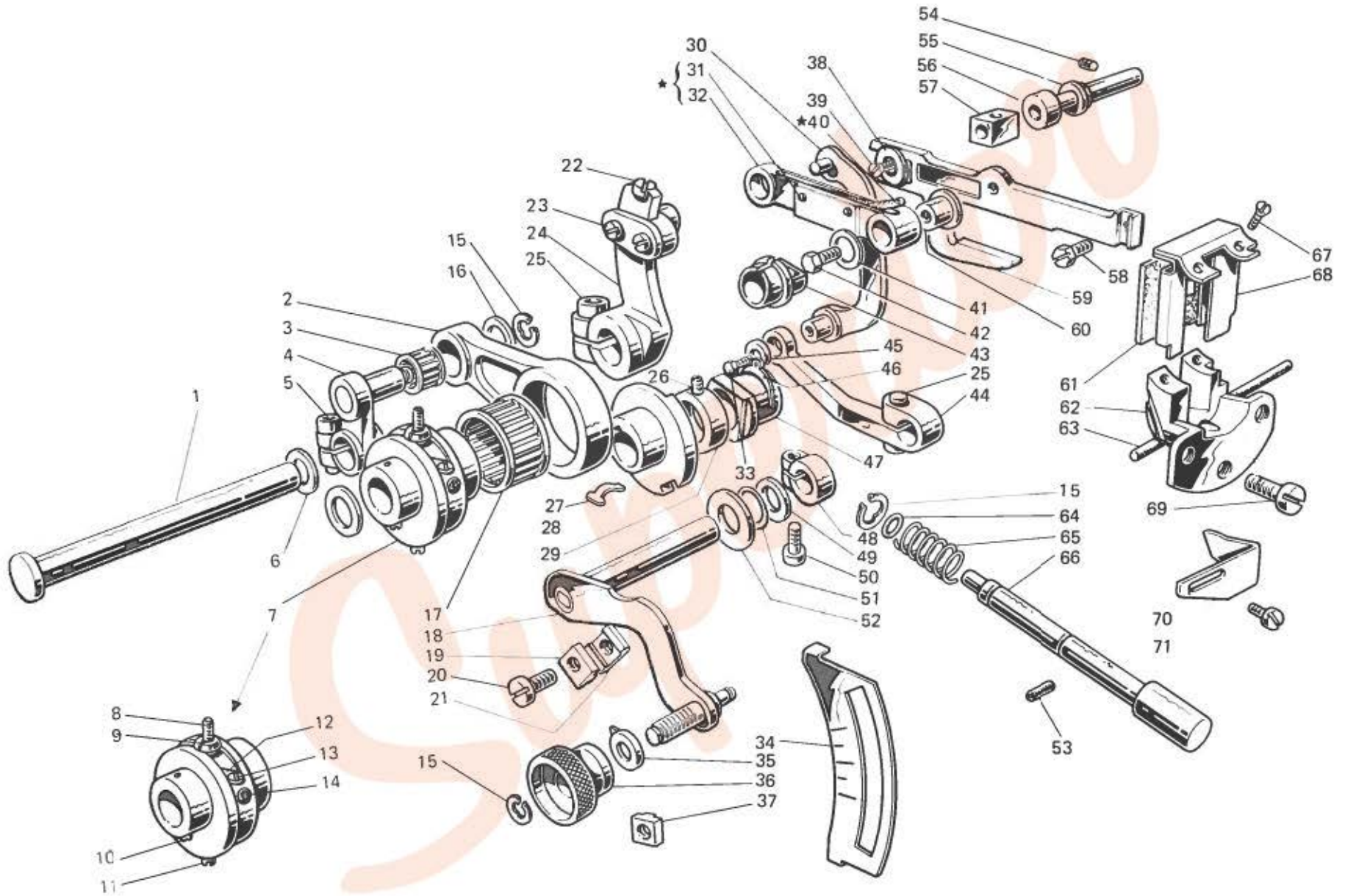

Fig. N. Abb. N.	Part. N. Bestell N. Piece N. Pieza N.	Qt. Anzahl	DESCRIZIONE	DESCRIPTION	BENENNUNG	DESCRIPTION	DESCRIPCION
47	206616-0-00	1	blocchetto	block			
48	100620-0-10	1	morsetto	clamp			
49	704829-0-00	1	rondella	washer			
50	741745-2-00	1	vite	screw			
51	701007-0-00	1	anello di tenuta	oil retainer ring			
52	705230-0-00	1	rondella	washer			
53	729032-2-00	1	vite	screw			
54	202478-0-10	1	vite	screw			
55	206613-0-00	1	perno eccentrico	eccentric pin			
56	202973-0-10	1	rondella	washer			
57	202922-0-10	1	blocchetto	block			
58	202489-0-10	1	vite	screw			
59	206585-0-00	1	supporto sinistro porta griffa	left feed-dog support			
60	206586-0-00	1	bussola per biellino	bush			
61	206805-0-00	1	raschiaolio	oil scraper			
62	206847-0-00	1	guida supporto a slitta	guide for slide support			
63	206609-0-00	1	guarnizione guida	gasket			
64	701002-0-00	1	anello	ring			
65	202408-0-10	1	molla	spring			
66	206618-0-00	1	pulsante regola punto	bush-button			
67	744621-0-00	2	vite	screw			
68	206807-2-00	1	telaio raschiaolio	oil scraper frame			
69	721464-2-00	3	vite	screw			
70	204905-0-10	1	squadretta protez.griffe	feed-dog protection bracket			
71	721443-2-00	1	vite	screw			

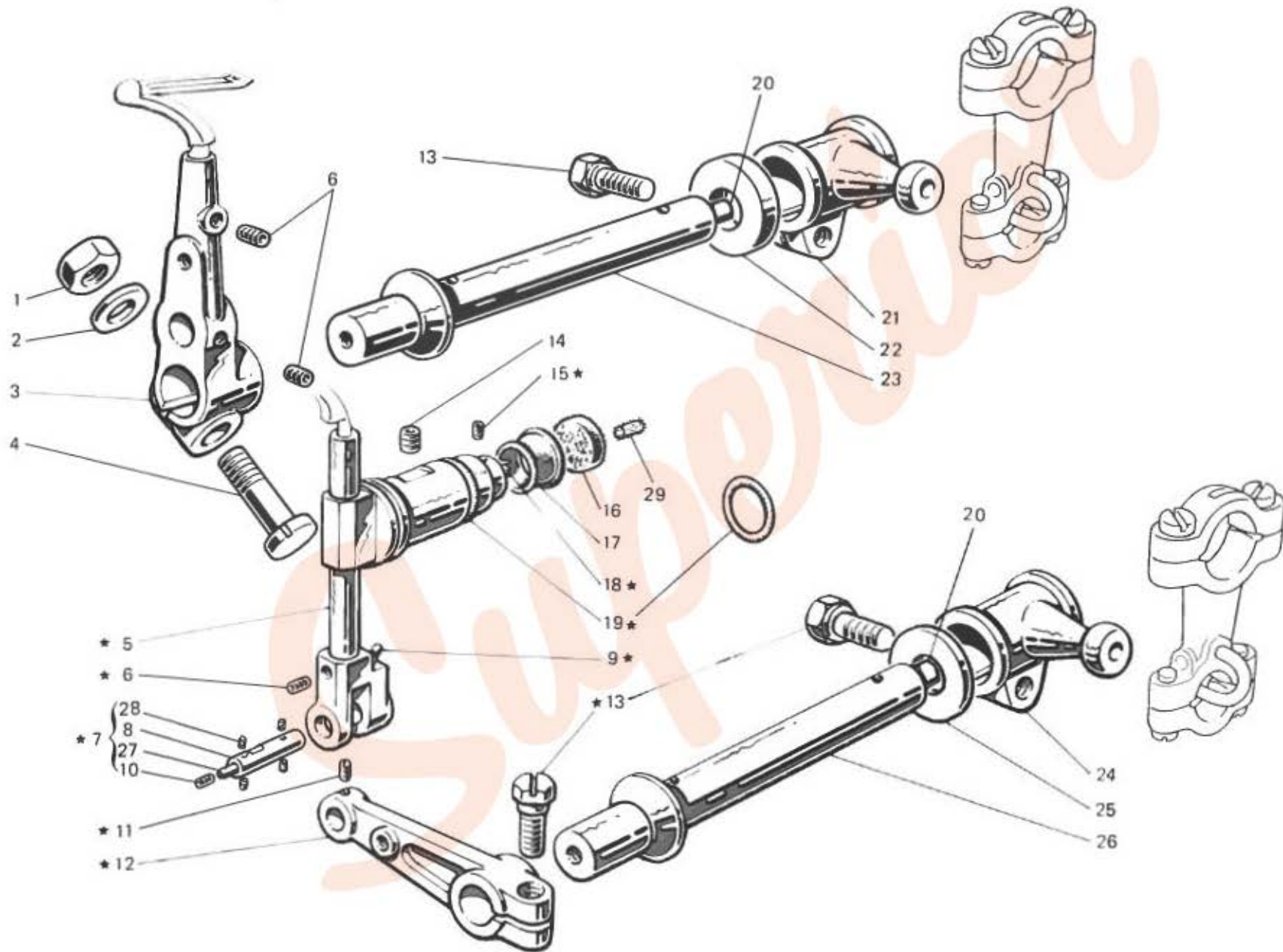

Fig. N. Abb N.	Part. N. Bestell N. Pieze N. Pieza N.	Qt. Anzahl	DESCRIZIONE	DESCRIPTION	BENENNUNG	DESCRIPTION	DESCRIPCION
★	206415-4-00	1	gruppo com. crochet sup.	upper looper control			
1	746408-2-00	1	dado	nut			
2	705013-0-00	1	rondella	washer			
3	204671-0-10	1	porta crochet inferiore	lower looper holder			
4	204700-0-10	1	perno a vite	pin			
5	206410-3-00	1	guida oscillante	oscillating guide			
6	745812-2-00	3	vite fissa crochet	screw			
7	206645-4-00	1	spina	pin			
8	202086-0-10	1	spina	pin			
9	778208-0-00	1	stoppino	wick			
10	745002-2-00	1	vite	screw			
11	745800-2-00	1	vite	screw			
12	206652-2-00	1	braccio	arm			
13	201128-0-10	3	vite	screw			
14	745168-0-00	1	vite	screw			
15	727002-0-00	2	vite	screw			
16	206686-0-00	1	disco lubrif.guida	lubrication disc			
17	202720-0-00	1	paraolio	oil retainer			
18	778417-0-00	1	stoppino	wick			
19	701113-0-00	1	anello di tenuta	retainer ring			
20	206695-0-00	2	tappo per albero	plug for shaft			
21	206659-2-00	1	manicotto con vite	coupling with screw			
22	704847-0-00	1	rondella	washer			
23	206656-0-00	1	albero crochet inferiore	lower looper shaft			
24	206658-2-00	1	manicotto	coupling			
25	704845-0-00	1	rondella	washer			
26	206646-0-00	1	albero crochet super.	upper looper shaft			
27	778401-0-00	1	stoppino	wick			
28	778202-0-00	4	stoppino	wick			
29	778236-0-00	1	stoppino	wick			

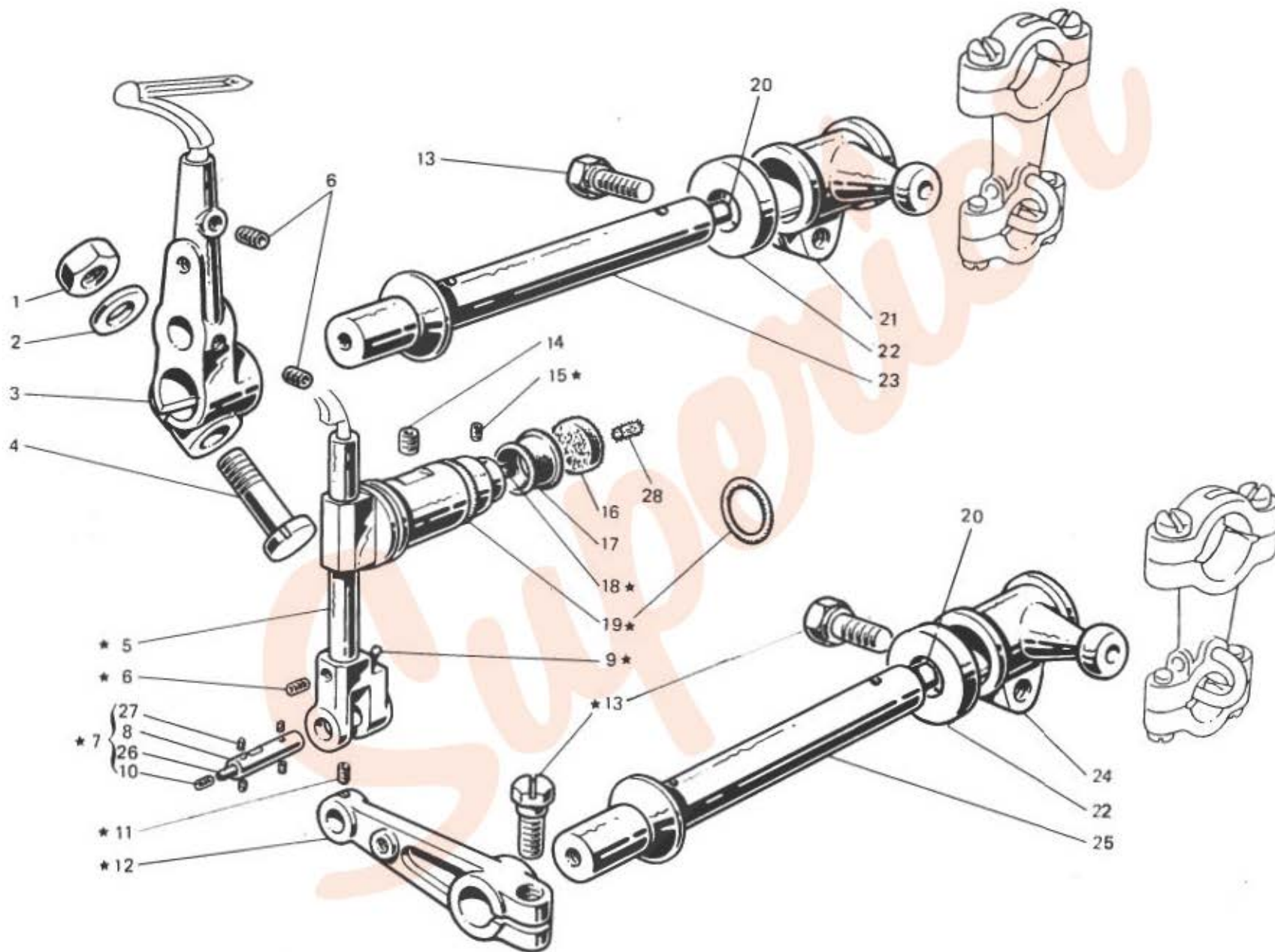

Fig. N. Abb. N.	Part. N. Bestell N. Piece N. Pieza N.	Qt. Anzahl	DESCRIZIONE	DESCRIPTION	BENENNUNG	DESCRIPTION	DESCRIPCION
★	206419-4-00	1	gruppo comando crochet superiore	upper looper control			
1	746408-2-00	1	dado	nut			
2	705013-0-00	1	rondella	washer			
3	204671-0-10	1	porta crochet inferiore	lower looper holder			
4	204700-0-10	1	perno a vite	pin			
5	206413-3-00	1	guida oscillante	oscillating guide			
6	745812-2-00	3	vite fissa crochet	looper screw			
7	206645-4-00	1	spina	pin			
8	202086-0-10	1	spina	pin			
9	778208-0-00	1	stoppino	wick			
10	745002-2-00	1	vite	screw			
11	745800-2-00	1	vite	screw			
12	206653-2-00	1	braccio	arm			
13	201128-0-10	3	vite	screw			
14	745168-0-00	1	vite	screw			
15	727002-0-00	2	vite	screw			
16	206686-0-00	1	disco lubrificazione guida	lubrication disc			
17	202720-0-00	1	paraolio	oil retainer			
18	778417-0-00	1	stoppino	wick			
19	701113-0-00	1	anello di tenuta	retainer ring			
20	206695-0-00	2	tappo per albero	plug for shaft			
21	206659-2-00	1	manicotto con vite	coupling with screw			
22	704847-0-00	2	rondella	washer			
23	206656-0-00	1	albero crochet inferiore	lower looper shaft			
24	206648-2-00	1	manicotto con viti	coupling with screws			
25	206647-0-00	1	albero crochet superiore	upper looper shaft			
26	778401-0-00	1	stoppino	wick			
27	778202-0-00	4	stoppino	wick			
28	778236-0-00	1	stoppino	wick			

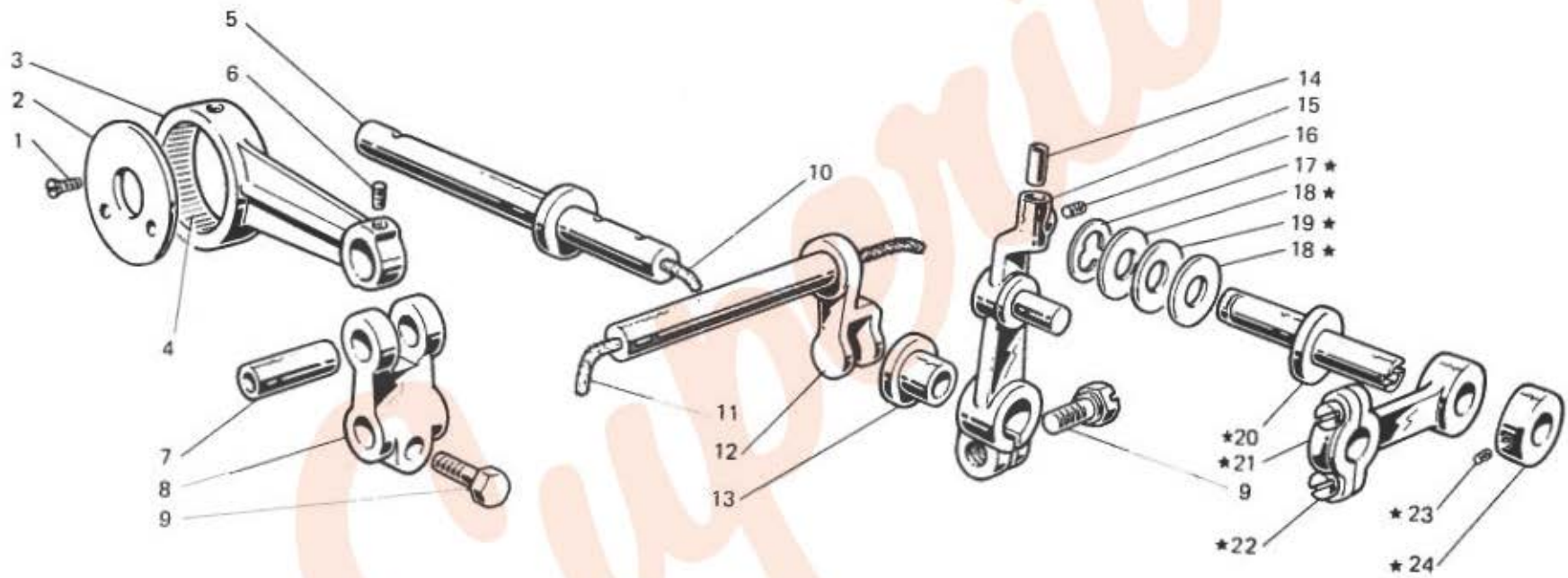

Fig. N. Abb. N.	Part. N. Bestell N. Piece N. Pieza N.	Qt. Anzahl	DESCRIZIONE	DESCRIPTION	BENENNUNG	DESCRIPTION	DESCRIPCION
★	204855-4-10	1	gruppo bielle rotazione crochet con fig. 1-2-3-4-6-Tav.7	looper rotation con-rod assembly with fig. 1-2-3-4-6- Tav. 7			
1	744530-0-00	2	vite	screw			
2	204789-0-10	1	rondella	washer			
3	204762-0-11	1	biella comando crochet	looper control con-rod			
4	204787-0-10	1	gabbia a rullini	needle cage			
5	204778-3-10	1	alberino con corona	shaft			
6	745124-0-00	1	vite	screw			
7	204659-0-10	1	spina per attacco forcella	pin for coupling			
8	204755-2-10	1	attacco a forcella	coupling			
9	202487-0-10	2	vite	screw			
10	778421-0-00	1	stoppino	wick			
11	778408-0-00	1	stoppino	wick			
12	204776-0-10	1	perno con forcella	pin with fork			
13	204769-0-10	1	bussola	bush			
14	205125-0-00	1	bussolina distanziale	spacer bush			
15	204647-3-10	1	porta crochet	looper holder			
16	745812-2-00	1	vite per fissaggio crochet	looper screw			
17	700208-0-00	1	anello elastico	circlip			
18	704813-0-00	2	rondella	washer			
19	702412-0-00	1	molla a tazza	cup spring			
20	204913-0-10	1	spina eccentrica	eccentric pin			
21	204764-3-10	1	biella	con-rod			
22	204800-0-10	2	vite	screw			
23	745800-2-00	2	vite	screw			
24	204773-0-10	1	anello di registro	adjustment ring			
14	204912-0-10	1	VARIANTE PER 329-00-2CD-12 bussolina distanziale	VARIATION FOR 329-00-2CD-12 spacer bush			

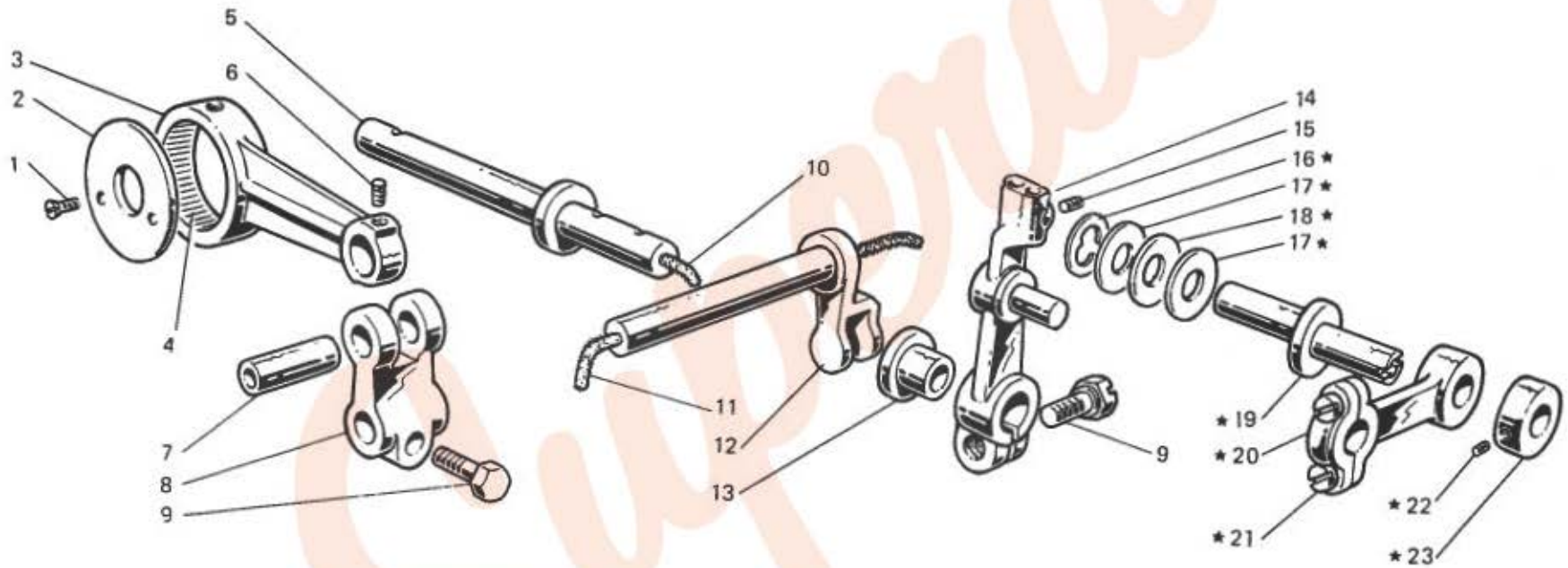

Fig. N. Abb. N.	Part. N. Bestell N. Piece N. Pieza N.	Qt. Anzahl	DESCRIZIONE	DESCRIPTION	BENENNUNG	DESCRIPTION	DESCRIPCION
★	206989-4-00	1	gruppo bielle rotazione crochet con fig. 1-2-3-4-6 Tav. 7A	looper rotation con-rod assembly with figs. 1-2-3-4-6 Tav. 7A			
1	744530-0-00	2	vite	screw			
2	204789-0-10	1	rondella	washer			
3	204762-0-11	1	biella comando crochet	looper control con-rod			
4	204787-0-10	1	gabbia a rullini	needle cage			
5	204778-3-10	1	alberino con corona	shaft			
6	745124-0-00	1	vite	screw			
7	204659-0-10	1	spina per attacco a forcella	pin for coupling			
8	204755-2-10	1	attacco a forcella	coupling			
9	202487-0-10	2	vite	screw			
10	778421-0-00	1	stoppino	wick			
11	778408-0-00	1	stoppino	wick			
12	204776-0-10	1	perno con forcella	pin with fork			
13	204769-0-10	1	bussola	bush			
14	206047-3-01	1	porta crochet	looper holder			
15	745812-2-00	2	vite fissaggio crochet	looper screw			
16	700208-0-00	1	anello elastico	circlip			
17	704813-0-00	2	rondella	washer			
18	702412-0-00	1	molla a tazza	cup spring			
19	206990-0-00	1	spina eccentrica	eccentric pin			
20	204764-3-10	1	biella	con-rod			
21	204800-0-10	2	vite	screw			
22	745800-2-00	2	vite	screw			
23	204773-0-10	1	anello di registro	adjustment ring			

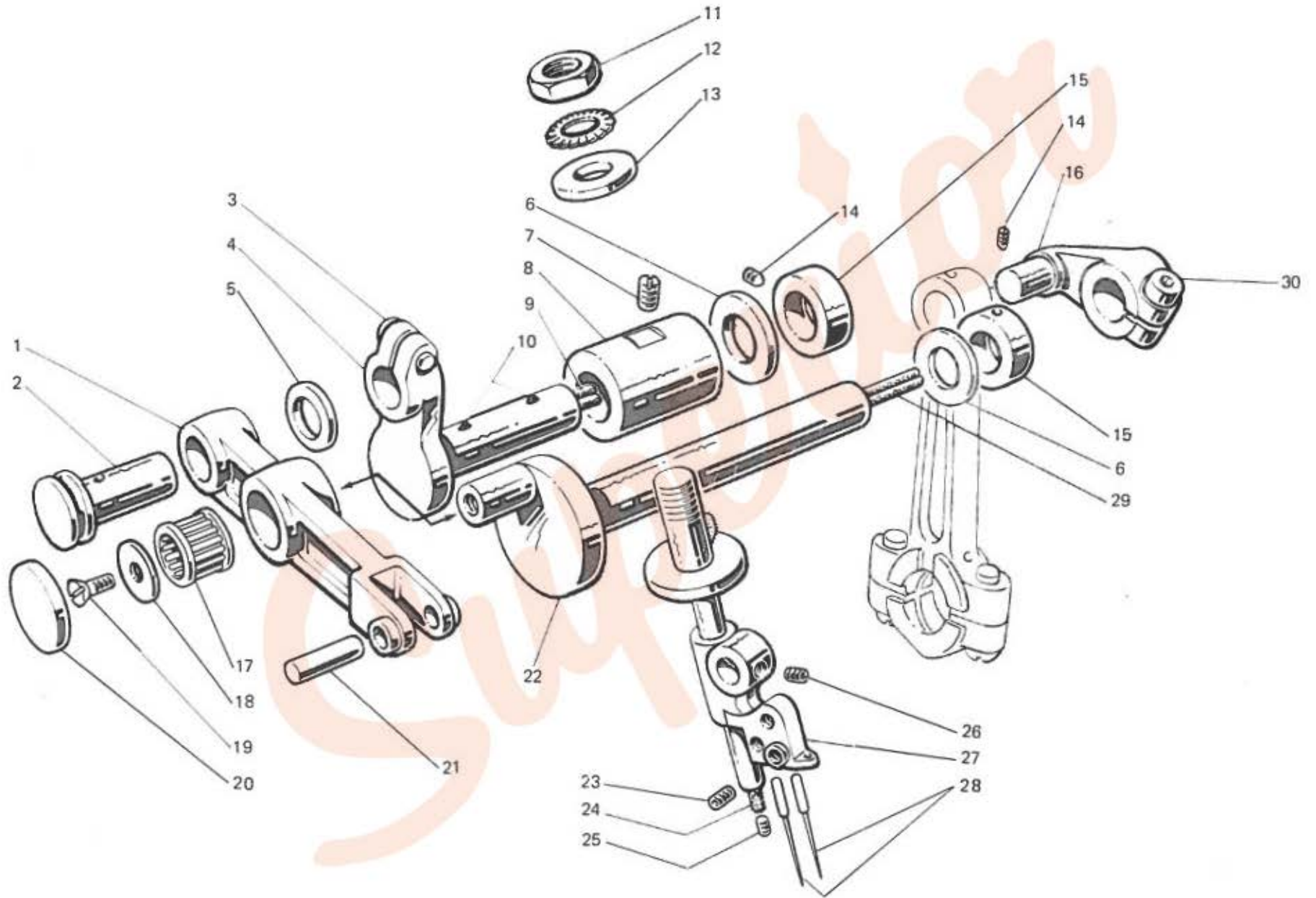

Fig. N. Abb. N.	Part. N. Bestell N. Pieze N. Pieza N.	Qt. Anzahl	DESCRIZIONE	DESCRIPTION	BENENNUNG	DESCRIPTION	DESCRIPCION
★	206431-4-00	1	cinematismo comando ago	needle control assembly			
1	206515-0-00	1	leva	lever			
2	206525-3-00	1	perno	pin			
3	744332-2-00	1	vite	screw			
4	206522-3-00	1	albero con vite	shaft with screw			
5	704837-0-00	1	rondella	washer			
6	705029-0-00	2	rondella	washer			
7	727706-0-00	1	vite	screw			
8	206524-0-00	1	bussola	bush			
9	778407-0-00	1	stoppino	wick			
10	778203-0-00	4	stoppino	wick			
11	206506-0-00	1	dado	nut			
12	703210-0-00	1	rondella	washer			
13	206514-0-00	1	rondella	washer			
14	745812-2-00	2	vite	screw			
15	206606-2-00	2	anello	ring			
16	206540-2-00	1	manovella albero superiore con vite	upper shaft crank with screw			
17	206518-0-00	1	gabbia a rullini	needle cage			
18	206531-0-00	1	rondella	washer			
19	724032-0-00	1	vite	screw			
20	206533-0-00	1	coperchio per leva	cover for lever			
21	206529-4-00	1	spina	pin			
22	206530-4-00	1	albero a manovella con stoppino	crank shaft with wick			
23	745800-2-00	2	vite	screw			
24	778400-0-00	1	stoppino	wick			
25	745001-0-00	1	vite	screw			
26	745002-0-00	1	vite	screw			
27	206833-4-00	1	barra con morsetto fig.24-25	needle bar with clamp fig.24-25			
28	765200-6-11	2	ago sit,Rim27 fin.110	needle Rim 27 fin.110			
29	778837-0-00	1	stoppino	wick			
30	744334-2-00	1	vite	screw			
★	206429-4-00	1	VARIANTE PER 329-00-2CD-12 cinematismo comando ago	VARIATION FOR 329-00-2CD-12 needle control assembly			
1	206516-0-00	1	leva	lever			
27	206827-4-00	1	barra con morsetto fig.24-25	needle bar with clamp fig.24-25			
28	765200-6-90	2	ago sist,Rim27 fin.90	needle Rim27 fin.90			

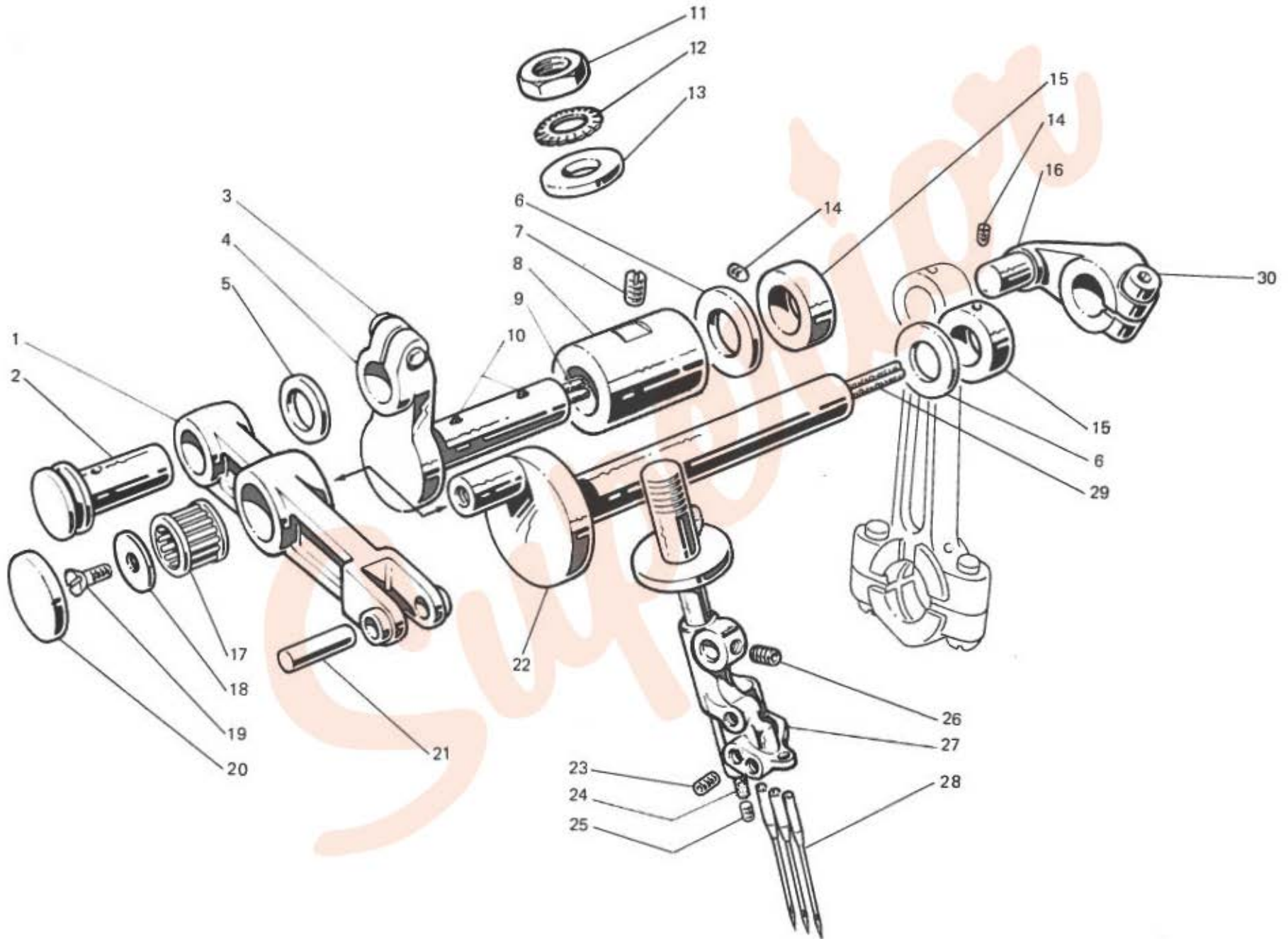

Fig. N. Abb. N.	Part. N. Bestell N. Piece N. Pieza N.	Qt. Arzahi	DESCRIZIONE	DESCRIPTION	BENENNUNG	DESCRIPTION	DESCRIPCION
★	206433-4-00	1	cinematismo comando ago	needle control assembly			
1	206515-0-00	1	leva	lever			
2	206525-3-00	1	perno	pin			
3	744332-2-00	1	vite	screw			
4	206522-3-00	1	albero	shaft			
5	704837-0-00	1	rondella	washer			
6	705029-0-00	2	rondella	washer			
7	727706-0-00	1	vite	screw			
8	206524-0-00	1	bussola	bush			
9	778407-0-00	1	stoppino	wick			
10	778203-0-00	4	stoppino	wick			
11	206506-0-00	1	dado	nut			
12	703210-0-00	1	rondella	washer			
13	206514-0-00	1	rondella	washer			
14	745812-2-00	2	vite	screw			
15	206606-2-00	2	anello	ring			
16	206542-2-00	1	manovella albero super.con viti	crank for upper shaft with screws			
17	206518-0-00	1	gabbia a rullini	needle cage			
18	206531-0-00	1	rondella	washer			
19	724032-0-00	1	vite	screw			
20	206533-0-00	1	coperchio per leva	cover for lever			
21	206529-4-00	1	spina	pin			
22	206530-4-00	1	albero a manovella con stoppini	shaft with wicks			
23	745800-2-00	2	vite	screw			
24	778400-0-00	1	stoppino	wick			
25	745001-0-00	1	vite	screw			
26	745002-0-00	1	vite	screw			
27	206839-4-00	1	barra con morsetto fig.24-25	needle bar with clamp fig.24-25			
28	765200-6-12	3	ago sist. Rim27 fin.120	needle Rim27 fin.120			
29	778837-0-00	1	stoppino	wick			
30	744334-2-00	1	vite	screw			

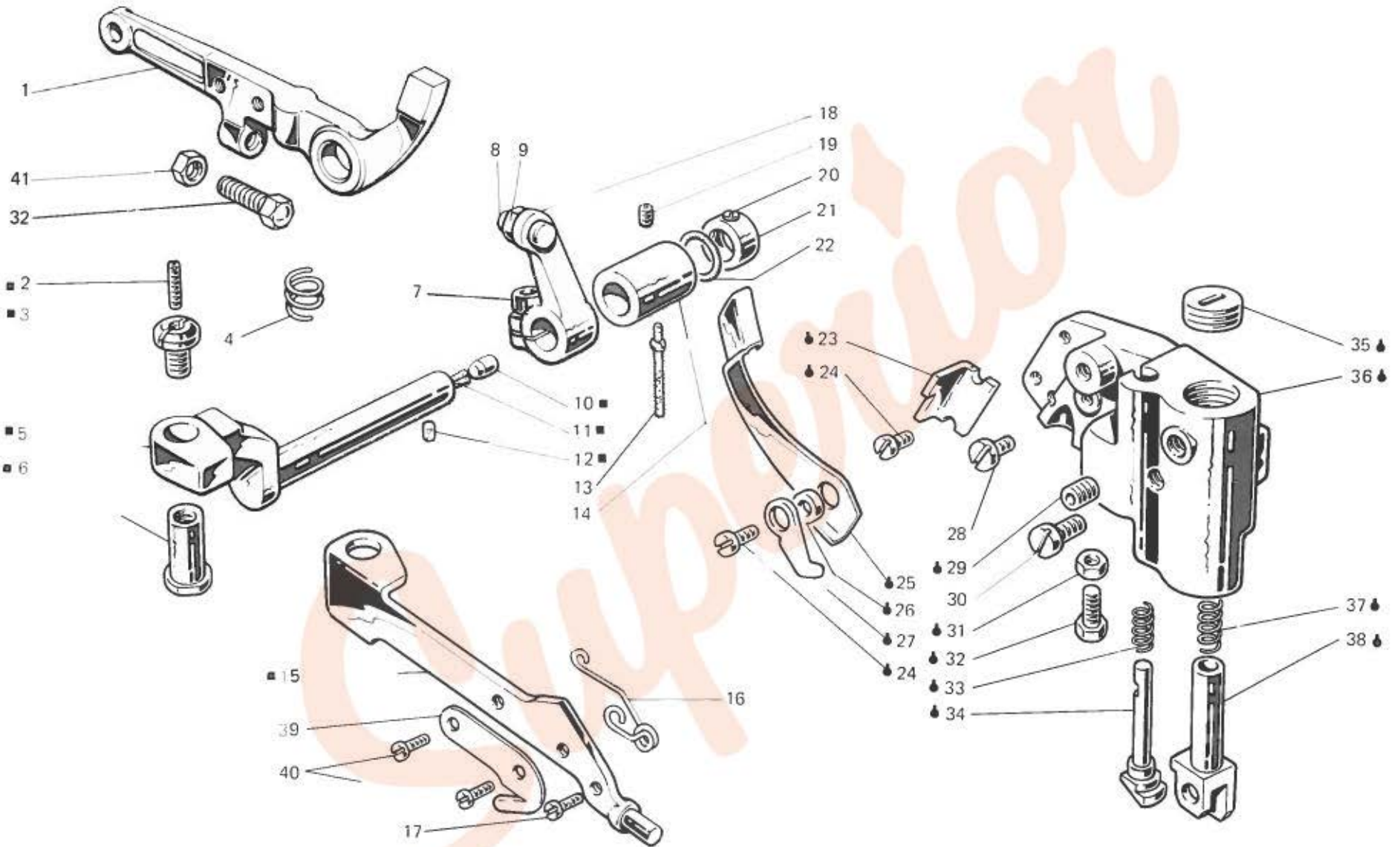

Fig. N° Abt. N°	Part. N° Bestell. N° Pieze N°	Q.t. Anzahl	DESCRIZIONE	DESCRIPTION	BENENNUNG	DESCRIPTION	DESCRIPCION
●	206447-4-01	1	gruppo supp.premistoffa	presser support assembly			
■	206809-4-00	1	leva premistoffa con perno (con fig.2-3-5-6-15)	presser lever with pin (with fig. 2-3-5-6-15)			
1	206630-0-00	1	leva alza premistoffa	lever			
2	729051-2-00	1	vite	screw			
3	202529-0-10	1	perno di fermo	pin			
4	206621-0-00	1	molla	spring			
5	206626-3-00	1	perno (con fig.10-11-12)	shaft (with fig.10-11-12)			
6	206622-0-00	1	spina	pin			
7	744332-2-00	1	vite	screw			
8	727096-0-00	1	vite	screw			
9	746020-2-00	1	dado	nut			
10	301586-0-10	1	pastiglia	plug			
11	778520-0-00	1	stoppino	wick			
12	778203-0-00	1	stoppino	wick			
13	206620-0-00	1	stoppino	wick			
14	206629-0-00	1	bussola	bush			
15	206625-0-00	1	leva	lever			
16	205042-0-11	1	molla premipedino	spring			
17	203187-0-10	1	vite fissa molla	screw			
18	206623-2-11	1	leva arresto premist.con viti	lever with screws			
19	745812-2-00	1	vite	screw			
20	745114-0-00	2	vite	screw			
21	206644-2-00	1	anello con viti	ring with screws			
22	701006-0-00	2	anello di tenuta	retainer ring			
23	206639-0-00	1	arresto	stopping			
24	721464-2-00	3	vite	screw			
25	206636-0-00	1	leva	lever			
26	206637-0-00	1	distanziale	spacer			
27	206635-0-00	1	nasello	snug			
28	721494-2-00	1	vite	screw			
29	202391-0-10	1	vite	screw			
30	206642-0-00	1	vite	screw			
31	746007-2-00	1	dado	nut			
32	202214-0-10	2	vite	screw			
33	202110-0-10	1	molla	spring			
34	206634-0-00	1	tirante	tie-rod			
35	206633-0-00	1	vite	screw			
36	206640-0-01	1	supporto	support			
37	205021-0-10	1	molla	spring			
38	206632-2-00	1	cannotto	column			
39	202194-0-10	1	piastrina taglia catenella	chain cutting sheet			
40	741433-0-00	2	vite	screw			
41	733505-2-00	1	dado	nut			
			VARIANTE PER 329-00-2CD-12 - 329-00-3MU-01	VARIATION FOR 329-00-2CD-12 - 329-00-3MU-01			
16	204891-0-11	1	molla premipedino	spring			

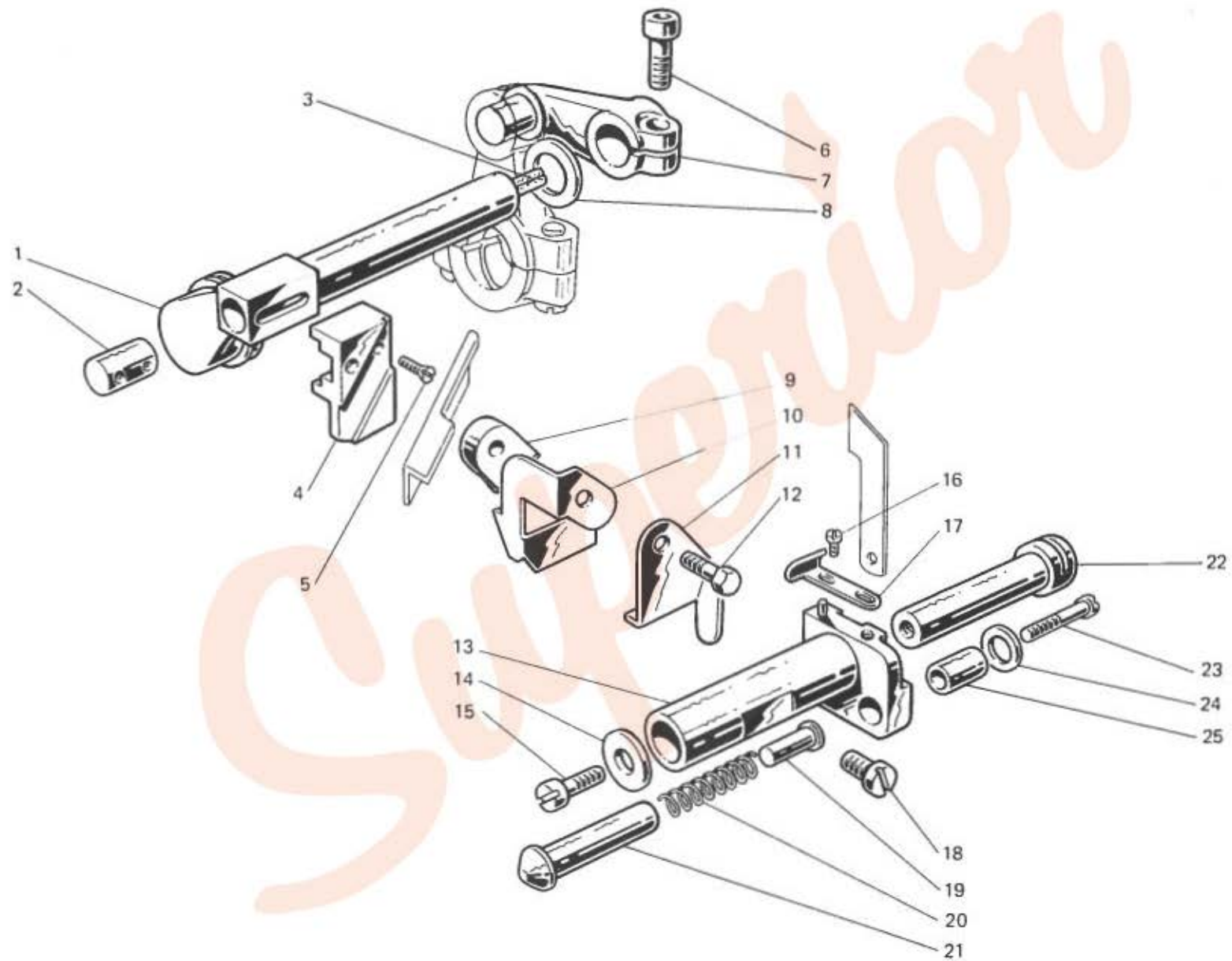

Fig. N. Abb. N.	Part. N. Bestell N. Pieze N. N.	Qt. Anzahl	DESCRIZIONE	DESCRIPTION	BENENNUNG	DESCRIPTION	DESCRIPCION
1	206572-4-00	1	albero colt.sup.con stoppino	upper knife shaft with wick			
2	202130-0-10	1	perno	pin			
3	778832-0-00	1	stoppino	wick			
4	204681-0-10	1	placchetta	plate			
5	744573-0-00	1	vite	screw			
6	744334-2-00	1	vite	screw			
7	206574-2-00	1	manov.alb.colt.sup.con vite	crank for upper knife shaft			
8	705029-0-00	1	rondella	shaft			
9	202131-0-10	1	nasello	snug			
10	204699-0-11	1	carterino	cover			
11	204691-0-10	1	carterino	cover			
12	204799-0-10	1	vite fissa coltello sup.	screw			
13	204685-2-10	1	porta coltello inferiore	lower knife holding			
14	704409-0-00	1	rondella	washer			
15	742457-2-00	1	vite fissa coltello inferiore	screw			
16	741520-0-10	1	vite	screw			
17	205024-0-10	1	spingi asola	front needle guard			
18	742758-0-00	1	vite	screw			
19	206758-0-10	1	puntalino	pin			
20	202128-0-10	1	molla	spring			
21	206757-0-00	1	bussolina	bush			
22	204687-0-10	1	perno	pin			
23	722471-2-00	1	vite	screw			
24	704802-0-00	1	rondella	washer			
25	202129-0-10	1	bussola	bush			
			VARIANTE PER 329-00-2CD-12	VARIATION FOR 329-00-2CD-12			
17	204690-0-10	1	spingi asola	front needle guard			

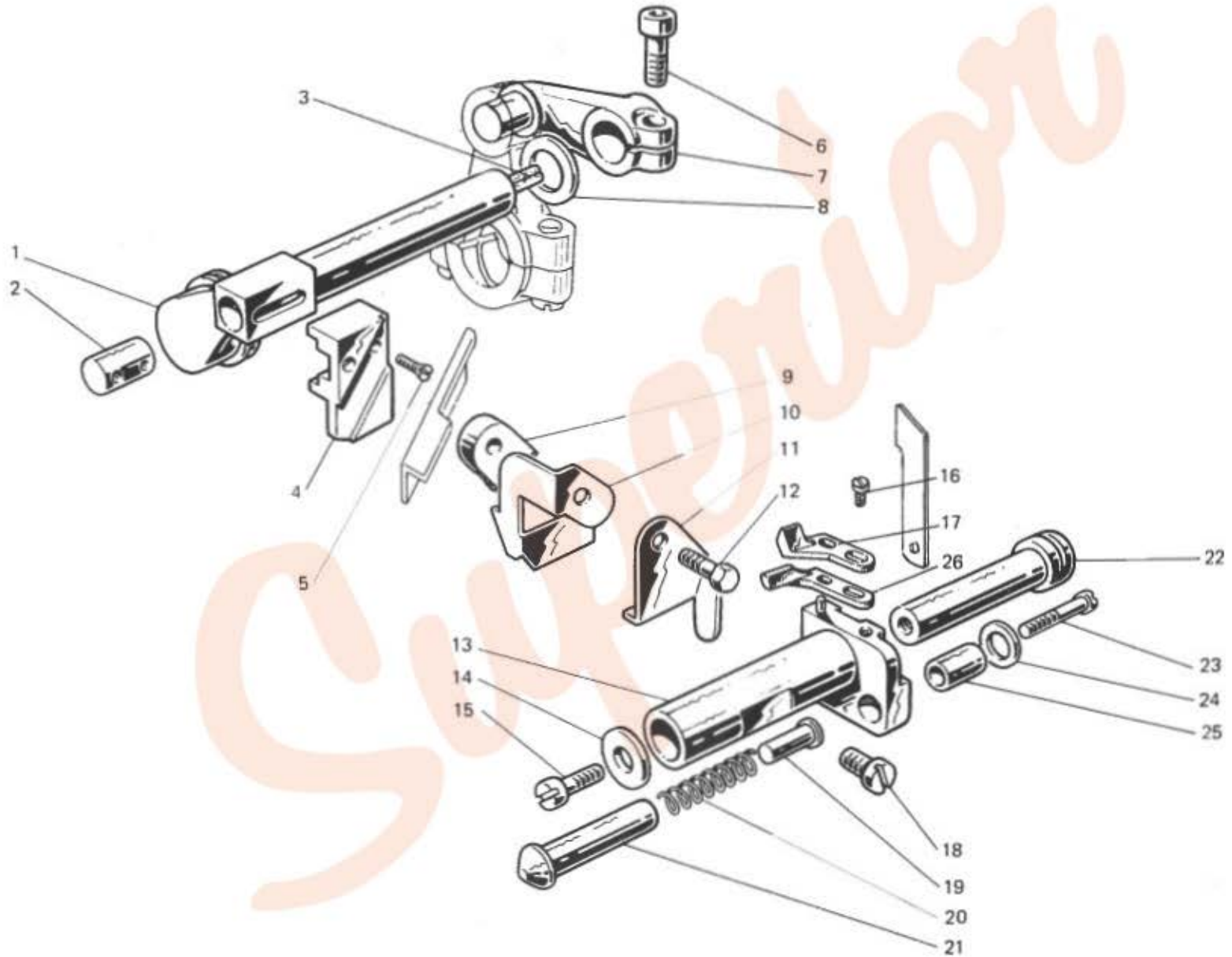

Fig. N. Abb. N.	Part. N. Bestell N. Piece N. Pieza N.	Qt. Anzahl	DESCRIZIONE	DESCRIPTION	BENENNUNG	DESCRIPTION	DESCRIPCION
1	206572-4-00	1	albero coltello super.con stoppino	upper knife shaft with wick			
2	202130-0-1Q	1	perno	pin			
3	778832-0-00	1	stoppino	wick			
4	204681-0-10	1	placchetta	plate			
5	744573-0-00	1	vite	screw			
6	744334-2-00	1	vite	screw			
7	206574-2-00	1	manovella alb.coltello super.con vite	crank for upper knife shaft with screw			
8	705029-0-00	1	rondella	washer			
9	202131-0-10	1	nasello	snug			
10	204699-0-11	1	carterino	cover			
11	204691-0-10	1	carterino	cover			
12	204799-0-10	1	vite fissa coltello superiore	upper knife screw			
13	206061-2-00	1	porta coltello inferiore	lower knife holder			
14	704409-0-00	1	rondella	washer			
15	742457-2-00	1	vite fissa coltello inferiore	lower knife screw			
16	741535-0-00	1	vite	screw			
17	206052-0-10	1	spingi asola	front needle guard			
18	742758-0-00	1	vite	screw			
19	206758-0-10	1	puntalino	pin			
20	202128-0-10	1	molla	spring			
21	206757-0-00	1	bussolina	bush			
22	204687-0-10	1	perno	pin			
23	722471-2-00	1	vite	screw			
24	704802-0-00	1	rondella	washer			
25	202129-0-10	1	bussola	bush			
26	206053-0-10	1	spingi asola	front needle guard			

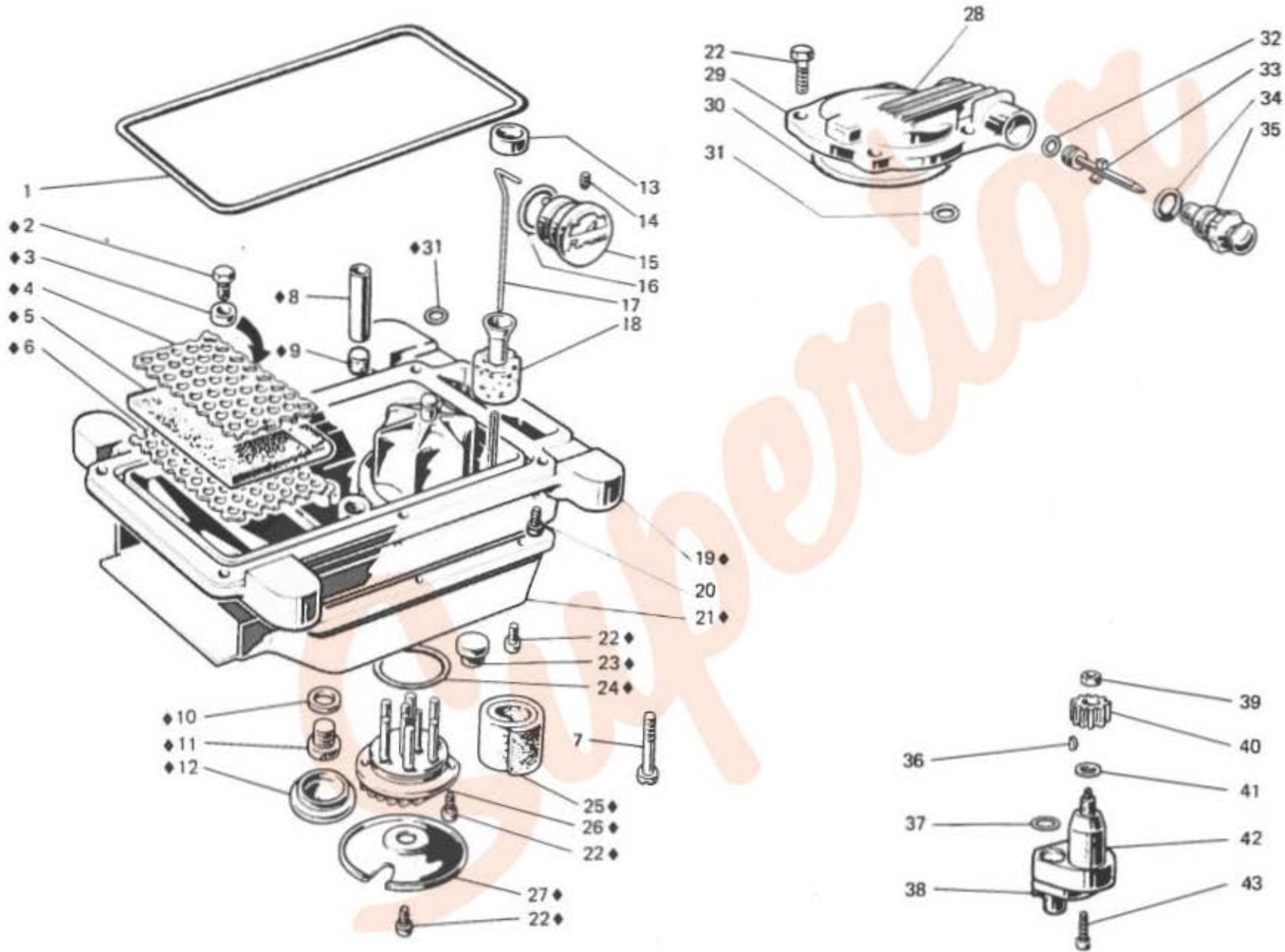

Fig. N. Abb. N.	Part. N. Bestell N. Piecce N. Pieza N.	Qt. Anzahl	DESCRIZIONE	DESCRIPTION	BENENNUNG	DESCRIPTION	DESCRIPCION
◆	206510-4-00	1	bacinella olio compl.	oil sump assembly			
1	206570-0-00	1	guarnizione bacinella	gasket			
2	721484-2-00	1	vite	screw			
3	990335-0-10	1	distanziale	spacer			
4	206567-0-00	1	lamiera forata sup.	upper sheet			
5	206566-0-00	1	filtro	filter			
6	206565-0-00	1	lamiera forata inf.	lower sheet			
7	206642-0-00	1	vite	screw			
8	206568-0-01	1	tu betto	tube			
9	206569-0-00	1	filtro	filter			
10	705977-0-00	1	rondella	washer			
11	206564-0-00	1	tappo	plug			
12	206752-0-00	1	tappo	plug			
13	206667-0-00	1	tappo decompressione	plug			
14	745812-2-00	1	vite	screw			
15	206669-2-00	1	indicatore livello olio	oil level gauge			
16	701032-0-00	1	anello di tenuta	oil ring			
17	206666-0-00	1	astina ind.liv.olio	stick			
18	206665-2-00	1	galleggiante compl.	float			
19	206509-3-00	1	bacinella	oil sump			
20	722442-2-00	6	vite	screw			
21	206750-0-00	1	convogliatore	conveyor			
22	721464-2-00	13	vite	screw			
23	206751-0-00	4	tampone	pad			
24	701050-0-00	1	guarnizione	gasket			
25	206559-0-00	1	filtro	filter			
26	206560-0-00	1	coperchio	cover			
27	206753-0-00	1	coperchio	cover			
28	206742-4-00	1	coperchio distrib.olio	oil distributor cover			
29	206736-2-00	1	coperchio	cover			
30	701151-0-00	1	anello di tenuta	oil ring			
31	701005-0-00	2	anello di tenuta	oil ring			
32	701104-0-00	1	anello di tenuta	oil ring			
33	206743-3-00	1	ugello	nozzle			
34	701113-0-00	1	anello di tenuta	oil ring			
35	206739-0-00	1	spia olio	oil window			
36	206557-0-00	1	chiavetta	key			
37	701004-0-00	1	anello di tenuta	oil ring			
38	721474-2-00	2	vite	screw			
39	733507-0-00	1	dado	nut			
40	206555-0-00	1	ruota	wheel			
41	704813-0-00	1	rondella	washer			
42	206550-4-00	1	gruppo pompa olio	oil pump assembly			
43	722481-2-00	2	vite	screw			

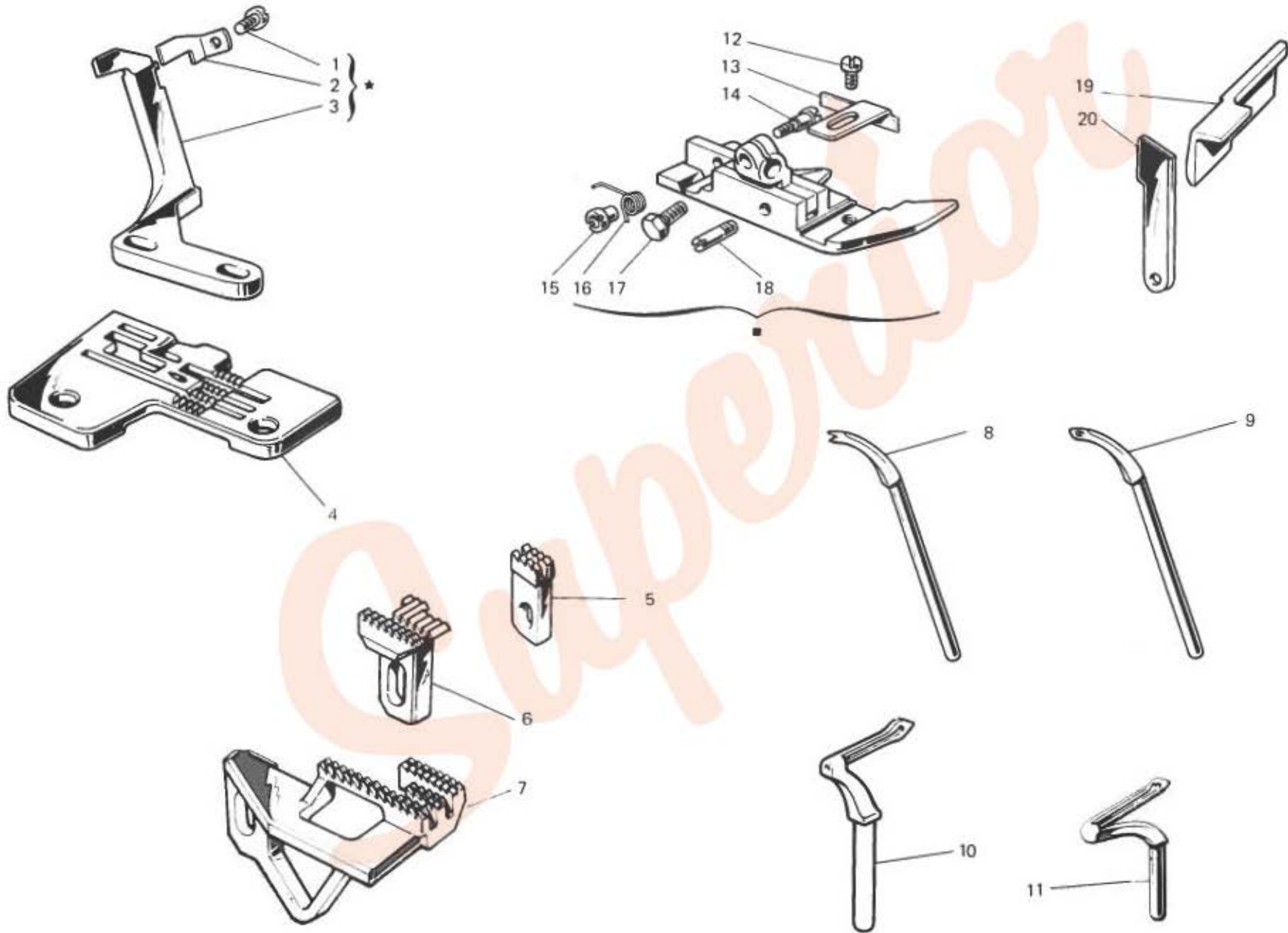

Fig. N. Abb. N.	Part. N. Bestell N. Piece N. Pieza N.	Qt. Anzahl	DESCRIZIONE	DESCRIPTION	BENENNUNG	DESCRIPTION	DESCRIPCION
★	204862-4-10	1	gruppo spingi asola e salva ago	front and rear needle guard assembly			
1	741431-0-00	1	vite	screw			
2	204863-0-10	1	salva ago	rear needle guard			
3	204861-0-10	1	spingi asola	front needle guard			
4	205025-0-10	1	placca ago	needle plate			
5	202609-0-10	1	griffino	feed-dog			
6	205065-0-10	1	griffa sussidiaria	subsidiary feed dog			
7	205060-0-10	1	griffa principale	main feed dog			
8	202092-0-10	1	crochet superiore cieco	upper looper (blind)			
9	204033-0-10	1	crochet superiore	upper looper			
10	204676-0-10	1	crochet punto sicurezza	looper			
11	202413-0-10	1	crochet inferiore	lower looper			
12	741413-0-00	1	vite	screw			
13	204878-0-10	1	piastrina	plate			
14	204889-0-10	1	vite	screw			
15	204895-0-10	1	bussola filettata	bush			
16	204894-0-10	1	molla	spring			
17	204947-0-10	1	vite	screw			
18	204869-0-10	1	spina	pin			
19	207003-2-00	1	coltello superiore	upper knife			
20	207020-2-01	1	coltello inferiore	lower knife			
■	205118-3-11	1	pedino completo	presserfoot assembly			
			SOLO A RICHIESTA	ONLY ON REQUEST			
6	205011-0-10	1	griffa sussidiaria	subsidiary feed-dog			
	205064-0-10	1	griffa sussidiaria	subsidiary feed-dog			
	205013-2-11	1	griffa sussidiaria	subsidiary feed-dog			
7	205007-0-10	1	griffa principale	main feed-dog			
	205059-0-10	1	griffa principale	main feed-dog			
	205009-2-11	1	griffa principale	main feed-dog			
19	203783-0-10	1	coltello superiore	upper knife			
	203759-0-10	1	coltello superiore	upper knife			
	207004-2-00	1	coltello superiore con placchetta	upper knife with plate			
20	204693-0-11	1	coltello inferiore	lower knife			
■	205070-3-11	1	pedino compl	presserfoot assembly			

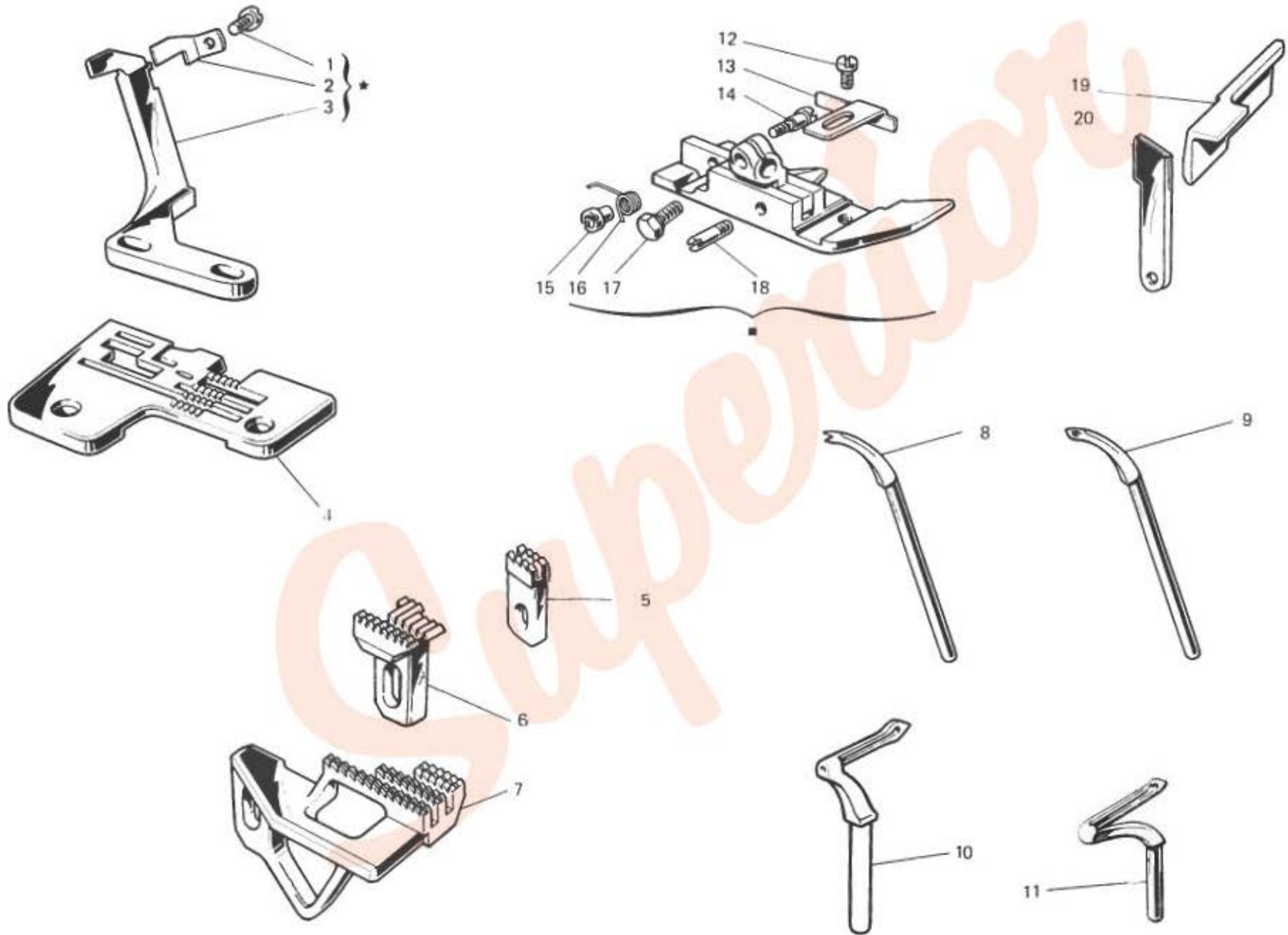

Fig. N. Abb. N.	Part. N. Bestell N. Pieze N. Pieza N.	Qt. Anzahl	DESCRIZIONE	DESCRIPTION	BENENNUNG	DESCRIPTION	DESCRIPCION
★	204862-4-10	1	gruppo spingi asola e salva ago	front and rear needle guard assembly			
1	741431-0-00	1	vite	screw			
2	204863-0-10	1	salva ago	rear needle guard			
3	204861-0-10	1	spingi asola	front needle guard			
4	204864-0-10	1	placca ago	needle plate			
5	206609-0-10	1	griffino	feed-dog			
6	204943-0-11	1	griffa sussidiaria	subsidiary feed-dog			
7	204941-0-10	1	griffa principale	main feed-dog			
8	202092-0-10	1	crochet superiore cieco	upper looper (blind)			
9	204033-0-10	1	crochet superiore	upper looper			
10	204675-0-10	1	crochet punto sicurezza	looper			
11	202413-0-10	1	crochet inferiore	lower looper			
12	741413-0-00	1	vite	screw			
13	204878-0-10	1	piastrina	plate			
14	204889-0-10	1	vite	screw			
15	204895-0-10	1	bussola filettata	bush			
16	204894-0-10	1	molla	spring			
17	204947-0-10	1	vite	screw			
18	204869-0-10	1	spina	pin			
19	207003-2-00	1	coltello superiore	upper knife			
20	207020-2-00	1	coltello inferiore	lower knife			
■	206002-3-00	1	pedino completo	presserfoot assembly			
			SOLO A RICHIESTA	ONLY ON REQUEST			
4	204948-0-10	1	placca ago	needle plate			
6	204851-0-11	1	griffa sussidiaria	subsidiary feed-dog			
	204942-0-10	1	griffa sussidiaria	subsidiary feed-dog			
	204850-0-10	1	griffa sussidiaria	subsidiary feed-dog			
7	204940-0-10	1	griffa principale	main feed-dog			
	204846-0-10	1	griffa principale	main feed-dog			
	204997-0-00	1	griffa principale	main feed-dog			
10	204676-0-10	1	crochet punto sicurezza	looper			
19	203783-0-10	1	coltello superiore	upper knife			
	203759-0-10	1	coltello superiore	upper knife			
	207004-2-00	1	coltello superiore con placchetta	upper knife with plate			
20	204693-0-11	1	coltello inferiore	lower knife			

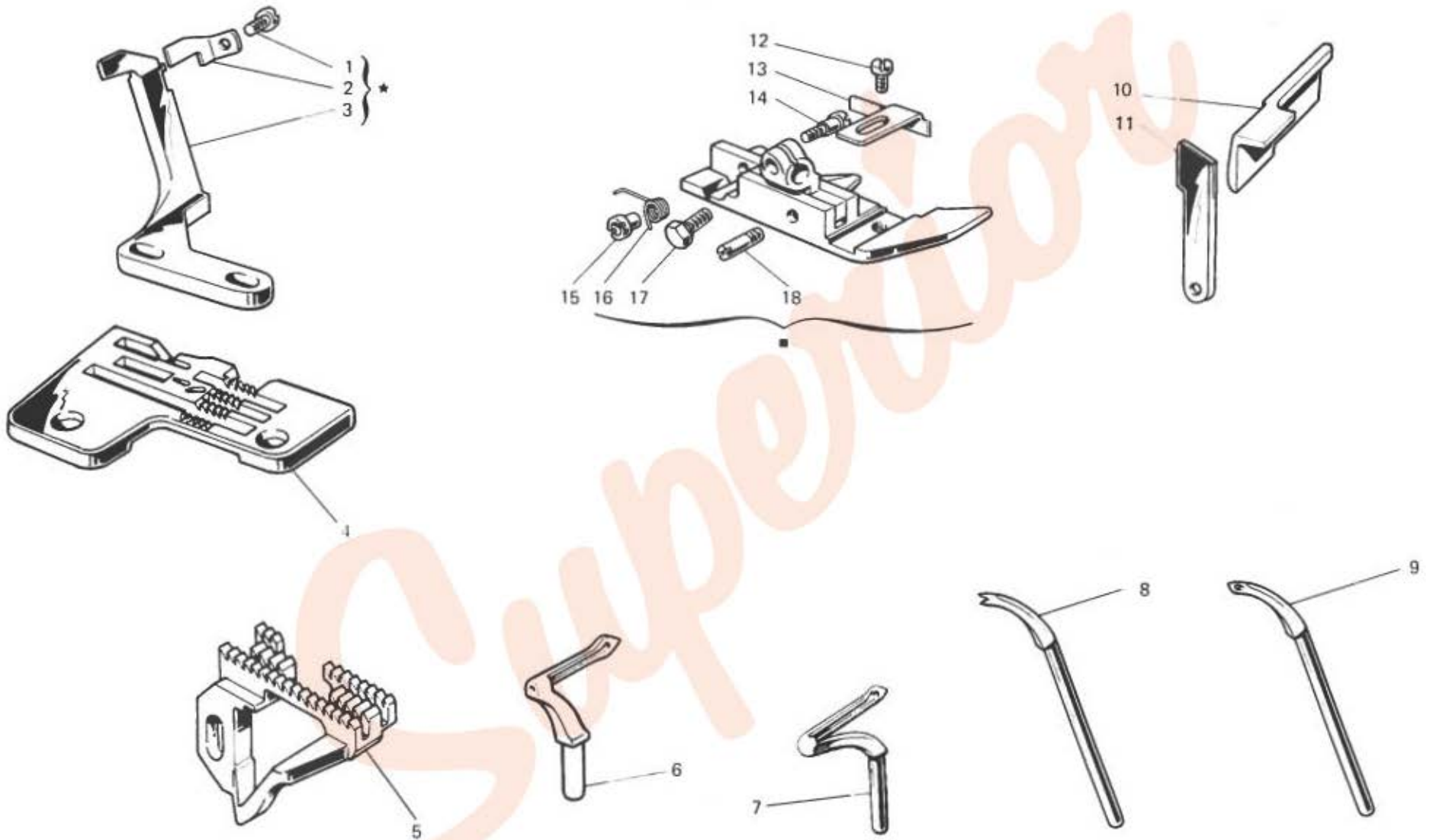

Fig. N. Abb. N.	Part. N. Bestell N. Pieze N. Pieza N.	Qt. Anzahl	DESCRIZIONE	DESCRIPTION	BENENNUNG	DESCRIPTION	DESCRIPCION
★	206051-4-10	1	gruppo spingi asola e salva ago	front and rear needle guard assembly			
1	741431-0-00	1	vite	screw			
2	204863-0-10	1	salva ago	rear needle guard			
3	206050-0-10	1	spingi asola	front needle guard			
4	206042-0-10	1	placca ago	needle plate			
5	206044-0-10	1	griffa unica	feed-dog			
6	206048-0-10	2	crochet punto sicurezza	looper			
7	202413-0-10	1	crochet inferiore	lower looper			
8	202092-0-10	1	crochet superiore cieco	upper looper (blind)			
9	204033-0-10	1	crochet superiore	upper looper			
10	207003-2-00	1	coltello superiore	upper knife			
11	207021-2-01	1	coltello inferiore	lower knife			
12	741413-0-00	1	vite	screw			
13	204878-0-10	1	piastrina	plate			
14	204889-0-10	1	vite	screw			
15	204895-0-10	1	bussola filettata	bush			
16	204894-0-10	1	molla	spring			
17	204947-0-10	1	vite	screw			
18	204869-0-10	1	spina	pin			
■	206046-3-01	1	pedino completo	presserfoot assembly			
			SOLO A RICHIESTA	ONLY ON REQUEST			
19	203783-0-10	1	coltello superiore	upper knife			
	203759-0-10	1	coltello superiore	upper knife			
	207004-2-00	1	coltello superiore con placchetta	upper knife with plate			
20	206062-0-01	1	coltello inferiore	lower knife			

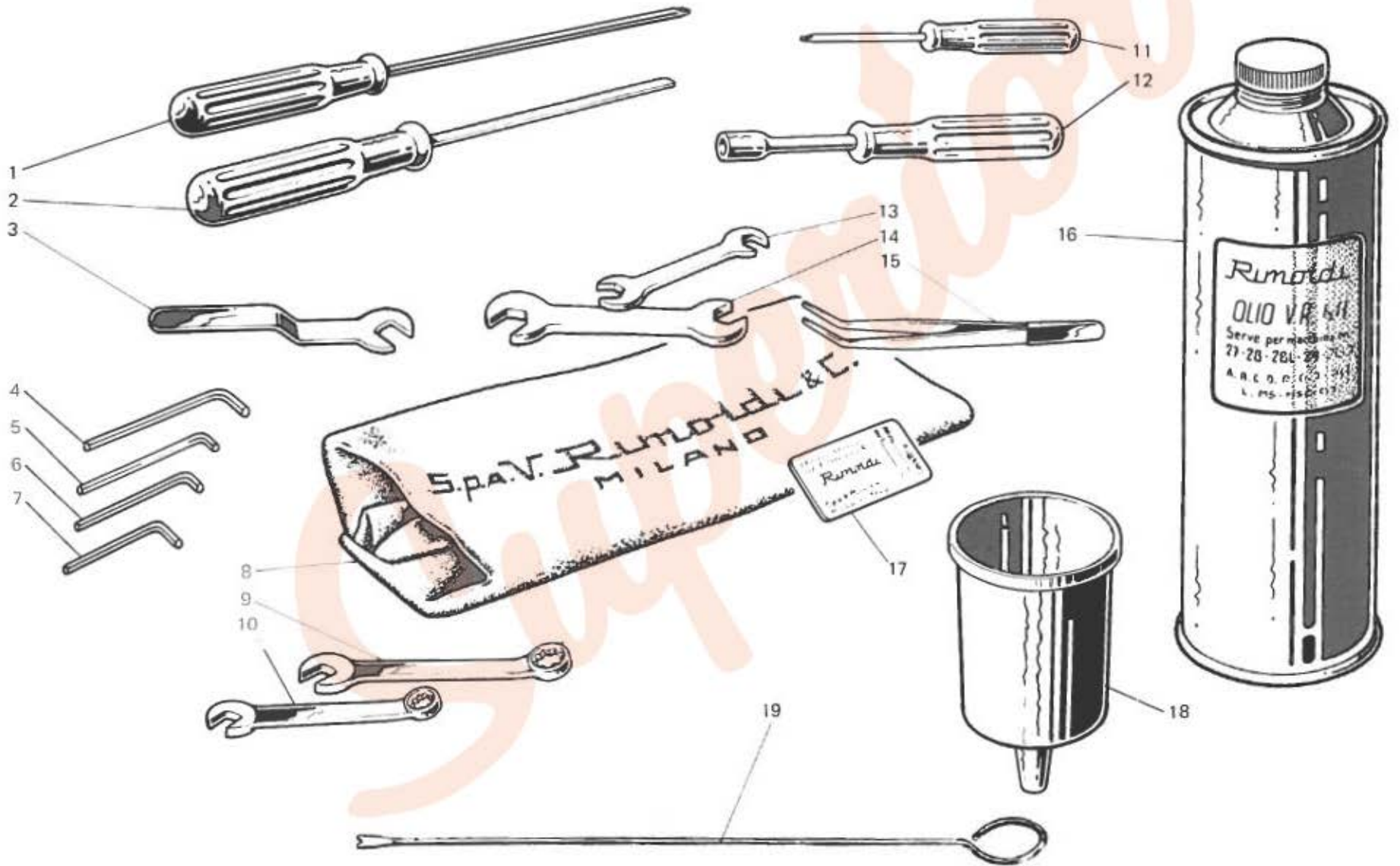

Fig. N. Abb. N.	Part. N. Bestell N. Piece N. Pieza N.	Qt. Anzahl	DESCRIZIONE	DESCRIPTION	BENENNUNG	DESCRIPTION	DESCRIPCION
1	990180-0-10	1	cacciavite grande	screwdriver			
2	990181-0-10	1	cacciavite medio	screwdriver			
3	990327-0-10	1	chiave da 7 mm.	7 mm key			
4	990639-0-10	1	chiave esag. da 3 mm.	hexagonal key			
5	990685-0-10	1	chiave esagonale da 2,5 mm.	hexagonal key			
6	990325-0-10	1	chiave esagonale da 2 mm.	hexagonal key			
7	990474-0-10	1	chiave esagonale da 1,5 mm.	hexagonal key			
8	990183-0-12	1	cuffia protezione testa	machine cover			
9	990622-0-10	1	chiave poligonale da 9 mm.	9 mm. key			
10	990624-0-00	1	chiave poligonale da 7 mm.	7 mm key			
11	990182-0-10	1	cacciavite piccolo	screwdriver			
12	990324-0-10	1	chiave a tubo da 7 mm.	7 mm key			
13	990585-0-10	1	chiave fissa da 4-5 mm.	4-5 mm key			
14	990174-0-10	1	chiave da 7-9 mm.	7-9 mm key			
15	990176-0-10	1	pinza per infilatura	threading tweezers			
16	990074-1-10	1	lattina olio da 1 Kg.	oil container			
17	765200-6-11	10	aghi sist.Rim27 fin 110	needle Rim 27 fin 110			
18	990985-0-00	1	imbuto	oil funnel			
19	990577-0-10	1	astina infilatura	threading rod			
17	765200-6-90	10	VARIANTE PER 329-00-2CD-12 aghi sist.Rim27 fin.90	VARIATION FOR 329-00-2CD-12 needle Rim27 fin.90			
17	765200-6-12	10	VARIANTE PER 329-00-3MU-01 aghi sist.Rim27 fin 120	VARIATION FOR 329-00-3MU-01 needle Rim27 fin.120			

PIAZZAMENTO NORMALE
NORMAL SETTING

PIAZZAMENTO INCASSATO
SUBMERGED SETTING

PER PIAZZAMENTO CON MOTORE QUICK STOP TIPO D
FOR SETTING WITH QUICK STOP ENGINE TYPE D

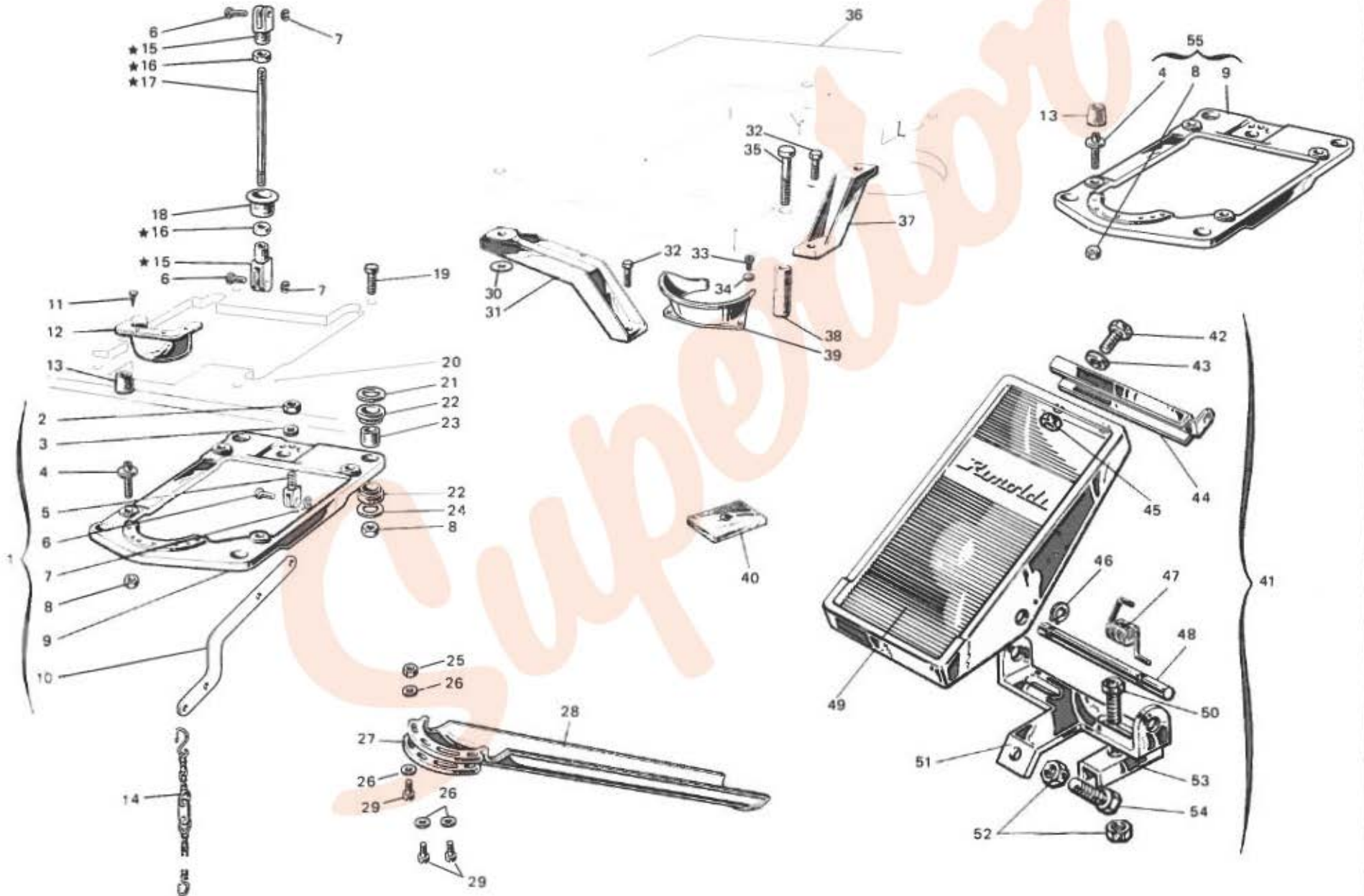

Fig. N. Abb. N.	Part. N. Bestell N. Piece N. Pieza N.	Qt. Anzahl	DESCRIZIONE	DESCRIPTION	BENENNUNG	DESCRIPTION	DESCRIPCION
★	990984-4-00	1	PIAZZAMENTO NORMALE	NORMAL SETTING			
1	990986-4-00	1	tirante alza piedino	rod			
2	746409-2-00	1	supporto testa completo	head support assembly			
3	704424-2-00	1	dado	nut			
4	900694-0-11	1	rondella	washer			
5	990314-0-00	4	perno	pin			
6	990311-0-10	1	supportino per leva	support			
7	700205-0-00	3	perno	pin			
8	733008-2-00	3	anello elastico	spring ring			
9	990981-0-00	8	dado	nut			
10	990316-0-10	1	piastra supporto testa	support plate			
11	990316-0-10	1	leva comando alza piedino	lever			
12	900201-0-10	4	chiodino	rivet			
13	991187-0-00	1	bocchetta scarica ritagli	offlet			
14	990982-0-00	4	ammortizzatore	shock absorber			
15	990179-4-11	1	catenella	chain			
16	990310-0-10	2	giunto	joint			
17	746402-0-00	2	dado	nut			
18	990983-0-00	1	tirante	rod			
19	900204-0-10	1	bussola	bush			
20	722905-2-00	4	vite	screw			
21	901120-2-00	1	tavola	table			
22	704346-2-00	4	rondella	washer			
23	901101-0-00	8	ammortizzatore	shock absorber			
24	901102-0-00	4	bussola	bush			
25	704345-2-00	4	rondella	washer			
55	990987-4-00	1	supporto testa completo solo per motore Quick Stop-tipo D	head support assembly-only for Quick Stop (type D) engine			
			VARIANTE PER PIAZZAMENTO INCASSATO	VARIATION FOR SUBMERGED SETTING			
30	704536-0-00	2	rondella	washer			
31	901105-0-00	1	staffa laterale	bracket			
32	720566-2-00	2	vite	screw			
33	721475-2-00	2	vite	screw			
34	704409-2-00	2	rondella	washer			
35	722917-2-00	2	vite	screw			
36	901123-4-00	1	tavola	table			
37	901104-0-00	1	staffa posteriore	rear bracket			
38	901103-0-00	2	distanziale	spacer			
39	991188-0-00	1	bocchetta scarica ritagli	offlet			

PIAZZAMENTO NORMALE
NORMAL SETTING

PIAZZAMENTO INCASSATO
SUBMERGED SETTING

PER PIAZZAMENTO CON MOTORE QUICK STOP TIPO D
FOR SETTING WITH QUICK STOP ENGINE TYPE D

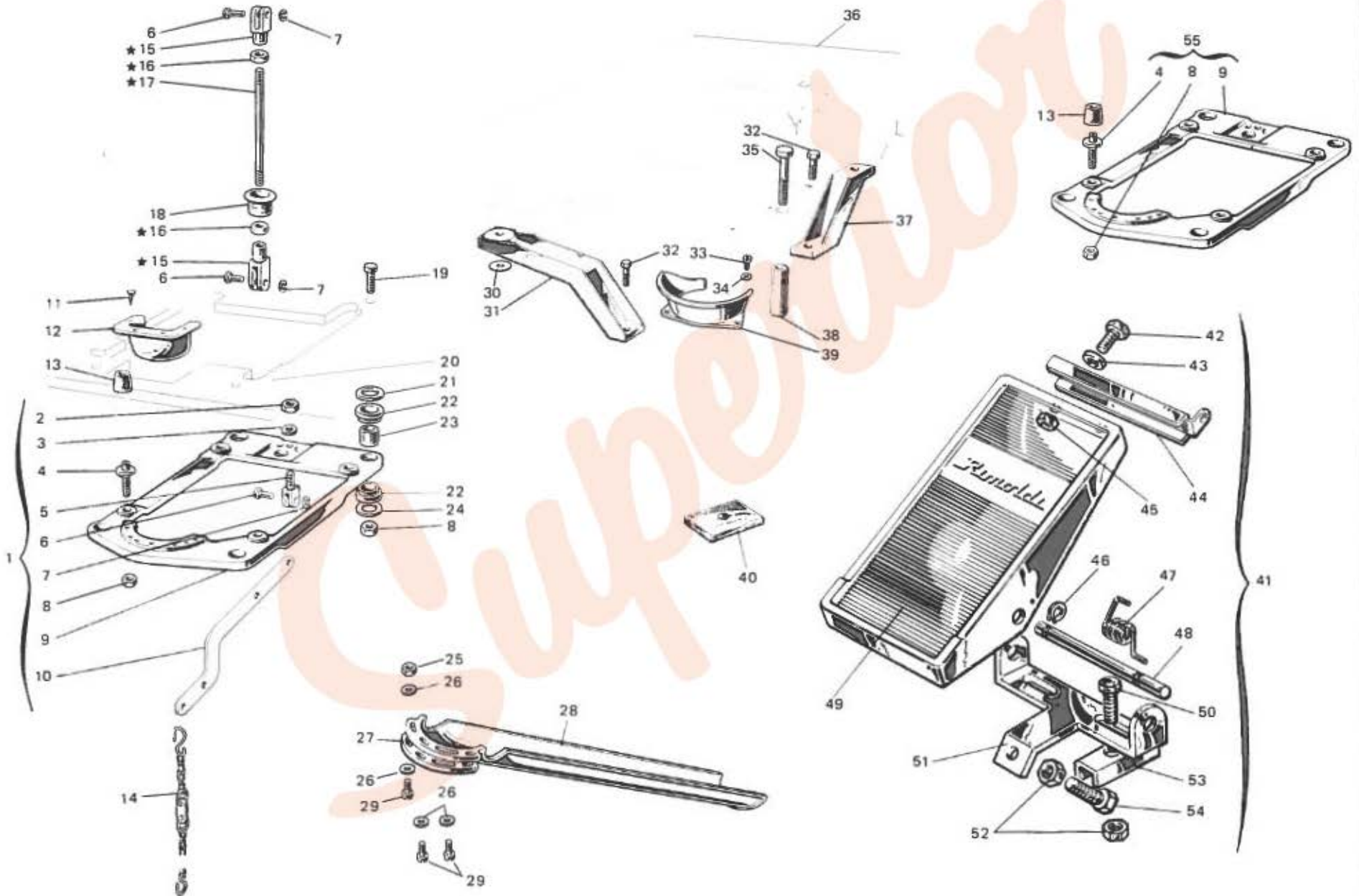

Fig. N. Abb. N.	Part. N. Bestell N. Piece N. Pieza N.	Qt. Anzahl	DESCRIZIONE	DESCRIPTION	BENENNUNG	DESCRIPTION	DESCRIPCION
			PARTICOLARI COMUNI				
				PARTS FOR BOTH SETTINGS			
25	733507-2-00	1	dado	nut			
26	704409-2-00	4	rondella	washer			
27	991189-0-00	1	piastra rinforzo	plate			
28	991186-0-00	1	conale scarica ritagli	offlet			
29	742068-2-00	3	vite	screw			
40	900203-0-10	4	ammortizzatore per tavola	shock absorber			
41	900925-4-01	1	pedalina completa	pedal assembly			
42	720464-4-00	2	vite	screw			
43	704009-4-00	2	rondella	washer			
44	900926-0-00	1	attacco	attachment			
45	733508-4-00	2	dado	nut			
46	900918-0-00	2	anello elastico	spring ring			
47	900927-0-00	1	molla	spring			
48	900928-0-00	1	perno	pin			
49	900931-0-00	1	copertura	cover			
50	720505-4-00	2	vite	screw			
51	900920-0-00	2	piastrina	plate			
52	720545-4-00	1	vite	screw			
53	733510-4-00	3	dado	nut			
54	900929-0-01	1	supporto	support			

Superior

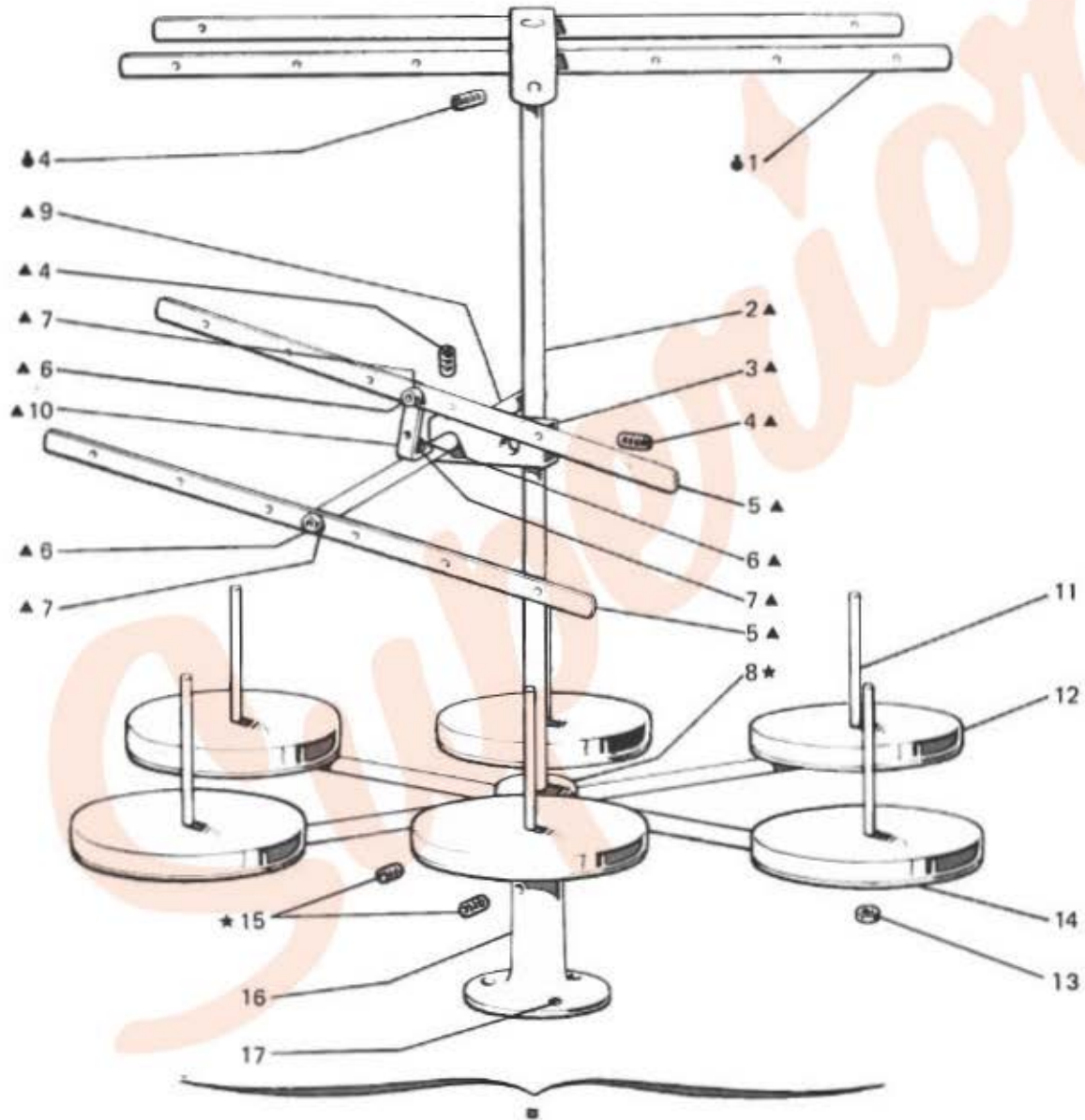

Fig. N. Abb. N.	Part. N. Bestell N. Piece N. Pieza N.	Qt. Anzahl	DESCRIZIONE	DESCRIPTION	BENENNUNG	DESCRIPTION	DESCRIPCION
■	991135-6-00	1	gruppo porta bobine (6 fili)	bobbin carrier assembly (6 threads)			
▲	991136-4-00	1	telaio supplementare completo	supplementary frame assembly			
1	991140-2-00	1	telaio	frame			
2	991113-0-00	1	asta principale	main rod			
3	991128-0-00	1	blocchetto	block			
4	729034-2-00	3	vite	screw			
5	991137-2-00	2	telaio con bussole	frame with bushes			
6	722431-2-00	3	vite	screw			
7	703005-0-00	3	rondella	washer			
8	991144-3-00	1	mozzo con aste	hub with pins			
9	991106-0-00	1	asta	rod			
10	991107-0-00	1	squadretta	bracket			
11	991111-0-00	6	astina	rod			
12	991179-0-00	6	disco antivibrante	disc			
13	733508-2-00	12	dado	nut			
14	991112-0-00	6	piatto	plate			
15	729054-2-00	3	vite	screw			
16	991114-0-00	1	basetta	base			
17	731107-0-00	3	vite a legno	screw			

Superior

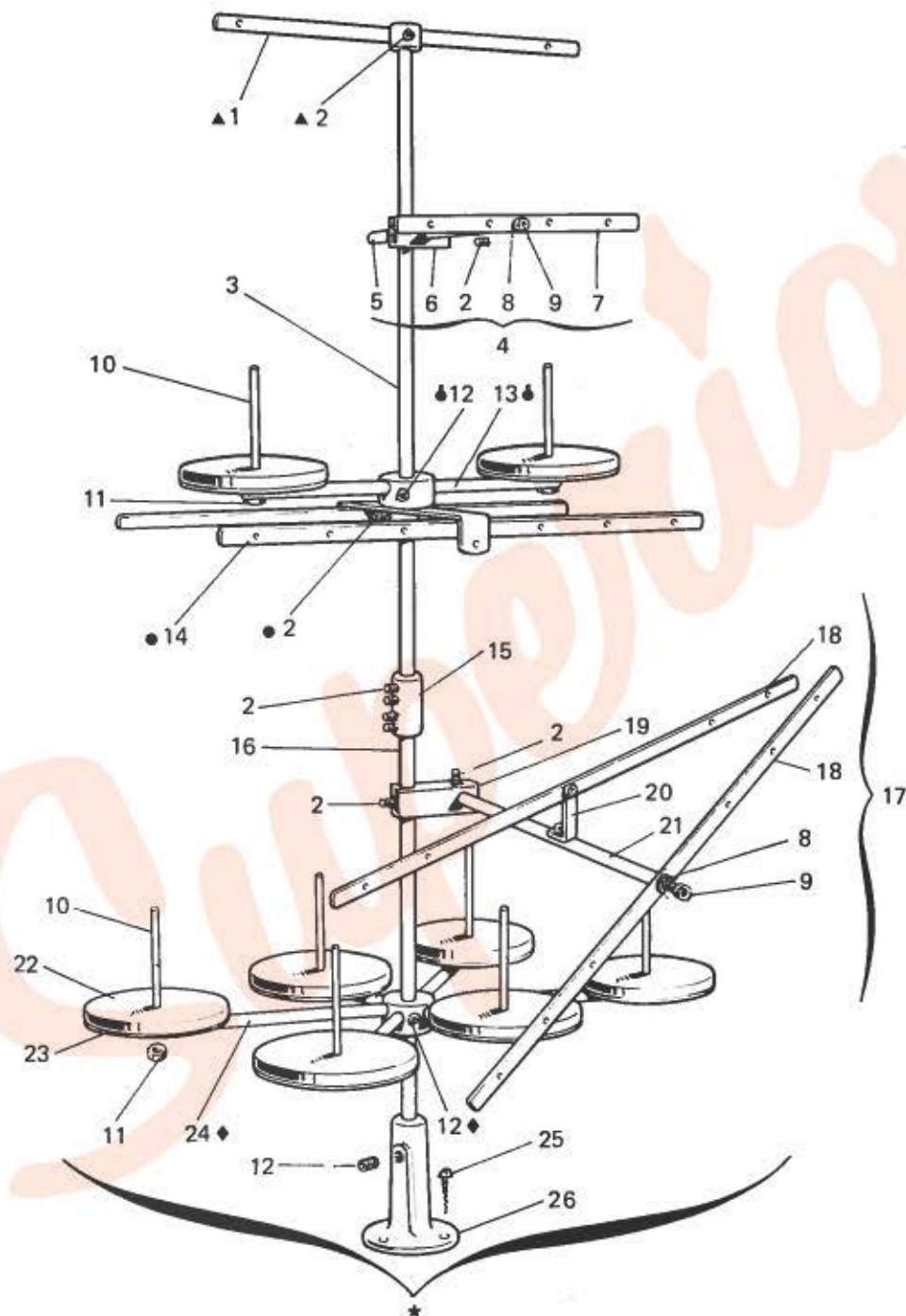

Fig. N. Abb. N.	Part. N. Bestell N. Pieze N. Pieza N.	Qt. Anzahl	DESCRIZIONE	DESCRIPTION	BENENNUNG	DESCRIPTION	DESCRIPCION
★	991160-5-00	1	portabobine completo (7-8 fili)	bobbin carrier assembly (7-8 threads)			
1	991102-2-00	1	telaio superiore completo	upper frame assembly			
2	729034-2-00	10	vite	screw			
3	991113-0-00	1	asta principale	main rod			
4	991119-4-00	1	telaio supplem. completo	supplementary frame assembly			
5	991162-0-00	1	asta	rod			
6	991110-0-00	1	blocchetto	block			
7	991108-2-00	1	telaio con bussole	frame with bushes			
8	703005-0-00	4	rondella	washer			
9	722431-2-00	4	vite	screw			
10	991111-0-00	8	astine	rod			
11	733508-2-00	16	dado	nut			
12	729054-2-00	5	vite	screw			
13	991115-3-00	1	mozzo con aste	hub with pin			
14	991139-3-00	1	telaio supplem. completo	supplementary frame assembly			
15	991163-0-00	1	giunto	joint			
16	991168-0-00	1	asta sussidiaria	subsidiary rod			
17	991164-4-00	1	telaio supplem. completo	supplementary frame assembly			
18	991166-2-00	2	telaio con bussole	frame with bushes			
19	991128-0-00	1	blocchetto	block			
20	991107-0-00	1	squadretta	bracket			
21	991165-0-00	1	asta	rod			
22	991179-0-00	8	disco antivibrante	disc			
23	991112-0-00	8	piatto	disc			
24	991144-3-00	1	mozzo con aste	hub with pins			
25	731107-0-00	3	vite a legno	screw			
26	991114-0-00	1	basetta	base			