

Rimoldi®

**SPARE PARTS CATALOGUE
CATALOGO PEZZI DI RICAMBIO
CATALOGUE RECHANGES
ERSATZTEILELISTE**

**268-00-2MD-19
268-00-2MD-31**

n. 118

This spare parts catalogue is made up of two parts: in the first one, called "basic catalogue", all the details of most representative head are listed (the first head listed on the cover); the second one includes the details of the other main heads or derived ones, which are different from that of the basic catalogue.

The main heads are listed on the cover in bigger lettering to distinguish them from the derived heads.

When you consult the catalogue will you please note that:

1. all parts which cannot be supplied by themselves are not indicated alone, but shown together with the group to which they belong;
2. the references of the pictures of the parts making up the group are usually put in brackets.
In some cases, however, when their grouping is not possible, the numbers of the various parts in the tables are marked with the same particular sign with which the whole group is indicated.

3. In the tables of the other heads there are listed all the parts not fitted on the head in the basic catalogue.

These tables are marked at the top right-hand corner with the symbol of the head which the table refers to.

The drawings in this group of tables show only the parts which are new or basically different from those fitted on the most representative head in the catalogue.

The parts which are represented only by the symbol but not illustrated keep the same figure number as the corresponding parts shown in the basic catalogue.

The parts which are common to all the heads in the catalogue are listed only in the first group of tables.

Parts marked "annulled part" are those not fitted on the head which the table refers to. When an assembly has been annulled only the assembly symbol is specified, but all the parts forming the assembly must also be considered annulled.

For each head the table for sewing parts is always repeated completely.

To make it easier to locate the parts, the reference numbers of all of those shown in the basic catalogue are listed together with the number of the table in which they are to be found.

NEEDLES

The needles are marked with system and size; the size indicates the average diameter in hundredths of a millimeter.

The system and size of the needle are shown on the packet as well as on the needle itself.

When ordering please state symbol, system and size. If you have doubts, enclose a sample needle or an empty packet with your order.

ATTENTION

When ordering spare parts always state the serial number of the machine, the symbol of the part in question and the description given in the catalogue.

Ce catalogue "pièces détachées" est formé de deux parties: la première appelée "catalogue base" comprend toutes les pièces montées sur la tête la plus significative (celle en tête de la liste de couverture), la seconde comprend toutes les pièces montées sur les autres têtes de base ou dérivées qui sont différentes de celle du "catalogue base".

Les têtes de base sont énumérées sur la couverture, en caractères plus grands que les têtes dérivées.

Lorsque l'on consulte le catalogue, se souvenir que:

1. Toutes les pièces qui ne sont pas fournies séparément mais qui font partie d'un groupe, ne sont pas indiquées séparément.
2. Les symboles des pièces qui forment un groupe sont regroupés entre parenthèses. Cependant, lorsque ceci n'a pas été possible, les symboles, qui dans les tables d'illustration correspondent aux pièces, sont suivis du même signe particulier qui indique le groupe tout entier.

3. Dans les tables relatives aux autres têtes, nous avons indiqué toutes les pièces différentes de celles de tête du "catalogue base" ou qui ne sont pas montées sur ces dernières. Ces tables portent, en haut à droite, le symbole des têtes auxquelles elles se réfèrent (pour les dérivées, le symbole de la tête de laquelle elles dérivent est indiqué entre parenthèses).

Les dessins de ce groupe de tables représentent seulement les nouvelles pièces ou celles qui sont différentes des pièces montées sur la tête la plus significative du catalogue.

Les pièces indiquées par un symbole, mais qui ne sont pas illustrées, gardent le même numéro de dessin que celles correspondantes, illustrées sur le catalogue base.

Les pièces communes à toutes les têtes du catalogue, sont indiquées seulement dans le premier groupe de tables.

Les pièces définies comme "pièces annulées" sont celles qui ne sont pas montées sur la tête à laquelle se réfère la table. Dans le cas de l'annulation d'un groupe, nous indiquons seulement le symbole du groupe, mais toutes les pièces qui forment ce groupe sont annulées.

Pour chaque tête est toujours indiquée la table se référant aux organes de couture.

Pour faciliter la recherche, le catalogue renferme l'index numérique de toutes les pièces illustrées avec indication de la table dans laquelle elles sont indiquées.

AIGUILLES

Les aiguilles se différencient par le système et la grosseur, laquelle indique le diamètre moyen exprimé en centièmes de millimètre.

Le système de l'aiguille et sa grosseur, sont indiqués non seulement sur le sachet mais également sur l'aiguille.

Dans la commande, préciser, en plus du symbole, le système et la grosseur des aiguilles désirées. En cas de doute, joindre une aiguille comme modèle ou un sachet vide.

ATTENTION

Dans la commande de pièces détachées, indiquer toujours le numéro de la machine, le symbole de la pièce et la dénomination officielle mentionnée sur le catalogue.

Rumoldi

SIMBOLO SYMBOL SYMBOLE	CARATTERISTICHE TESTE	MACHINE HEAD FEATURES	CARACTERISTIQUES TETES
268-00-2MD-19	<p>Per fissare al sacco di fodera delle tasche dei pantaloni, le due strisce di tessuto riportate sull'apertura della tasca stessa, in una sola operazione. Indicate anche per orlature con controllo visivo della copertura dell'orlo, mediante guida a squadra spostabile e per applicazione di rinforzi su slips, mutandine ecc. ecc. in tessuti a maglia o felpati. Esegue una cucitura speciale a due ranghi a punto a catenella doppia (401) con copertura superiore. Con differenziale.</p>	<p>For attaching, in one operation only, to the pocket lining of trousers, two facings visible on the pocket opening. Suitable also for hemming with visual control of hem-covering seam by means of a movable edge guide and for attaching gussets to briefs, panties, etc. made from knit or fleecy-lined fabrics. This machine makes a special seam with two rows of double locked chain stitching (seam No. 401) with top covering. With differential feed.</p>	<p>Pour appliquer à la doublure des poches des pantalons deux bandes de tissu rapportées sur l'ouverture de la poche même, en une seule opération. Elle est également employée pour exécuter un ourlage avec contrôle visuel de l'ourlet à l'aide d'un guide à équerre déplaçable, ainsi que pour appliquer des bandes de renfort sur des slips, culottes, etc. en tissu à mailles ou molleton. Elle exécute une couture particulière avec deux rangées à point de chaînette double (401) avec couverture supérieure. Avec transport différentiel.</p>
268-00-2MD-31	<p>Come la 268-00-2MD-19 ma con distanza aghi 6 mm.</p>	<p>Same as 268-00-2MD-19, but with 6 mm needle gauge.</p>	<p>Comme la 268-00-2MD-19, mais avec écartement aiguilles 6 mm.</p>

Rumoldt

INDICE NUMERICO INDEX

Part. N.	Tav. N.	Part. N.	Tav. N.	Part. N.	Tav. N.	Part. N.	Tav. N.	Part. N.	Tav. N.	Part. N.	Tav. N.	Part. N.	Tav. N.
100174-0-10	15	300391-0-10	2	302353-0-10	3	308038-0-10	9	308104-0-00	14	308199-0-00	5	308297-0-00	1
200324-0-10	2	300419-0-10	14	302354-0-10	3	308039-0-01	9	308105-4-00	14	308203-0-01	2	308298-0-00	1
200710-0-10	12	300420-0-10	14	302355-0-10	3	308040-2-00	14	308110-3-00	14	308207-0-00	14	308310-0-00	5
200714-0-10	12	300469-2-11	7	302356-0-10	1	308041-0-00	9	308111-0-00	14	308211-0-00	14	308320-4-00	12
200853-0-10	14	300482-0-10	7-8	303045-0-10	2	308042-0-00	9	308113-0-00	13	308212-0-00	14	308321-0-00	12
201128-0-10	9	300483-0-10	2-3	303458-0-12	6	308043-0-00	14	308114-2-01	14	308214-0-00	14	308325-3-00	8
201143-0-10	4	300917-0-10	15	303459-2-11	4	308044-0-00	8	308119-0-00	4	308215-0-00	1	308326-2-01	8
201236-0-10	2	301050-0-11	15	303501-0-10	1	308045-0-01	8	308123-0-00	14	308218-0-00	1	308327-0-00	8
202032-0-11	9	301225-0-10	15	303503-0-10	7	308046-2-01	8	308125-0-00	13	308221-0-00	9	308330-3-00	8
202165-0-10	3	301384-0-12	15	303538-0-00	7	308047-0-00	8	308126-0-00	13	308226-0-01	13	308334-0-00	8
202229-0-10	12	301386-0-10	15	303539-0-00	7	308051-0-01	1	308127-0-00	5	308228-2-00	13	308340-4-00	4
202239-0-10	3	301391-0-20	15	303664-0-11	15	308054-0-00	10	308128-0-00	3	308231-2-01	13	308346-5-00	4
202474-0-10	7	301392-3-11	15	303665-0-11	15	308055-2-00	10	308129-0-00	3	308232-0-00	1	308358-4-00	6
202486-0-10	4	301394-0-10	15	303669-0-11	9	308056-0-00	10	308137-0-00	2	308233-0-00	9	308381-2-00	6
202487-0-10	10	301458-0-10	4	303670-4-12	9	308057-0-00	10	308138-0-02	1	308234-2-00	9	308407-4-00	5
202556-0-00	12	301459-4-10	4	303677-0-01	15	308058-0-00	10	308139-2-01	9	308235-0-00	9	308410-0-00	5
202558-2-00	12	301519-2-11	4	303679-3-01	15	308059-0-00	10	308140-0-00	7	308236-2-00	9	308412-2-00	10
206545-0-00	13	301579-0-10	4	303899-0-10	9	308060-4-00	10	308148-0-00	10	308238-4-00	9	308461-0-00	3
206551-0-00	14	301596-0-11	15	304763-0-10	12	308061-0-01	10	308149-0-01	5	308239-0-00	9	308458-3-00	8
206552-2-00	14	301598-0-11	15	304767-2-10	10	308062-2-00	12	308150-0-10	13	308243-3-00	14	308459-4-00	8
206555-0-00	14	302028-0-11	4	304905-0-10	2	308065-2-00	11	308151-0-00	13	308244-4-00	9	308462-0-00	3
206557-0-00	14	302052-2-21	7	305194-0-00	8	308067-0-00	11	308153-0-00	14	308253-3-00	5	308495-2-00	12
206559-0-00	13	302059-0-10	10	307136-0-00	2	308071-3-00	11	308154-0-00	14	308263-4-00	7	308501-0-01	12
206560-0-10	13	302060-0-11	10	307394-2-10	2	308072-2-00	11	308155-4-00	14	308268-2-00	7	308502-0-00	12
206564-0-00	13	302136-0-11	2	307395-4-01	2	308073-0-00	11	308159-2-01	5	308271-0-00	7	308503-0-01	12
206583-0-00	9	302149-0-11	2	307396-0-10	2	308074-0-00	1	308161-0-00	5	308272-0-00	7	308504-0-00	12
206669-2-01	14	302152-0-10	4	308002-0-00	13	308075-0-00	11	308162-0-00	5	308273-0-00	7	308505-0-00	12
300006-0-11	3	302168-2-10	2	308006-0-00	9	308076-2-01	10	308166-0-00	5	308275-2-00	4	308506-0-00	12
300209-0-10	4	302172-0-10	2	308006-4-00	9	308077-2-00	11	308174-3-00	5	308276-0-00	4	308507-0-00	12
300218-0-10	12	302204-0-10	2	308007-0-00	10	308078-0-00	11	308178-4-00	5	308278-0-00	6	308512-0-00	12
300228-0-10	4	302232-0-10	12	308009-0-00	1	308079-4-00	11	308180-2-00	14	308280-0-00	6	308518-4-00	12
300231-0-10	4	302234-0-10	10	308012-2-00	5	308081-4-00	11	308184-0-00	14	308281-0-00	6	308521-4-00	12
300310-0-10	2	302238-0-10	12	308013-4-00	5	308082-2-00	11	308185-0-00	14	308284-2-00	4	308527-4-00	12
300348-0-10	9	302272-0-10	5	308015-0-00	6	308084-2-00	5	308190-0-00	4	308285-0-00	4	308551-0-00	2
300351-0-11	8	302276-0-10	7	308029-2-00	4	308086-0-00	1	308191-4-00	4	308286-4-00	4	308553-2-00	2
300352-0-10	8	302289-0-10	8	308030-2-00	4	308092-0-00	11	308192-4-00	4	308287-0-00	4	308556-0-00	2
300361-0-10	4	302292-0-10	9	308031-0-00	1	308096-0-00	1	308193-2-00	4	308289-2-00	4	308558-0-00	2
300362-0-11	4	302338-0-10	9	308032-0-00	1	308098-0-00	10	308194-0-00	4	308291-0-01	7	308576-2-01	13
300364-0-10	4	302344-0-10	10	308035-0-00	5	308101-2-00	3	308195-0-00	4	308292-4-00	7	308588-4-01	13
300371-0-10	4	302347-0-10	11	308036-2-00	9	308102-0-10	3	308196-0-00	4	308293-0-00	1	308600-3-00	1
300377-0-10	4	302352-0-10	9	308037-0-00	9	308103-4-00	9	308199-0-00	5	308296-0-00	1	308714-3-00	6

Part. N.	Tav. N.	Part. N.	Tav. N.	Part. N.	Tav. N.	Part. N.	Tav. N.	Part. N.	Tav. N.	Part. N.	Tav. N.	Part. N.	Tav. N.
308750-2-00	11	309704-4-00	6	704828-0-00	9	727834-2-00	4-12	741658-2-00	3-11	778412-0-00	4	990982-0-00	17-18
308753-0-00	11	309759-2-00	9	704834-0-00	11	728232-0-00	4	741675-2-00	8	778415-0-00	4	991106-2-00	19
308783-2-00	3	309768-0-00	9	704835-0-00	11	729011-2-00	2-4	741682-0-00	2	778502-0-00	11	991107-2-00	19
308802-0-00	5	309830-2-00	9	704846-0-00	4-7	729013-2-00	4-9	741724-0-00	11	778544-0-00	9	991111-2-00	19
308851-2-00	9	309831-2-00	9	704849-0-00	8	729032-2-00	1	741928-0-00	4	778827-0-00	7	991112-0-00	19
308852-0-00	1	309838-2-00	4	704869-0-00	5-9	729034-2-00	12-19	741937-0-00	2	785755-0-20	15	991113-0-00	19
308853-0-00	1	309839-2-00	4	705008-0-00	4	729044-2-00	5	741984-2-00	5	788020-0-01	3	991114-2-00	19
308855-0-00	9-11	309851-4-00	9	705013-0-00	5-9-11	729051-2-00	11	742214-2-00	7	790242-0-00	14	991128-2-00	19
308858-0-00	1	310013-4-00	15	705201-0-00	2	729054-2-00	19	742222-2-00	5	790307-0-00	14	991135-5-00	19
308859-2-00	1	310350-4-00	5	705208-0-00	9	729434-2-00	8	742282-2-00	3	790315-0-00	14	991137-2-00	19
308860-0-00	11	310500-4-00	14	705734-0-00	7	729884-2-00	12	742311-2-00	9	790325-0-00	14	991139-3-00	19
308861-0-00	11	311098-0-00	2	705834-0-00	8	730011-2-00	14	742423-0-00	7	790342-0-00	14	991144-3-00	19
308862-0-00	11	700205-0-00	10	705970-0-00	3	730033-2-00	7-9-11	742623-2-00	1	900201-0-10	17	991179-0-00	19
308863-0-00	11	700208-0-00	17-18	705977-0-00	13	730054-2-00	5	742811-0-00	4	900203-0-10	17-18	991250-0-00	17-18
308864-4-00	11	700596-0-00	5	706434-0-00	4	731107-2-00	19	742813-0-00	4	900204-0-10	18	991251-4-00	17
308865-2-00	11	701004-0-00	14	706454-0-00	1	733008-2-00	17	743265-2-00	15	900918-0-00	17-18	991252-4-00	18
308867-4-00	11	701007-0-00	12	707241-0-00	12	733507-0-00	14	743541-2-00	17-18	900920-0-00	17-18	991253-4-00	17
308868-2-00	11	701009-0-00	8	720464-0-00	17-18	733508-2-00	19	744040-2-00	8	900925-4-01	17-18	991254-4-00	18
308869-0-00	11	701032-0-00	14	720505-4-00	17-18	733508-4-00	17-18	744636-2-00	3	900926-0-00	17-18	991255-0-00	17-18
308890-0-00	2	701051-0-00	13	720545-4-00	17-18	733510-4-00	17-18	744656-2-00	3	900927-0-00	17-18	991256-0-00	17-18
308938-4-00	2	702403-0-00	7	720546-0-00	18	733813-0-00	17-18	744676-2-00	8-12	900928-0-00	17-18	991257-0-00	17-18
308967-2-00	4	703003-0-00	13	721410-0-00	11	740210-2-00	2	744730-0-00	3	900929-0-01	17-18	991259-3-00	17-18
308971-3-00	4	703005-0-00	9-19	721424-0-00	3	740220-2-00	2	745001-0-00	9	900931-0-00	17-18	991408-4-00	16
308996-0-01	12	703810-0-00	7-10	721424-2-00	14	740226-0-00	7-11	745126-2-00	12	901101-0-00	17-18	991415-0-00	16
309042-2-00	3	704009-0-00	17-18	721444-2-00	1-2-4	740238-0-00	11	745136-2-00	4	901102-0-00	17-18		
309051-0-00	3	704210-4-00	2-9	721464-2-00	13	740240-0-00	13	745800-2-00	2-9-11	901251-2-00	18		
309059-4-00	3	704218-2-00	2-4	721474-2-00	3	740243-0-00	4	745810-2-00	9	901253-0-00	18		
309084-0-00	3	704226-2-00	7	721475-2-00	3	740257-0-00	4	745812-2-00	5-9-10-11	990074-1-11	16		
309086-0-01	3	704240-2-00	12	721485-2-00	1	740444-2-00	10	745815-2-00	4-5-7-8	990075-1-11	16		
309088-0-00	3	704302-4-00	2	721494-2-00	10-11-14	740475-2-00	4	745827-2-00	6-10	990175-0-10	18		
309126-3-00	3	704306-0-01	3	721514-0-00	14	740632-2-00	10-12	746007-2-00	11	990176-0-10	18		
309139-4-00	3	704309-4-00	8-11	722422-2-00	9	740636-2-00	12	746008-0-00	9	990179-4-11	17-18		
309177-3-00	3	704310-2-00	17-18	722431-2-00	19	741058-0-00	5	746204-0-00	12	990181-0-10	16		
309227-0-00	3	704316-2-00	17-18	722453-2-00	13	741082-2-00	14	746408-2-00	5-9-11	990182-0-10	16		
309302-2-00	3	704345-2-00	17-18	722905-2-00	17	741088-2-00	3	746409-2-00	17-18	990188-0-10	16		
309323-0-00	3	704346-2-00	17-18	722907-2-00	18	741092-0-00	14	746612-2-00	6	990193-0-00	16		
309324-2-00	3	704347-0-00	4	722920-2-00	18	741413-2-00	2	766000-6-90	9	990317-0-10	17		
309360-0-00	3	704406-0-00	4	724420-2-00	2	741546-2-00	4	778203-0-00	9	990474-0-10	16		
309371-0-00	3	704805-0-00	4	724441-0-00	6	741612-0-00	2	778204-0-00	11	990578-0-12	16		
309372-0-00	3	704813-0-00	14	724442-2-00	3	741620-2-00	9	778238-0-00	4	990587-0-10	16		
309560-0-00	4	704814-0-00	6	727215-0-00	4	741642-2-00	2	778240-0-00	4	990694-0-11	17		

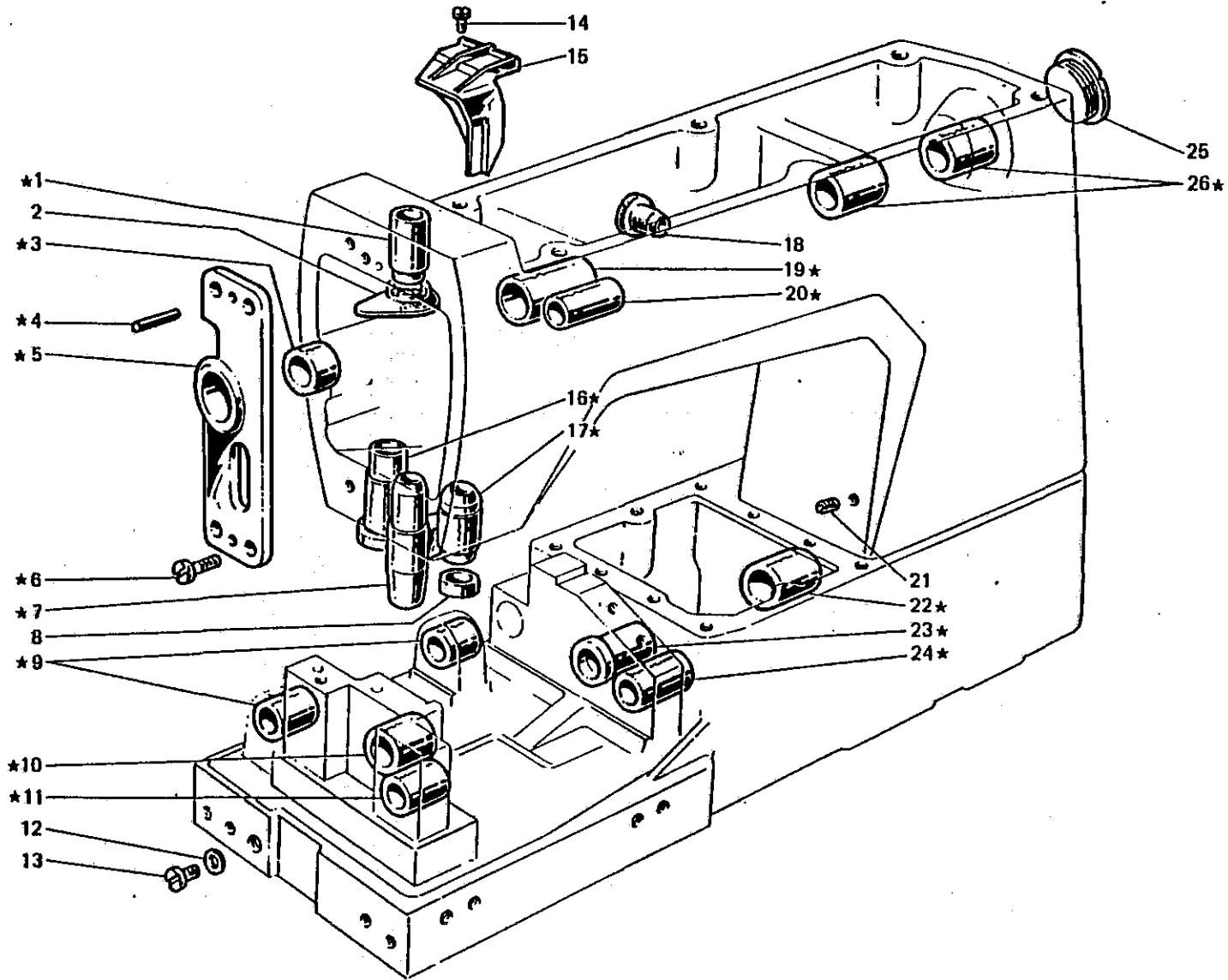

Fig. N. Abb. N.	Part. N. Bestell N. Piece N. Pieza N.	Qt. Pezzi	DESCRIZIONE	DESCRIPTION	DESCRIPTION	BENENNUNG	DESCRIPCION
★	308600-3-00	1	base e braccio con bussole	base and arm with bushes	base et bras avec bagues		
1	308032-0-00	1	bussola	bush	bague		
2	308215-0-00	1	protezione olio	oil protection	protection huile		
3	308858-0-00	1	bussola	bush	bague		
4	706454-0-00	2	spina	pin	goupille		
6	308859-2-00	1	supporto con bussola fig. 3	support with bush fig. 3	support avec bague fig. 3		
6	721485-2-00	4	vite	screw	vis		
7	308051-0-01	1	bussola	bush	bague		
8	308218-0-00	1	scodellino inferiore	lower cup	cuvette inférieure		
9	308296-0-00	2	bussola	bush	bague		
10	308293-0-00	1	bussola	bush	bague		
11	308297-0-00	1	bussola	bush	bague		
12	308098-0-00	1	guarnizione sinistra base	left gasket for base	garniture gauche pour base		
13	742623-2-00	1	vite	screw	vis		
14	721444-2-00	1	vite	screw	vis		
15	308138-0-02	1	carter paraolio	oil retainer cover	carter protection huile		
16	308074-0-00	1	bussola	bush	bague		
17	308031-0-00	1	bussola	bush	bague		
18	303501-0-10	1	tappo per foro tendifilo	plug	bouchon		
19	308852-0-00	1	bussola	bush	bague		
20	308232-0-00	1	bussola	bush	bague		
21	729032-2-00	1	vite	screw	vis		
22	308086-0-00	1	bussola	bush	bague		
23	308009-0-00	1	bussola	bush	bague		
24	308298-0-00	1	bussola	bush	bague		
25	302356-0-10	1	tappo	plug	bouchon		
26	308853-0-00	2	bussola	bush	bague		

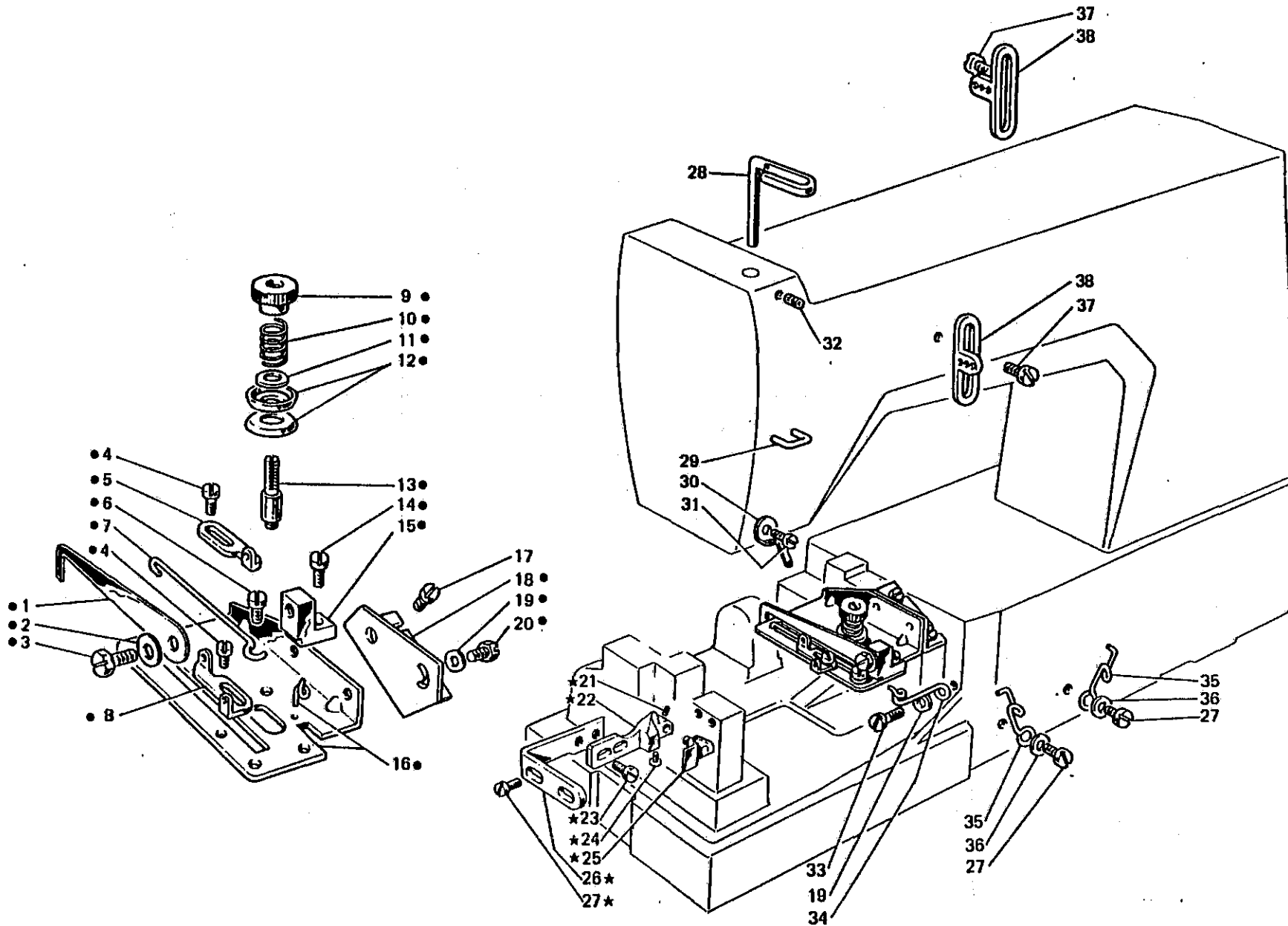

Fig. N. Abb. N.	Part. N. Bestell N. Pieza N.	Ct. Quant.	DESCRIZIONE	DESCRIPTION	DESCRIPTION	BENENNUNG	DESCRIPCION
★	307395-4-01	1	salva ago compl.	rear needle guard assembly	protège-aiguille compl.		
●	308938-4-00	1	gruppo tensione crochet inf.	tension ass. for lower looper	groupe tension crochet inférieur		
1	308556-0-00	1	astina	rod	tige		
2	705201-0-00	1	rondella	washer	rondelle		
3	740220-2-00	1	vite	screw	vis		
4	741413-2-00	2	vite	screw	vis		
5	302172-0-10	1	passafilo	thread guide	passé-fil		
6	741612-0-00	1	vite	screw	vis		
7	308558-0-00	1	traversino	tie-rod	traverse		
8	304905-0-10	1	passafilo	thread guide	passé-fil		
9	302204-0-10	1	pomolo	knob	pommeau		
10	300310-0-10	1	molla	spring	ressort		
11	704218-2-00	1	rondella	washer	rondelle		
12	200324-0-10	2	disco tensione	tension disc	disque tension		
13	300391-0-10	1	perno a vite	thread pin	pivot à vis		
14	741642-2-00	1	vite	screw	vis		
15	302168-2-10	1	supporto	support	support		
16	308553-2-00	1	piastra	plate	plaque		
17	721444-2-00	2	vite	screw	vis		
18	308551-0-00	1	squadretta	bracket	équerre		
19	704302-4-00	3	rondella	washer	rondelle		
20	740210-2-00	2	vite	screw	vis		
21	745800-2-00	1	vite	screw	vis		
22	307396-0-10	1	corpo salva ago	rear needle guard body	corps protège-aiguille		
23	741937-0-00	2	vite	screw	vis		
24	201236-0-10	1	vite	screw	vis		
25	307394-2-10	1	piastrina con perno	plate with pin	plaque avec pivot		
26	307136-0-00	1	attacco	coupling	raccord		
27	300483-0-10	4	vite	screw	vis		
28	302136-0-11	1	passafilo	thread guide	passé-fil		
29	308137-0-00	1	cavallotto	coupling	cavalier		
30	308890-0-00	1	passafilo	thread guide	passé-fil		
31	724420-2-00	1	vite	screw	vis		
32	729011-2-00	1	vite	screw	vis		
33	741682-0-00	1	vite	screw	vis		
34	302149-0-11	1	passafilo	thread guide	passé-fil		
35	311098-0-00	2	passafilo	thread guide	passé-fil		
36	704210-4-00	2	rondella	washer	rondelle		
37	303045-0-10	3	vite	screw	vis		
38	308203-0-01	3	guidafilo	thread guide	guide-fil		

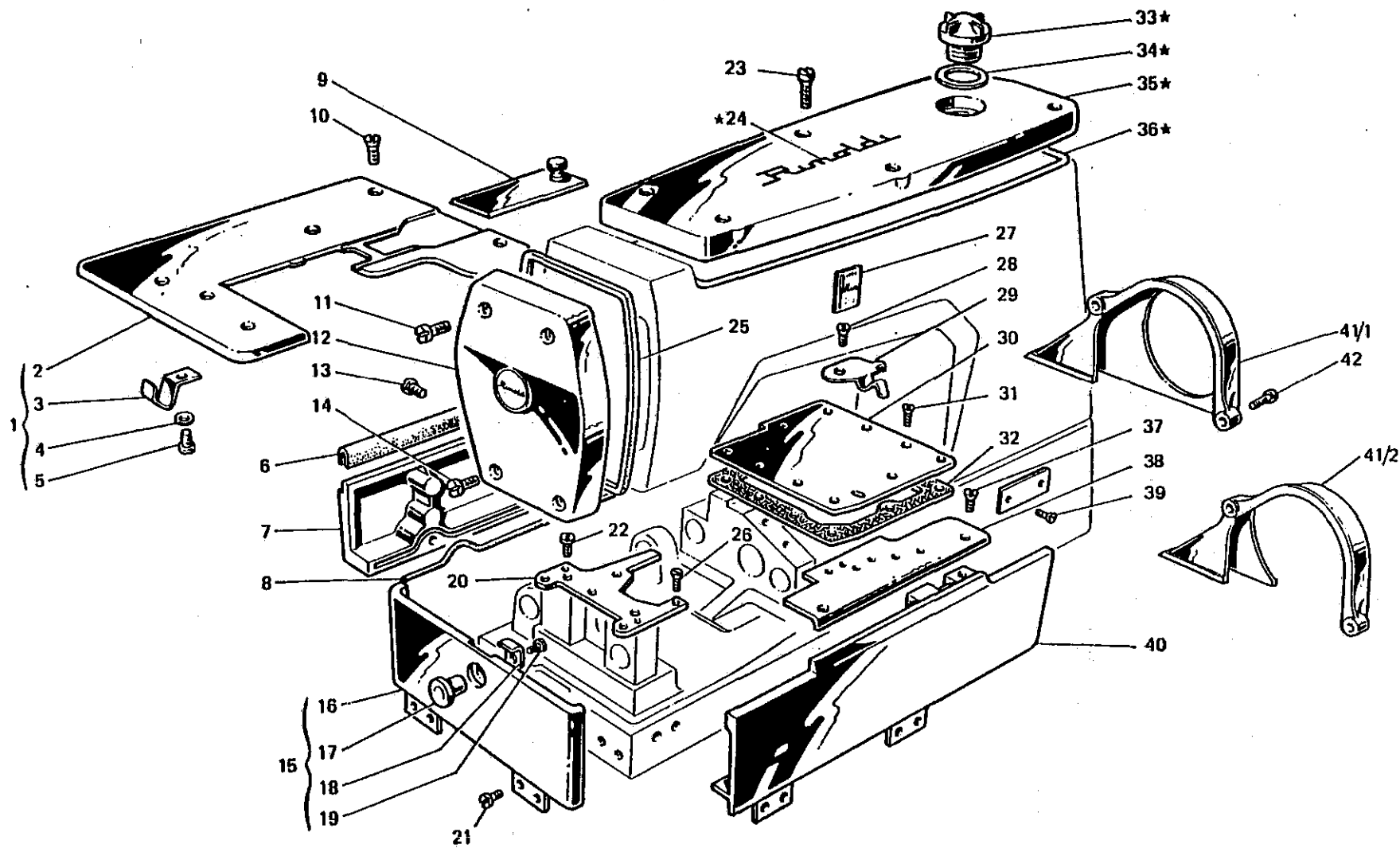

Fig. N. Abb. N.	Part. N. Bestell N. Pieza N.	Qt. Quant.	DESCRIZIONE	DESCRIPTION	DESCRIPTION	BENENNUNG	DESCRIPCION
★	308103-4-00	1	coperchio sup. completo	upper cover assembly	couvercle sup. compl.		
1	309059-4-00	1	piano di lavoro completo	working plate assembly	plan de travail complet		
2	309042-2-00	1	piano di lavoro	working plate	plan de travail		
3	309351-0-00	1	molla	spring	ressort		
4	704306-0-01	1	rondella	washer	rondelle		
5	721424-0-00	1	vite	screw	vis		
6	309088-0-00	1	guarnizione	gasket	garniture		
7	309086-0-01	1	carter posteriore	rear cover	carter arrière		
8	309084-0-00	1	guarnizione	gasket	garniture		
9	309302-2-00	1	coperchio scorrevole	sliding cover	couvercle coulissant		
10	744636-2-00	5	vite	screw	vis		
11	302354-0-10	2	vite superiore	upper screw	vis supérieure		
12	308101-2-00	1	coperchio laterale	side cover	couvercle latéral		
13	741088-2-00	3	vite per carter posteriore	screw for rear cover	vis pour carter arrière		
14	302353-0-10	2	vite inferiore	lower screw	vis inférieure		
15	309139-4-00	1	carter laterale completo	side cover assembly	carter latéral complet		
16	309126-3-00	1	carter laterale	side cover	carter latéral		
17	309372-0-00	1	perno	pin	pivot		
18	309371-0-00	1	chiavistello	key	clé		
19	741658-2-00	1	vite	screw	vis		
20	308783-2-00	1	piastra porta placca	plate	plaque		
21	300483-0-10	8	vite per cerniera	screw for hinge	vis pour charnière		
22	302355-0-10	2	vite per piastra	screw for plate	vis pour plaque		
23	742282-2-00	6	vite per coperchio	screw for cover	vis pour couvercle		
24	300006-0-11	2	decalcomania	decalcomania	décalcomanie		
25	308128-0-00	1	guarnizione coperchio	cover gasket	garniture couvercle		
26	744730-0-00	2	vite per placca ago	screw for needle plate	vis pour plaque aiguille		
27	788020-0-01	1	decalcomania sistema aghi	needle decalcomania	décalcomanie syst. aiguille		
28	721474-2-00	1	vite	screw	vis		
29	309360-0-00	1	molla chiusura carter	spring	ressort		
30	309324-2-00	1	piastra superiore	upper plate	plaque supérieure		
31	724442-2-00	9	vite per piastra	screw for plate	vis pour plaque		
32	309323-0-00	1	guarnizione	gasket	garniture		
33	202239-0-10	1	cupolina	cup	coupole		
34	705970-0-00	1	guarnizione per cupolina	gasket	garniture		
35	308102-0-10	1	coperchio superiore	upper cover	couvercle supérieur		
36	308129-0-00	1	guarnizione per coperchio	gasket for cover	garniture pour couvercle		
37	744656-2-00	2	vite	screw	vis		
38	309227-0-00	1	piastra piano di lavoro	working plate	plaque plan de travail		
39	202165-0-10	2	vite per targhetta	screw for plate	vis pour plaquette		
40	309177-3-00	1	carter anteriore completo	front cover assembly	carter avant complet		
41/1	308462-0-00	1	copricinghia per volante Ø 85	belt cover for handwheel Ø 85	couvre-courroie pour volant Ø 85		
41/2	308461-0-00	1	copricinghia per volante Ø 125	belt cover for handwheel Ø 125	couvre-courroie pour volant Ø 125		
42	721475-2-00	2	vite	screw	vis		

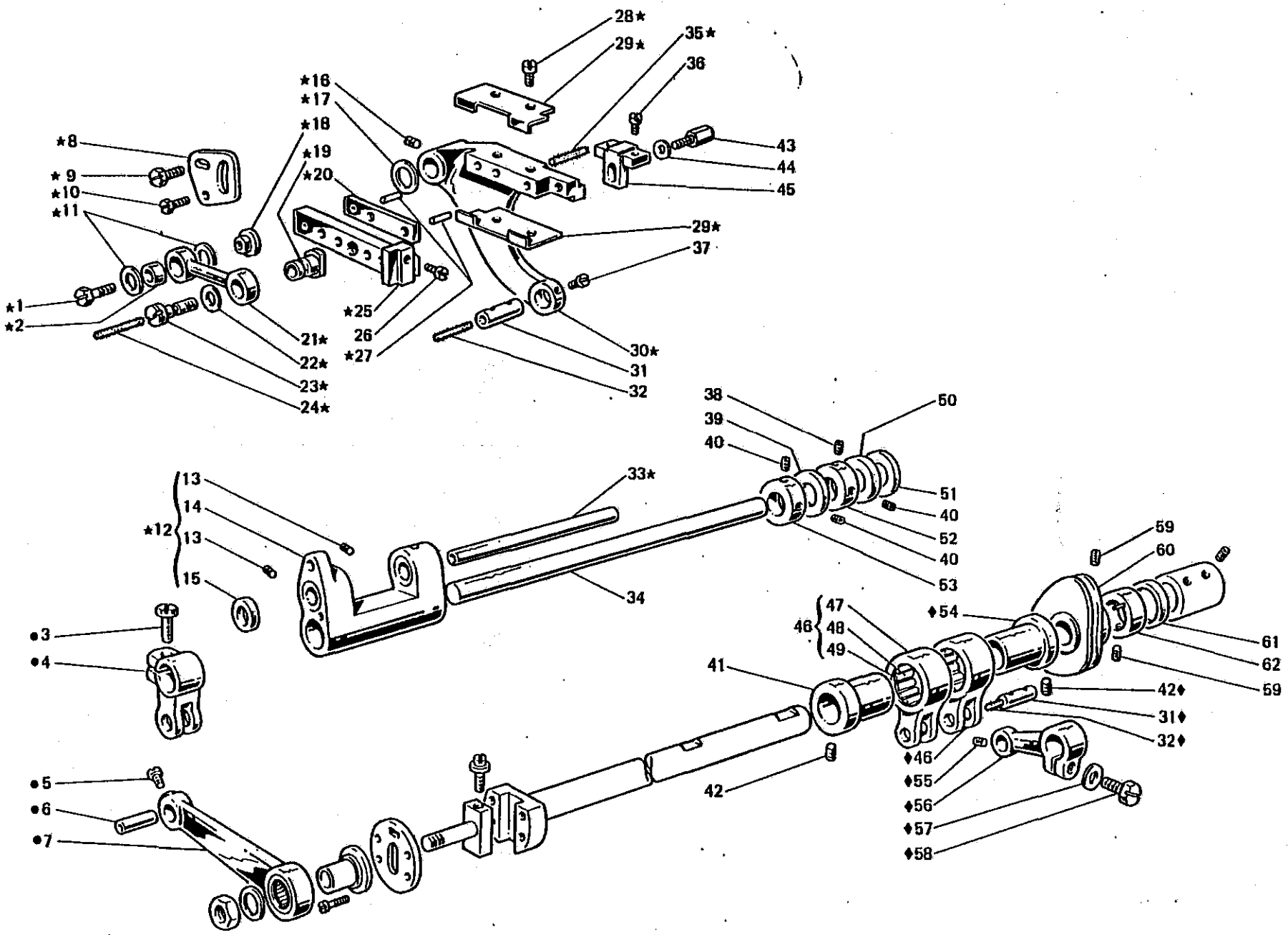

Fig. N. Abb. N.	Part. N. Bestell N. Pieça N. Pieza N.	Qt. Arzahl	DESCRIZIONE	DESCRIPTION	DESCRIPTION	BENENNUNG	DESCRIPCION
-	308346-5-00	1	gruppo porta griffa compl. (con ★-31-32-37-41-42-46)	feed dog holder assembly (with ★-31-32-37-41-42-46)	groupe porte-griffe (avec ★-31-32-37-41-42-46)		
★	308192-4-00	1	gruppo porta griffa	feed dog holder assembly	groupe porte-griffe		
●	308286-4-00	1	gruppo leva	lever assembly	groupe levier		
◆	308340-4-00	1	gruppo comando crochet	looper control assembly	groupe commande crochet		
1	740475-2-00	1	vite	screw	vis		
2	300228-0-10	1	bussola	bush	bage		
3	202486-0-10	1	vite	screw	vis		
4	301519-2-11	1	attacco	clamp	raccord		
5	742813-0-00	1	vite	screw	vis		
6	308285-0-00	1	perno	pin	pivot		
7	308284-2-00	1	leva comando porta griffa	lever	levier		
8	308194-0-00	1	settore	sector	secteur		
9	740257-0-00	1	vite	screw	vis		
10	740243-0-00	1	vite	screw	vis		
11	704805-0-00	2	rondella	washer	rondelle		
12	308191-4-00	1	supporto oscillante completo	support assembly	support coulissant complet		
13	729013-2-00	2	vite	screw	vis		
14	308193-2-00	1	supporto con viti	support with screws	support avec vis		
15	308190-0-00	2	anello di tenuta	retainer ring	bage d'étanchéité		
16	745815-2-00	1	vite	screw	vis		
17	309560-0-00	2	rondella	washer	rondelle		
18	300362-0-11	1	cursore	slider	curseur		
19	308196-0-00	1	bussola	bush	bage		
20	300361-0-10	1	plastrina	plate	plaque		
21	308275-2-00	1	biella	con-rod	bielle		
22	705008-0-00	1	rondella	washer	rondelle		
23	308276-0-00	1	vite	screw	vis		
24	778412-0-00	1	stoppino	wick	mèche		
25	300231-0-10	1	slitta porta griffa	feed dog slide	glissière		
26	721444-2-00	1	vite fissa griffa	screw	vis		
27	706434-0-00	2	spina	pin	goupille		
28	741928-0-00	4	vite	screw	vis		
29	300371-0-10	2	squadretta	bracket	équerre		
30	302028-0-11	1	braccio porta griffa	feed dog arm	bras porte-griffe		
31	300209-0-10	2	perno	pin	pivot		
32	778238-0-00	2	stoppino	wick	mèche		
33	308195-0-00	1	perno	pin	pivot		
34	308289-2-00	1	perno per supporto oscillante	pin	pivot		
35	778415-0-00	1	stoppino	wick	mèche		
36	741646-2-00	2	vite fissa griffa	screw	vis		
37	742811-0-00	1	vite	screw	vis		
38	728232-0-00	1	vite	screw	vis		
39	704846-0-00	1	rondella	washer	rondelle		
40	745136-2-00	3	vite	screw	vis		
41	308030-2-00	1	eccentrico con viti fig. 42	eccentric with screw fig. 42	excentrique avec vis fig. 42		
42	727834-2-00	4	vite	screw	vis		
43	302152-0-10	1	vite	screw	vis		

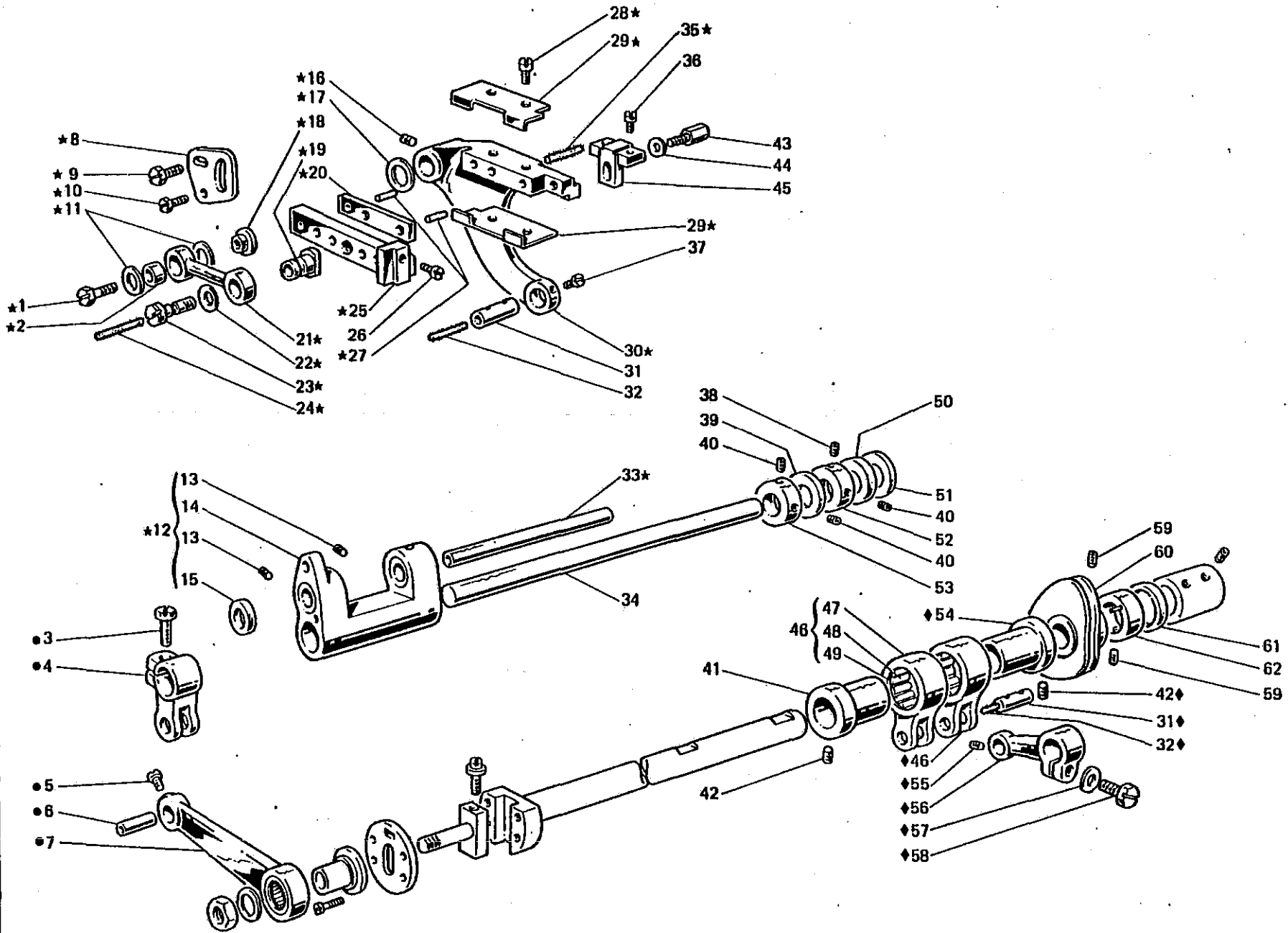

Fig. N. Abb. N.	Part. N. Bestell N. Pieza N.	Qt. Anzahl	DESCRIZIONE	DESCRIPTION	DESCRIPTION	BENENNUNG	DESCRIPCION
44	704406-0-00	1	rondella	washer	rondelle		
45	300364-0-10	1	squadrette	bracket	équerre		
46	301459-4-10	2	giunto completo per eccentrico	joint assembly for eccentric	Joint compl. pour excentrique		
47	301458-0-10	2	giunto	joint	Joint		
48	301579-0-10	2	gabbia a rullini	roller cage	cage à aiguilles		
49	201143-0-10	4	anello di tenuta	circlip	circlip		
50	308287-0-00	1	anello di tenuta	retainer ring	bague d'étanchéité		
51	704347-0-00	1	rondella	washer	rondelle		
52	309839-2-00	1	anello di registro	adjustment ring	bague de réglage		
53	309838-2-00	1	anello di registro	adjustment ring	bague de réglage		
54	308029-2-00	1	eccentrico con viti fig. 42	eccentric with screw fig. 42	excentrique avec vis fig. 42		
55	729011-2-00	1	vite	screw	vis		
56	303459-2-11	1	braccio	arm	bras		
57	704218-2-00	1	rondella	washer	rondelle		
58	300377-0-10	1	vite	screw	vis		
59	727215-0-00	3	vite	screw	vis		
60	308971-3-00	1	tendifilo a camma con viti	cam thread take-up with screws	tendeur du fil à came avec vis		
61	308119-0-00	1	anello di tenuta	retainer ring	bague d'étanchéité		
62	308967-2-00	1	anello limitatore	limiter ring	bague		

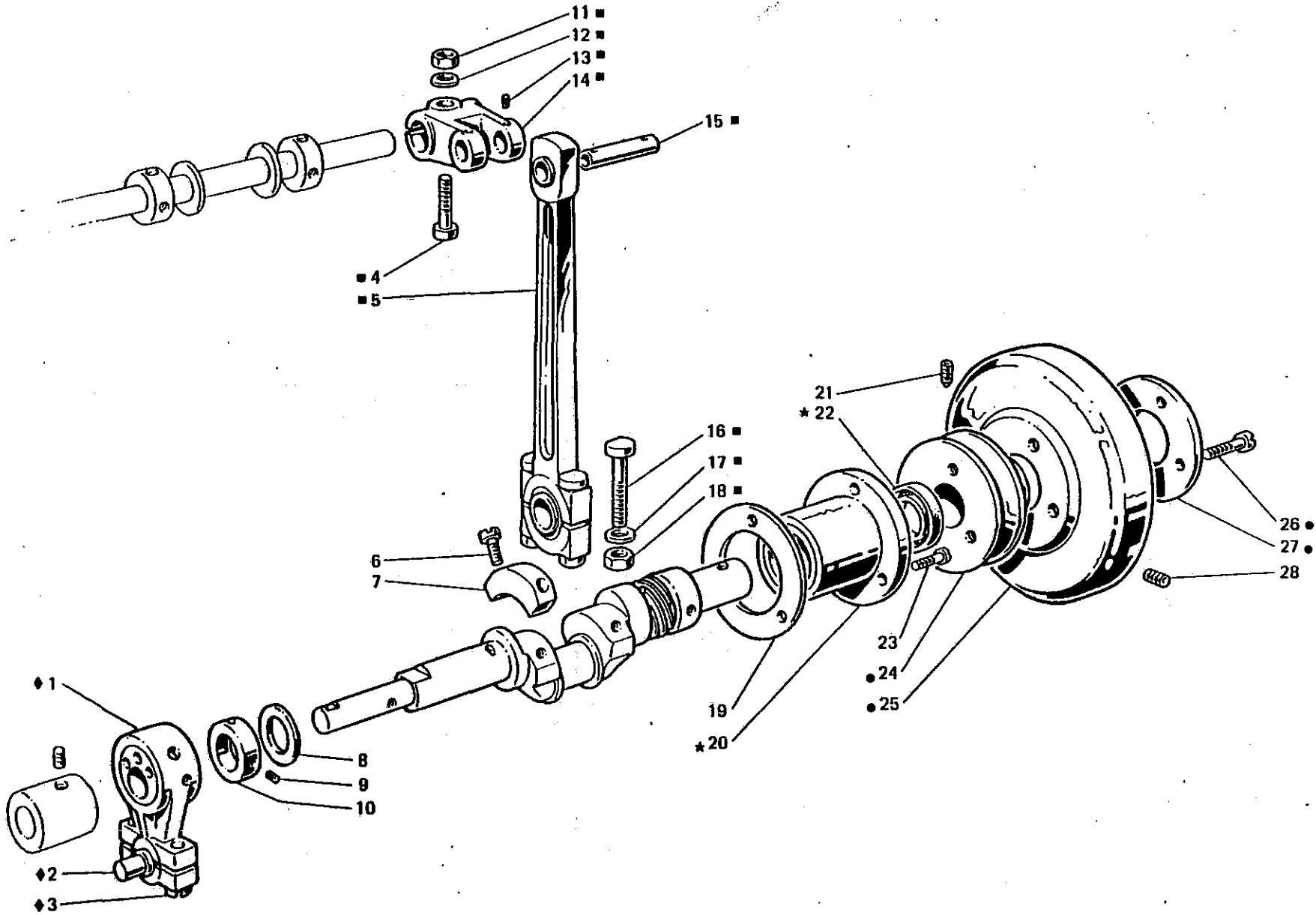

Fig. N. Abb. N.	Part. N. Bestell N. Plece N. Pieza N.	Qt. Arzani	DESCRIZIONE	DESCRIPTION	DESCRIPTION	BENENNUNG	DESCRIPCION
★	308013-4-00	1	bussola destra completa	right bush assembly	bague droite complète		
●	308407-4-00	1	volantino completo	pulley assembly	volant complet		
■	308178-4-00	1	gruppo biella principale	main con-rod assembly	groupe bielle principale		
◆	310350-4-00	1	biella con eccentrico e viti compl.	con-rod and screw assembly	bielle avec excentrique et vis compl.		
1	308253-3-00	1	biella con eccentrico e viti	con-rod with cam and screw	bielle avec excentrique et vis		
2	308310-0-00	1	perno a sfera	ball joint	pivot à sphère		
3	308802-0-00	2	vite per biella	screw for con-rod	vis pour bielle		
4	308035-0-00	1	vite	screw	vis		
5	308174-3-00	1	biella principale completa	main con-rod assembly	bielle principale complète		
6	741056-0-00	4	vite	screw	vis		
7	302272-0-10	2	settore	sector	secteur		
8	704869-0-00	1	rondella	washer	rondelle		
9	745815-2-00	2	vite	screw	vis		
10	308084-2-00	1	anello di registro con viti	adjustment ring with screws	bague de réglage avec vis		
11	746408-2-00	1	dado	nut	écrou		
12	705013-0-00	1	rondella	washer	rondelle		
13	745812-2-00	2	vite	screw	vis		
14	308159-2-01	1	manovella	crank	manivelle		
15	308166-0-00	1	perno	pin	pivot		
16	308161-0-00	2	vite	screw	vis		
17	308149-0-01	2	rondella	washer	rondelle		
18	308162-0-00	2	dado	nut	écrou		
19	308127-0-00	1	guarnizione	gasket	garniture		
20	308012-2-00	1	bussola	bush	bague		
21	730054-2-00	1	vite per volantino	screw for pulley	vis pour volant		
22	700596-0-00	1	anello di tenuta	retainer ring	bague d'étanchéité		
23	742222-2-00	3	vite	screw	vis		
24	308197-0-00	1	puleggia	pulley	poulie		
25	308410-0-00	1	colonna	crown	couronne		
26	741984-2-00	3	vite	screw	vis		
27	308199-0-00	1	flangia	flange	flaque		
28	729044-2-00	1	vite	screw	vis		

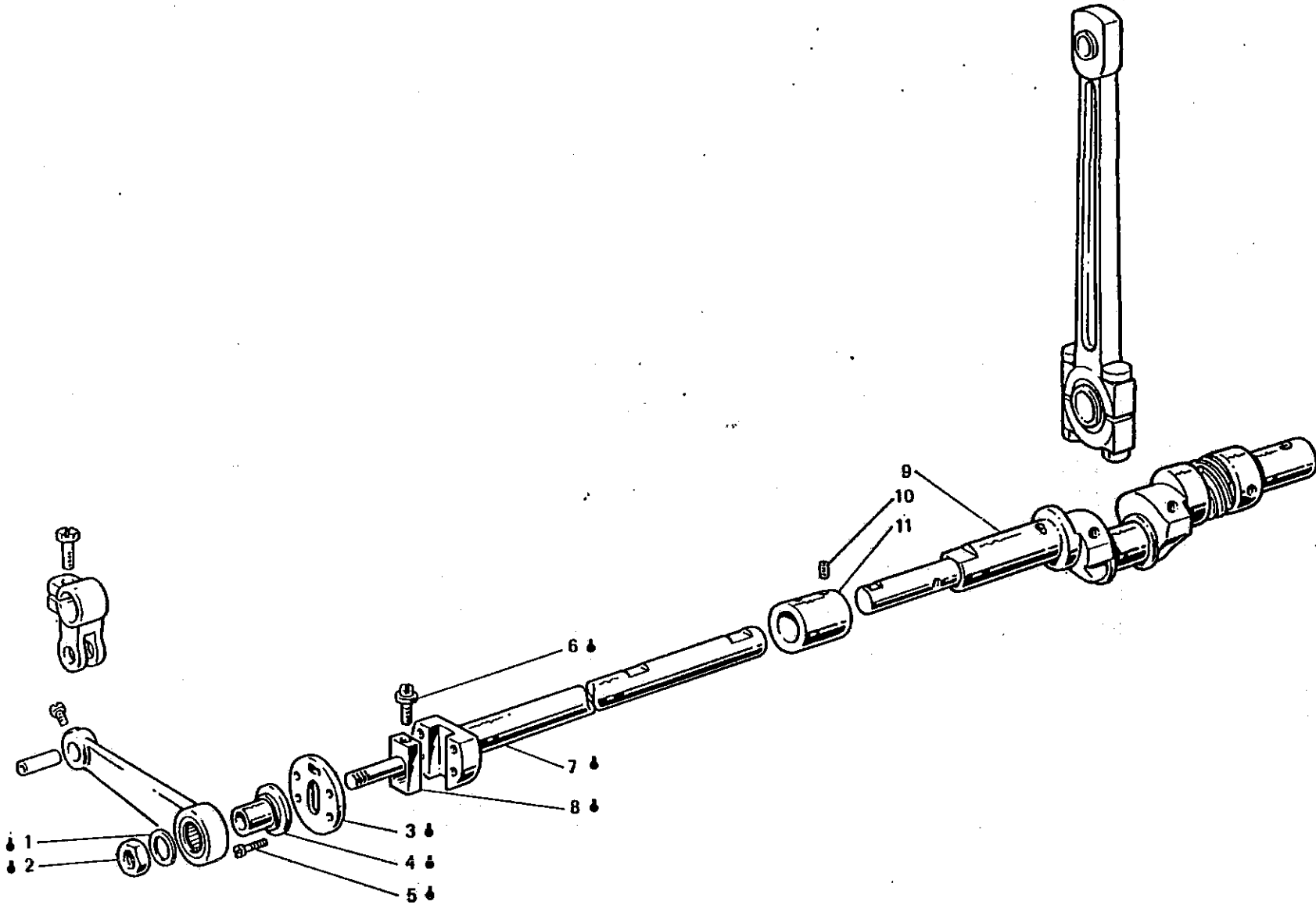

Fig. N. Abb. N.		Part. N. Bestell N. Pieze N. Pieza N.	Qt. Anzahl	DESCRIZIONE	DESCRIPTION	DESCRIPTION	BENENNUNG	DESCRIPCION
—		309704-4-00	1	albero inferiore completo	lower shaft assembly	arbre inférieur complet		
•		308358-4-00	1	semialbero inferiore completo	lower half-shaft assembly	semi-arbre inférieur complet		
1		704814-0-00	1	rondella	washer	rondelle		
2		746612-2-00	1	dado	nut	écrou		
3		308280-0-00	1	piastra disco	disc plate	plaque		
4		303458-0-12	1	bussola	bush	bague		
5		724441-0-00	4	vite	screw	vis		
6		308281-0-00	1	vite di registro	adjustment screw	vis de réglage		
7		308381-2-00	1	semialbero inf. sinistro	left lower half-shaft	semi-arbre inférieur gauche		
8		308278-0-00	1	perno	pin	pivot		
9		308714-3-00	1	semialbero inferiore destro	right lower half-shaft	semi-arbre inférieur droite		
10		745827-2-00	4	vite per manicotta	screw	vis		
11		308015-0-00	1	manicotto	coupling	manchon		

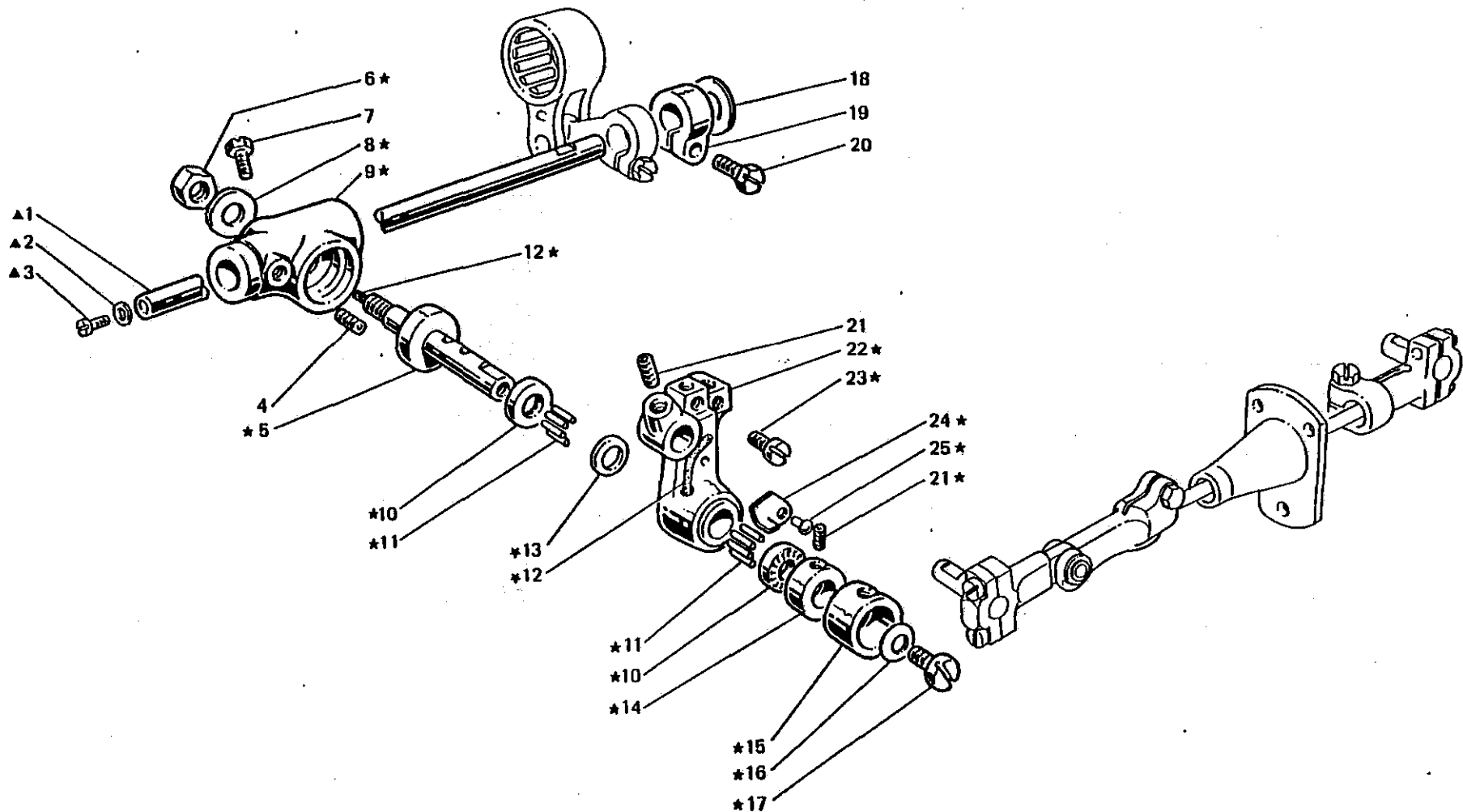

Fig. N. Abb. N.	Part. N. Bestell N. Piece N. Pieza N.	Qt. Anzahl.	DESCRIZIONE	DESCRIPTION	DESCRIPTION	BENENNUNG	DESCRIPCION
*	308263-4-00	1	gruppo porta crochet	looper holder assembly	groupe porte-crochet		
A	308292-4-00	1	contralbero crochet inf. compl.	lower looper countershaft ass.	axe crochet inf. compl.		
1	308291-0-01	1	perno per supporto	pin for support	pivot pour support		
2	705734-0-00	1	guarnizione	gasket	garniture		
3	742214-2-00	1	vite	screw	vis		
4	730033-2-00	1	vite	screw	vis		
5	308271-0-00	1	perno	pin	pivot		
6	202474-0-10	1	dado	nut	écrou		
7	740226-0-00	1	vite per supporto	screw for support	vis pour support		
8	704226-2-00	1	rondella	washer	rondelle		
9	308140-0-00	1	supporto del porta crochet	support for looper holder	support du porte crochet		
10	303539-0-00	2	reggisplinta	thrust bearing	butée		
11	302276-0-10	40	rullino	roller	rouleau		
12	778827-0-00	2	stoppino	wick	mèche		
13	703810-0-00	1	distanziale	spacer	entretoise		
14	302052-2-21	1	ghiera con viti	ring with screws	collier avec vis		
15	303538-0-00	1	cappello di protezione	protection cap	capouchon de protection		
16	702403-0-00	1	molla a tazza	cup spring	ressort à tasse		
17	742423-0-00	1	vite	screw	vis		
18	704846-0-00	1	rondella	washer	rondelle		
19	300469-2-11	1	fascetta	clamp	bride		
20	300482-0-10	1	vite	screw	vis		
21	745815-2-00	3	vite per leva	screw	vis		
22	308268-2-00	1	porta crochet inferiore	lower looper holder	porte crochet inférieur		
23	303503-0-10	1	vite fissa crochet	looper fixing screw	vis blocage crochet		
24	308272-0-00	1	piastrina	sheet	plaquette		
25	308273-0-00	1	rivetto	rivet	rivet		

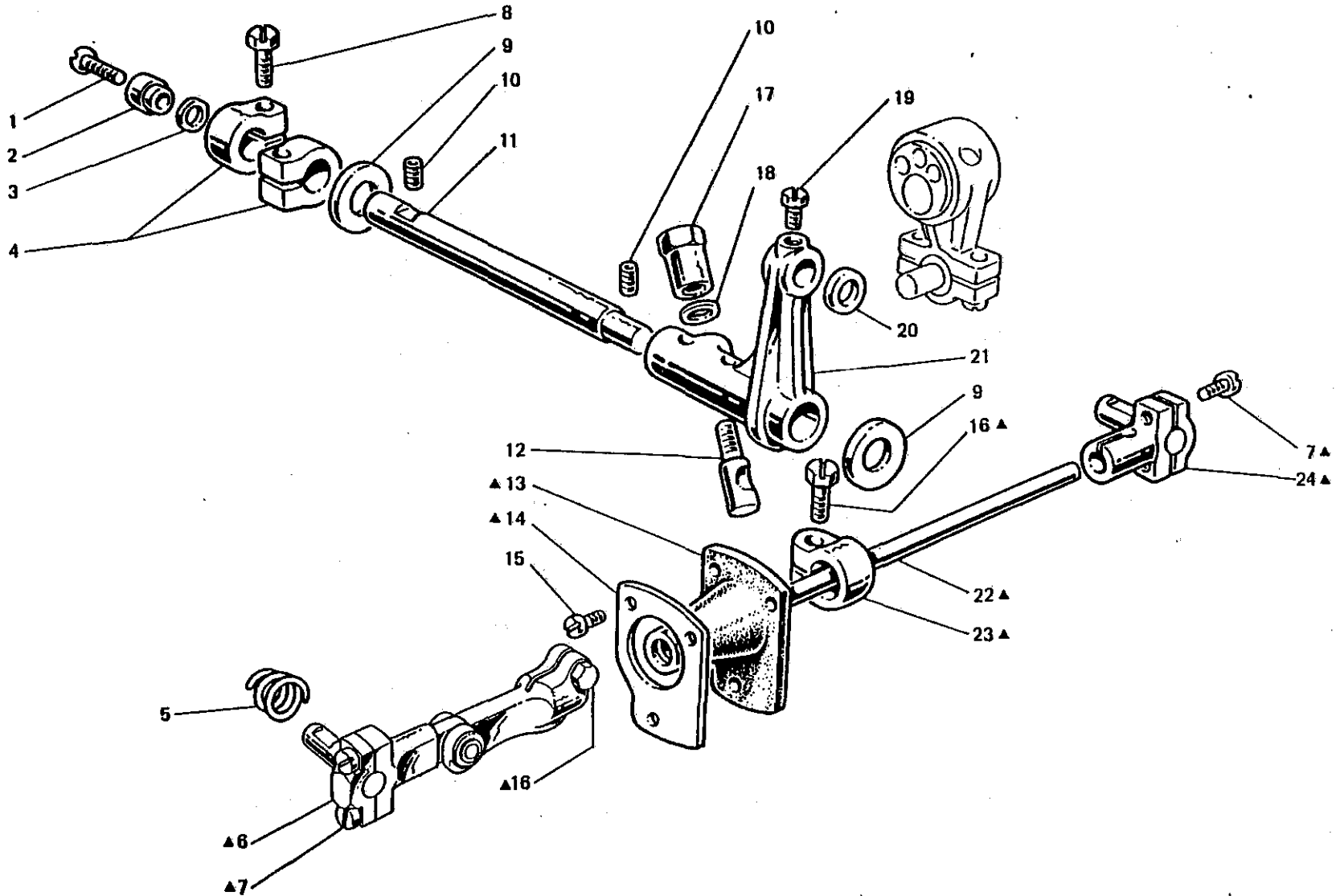

Fig. N. Abb. N.	Part. N. Bestell N. Place N. Pieze N.	Qt. AVEN	DESCRIZIONE	DESCRIPTION	DESCRIPTION	BENENNUNG	DESCRIPCION
A	308459-4-00	1	gruppo comando crochet inf.	lower looper control assembly	groupe com. crochet inférieur		
1	744676-2-00	1	vite	screw	vis		
2	308047-0-00	1	scodellino	cup	cuvette		
3	701009-0-00	1	anello di tenuta	oil ring	bague d'étanchéité		
4	308046-2-01	2	fascetta	clamp	bride		
5	302289-0-10	1	molla	spring	ressort		
6	308458-3-00	1	testa di biella con viti	con-rod big end with screws	tête de bielle avec vis		
7	744040-2-00	4	vite	screw	vis		
8	300482-0-10	2	vite	screw	vis		
9	704849-0-00	2	rondella	washer	rondelle		
10	729434-2-00	2	vite fissa perno	screw	vis		
11	308044-0-00	1	perno per supporto	pin	pivot		
12	300352-0-10	1	spina filettata	pin	pivot à vis		
13	308330-3-00	1	manicotto para olio	oil protection	manchon pare huile		
14	308327-0-00	1	mascherina per manicotto	flange	flasque		
15	741675-2-00	2	vite	screw	vis		
16	305194-0-00	2	vite	screw	vis		
17	300351-0-11	1	dado	nut	écrou		
18	704309-4-00	1	rondella	washer	rondelle		
19	740632-2-00	1	vite	screw	vis		
20	705834-0-00	1	rondella in fibra	washer	rondelle		
21	308045-0-01	1	supporto oscillante	support	support coulissant		
22	308334-0-00	1	tirante per biella	tie-rod	tirant pour bielle		
23	308326-2-01	1	fascetta per biella con vite	clamp with screw	bride avec vis		
24	308325-3-00	1	testa di biella con viti	con-rod big end with screws	tête de bielle avec vis		

308006

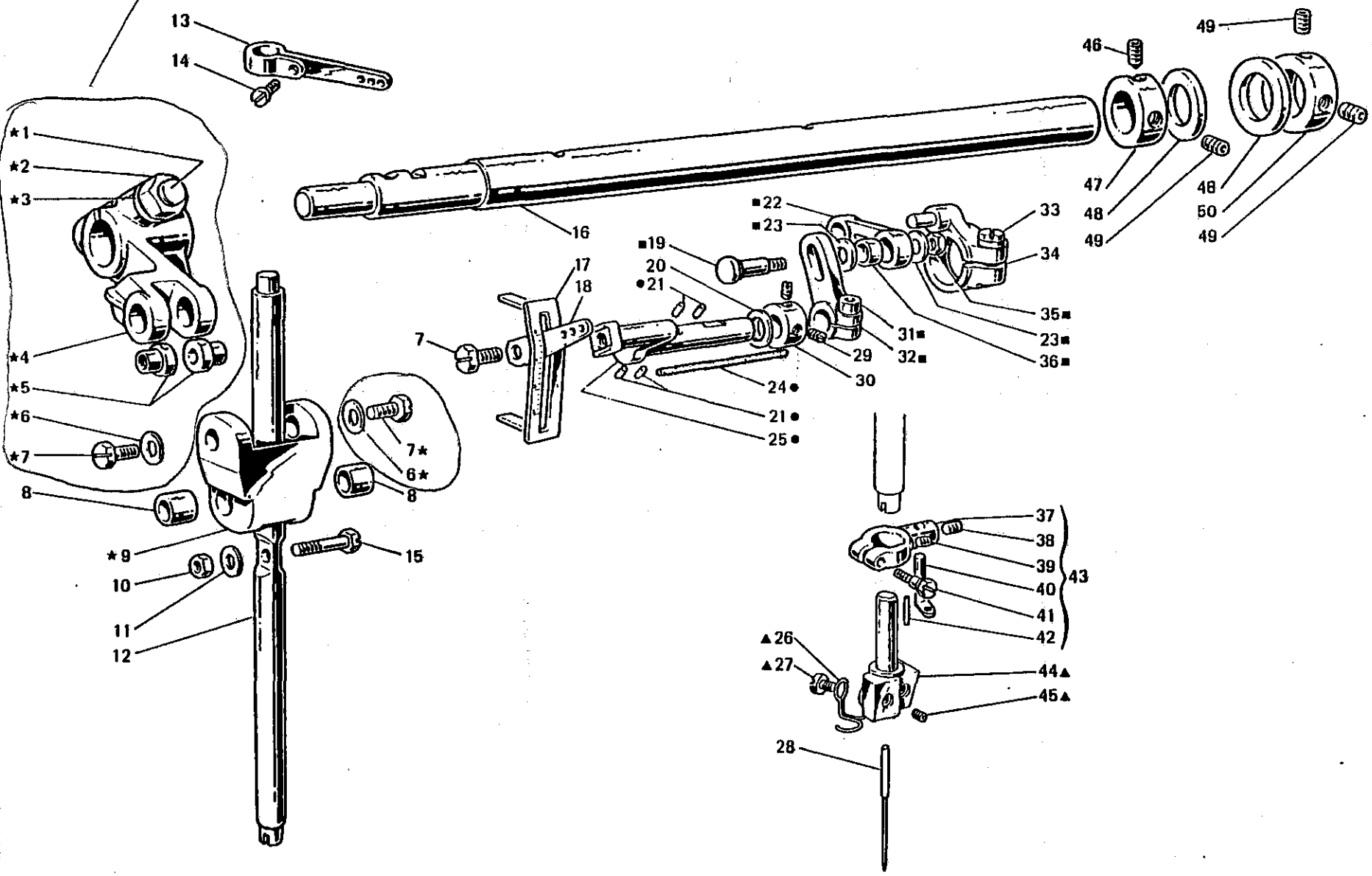

Fig. N. Abb. N.	Part. N. Bestell N. Pieza N.	Qt. Anzahl	DESCRIZIONE	DESCRIPTION	DESCRIPTION	BENENNUNG	DESCRIPCION
★	308006-4-00	1	gruppo manov. giunto barra ago	crank and joint assembly	groupe manlv.joint barre-aiguille		
▲	309851-4-00	1	morsetto porta aghi completo	needles clamp assembly	porte-aiguilles complet		
●	308238-4-00	1	braccio con stoppini	arm with wicks	bras avec mâche		
■	308244-4-00	1	gruppo settore tenditore articol.	sector assembly	groupe secteur		
†	308855-0-00	1	perno a vite	threaded pin	pivot à vis		
2	746408-2-00	1	dado	nut	écrou		
3	705013-0-00	1	rondella	washer	rondelle		
4	308036-2-00	1	manovella completa	crank assembly	groupe bras manivelle		
5	308037-0-00	2	perno superiore	upper pin	pivot supérieur		
6	704210-4-00	2	rondella	washer	rondelle		
7	308039-0-01	3	vite	screw	vis		
8	308041-0-00	2	bussola inferiore	lower bush	bague inférieure		
9	308038-0-10	1	giunto barra ago	needle bar joint	joint barre-aiguille		
10	302338-0-10	1	dado	nut	écrou		
11	703005-0-00	1	rondella	washer	rondelle		
12	308221-0-00	1	barra ago	needle bar	barre aiguille		
13	308139-2-01	1	tendifilo superiore	upper thread take-up	tendeur supérieur		
14	742311-2-00	1	vite	screw	vis		
15	308042-0-00	1	perno per barra ago	pin for needle bar	pivot pour barre-aiguille		
16	308851-2-00	1	albero superiore	upper shaft	arbre supérieur		
17	308005-0-00	1	targhetta	plate	plaque		
18	308239-0-00	1	tendifilo inferiore	lower thread guide	tendeur du fil inférieur		
19	308235-0-00	1	perno	pin	pivot		
20	704828-0-00	1	rondella	washer	rondelle		
21	778203-0-00	4	stoppino	wick	mâche		
22	206583-0-00	1	biellino	con-rod	petite bielle		
23	705208-0-00	2	rondella	washer	rondelle		
24	778544-0-00	1	stoppino	wick	mâche		
25	308233-0-00	1	braccio	arm	bras		
26	309768-0-00	1	passafilo	thread guide	passa-fil		
27	741620-2-00	1	vite	screw	vis		
28	766000-6-90	2	ago sist. Rim 63 fin. 90	needle syst. Rim 63 size 90	aiguille syst. Rim 63 Jauge 90		
29	745812-2-00	2	vite	screw	vis		
30	303899-0-10	1	anello	ring	anneau		
31	722422-2-00	1	vite	screw	vis		
32	308234-2-00	1	settore con vite	sector with screw	secteur avec vis		
33	201128-0-10	1	vite	screw	vis		
34	308236-2-00	1	braccio con vite	arm with screw	bras avec vis		
35	746008-0-00	1	dado	nut	écrou		
36	202032-0-11	1	bussolina	bush	bague		
37	303669-0-11	1	fascetta per barra ago	clamp for needle bar	bride pour barre-aiguille		
38	745800-2-00	1	vite	screw	vis		
39	745001-0-00	1	vite	screw	vis		
40	300348-0-10	1	guidafilo	thread guide	guide-fil		
41	302352-0-10	1	vite	screw	vis		
42	302292-0-10	1	spinetta	pin	goupille		
43	303670-4-12	1	fascetta completa	clamp assembly	bride complète		
44	309759-2-00	1	morsetto porta aghi	needles clamp	porte-aiguilles		
45	745810-2-00	2	vite	screw	vis		

Fig. N. Abb. N.	Part. N. Bastell N. Pieze N. Pieza N.	Qt. Anzahl	DESCRIZIONE	DESCRIPTION	DESCRIPTION	BENENNUNG	DESCRIPCION
46	730033-2-00	1	vite	screw	vis		
47	309831-2-00	1	anello di registro con viti	adjustment ring with screws	bague de réglage avec vis		
48	704869-0-00	2	rondella	washer	rondelle		
49	729013-2-00	3	vite	screw	vis		
50	309830-2-00	1	anello di registro con viti	adjustment ring with screws	bague de réglage avec vis		

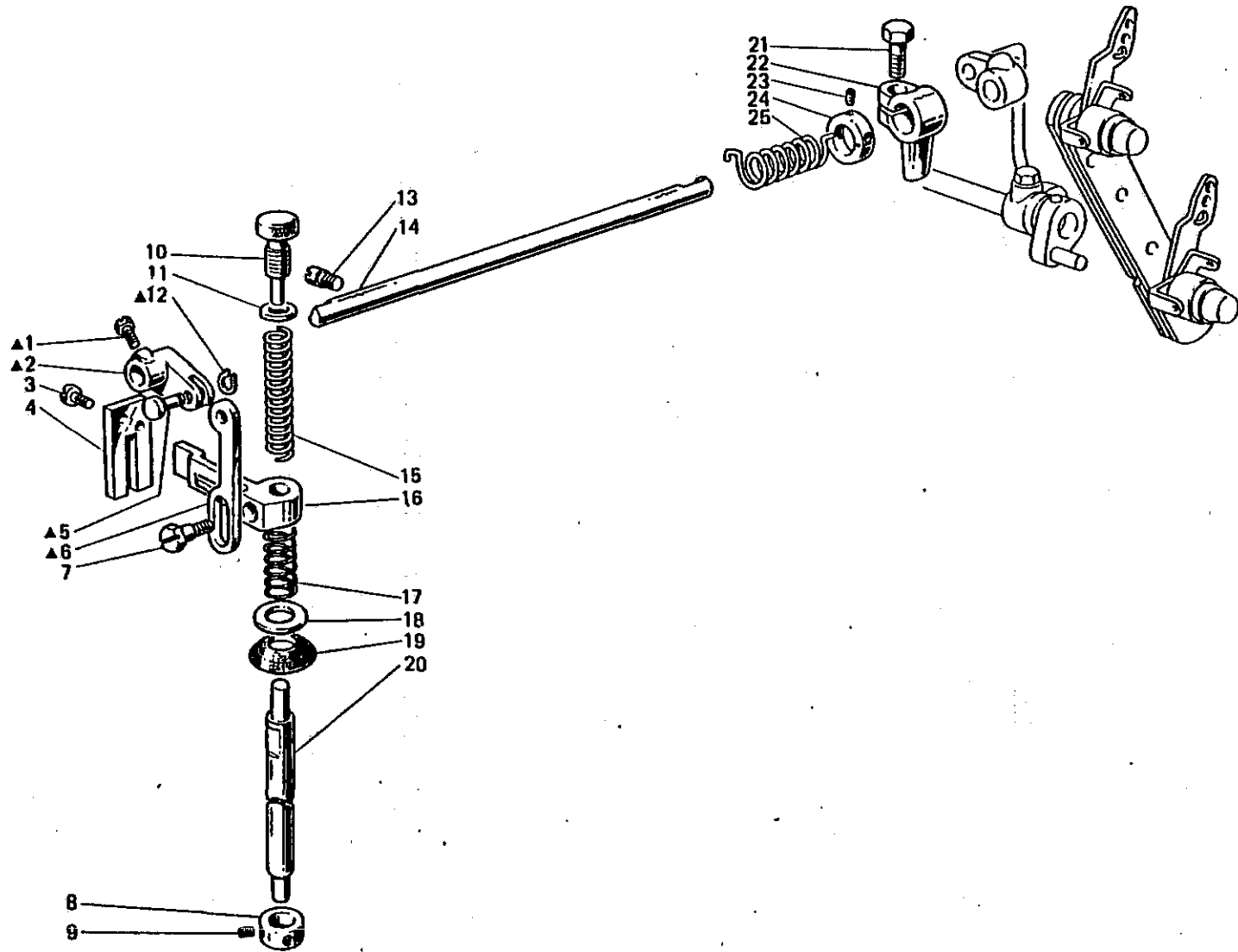

Fig. N. Abb. N.	Part. N. Bestell N. Pieza N. Pieza N.	Q.t. Quant.	DESCRIZIONE	DESCRIPTION	DESCRIPTION	BENENNUNG	DESCRIPCION
A	308060-4-00	1	gruppo manov. tirante premistoffa	presser crank assembly	groupe maniv. tirant presseur		
1	740632-2-00	1	vite	screw	vis		
2	308059-0-00	1	manovella	crank	manivelle		
3	721494-2-00	2	vite fissa piastra	plate screw	vis blocage plaque		
4	308056-0-00	1	piastra guida barra	plate	plaque		
5	308058-0-00	1	spina	pin	goupille		
6	308057-0-00	1	tirante per alza piedino	presserfoot tie-rod	tirant soulèvement pied de biche		
7	740444-2-00	1	vite fissa slitta	screw	vis blocage glissière		
8	308076-2-01	1	anello registro	adjustment ring	anneau de réglage		
9	745812-2-00	2	vite	screw	vis		
10	302060-0-11	1	pomolo di regolazione	adjustment knob	pommeau de réglage		
11	302344-0-10	1	rondella	washer	rondelle		
12	700205-0-00	1	anello elastico	spring ring	anneau ressort		
13	308007-0-00	1	perno filettato	threaded pin	pivot fileté		
14	302234-0-10	1	albero	shaft	arbre		
15	302059-0-10	1	molla premi piedino	spring	ressort pied de biche		
16	308055-2-00	1	guida a forcilla	forket guide	guide à fourchette		
17	308148-0-00	1	molla	spring	ressort		
18	703810-0-00	1	rondella	washer	rondelle		
19	308054-0-00	1	paraolio	oil retainer	pare-huile		
20	308061-0-01	1	barra porta piedino	presserfoot bar	barre porte-pied de biche		
21	202487-0-10	1	vite	screw	vis		
22	308412-2-00	1	fascetta di fermo con vite	clamp with screw	bride de fixation avec vis		
23	745827-2-00	2	vite	screw	vis		
24	304767-2-10	1	anello	ring	bague		
25	308098-0-00	1	molla di torsione	spring	ressort de torsion		

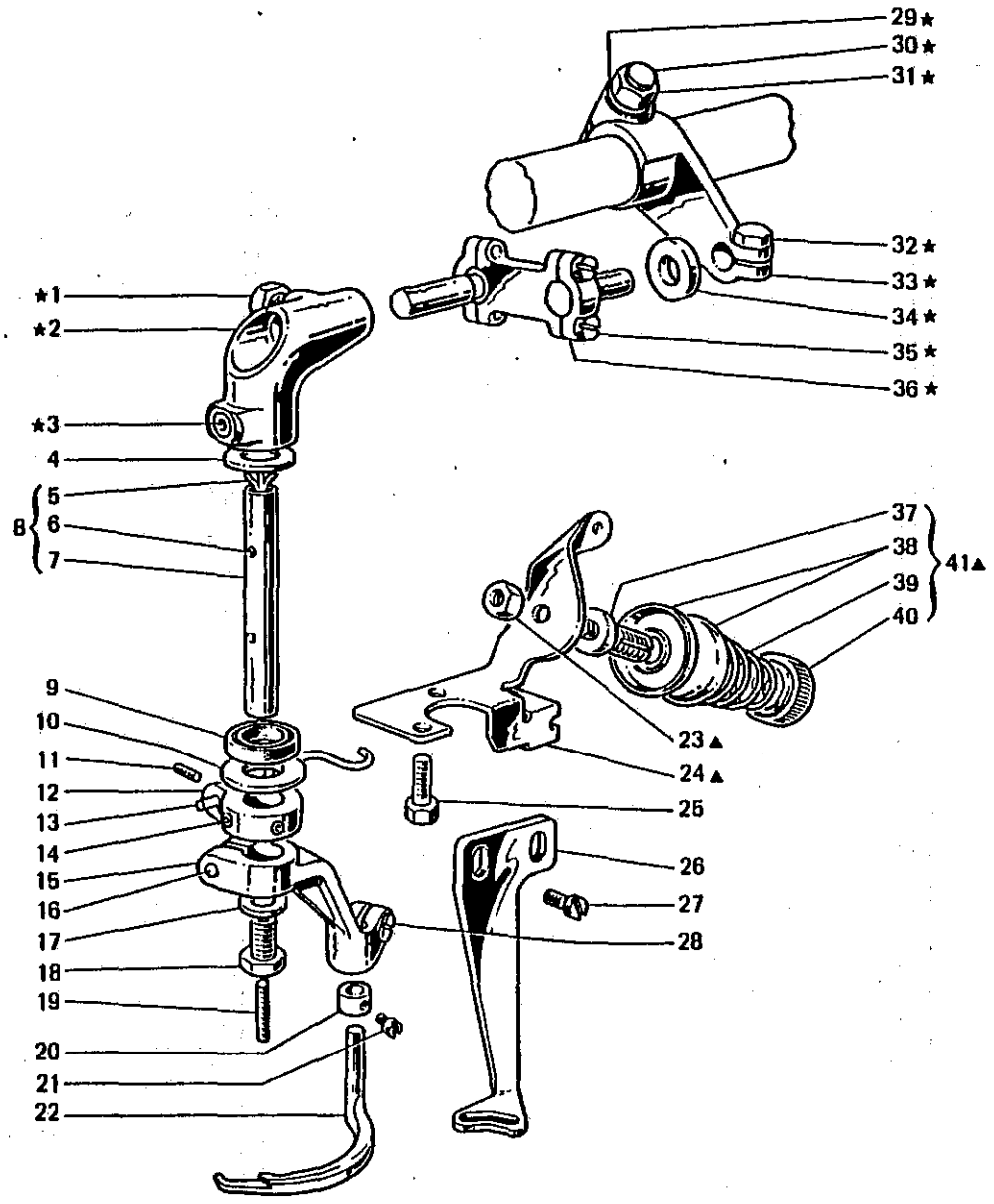

Fig. N. Abb. N.	Part. N. Piecce N. Bnstell N. Pieza N.	Cic. Arzenti	DESCRIZIONE	DESCRIPTION	DESCRIPTION	BENENNUNG	DESCRIPCION
★	308079-4-00	1	gruppo crochet copertura	top covering looper assembly	groupe crochet de couverture		
▲	308867-4-00	1	gruppo tensione copertura	tension assembly	groupe tension		
1	740226-0-00	1	vite	screw	vis		
2	308072-2-00	1	raccordo	pipe connection	raccord		
3	730033-2-00	1	vite	screw	vis		
4	704834-0-00	1	rondella	washer	rondelle		
5	778502-0-00	1	stoppino	wick	mèche		
6	778204-0-00	4	stoppino	wick	mèche		
7	308073-0-00	1	perno	pin	pivot		
8	308081-4-00	1	perno verticale	pin	pivot		
9	308075-0-00	1	anello di tenuta	retainer ring	bague d'étanchéité		
10	704835-0-00	1	rondella	washer	rondelle		
11	745800-2-00	1	vite	screw	vis		
12	308868-2-00	1	anello porta astina	ring	anneau		
13	308869-0-00	1	astina tendifilo	rod	tige		
14	745812-2-00	2	vite	screw	vis		
15	308077-2-00	1	porta crochet	looper holder	porte crochet		
16	721494-2-00	1	vite	screw	vis		
17	704309-4-00	1	rondella	washer	rondelle		
18	308078-0-00	1	vite registro	screw	vis		
19	729051-2-00	1	vite	screw	vis		
20	308082-2-00	1	anello	ring	anneau		
21	721410-0-00	1	vite	screw	vis		
22	308750-2-00	1	crochet di copertura	covering looper	crochet couverture		
23	746007-2-00	1	dado	nut	écrou		
24	308865-2-00	1	piastra con passafilo	plate with thread guide	plaque avec passe-fil		
25	740236-0-00	2	vite	screw	vis		
26	308753-0-00	1	passafilo a camma	thread guide	passe-fil		
27	741658-2-00	2	vite	screw	vis		
28	741724-0-00	1	vite	screw	vis		
29	705013-0-00	1	rondella	washer	rondelle		
30	308855-0-00	1	perno a vite	threaded pin	pivot à vis		
31	746408-2-00	1	dado	nut	écrou		
32	302347-0-10	1	vite	screw	vis		
33	308065-2-00	1	manovella albero	crank shaft	manivelle arbre		
34	308092-0-00	1	rondella	washer	rondelle		
35	308067-0-00	4	vite	screw	vis		
36	308071-3-00	1	gruppo manovella	crank assembly	groupe manivelle		
37	308862-0-00	1	perno a vite	threaded pin	pivot à vis		
38	308863-0-00	2	disco tensione	tension disc	disque tension		
39	308860-0-00	1	molla	spring	ressort		
40	308861-0-00	1	pomolo	knob	pommeau		
41	308864-4-00	1	gruppo tensione	tension assembly	groupe tension		

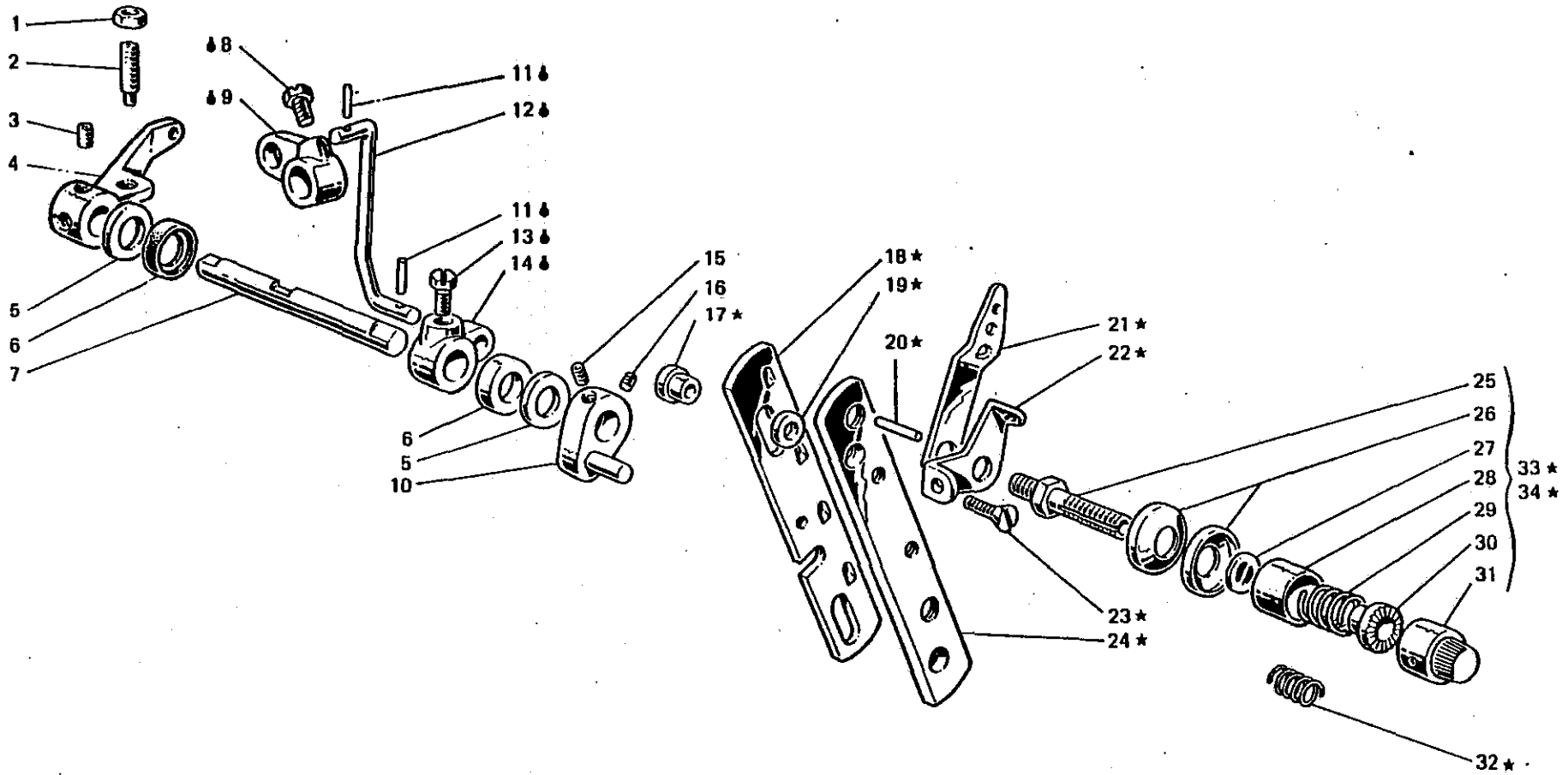

Fig. N. Abb. N.	Part. N. Piece N. Bestell N. Pieza N.	Qt. Anzahl	DESCRIZIONE	DESCRIPTION	DESCRIPTION	BENENNUNG	DESCRIPCION
★	308527-4-00	1	gruppo tensioni	tension assembly	groupe tensions		
⊕	308320-4-00	1	tirante con leva	tie-rod with lever	tirant avec levier		
1	746204-0-00	1	dado	nut	écrou		
2	729884-2-00	1	vite	screw	vis		
3	729034-2-00	2	vite per leva	screw for lever	vis pour levier		
4	308062-2-00	1	leva comando alza piedino	presserfoot control lever	levier soulév. pied de biche		
5	704240-2-00	2	rondella	washer	rondelle		
6	304763-0-10	2	anello di tenuta	retainer ring	bague d'étanchéité		
7	308996-0-01	1	albero comando alza piedino	shaft	arbre soulév. pied de biche		
8	740632-2-00	1	vite	screw	vis		
9	302232-0-10	1	leva superiore	upper lever	levier supérieur		
10	308495-2-00	1	leva sblocca tensione	lever	levier déblocage tension		
11	707241-0-00	2	spina elastica	split pin	goupille		
12	308321-0-00	1	tirante	tie-rod	tirant		
13	740636-2-00	1	vite per leva	screw	vis pour levier		
14	302238-0-10	1	leva per tirante	tie-rod lever	levier pour tirant		
15	745126-2-00	1	vite	screw	vis		
16	727834-2-00	1	vite	screw	vis		
17	308512-0-00	2	distanziale	spacer	entretoise		
18	308502-0-00	1	slitta per tensione	slide for tension	glissière tension		
19	701007-0-00	2	anello	ring	anneau		
20	308506-0-00	4	pernetto	pin	pivot		
21	308501-0-01	4	passafilo	thread guide	passe-fil		
22	308503-0-01	4	guidafilo	thread guide	guide fil		
23	744676-2-00	2	vite	screw	vis		
24	308504-0-00	1	supporto	support	support		
25	308505-0-00	4	perno a vite	threaded pin	pivot à vis		
26	300218-0-10	8	disco tensione	tension disc	disque tension		
27	308507-0-00	4	rondella	washer	rondelle		
28	202556-0-00	4	scodellino	cup	cuvette		
29	200710-0-10	2	molla	spring	ressort		
30	202229-0-10	4	bussola superiore	upper bush	bague supérieure		
31	202558-2-00	4	pomolo	knob	pommeau		
32	200714-0-10	2	molla	spring	ressort		
33	308518-4-00	2	tensione sup. con molla fig. 29	upper tension with spring fig. 29	tension sup. avec ressort fig. 29		
34	308521-4-00	2	tensione inf. con molla fig. 32	lower tension with spring fig. 32	tension inf. avec ressort fig. 32		

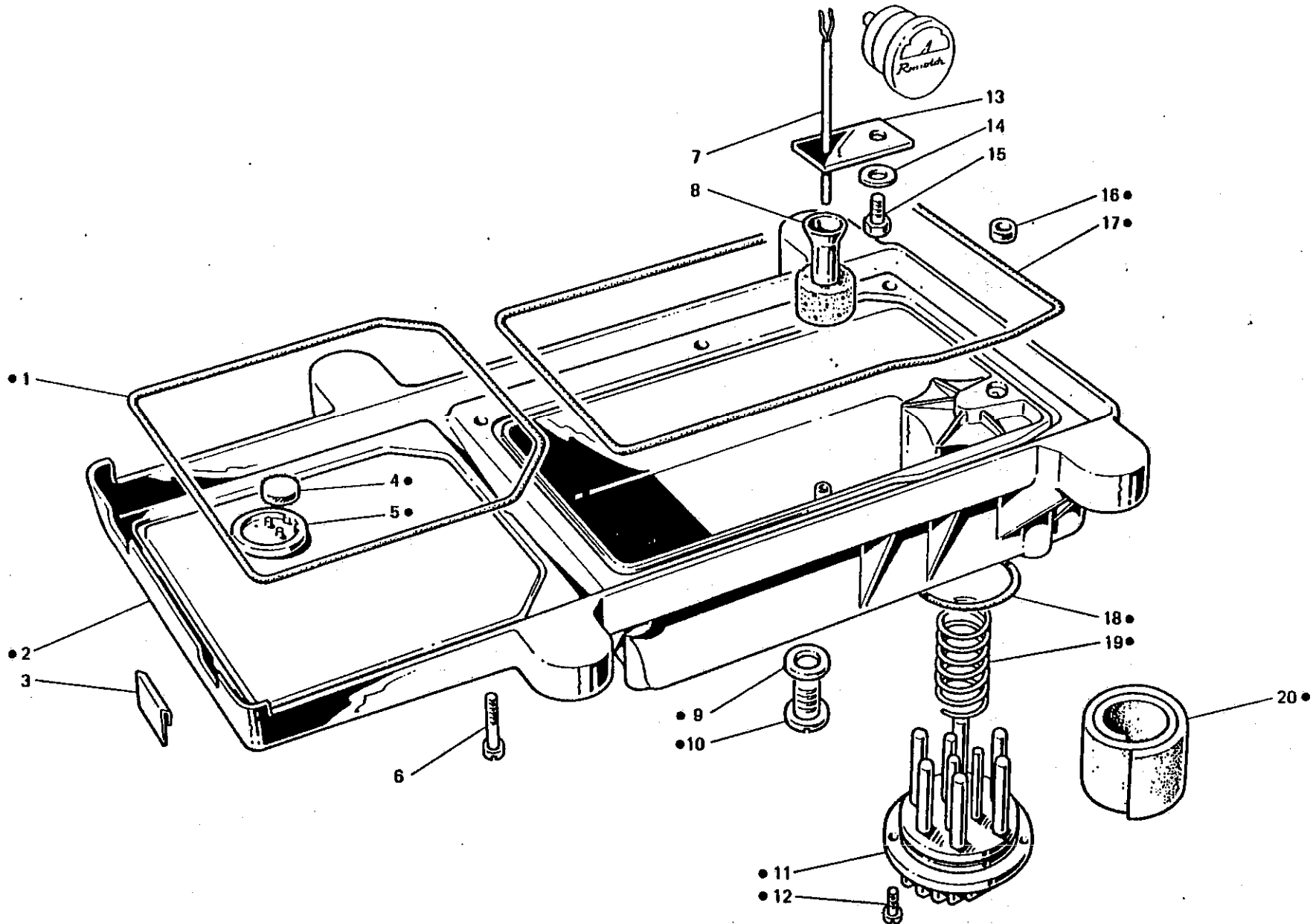

Fig. N. Abb. N.	Part. N. Bestell N. Pieza N.	Qt. Anzahl	DESCRIZIONE	DESCRIPTION	DESCRIPTION	BENENNUNG	DESCRIPCION
●	308588-4-01	1	bacinella olio completa	oil sump assembly	reservoir huile complet		
1	308125-0-00	1	guarnizione	gasket	garniture		
2	308576-2-01	1	bacinella	sump	reservoir		
3	308002-0-00	2	piastrina per bacinella	sheet for sump	plaquette pour reservoir		
4	308151-0-00	1	filtro	filter	filtre		
5	308150-0-10	1	scodellino recupero olio	cup	cuvette		
6	722453-2-00	8	vite per fiss. bacinella	sump fixing screw	vis blocage reservoir		
7	308231-2-01	1	astina livello olio	stick	jauge niveau huile		
8	308228-2-00	1	galleggiante	float	flotteur		
9	705977-0-00	1	rondella	washer	rondelle		
10	206564-0-00	1	teppo	plug	bouchon		
11	206560-0-10	1	coperchio	cover	couvercle		
12	721464-2-00	2	vite	screw	vis		
13	308226-0-01	1	guida astina	guide for stick	guide barre		
14	703003-0-00	1	rondella elastica	spring washer	rondelle elastique		
15	740240-0-00	1	vite	screw	vis		
16	308113-0-00	1	anello	oil ring	bague d'étanchéité		
17	308126-0-00	1	guarnizione	gasket	garniture		
18	701051-0-00	1	guarnizione	gasket	garniture		
19	206545-0-00	1	molla a spirale	spring	ressort		
20	206559-0-00	1	filtro	oil filter	filtre huile		

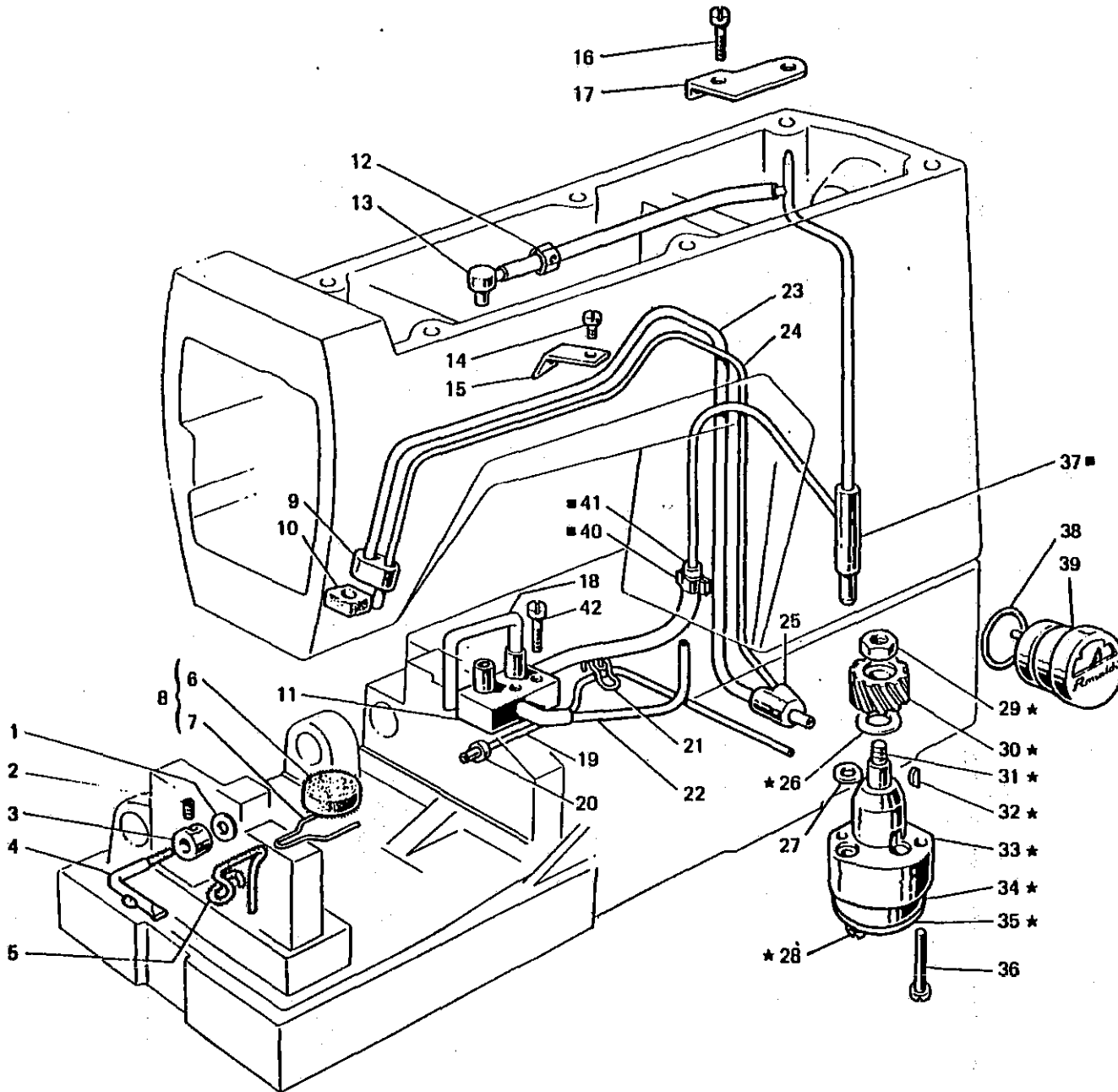

Fig. N. Abb. N.	Parl. N. Piece N. Bestell N. Pieza N.	Qt. Anzahl	DESCRIZIONE	DESCRIPTION	DESCRIPTION	BENENNUNG	DESCRIPCION
■	310500-4-00	1	raccordo mandata olio compl.	pipe union assembly	raccord complet		
★	308105-4-00	1	pompa olio completa	oil pump assembly	pumpe à huile complète		
1	300420-0-10	1	rondella	washer	rondelle		
2	730011-2-00	1	vite	screw	vis		
3	300419-0-10	1	raccordo	pipe union	raccord		
4	308243-3-00	1	tubetto e stoppino	pipe and wick	tube et mèche		
5	778240-0-00	1	stoppino	wick	mèche		
6	308153-0-00	1	filtro	filter	filtre		
7	308154-0-00	1	molletta	spring	ressort		
8	308155-4-00	1	gruppo molletta con filtro	spring with filter assembly	groupe ressort avec filtre		
9	308123-0-00	1	raccordo superiore	upper pipe union	raccord supérieur		
10	200853-0-10	1	striscia feltro	felt	feutre		
11	308114-2-00	1	distributore	distributor	distributeur		
12	308040-2-00	1	tubetto	pipe	tube		
13	308214-0-00	1	raccordo mandata olio	pipe union	raccord		
14	721424-2-00	1	vite	screw	vis		
15	308184-0-00	1	fascetta	clamp	bride		
16	721494-2-00	1	vite	screw	vis		
17	308104-0-00	1	piastrina	plate	plaquette		
18	790307-0-00	1	tubetto	pipe	tube		
19	790325-0-00	1	tubetto	pipe	tube		
20	308212-0-00	1	bussolina olio	bush	bague		
21	308211-0-00	2	clip	clip	clip		
22	790315-0-00	1	tubetto	pipe	tube		
23	790342-0-00	1	tubetto recupero olio	pipe	tube		
24	790242-0-00	1	tubetto recupero olio	pipe	tube		
25	308185-0-00	1	raccordo inferiore	lower pipe union	raccord inférieur		
26	704813-0-00	1	rondella	washer	rondelle		
27	701004-0-00	1	anello di tenuta	oil ring	bague d'étanchéité		
28	741082-2-00	2	vite	screw	vis		
29	733507-0-00	1	dado	nut	écrou		
30	206555-0-00	1	ingranaggio	gear	engrenage		
31	206552-2-00	1	albero completo	shaft assembly	arbre complet		
32	206557-0-00	1	chiavetta	key	clavette		
33	206551-0-00	1	corpo pompa	pump body	corps pompe		
34	308110-3-00	1	corpo pompa aspirante	suction pum body	corps pompe admission		
35	308111-0-00	1	coperchio pompa	pump cover	couvercle pompe		
36	741092-0-00	2	vite fissaggio pompa	pump fixing screw	vis fixation pompe		
37	308180-2-00	1	raccordo mandata olio	pipe union	raccord		
38	701032-0-00	1	anello di tenuta	oil ring	bague d'étanchéité		
39	206669-2-01	1	indicatore livello olio	oil level gauge	indicateur niveau huile		
40	308043-0-00	1	fascetta	clamp	bride		
41	308207-0-00	1	tubetto	pipe	tube		
42	721514-0-00	2	vite	screw	vis		

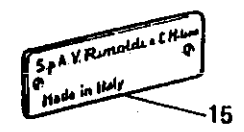
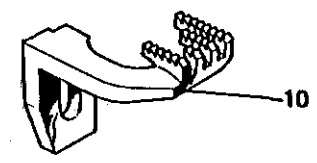
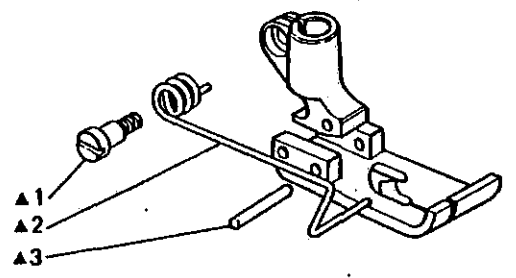
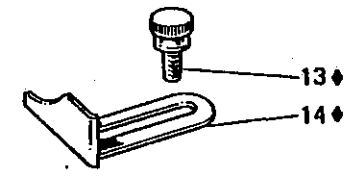
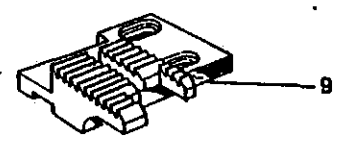
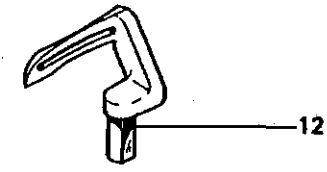
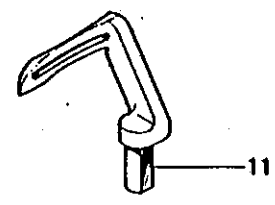
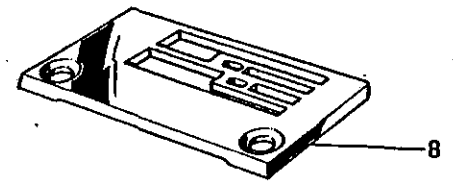
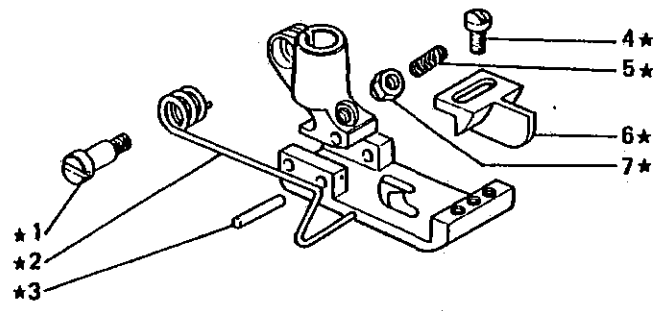

Fig. N. Abb. N.	Part. N. Bestell N. Pieça N. Pieça N.	Qt. Qnt.	DESCRIZIONE	DESCRIPTION	DESCRIPTION	BENENNUNG	DESCRIPCION
★	303679-3-01	1	pedino completo	presserfoot assembly	ped-presseur complet		
▲	301392-3-11	1	pedino completo	presserfoot assembly	ped-presseur complet		
◆	310013-4-00	1	guida completa	guide assembly	guide complet		
1	743265-2-00	2	vite	screw	vis		
2	301394-0-10	2	molla	spring	ressort		
3	301225-0-10	4	spina	pin	goupille		
4	100174-0-10	2	vite	screw	vis		
5	301596-0-11	1	vite	screw	vis		
6	303677-0-01	1	guida	guide	guide		
7	301598-0-11	1	dado	nut	écrou		
8	301391-0-20	1	placca ago	needle plate	plaque à aiguille		
9	301384-0-12	1	griffa principale	main feed dog	griffe principale		
10	301386-0-10	1	griffa differenziale	differential feed dog	griffe différentielle		
11	303664-0-11	1	crochet posteriore	rear looper	crochet arrière		
12	303665-0-11	1	crochet anteriore	front looper	crochet avant		
13	300917-0-10	2	pomofo	knob	pommeau		
14	301050-0-11	1	guida	guide	guide		
15	785755-0-20	1	targhetta classe testa	head class plate	plaque classe tête		

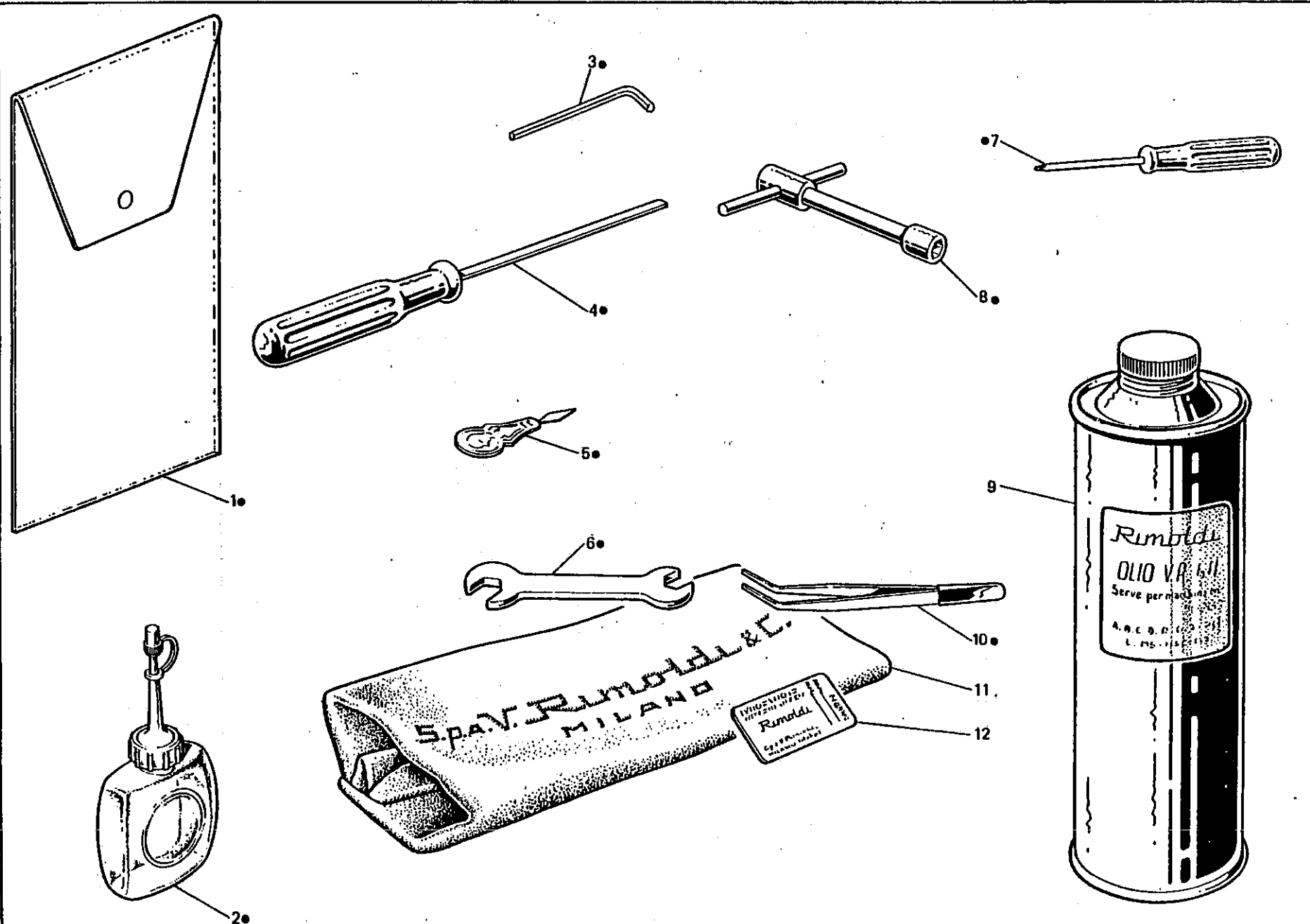

Fig. N. Abb. N.	Part. N. Piece N. Bestell N. Pieza N.	Qt. Anzahl	DESCRIZIONE	DESCRIPTION	DESCRIPTION	BENENNUNG	DESCRIPCION
●	991408-4-00	1	busta accessori completa	accessories envelope assembly	envelope accessoires complète		
1	991415-0-00	1	busta accessori	accessories envelope	envelope accessoires		
2	990175-0-10	1	oliatore	oiler	graisseur		
3	990474-0-10	1	chiave esagonale da 1,5 mm	1.5 mm hexagonal key	clé hexagonale de 1,5 mm		
4	990181-0-10	1	cacciavite medio	screw-driver	tournevis moyen		
5	990188-0-10	1	infila aghi	needle threading	enfiles aiguilles		
6	990193-0-00	1	chiave da 5-7 mm	5-7 mm key	clé de 5-7 mm		
7	990182-0-10	1	cacciavite piccolo	screw driver	petit tournevis		
8	990587-0-10	1	chiave a tubo da 9 mm	9 mm key	clé a tube de 9 mm		
9	990074-1-11	1	lattina olio kg. 1 (per Italia)	oil container (1 kg)	bidon huile de 1 kg		
	990075-1-11	1	lattina olio kg. 1 (per Estero)	oil container (1 kg)	bidon huile de 1 kg		
10	990176-0-10	1	pinze per infilatura	threading tweezers	pince pour infilage		
11	990578-0-12	1	cuffia protez. macchina	machine cover	couverture protection machine		
12	*	1	bustina aghi	needle packet	paquette aiguille		
			* per l'ordinazione della bustina citare lo stesso simbolo dell'ago montato sulla testa	to order packet of needles please specify symbol of needle fitted on machine	pour commander un sachet d'aiguille donner le symbol de l'aiguille montée sur la tête		

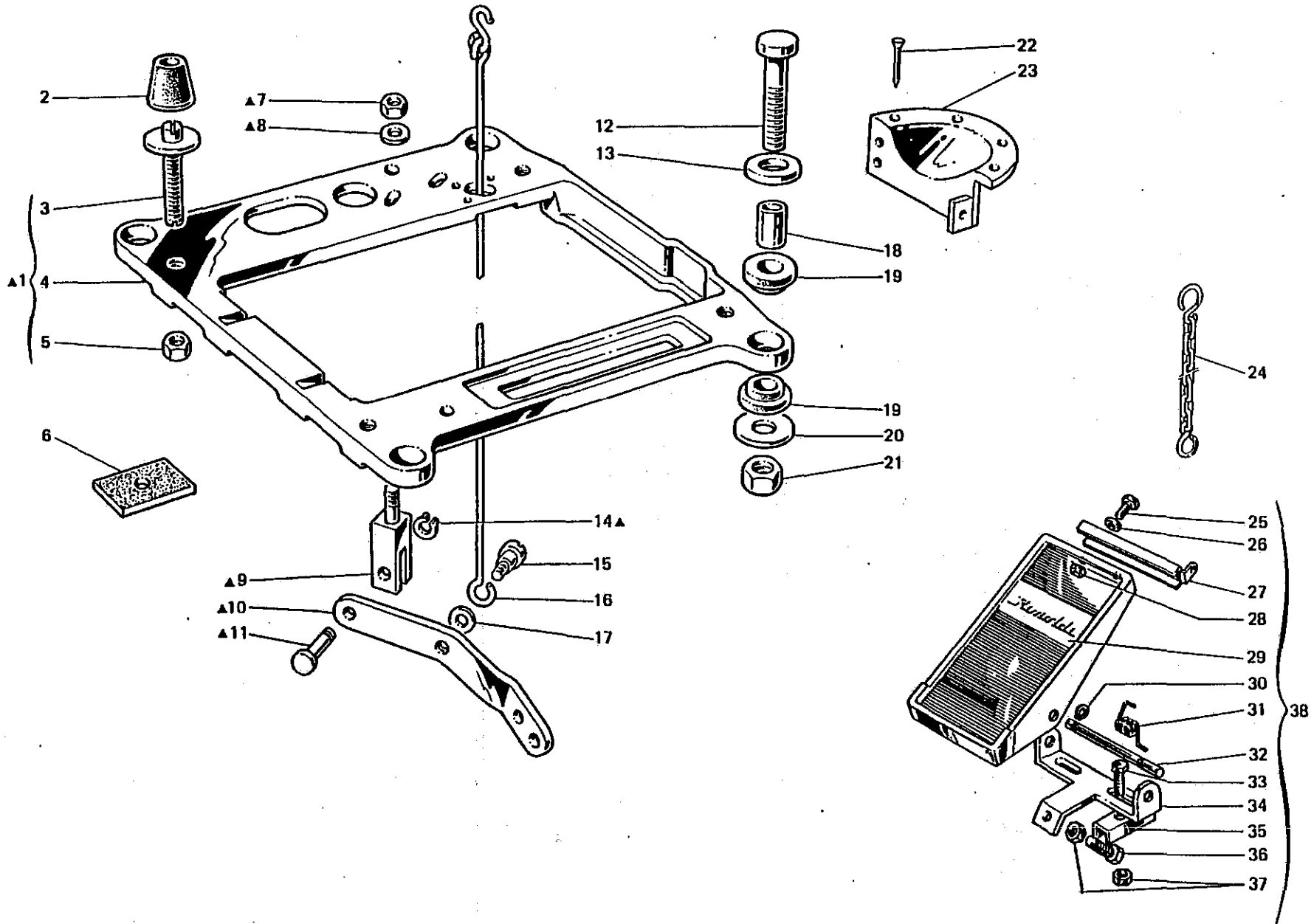

Fig. N. Abb. N.	Part. N. Bestell N. Pieza N.	Qt. Anzahl	DESCRIZIONE	DESCRIPTION	DESCRIPTION	BENENNUNG	DESCRIPCION
			PIAZZAMENTO NORMALE	NORMAL SETTING	INSTALLATION NORMAL		
A	991253-4-00	1	supporto testa completo	head support assembly	support tête complet		
1	991251-4-00	1	supporto testa con perno	head support with pin	support tête avec pivot		
2-	990982-0-00	4	ammortizzatore	shock absorber	amortisseur		
3	990694-0-11	4	perno	pin	pivot		
4	991250-0-00	1	supporto testa	head support	support tête		
5	733008-2-00	4	dado	nut	écrou		
6	900203-0-10	4	ammortizzatore per tavola	shock absorber	amortisseur pour table		
7	746409-2-00	1	dado	nut	écrou		
8	704316-2-00	1	rondella	washer	rondelle		
9	991256-0-00	1	supportino per leva	support for lever	support pour levier		
10	991255-0-00	1	leva	lever	levier		
11	991257-0-00	1	perno	pin	pivot		
12	722905-2-00	4	vite	screw	vis		
13	704346-2-00	4	rondella	washer	rondelle		
14	700208-0-00	1	anello elastico	spring ring	anneau ressort		
15	743541-2-00	1	vite	screw	vis		
16	991259-3-00	1	tirante	tie-rod	tirant		
17	704310-2-00	1	rondella	washer	rondelle		
18	901102-0-00	4	distanziale	spacer	entretoise		
19	901101-0-00	8	ammortizzatore	shock absorber	amortisseur		
20	704345-2-00	4	rondella	washer	rondelle		
21	733813-0-00	4	dado	nut	écrou		
22	900201-0-10	7	chiodini	rivets	clous		
23	990317-0-10	1	protezione volante	handwheel protection	protection volant		
24	990179-4-11	1	catenella	chain	chaînette		
25	720464-0-00	2	vite	screw	vis		
26	704009-0-00	2	rondella	washer	rondelle		
27	900926-0-00	1	attacco	coupling	raccord		
28	733508-4-00	2	dado	nut	écrou		
29	900931-0-00	1	copertura	covering	couverture		
30	900918-0-00	2	anello elastico	spring ring	anneau ressort		
31	900927-0-00	1	molla	spring	ressort		
32	900928-0-00	1	perno	pin	pivot		
33	720505-4-00	2	vite	screw	vis		
34	900929-0-01	1	supporto	support	support		
35	900920-0-00	2	piastrina	plate	plaquette		
36	720545-4-00	1	vite	screw	vis		
37	733510-4-00	3	dado	nut	écrou		
38	900925-4-01	1	pedalina completa	pedal assembly	pédale complète		

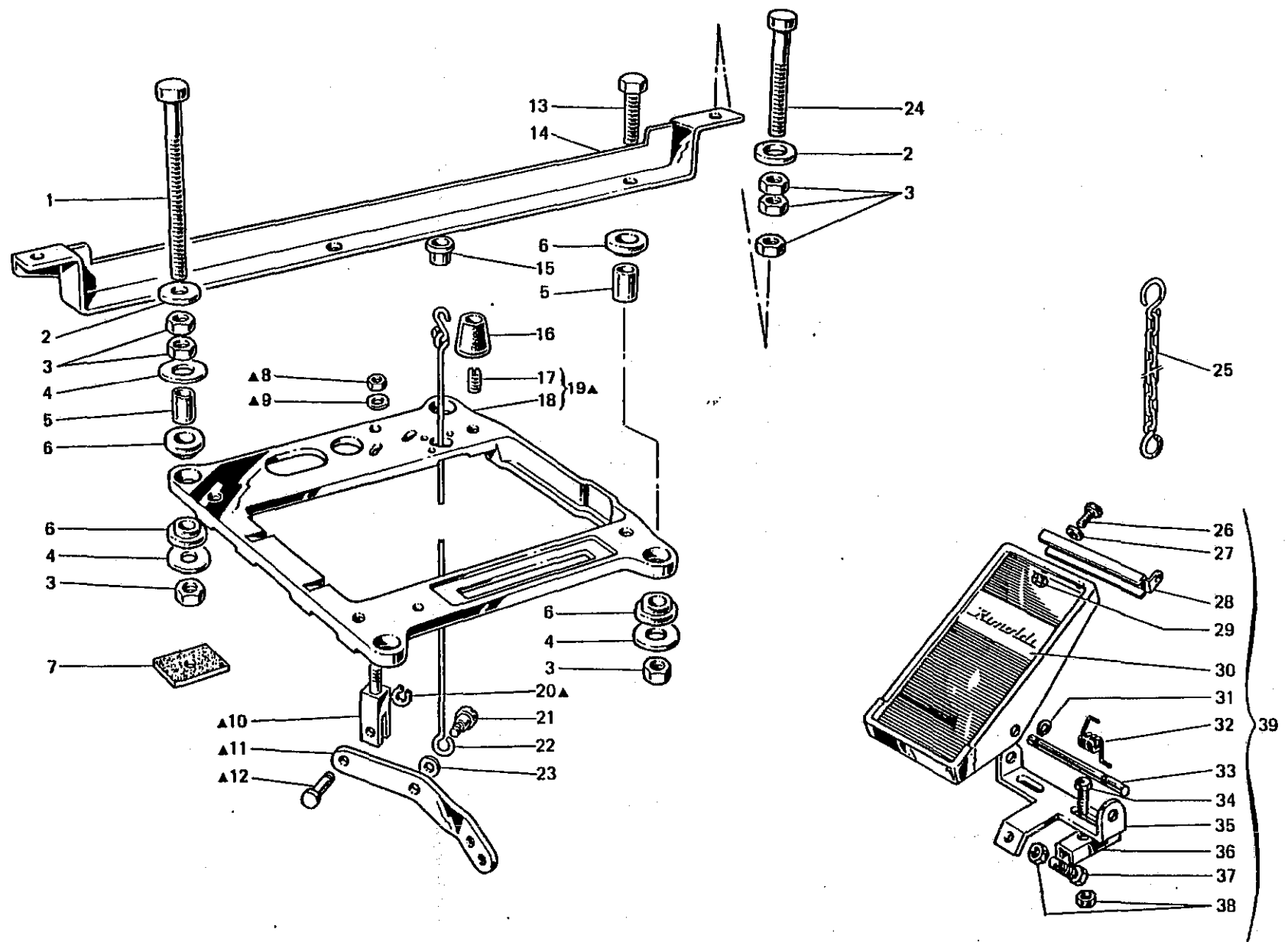

Fig. N. Abb. N.	Part. N. Bestell N. Piece N. Pieza N.	Qt. Anzahl	DESCRIZIONE	DESCRIPTION	DESCRIPTION	BENENNUNG	DESCRIPCION
A	991254-4-00	1	PIAZZAMENTO INCASSATO	SUBMERGED SETTING	INSTALLATION ENCASTREE		
1	722920-2-00	2	supporto testa completo	head support assembly	support tête complet		
2	704346-2-00	4	vite	screw	vis		
3	733813-0-00	14	rondella	washer	rondelle		
4	704345-2-00	6	dado	nut	écrou		
5	901102-0-00	4	rondella	washer	rondelle		
6	901101-0-00	4	distanziale	spacer	entretoise		
7	900203-0-10	8	ammortizzatore	shock absorber	amortisseur		
8	746409-2-00	4	ammortizzatore per tavola	shock absorber	amortisseur pour table		
9	704316-2-00	1	dado	nut	écrou		
10	991256-0-00	1	rondella	washer	rondelle		
11	991255-0-00	1	supportino per leva	support for lever	support pour levier		
12	991257-0-00	1	leva	lever	levier		
13	720546-0-00	1	perno	pin	pivot		
14	901251-2-00	2	vite	screw	vis		
15	900204-0-10	1	staffa	bracket	bride		
16	990982-0-00	1	bussola	bush	bague		
17	990982-0-00	4	ammortizzatore	shock absorber	amortisseur		
18	901253-0-00	4	vite	screw	vis		
19	991250-0-00	1	supporto testa	head support	support tête		
20	991252-4-00	1	supporto testa con viti	head support with screws	support tête avec vis		
21	700208-0-00	1	anello elastico	spring ring	anneau ressort		
22	743541-2-00	1	vite	screw	vis		
23	991259-3-00	1	tirante	tie-rod	tirant		
24	704310-2-00	1	rondella	washer	rondelle		
25	722907-2-00	2	vite	screw	vis		
26	990179-4-11	1	catenella	chain	chafnette		
27	720164-0-00	2	vite	screw	vis		
28	704009-0-00	2	rondella	washer	rondelle		
29	900926-0-00	1	attacco	coupling	raccord		
30	733508-4-00	2	dado	nut	écrou		
31	900931-0-00	1	copertura	covering	couverture		
32	900918-0-00	2	anello elastico	spring ring	anneau ressort		
33	900927-0-00	1	molla	spring	ressort		
34	900928-0-00	1	perno	pin	pivot		
35	720505-4-00	2	vite	screw	vis		
36	900929-0-01	1	supporto	support	support		
37	900920-0-00	2	piastrina	plate	plaquette		
38	720545-4-00	1	vite	screw	vis		
39	733510-4-00	3	dado	nut	écrou		
39	900925-4-01	1	pedalina completa	pedal assembly	pédale complète		

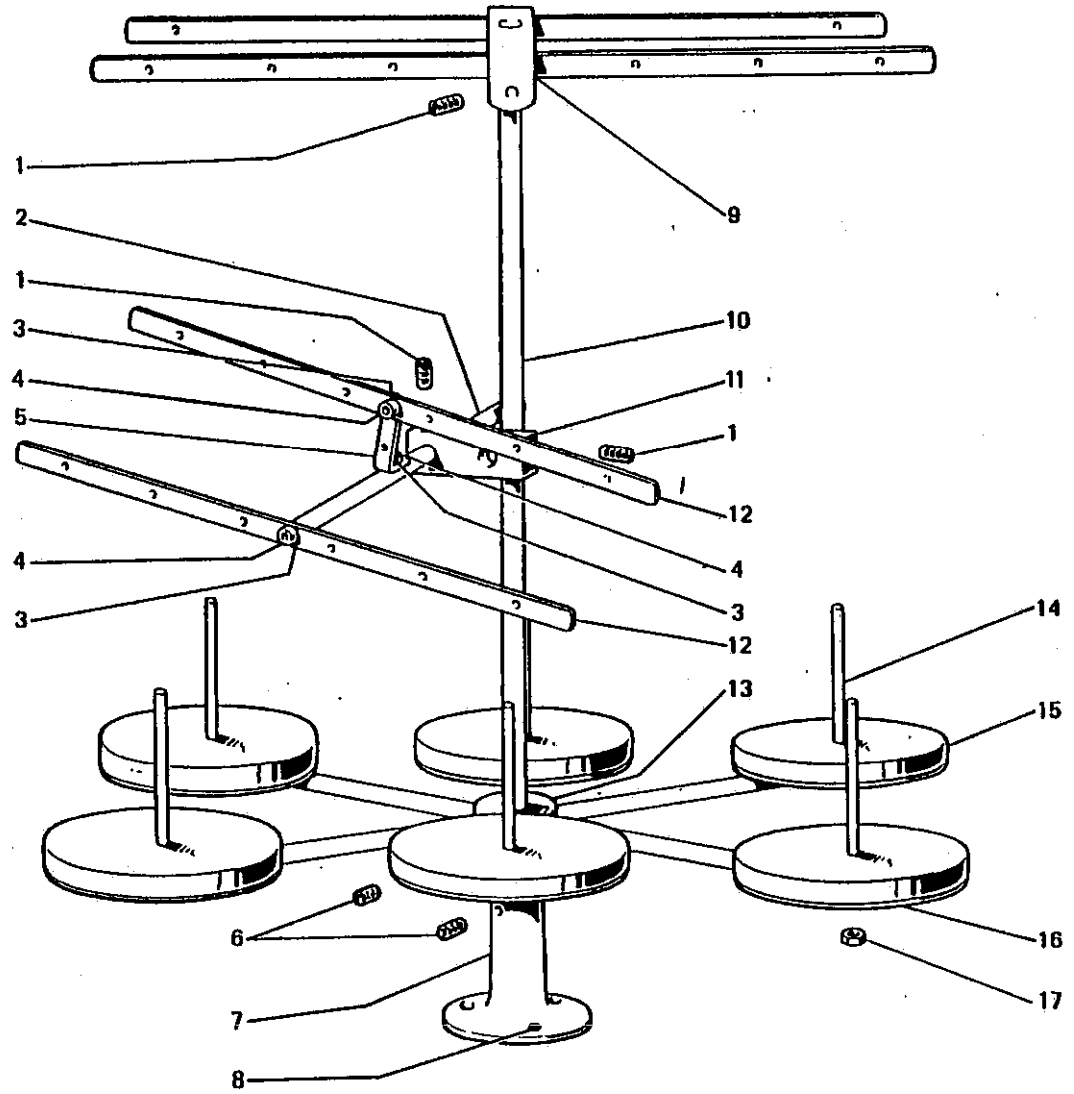

Fig. N. Abb. N.	Part. N. Bestell N. Pieze N.	Qt. Anzahl	DESCRIZIONE	DESCRIPTION	DESCRIPTION	BENENNUNG	DESCRIPCION
-	991135-5-00	1	gruppo porta bobine a 6 p.	bobbin holder assembly	groupe porte bobines		
1	729034-2-00	3	vite	screw	vis		
2	991106-2-00	1	asta	rod	tige		
3	703005-0-00	3	rondella	washer	rondelle		
4	722431-2-00	3	vite	screw	vis		
5	991107-2-00	1	squadretta	bracket	équerre		
6	729054-2-00	3	vite	screw	vis		
7	991114-2-00	1	basetta	base	base		
8	731107-2-00	3	vite da legno	screw	vis		
9	991139-3-00	1	telaletto super. completo	upper frame assembly	bâti supérieur complet		
10	991113-0-00	1	asta principale	main rod	tige principale		
11	991128-2-00	1	blocchetto	block	bloc		
12	991137-2-00	2	telaletto con bussole	frame with bushes	bâti avec bagues		
13	991144-3-00	1	mozzo con aste	hub with pins	moyeu avec tiges		
14	991111-2-00	6	astina	rod	petite tige		
15	991179-0-00	6	disco antivibrante	disc	disque		
16	991112-0-00	6	piatto	disc	plateau		
17	733508-2-00	12	dado	nut	écrou		

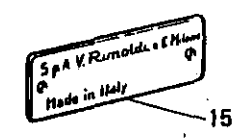
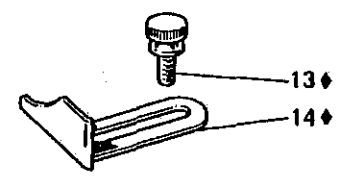
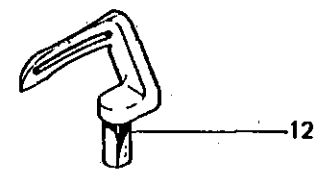
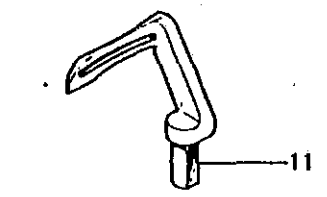
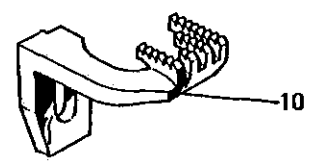
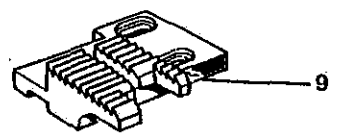
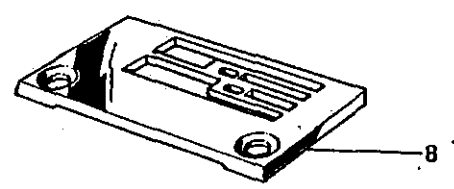
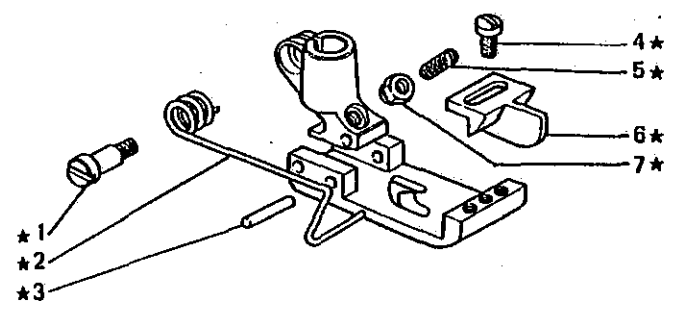

Fig. N. Abb. N.	Part. N. Bestell N. Pieza N.	Qt. Pezzi	DESCRIZIONE	DESCRIPTION	DESCRIPTION	BENENNUNG	DESCRIPCION
45	<u>Tav. 4</u> 302842-0-10	1	squadretta	bracket	équerre		
A 44	<u>Tav. 9</u> 309852-4-00 309760-2-00	1 1	morsetto porta aghi compl. morsetto porta aghi	needles clamp assembly needles clamp	porte-aiguilles complet porte-aiguilles		
★	307392-3-01	1	pedino completo	presserfoot assembly	pled-presseur complet		
◆	310013-4-00	1	guida completa	guide assembly	guide complet		
1	743265-2-00	1	vite	screw	vis		
2	301394-0-10	1	molla	spring	ressort		
3	301225-0-10	2	spina	pin	goupille		
4	100174-0-10	2	vite	screw	vis		
5	301596-0-11	1	vite	screw	vis		
6	303677-0-01	1	guida	guide	guide		
7	301698-0-11	1	dado	nut	écrou		
8	307384-0-00	1	placca ago	needle plate	plaque à aiguille		
9	307378-0-01	1	griffa principale	main feed dog	griffe principale		
10	307379-0-00	1	griffa differenziale	differential feed dog	griffe différentielle		
11	303664-0-11	1	crochet posteriore	rear looper	crochet arrière		
12	307381-0-01	1	crochet anteriore	front looper	crochet avant		
13	300917-0-10	2	pomolo	knob	pommeau		
14	301050-0-11	1	guida	guide	guide		
15	785701-0-20	1	targhetta classe testa	head class plate	plaque classe tête		