

INSTRUCTIONS AND PARTS BOOK
FOR

Columbia[®]

HIGH SPEED, SINGLE NEEDLE,
REVERSE FEED
LOCKSTITCH MACHINE
MODEL N430-2

MANUFACTURED FOR
AND

DISTRIBUTED BY

Union Special[®]
CORPORATION

400N. FRANKLIN STREET
CHICAGO U. S. A.
60610

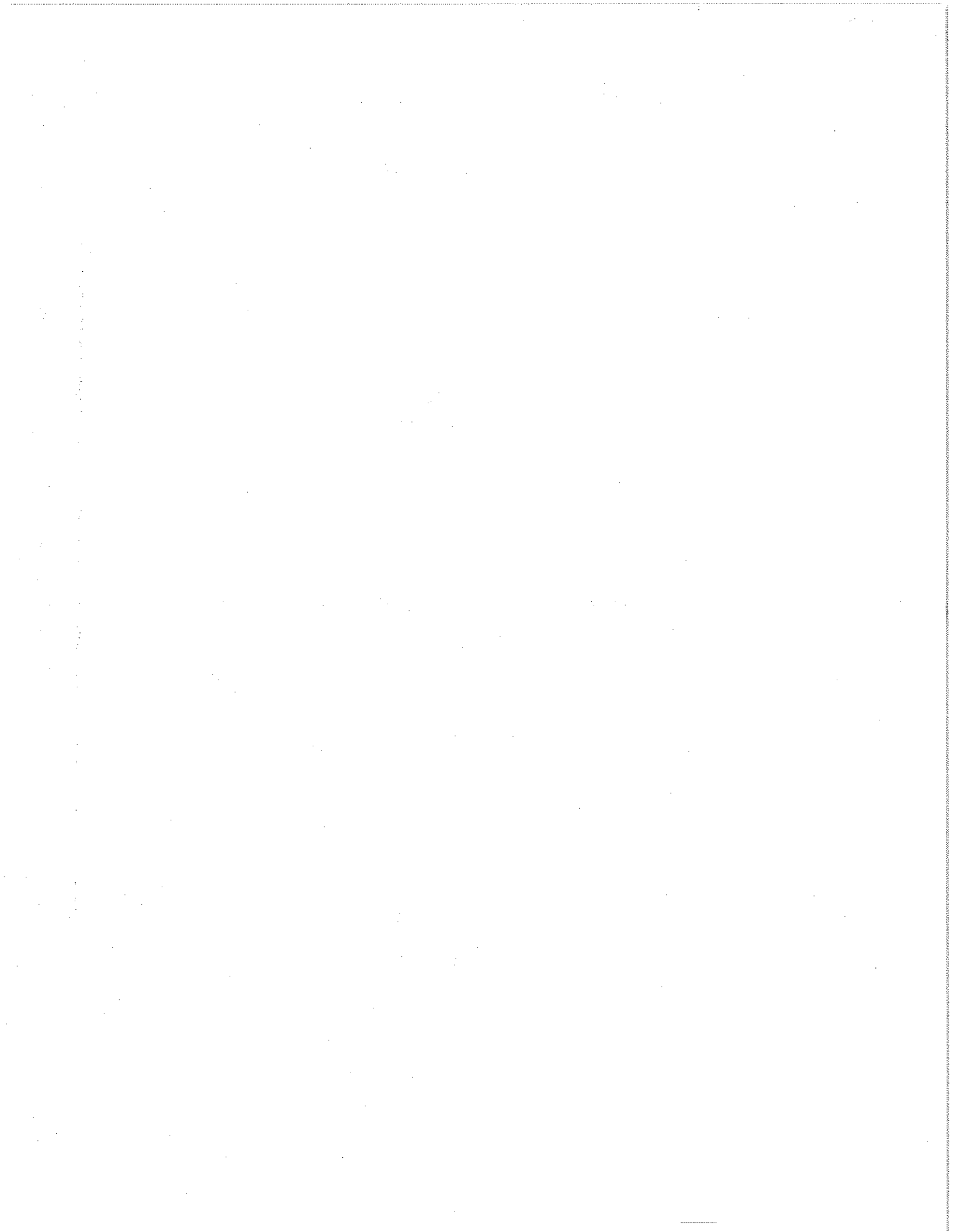

INDEX

I	Specifications	2
II	Names of Main Parts	3
III	How to mount and adjust the knee lifter	4
IV	Precautions before starting operation of machine	5
V	How to use the machine	6
	1) How to insert needle	6
	2) How to operate the bobbin winder	6
	3) Threading	7
	4) Adjustment of stitch length & reverse lever	7
	5) Adjustment of presser foot pressure	7
	6) How to use the machine	8
	7) How to remove material after stitching or chaining off	8
	8) Adjustment of thread tension	9
	9) Upper thread tension	9
	10) Bobbin thread tension	9
	11) Adjustment of hook oil lubrication	9
	12) Adjustment of oil pump	9
VI	Problem & Solution Check List	10
VII	Parts book	11

● Revised July 1, 1978.

Applies particularly to machines after serial No. U-326801.

INSTRUCTIONS FOR HIGH SPEED INDUSTRIAL SEWING MACHINE

This booklet is a guide to the proper use of the high speed industrial sewing machine. This single needle lock stitching machine is specially designed for operation at 4,500 stitches a minute and has an automatic oiling system. The main parts of this machine is made of special steel. In this lubricating system, oil is automatically supplied to the major moving parts enabling a continuous operation of the machine at greatest efficiency without fear of overheating.

SPECIFICATIONS

Sewing material	General cloth
Recommended top speed	4,500 s.p.m.
Needle bar stroke	30.5 mm
Thread take-up	Link motion type
Stitch length	0 – 5 mm
Stitch length adjustment	Dial regulator type
Reverse sewing	Spring return lever type
Presser bar stroke	13 mm
Lubrication	Full automatic force feed lubrication
Oil check window	Oil jet indicating type
Oil back flow device	Plunger pump type
Oil tank	Separate from the head
Rotating hook	Full rotating automatic oiling high speed hook
Lubrication for hook	Adjustable screw type
Knee lift device	Link type built-in arm
Lubrication oil	White spindle oil

- 45
- 44
- 43
- 42
- 41
- 40
- 39
- 38
- 37
- 36
- 35
- 34
- 33
- 32
- 31

- 1) S
- 2) A
- 3) P
- 4) L
- 5) L
- 6) C
- 7) C
- 8) C
- 9) F
- 10) C
- 11) E
- 12) L
- 13) S
- 14) V
- 15) F

Names of main parts

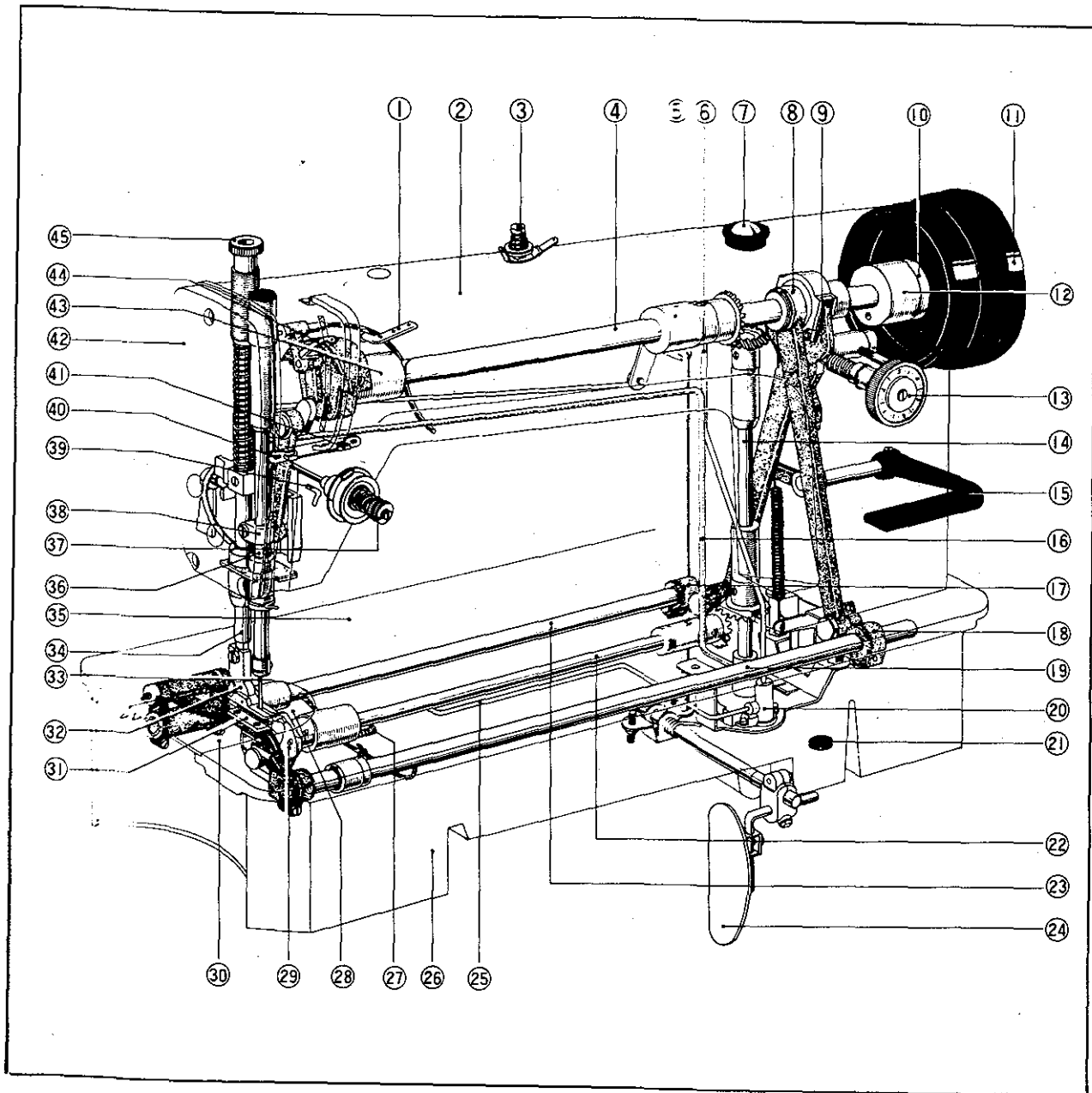

- | | | |
|--------------------------------|-----------------------------------|-------------------------------------|
| 1) 3-hole thread guide | 16) Oil back flow pipe | 31) Feed dog |
| 2) Arm | 17) Feed rock shaft crank | 32) Presser foot |
| 3) Pre-tension | 18) Feed lifting rock shaft crank | 33) Needle (DBx1) |
| 4) Upper shaft | 19) Feed lifting rock shaft | 34) Presser bar |
| 5) Upper shaft bushing(center) | 20) Oil pump case | 35) Machine bed |
| 6) Oil pipe(upper shaft) | 21) Magnet | 36) Needle bar |
| 7) Oil check window | 22) Lower shaft | 37) Upper thread tension regulator |
| 8) Crank rod | 23) Feed rock shaft | 38) Needle bar holder |
| 9) Feed forked connection | 24) Knee lifter | 39) Upper thread guide |
| 10) Oil seal | 25) Oil pipe(for hook) | 40) Thread guide(face plate) |
| 11) Balance wheel | 26) Oil tank | 41) Thread guide(arm) |
| 12) Upper shaft bushing(right) | 27) Oil lubrication control ring | 42) Face plate |
| 13) Stitch regulating dial | 28) Throat plate | 43) Upper shaft bushing(left) |
| 14) Vertical shaft | 29) Hook | 44) Thread take-up lever |
| 15) Reverse stitch lever | 30) Slide plate(set) | 45) Pressure regulating thumb screw |

How to mount and adjust the knee lifter

III Mounting & Adjustment of knee lifter

1) How to mount:

- (1) Place the oil tank as shown in Fig.
 - (2) Mount the knee plate bar bracket to the end of the knee lifter rock shaft by bolt (A).
 - (3) Insert the shorter part of knee plate bar into the hole of knee plate bar bracket and tighten the bolt (B).
 - (4) Then tighten the knee plate by bolt (C) as shown in Fig.
- o Place the machine head onto the oil tank on which the knee lifter mechanism is mounted, and move the knee plate to right and left so that the presser foot lifts and down accordingly.
 - o Adjustable screws (D) & (E) fixed on the knee lifter rock shaft crank are for purpose of adjustment of the knee lifter operation to be not worked excessively. Please adjust that screws properly.

2) How to adjust:

o Screw D:

- (1) Lift the presser foot by the presser bar lifter fixed on the machine head.
- (2) Move the knee plate of knee lifter mechanism to right so that the presser foot lifts slightly. Then stop moving the knee plate at the position where the presser bar lifter moves downwards naturally.
- (3) At the same time, adjust the screw (D) so that the tip of screw would come in contact with the oil tank.

o Screw E:

- (1) Release the knee plate slowly from right to the former position.
- (2) Stop the knee plate of the position where the presser foot comes in contact with the needle plate.
- (3) At the same time, adjust the screw (E) so that the tip of screw would come in contact with the oil tank.

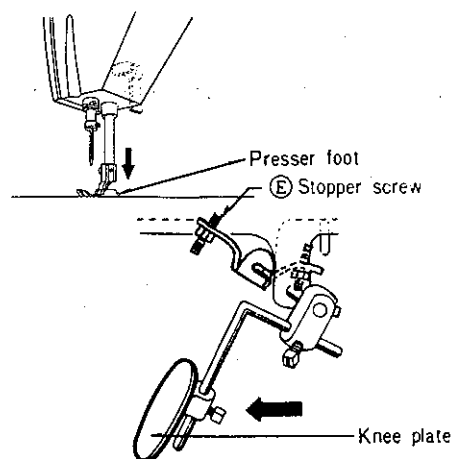
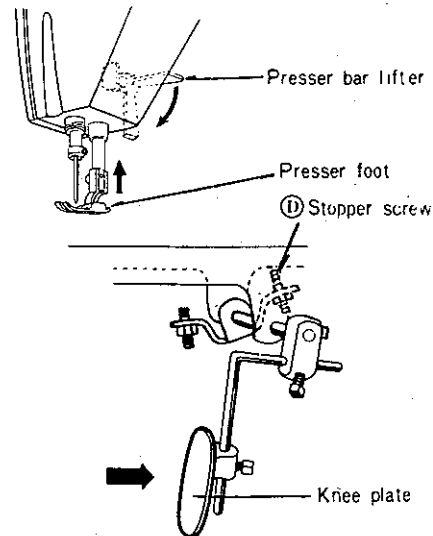
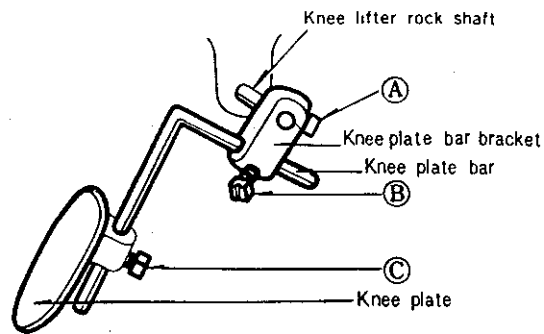

1) L
E
P
Y
P
V
F
3) C
C
S
C
4) I
*

Precautions before starting operation of machines

1) Lubrication-1

Before starting to operate pour oil upto the position (A) of oil tank. While operating you are requested to check the oil volume periodically, and in case of oil volume would come less than the position (B) replenish oil upto the position (A).

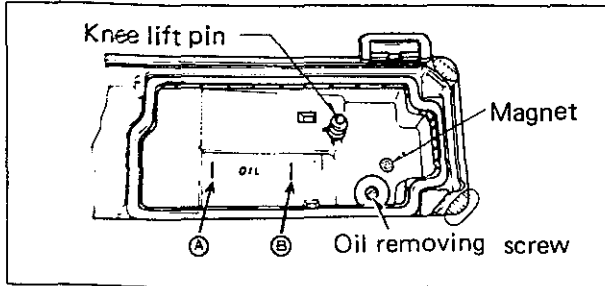

2) Lubrication-2

When first starting to sew, and after the machine has been at rest for a period of time, it is essential to hand oil the machine through holes painted red.

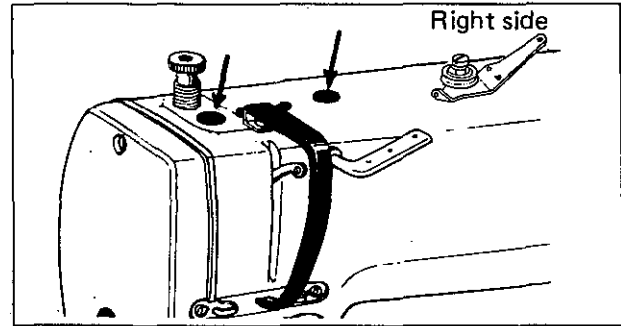

3) Condition of oil lubrication

Oil flow - while operating machine, check to see that there is a flow of oil visible in the oil check window.

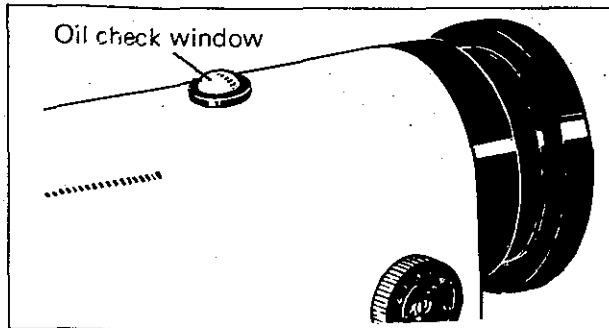

4) Periodical cleaning *Remove the throat plate and clean the feed dog.

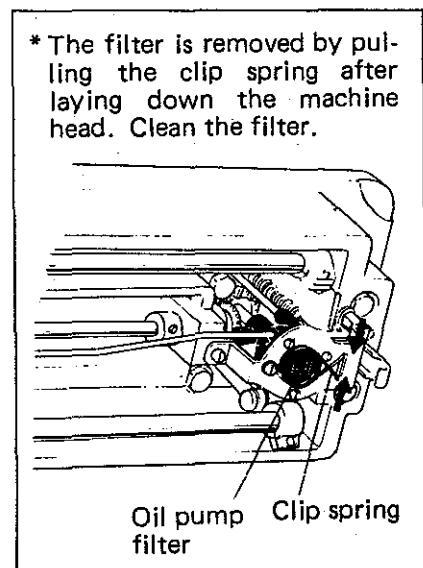
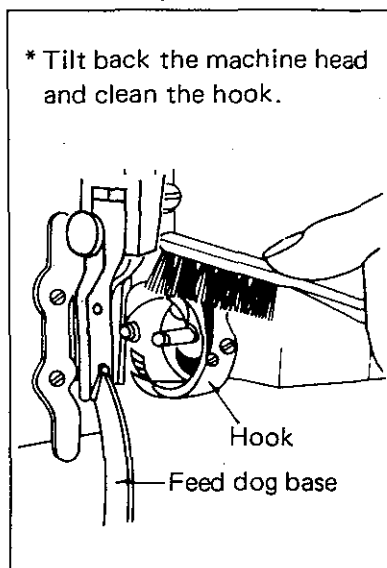
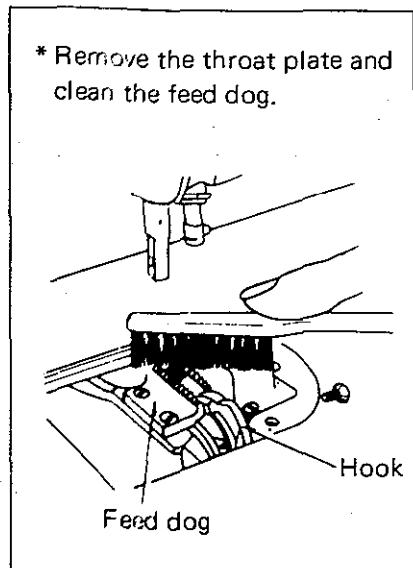

How to use the machine

1) How to insert needle-

Note: Before making the following adjustment, switch off the power source.

3)

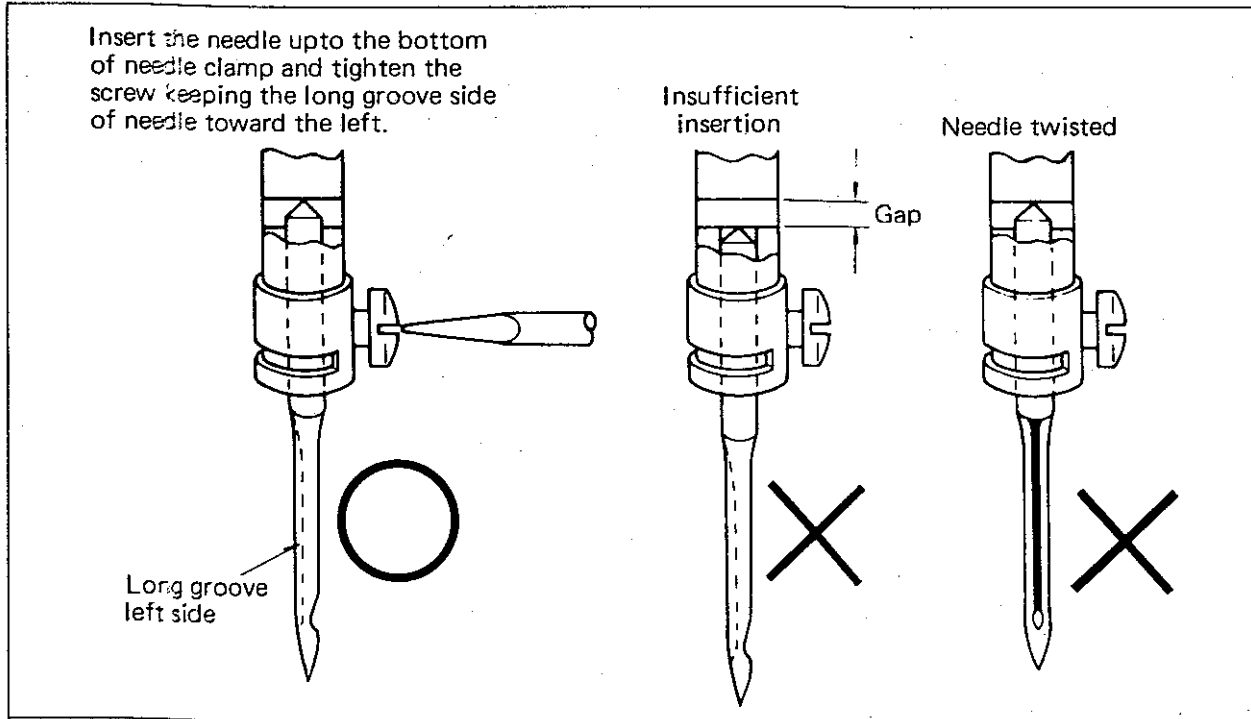

2) How to operate the bobbin winder:

Note: In the event it is necessary to run the machine without material, raise the presser foot to avoid contact with feed dog.

- Adjustment:
- * Thread tension — Particularly in case of nylon or synthetic thread, it is desirable that the bobbin be wound loosely.
 - * Uneven winding — In case of uneven winding, adjust the thread guide slightly toward the least wound part of bobbin to obtain even winding.
 - * Adjustment for bobbin fullness
 - 1) If the bobbin is too full, turn adjusting screw counterclockwise.
 - 2) If the bobbin is not full enough, turn adjusting screw clockwise.

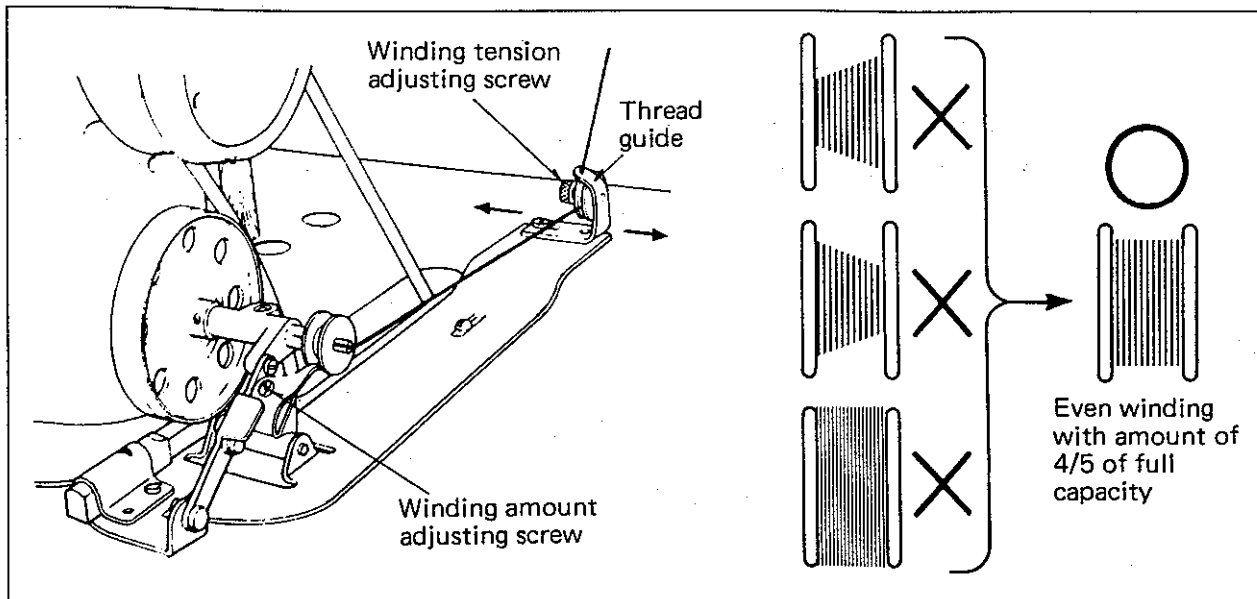

4)

No

70

How to use the machine

3) Threading

Raise the thread take-up lever to its highest position and thread the upper thread in the following order.

Note: The thread guide (A) of thread stand is to be directly above of spool.

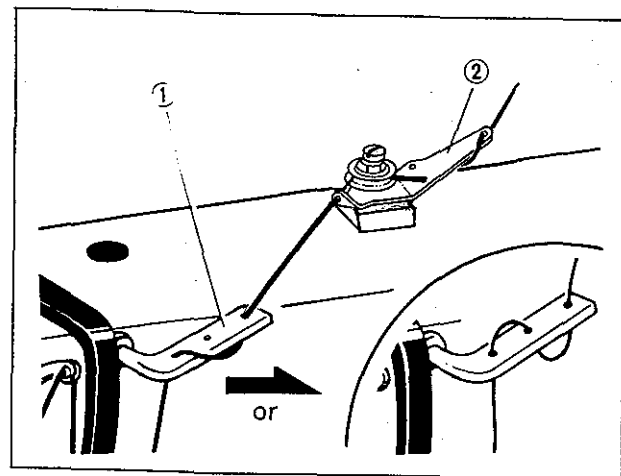
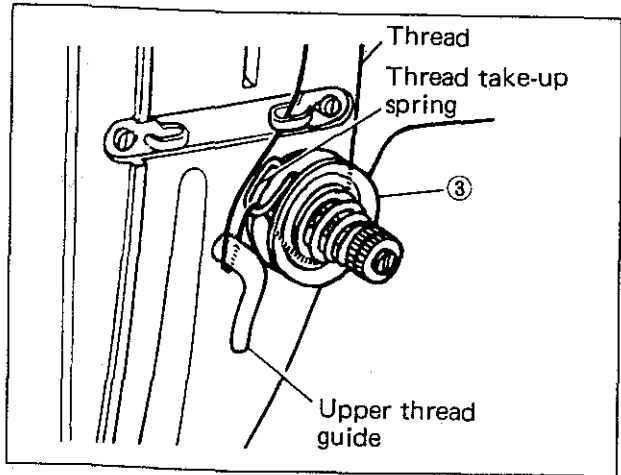
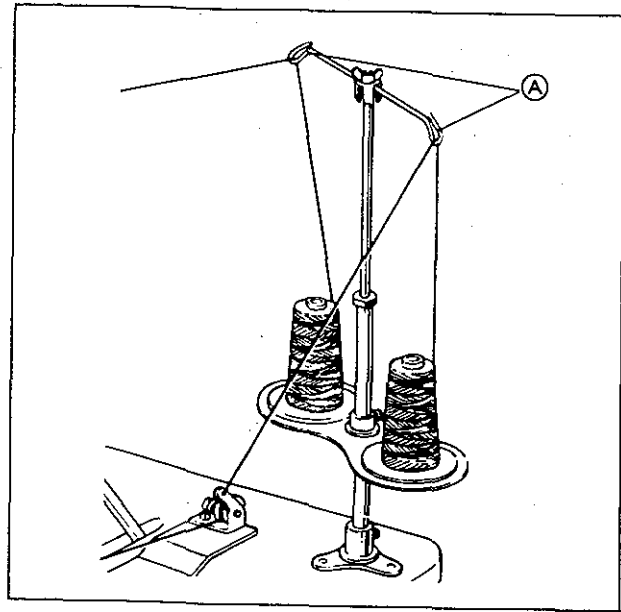
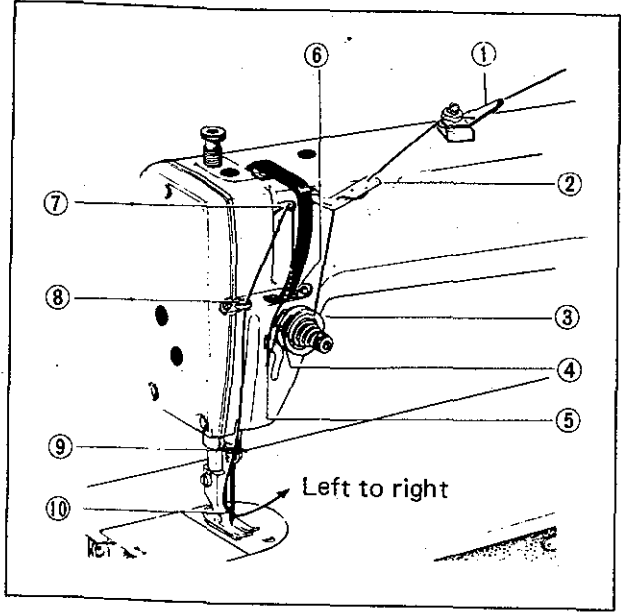

4) Adjustment of stitch length & reverse lever

Note: For desired stitch length, push the reverse lever downward and adjust by stitch length adjusting dial.

5) Adjustment of presser foot pressure :

Pressure on the presser foot is to be adjusted in accordance with materials to be sewn.

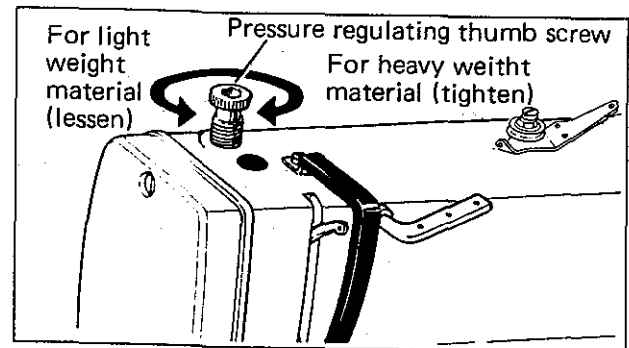
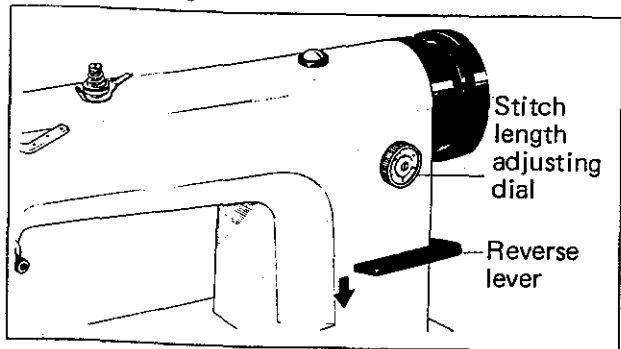

How to use the machine

6) How to use the machine:

- (1) Lift the presser foot.
- (2) Holding the end of the upper thread with left hand and turn the hand wheel slowly.
- (3) After 1 rotation of the hook, the upper thread is pulled out drawing the lower thread through the hole of the throat plate shown in Fig.
- (4) Pull the lower thread to over and under of the presser foot as shown in Fig.
- (5) Place material to be sewn under the needle.
- (6) Turn the hand wheel toward you so that the needle enters the material.
- (7) Then lower the presser foot and start to sew.

When starting to sew, please leave the upper thread pulled out by approx. 10 cm in length so as not to pull out.

Remember that if you start to sew rapidly from the beginning after down the presser foot, the thread happens to cut.

The beginning 4 – 5 stitches should be started to sew slowly and then increase the speed gradually.

7) How to Remove Material after Stitching on Chaining off:

- (1) When sewing off the take-up lever should be lift at its highest position.
- (2) Lift the presser foot.
- (3) Pull out the sewn fabric diagonally to the left.
- (4) Trim both of the upper and lower thread.

If the take-up lever is down and the fabrics is removed, the upper thread will be cut by hook, and the needle will be bent & the hook damaged.

When sewing-off it is recommended that the upper thread pulled out about 10cm length for case in starting the next garment.

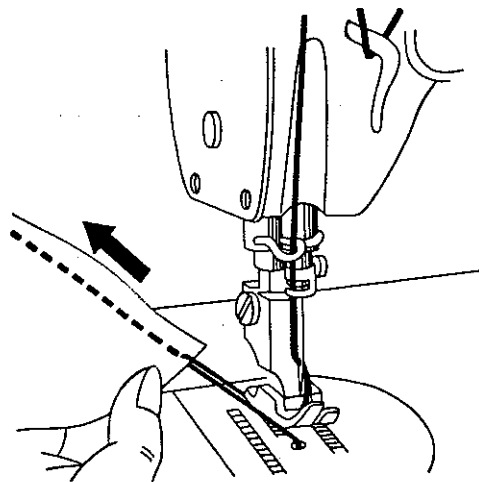
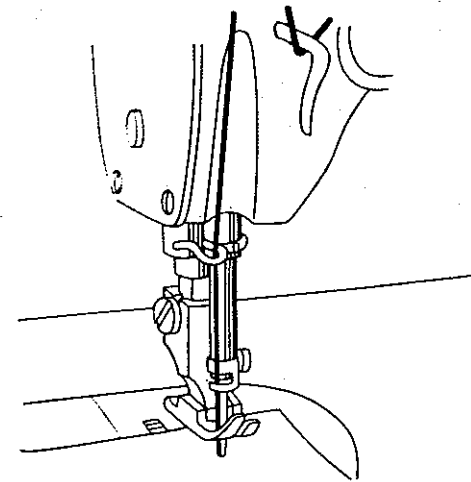
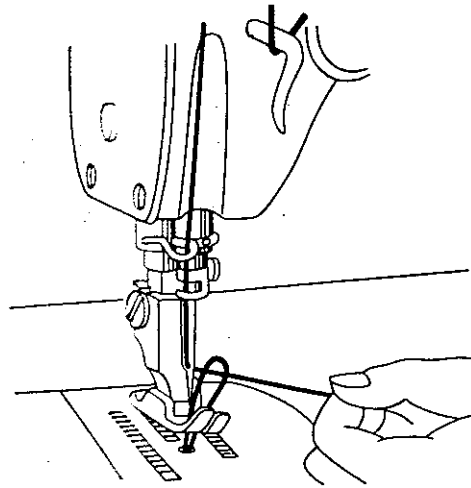

8)

9)

10

T
S

1

A
S

+

*

How to use the machine

8) Adjustment of thread tension:

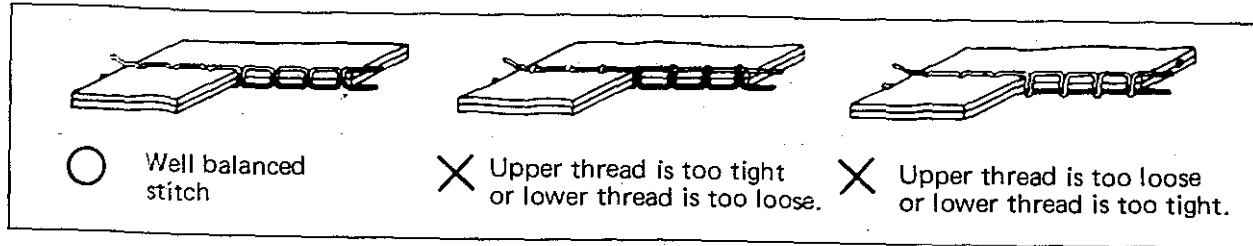

9) Upper thread tension:

- ** Upper thread is adjusted according to the lower thread tension.
- ** Upper thread tension is adjusted by tension regulating thumb nut.

For sewing on special fabric with special thread, the desired tension can be obtained by adjusting the height and tension of the thread take-up spring.

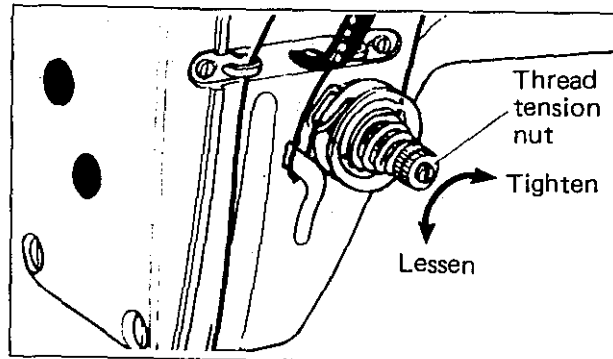

10) Bobbin thread tension:

Thread tension spring

Increase tension

Lessen tension

A

Lower thread tension can be adjusted by screw A.

In case of cotton thread #60, the regular thread tension can be checked as the following. Hold the end of pulled out thread, and if the bobbin case fall slowly, the proper tension is obtained.

Rotation of bobbin

11) Adjustment of hook oil lubrication:

Adjustment is made by loosening the screw A within the range of three turns.

- ** In case of tightening the screw
..... maximum
- ** In case of loosening the screw
three times minimum

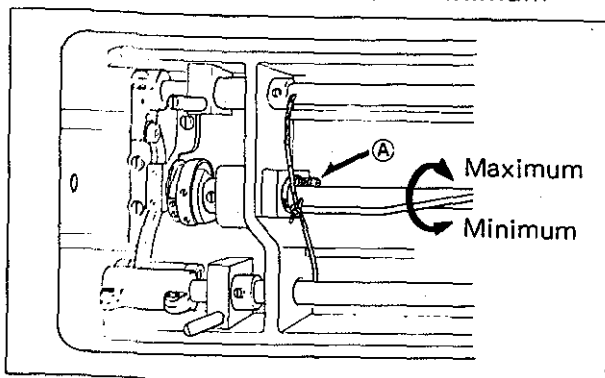

Problem & Solution Check List

Problem	Cause	Solution
Skip stitches	(1) Needle *Bent *Not right size for thread	Change needle. Replace needle with one of proper size.
	(2) Wrong needle *Needle not inserted all the way *Needle twisted *Needle in backwards	Replace with proper needle. Insert as per instructions Page 2, Item 1.
Loose stitch on top	<ul style="list-style-type: none"> • Needle thread too tight. • Bobbin thread too loose. 	Loose needle thread tension. Tighten bobbin thread tension.
Loose stitch on bottom	<ul style="list-style-type: none"> • Needle thread too loose. • Bobbin thread too loose. 	Tighten needle thread tension. Tighten bobbin thread tension.
Breaking thread	<ul style="list-style-type: none"> • Needle thread tension too tight. • Lint between tension disc. • Excessive or uneven winding bobbin. • Lint deposits in bobbin case. • Damaged thread tension spring on bobbin case. • Bobbin inserted wrong into bobbin case. 	Loosen needle thread tension. Remove tension discs and clean. Rewind correctly with the bobbin wound to 4/5 of its full capacity. Remove and clean with brush. Replace. Replace bobbin, so it rotates clockwise when the bobbin thread is pulled out.
Puckering	(1) Needle and thread too big for fabric	Change to proper size needle and thread.
	(2) Thread tensions not balanced.	Adjust tensions until a uniform stitch is obtained.
	(3) Too much pressure on presser foot	Loosen pressure.

**PARTS BOOK
FOR
HIGH SPEED, SINGLE NEEDLE,
LOCK STITCH MACHINE
MODELS N430-2 & N430-3**

— 11 —

Remarks: When ordering parts, be sure to include model number, parts number and its figure number.

- Revised July 1, 1978.

Applies particularly to machines after serial No. U-326801.

ARM BED & ITS ACCESSORIES

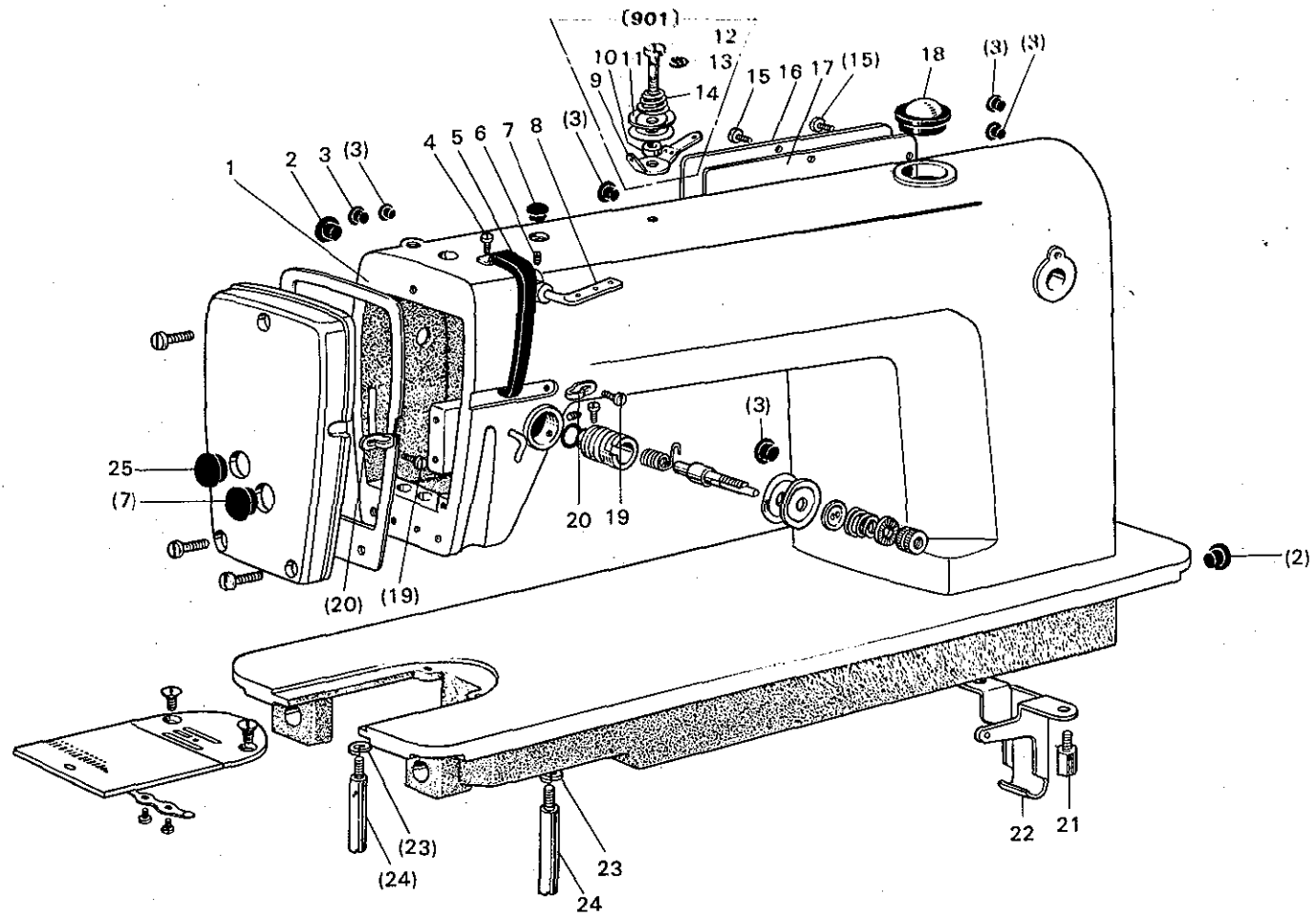

ARM BED & ITS ACCESSORIES

Fig. No.	Parts No.	Ref. No.	Description	Amt. Req.
1	MF 70E0 164	W229939G01	Arm & bed	1
2	M9 1900 080	W501374H01	Rubber plug (19 ϕ)	2
3	M9 0880 080	W501320H01	Rubber plug (8.8 ϕ)	5
4	M9 1107 002	W500092H01	Screw (for Fig. 5) 11/64(40) x 5.5	2
5	MF 10A0 584	W468291H01	Thread take-up cover	1
6	M9 1108 001	B503846H01	Set screw (for Fig. 8) 11/64(40) x 5.5	1
7	M9 1180 080	W502069H01	Rubber plug (11.8 ϕ)	2
8	MF 10A0 180	B409034H01	Three hole thread guide	1
9	MF 70A0 180	W481446H01	Thread guide for pre-tension	1
10	MF 20A0 476	W470268H01	Spacer for pre-tension	1
11	MF 10A1 555	W501636H01	Tension discs for pre-tension	2
12	M9 1104 016	W470267H01	Screw type tension stud	1
13	M9 0503 065	S592411H03	E-type stop ring	1
14	MF 20A0 245	W475419H01	Tension spring for pre-tension	1
901	MF 70E0 550	W341647G01	Pre-tension complete	1
15	M9 1101 004	W466810H01	Screw (for Fig. 16) 11/64(40) x 8	6
16	MF 70A0 880	W341642H01	Arm side cover	1
17	MF 70A0 691	W341643H01	Gasket (for Fig. 16)	1
18	MF 20A0 135	P674006X01	Oil check window	1
19	M9 0909 003	W501901H01	Screw (for Fig. 20) 9/64(40) x 6	1
20	MF 10A0 181	W452151H01	Arm & face plate thread guide	2
21	M9 1502 031	W481675H01	Special bolt 15/64(28) x 25	2
22	MF 70A0 150	W481676H01	Leg (right)	1
23	M9 0621 053	S561111H02	Spring washer (for Fig. 24)	2
24	MF 10A0 151	W452343H01	Leg (left)	2
25	M9 5002 080	W472710H01	Rubber plug (black 19 ϕ)	1

ARM BED & ITS ACCESSORIES

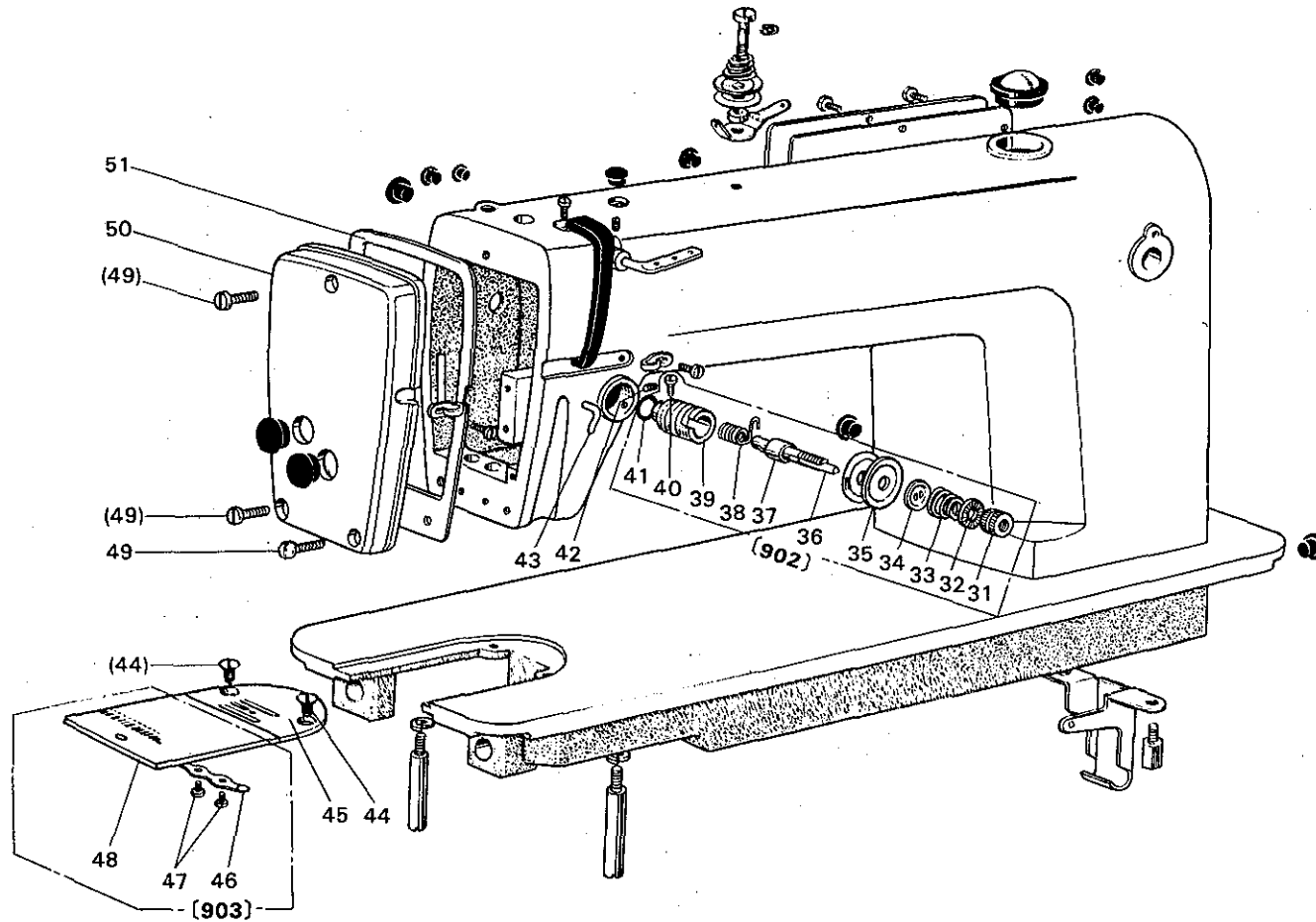

ARM BED & ITS ACCESSORIES

Fig. No.	Parts No.	Ref. No.	Description	Amt. Req.
31	M9 1608 046	W476469H01	Thread tension regulating thumb nut	1
32	MT 60A0 802	W476470H01	Thumb nut revolution stopper	1
33	MF 11D0 245	W461780H01	Thread tension spring	1
34	MM 11A0 556	W477611H01	Thread tension releasing disc	1
35	MF 10A0 555	W444059H01	Thread tension discs	2
36	M9 0204 060	B509216H01	Thread tension releasing pin	1
37	MF 10A0 553	B419178H01	Thread tension stud	1
38	MF 10A0 187	W475488H01	Thread take-up spring	1
39	MF 10A0 709	W453140H01	Thread tension regulator bushing	1
40	M9 0901 002	W500741H01	Set screw (for Fig. 37)	1
41	M9 1501-085	P648001X01	Rubber ring (for Fig. 39)	1
902	MF 70E0 210	W462751G02	Thread tension regulator complete	1
42	M9 1508 001	B509088H01	Set screw (for Fig. 902) 15/64(28) x 8	1
43	MF 70A1 180	W481679H01	Thread guide (under)	1
44	M9 1104 011	B508843H01	Screw (for Fig. 45)	2
45	MF 11D1 101	W328830H01	Needle plate	1
46	MF 10A0 471	B419207H01	Spring (for Fig. 48)	1
47	M9 0604 002	B509070H01	Screw (for Fig. 46) 3/32(56) x 2.2	2
48	MF 70A0 470	W462712H01	Slide plate	1
903	MF 70E0 470	ZM00046	Slide plate complete	1
49	M9 1102 004	W467880H01	Screw (for Fig. 50) 11/64(40) x 10	3
50	MF 70A0 830	W343906H01	Face plate	1
51	MF 20A1 691	W470264H01	Gasket (for Fig. 50)	1

THREAD TAKE-UP LEVER & ARM SHAFT MECHANISM

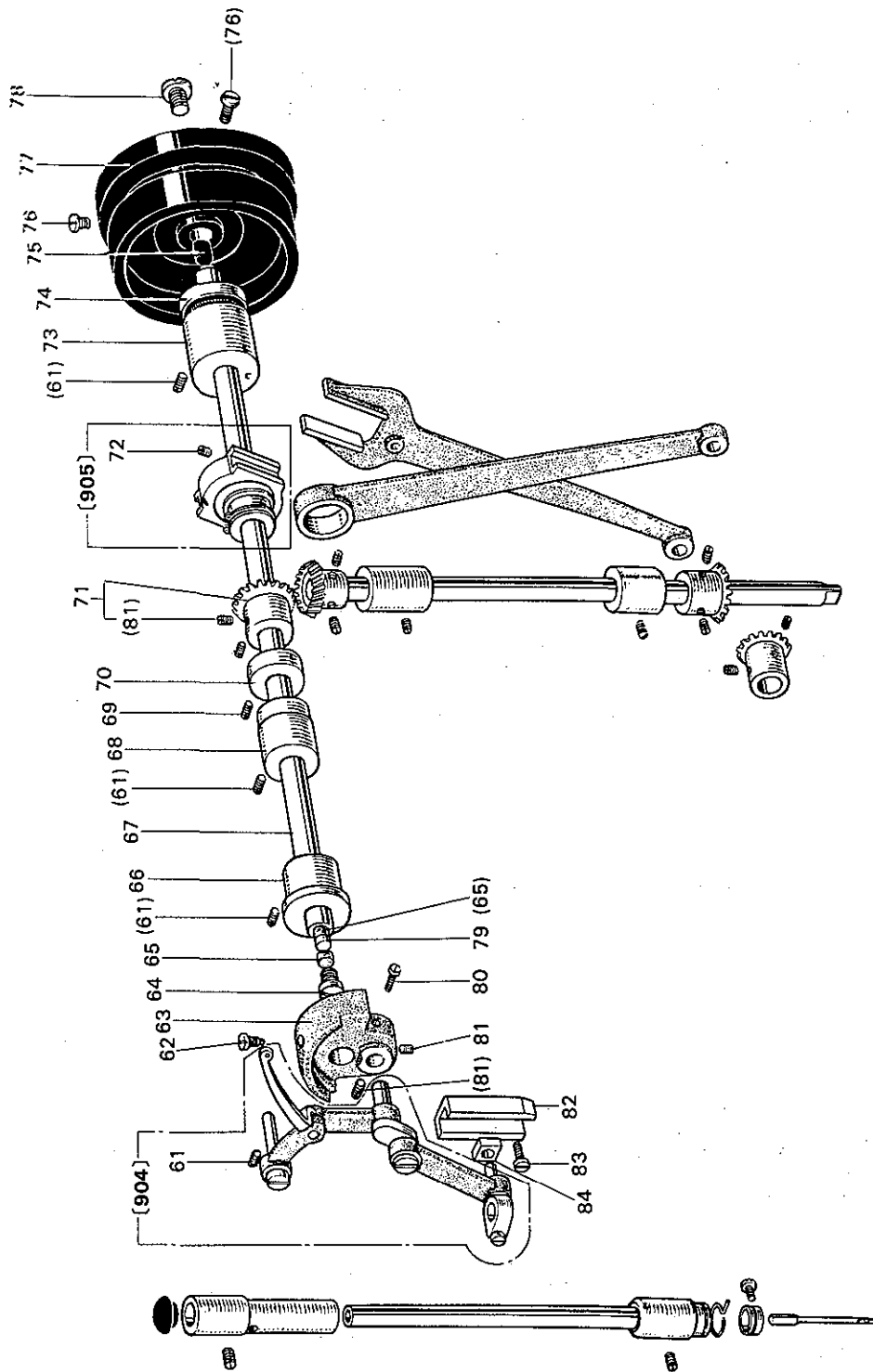

THREAD TAKE-UP LEVER & ARM SHAFT MECHANISM

Fig. No.	Parts No.	Ref. No.	Description	Amt. Req.
904	MF 10E0 580	W324586G01	Thread take-up lever complete	1
61	M9 1516 001	W500006H01	Set screw (for Fig. 904) 15/64(28) x 15	4
62	M9 1802 006	B503851H01	Set screw (for Fig. 63) 9/32(28) x 14	1
63	MF 70A0 383	W481447H01	Crank	1
64	M9 2001 011	W502474H01	Screw for arm shaft front 5/16(28) x 7	1
65	MF 10A2 740	W500003H01	Felt for arm shaft front	3
66	MF 70A0 232	W481453H01	Arm shaft bushing (left)	1
67	MF 70A0 230	W341641H01	Arm shaft	1
68	MF 70A0 234	W481452H01	Arm shaft bushing (middle)	1
69	M9 1602 001	W500036H01	Set screw (for Fig. 70) 1/4(40) x 4	2
70	MF 70A0 352	W476422H01	Arm shaft collar	3
71	MF 10A0 331	P611003X01	Bevel gear (arm shaft)	1
72	M9 1508 001	B509088H01	Set screw (for Fig. 905) 15/64(28) x 8	2
905	MF 70E0 280	W481451G01	Feed cam complete	1
73	MF 70A0 233	W481413H01	Arm shaft bushing (right)	1
74	M9 1473 086	W481476H01	Oil seal for arm shaft right	1
75	M9 0740 080	W478175H01	Rubber plug for arm shaft right	1
76	M9 1502 002	W500509H01	Set screw (for Fig. 77) 15/64(28) x 12	4
77	MF 10A0 682	W453500H01	Balance wheel	1
78	M9 2201 003	W461726H01	Screw (for Fig. 67) 11/32(28) x 10	1
79	MF 10A0 500	W501905H01	Alumi-plug for arm shaft front	1
80	M9 1801 002	W500306H01	Set screw (for Fig. 63) 9/32(28) x 13	1
81	M9 1606 001	P911000X01	Set screw (for Fig. 63) 1/4(40) x 7	4
82	MF 10A0 662	W444056H01	Needle bar connecting link guide	1
83	M9 1110 002	W500294H01	Screw (for Fig. 82) 11/64(40) x 8	2
84	MF 10A0 325	W443934H01	Square block (for Fig. 904)	1

NEEDLE BAR & VERTICAL SHAFT MECHANISM

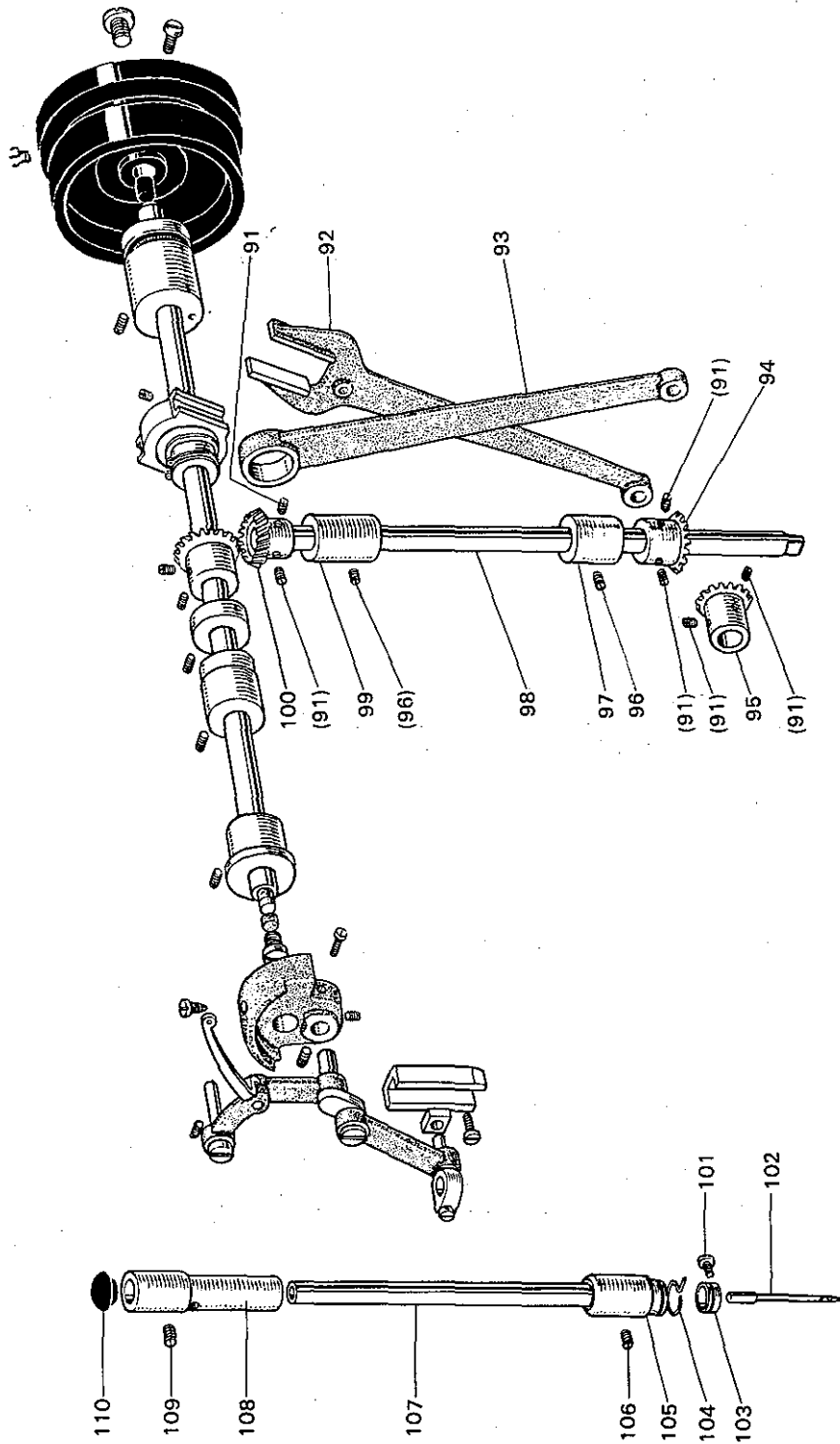

NEEDLE BAR & VERTICAL SHAFT MECHANISM

Fig. No.	Parts No.	Ref. No.	Description	Amt. Req.
91	M9 1606 001	P911000X01	Set screw (for Fig. 97) 1/4(40) x 7	6
92	MF 10A0 744	W320448H01	Feed forked connecting rod	1
93	MF 70A0 384	W450961H01	Crank rod (feed lifting rock)	1
94	MF 10A0 334	P611001X01	Bevel gear (vertical shaft lower)	1
95	MF 10A0 332	P611002X01	Bevel gear (hook shaft)	1
96	M9 1508 001	B509088H01	Set screw (for Fig. 97) 15/64(28) x 8	2
97	MF 70A0 522	W481418H02	Vertical shaft bushing (lower)	1
98	MF 70A0 520	W481437H01	Vertical shaft	1
99	MF 70A0 521	W481418H01	Vertical shaft bushing (upper)	1
100	MF 10A0 333	P611000X01	Bevel gear (vertical shaft upper)	1
101	M9 0802 003	W502074H01	Needle clamp screw 1/8(44) x 4.5	1
102	MF 70A0 128	S970010H01	Needle (DB x 1-2-14)	1
103	MF 10A2 181	W502075H01	Needle bar thread guide	1
104	MF 10A1 181	W502073H01	Needle bar bushing thread guide	1
105	MF 10A0 664	W450055H01	Needle bar bushing (lower)	1
106	M9 1102 001	W500489H01	Set screw (for Fig. 105) 11/64(40) x 2.7	1
107	MF 10A0 660	W450053H01	Needle bar	1
108	MF 70A0 663	W481449H01	Needle bar bushing (upper)	1
109	M9 1503 001	B508971H01	Set screw (for Fig. 108) 15/64(28) x 4.5	1
110	M9 0880 080	W501320H01	Rubber plug 8.8φ (for Fig. 108)	1

STITCH LENGTH REGULATOR MECHANISM

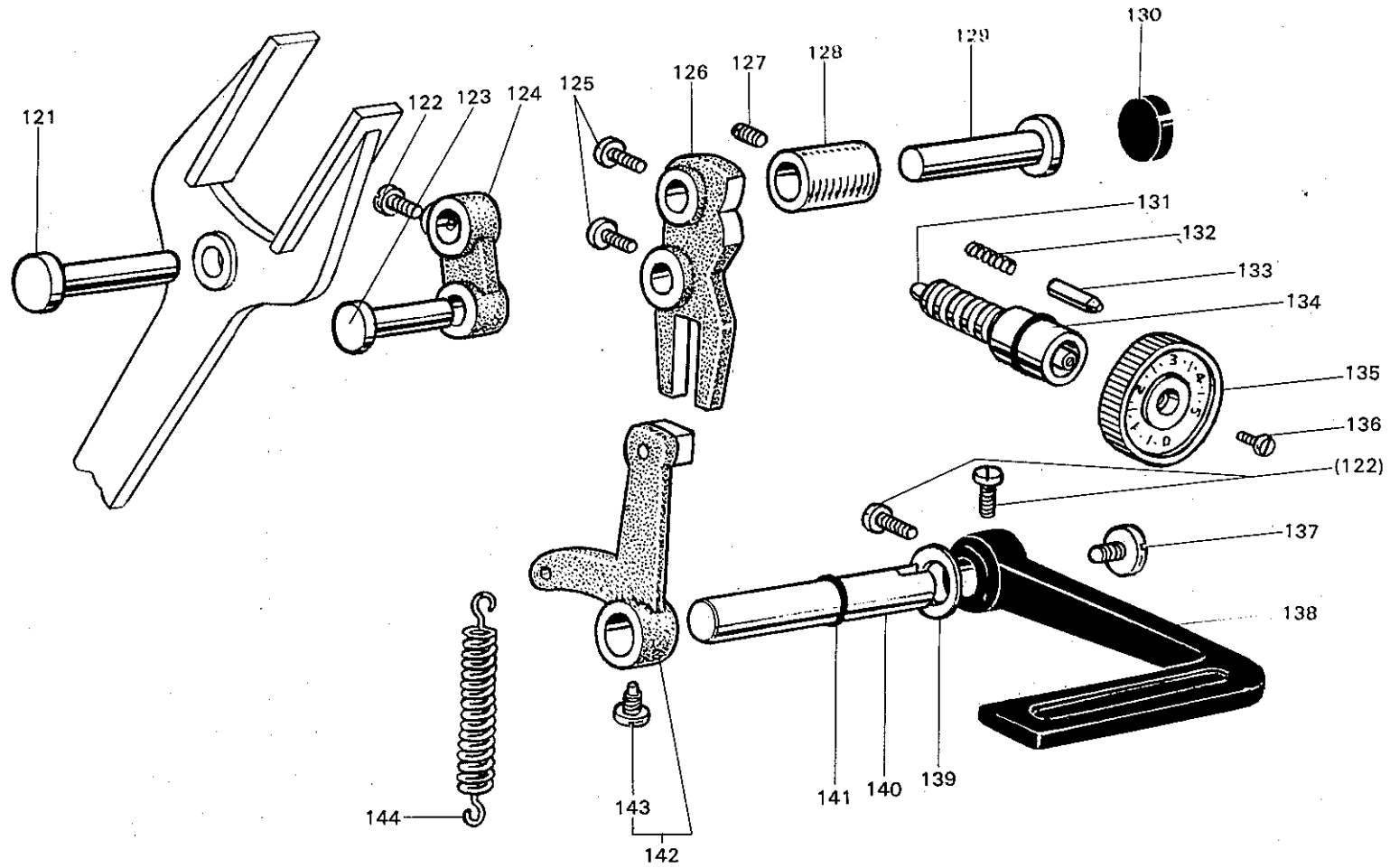

STITCH LENGTH REGULATOR MECHANISM

Fig. No.	Parts No.	Ref. No.	Description	Amt. Req.
121	M9 0718 063	W481425H01	Set pin (for Fig. 92) 7.2 ϕ x 19	1
122	M9 1501 002	W502945H01	Set screw (for Fig. 121) 15/64(28) x 8.5	3
123	M9 0905 063	W501377H01	Set pin (for Fig. 124)	1
124	MF 70A0 153	W481677H01	Feed connecting link	1
125	M9 1504 002	B508963H01	Set screw (for Fig. 126) 15/64(28) x 10	2
126	MF 10A0 152	W447221H01	Feed regulator	1
127	M9 1513 001	B509060H01	Set screw (for Fig. 128) 15/64(28) x 11	1
128	MF 70A0 750	W479396H02	Feed regulator bushing	1
129	M9 0904 063	W479395H01	Set pin (for Fig. 126)	1
130	M9 2001 080	W479394H01	Rubber plug (for Fig. 129) 20 ϕ	1
131	MF 10A0 640	W447227H01	Screw bar	1
132	MF 10A2 572	B509164H01	Spring (for Fig. 133)	1
133	MF 10A0 852	B419163H01	Stopper pin (for Fig. 135)	1
134	M9 1000 085	S648001H06	O-ring (for Fig. 131) P10	1
135	MF 11D0 631	W331486H01	Stitch length regulator dial (0-4)	1
136	M9 1209 002	B503887H01	Screw (for Fig. 135) 3/16(28) x 8	1
137	M9 1207 003	B509288H01	Screw (for Fig. 138) 3/16(28) x 6.5	1
138	MF 26B0 632	W465387H01	Reverse sewing lever	1
139	M9 5003 053	B503895H01	Spring washer (for Fig. 138)	1
140	MF 10A0 633	W450088H01	Shaft (for Fig. 138)	1
141	M9 0600 085	S648001H01	O-ring (for Fig. 140) P6	1
142	MF 10E0 635	W462614G01	Reverse sewing crank	1
143	M9 1501 007	B509256H01	Set screw (for Fig. 142)	1
144	MF 10A0 572	W447225H01	Spring (for Fig. 142)	1

PRESSER FOOT MECHANISM

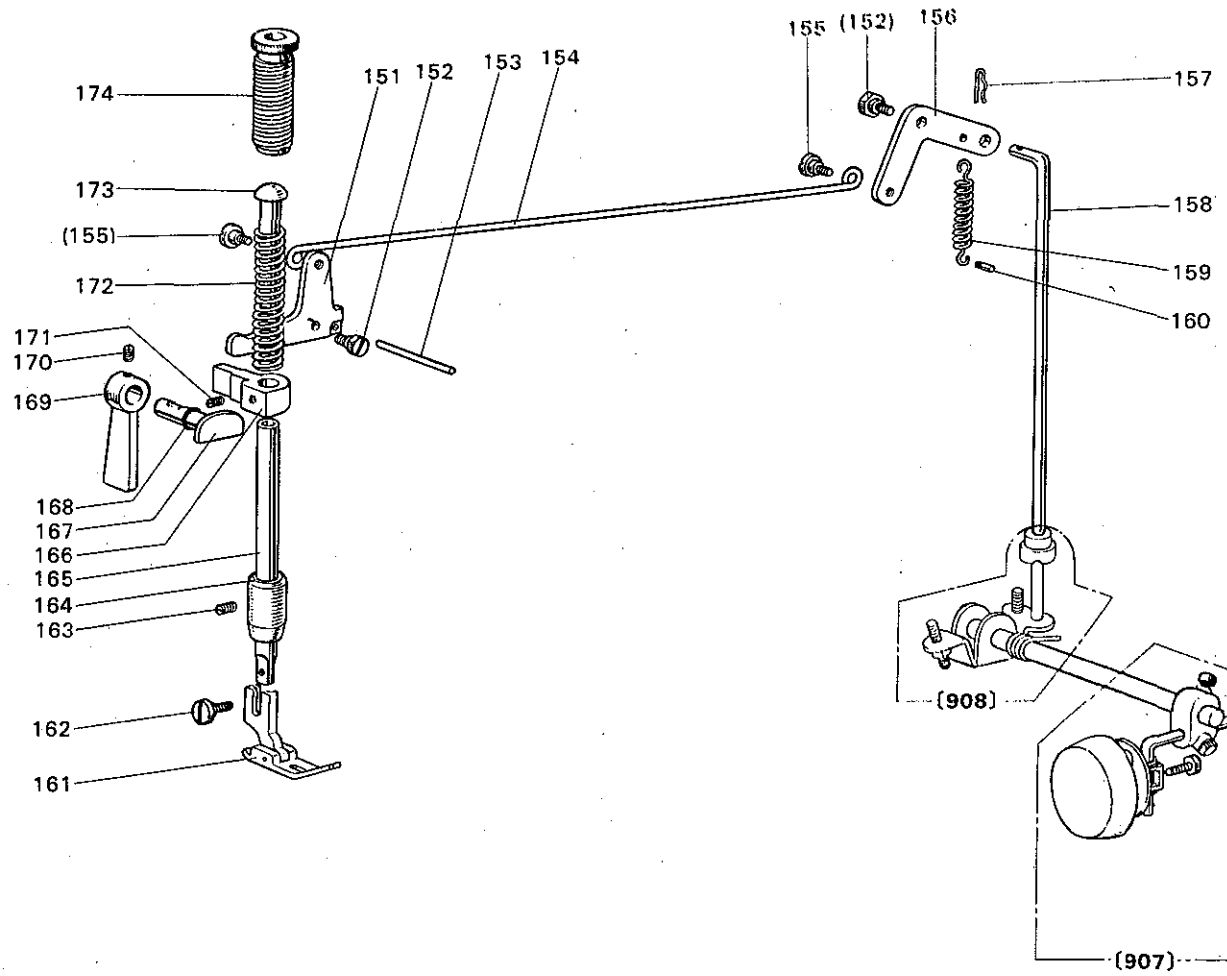

PRESSER FOOT MECHANISM

Fig. No.	Parts No.	Ref. No.	Description	Amt. Req.
151	MF 70A0 950	W481457H01	Knee lifter lever (left)	1
152	M9 1503 031	W481459H01	Bolt (for Fig. 151)	2
153	M9 0314 060	W481434H01	Tension releasing pin	1
154	MF 70A0 738	W481477H01	Knee lifter rod	1
155	M9 1219 015	W481460H01	Screw (for Fig. 154) 3/16(28) x 6.7	2
156	MF 70A1 950	W481458H01	Knee lifter lever (right)	1
157	M9 0102 062	P587009X01	Snap pin (for Fig. 158)	1
158	MF 70A0 511	W481456H01	Knee lifter rod connecting rod	1
159	MF 70A0 571	W481478H01	Spring (for Fig. 156)	1
160	M9 0506 060	P587011X01	Pin (for Fig. 159)	1
161	MF 21D0 105	W472730G01	Presser foot	1
162	M9 0922 002	W464016H01	Screw (for Fig. 16) 9/64(40) x 8	1
163	M9 1102 001	W500489H01	Set screw (for Fig. 164) 11/64(40) x 2.7	1
164	MF 10A0 267	W502081H01	Presser bar bushing	1
165	MF 10A0 262	W502079H01	Presser bar	1
166	MF 70A0 265	W481461H01	Presser bar lifting bracket	1
167	MF 70A0 253	W481455H01	Presser bar lifting cam	1
168	M9 0800 086	P625001X01	O-ring (for Fig. 167)	1
169	MF 70A0 252	W481454H01	Presser bar lifter	1
170	M9 1108 001	B503846H01	Set screw (for Fig. 169) 11/64(40) x 5.5	1
171	M9 1508 001	B509088H01	Set screw (for Fig. 165) 15/64(28) x 8	1
172	MF 10A0 259	W502444H01	Presser spring	1
173	MF 20A0 703	W475491H01	Presser bar guide	1
174	M9 3209 035	W481436H01	Presser regulating thumb screw	1

FEED ROCK SHAFT & FEED LIFTING SHAFT MECHANISM

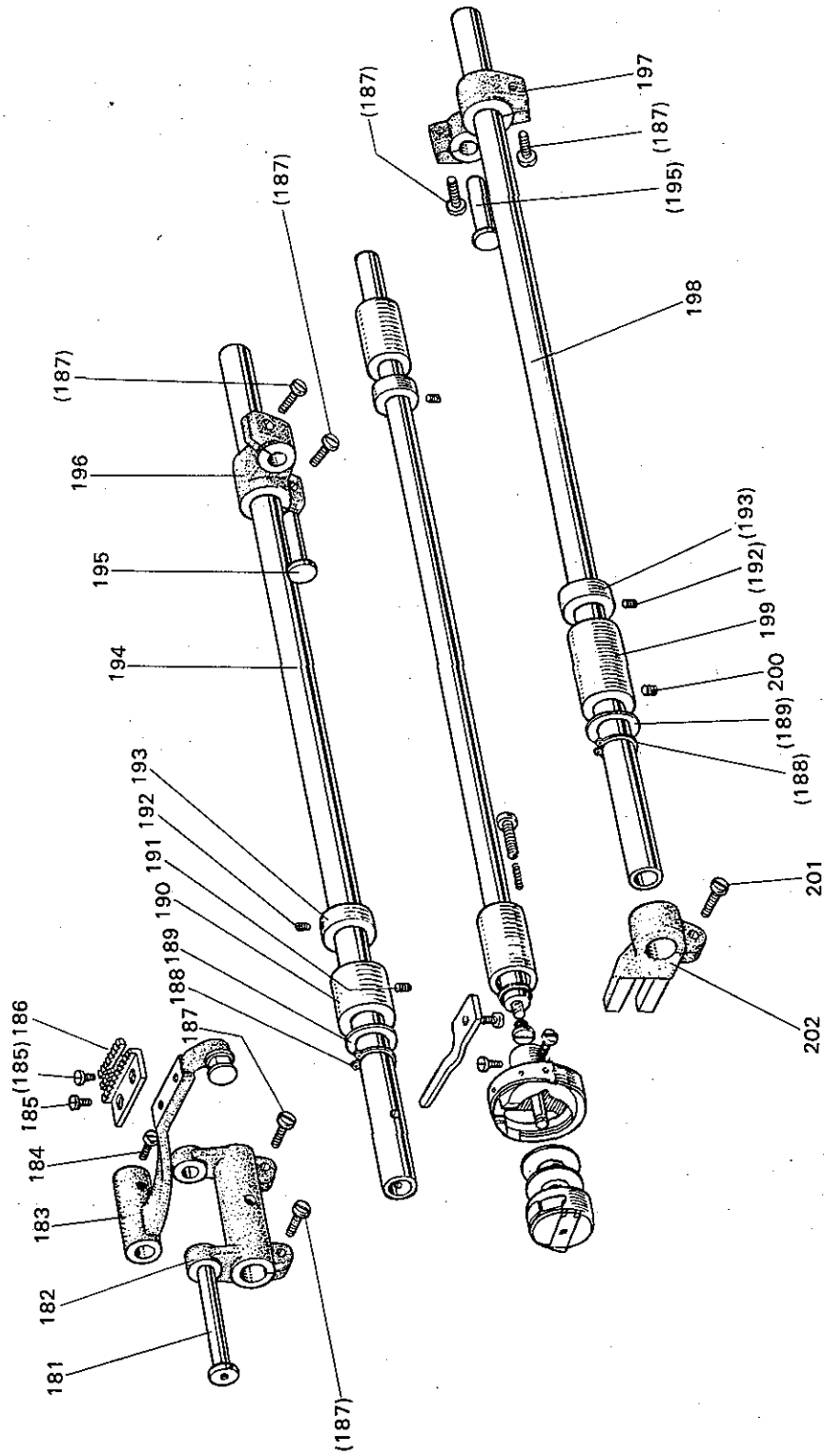

FEED ROCK SHAFT & FEED LIFTING SHAFT MECHANISM

FEED ROCK SHAFT & FEED LIFTING SHAFT MECHANISM

Fig. No.	Parts No.	Ref. No.	Description	Amt. Req.
181	MF 70A0 283	W481422H01	Feed bar shaft	1
182	MF 70A0 278	W481421H01	Feed rock shaft crank (left)	1
183	MF 70A0 281	W481466H01	Feed bar	1
184	M9 1103 002	B509062H01	Set screw (for Fig. 183) 11/64(40) x 5	1
185	M9 0806 002	B508857H01	Screw (for Fig. 186) 1/8(44) x 6	2
186	MF 11D0 104	W457555H01	Feed dog (22 T.P.I)	1
	MF 11D1 104	W467237H01	Feed dog (16 T.P.I)	1
187	M9 1203 002	B509178H01	Screw (for Fig. 182) 3/16(28) x 15	6
188	M9 0315 065	S591411H15	C-type stop ring (for Fig. 194, 198)	2
189	M9 3001 052	W502467H01	Slide washer (for Fig. 194, 198)	2
190	MF 70A0 286	W481663H01	Feed rock shaft bushing (left)	1
191	M9 1503 001	B508971H01	Set screw (for Fig. 190) 15/64(28) x 4.5	1
192	M9 1602 001	W500036H01	Set screw (for Fig. 193) 1/4(40) x 4	4
193	MF 70A0 352	W476422H01	Collar (for Fig. 194, 198)	2
194	MF 70A0 491	W481420H01	Feed rock shaft	1
195	M9 0904 060	W502476H02	Set pin for feed forked connecting rod	2
196	MF 70A0 279	W481473H01	Feed rock shaft crank (right)	1
197	MF 70A0 277	W481472H01	Feed lifting rock shaft crank (right)	1
198	MF 70A0 460	W481673H01	Feed lifting rock shaft	1
199	MF 70A1 286	W481475H01	Feed lifting rock shaft bushing (left)	1
200	M9 1516 001	W500006H01	Set screw (for Fig. 199) 15/64(28) x 15	1
201	M9 1112 002	B501889H01	Screw (for Fig. 202) 11/64(40) x 12	1
202	MF 70A0 276	W481471H01	Feed lifting rock shaft forked crank	1

ROTATING HOOK SHAFT & ROTATING HOOK MECHANISM

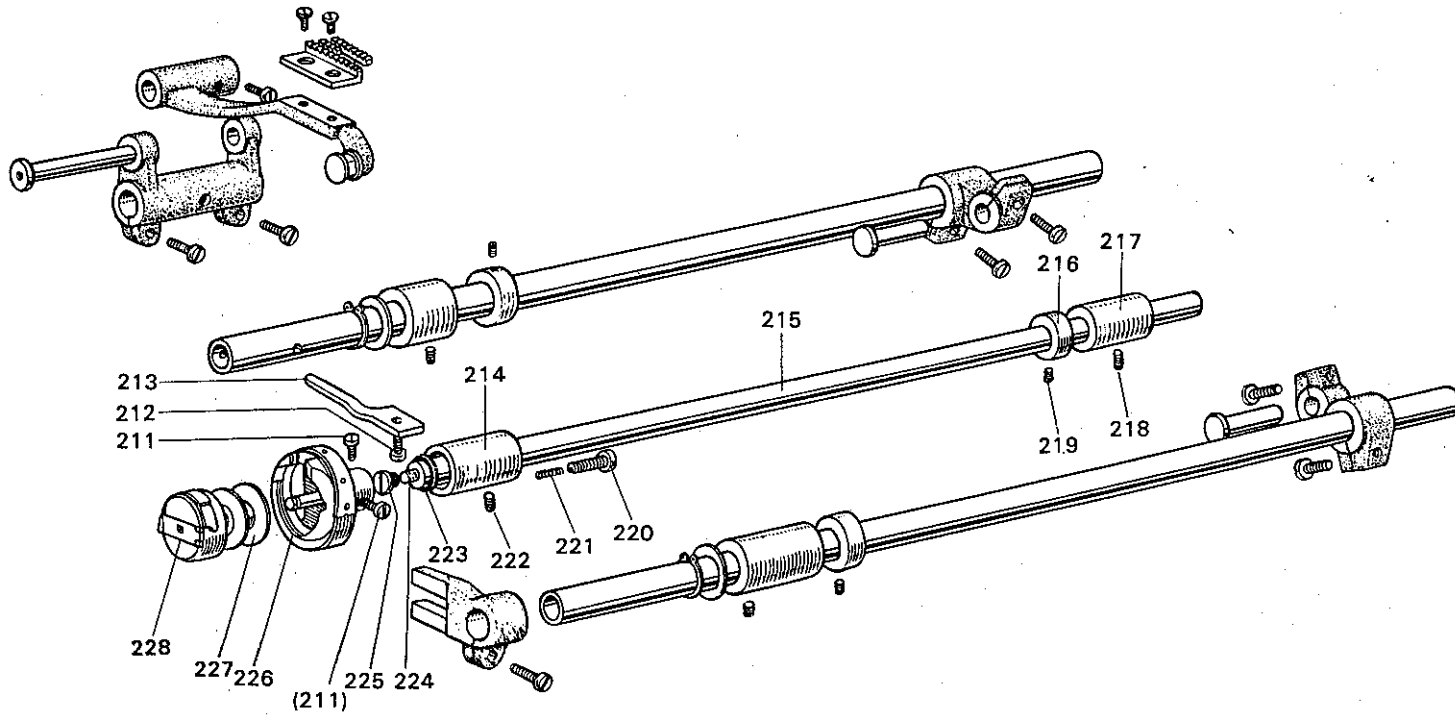

ROTATING HOOK SHAFT & ROTATING HOOK MECHANISM

Fig. No.	Parts No.	Ref. No.	Description	Amt. Req.
211	M9 1101 002	W500194H01	Set screw (for Fig. 226) 11/64(40) x 14	2
212	M9 1118 002	B509061H01	Screw (for Fig. 213) 11/64(40) x 10	1
213	MF 20A0 229	W468837H01	Rotating hook positioner	1
214	MF 70A0 451	W481463H01	Rotating hook shaft bushing (left)	1
215	MF 70A0 450	W481462H01	Rotating hook shaft	1
216	MF 10A0 352	B422844H01	Collar (for Fig. 215)	1
217	MF 70A0 452	W481419H01	Rotating hook shaft bushing (right)	1
218	MF 1516 001	W500006H01	Set screw (for Fig. 217) 15/64(28) x 15	1
219	M9 1503 001	B508971H01	Set screw (for Fig. 216) 15/64(28) x 4.5	2
220	M9 0909 030	W481464H01	Oil adjusting screw 9/64(40) x 15	1
221	MF 70A1 572	W481664H01	Spring (for Fig. 220)	1
222	M9 1513 001	B509060H01	Set screw (for Fig. 214) 15/64(28) x 11	1
223	M9 0802 086	W468257H01	Oil seal for rotating hook shaft	1
224	MF 10E3 148	W500231H01	Oil cotton braid (for Fig. 215)	1
225	M9 1251 030	W500190H01	Special screw (for Fig. 215) 3/16(32) x 6.7	1
226	MF 10A0 120	HSL-BS(J)	Rotating hook	1
227	MF 10A0 123	W462632H01	Bobbin	1
228	MF 10E0 125	W461742G01	Bobbin case	1

LUBRICATION MECHANISM

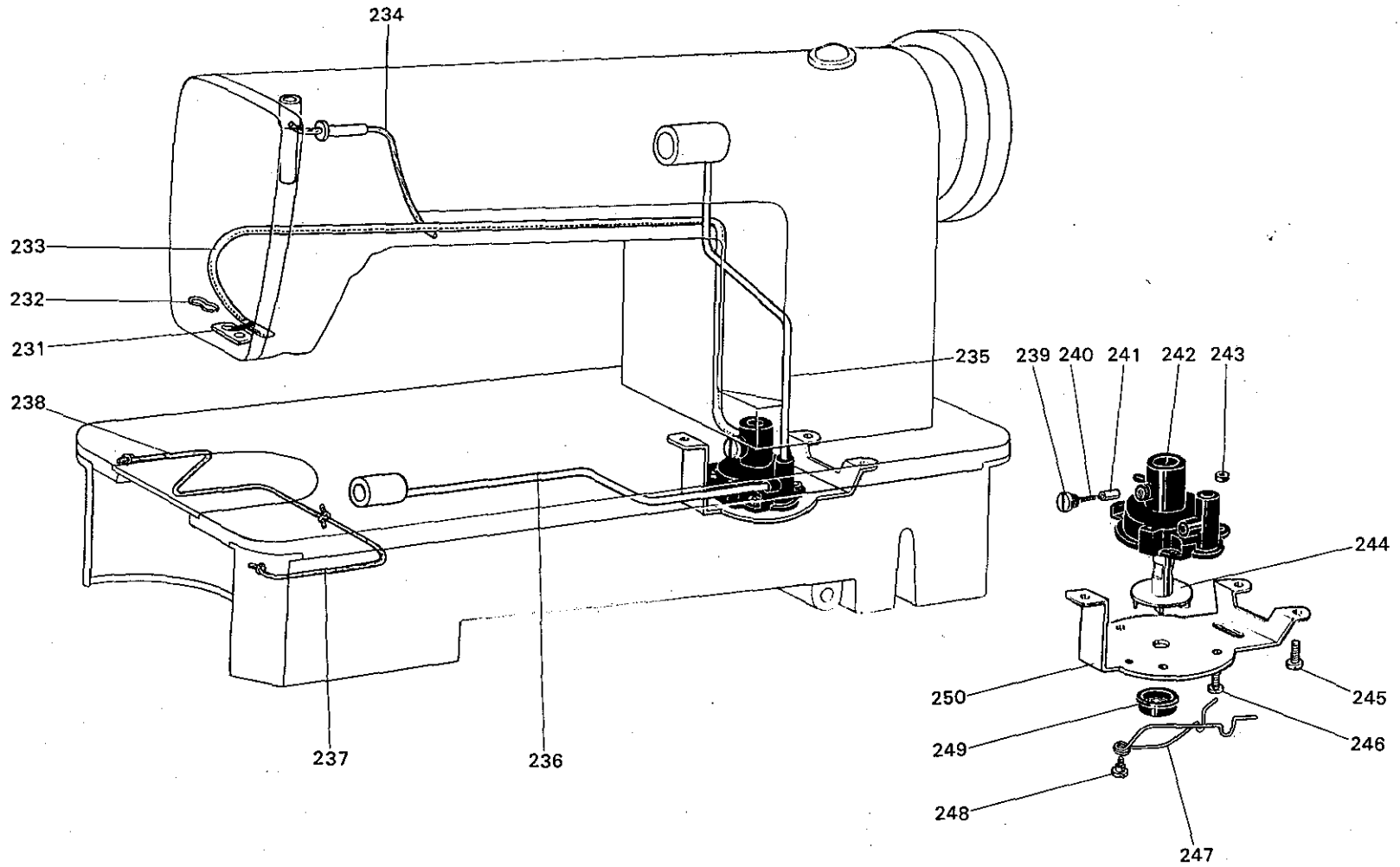

LUBRICATION MECHANISM

Fig. No.	Parts No.	Ref. No.	Description	Amt. Req.
231	MF 70E0 740	W482321G01	Felt pouch (return oil filter)	1
232	MF 70A0 605	W479329H01	Felt pouch supporter	1
233	MF 70A0 731	W482323H01	Oil return pipe	1
234	MF 10E2 148	W444138H01	Oil cotton braid (for Fig. 904, 108 oiling)	1
235	MF 70A0 688	W341645H01	Oil pipe for arm shaft	1
236	MF 70A1 688	W341646H01	Oil pipe for rotating hook shaft	1
237	MF 10E2 148	W444138H01	Oil cotton braid for feed lifting mecha.	1
238	MF 10E2 148	W462982H01	Oil cotton braid for feed rock mecha.	1
239	M9 1601 002	W501102H01	Oil adjusting screw 1/4(40) x 5	1
240	MF 70A2 572	W481441H01	Spring (for Fig. 241)	1
241	MF 70A0 753	W481440H01	Plunger for oil pump	1
242	MF 70A0 783	W341644H01	Oil pump (body)	1
243	M9 1002 045	S541121H02	Nut (for Fig. 246) M4 x 3.2	3
244	MF 70A0 685	W481435H01	Oil pump impeller	1
245	M9 1103 004	W467868H01	Screw (for Fig. 250) 11/64(40) x 13	3
246	M9 0410 037	S512131H01	Screw (for Fig. 242) M4 x 10	3
247	MF 70A1 605	W481442H01	Oil pump screen set spring	1
248	M9 1219 015	W481460H01	Screw (for Fig. 247) 3/16(28) x 6.7	1
249	MF 70E0 337	W481445G01	Oil pump screen	1
250	MF 70A0 601	W341680H01	Oil pump fitting plate	1

ACCESSORY BOX & ITS ACCESSORIES

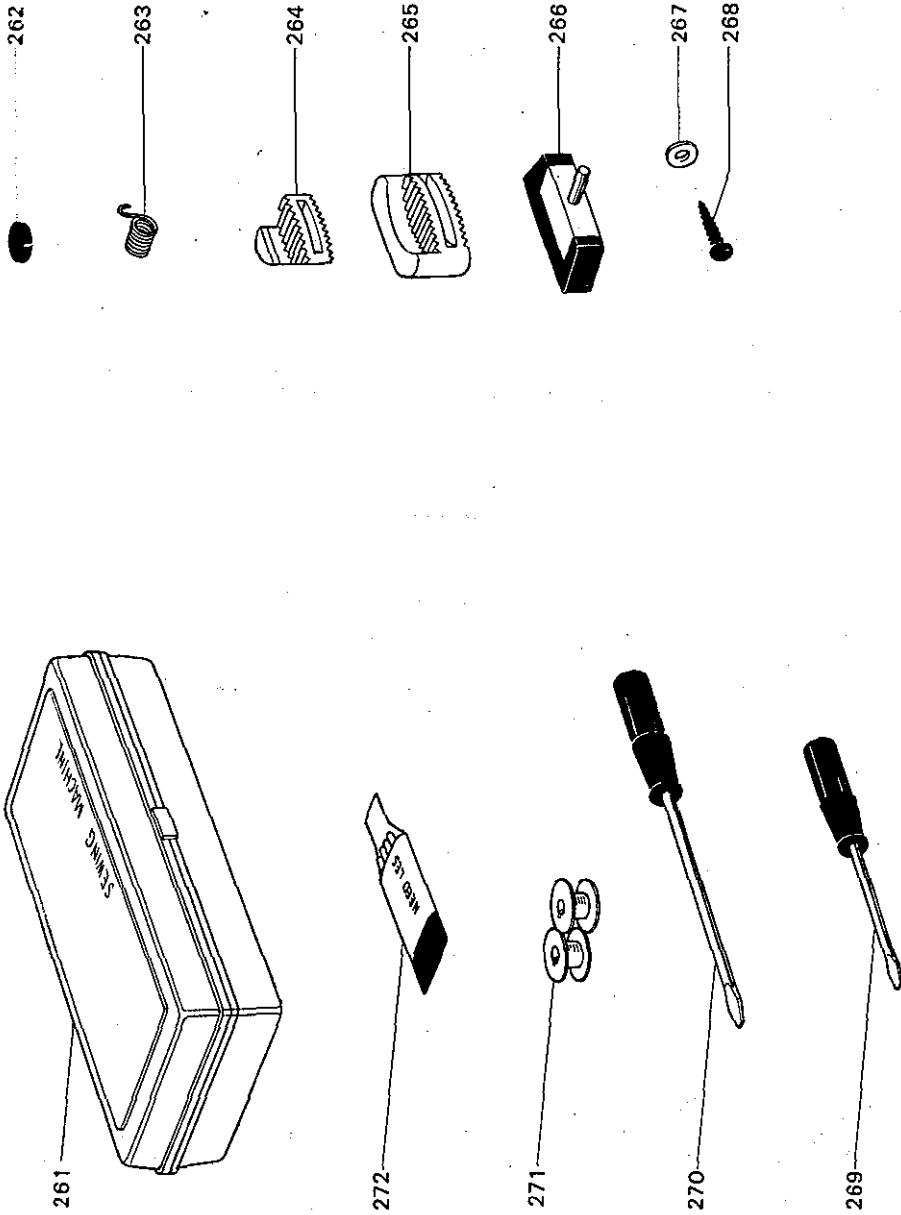

ACCESSORY BOX & ITS ACCESSORIES

Fig. No.	Parts No.	Ref. No.	Description	Amt. Req.
261	MF 10A0 749	W461776H01	Accessory box	1
262	M9 0701 099	P463000X01	Magnet block for oil reservoir	1
263	MF 10A0 187	W475488H01	Thread take-up spring	1
264	MF 70A1 419	W476426H02	Vibration preventing rubber (small)	2
265	MF 70A0 419	W476425H02	Vibration preventing rubber (large)	2
266	MF 70E0 418	W481678G02	Table hinge with rubber cushion	2
267	M9 0608 050	S562131H04	Washer for bobbin winder	2
268	M9 0401 041	S519132H01	Screw for bobbin winder	2
269	MB 02A1 608	P842002X01	Screw driver (small)	1
270	MB 02A0 608	P842003X01	Screw driver (middle)	1
271	MF 10A0 123	W462632H01	Bobbin	4
272	MF 70A0 128	S970010H01	Needle DBx 1-2-14	4

OIL RESERVOIR & OTHER ACCESSORIES

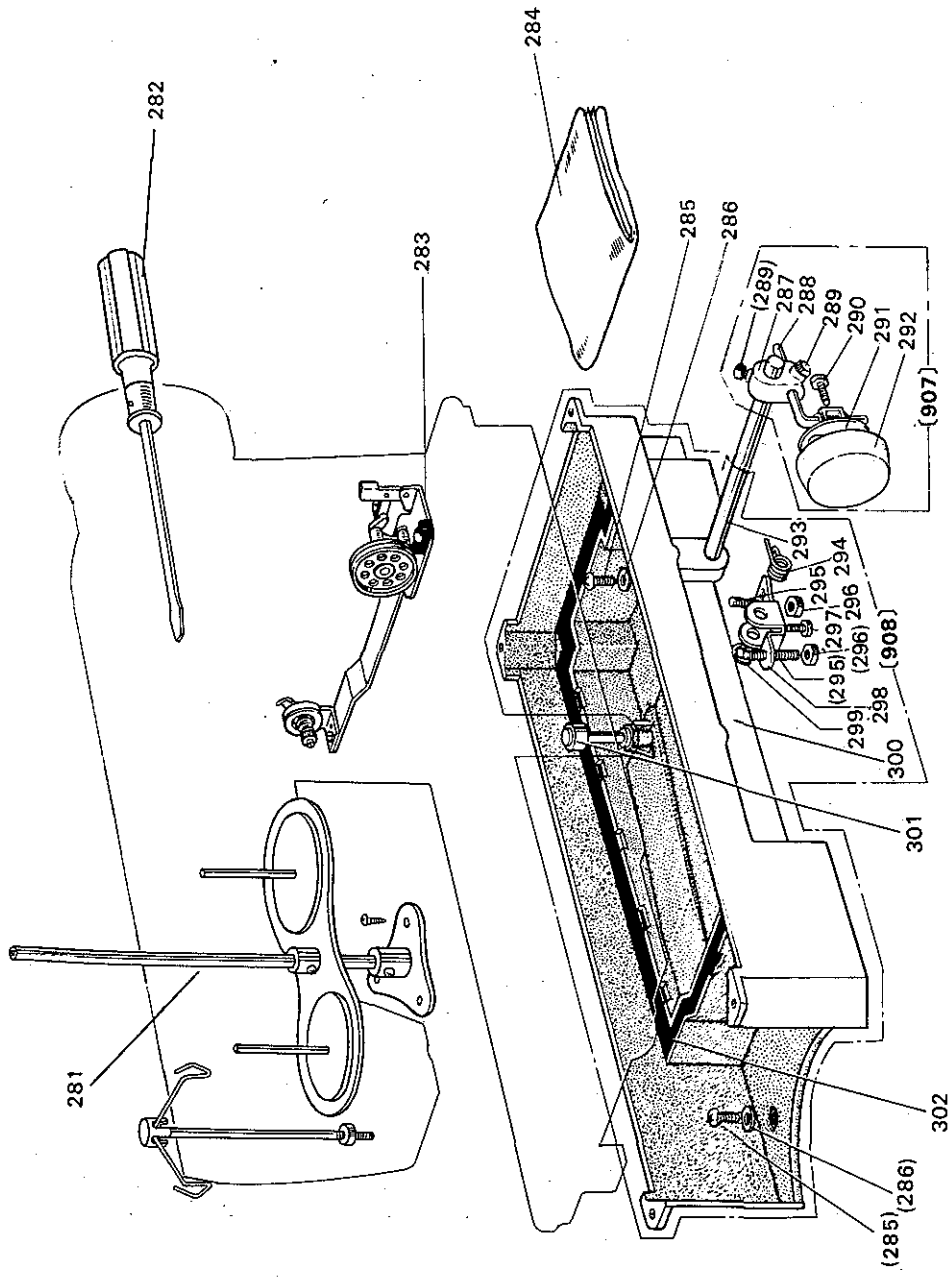

OIL RESERVOIR & OTHER ACCESSORIES

Fig. No.	Parts No.	Ref. No.	Description	Amt. Req.
281	MF 10E2 193	P995002X01	Cotton stand complete	1
282	MF 60A0 608	W319408H01	Screw driver (large)	1
283	MF 20E0 190	P992002X01	Bobbin winder complete	1
284	MF 10A0 734	W220641H01	Vinyl cover	1
285	M9 2001 004	W478196H01	Oil drain screw 5/16(28) x 10.0	2
286	M9 7001 052	W470200H01	Washer (for Fig. 286)	2
287	MF 40A0 784	P659022X02	Knee plate bar bracket (with screw)	1
288	MF 20A0 728	W449371H01	Knee plate bar	1
289	M9 2001 031	B509174H01	Set screw (for Fig. 288) 5/16(18) x 13	2
290	M9 1553 022	P993003X01	Set screw (for Fig. 293) M6 x 10	1
291	MF 40A0 737	P993000X01	Knee plate	1
292	MF 40A1 737	W482356H01	Pad for knee plate	1
907	MF 40E0 727	W341682G04	Knee lifter complete	1
293	MF 20A1 723	W478169H01	Knee lifter rock shaft	1
294	MF 20A1 729	W479331H01	Spring (for Fig. 299)	1
295	M9 1520 001	B503980H01	Stopper screw (for Fig. 907) 15/64(28) x 28	2
296	M9 1501 045	B509260H01	Nut (for Fig. 296) 15/64(28)	2
297	M9 1502 002	W500509H01	Set screw (for Fig. 299) 15/64(28) x 12	1
298	MF 20A1 724	W477606H01	Knee lifter crank	1
299	M9 0509 065	S592411H08	E-type stop ring	1
300	MF 70A0 139	P997000X02	Oil reservoir	1
908	MF 70E0 139	W341681G01	Oil reservoir complete	1
301	MF 70A0 578	W481685H01	Knee lifter lifting rod	1
302	MF 20A2 691	W471440H02	Gasket for oil reservoir (small)	1
	MF 20A3 691	W471441H02	Gasket for oil reservoir (large)	1

SEWING PARTS FOR MODELS N430-2 & N430-3

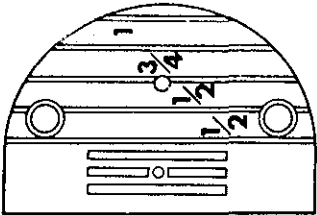
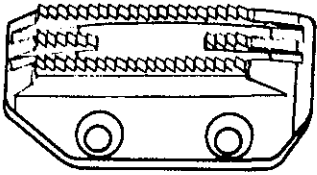
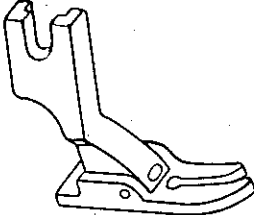
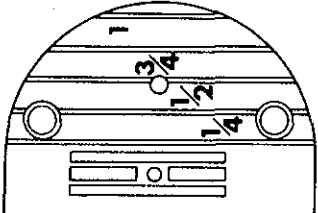
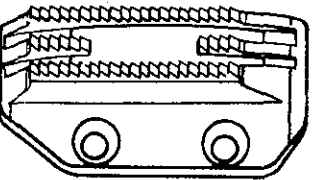
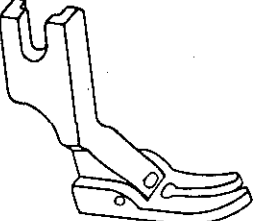
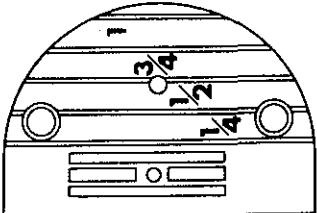
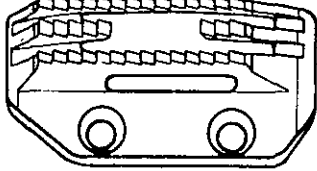
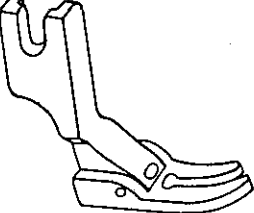
Specification	Needle Plate	Feed Dog	Presser Foot
<p>Regular parts for Model N430-2, for light to medium material.</p>	 <p>MF 20A0 101 (W326216H01)</p>	 <p>MF 20A0 104 (W453578H01) (22 T.P.I)</p>	 <p>MF 10A0 105 (W450580G01)</p>
<p>Chaining-off parts for Model N430-2, for light to medium material.</p>	 <p>MF 11D1 101 (W328830H01)</p>	 <p>MF 11D0 104 (W457555H01) (22 T.P.I)</p>	 <p>MF 21D0 105 (W472730G01)</p>
<p>Chaining-off parts for Model N430-3, for medium to heavy material.</p>	 <p>MF 11D1 101 (W328830H01)</p>	 <p>MF 11D1 104 (W467237H01) (16 T.P.I)</p>	 <p>MF 21D0 105 (W472730G01)</p>

