



INDUSTRIAL SEWING MACHINE

MODEL

PLK-G-PAL

TECHNICAL MANUAL

Operation Panel

| | |
|---|--------|
| [1] For safe use | [1]-1 |
| [2] Precautions for use | [2]-1 |
| [3] Explanations of basic screen, icons and operation | [3]-1 |
| 1.Screen configuration | [3]-1 |
| 2.Explanations of Standard screen 1 | [3]-2 |
| 3.Explanations of Standard screen 2 | [3]-3 |
| 4.The Up Counter screen is explained below | [3]-3 |
| 5.The Bobbin Winding screen is explained below | [3]-4 |
| 6.Explanations of basic icons | [3]-4 |
| 7.Explanation of operations | [3]-5 |
| 8.Adjusting the Liquid Crystal Contrast | [3]-6 |
| [4] Sewing Data Compatibility | [4]-1 |
| [5] Reading, writing and erasing data | [5]-1 |
| 1.USB | [5]-1 |
| 2.Reading | [5]-2 |
| 3.Writing | [5]-5 |
| 4.Erasing..... | [5]-6 |
| 5.Reading data with shortcut icons (Reading from internal memory) | [5]-7 |
| 6.Rename the data number | [5]-8 |
| [6] Creating stitching data | [6]-1 |
| 1.Flow of data creation..... | [6]-1 |
| 2.Description of arrow input screen..... | [6]-4 |
| 3.Description of menu | [6]-5 |
| 4.Skip jogging | [6]-6 |
| [7] Methods of creating sewing data | [7]-1 |
| 1.Linear input | [7]-1 |
| 2.Arc input..... | [7]-4 |
| 3.Circle input..... | [7]-8 |
| 4.Curve input..... | [7]-11 |
| 5.Broken line input | [7]-15 |
| 6.Point input..... | [7]-18 |
| 7.Code data input..... | [7]-20 |
| 8.Back tacking (start/end back tacking) | [7]-25 |
| 9.Back tacking (overlap back tacking)..... | [7]-27 |
| 10.Multiple stitching..... | [7]-29 |
| 11.Offset stitching (with overlap back tacking) | [7]-32 |
| 12.Zigzag stitching (with overlap back tacking) | [7]-34 |
| [8] Controlling the Presser Foot | [8]-1 |
| [9] Table of stitching type combinations | [9]-1 |
| [10] Call-up function | [10]-1 |

| | |
|---|---------|
| [11] Modification mode | [11]-1 |
| 1.Main modification mode functions | [11]-1 |
| 2.Entering the modification mode..... | [11]-1 |
| 3.Quitting the modification mode..... | [11]-2 |
| 4.Changing the feed data to home position..... | [11]-2 |
| 5.Confirming on the image screen | [11]-3 |
| 6.Modifying the stitching start position | [11]-5 |
| 7.Deleting a stitch (Deleting the designated No. of stitches) | [11]-7 |
| 8.Deleting a stitch (Deleting all stitches after the designated position) | [11]-9 |
| 9.Adding a stitch (Adding one stitch)..... | [11]-11 |
| 10.Adding a stitch (Adding the same stitch) | [11]-13 |
| 11.Modifying the stitch position (Position of subsequent data fixed)..... | [11]-15 |
| 12.Modifying the stitch position (Subsequent data position moved) | [11]-17 |
| 13.Moving a block (Changing the prior/subsequent data) | [11]-19 |
| 14.Moving a block (Adding new data to the prior/subsequent data) | [11]-21 |
| 15.Modifying a block 1 (Linear input) | [11]-23 |
| 16.Modifying a block 2 (Broken line, arc, curve input) | [11]-26 |
| 17.Modifying a block 3 (Zigzag input)..... | [11]-32 |
| 18.Modifying a block 4 (Changing the feed data) | [11]-34 |
| 19.Modifying stitch length (Designated distance modification) | [11]-39 |
| 20.Modifying stitch length (All After designated stitch) | [11]-41 |
| 21.Modifying material step | [11]-43 |
| 22.Modifying the stitching speed (All sections after designated position) | [11]-46 |
| 23.Modifying the stitching speed (N stitches after designated position) | [11]-48 |
| 24.Modifying code data (Adding code data) | [11]-50 |
| 25.Modifying code data (Deleting code data) | [11]-52 |
| | |
| [12] Data conversion mode | [12]-1 |
| 1.Main data conversion mode functions | [12]-1 |
| 2.Entering the conversion mode..... | [12]-1 |
| 3.Quitting the conversion mode..... | [12]-2 |
| 4.Confirming on the image screen (for the conversion mode) | [12]-2 |
| 5.Back tacking(Start/end back tacking) | [12]-3 |
| 6.Back tacking(Overlap back tacking) | [12]-5 |
| 7.Zigzag stitching | [12]-7 |
| 8.Scaling | [12]-9 |
| 9.Symmetrical | [12]-12 |
| 10.Rotation | [12]-13 |
| 11.Multiple..... | [12]-15 |
| 12.Offset..... | [12]-18 |
| | |
| [13] Function mode | [13]-1 |
| 1.Outline | [13]-1 |
| 2.Explanation of each function mode | [13]-2 |
| | |
| [14] Input/Output setting mode | [14]-1 |
| 1.Outline | [14]-1 |
| 2.Explanation of input/output setting mode | [14]-2 |
| 3.Input signal setting table | [14]-6 |
| 4.Output signal setting table..... | [14]-9 |
| | |
| [15] Program mode | [15]-1 |
| 1.Setting methods..... | [15]-1 |
| 2."System, setting file write" and "Setting file read" | [15]-4 |

| | |
|---|---------|
| [16] Program mode list | [16]-1 |
| 1.Wiper | [16]-1 |
| 2.Slow start | [16]-1 |
| 3.Clamp | [16]-1 |
| 4.Area limit | [16]-4 |
| 5.Needle position | [16]-5 |
| 6.Thread breaking sensor | [16]-5 |
| 7.Home position | [16]-5 |
| 8.Halt | [16]-7 |
| 9.Counter | [16]-7 |
| 10.Brake | [16]-9 |
| 11.Presser foot | [16]-9 |
| 12.Bobbin winding | [16]-10 |
| 13.Feed method | [16]-10 |
| 14.Speed | [16]-11 |
| 15.Thread trimming/Thread release | [16]-12 |
| 16.Step | [16]-13 |
| 17.Jog | [16]-13 |
| 18.Feed angle | [16]-14 |
| 19.Other | [16]-15 |
| 20.Pattern | [16]-16 |

| | |
|---|--------|
| [17] Error / Message display | [17]-1 |
| 1.[E-***] Error code | [17]-1 |
| 2.[M-***] Message code | [17]-4 |

Thank you for purchasing the Mitsubishi industrial sewing machine PLK-G Series. Please read this technical manual before starting to ensure correct and long-term use.

- * The contents of this manual may not be reproduced in part or whole.
- * The contents of this manual are subject to change without notice.
- * An utmost effort has been made to cover all points of operation in this manual. Contact Mitsubishi if you have any questions regarding the contents.

COPYRIGHT(C)2011-2015 MITSUBISHI ELECTRIC CORPORATION

[1] For safe use

■ For safe use

Always observe the following matters to safely use the Mitsubishi industrial electronic sewing machine PLK-G Series.

Before starting

Before using this control unit, read all of the technical manuals carefully, and correctly use the unit following the manual. Also read the "Mitsubishi Industrial Sewing Machine Technical Manual <Sewing Machine Head>" for details on the general configuration and sewing machine head.

Application and purpose

This control unit is designed to drive and control the Mitsubishi industrial electronic sewing machine PLK-G Series. Do not use this control unit for other applications or purposes. Do not use this control unit until it has been confirmed that safety measures have been accurately taken for the installed electronic sewing machine head section.

Working environment

Please use this control unit in the industrial setting only. And do not use this control unit in the following type of environment.

(1) Power voltage

- * Where the voltage fluctuation exceeds $\pm 10\%$ of the rated voltage.
- * Where the specified power capacity (refer to technical manual [Control unit] page [4]-2 "5. Power capacity") cannot be ensured.

(2) Magnetic noise

- * Where strong fields or magnetic fields are generated, such as near a high-output high frequency oscillating machine or high frequency welder.

(3) Temperature and humidity

- * Where the ambient temperature is 35°C or more and 5°C or less.
- * Where the unit will be subject to direct sunlight, or outdoors.
- * Near sources of heat, such as heating appliances.
- * Where the relative humidity is 45% or less, or 85% or more, and where dew may condense.

(4) Atmosphere

- * In an atmosphere containing dust or corrosive gases, etc.
- * In a flammable gas or explosive environment.

(5) Vibration

- * If excessive vibration could occur when installed on the sewing machine, separately install the control box.

■ Installation

Control box

Correctly install the control box according to this manual.

Accessories

Always disconnect the control unit from the main power supply before installing the accessories listed in this manual. (Turn the power switch OFF, and disconnect the plug from the socket (power supply line).)

Cable

- (1) Lay the connection cables so that excessive force will not be applied during operation. Do not excessively bend the cables.
- (2) Cables laid near operating machine sections must be separated by at least 25mm.
- (3) Before connecting the power cable to the control box, confirm that the power voltage matches the specifications given on the control box's rating nameplate and factory shipment voltage nameplate. Connect the cable to the indicated positions, and then supply the power. When using a power unit, connect the cable to the power unit and supply the power. In addition, when using a power unit, confirm that the power voltage matches the specifications given on the power unit's rating nameplate. Turn the power switch OFF before making any connections.

Grounding

Always ground the power cord's grounding wire.

Enclosed units and accessories

Connect the electrical enclosed units and accessories only to the positions indicated in the manual.

Removal

- (1) Always turn the power switch OFF and disconnect the plug from the socket (power supply line) before removing the control box.
- (2) Do not pull out the cord when disconnecting the plug. Always hold the plug receptacle when disconnecting the plug.
- (3) Note that a high voltage is applied inside the control panel, **so always turn the power OFF and wait at least ten minutes before opening the control box cover.**

■ NOTICE CONCERNING CE MARKING

- (1) Electronic sewing machine PLK-G series are applied to CE conformity marking by installing the exclusive device [PLK-G-CE].
When the products are used in the EU region, these devices are necessary to be installed.
- (2) Electronic sewing machine should be use limited to the industrial areas even though above-mentioned countermeasure is done.
[Warning] Use in residential areas may cause interference.

■ Maintenance, inspection and repairs



- (1) Follow this manual when carrying out maintenance or inspections related to this control unit.
- (2) This unit must be repaired, serviced and inspected only by a worker that has received special training.
- (3) Always turn the power OFF before replacing the needle or bobbin, etc., on the head.
- (4) Use genuine replacement parts for repairs and maintenance.

■ Other safety measures



- (1) Keep fingers away from all moving machine parts (especially around the sewing machine needle, etc.).
- (2) Never drop the control unit, or place objects in the clearances.
- (3) Do not operate the sewing machine without the protective parts such as the cover, or protection devices such as the safety breaker.
- (4) If any damage is observed in the control unit, if the unit does not operate correctly, or if the operation is suspicious, always suspend operation. Only operate the machine after the supervisor has adjusted, repaired or inspected the machine.
- (5) The user must not make improvements or changes without instruction from Mitsubishi.



■ Caution displays and danger displays

- (1) In this manual, the dangers and danger levels that arise with incorrect handling are classified using the following displays.

| | |
|--|---|
|  Warning | The warning display shows that incorrect handling can lead to death or serious injuries. |
|  Caution | The caution display shows that incorrect handling can lead to injuries or damages to your house, household goods, and others. |

- (2) The meanings of these symbols are as follows.

| | |
|---|---|
|  | This symbol indicates that the instructions must be followed. |
|  | This symbol indicates hot temperature requiring caution. |
|  | This symbol indicates a prohibited action. |

| | |
|---|---|
|  | This symbol indicates an electrical hazard or caution (electric shock caution). |
|  | This symbol indicates that ground wire connection is required. |

- * Always deliver this manual to the end user.
- * Store this manual nearby where it can be referred to when necessary.

[2] Precautions for use

Warning

1. Do not place foot on the foot switch when turning the power ON.

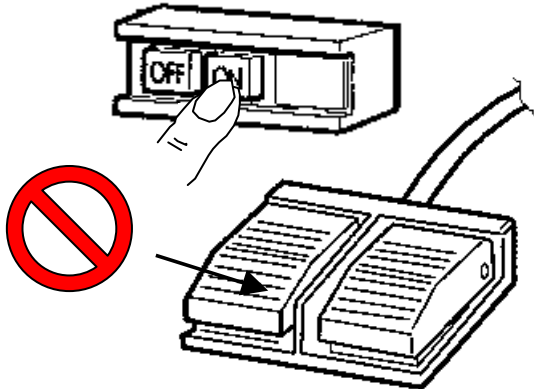

2. Always turn the power OFF when leaving the sewing machine.

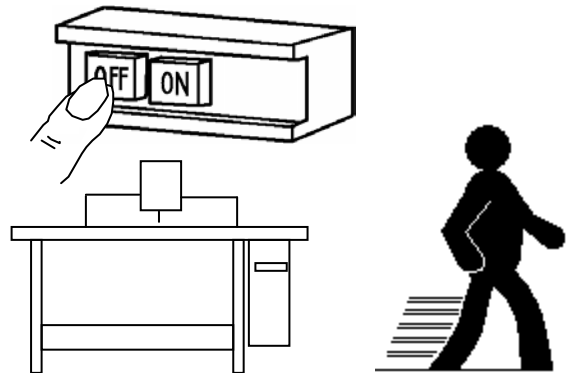

3. Do not inspect the control circuit with a tester.

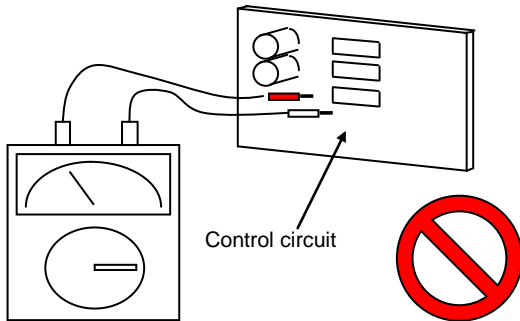

The tester voltage could be applied on the semiconductor parts, and cause damage.

4. Always turn the power switch OFF before tilting the sewing machine head, replacing the needle, or passing thread through the needle.

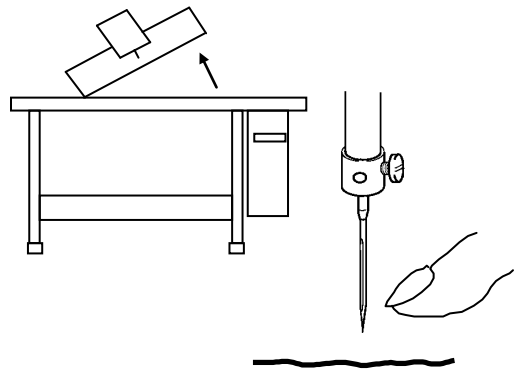

5. Always ground the grounding wire.

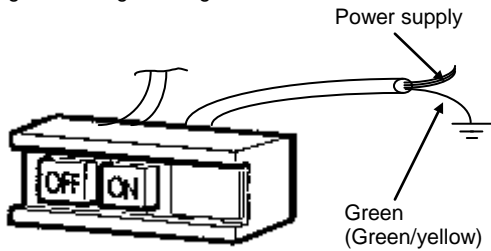

Always ground the provided grounding wire (green(green/yellow)).

6. Do not use excessive wiring.

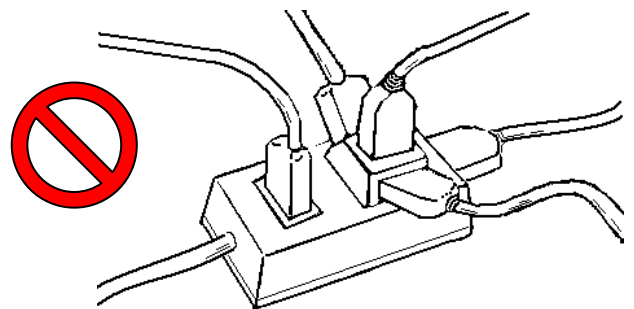

7. A high voltage is applied inside creating a hazardous state, so always turn the power OFF and wait ten minutes before opening the cover.

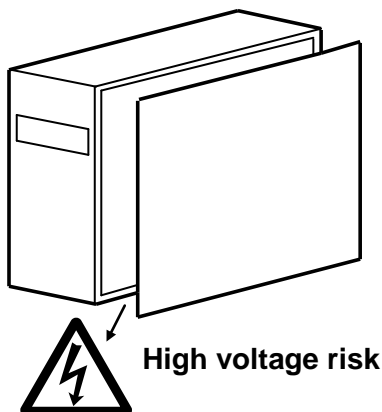

8. Radiation fins and other parts may be hot. Do not touch the parts.

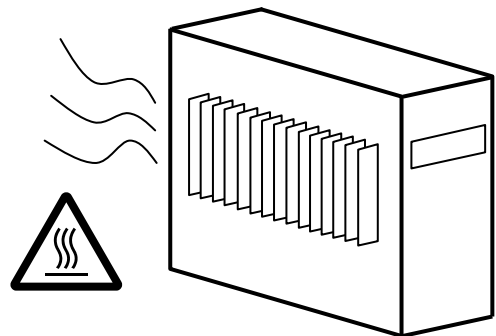

9. The sewing machine will coast to a stop when the power is turned OFF or a power failure occurs during sewing machine operation.
10. Always align the connector shape and direction, and securely insert the connector.
11. If the position detector's connector dislocates, or the sewing machine is completely locked, the motor will be turned OFF automatically for a set time to prevent burning. (Note that the motor may not turn OFF if there is incomplete locking or an overload.) When the fault has been recovered, turn the power OFF and ON once to resume normal operation. The same type of operation will take place if a detector fault or disconnection occurs.

12. Use the machine away from strong noise sources such as high frequency welders.

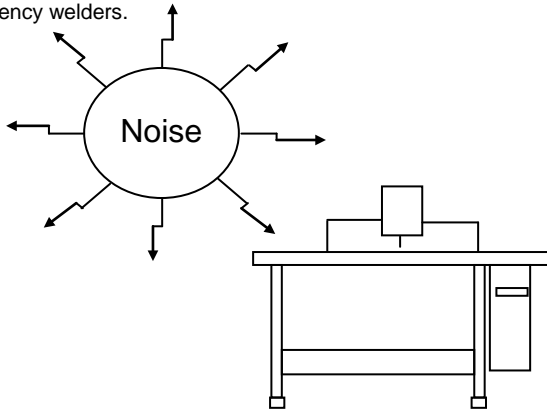

13. When connecting the external switch to an optional connector, etc., keep the signal wire as short as possible. A long wire could cause malfunctions.

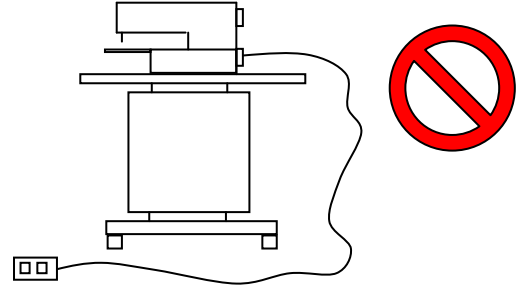

Use a shielded wire for the signal wire when possible.

14. If the fuse blows, remove the cause, and replace the blown fuse with one having the same capacity.

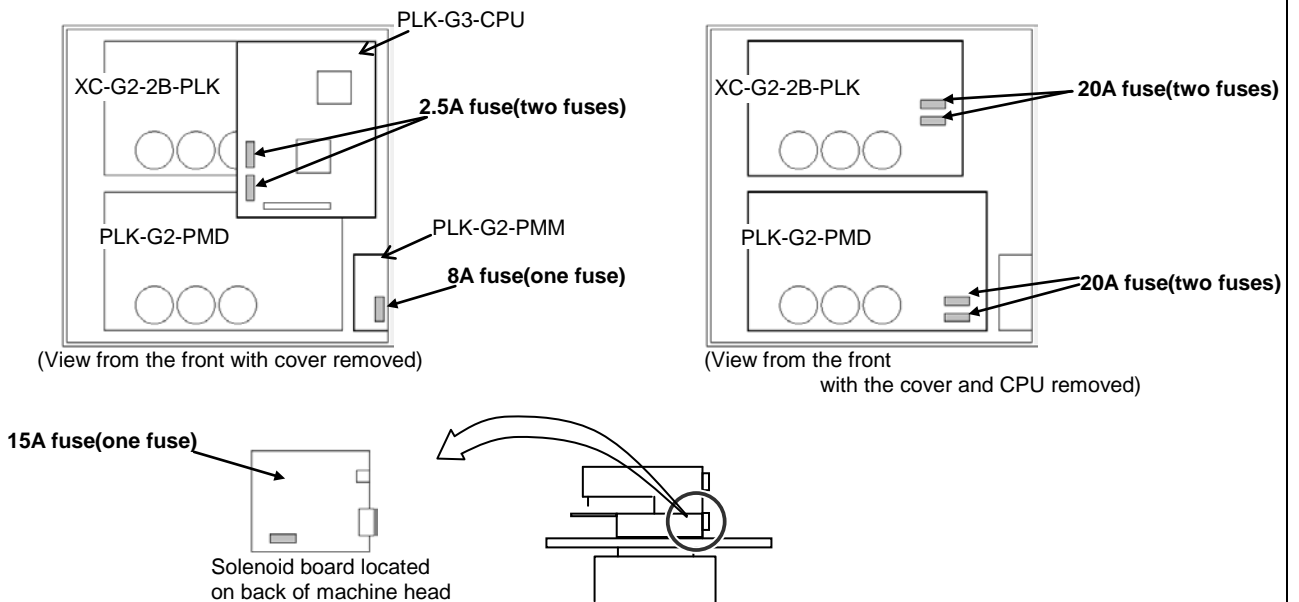

15. Attention when power supply is turned on again

Please make sure not to turn on the power supply switch until after the LED on the front panel of the control box has completely turned off.

(Please do not turn on the power supply again while displaying the screen of the operation panel.)

* Please note that if power supply is turned on again while LED still turns on, clamp outputs (O4, O5 port) may go down.

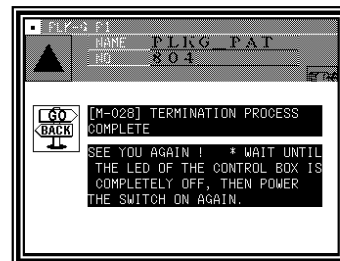

16. When the value of the sewing area limit is changed or the limit setting is deactivated, note the collision and take care safely. Also when using it outside the range where the mechanism can be operated, it can not assume the responsibility for all problems caused by it.

[3] Explanations of basic screen, icons and operation

Note When power supply is turned on, if there is not sewing pattern data in the internal memory, the message of [PATTERN DATA DOES NOT EXIST] is displayed. Press , then the standard screen is displayed.

Note When you adjust the contrast to make the operation panel screen easier to view, refer to Chapter 8, "Adjusting the Liquid Crystal Contrast."(Page[3]-6)

1. Screen configuration

(1)Sample screen 1 (Standard screen 1)

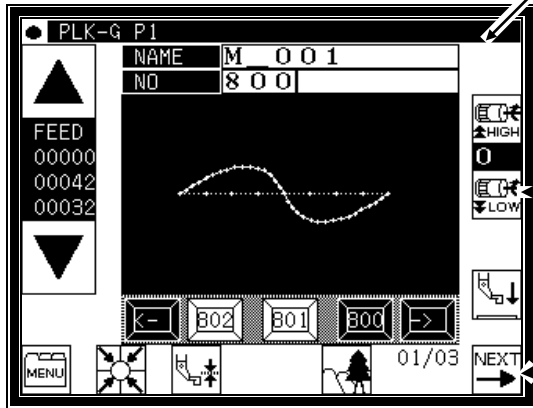

[Line at top of screen]
Normal: Index
(simple explanation of screen)
When any icon is pressed:
The explanation for that icon will appear. (Refer to sample screen 2.)

Some icons will continue execution while the icon is held down.

Most icons will execute the operation when the finger is released.

(2)Sample screen 2 (While menu icon on Standard screen 1 is held down)

An explanation of the icon and the screen will appear.

This icon (menu icon) is pressed, so the icon will be highlighted.

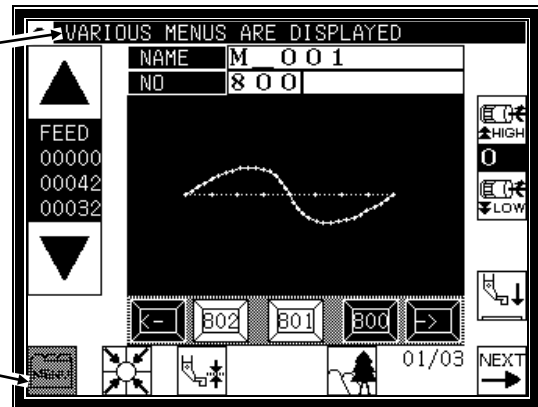

(3)Sample screen 3 (When menu is opened on Standard screen 1)

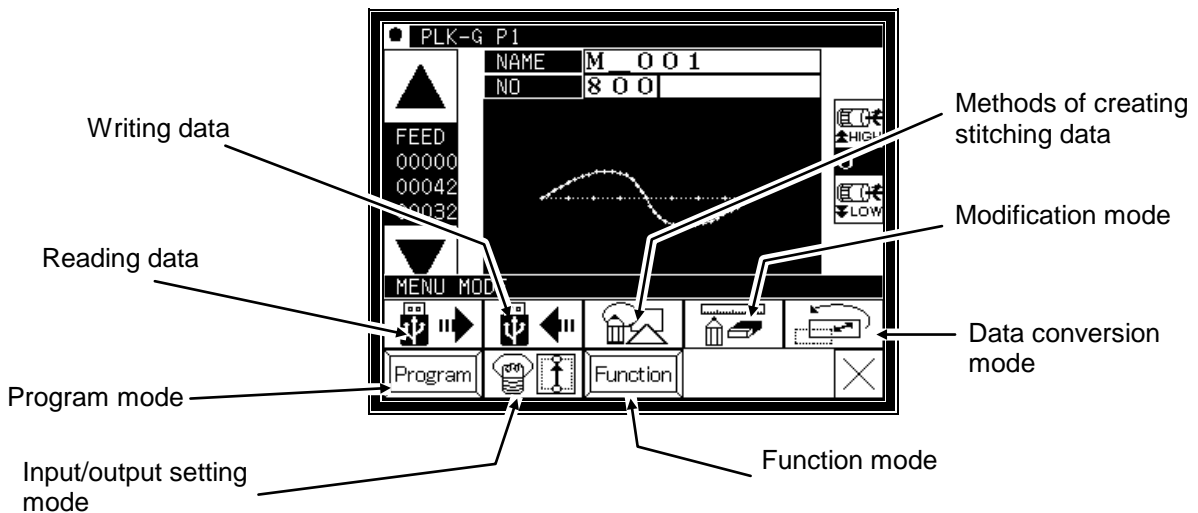

2. Explanations of Standard screen 1

The Standard screen 1 is explained in detail below.

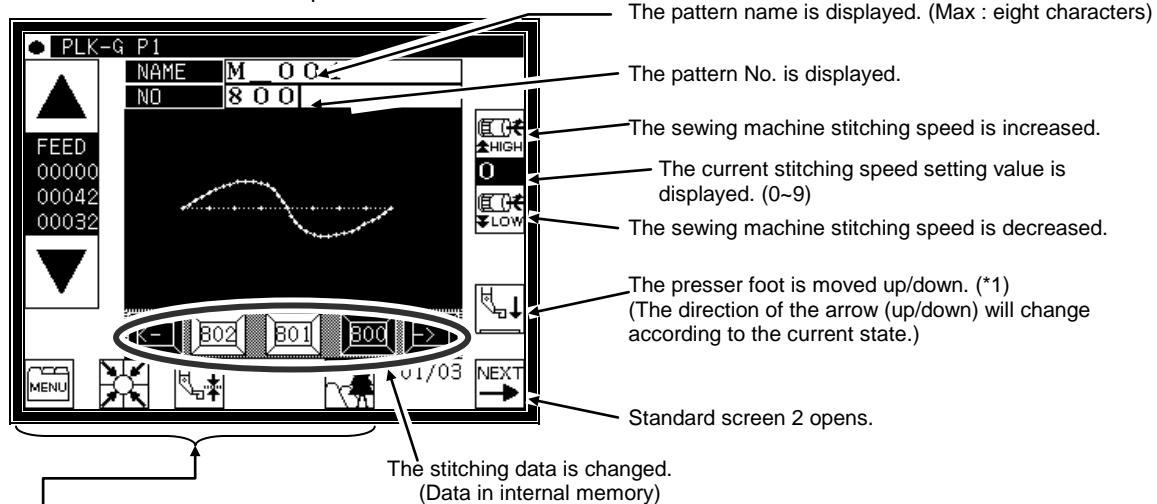

... Home position return will be executed.



... The menu window will open



... The Image screen will open.



... The screen of setting for material thickness will open.

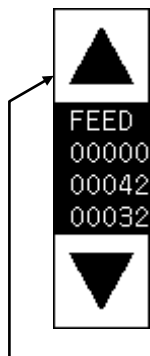

The stitching data type for the current work holder position is displayed.
(FEED, SEW, TRIM, etc.)

The current number of stitches is displayed.

The total number of stitches (including the feed data, thread cutting code, end code, and code data) will be displayed.

The total number of actual stitches (excluding the feed data, thread cutting code, end code, and code data) will be displayed.

The operation is confirmed (Jogging in forward/reverse direction)

(1) If the work holder is lowered after home position return and the forward jogging direction (upward arrow) is pressed, the XY table (work holder) will move according to the stitching data. When the icon is released, the operation will stop at that position. When the jog minus direction (downward arrow) is pressed, the XY table (work holder) will move in the direction that the stitching data returns. When the icon is released, the operation will stop at that position.

(2) Check pattern data is correct by jogging buttons, before press start pedal.

(3) During operation, the presser bar lifting will lower at stitching sections in the stitching data, and will rise at the feed data sections.

(*1) Presser bar lifting : Lowering the presser bar lifting when threading the needle is handy.



Caution

Turn the power OFF before threading the needle.

3. Explanations of Standard screen 2

Displays the Standard screen 2 from the Standard screen 1, by pressing .

The Standard screen 2 is explained in detail below.

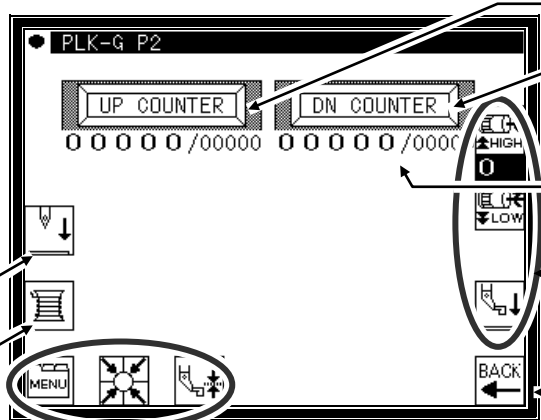

- The Up Counter screen is displayed.
- The Down Counter screen is displayed.
- The counter value is displayed. (Current value/setting value)
- Same as Standard screen 1.
- Returns to Standard screen 1.

 ... Bobbin winding mode (The presser bar lifting will lower, and the Bobbin Winding Setting screen will open.) (The details are explained on the next page.)

 ... Moves the needle up/down.

4. The Up Counter screen is explained below

(The Down Counter screen is the same, except for the valid/invalid icon design.)

* The methods of counting with the up counter (down counter) and clearing the counter are determined by the program mode setting. (Page[16]-7)

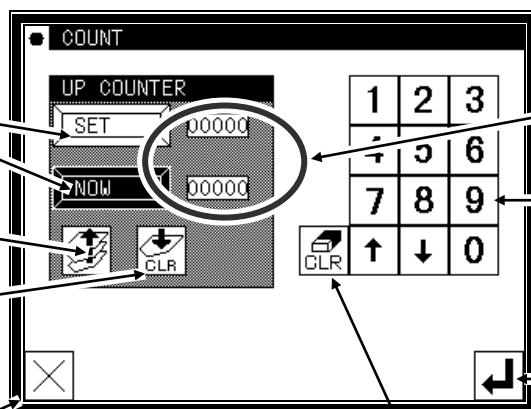

- Changes the setting value or current value.
- Changes the validity of the up counter.
- Clears the current value. (Press  to clear the setting value.)
- Returns to the previous screen.
- Displays the setting value and current value.
- Use to change the setting value and current value.
- Determines the settings.(Returns to Standard screen 2.)
- A set value or the selected value is cleared.

●When this screen is displayed, sewing cannot be performed.

5. The Bobbin Winding screen is explained below

This screen is used to wind thread on the bobbin. (The presser bar lifting will lower when the bobbin winding icon is pressed on the Standard screen 2.)

When the work holder switch is turned ON and the start switch is turned ON, the sewing machine will start rotating at the set speed. The XY table will not move at this time. The sewing machine will stop at the needle UP position when the start switch is turned OFF.

* The bobbin winding operation is determined by the program mode setting. (Page[16]-10)

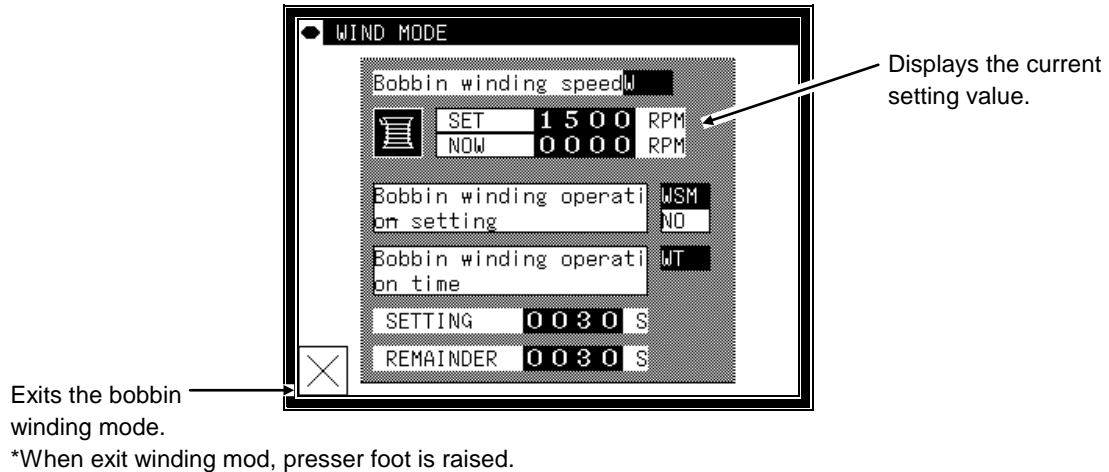

6. Explanations of basic icons

The basic icons used commonly on several screens are explained in this section.



... Executes home position return.



... Enter : determines the settings, etc.



... Returns to the previous screen.



... Exits the current mode.



... Cancel : undo the previous operation.



... Opens the menu window.



... Displays the previous/next list when lists are displayed (pattern data list, mode list, etc.)



... Turns skip jogging ON/OFF, and opens the operation setting screens.

7. Explanation of operations

(1)Stitching operations

[1] Reconfirm the stitching data before starting. Take special care to the set stitching speed.

[2] The stitching speed is determined according to the set speed and stitch length. The maximum stitching speed is determined by the speed setting, and the stitch length limits the stitching speed.

[Caution] Do not change the sewing machine stitching speed during operation except in emergencies.
(Changing the speed can cause fault such as thread catching faults.)

[3] Set the material to be stitched, and turn the work holder switch ON. Next, when the start switch is turned ON, the sewing machine will start rotating and stitching. Once started, stitching will continue even the operator's foot is released from the start switch. When the stitching is completed, and the work holder returns to the home position, the sewing machine will stop and the work holder will automatically rise.

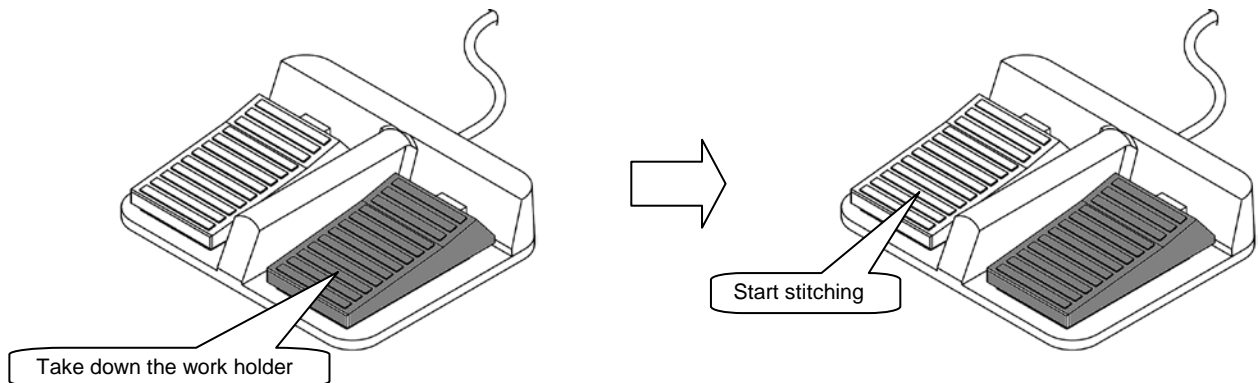

(2)Halting

To stop during the stitching, press the HALT switch (installed on sewing machine head; refer to following drawing). The sewing machine will stop at the needle UP position. (Standard default setting.)

To cancel the halted state, press the HALT switch again. The following operations will be possible when the halted state is canceled.

[1] Restart of stitching by pressing start switch. (gray pedal)

[2] Movement to stitching start position with forward jog/reverse jog icons.

[3] Lifting of work holder by pressing work holder switch. (black pedal)

[4] Change of stitching speed by setting stitching speed.

[5] Lifting/lowering of presser bar lifting.

[Note] The needle position during the halted state can be set with the program mode .

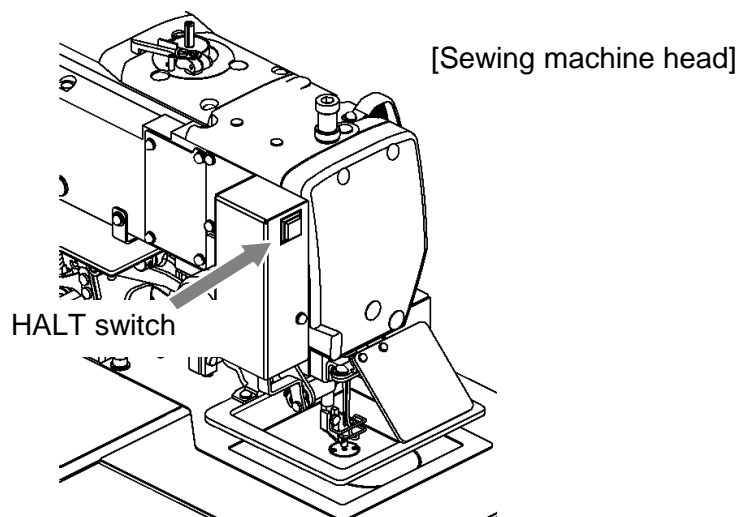

(3) Restitching methods

Restitching can be carried out using the previously explained halt function.

If the operation is halted due to needle thread breakage, etc., set the needle at the UP position, and then using the forward jog/reverse jog icons, move to the position where the thread broke. Tie the needle thread, etc., and restart stitching by pressing the start switch.

! Caution

If the needle must be thread while the power is ON, do not turn on the start switch while threading. Doing so initiates machine rotation, resulting in an extremely dangerous situation. To ensure that the start switch is not turned on during threading, take measures such as moving the start switch away from your feet.

8. Adjusting the Liquid Crystal Contrast

(1) Entering the function mode

▶ Press  on the standard screen, and open the menu mode.

▶ Press 

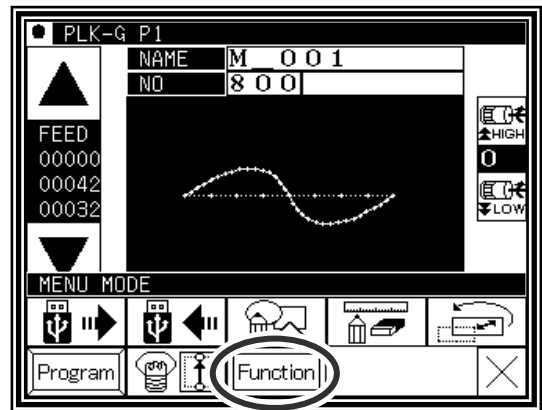

(2) Entering the screen mode

▶ Press  on the function mode menu, and open the screen mode.

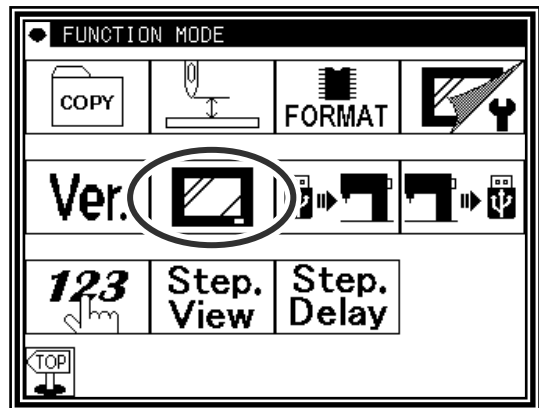

(3) Adjustment of LCD contrast

▶ Set the liquid crystal contrast value using the up and down arrow icons.

▶ After setting the value, press the  [Enter] icon to apply the value.

▶ Back to Standard screen, then contrast setting is completed.

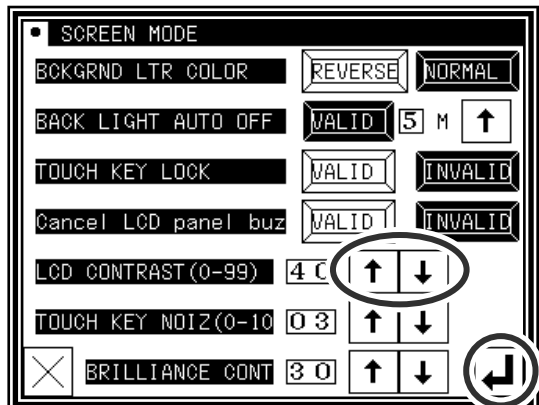

[4] Sewing Data Compatibility

1. Number and type of Sewing Data

| Number | Type | Explanation |
|-------------------|---------|--|
| 100 ~ 999 (*1) | G data | This is data created with the PLK-G series. (The maximum number of stitches is 20,000 stitches.) |
| 100 ~ 399 | A data | This is data created with the PLK-A series (old model). |
| 400 ~ 499 | BA data | This is data created with the PLK-B series and E series (old model). (For embroidery data) |
| 600 ~ 799 | B data | This is data created with the PLK-B series and E series (old model). |

(*1) : Pattern data which made in G series can be registered up to 900 (No.100-999) but number of the pattern is changed by a size of each pattern.

2. Sewing Data Compatibility

The following table shows the handling capabilities of the sewing machine (PLK-G series) with respect to four types of sewing data.

| Type | Reading | Stitching | Continuous input, Modification and Conversion | Writing |
|---------------|-----------------------|------------------|---|-------------------|
| A data | Available (*1)(*3) | Available | Available | Available (*2) |
| BA data | Available (*1) | Available | Available | Available (*2) |
| B data | Available (*1)(*4) | Available | Available | Available (*2) |
| G data | Available | Available | Available | Available |

(*1) : The sewing data can be read after converting to G data.

(*2) : It is written as G data.

(*3) : A-data registered patterns (No.300~339) and
A-data compounded patterns (No.500~549) can not be read.

(*4) : B-data registered patterns (No.800~839) and
B-data compounded patterns (No.900~949) can not be read.

[5] Reading, writing and erasing data

1. USB

To perform actions such as storing (reading/writing) sewing data on a device other than the internal memory or reinstalling the system, a USB device is used. The device is connected to the USB connector on the front side of the control box.

When using a USB device, be sure to fully insert the device into the USB connector. (Refer to the figure below.)

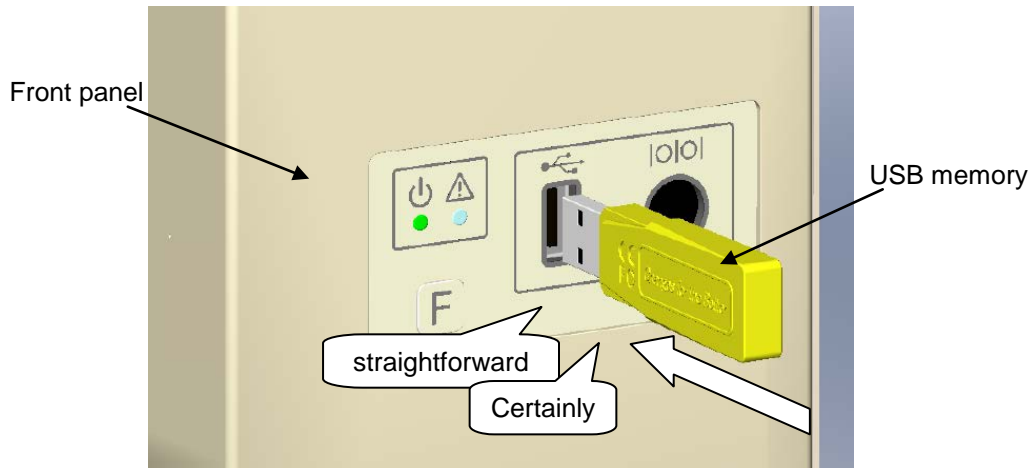

[Caution]

- Connect the USB device during use only. After use, remove and store the device in an appropriate location. When USB device is not connected, insert protection cap to the USB connector. (Protection cap must be inserted correctly according to the shape of the USB connector)
- Sewing cannot be performed with the USB device inserted.
- Do not insert the USB device during sewing.
- Be careful that nothing bumps into the inserted USB device.

Conditions of Application

- USB1.1 or USB2.0 compatible USB memory and USB floppy disk drive (Note, however, formatting cannot be performed with a floppy disk drive connected to the machine.)
- Required power supply: USB compatible, 500mA or less

Note The write-protector might not be able to recognized according to the kind of USB device. Please make sure to release the write-protection before writing data to the USB memory.

Inapplicable Devices

■ **Never connect the following devices.**
(Doing so causes malfunctions.)

- USB device requiring an external power supply (including Computer devices)
- USB hard disk drive, keyboard, mouse
- USB memory with fingerprint authentication function or with security function
- USB memory with hub function
- Media reader
- USB device without data storage function

2. Reading

Operation points

- Select "Read mode" from the menu.
- Select the target (internal memory/USB memory).
- Select the data, and execute reading.

Operation details

(1) Selecting data read

Note Data reading excluding the start position cannot be executed. Read pattern data after home returning.

▶ Press  on the standard screen, and open the menu mode.

▶ Press  .

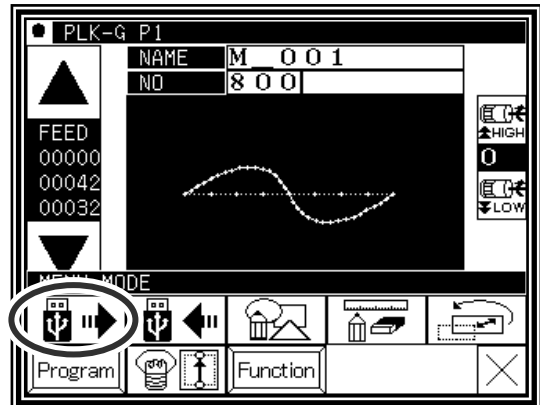

(2) Select the target (internal memory/USB memory).

▶ When the screen first opens, the mode to read from the internal memory is selected.

(The mode display at the upper left of the screen is )

▶ Press  to change to reading from the USB memory.

(The mode can also be changed by pressing )

Note If the USB memory is not inserted into the USB connector, USB memory icon can not be selected.

▶ If there is a large amount of data, press  to change the screen.

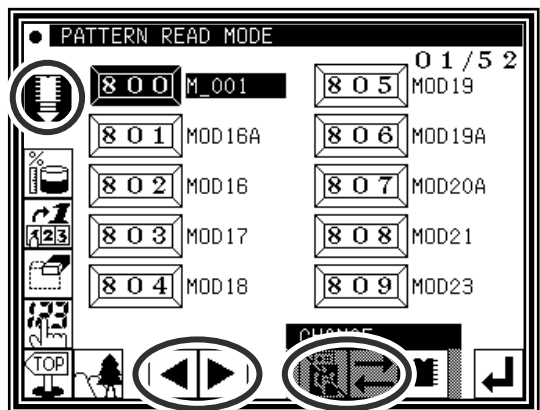

(3) Selecting and setting the data

▶ Press the number of the data to be read, and then press



Note When you read data from the USB memory and select a data number that already exists in the internal memory, a message confirming that you overwrite the data appears. If you do not overwrite the data, press the  icon. If you overwrite the

data, press the  icon.

▶ The read data will be displayed.

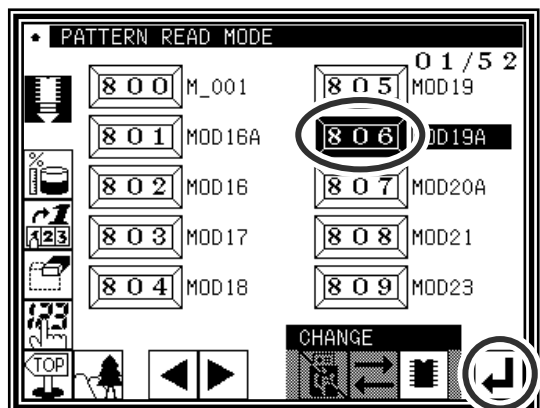

[Caution] When the target is the USB memory, do not remove the USB memory during reading.
(Doing so may result in data damage.)

Note

When the pattern data number is already known, it is possible to read by specifying the number directly by the following operations.
(Following operation is limited to reading from an internal memory.)

Reading [Direct reading mode]

Operation details

(1) Selects pattern data read button

Note Data reading excluding the start position cannot be executed. Read pattern data after home returning.

▶ Press , then menu screen is displayed.

▶ Press .

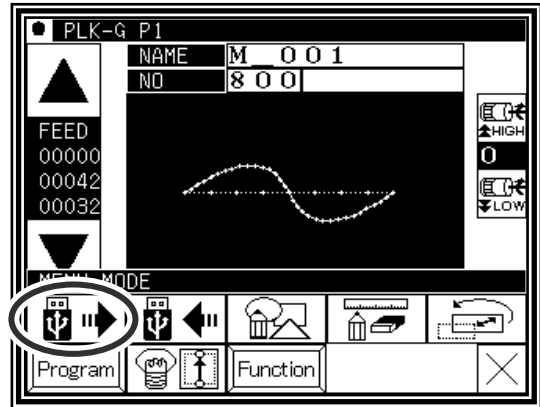

(2) Selects direct pattern number selection

Note Direct pattern number selection is possible only to the data stored into the internal memory.

▶ Press direct pattern number button .

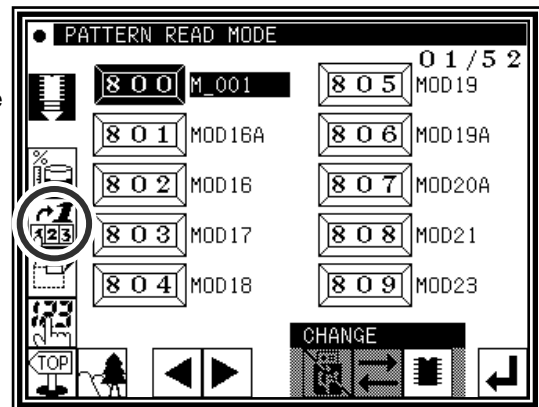

(3) Specifies pattern data number 1

(example. Case of reading number [861].)

▶ Press number button [8].

▶ Then 10 of pattern datas which number start from 8 are displayed.

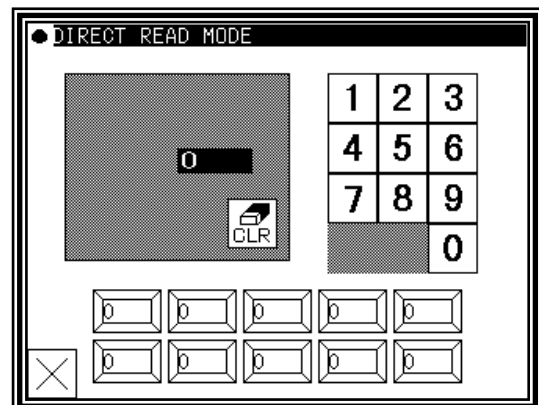

(4) Specifies pattern data number 2

- ▶ Next press number button [6].
- ▶ Then all pattern data which number starts from 86 is displayed.
- ▶ At this time, desired pattern number [861] is displayed, then press .

Note It is also available, if inputs 3 digits in the column as [861] and push  button.

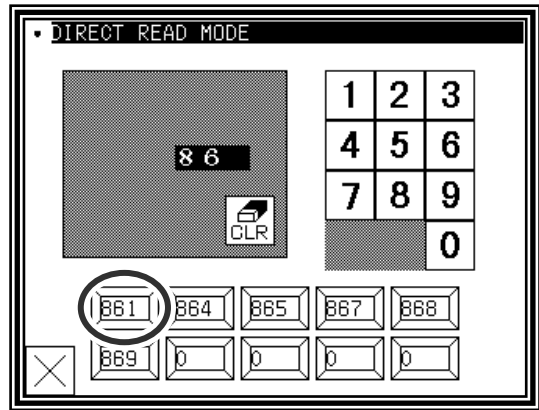

(5) Data read complete

- ▶ Standard screen with the figure of pattern number [861] is displayed.

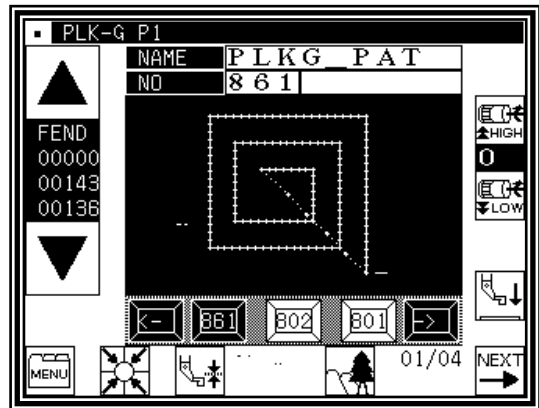



3. Writing

Operation points

- Select “Write mode” from the menu.
- Select the target (internal memory/USB memory).
- Set the pattern name and number, and execute writing.

Operation details



(1) Selecting data write

- ▶ Press  on the standard screen, and open the menu mode.
- ▶ Press .

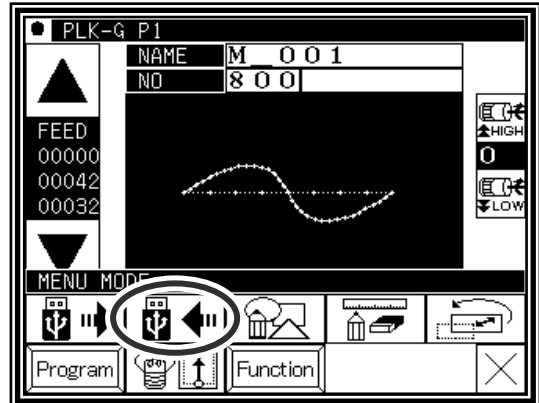
Note Data writing excluding the start position cannot be executed. Write pattern data after home returning.



(2) Setting the pattern number and name



- ▶ When the screen first opens, the mode to write to the internal memory is selected.
(The mode display at the upper left of the screen is )
- ▶ Press  to change to writing to the USB memory. (The mode can also be changed by pressing )

Note If the USB memory is not inserted into the USB connector, USB memory icon can not be selected.

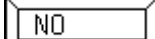
- ▶ Set the pattern number and name.

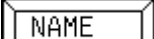
Press , and to change the name

press . Highlight the icon, and then change the setting.

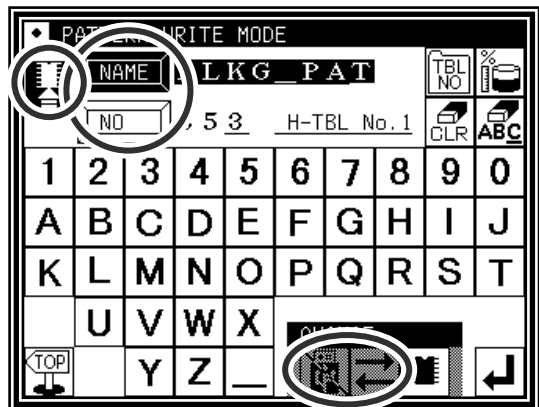

When the  icon is pressed, one of the alphanumeric characters from the right can be deleted from the pattern number or name. If press the  icon, all character is deleted.

(The pattern name can have up to eight characters.
Specify the pattern number within the range of “800” to “999”.)



(3) Starting writing

- ▶ Press .

Note If you try to write a data number that already exists for the write target, a message confirming that you overwrite the data appears. If you do not overwrite the data, press the  icon. If you overwrite the data, press the .

- ▶ The standard screen will reappears.

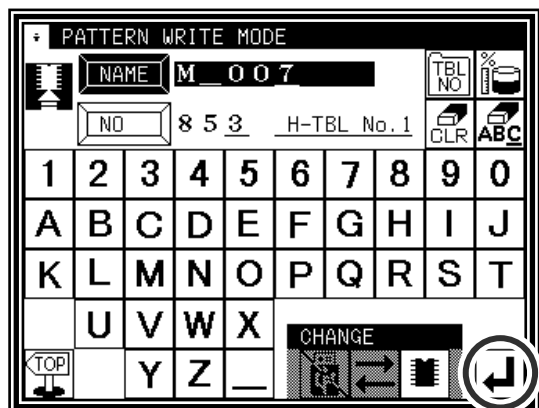

[Caution] When the target is the USB memory, do not remove the USB memory during writing.
(Doing so may result in data damage.)



4. Erasing

Operation points

- Select "Read mode" from the menu.
- Select the target (internal memory/USB memory).
- Select the data, and execute erasing.

Operation details



(1) Selecting data erase

- ▶ Press  on the standard screen, and open the menu mode.
- ▶ Press  .

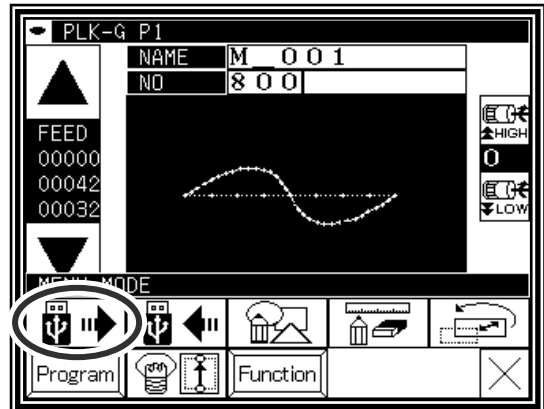
Note Data erasing excluding the start position cannot be executed. Erase pattern data after home returning.



(2) Select the target (internal memory/USB memory).

- ▶ When the screen first opens, the mode to erase from the internal memory is selected.
(The mode display at the upper left of the screen is )
- ▶ Press  to change to erasing from the USB memory.
(The mode can also be changed by pressing )

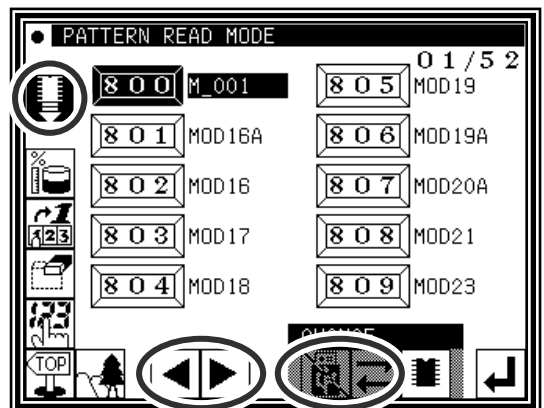

Note If the USB memory is not inserted into the USB connector, USB memory icon can not be selected.

- ▶ If there is a large amount of data, press  to change the screen.



(3) Selecting and erasing the data

- ▶ Press (Select) the number of the data to be erased, and press  .

Note A message confirming that you erase the data appears. If you cancel the erase operation, press the  icon. If you execute the erase operation, press the  icon. A message indicating that erasing is in progress appears, and then the Standard screen reappears.

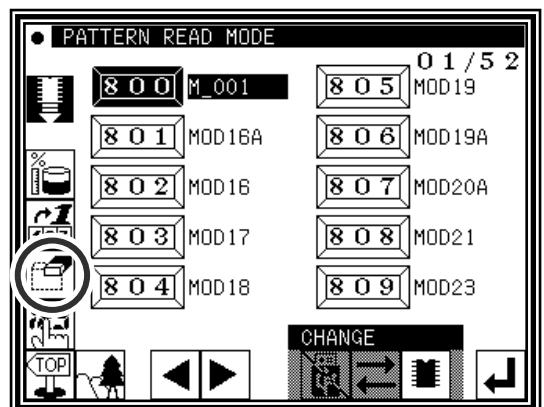

[Caution] When the target is the USB memory, do not remove the USB memory during erasing. (Doing so may result in data damage.)

5. Reading data with shortcut icons (Reading from internal memory)

Memo Data can be read out with easy operations.

Operation details

(1) Reading data

▶ Use the icon under the image area of the standard screen for call-up operation.
(No. 802 is used as an example here.)

▶ Press  to sequentially display the No. icon for the data written in the internal memory from left to right. (*1)

▶ Press  to sequentially display the No. icon for the data written in the internal memory from right to left. (*1)

▶ Press the  (No. icon). The data written in the internal memory will be called out. (The data having the number indicated on the icon will be called out.)

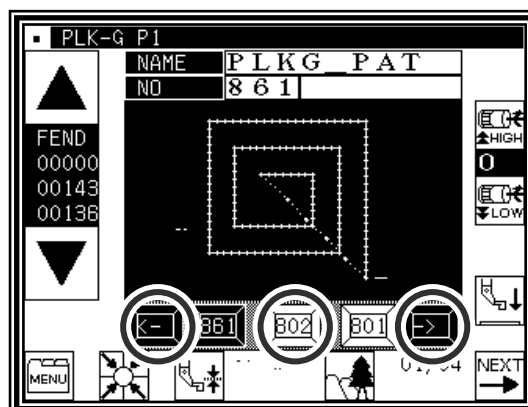



(*1) 20 data recently used are stored.

6. Rename the data number

Memo The number of the data that was saved in an internal memory can be changed.

Operation details

(1) Selecting data read

- ▶ Press  on the standard screen, and open the menu mode.
- ▶ Press .

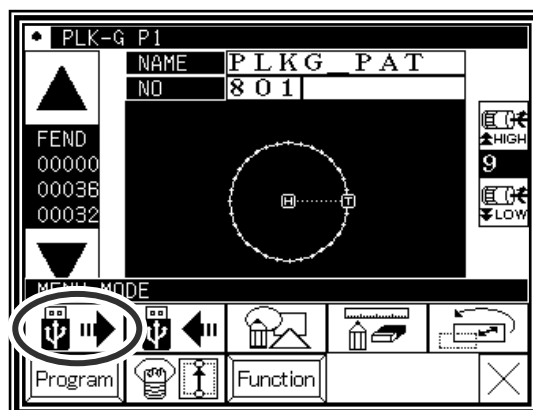

(2) Selecting the data

- ▶ Selecting the number of the data that wants to change and press .

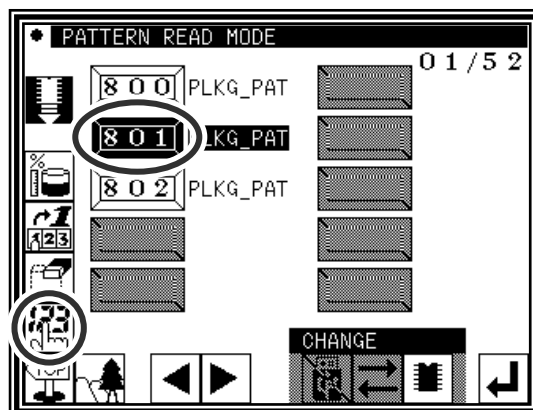

(3) Specifies number

- ▶ Specifies the number that wants to change using the numeric key.
- ▶ Press  after specifying.

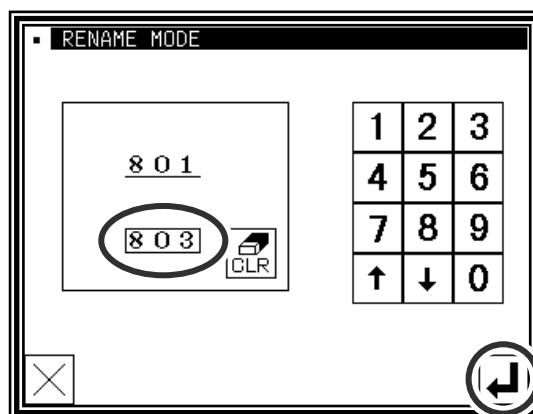

(4) Completing change

- ▶ The number of "801" was changed to "803" in this example.
- ▶ To return to the standard screen, press .

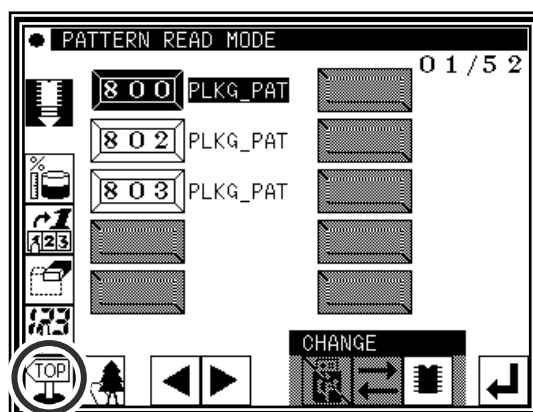

[6] Creating stitching data

1.Flow of data creation

The flow of creating simple stitching data, as shown below, is explained in this section.

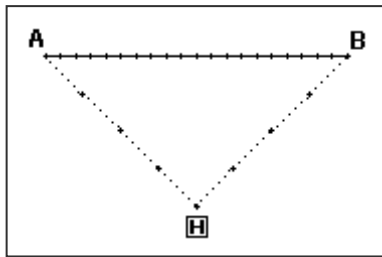

[Sample Fig.1]

The flow of operations for creating data and the transition of screen displays are explained here.

(1)Start from the standard screen

▶ Press  .

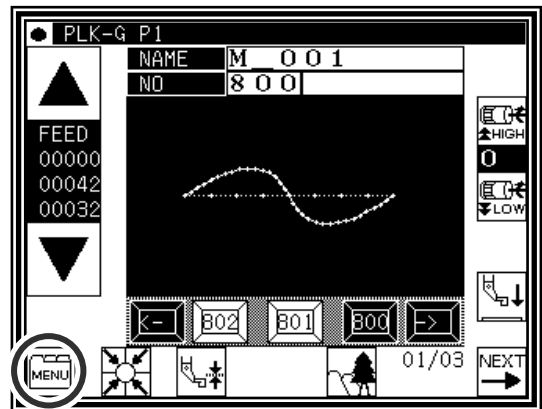

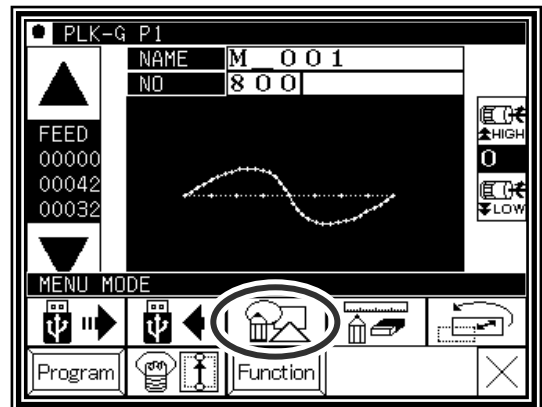

(2)The menu mode will open.

▶ Press  .



(3)The “INPUT MODE” screen will open.

- ▶ If the data has not been input on the standard screen, the  and  icons will not appear. To clear the input data and input new data, press .





To continuously input after the data already input, press

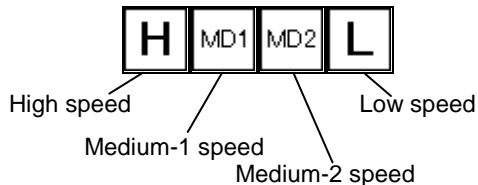

- ▶ Set the speed.



- ▶ Set the stitch length

Set in the range of 1 (0.1mm) to 200 (20.0mm) using the  to  and ,  icons.

- ▶ When completed setting the data, press .

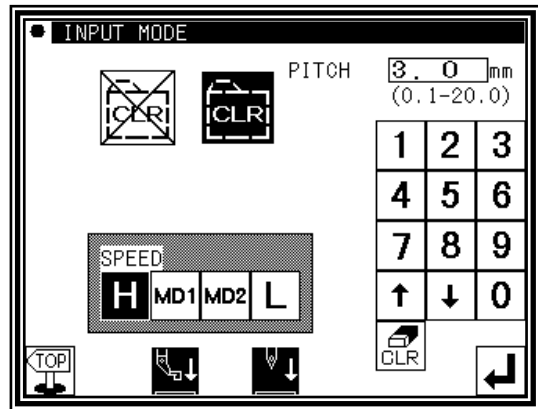



(4)The arrow input screen will open. (Input the sample Fig. 1 data.)

- ▶ When this screen is first opened, the code is set to FEED (feed data).

Press  and move to the position (A point) for starting stitching. (Movement using the arrow mark icons will change the X and Y position values displayed on the screen.)

After moving, press , and set the current position. (Data on feed data to point A will be created.)

- ▶ Next, the code is set to SEW (sewing), so press  and move to the position (B point) for ending stitching.

After moving, press , and set the current position. (Data on straight stitching to point B will be created.)

- ▶ Next, press .

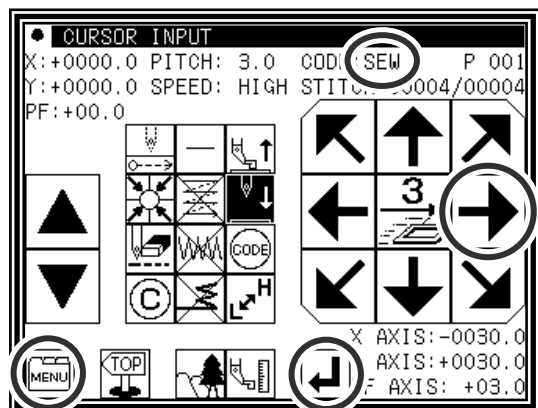
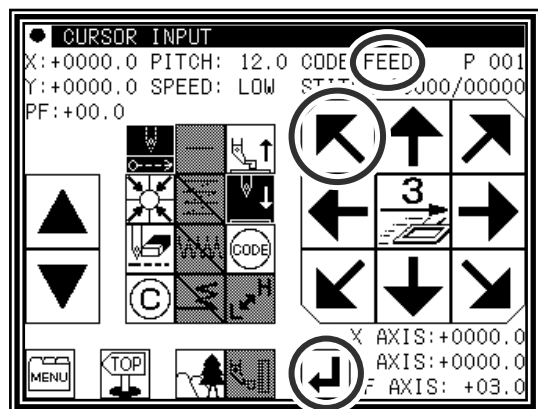

(5)The “INPUT MODE” menu will open.

- ▶ When  is pressed, the work holder will return to the home position, and inputting of data will be completed. (Data on feed data to the home position and the end code will be created.)

Caution The work holder will automatically return to the home position. Take care when the needle is lowered, etc.

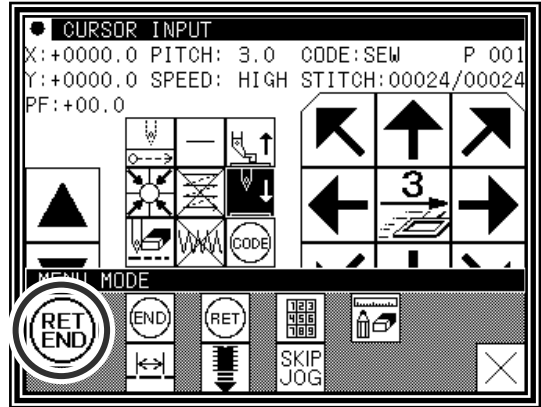

(6)A prompt for home position return will appear.

- ▶ Press 

Caution The needle will rise to the UP position. If the needle is not at the UP position, it may lower once and then return to the UP position.



(7)Select a saving method.

- ▶ After selecting the saving method, press  icon. (Refer to “[5] Reading, writing and erasing data”)

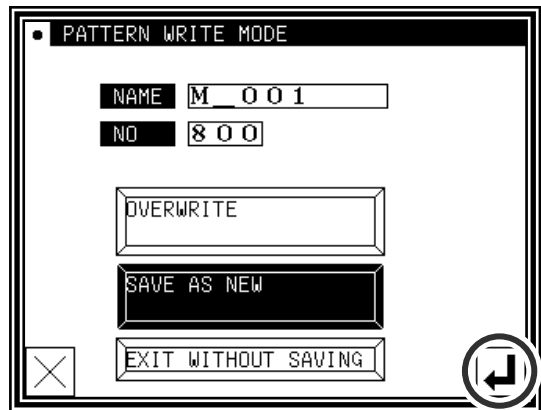

(8)The Standard screen will open.

- ▶ Return to the Standard screen and confirm the input data.
- ▶ This completes the input.

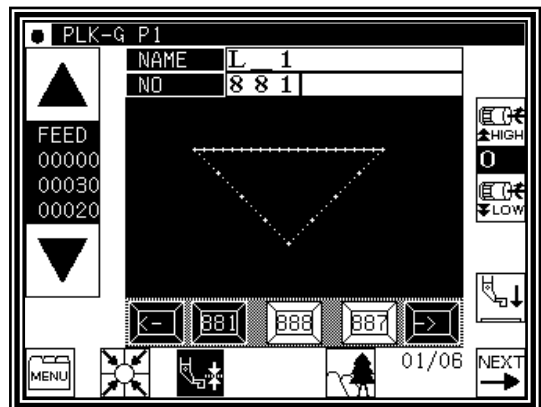

2. Description of arrow input screen

The arrow input screen is described below.

The screenshot shows the 'CURSOR INPUT' screen with the following data fields: X: +0000.0 PITCH: 12.0 CODE: FEED P 001, Y: +0000.0 SPEED: LOW STITCH: 00000/00000, PF: +00.0. At the bottom, it displays X AXIS: +0000.0, Y AXIS: +0000.0, and F AXIS: +03.0. A grid of arrow icons is visible, with a '3' in the center. Callouts [1] through [6] point to various icons and data fields.

The current status will be displayed.

"STITCH": Shows the "current needle position value/total number of stitches".

When the needle is at the final stitch (current needle position value = total number of stitches)

"X, Y": Shows the position values entered with the arrow mark icons.

"Stitch length", "speed", "code" : Shows the currently-set values.

"P": Shows the number of points entered for an arc, curve, etc.

During operation in the jog mode (current needle position < total number of stitches)

"X, Y", "Stitch length", "speed", "code" : Shows the needle data of the specified position.

Displays XY current stitch position as an absolute value based on the home position.

When the needle is at the final stitch (current needle position value = total number of stitches)
Arrow mark icons will appear and data entry will be possible. To enter the position value, move the work holder using the arrow mark icons.

During operation in the jog mode (current needle position < total number of stitches)
The image currently creating will be displayed.

[1]"Data entry method setting icon"

The basic data entry method currently set will appear. (Point, straight line, broken line, circle, arc, curve) Press this icon to display the data entry method setting screen.

[2]"Multi-stitching, reverse multi-stitching, offset data setting icon"

The multi-stitching, reverse multi-stitching, and offset data currently set will appear. (Not set, multi-stitching (feed data mode), reverse multi-stitching (feed data mode), multi-stitching (sewing mode), reverse multi-stitching (sewing mode), offset) Press this icon to display the multi-stitching, reverse multi-stitching, offset data setting screen. Using this screen, you can set detailed data.

[3]"Zigzag setting icon"

The zigzag currently set will be displayed (zigzag or non-zigzag). Press this icon to display the detailed zigzag data setting screen. Using this screen, you can set the detailed zigzag data.

[4]"Back tack setting icon"

The back tack currently set will appear. (No back tacking, start/end back tacking, overlap back tacking) Press this icon to display the detailed back tacking data setting screen. Using this screen, you can set detailed back tacking data.

[5]"Kind of code display"

FEED ----- Feed
 FEND ----- Feed end cord (Displayed while JOG is operating)
 SEW ----- Basic input (Straight line, Arc, Circle, Curve, Broken line, Point)
 P ----- Multiple sewing
 I ----- Reverse multiple sewing
 O ----- Offset sewing
 Z ----- Zigzag sewing
 B ----- Back tacking sewing
 (Others, the various code data is displayed while JOG is operating.)

[6] [Clamp speed switch icon]

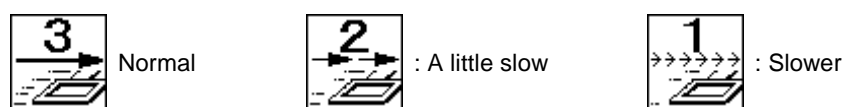

(Icon is changed whenever icon is pressed for a long period.)



“Cancel”: Cancels the last operation, and returns to the previous data entry point.



Caution The work holder will move. If the needle is lowered, be careful not to get injured.



“Delete last point”: Deletes the last determined point, and returns to the previous data entry point.



Caution The work holder will move. If the needle is lowered, be careful not to get injured.



“Change sewing speed”: Each time you press this icon, the set speed will be changed in the order of “HIGH → LOW → MD2 → MD1 → HIGH.”



The image display screen will be displayed.



The screen of setting material step will be displayed. (Refer to page [8]-2)

3.Description of menu

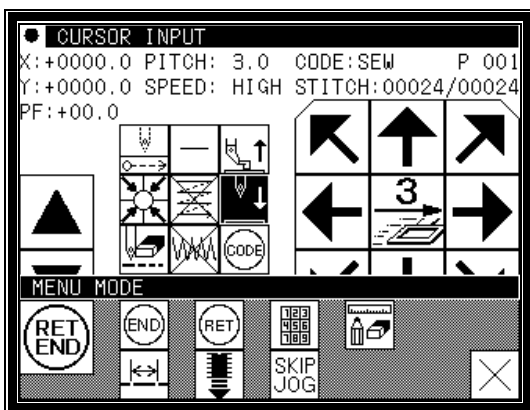

The data on feed data from the current position to the home position and the end code will be created, and the system will exit from the input mode.



The end code will be created, and the system will exit from the input mode.



The data on feed data from the current position to the home position will be created.



The screen is switched to the data creation screen that enables direct entry of numeric values.



The screen is switched to the input screen that enables data entry using the arrow mark icons (the arrow mark icons move the work holder).



You can enter the modification mode.



The stitch length change screen will appear.



When inputting data, the stitching data saved in the internal memory is added to the end of the data being input.



The skip jog setting screen will appear. (The details are explained on the next page.)

4. Skip jogging

Skip jogging allows movement to the target needle position at a faster speed than normal jogging. Skip jogging can be used in the input, modification and conversion modes.

(1) Turning skip jogging ON/OFF, and displaying the setting screen

- ▶ Press  found on the input screen menu, the modification mode and conversion mode.

(The explanations are made with the Modification Mode screen.)

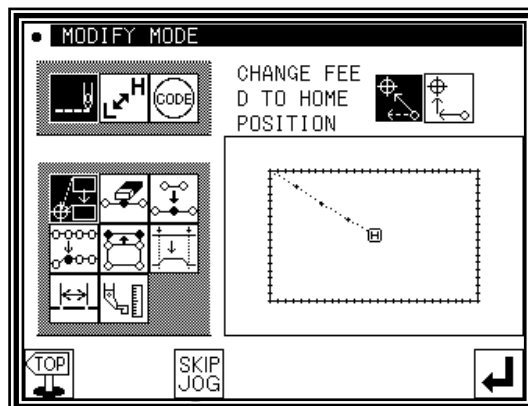

(2) Setting skip jogging

- ▶ Determine whether to use (ON) or not use (OFF) skip jogging.

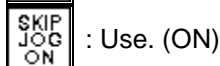
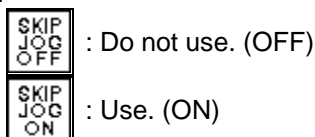

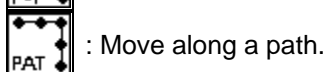
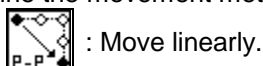

- ▶ Determine the movement method.



- ▶ Using the numeric keypad, set the number of movement stitches.

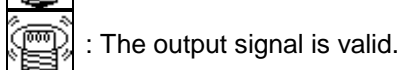
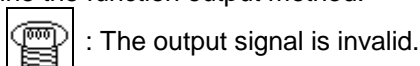



- ▶ Determine the function output method.

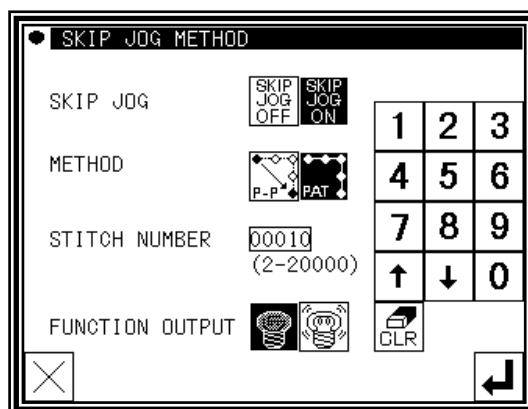

- ▶ After setting, press .



(3) Skip jog operations

- ▶ Skip jogging will start when  and  are pressed. ( and  are the normal jogging icons.)

Note Skip jogging will stop if one of     is pressed.

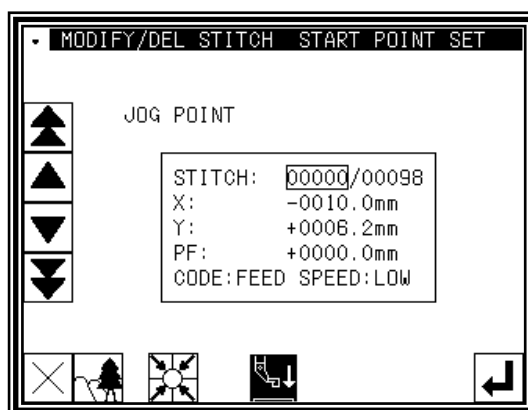

[7] Methods of creating sewing data



Caution Note that the needle will rise to the UP position when the "Home position Return" icon is pressed. (If the needle is not at the UP position, it may lower once and then return to the UP position.) By removing the presser bar lifting from sewing machine, data can be input safely and accurately.

Basic Inputs

| Function | icon | Explanation |
|-------------------------|------|---|
| Linear ([7]-1) | | 2-point input: A linear line is created between the current position (already input) and the newly input point. |
| Arc ([7]-4) | | 3-point input: An arc, passing through the current position (already input) and two newly input points, is created. |
| Circle ([7]-8) | | 3-point input: A circle, passing through the current position (already input) and two newly input points, is created. |
| Curve ([7]-11) | | A curve passing through the current position (already input) and the input point (up to 300 points possible) is created. |
| Broken line ([7]-15) | | A broken line connecting the current position (already input) and the input point (up to 300 points possible) is created. |
| Point ([7]-18) | | The point can be input one stitch at a time. * The distance between the points must be within 20mm. |
| Code ([7]-20) | | The code by which various controls are done can be input. |

1.Linear input

Operation points

- Designate linear input ()
- Input two points (A linear line is created between the current position (already input) and the newly input point.)

[Example] The following type of sewing data will be created.

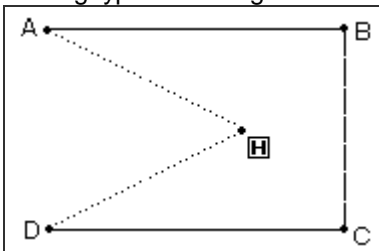

Operation details

(1) Inputting feed data to A point

- Press and on the Standard screen. After making the various settings on the Data Setting Input screen, the Arrow Input screen will open. (Refer to Page[6]-2)
- Check that the code is set to FEED. If different code is set, press and set the code to FEED.
- Press the arrow icons and move to the A point. (Feed data to A point.)

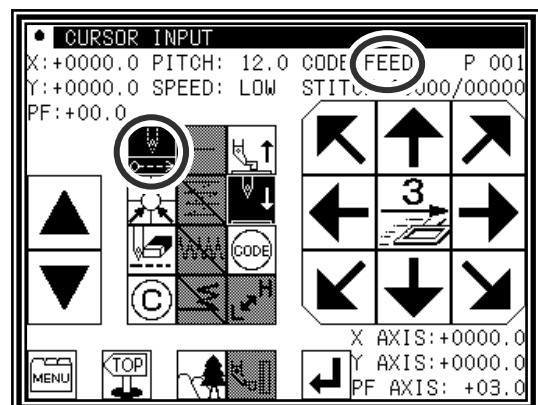

(2) Setting feed data to A point

- ▶ The movement amount can be confirmed.
[Example] X: -20.0, Y: +10.0
- ▶ Press  to set the data.
(Data on feed data to point A will be created.)
- ▶ The movement amount will be cleared.
X:+0.0, Y:+0.0
- ▶ The code will change to "SEW".

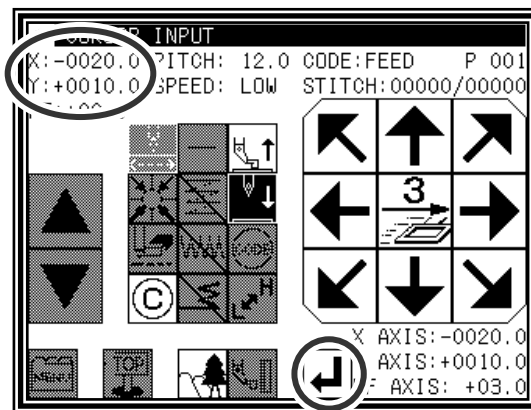

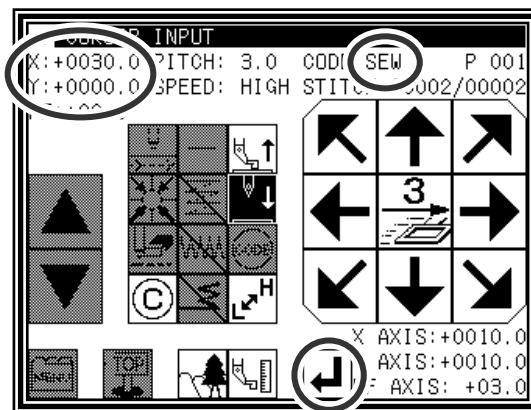

(3) Inputting stitching to B point

- ▶ Press the arrow icons and move to the B point.
- ▶ Press  to set the data.
(Data on straight stitching to point B will be created.)



(4) Inputting stitching from C point to D point

- ▶ Press the arrow icons and move to the C point.
- ▶ Press  to set the data.
(Data on straight stitching to point C will be created.)
- ▶ Press the arrow icons and move to the D point.
- ▶ Press  to set the data.
(Data on straight stitching to point D will be created.)

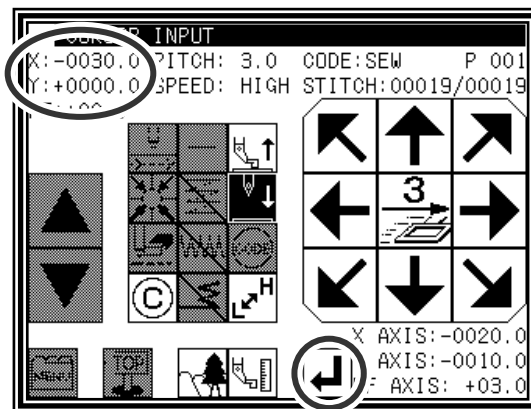

(5) Setting stitching to D point

- ▶ Press .

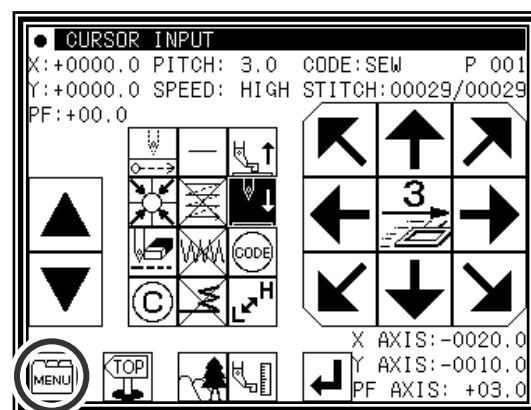

(6) Inputting the return/end code



(Data on feed data to the home position and the end code will be created.)

Caution The work holder will automatically return to the home position. Take care when the needle is lowered, etc.

▶ A prompt for home position return will appear.

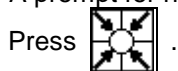

Caution The needle will rise to the UP position. If the needle is not at the UP position, it may lower once and then return to the UP position.

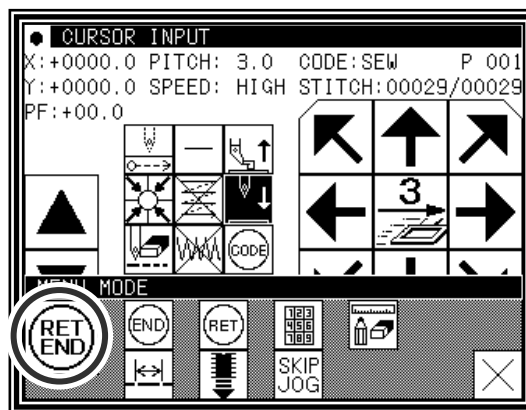

(7) Select a saving method.



▶ After selecting the saving method, press  icon.

(Refer to section [5] Reading, writing and erasing data.)

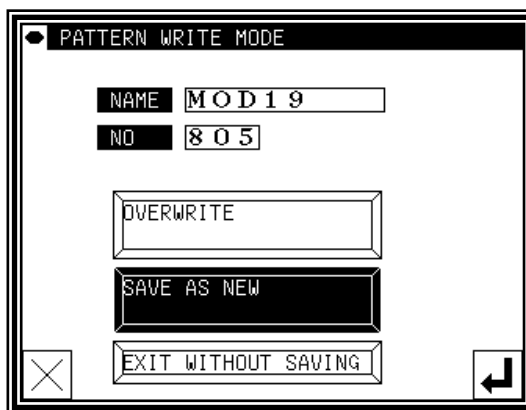
▶ Return to the standard screen.



(8) Confirming the data

▶ Confirm the data. Press the jog icons ( ) so the sewing machine movement can be confirmed. (Even if the data input has not been completed, if the data input last has been set, the movement can be confirmed in the same manner.)

▶ If the data must be modified, refer to section [11] Modification mode Modifying the stitching data.

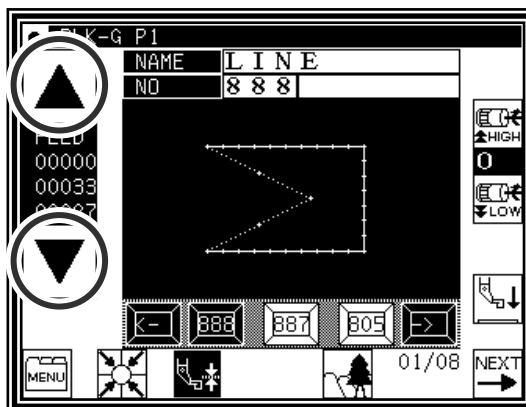

2.Arc input

Operation points

▪ Designate arc input ()

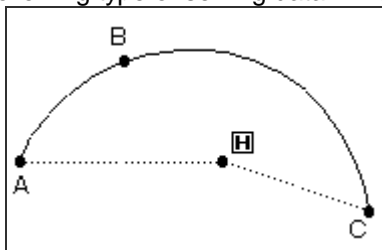

▪ Input three points (An arc, passing through the current position (already input) and two newly input points, is created.)

[Example] The following type of sewing data will be created.



Operation details

(1) Inputting feed data to A point

- ▶ Press  and  on the Standard screen. After making the various settings on the Data Setting Input screen, the Arrow Input screen will open. (Refer to Page[6]-2)
- ▶ Check that the code is set to FEED. If different code is set, press  and set the code to FEED.
- ▶ Press the arrow icons and move to the A point. (Feed data to A point.)

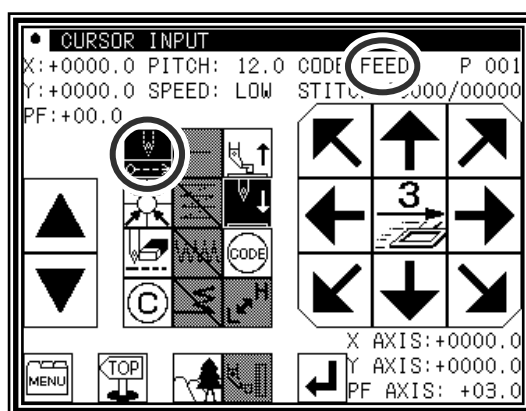

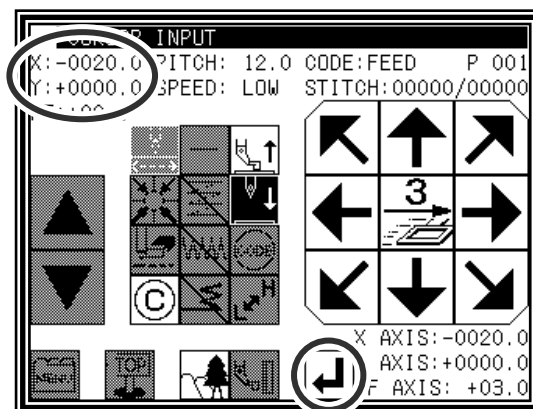

(2) Setting feed data to A point

- ▶ The movement amount can be confirmed.
- ▶ Press  to set the data. (Data on feed data to point A will be created.)



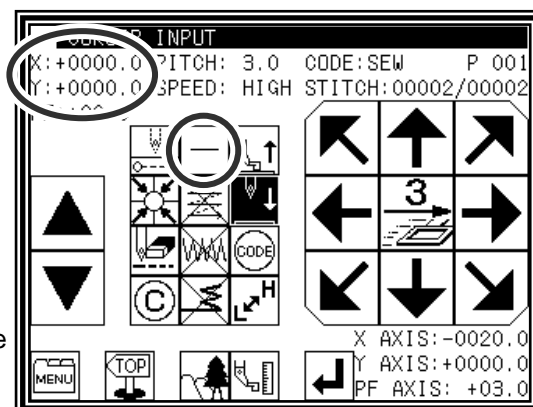

(3) Changing the input method

- ▶ The movement amount will be cleared.
- ▶ The code will change to "SEW".
- ▶ If the stitching type is not  "ARC INPUT", (if the type is  "LINEAR INPUT"), press  and change the type. (The currently set stitching type will be displayed on the icon.)



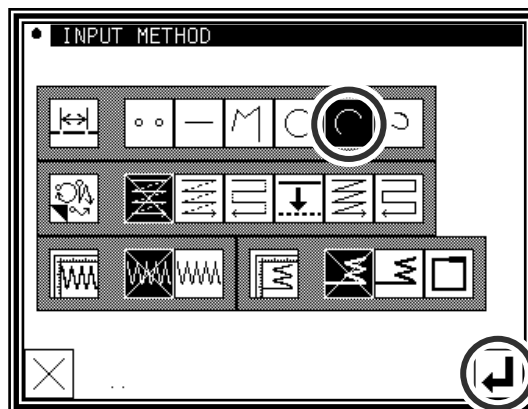

(4) Designating arc input

- ▶ Press  and then press .
- ▶ The system will return to the arrow input screen.



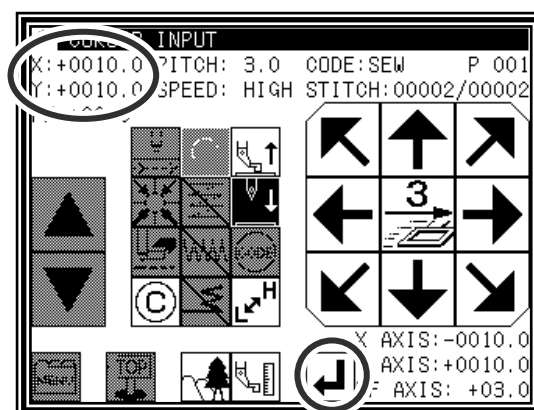

(5) Setting B point and C point

- ▶ Press the arrow mark icon to move to point B.
- ▶ The movement amount can be confirmed.
- ▶ Press  to determine point B.
- ▶ Press the arrow mark icon to move to point C.
- ▶ Press  and set the arc input.



(6) Creating the arc input data

- ▶ The confirmation message "Create arc" will appear.
- ▶ Press  to return to the point C data entry screen.
- ▶ Press  and start creation of the arc input data. (The arc will be created.)
- ▶ A message indicating that the data is being created will appear.

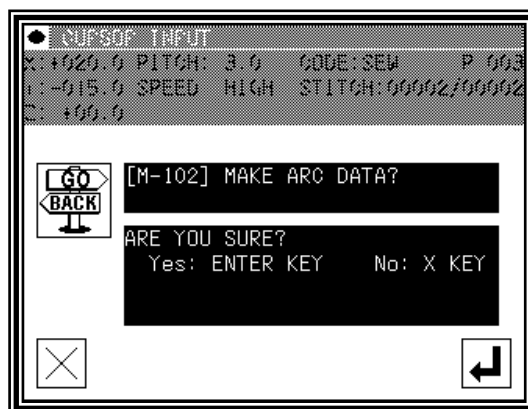

(7) Completing creation of the arc input data

- ▶ Press .

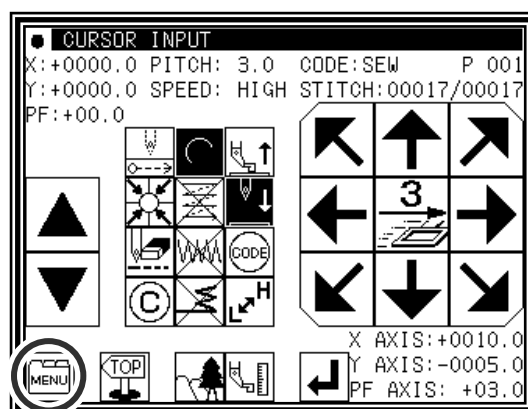

(8) Inputting the return/end code



(Data on feed data to the home position and the end code will be created.)

Caution The work holder will automatically return to the home position. Take care when the needle is lowered, etc.

▶ A prompt for home position return will appear.

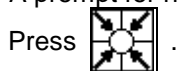

Caution The needle will rise to the UP position. If the needle is not at the UP position, it may lower once and then return to the UP position.

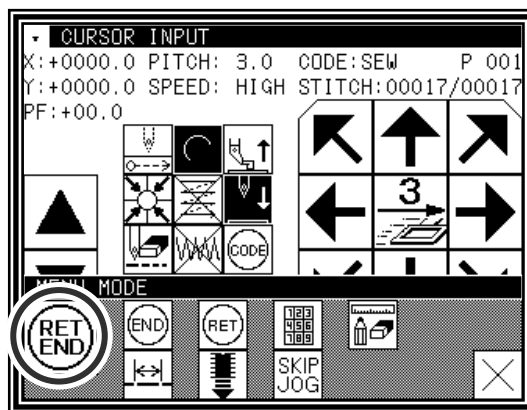

(9) Select a saving method.



▶ After selecting the saving method, press  icon.

(Refer to section [5] Reading, writing and erasing data.)

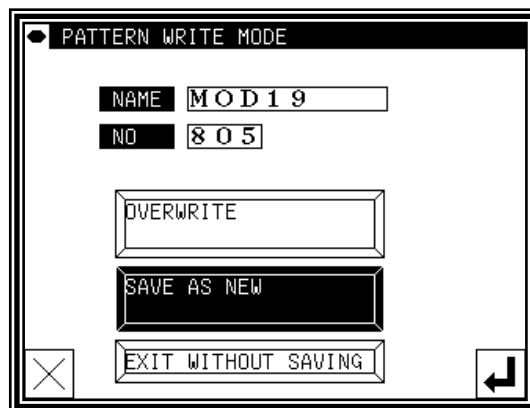
▶ Return to the standard screen.





(10) Confirming the data

▶ Confirm the data. Press the jog icons ( )

so the sewing machine movement can be confirmed. (Even if the data input has not been completed, if the data input last has been set, the movement can be confirmed in the same manner.)

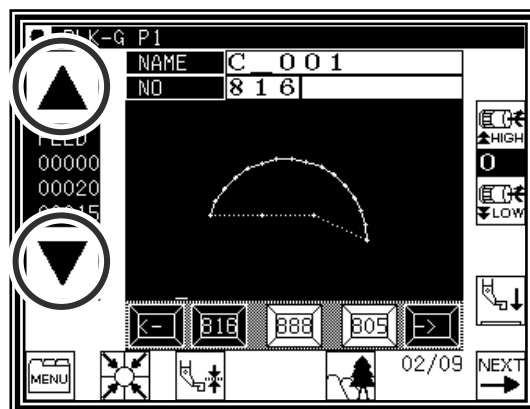
▶ If the data must be modified, refer to section [11] Modification mode Modifying the stitching data.



Memo The size display of the pattern data is explained when "The arc" or "The Circle" is made and the image display  is pushed from a standard screen, the image display screen is opened.

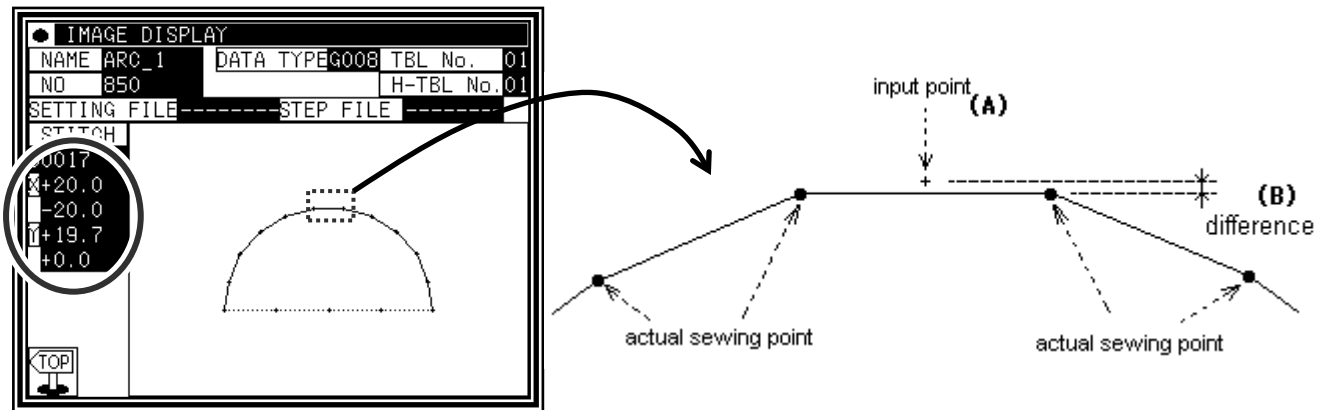

For instance, when made the 20mm half circle data but the size display is not [20.0] Y axially, is [19.9] it like the above figure.

The reason for this is that the displayed value is calculated with an actual sewing point. Tries to make the circle or the circular arc which passes input point as shown in the figure below, the data is made according to the specified stitch length, it is not match that sewing point and input point (A). There is difference (B) of the figure below because the value is calculated with the sewing point.

3.Circle input

Operation points

- Designate circle input ()
- Input three points (A circle, passing through the current position (already input) and two newly input points, is created.)

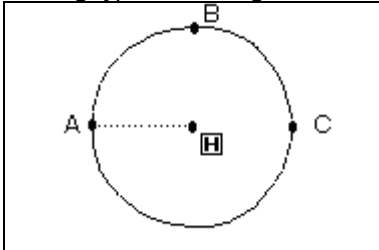

Caution Note that the work holder will go back to the circle start position after the data is created.

[Example] The following type of sewing data will be created.





Operation details

(1)Inputting feed data to A point

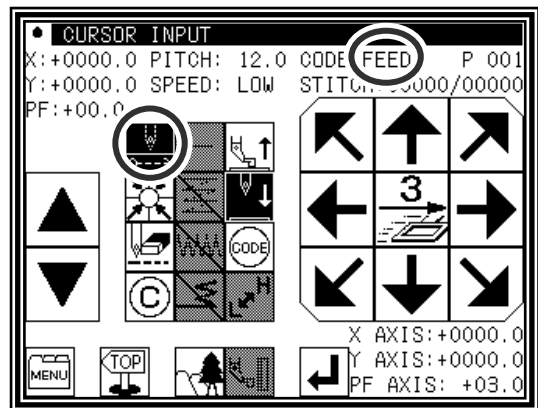
- ▶ Press  and  on the Standard screen. After making the various settings on the Data Setting Input screen, the Arrow Input screen will open. (Refer to Page[6]-2)
- ▶ Check that the code is set to FEED. If different code is set, press  and set the code to FEED.
- ▶ Press the arrow icons and move to the A point. (Feed data to A point.)



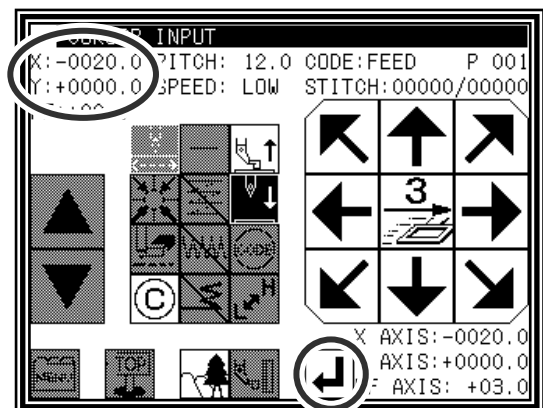

(2)Setting feed data to A point

- ▶ The movement amount can be confirmed.
- ▶ Press  to set the data. (Data on feed data to point A will be created.)
- ▶ To change the stitching type to "Circle input", press the input method setting icon. (In this case, the  icon.)



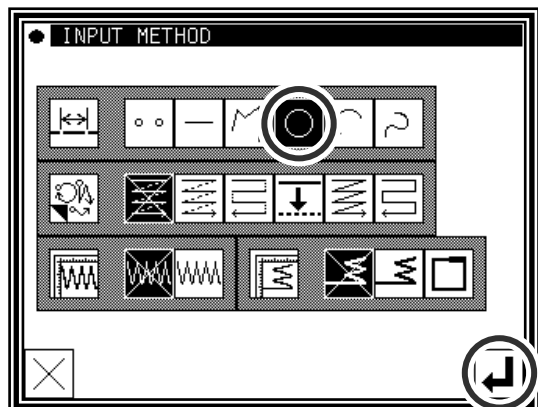

(3)Designating circle input

- ▶ Press .
- ▶ Press  and set the data.
- ▶ The system will return to the arrow input screen.



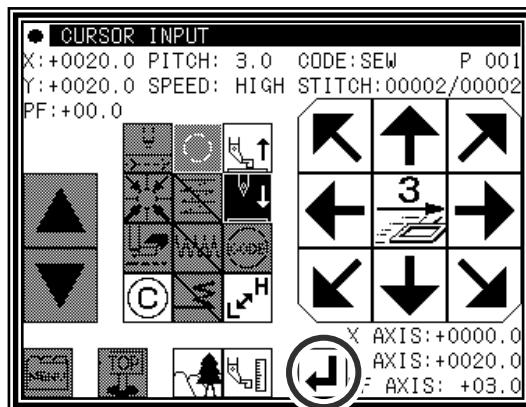

(4) Setting B point and C point

- ▶ Using the arrow icons, move to the B point.
- ▶ Press  to determine point B.
- ▶ The Arrow Input screen will reappear, so press the arrow icons and move to the C point.
- ▶ Press  to determine point C.



(5) Creating the circle input data

- ▶ The confirmation message "Create circle" will appear.
- ▶ Press  to return to the point C data entry panel.
- ▶ Press  and start creation of the circle input data.
- ▶ A message indicating that the data is being created will appear.

Caution Note that the work holder will move to the current position after the data is created.

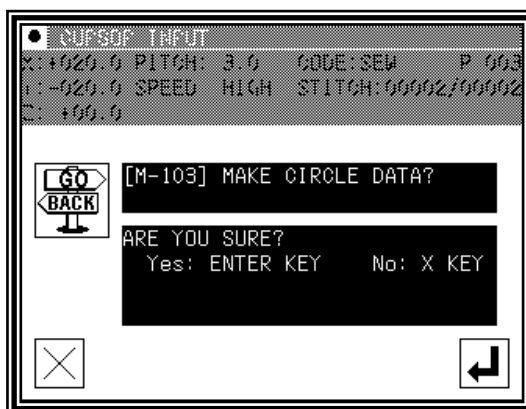

(6) Completing circle input

- ▶ Press .

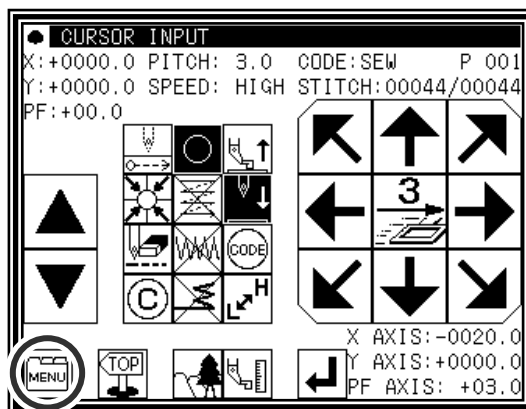

(7) Inputting the return/end code

▶ Press  .

(Data on feed data to the home position and the end code will be created.)

Caution The work holder will automatically return to the home position. Take care when the needle is lowered, etc.

▶ A prompt for home position return will appear.

Press  .

Caution The needle will rise to the UP position. If the needle is not at the UP position, it may lower once and then return to the UP position.

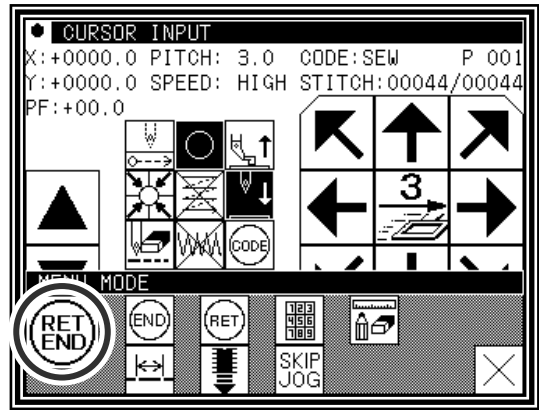

(9) Select a saving method.



▶ After selecting the saving method, press  icon.

(Refer to section [5] Reading, writing and erasing data.)

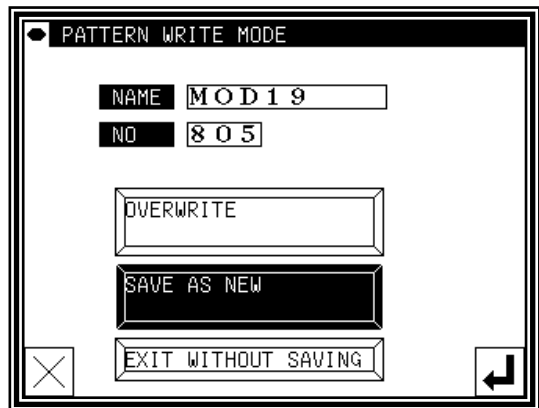
▶ Return to the standard screen.



(10) Confirming the data

▶ Confirm the data. Press the jog icons ( ) so the sewing machine movement can be confirmed. (Even if the data input has not been completed, if the data input last has been set, the movement can be confirmed in the same manner.)

▶ If the data must be modified, refer to section [11] Modification mode Modifying the stitching data.

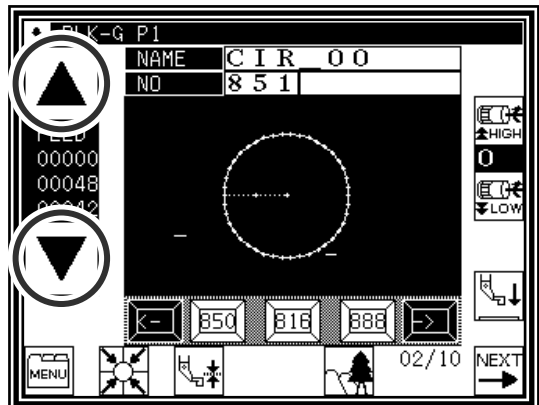

4. Curve input

Operation points

- Designate curve input ()
- Up to 300 points can be input (A curve, passing through the current position and the input points, is created.)
- A delimiter point can be inserted at a pointed corner to continuously input the curve.

[Example] The following type of sewing data will be created.

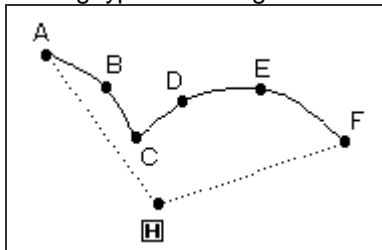



A delimiter is set at the C point.

[Memo] Set the stitch length between 0.1 to 10.0mm.



Operation details

(1) Inputting feed data to A point

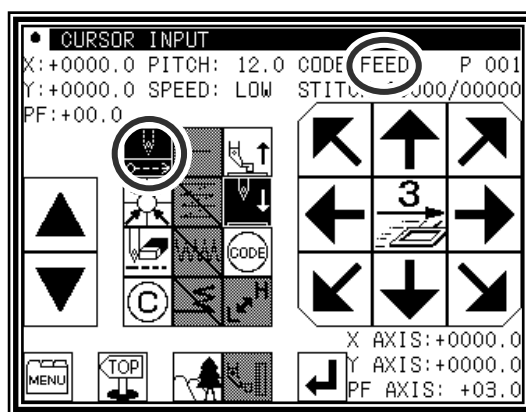
- ▶ Press  and  on the Standard screen. After making the various settings on the Data Setting Input screen, the Arrow Input screen will open. (Refer to Page[6]-2)
- ▶ Check that the code is set to FEED. If different code is set, press  and set the code to FEED.
- ▶ Press the arrow icons and move to the A point. (Feed data to A point.)



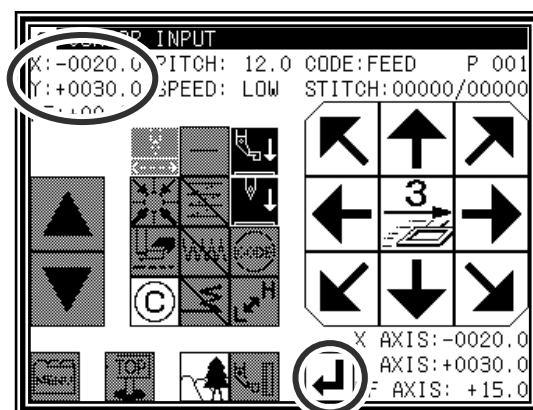

(2) Setting feed data to A point

- ▶ The movement amount can be confirmed.
- ▶ Press  to set the data. (Data on feed data to point A will be created.)
- ▶ To change the stitching type to "CURVE INPUT", press the input method setting icon. (In this case, the  icon.)



(3) Designating curve input

- ▶ Press .
- ▶ Press  and set the data.
- ▶ The system will return to the arrow input screen.

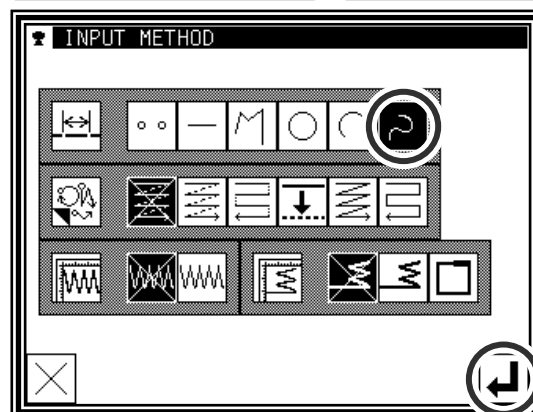

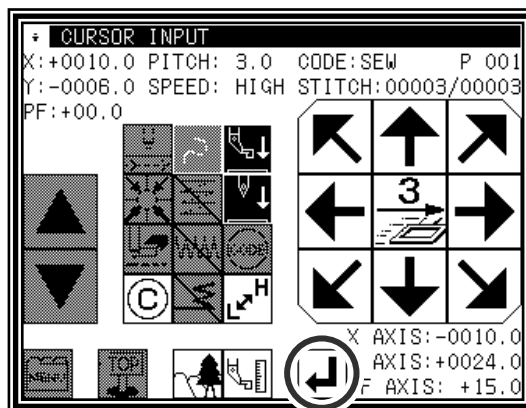

(4) Setting B point

- ▶ Press the arrow mark icon to move to point B.
- ▶ Press  to determine point B.



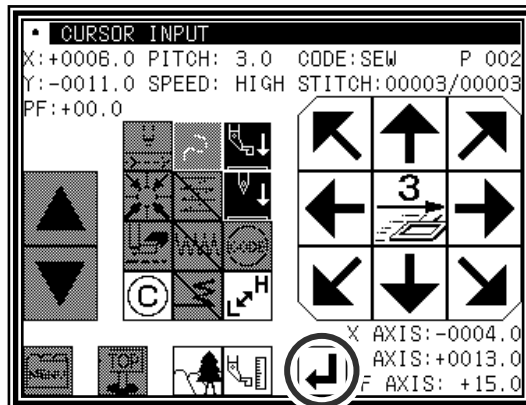

(5) Setting C point

- ▶ Press the arrow mark icon to move to point C.
- ▶ Press  to determine point C.
- ▶ Press  again to enter the breakpoint.





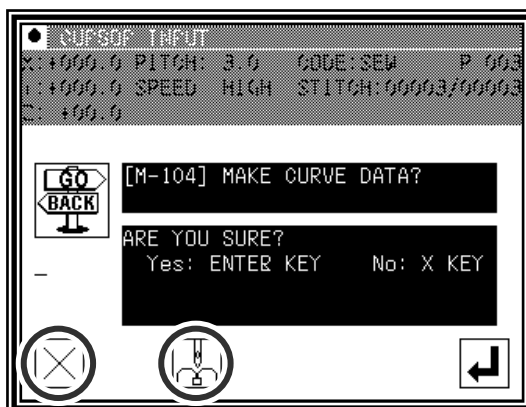

(6) Inserting a delimiter point

- ▶ The data creation confirmation message "Create breakpoint data" will appear.
- ▶ Press  to return to the point C data entry screen.
- ▶ Press . The breakpoint will be set here.



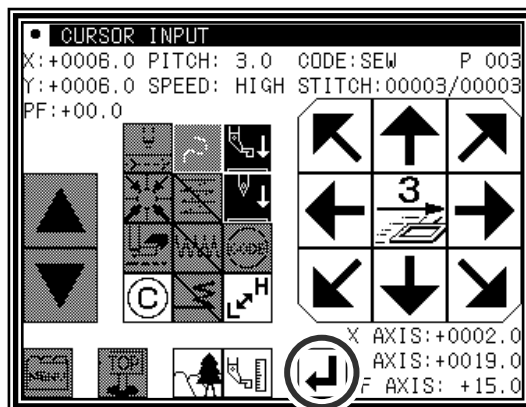

(7) Setting the D point, E point and F point, and setting the curve input

- ▶ The Arrow Input screen will reappear.
- ▶ Press the arrow icons, and move to the D point.
- ▶ Press  to determine point D.
- ▶ Press the arrow icons again, and move to the E point.
- ▶ Press  to determine point E.
- ▶ Press the arrow icons again, and move to the F point.
- ▶ Press  to determine point F.
(Up to 300 points can be input.)
- ▶ At the completion of all point data entry, press  again to create data.



(8)Creating the curve input

- ▶ The data creation confirmation message "Create breakpoint data" will appear.
- ▶ Press  to return to the last point input screen.
- ▶ Press  to start creation of the curve input data.
- ▶ A message indicating that the data is being created will appear.

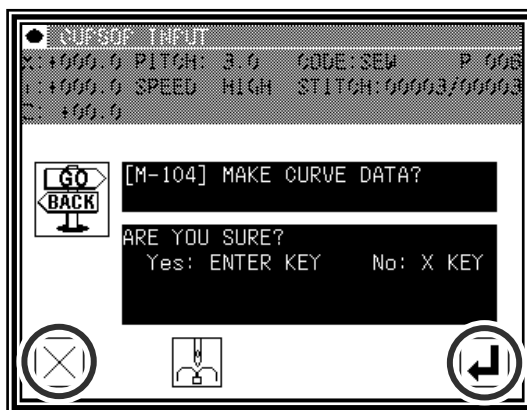

(9)Completing curve input creation

- ▶ Press  .

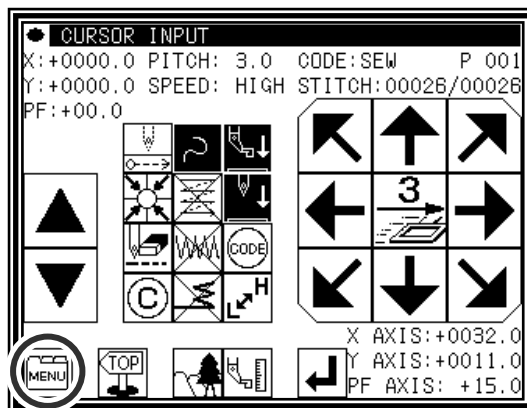

(10)Inputting the return/end code

- ▶ Press  .

(Data on feed data to the home position and the end code will be created.)

Caution The work holder will automatically return to the home position. Take care when the needle is lowered, etc.

- ▶ A prompt for home position return will appear.

Press  .

Caution The needle will rise to the UP position. If the needle is not at the UP position, it may lower once and then return to the UP position.

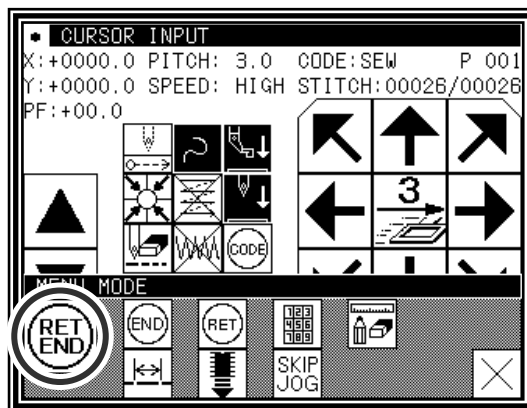

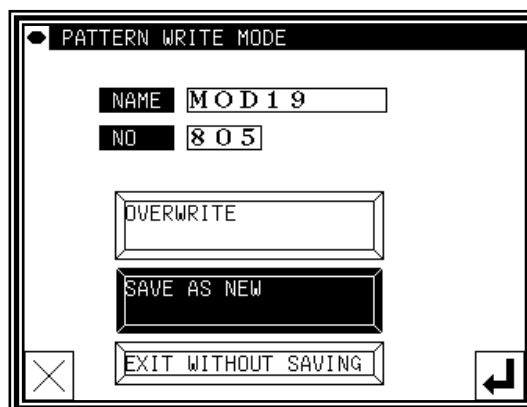

(11)Select a saving method.

- ▶ After selecting the saving method, press  icon.
- (Refer to section [5]Reading, writing and erasing data.)
- ▶ Return to the standard screen.



(12)Confirming the data

- ▶ Confirm the data. Press the jog icons ( ) so the sewing machine movement can be confirmed. (Even if the data input has not been completed, if the data input last has been set, the movement can be confirmed in the same manner.)
- ▶ If the data must be modified, refer to section [11] Modification mode Modifying the stitching data.

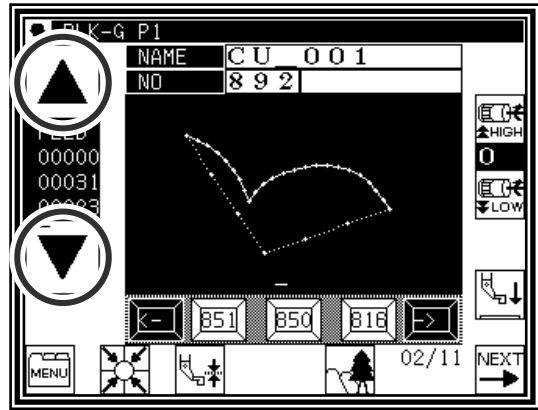

Memo If the distance between the curve start point and the end point is less than 0.5 mm, the pattern will be regarded as the "closed pattern", and the same coordinate value will be automatically set for both the start point and end point.

Precautions for inputting a curve

- ▶ For shape data as shown below, continuous curve input is possible by selecting a delimiter point where the corner is pointed (K point). (This can also be applied for noncontinuous points such as for offset stitching, multiple stitching, and reverse multiple stitching.)

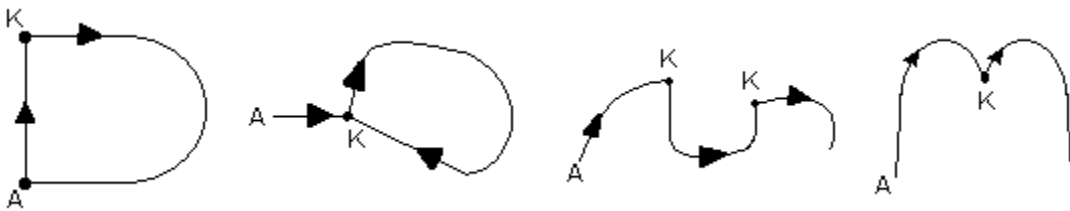

5. Broken line input

Operation points

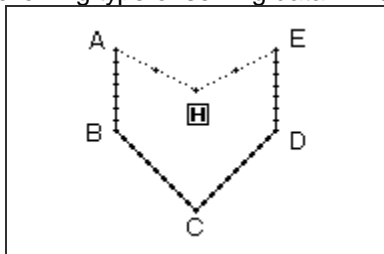

- Designate broken line input()
- Up to 300 points can be input (A broken line connecting the current position and input points is created.)

[Example] The following type of sewing data will be created.





Operation details

(1) Inputting feed data to A point

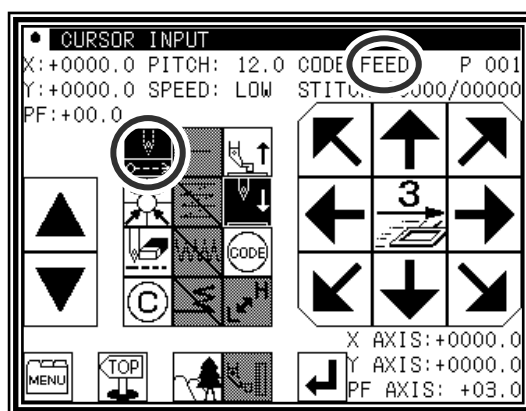
- ▶ Press  and  on the Standard screen. After making the various settings on the Data Setting Input screen, the Arrow Input screen will open. (Refer to Page[6]-2)
- ▶ Check that the code is set to FEED. If different code is set, press  and set the code to FEED.
- ▶ Press the arrow icons and move to the A point. (Feed data to A point.)



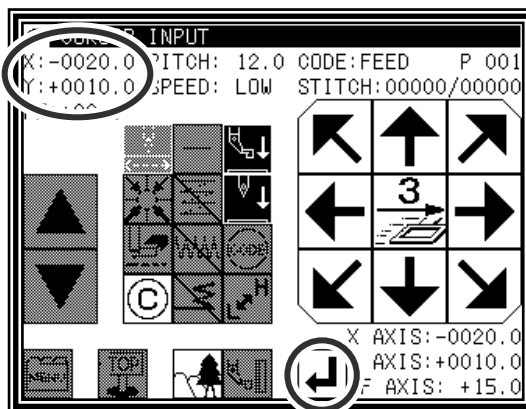

(2) Setting feed data to A point

- ▶ The movement amount can be confirmed.
- ▶ Press  to set the data. (Data on feed data to point A will be created.)
- ▶ To change the stitching type to "Broken line input", press the input method setting icon. (In this case, the  icon.)



(3) Designating broken line input

- ▶ Press .
- ▶ Press  and set the data.
- ▶ The system will return to the arrow input screen.

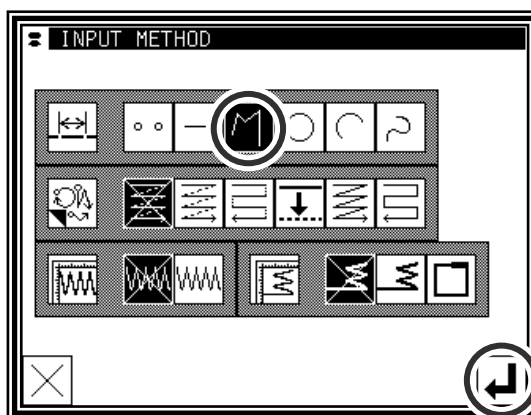

(4) Setting B point , C point , D point , E point

▶ Press the arrow mark icon to move to point B.

▶ Press  to determine point B.

▶ Press the arrow mark icon to move to point C.

▶ Press  to determine point C.

▶ Press the arrow mark icon to move to point D.

▶ Press  to determine point D.

▶ Press the arrow mark icon to move to point E.

▶ Press  to determine point E.

(Up to 300 points can be input.)

▶ At the completion of all point data entry, press  again to create data.

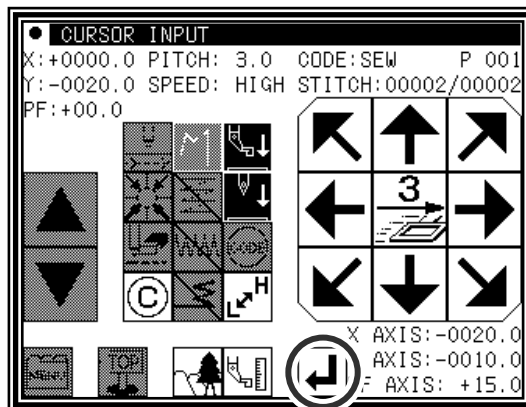

(5) Creating the broken line input

▶ The data creation confirmation message "Create breakpoint data" will appear.

▶ Press  to return to the last point input screen.

▶ Press  to start creation of the broken line input data.

▶ A message indicating that the data is being created will appear. (The broken line will be created.)

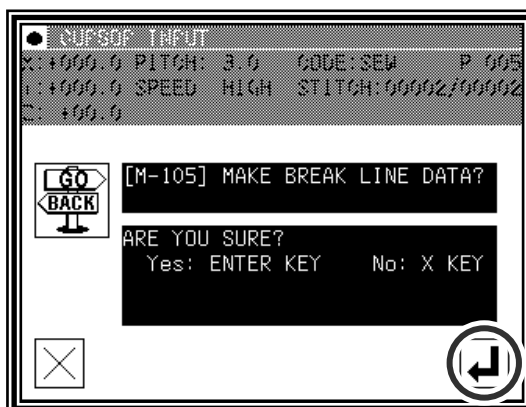

(6) Creating the broken line input

▶ Press .

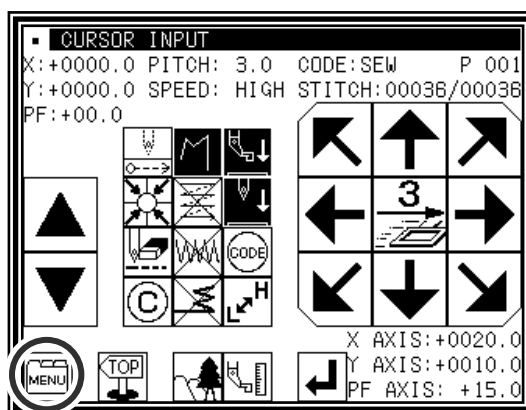

(7) Inputting the return/end code



(Data on feed data to the home position and the end code will be created.)

Caution The work holder will automatically return to the home position. Take care when the needle is lowered, etc.

▶ A prompt for home position return will appear.



Caution The needle will rise to the UP position. If the needle is not at the UP position, it may lower once and then return to the UP position.

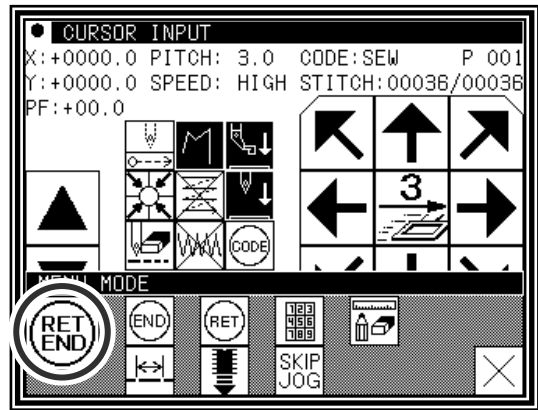

(8) Select a saving method.



▶ After selecting the saving method, press  icon.

(Refer to section [5] Reading, writing and erasing data.)

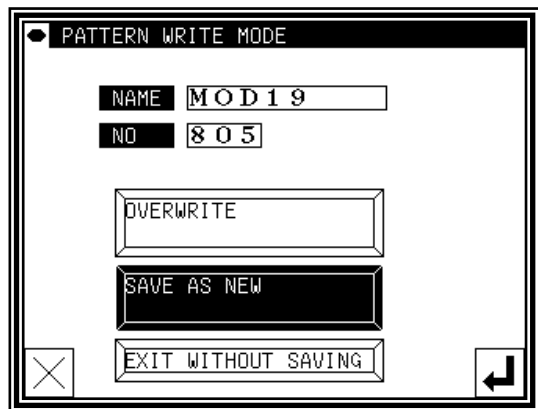
▶ Return to the standard screen.



(9) Confirming the data

▶ Confirm the data. Press the jog icons ( ) so the sewing machine movement can be confirmed. (Even if the data input has not been completed, if the data input last has been set, the movement can be confirmed in the same manner.)

▶ If the data must be modified, refer to section [11] Modification mode Modifying the stitching data.

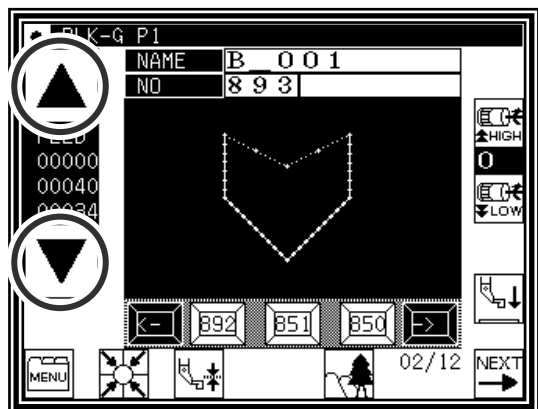

Memo If the distance between the broken line start point and the end point is less than 0.5 mm, the pattern will be regarded as the "closed pattern", and the same coordinate value will be automatically set for both the start point and end point.

6.Point input

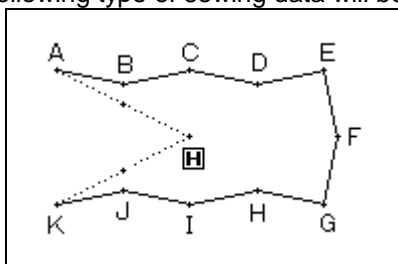

Operation points

- Designate point input()
 (The distance between the points must be within 20mm)
 [Example] The following type of sewing data will be created.





Operation details

(1)Inputting feed data to A point

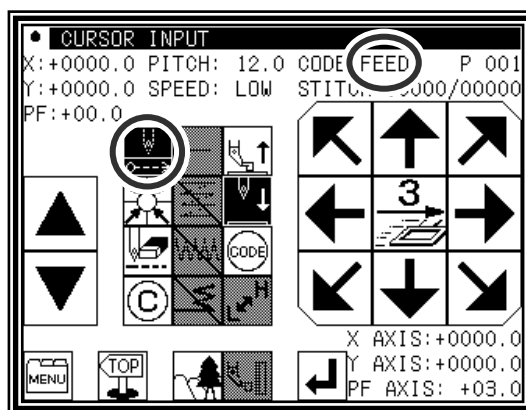
- Press  and  on the Standard screen. After making the various settings on the Data Setting Input screen, the Arrow Input screen will open. (Refer to Page[6]-2)
- Check that the code is set to FEED. If different code is set, press  and set the code to FEED.
- Press the arrow icons and move to the A point. (Feed data to A point.)



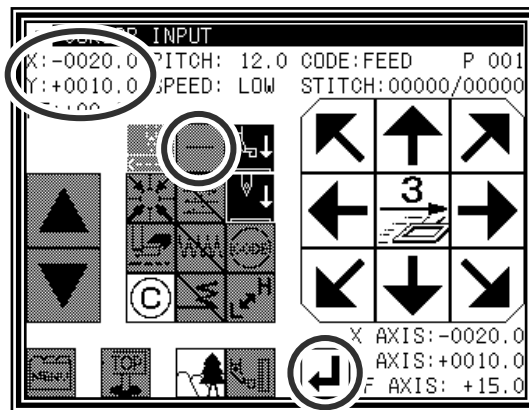

(2)Setting feed data to A point

- The movement amount can be confirmed.
- Press  to set the data. (Data on feed data to point A will be created.)
- To change the stitching type to "POINT INPUT", press the input method setting icon. (In this case, the  icon.)



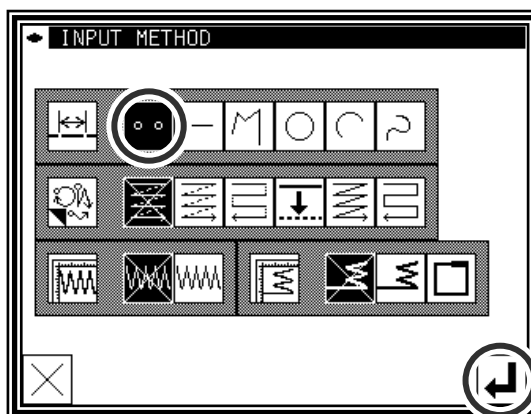

(3)Designating point input

- Press .
- Press  and set the data.
- The system will return to the arrow input screen.



(4) Setting B point to K point

- ▶ Press the arrow mark icon to move to point B.
- Memo** The distance between the points must be within 20mm.
- ▶ Press  to determine point B.
- ▶ Press the arrow mark icon to move to point C.
- ▶ Press  to determine point C.
- ▶ The Arrow Input screen will reappear, so press the arrow icons and move to the D point to K point in the same manner.
- ▶ Press .

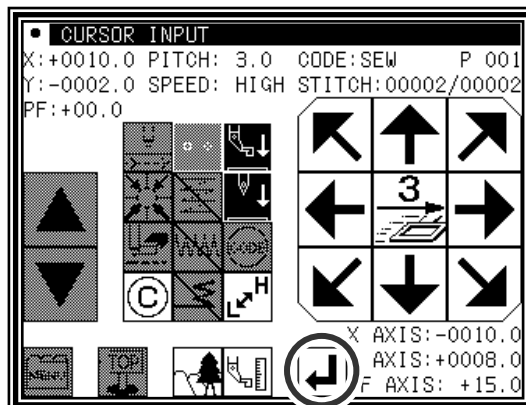

(5) Inputting the return/end code

- ▶ Press .
- (Data on feed data to the home position and the end code will be created.)

Caution The work holder will automatically return to the home position. Take care when the needle is lowered, etc.

- ▶ A prompt for home position return will appear.
- Press .

Caution The needle will rise to the UP position. If the needle is not at the UP position, it may lower once and then return to the UP position.

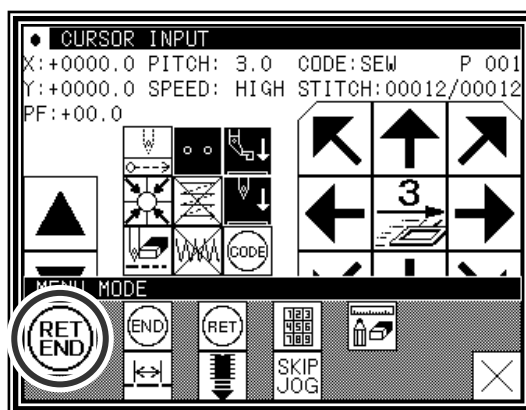

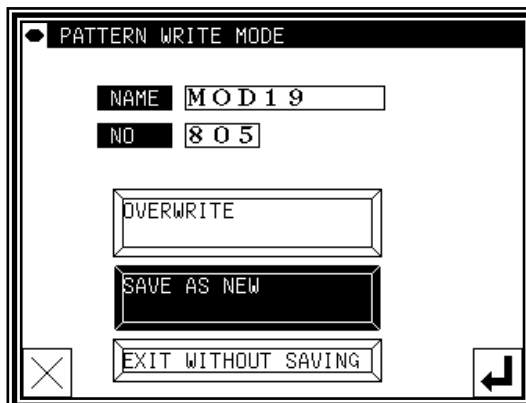

(6) Select a saving method.

- ▶ After selecting the saving method, press  icon.
- (Refer to section [5] Reading, writing and erasing data.)
- ▶ Return to the standard screen.



(7) Confirming the data

- ▶ Confirm the data. Press the jog icons ( ) so the sewing machine movement can be confirmed. (Even if the data input has not been completed, if the data input last has been set, the movement can be confirmed in the same manner.)
- ▶ If the data must be modified, refer to section [11] Modification mode Modifying the stitching data.

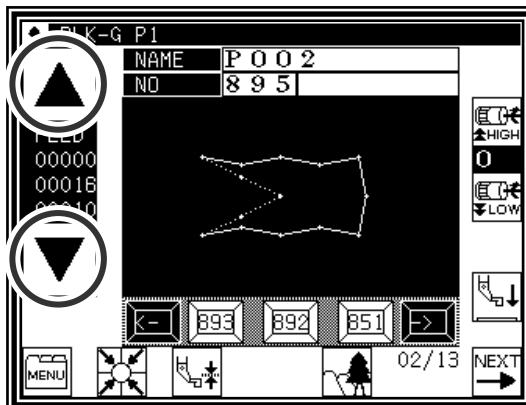

7.Code data input

Operation points

- Designate code data input()
 - Select and input the code data from the code data list
- [Example] The following type of sewing data will be created.

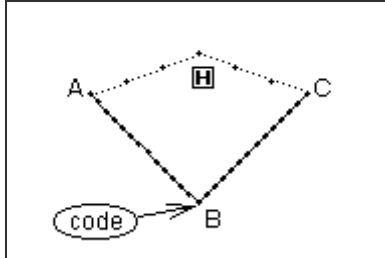

Input the "NEEDLE UP HALT" code at the B point between the A-B point linear line and B-C linear line.

[Memo] Code data cannot be inserted when inputting with a linear, circle, arc, curve or polygonal line. To input, add the code data with the modification mode. (Input between the linear lines is possible as shown in the example.)

Operation details

(1)Inputting a linear line from A point to B point

- ▶ Input a linear line from the A point to B point using the linear input procedures.

(2)Inputting the code data (NEEDLE UP HALT)

- ▶ Press  .

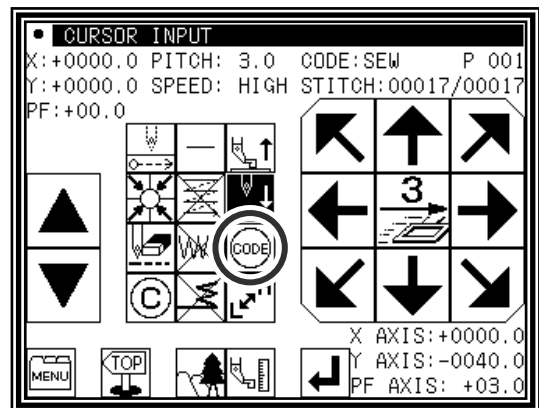

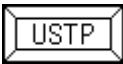
- ▶ Press  .
(Refer to the code list of the next page.)

- ▶ Press  to set the code.
(The "NEEDLE UP HALT" code will be created.)

- ▶ The system will return to the arrow input screen.

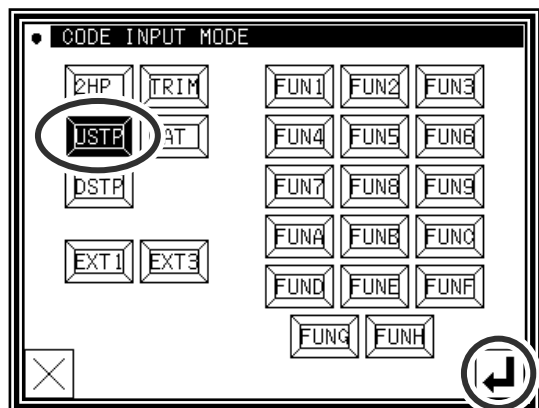

(3)Inputting a linear line from B point to C point

- ▶ Input a linear line from the B point to C point using the linear input procedures.

(4)Inputting the return end and the data completion

- ▶ The return end is input and it is completion.

■List of code data

| Code | Function | Code | Function |
|------|-------------------|------|-----------------|
| 2HP | 2nd home position | FUN1 | Function code 1 |
| USTP | Needle UP halt | FUN2 | Function code 2 |
| DSTP | Needle DOWN halt | FUN3 | Function code 3 |
| TRIM | Thread trimming | FUN4 | Function code 4 |
| BAT | Basting | FUN5 | Function code 5 |
| | | FUN6 | Function code 6 |
| | | FUN7 | Function code 7 |
| | | FUN8 | Function code 8 |
| | | FUN9 | Function code 9 |
| | | FUNA | Function code A |
| | | FUNB | Function code B |
| | | FUNC | Function code C |
| | | FUND | Function code D |
| | | FUNE | Function code E |
| | | FUNF | Function code F |
| | | FUNG | Function code G |
| | | FUNH | Function code H |

| |
|--|
| EXT1 : Extension code ASRT : Automatic start after stopping |
| EXT3 : Extension code F1_H~FH_H : FN (1~H) Output ON F1_L~FH_L : FN (1~H) Output OFF |

Making method of using BAT (Basting or more than 20mm stitch length) code.

The sewing data which exceeds the stitch length limitation of 20mm can be made by using this BAT code.

[Example] The following type of sewing data will be created.

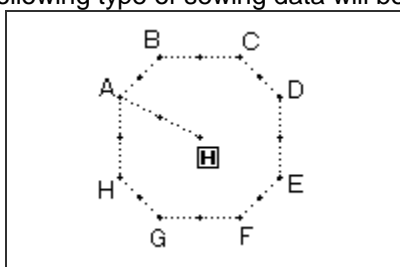

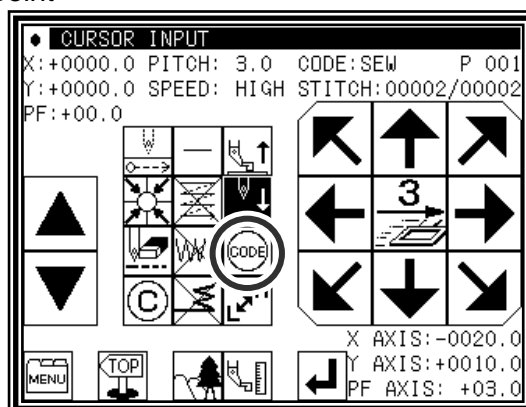

(1) Input the "BAT" codes after input the feed data to A point

► Press  .

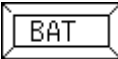

(2)Code selection on code selection screen

- ▶ Press  .
- ▶  decides to pushing.
(The BAT code is made.)
- ▶ Returns to the arrow input screen.

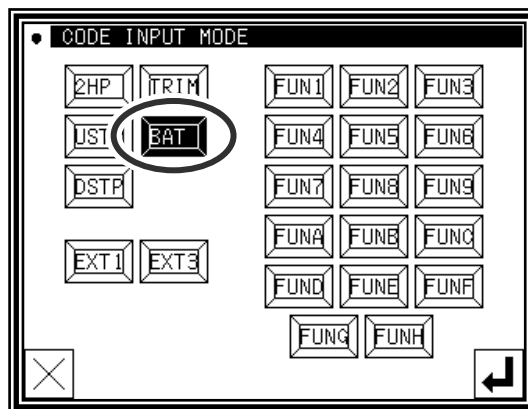

(3)Arrow input screen

- ▶ Does not become SEW (Sewing) input mode and it is FEED input mood after input the "BAT" code.
- ▶ Input the feed data to the next B point.
- ▶ Input the "BAT" code and the feed data from H point to A point repeating.

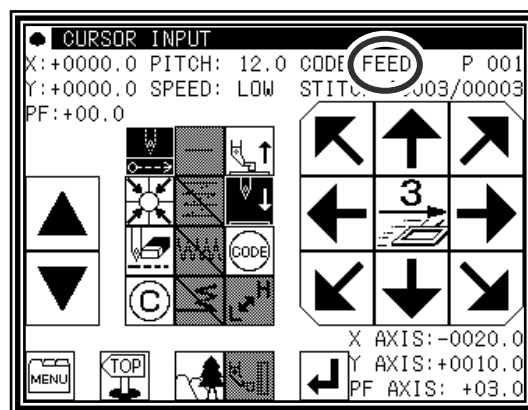

(4)The pattern data input before return end

- ▶ It is not input the "BAT" code before the last of return end but the sewing data is input. Inputs here only by 1 stitch of the straight line.

Memo The purpose of inputting the sewing data at the end is to put the thread trimmer (TRIM) code by the automatic operation when the return end is input. The thread trimmer(TRIM) code cannot be input after the sewing data.

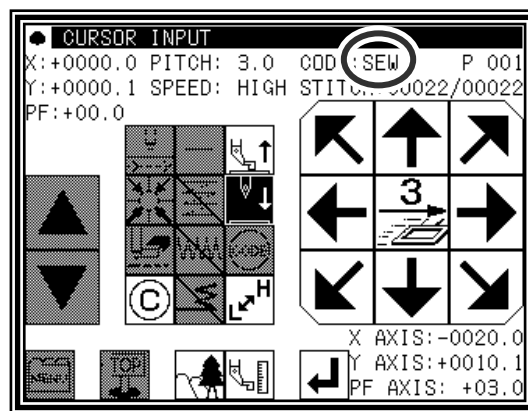

(5)Input the return end and the data completion

- ▶ The return end is input and it is completion.

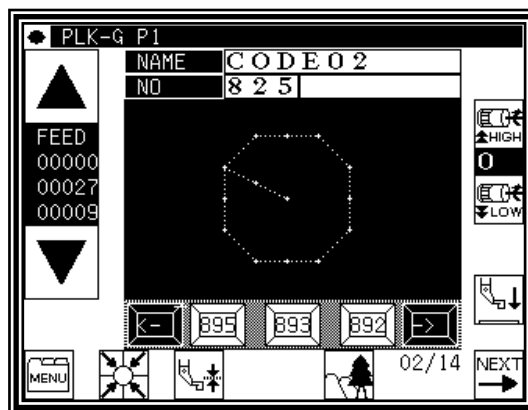

About Extension code 1 (EXT1)

* Press the Extension screen display key , and press .

- ▶ "ASRT" : Automatic start after stopping
Using the numeric keypad, set the time that stops until starting automatically.

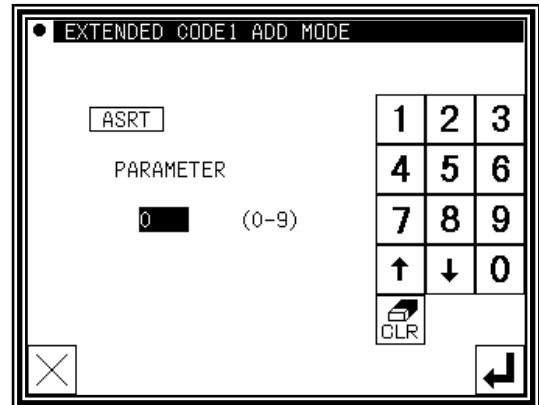

About the Function code (FUN1~FUNH)

Output signal FN1 to FNH can be controlled by set in the pattern data. (Refer to P.[14]-9)

When code data FUN1 is read in the pattern data while sewing, FN1 output is reversed.
(same as FUN2~FUNH)



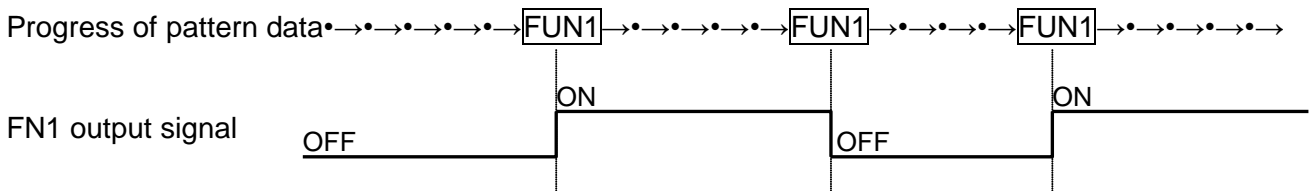





[example. Timing chart when FUN1 code is set in the pattern data]



⚠ Caution PLEASE DO NOT MIX F1_H~FH_H or F1_L~FH_L code with FUN1~FUNH code in the same data.

Application inputs

Various types of stitching, including back tacking, multiple stitching, offset stitching and zigzag stitching can be carried out. Various types of stitching data can be created by combining the basic inputs and these types. (Refer to section [9] Table of stitching type combinations.) Note that the application inputs cannot be combined with point inputs to input data.

| Function | icon | |
|--------------------------------|--|--|
| Back tacking ([7]-25) |  Start/end back tacking | |
| |  Overlap back tacking | |
| Multiple stitching ([7]-29) |  Multiple stitching (Feed data specifications) |  Multiple stitching (stitching specifications) |
| |  Reverse multiple stitching (Feed data specifications) |  Reverse multiple stitching (stitching specifications) |
| Offset stitching ([7]-32) |  | |
| Zigzag stitching ([7]-34) |  | |

8.Back tacking (start/end back tacking)

[Example] The following type of sewing data will be created.

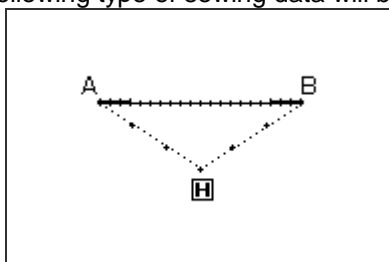



With the linear input, the N mode and 3-stitch back tacking will be inserted for both the start and end of stitching. (The bold sections indicate start/end back tacking.)

Operation details

(1)Setting the input method

▶ Set the feed data from the home position to the A point with the procedures for linear input, and open the Input Method Setting screen.

▶ Press Linear Input  .

▶ Press back tacking  .

▶ Press the back tacking details setting icon  .

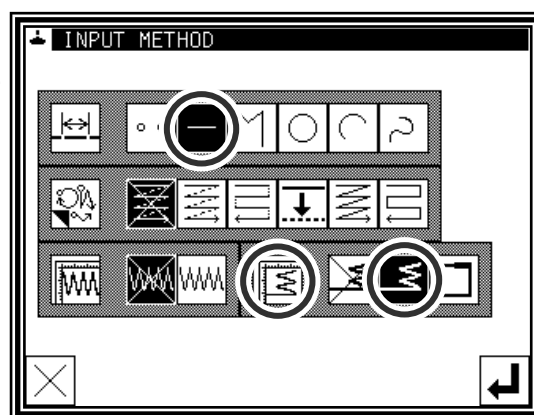



(2) Setting the back tacking details

- ▶ The details are set on this screen.

(The details set here are,

 (start/end back tacking),

start mode  (N mode), three start stitches,

end mode  (N mode), three end stitches.)

- ▶ Press  to determine these set values.

- ▶ The system will return to the input method setting screen.

- ▶ Press  to determine the set values.

- ▶ The system will return to the arrow input screen.

- ▶ Determine the B point with the linear input procedures, and create a linear line.

- ▶ After creating the linear line, press .

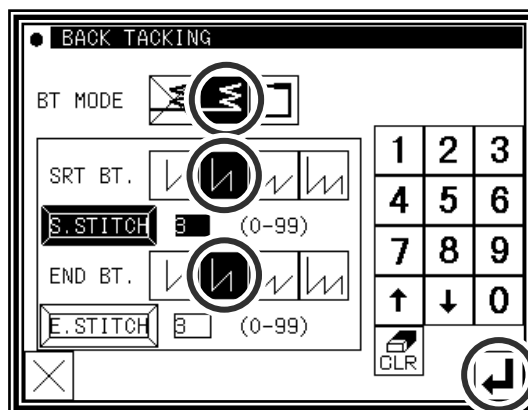

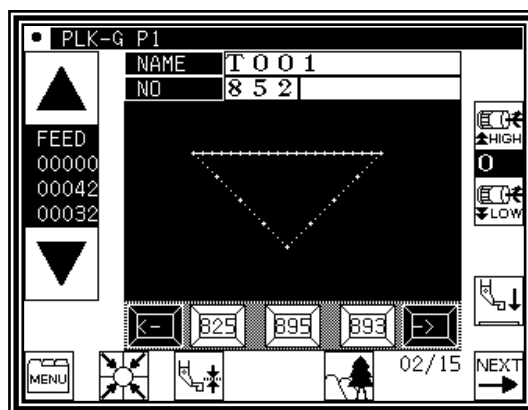

(3) Confirming the data

- ▶ The start/end back tacking data for the linear line has been created.



Memo Regarding back tacking mode

 V mode: Back tacking will be performed only once.



 N mode: Back tacking will be performed twice.

 M mode: Back tacking will be performed third.

 W mode: Back tacking will be performed fourth.

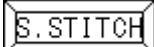
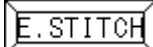
Memo Regarding number of stitches

Press the icon of the desired position ( or ) to invert the icon.

After that, set data using the numeric icons or  .

Memo Press the back tacking data setting icon on the arrow input screen to directly display the "detailed back tacking data setting" screen.

9. Back tacking (overlap back tacking)

[Example] The following type of sewing data will be created.

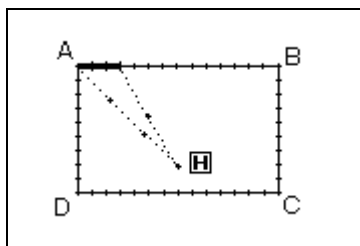



Input a rectangle as a broken line, and then insert overlap back tacking at the end. (The overlap mode is entered once; three overlap stitches are made.) (The bold section is the overlap back tacking section.)

Memo It is a shutting figure in the figure made in [Broken line], [Circle], [Curve] to be able to do multiple back tacking. That is, it is not possible to do by combining "Straight line" in the plural in the enclosed figure. Moreover, it is not possible to do by plural combining "Straight line" and "Curve" also even in the enclosed figure. The multiple back tacking can be made only by 1 place per 1 "Sewing" data origination.



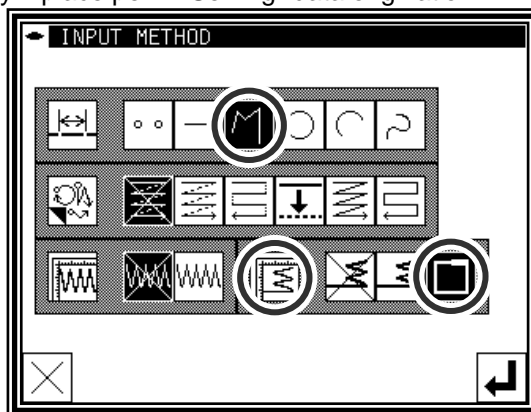

Operation details

(1) Setting the input method

- ▶ Set the feed data from the home position to the A point with the procedures for broken line input, and open the Input Method Setting screen.
- ▶ Press broken Line Input .
- ▶ Press Overlap back tacking .
- ▶ Press the back tacking details setting icon .



(2) Setting the back tacking details

- ▶ The details are set on this screen. (The details set here are,  (overlap back tacking), overlap mode , three overlap stitches.)
- ▶ Press  to determine these set values.
- ▶ The system will return to the input method setting screen.
- ▶ Press  to determine the set values.
- ▶ The system will return to the arrow input screen.
- ▶ Determine the B, C, D and A points with the broken line procedures, and create the broken line data. (A broken line having overlap back tacking will be created.)
- ▶ After creating the broken line data, input .

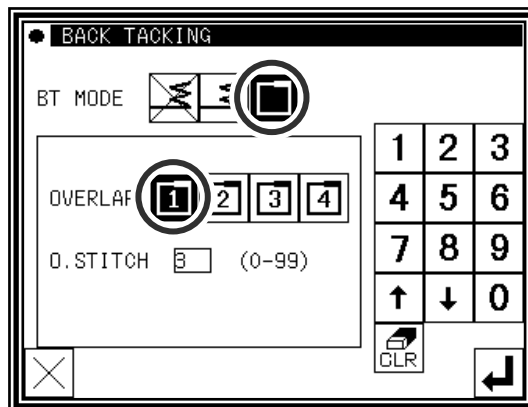

(3) Confirming the data

- ▶ The overlap back tacking will be created with the rectangle made with broken lines.

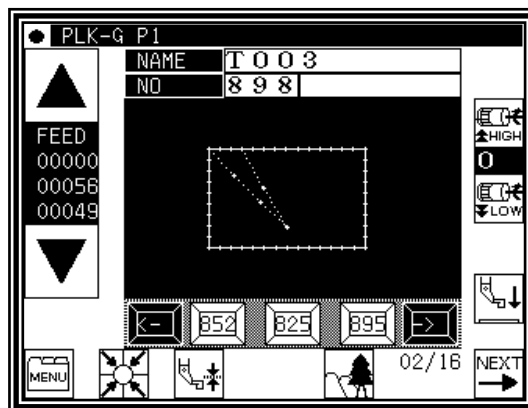

Memo Overlap mode

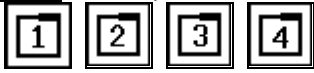

in the overlap mode indicate the number of overlapped sections.

Memo Number of overlap stitches

This is the number of stitches at the overlapped section. (Set a value between 0 and 99.)

Memo If the distance between the broken line start point and the end point is 0.5 mm or more, the overlap back tacking data will not be created. (If the distance between the broken line start point and the end point is less than 0.5, the pattern will be regarded as the "closed pattern", and the same coordinate value will be automatically set for both the start point and end point.)

10. Multiple stitching

| Type | Connection | icon | Stitching data image | Explanation |
|------------------|------------|------|----------------------|--|
| Multiple | Feed data | | | "Stitching" in a set direction is connected with "feed without stitching". |
| | Stitching | | | "Stitching" in a set direction is connected with "stitching". |
| Reverse multiple | Feed data | | | "Stitching" in alternating reverse directions is connected with "feed data". |
| | Stitching | | | "Stitching" in alternating reverse directions is connected with "stitching". |

{
 and (dotted line) in the image indicates "feed data".
 and (solid line) in the image indicates "stitching".
 }

[Example] The following type of sewing data will be created.

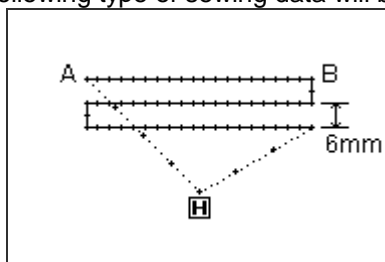

Create the linear reverse multiple (stitching specification) data.
 (The multiple distance is 6mm, the number of times is three, the direction is right.)

Operation details

(1) Setting the input method

▶ Set the feed data from the home position to the A point with the procedures for linear input, and open the Input Method Setting screen.

▶ Press Linear Input

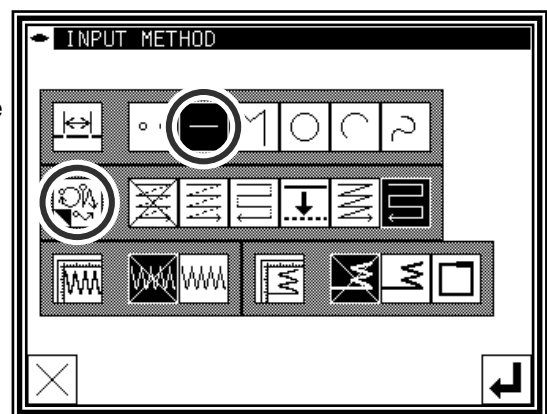

▶ Press Reverse Multiple (stitching specifications)

▶ Press the reverse multiple details. Press



(2) Setting the reverse multiple stitching details

- ▶ The details are set on this screen.

(Press  and , and set the distance to 6.0, and the number of times to 3.)

- ▶ Press  to set the data.

- ▶ The system will return to the input method setting screen.

- ▶ Press  to set the data.

- ▶ The system will return to the arrow input screen.

- ▶ Determine the B point with the linear input procedures, and create a linear line. (A straight line having reverse multiple (stitching specification) will be created.)

- ▶ After creating the linear line, input .

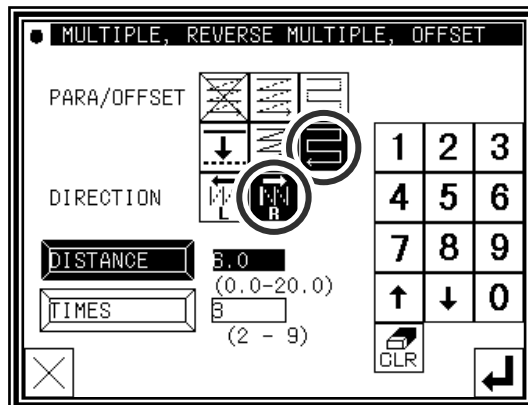

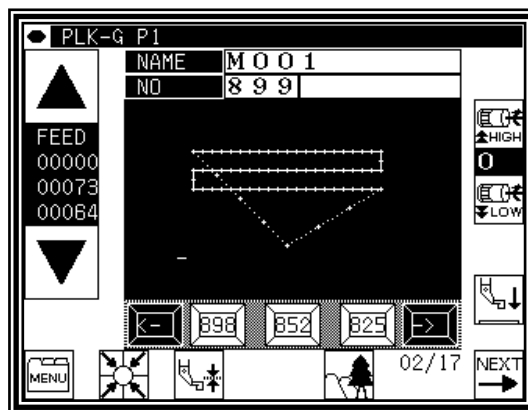

(3) Confirming the data

- ▶ Linear reverse multiple data has been created.



Memo Direction

When creating multiple stitching to the left of the input stitching line, press  (left side).

When creating multiple stitching to the right of the input stitching line, press  (right side).

Memo Distance

This is the distance between the multiple stitching and adjacent line. Set between 0.0mm and 20.0mm. To input the distance data, press the DISTANCE icon to invert the icon. After that, input the data using the numeric icons or the up/down arrow mark icons.

Memo Number of times

Set the number of multiple stitching layers. Set between 2 and 9. To input the number of times, press the NUMBER OF TIMES icon to invert the icon. After that, input the data using the numeric icons or the up/down arrow mark icons.

Memo Or press the MULTI, REVERSE MULTI, OFFSET icon on the arrow input screen to directly display the MULTI, REVERSE MULTI, OFFSET setting screen.

Memo (A) It is for the combination data of a curve input and multiple (offset) sew.

The data like the figure below (right) is made as shown in the figure below (left) when curves which pass point 2, point 3, and point 4 after an feed from the home position to point 1 are combined with multiple sewing and inputs. (Distance=10mm and 2 times of "Frequency")
The distance of the multiple data becomes "It is narrow" the data as shown in figure.

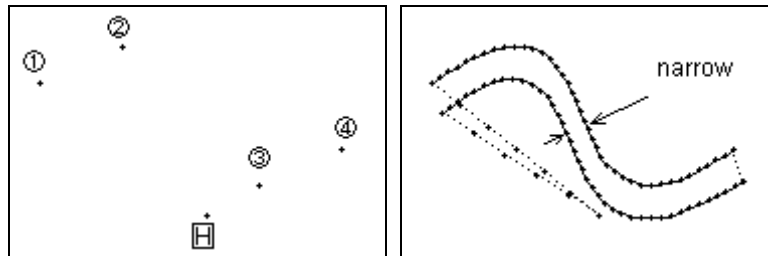

They are not like to make this partially narrow multiple data, to make a constant distance multiple data as much as possible, please input 2' between 2 and 3 as shown in the figure below (left). The multiple data as shown in the figure below (right) is made.

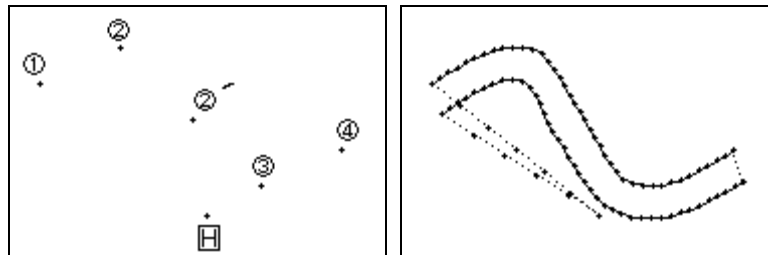

Memo (B) It is for the combination data of a curve input (Broken line input) and multiple sew.

The data like the figure below (right) is made as shown in the figure below (left) when curves which pass point 2, point 3, and point 4 after an feed from the home position to point 1 are combined with multiple sewing and inputs. (Distance=8mm and 4 times of "Frequency")

The data is made in the curve that the fourth curve is different as understood from figure(right).

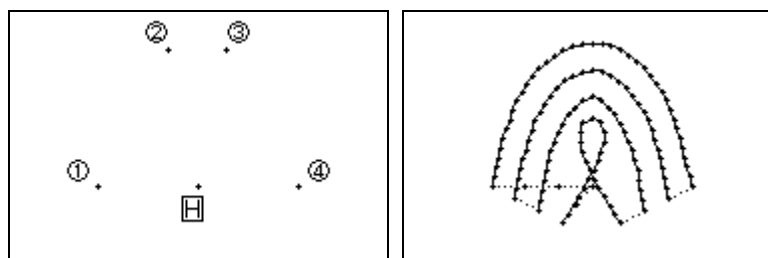

When the virtual input point which makes the multiple is requested by the operation, such a situation like the figure below, the reason for it is to intersect in the multiple.

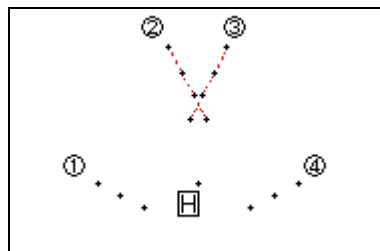

Moreover, such a situation changes variously depending on the condition of the input point etc. of "Distance", "Frequency" of the multiple data, and the curve.
Please use a variety of trying.

11. Offset stitching (with overlap back tacking)

[Example] The following type of sewing data will be created.

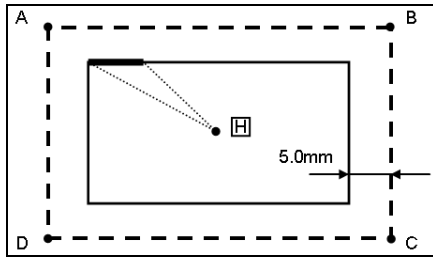

Input offset stitching with overlap back tacking as a broken line. (Set the offset distance to "5.0 mm", direction to "right", overlap back tacking mode to "1", and number of stitches to "3".)

(The bold section indicates the overlap back tacking section.)

(The dotted line (- - - - -) indicates the actual input line (position before offset.)

Operation details

(1) Setting the input method

▶ Set the feed data from the home position H to the A point with the procedures for broken line input, and open the Input Method Setting screen.

▶ Press Broken Line Input .

▶ Press Offset .

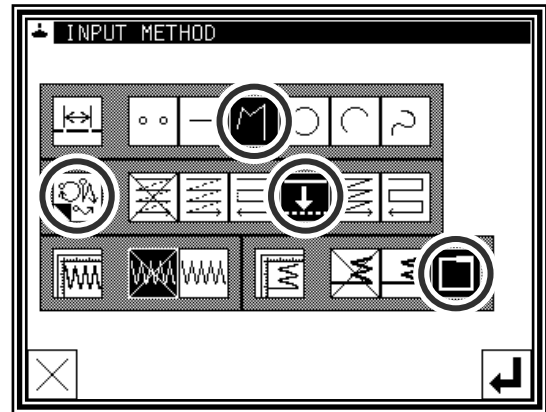

▶ Press Overlap Back Tacking .

▶ Set the application input details. Press .



(2) Setting the offset details

▶ The details are set on this screen.

(Press  , and set the distance to 5.0.)

The offset amount can be set in 0.1mm increments between 0 and 20mm.

▶ After inputting the details, press  to set the data.

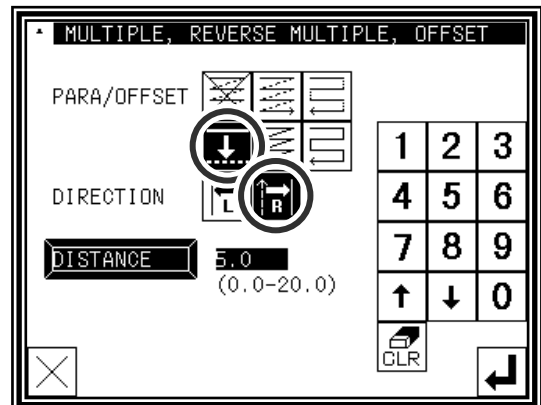

(3) Setting the back tacking details

▶ After returning to the Input Method Setting screen, press the back tacking details setting icon .

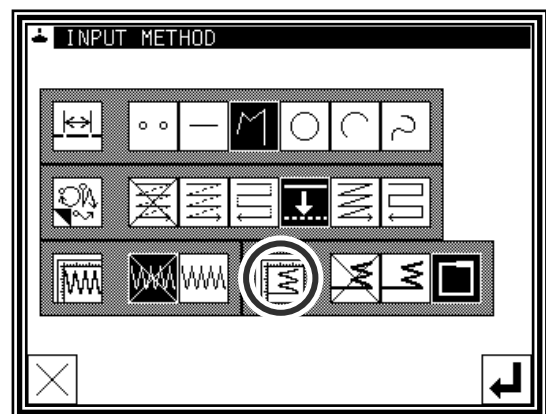

(4) Setting the overlap back tacking details

- ▶ The details are set on this screen.

(The details set here are,  (overlap back tacking),

overlap mode , three overlap stitches.)

- ▶ Press  to set the data.

- ▶ The system will return to the input method setting screen.

- ▶ Press  to set the data.

- ▶ The system will return to the arrow input screen.

- ▶ Determine the B, C D and A points with the broken line procedures, and create the broken line data.

- ▶ After creating the broken line data, input .

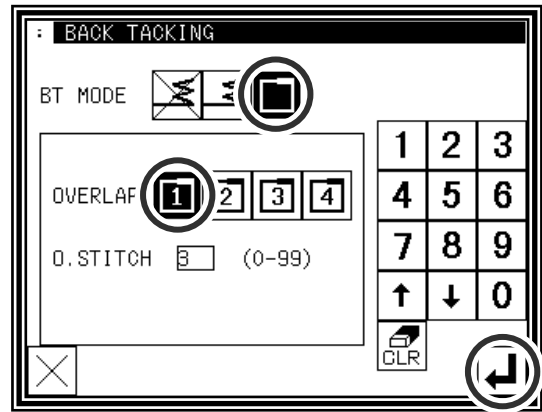

(5) Confirming the data

- ▶ The offset data will be displayed on the image screen.

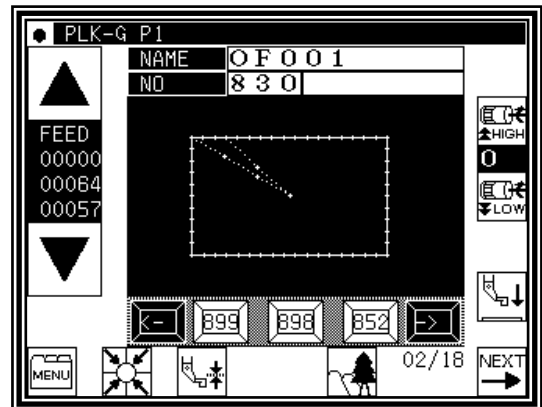

- ▶ **Memo** Or press the MULTI, REVERSE MULTI, OFFSET icon on the arrow input screen to directly display the MULTI, REVERSE MULTI, OFFSET setting screen.

12.Zigzag stitching (with overlap back tacking)

[Example] The following type of sewing data will be created.

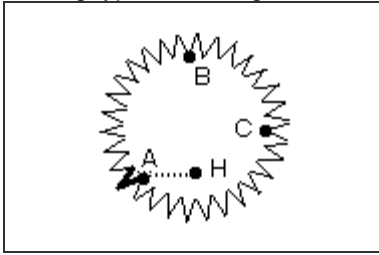

Input zigzag stitching with overlap back tacking as circle. (The zigzag deflection width will be 5.0mm, the feed amount will be 3.0mm, the direction is left, the overlap back tacking mode will be carried out once, and three overlap stitches will be made.)

(The bold section is the overlap back tacking section.)

Operation details

(1)Setting the input method

▶ Set the feed data from the home position H to the A point with the procedures for broken line input, and open the Input Method Setting screen.

▶ Press Circle  .

▶ Press Zigzag  .

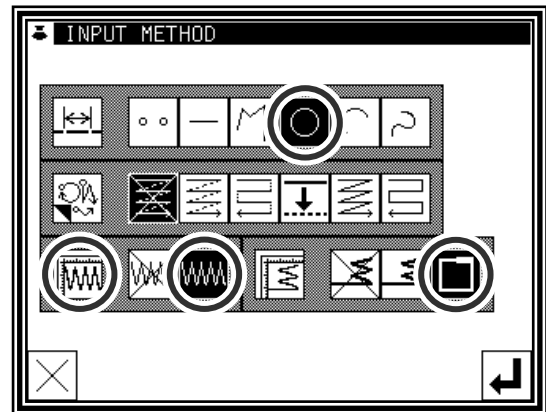

▶ Press Overlap Back Tacking  .

▶ Set the zigzag details. Press  .



(2)Setting the zigzag details

▶ The details are set on this screen.

(Press  , set the deflection width to 5.0, feed amount to 3.0 and direction to "left"  .)

(The zigzag deflection width can be set in 0.1mm increments between 0.2 and 19.0mm.)

(The zigzag feed amount can be set in 0.1mm increments between 0.2 and 10.0mm.)

(Refer to the "Deflection width, feed amount and creation direction" section given later for details.)

▶ After inputting the details, press  to set the data.

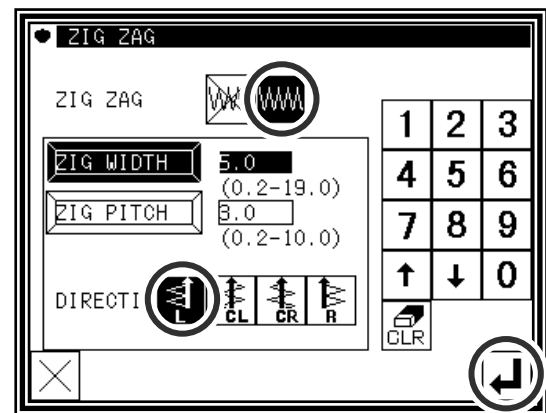

Memo To input the stitch width/length, press the STITCH WIDTH/LENGTH icon to invert the icon. After that, input the data using the numeric icons or the up/down arrow mark icons.

Deflection width, feed amount and creation direction

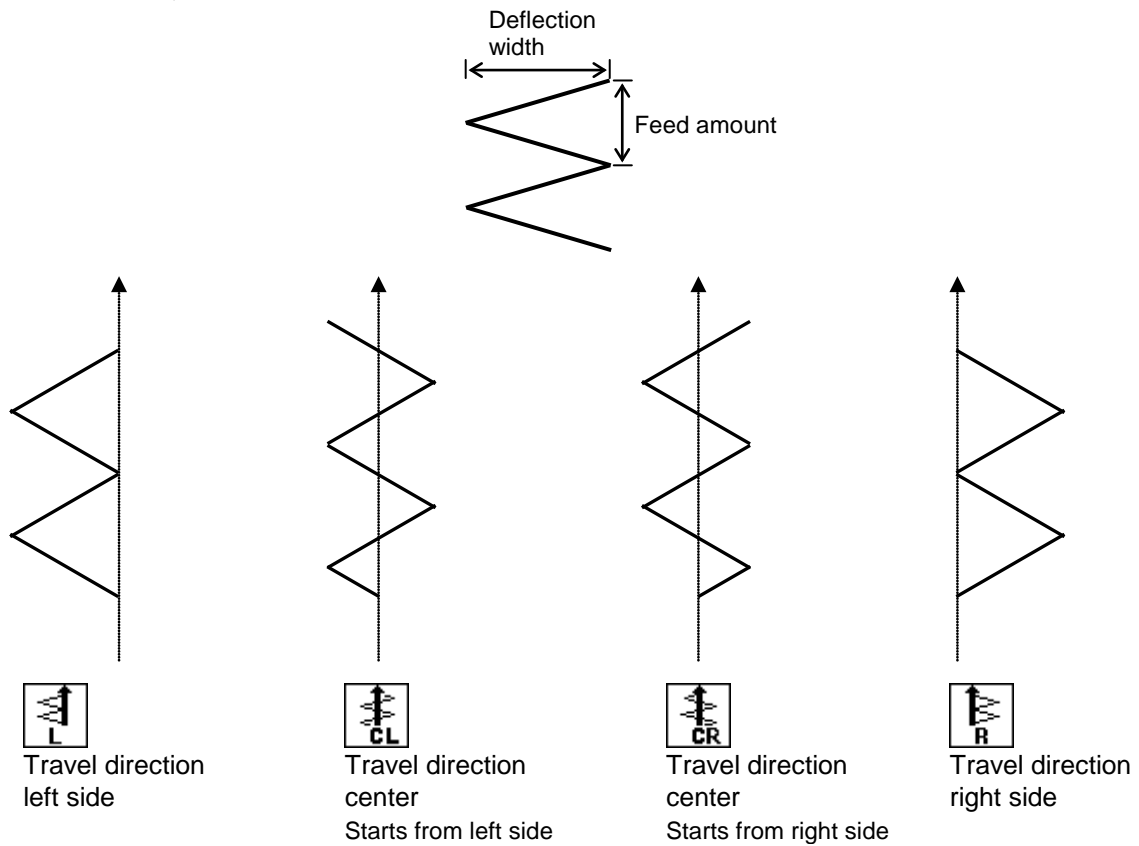



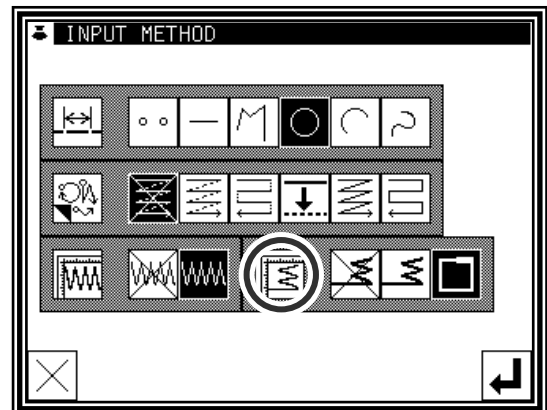

(3) Setting the back tacking details

- ▶ After returning to the Input Method Setting screen, press the back Tacking Details Setting icon .



(4) Setting the overlap back tacking details

- ▶ The details are set on this screen. (The details set here are, , overlap mode,  three overlap stitches.)
- ▶ After inputting the details, press  to set the data.
- ▶ The system will return to the input method setting screen.
- ▶ Press  to determine the set values.
- ▶ The system will return to the input method setting screen.
- ▶ While following the circle data entry procedure, determine points B and C to create the circle data.
- ▶ After creating the circle data, press .

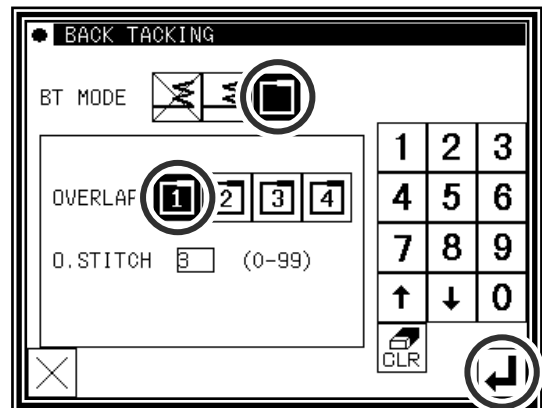

(5) Confirming the data

- ▶ Zigzag stitching (with overlap back tacking)

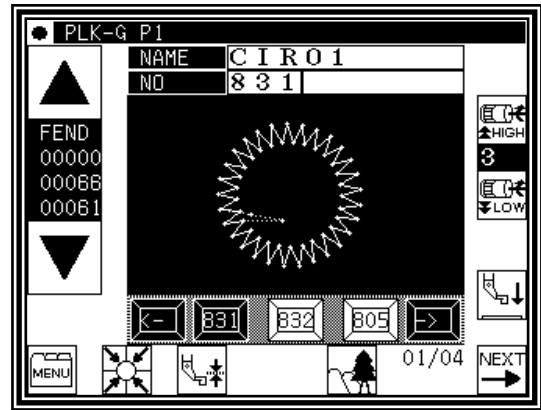

Memo Or press the ZIGZAG icon on the arrow input screen to directly display the ZIGZAG setting screen.

[8] Controlling the Presser Foot

1. Setting for material thickness

The lowest position when the presser foot is lowered can be corrected by following setting. Before sewing operation, please adjust the lowest position of the presser foot.

NOTE If presser foot height is changed by mechanical adjustment, this setting can not be used.

Please use this setting, after return the presser foot height to the factory shipment condition.

(1) Display standard screen

▶ Press material thickness setting 

MEMO For enter to material thickness setting screen, presser foot needs to be up position.

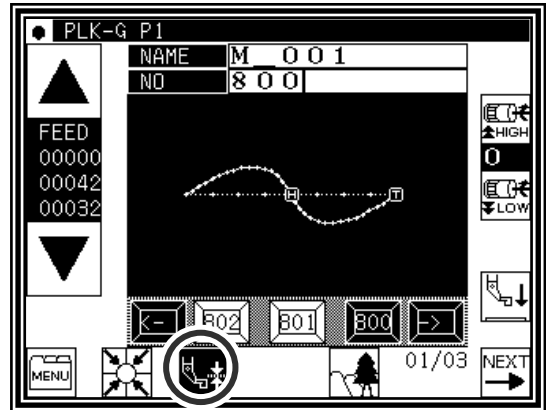

(2) Sets material thickness

▶ Press  then presser foot is lowered. Turn the hand wheel and lowered needle to lowest position. Then up and down arrow icons are activated.

▶ Press up or down arrow icon and adjust material thickness. Setting range is from 0.0 mm to 8.0 mm by 0.2 mm resolution. (Example is set in 4.0 mm in right figure.)

▶ After setting value, press .

▶ Setting is complete, then display is back to standard screen.

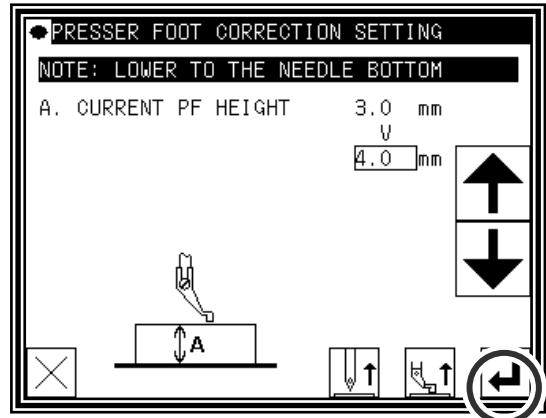
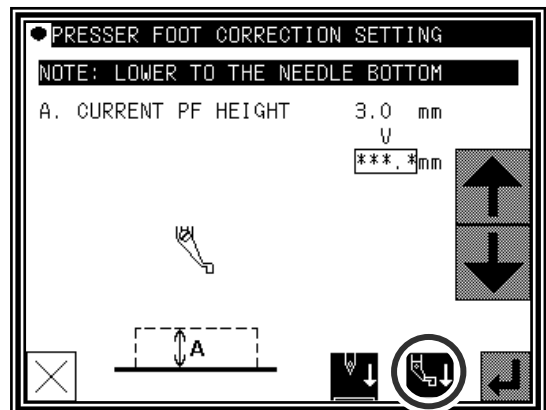

MEMO Setting material thickness is saved (written) in sewing data.

- If material thickness is other than 0 mm, it is saved in the sewing data.
- It can be selected whether to make the preserved value of the presser foot correction effective when the pattern data is read. Please refer to [Program mode> Sewing pattern>HPW]. (Refer to P.[15]-1 for the program mode)

2. Setting for material step level

Presser foot height between the sewing can be changed according to the step of the material thickness. (In change the height of the presser foot according to the situation of the sewing material, it is effective to prevent skip stitch or prevent thread breakage.)

The method in the pattern data input is as follows. Please refer to P.[11]-43 for the pattern data modification.

- (1) On the way of pattern data input, please execute following operation at the position where presser foot height will be changed.

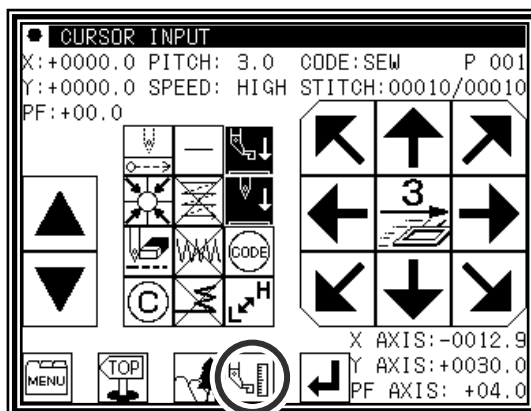

- (2) Setting material step

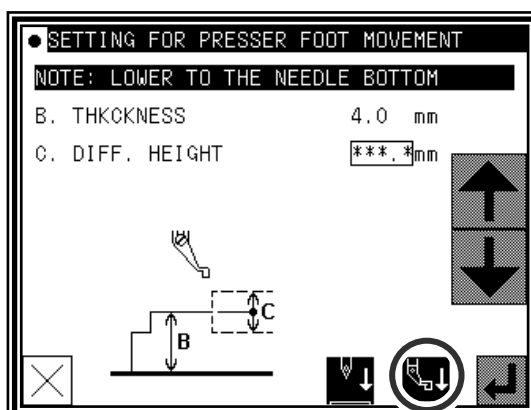
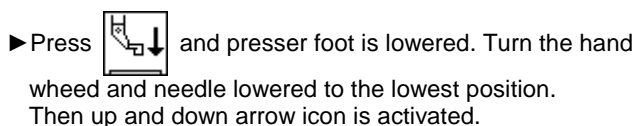

- ▶ Press up and down arrow to change the presser foot height. (example shows presser foot height = 1.6 mm.)

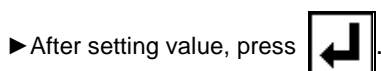

* Please consider interference between the presser foot and the needle bar.

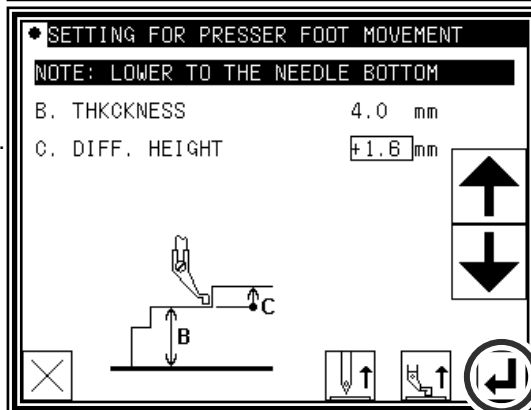





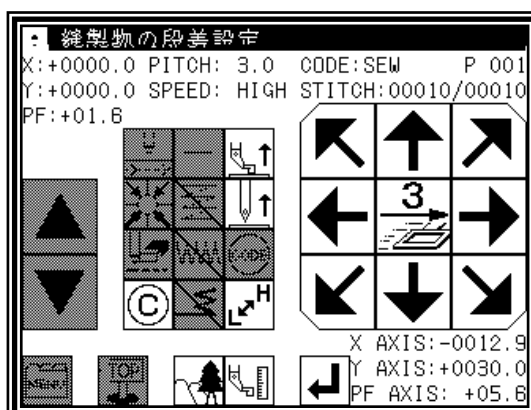













- (3) Next setting (if desired)

- ▶ If there is more position where presser foot height wants to be changed, please repeat above operation (1) to (2).



[9] Table of stitching type combinations

| Basic input | Application input | | | | | |
|---|---|---|---|--|---|---|
| | Multiple  | Reverse multiple  | Offset  | Zigzag  | Start/end back tacking  | Overlap back tacking  |
| Linear  | <input type="checkbox"/> | | | | | |
| | <input type="checkbox"/> | <input type="checkbox"/> | | | | |
| | <input type="checkbox"/> | | <input type="checkbox"/> | | | |
| | <input type="checkbox"/> | | | <input type="checkbox"/> | | |
| | <input type="checkbox"/> | | | | <input type="checkbox"/> | |
| | <input type="checkbox"/> | | | <input type="checkbox"/> | <input type="checkbox"/> | |
| | <input type="checkbox"/> | <input type="checkbox"/> | | <input type="checkbox"/> | | |
| | <input type="checkbox"/> | <input type="checkbox"/> | | | <input type="checkbox"/> | |
| | <input type="checkbox"/> | <input type="checkbox"/> | | <input type="checkbox"/> | <input type="checkbox"/> | |
| | <input type="checkbox"/> | | <input type="checkbox"/> | <input type="checkbox"/> | | |
| | <input type="checkbox"/> | | <input type="checkbox"/> | | <input type="checkbox"/> | |
| | <input type="checkbox"/> | | <input type="checkbox"/> | <input type="checkbox"/> | <input type="checkbox"/> | |
| Arc  | <input type="checkbox"/> | | | | | |
| | <input type="checkbox"/> | <input type="checkbox"/> | | | | |
| | <input type="checkbox"/> | | <input type="checkbox"/> | | | |
| | <input type="checkbox"/> | | | <input type="checkbox"/> | | |
| | <input type="checkbox"/> | | | | <input type="checkbox"/> | |
| | <input type="checkbox"/> | <input type="checkbox"/> | | <input type="checkbox"/> | | |
| | <input type="checkbox"/> | <input type="checkbox"/> | | | <input type="checkbox"/> | |
| | <input type="checkbox"/> | <input type="checkbox"/> | | <input type="checkbox"/> | <input type="checkbox"/> | |
| | <input type="checkbox"/> | | <input type="checkbox"/> | <input type="checkbox"/> | | |
| | <input type="checkbox"/> | | <input type="checkbox"/> | | <input type="checkbox"/> | |
| | <input type="checkbox"/> | | <input type="checkbox"/> | <input type="checkbox"/> | <input type="checkbox"/> | |
| | <input type="checkbox"/> | | <input type="checkbox"/> | <input type="checkbox"/> | <input type="checkbox"/> | |
| Circle  | <input type="checkbox"/> | | | | | |
| | <input type="checkbox"/> | <input type="checkbox"/> | | | | |
| | <input type="checkbox"/> | | <input type="checkbox"/> | | | |
| | <input type="checkbox"/> | | | <input type="checkbox"/> | | |
| | <input type="checkbox"/> | | | | <input type="checkbox"/> | |
| | <input type="checkbox"/> | | | <input type="checkbox"/> | <input type="checkbox"/> | |
| | <input type="checkbox"/> | <input type="checkbox"/> | | <input type="checkbox"/> | | |
| | <input type="checkbox"/> | <input type="checkbox"/> | | | <input type="checkbox"/> | |
| | <input type="checkbox"/> | <input type="checkbox"/> | | <input type="checkbox"/> | <input type="checkbox"/> | |
| | <input type="checkbox"/> | | <input type="checkbox"/> | <input type="checkbox"/> | | |
| | <input type="checkbox"/> | | <input type="checkbox"/> | | <input type="checkbox"/> | |
| | <input type="checkbox"/> | | <input type="checkbox"/> | <input type="checkbox"/> | <input type="checkbox"/> | |
| | <input type="checkbox"/> | | <input type="checkbox"/> | <input type="checkbox"/> | | |
| | <input type="checkbox"/> | | <input type="checkbox"/> | | <input type="checkbox"/> | |
| | <input type="checkbox"/> | | <input type="checkbox"/> | <input type="checkbox"/> | <input type="checkbox"/> | |
| | <input type="checkbox"/> | | <input type="checkbox"/> | <input type="checkbox"/> | <input type="checkbox"/> | |

| Basic input | Application input | | | | | |
|--|--|---|---|---|---|---|
| | Multiple  | Reverse multiple  | Offset  | Zigzag  | Start/end back tacking  | Overlap back tacking  |
| Curve  | <input type="checkbox"/> | | | | | |
| | | <input type="checkbox"/> | | | | |
| | | | <input type="checkbox"/> | | | |
| | | | | <input type="checkbox"/> | | |
| | | | | | <input type="checkbox"/> | |
| | <input type="checkbox"/> | | | <input type="checkbox"/> | | <input type="checkbox"/> |
| | <input type="checkbox"/> | | | | <input type="checkbox"/> | |
| | <input type="checkbox"/> | | | | | <input type="checkbox"/> |
| | <input type="checkbox"/> | | | <input type="checkbox"/> | <input type="checkbox"/> | |
| | <input type="checkbox"/> | <input type="checkbox"/> | | <input type="checkbox"/> | | |
| | | <input type="checkbox"/> | | | <input type="checkbox"/> | |
| | | <input type="checkbox"/> | | | | <input type="checkbox"/> |
| | | <input type="checkbox"/> | | <input type="checkbox"/> | <input type="checkbox"/> | |
| | | | <input type="checkbox"/> | <input type="checkbox"/> | | |
| | | | <input type="checkbox"/> | | <input type="checkbox"/> | |
| | | | <input type="checkbox"/> | <input type="checkbox"/> | <input type="checkbox"/> | <input type="checkbox"/> |
| | | | <input type="checkbox"/> | <input type="checkbox"/> | | <input type="checkbox"/> |
| | Broken line  | <input type="checkbox"/> | | | | |
| | | <input type="checkbox"/> | | | | |
| | | | <input type="checkbox"/> | | | |
| | | | | <input type="checkbox"/> | | |
| | | | | | <input type="checkbox"/> | |
| <input type="checkbox"/> | | | | <input type="checkbox"/> | | <input type="checkbox"/> |
| <input type="checkbox"/> | | | | | <input type="checkbox"/> | |
| <input type="checkbox"/> | | | | | | <input type="checkbox"/> |
| <input type="checkbox"/> | | | | <input type="checkbox"/> | <input type="checkbox"/> | |
| <input type="checkbox"/> | | <input type="checkbox"/> | | <input type="checkbox"/> | | |
| | | <input type="checkbox"/> | | | <input type="checkbox"/> | |
| | | <input type="checkbox"/> | | | | <input type="checkbox"/> |
| | | <input type="checkbox"/> | | <input type="checkbox"/> | <input type="checkbox"/> | |
| | | | <input type="checkbox"/> | <input type="checkbox"/> | | |
| | | | <input type="checkbox"/> | | <input type="checkbox"/> | |
| | | | <input type="checkbox"/> | <input type="checkbox"/> | <input type="checkbox"/> | <input type="checkbox"/> |
| | | | <input type="checkbox"/> | <input type="checkbox"/> | | <input type="checkbox"/> |
| Point  | | (Combination inputs with application inputs are not possible.) | | | | |

Combined pattern

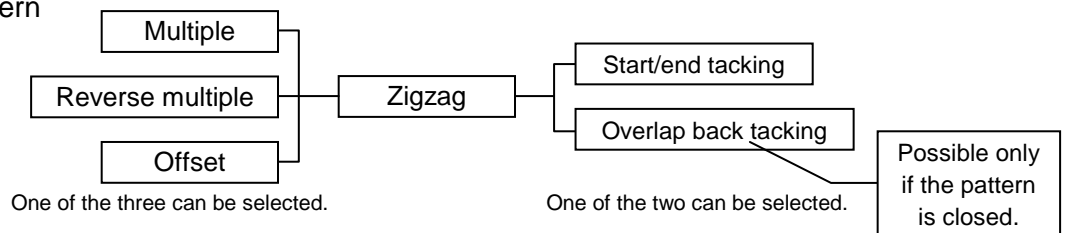

[10] Call-up function

In the sewing data input mode, you can call up the sewing data from the internal memory, and can combine the called-up data with the currently-created data to create a new sewing data. You can determine whether the first and final feed data should be deleted.

[Example of call-up function]

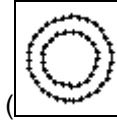

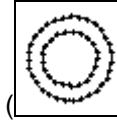
To create the following sewing data, preliminarily create the double circle data (), and then use the feed data and call-up functions.

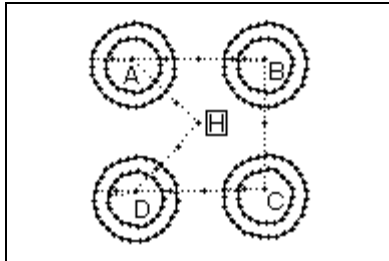

Operation details

(1) Creation of data on feed data from home position H to point A

(2) Display of call-up screen

▶ Press the data entry mode  .

▶ Press  in the menu.

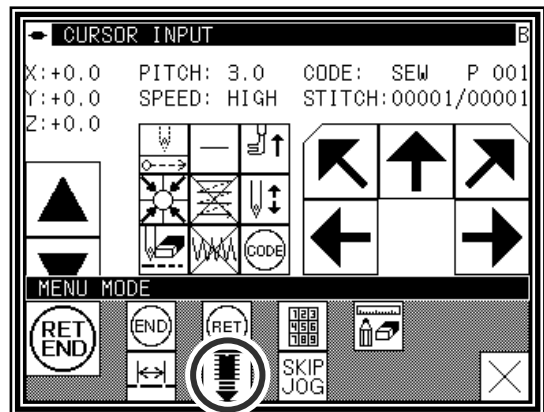



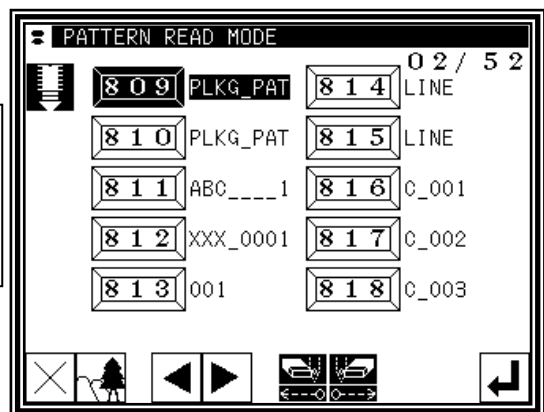

(3) Selection of call-up data

▶ Select data to be called up, and then press  .

Caution The work holder will automatically move in accordance with the called-up data. If the needle is lowered, be careful not to get injured.



























Memo After calling up "feed" data, you can modify the original "feed" data as follows

-  : The feed data at the sewing start point can be deleted.
-  : The feed data at the sewing end point can be deleted.
-  : The feed data at the sewing start point can be left undeleted.
-  : The feed data at the sewing end point can be left undeleted.



(4) For B, C, and D, call up the data in the same way, and complete the data.

[11] Modification mode

1. Main modification mode functions

| | Function | icon | Details | Details setting |
|---|---|---|--|--|
|  Stitch | Modifying the stitching start position ([11]-5) |  | The stitching start position moves. | - |
| | Deleting a stitch ([11]-7) |  | Deletes the designated stitch. |   |
| | Adding a stitch ([11]-11) |  | Data for one stitch is added at designated position |   |
| | Modifying the stitch position ([11]-15) |  | The position of the stitch is modified |   |
| | Moving a block ([11]-19) |  | Data in a designated range is moved. |   |
| | Modifying a block ([11]-23) |  | The area between two points to be modified is modified with linear, broken line, arc, curve, zigzag or feed data. | - |
| | Modifying stitch length ([11]-39) |  | The stitch length in the designated range is modified. |   |
| | Modifying material step ([11]-43) |  | The presser foot height at the specified position is modified. | - |
| Modifying the stitching speed ([11]-46) |  | The stitching speed is modified from the designated stitch. |   | |
| Modifying code data ([11]-50) |  | Code data is added to or deleted from designated stitch position. |  Add  Delete | |

2. Entering the modification mode

- Press  and  on the Standard screen to enter the modification mode.

- press  and  in the input mode to enter the modification mode.

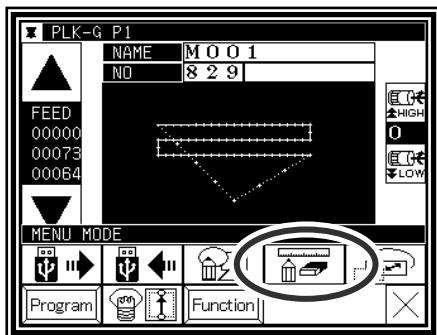

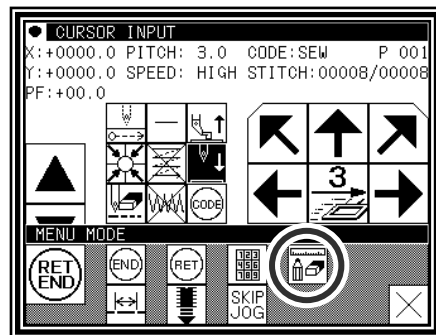

Method that uses standard screen



Method that uses data input mode

3. Quitting the modification mode

- ▶ After making modifications, press  to quit the modification mode.

(When  is pressed, the modifications executed last will be undone.)

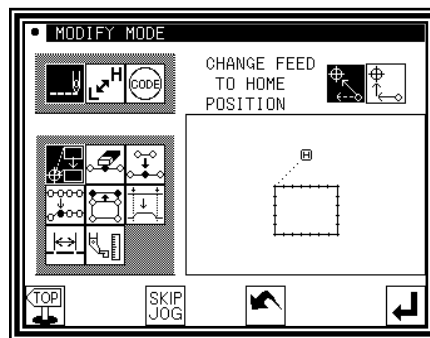

4. Changing the feed data to home position

- ▶ An example for adding the A' point by adding one stitch to the original stitching data, as shown on the left, is explained in this section.

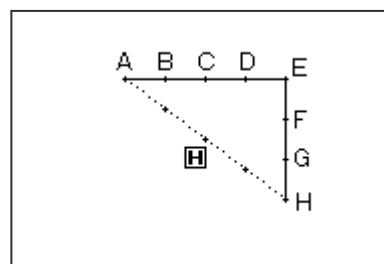

- ▶ Add the A' point as shown on the right.

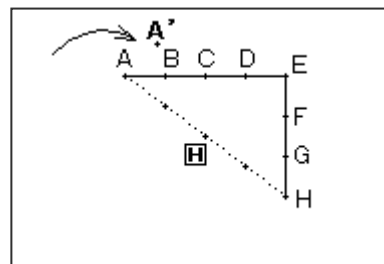

- ▶ The B point to H point positions will change when the A' point is added. Thus, the feed data from the H point to the home position will also change. The method for changing this feed data can be selected with the following icons.

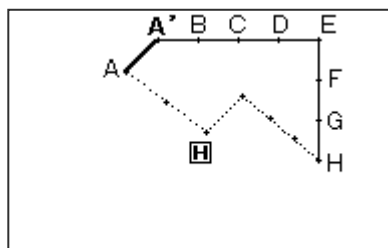
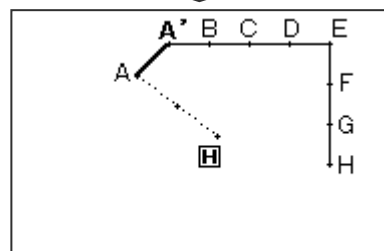

[Add return]

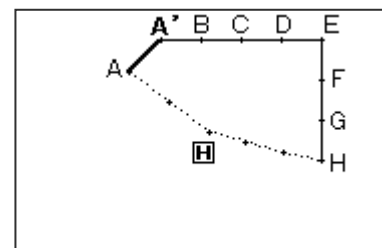

[Change return]

Memo Before modification, check the data. If the data on feed data from the sewing end point to the home position includes code data, the feed data following the code data will be modified.

5. Confirming on the image screen

If the image display icon  is pressed in the input mode, modification mode or conversion mode, the Image screen will open. This Image screen can be used effectively when modifying (converting) data in the modification (conversion) mode, and the data can be modified (converted) easily.

An example of the Image screen in the modification mode is shown below. The Image screen can be confirmed after the data modification (conversion) mode is entered, regardless of before and after modifications made.

- When stitching start position is modified



: Closes the Image screen, and opens the previous screen. (Common for all Image screens.)



: Indicates the home position. (Common for all Image screens.)



: Indicates the original stitching start position.



: Indicates the modified stitching start position. (Current position moved to with the arrow icons.)

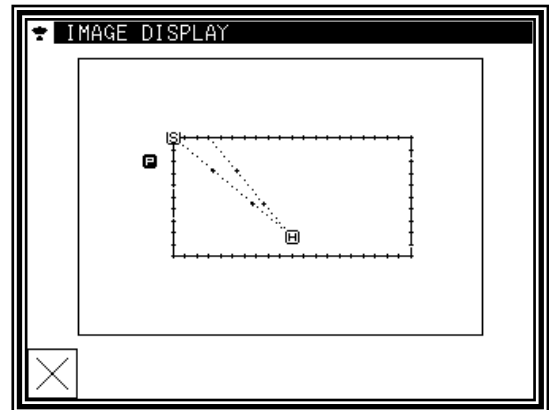

<Only the image section is shown in the following explanations.>

- Deleting stitches



: Indicates the home position. (Common for all Image screens.)



: Indicates the stitch deletion start position.



: Indicates the stitch deletion end position.

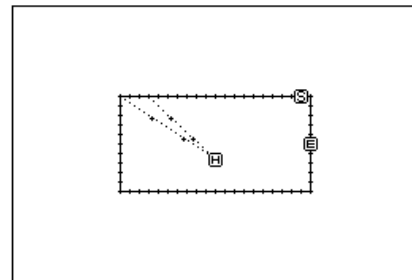

- Modifying the stitch position and adding stitches



: Indicates the home position. (Common for all Image screens.)



: Indicates the original stitch position/stitch addition reference position.



: Indicates the modified stitch position/added stitch position. (Current position moved to with the arrow icons.)

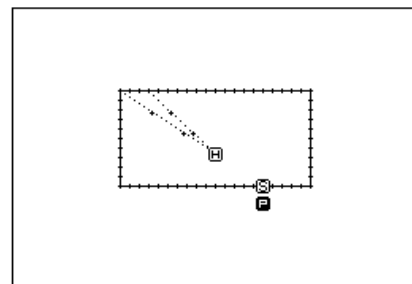

- Moving a block



: Indicates the home position. (Common for all Image screens.)



: Indicates the block movement start position.



: Indicates the block movement end position.



: Indicates the position after block movement modification.

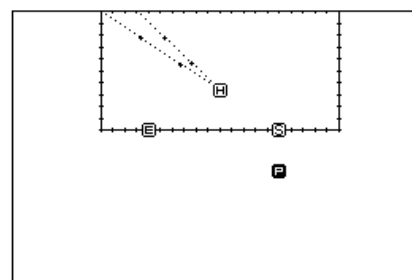

6.Modifying the stitching start position

[Example] The stitching start position A point in the stitching data will be modified to the B point as shown below.

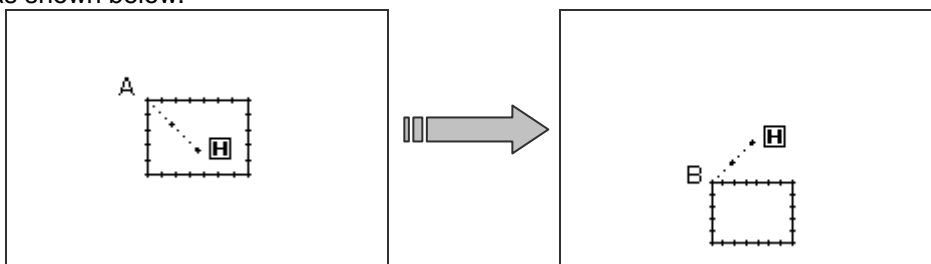

Operation details

(1)Selecting the stitching start position movement

▶ Enter the modification mode. (Refer to the methods for entering the modification mode. Page[11]-1)

▶ Press Stitch Data Change  and Stitching Start

Position Move .

▶ Press  to set the data.

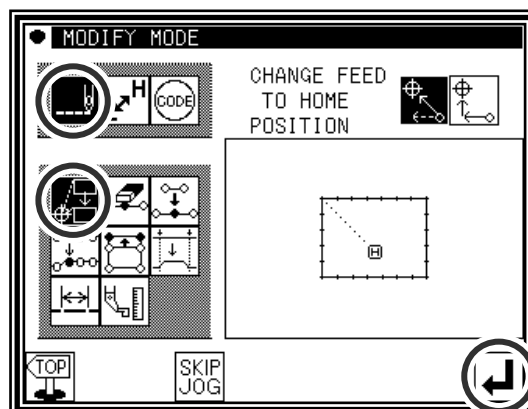

Caution The work holder will automatically move to the current stitching start position.
(*1)Take care when the needle is lowered, etc.

(2)Moving to the modification position and setting the data

▶ Press the arrow icons to move the position to the B point.

▶ Press .



(The sewing start position will be modified.)

Caution When the modifications are undone, the work holder will automatically return to the home position. Take care when the needle is lowered, etc.

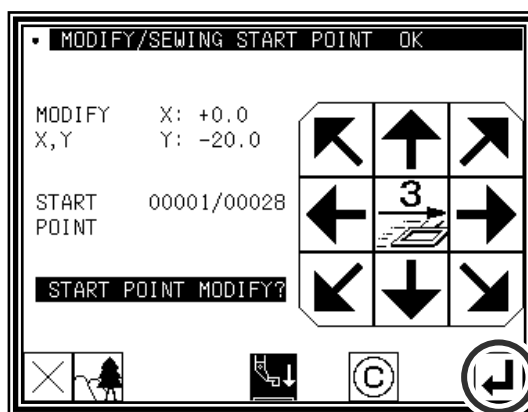
▶ If  is pressed here, the screen will change to the previous screen.



(3)Confirming the modified data

▶ Quit the modification mode. Press  to change to the Saving mode screen. Press  to return to the Standard screen after saving the data.

(When  is pressed, the modifications executed last will be undone.)

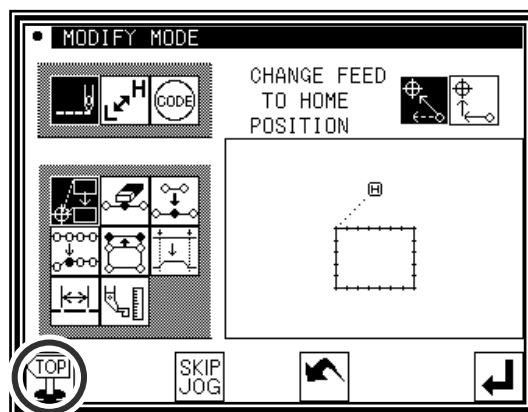

(4)Confirming with the Standard screen

► The stitching start position has been modified.

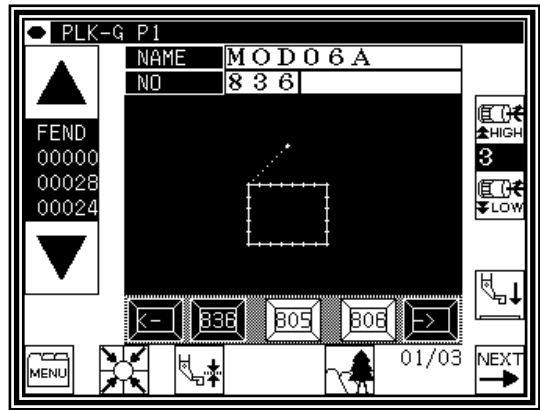

(*1)

Memo

Please note that there is a characteristic explained as follows about " Modifying the stitching start position "

The data of the figure below is the straight line data which puts the start/end back tacking of V mode. (A fat part is back tacking).

In this case, is sewn in order of A→B→C→D.

Therefore, the actual stitch starting position is "A point." (Starting location of the data origination (input) is "B point."



Please specify whether to correct the B point because " Starting location (B) at the data input " after work holder automatically moves to "Actual stitch starting position (A)" when enters to " Modifying the stitching start position "

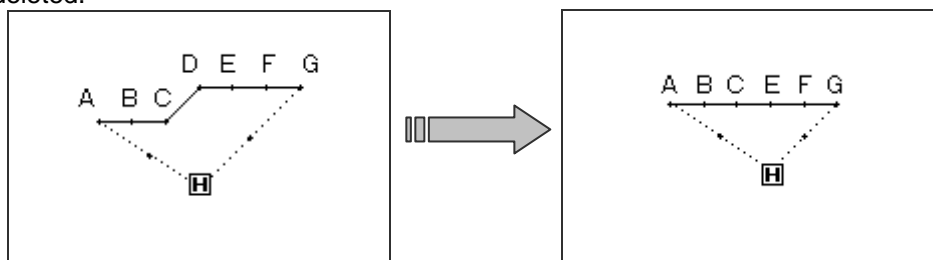

7. Deleting a stitch (Deleting the designated No. of stitches)

[Example] The stitching pattern between the C point and D point in the following type of stitching data will be deleted.





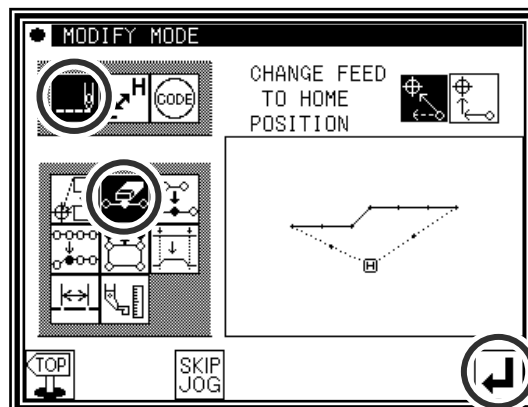

Operation details

(1) Selecting deletion of stitches

- ▶ Enter the modification mode. (Refer to the methods for entering the modification mode. Page[11]-1)
- ▶ Press Stitch Data Change  and
Stitch Delete .
- ▶ Press  to open the next screen.



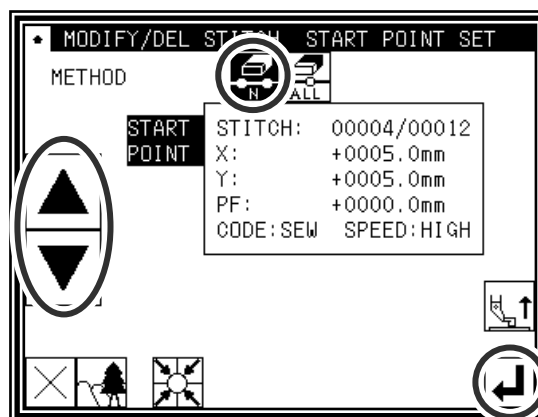

(2) Determining the deletion method and the deletion range (start point)

- ▶ Press No. of Stitch Designation .
- ▶ Using Jog , , determine the start point position (C point).
- ▶ Press  when the position has been set.



(3) Determining the deletion range (end point)

- ▶ Using Jog , , determine the end point position (D point).
- ▶ Press  when the position has been set.

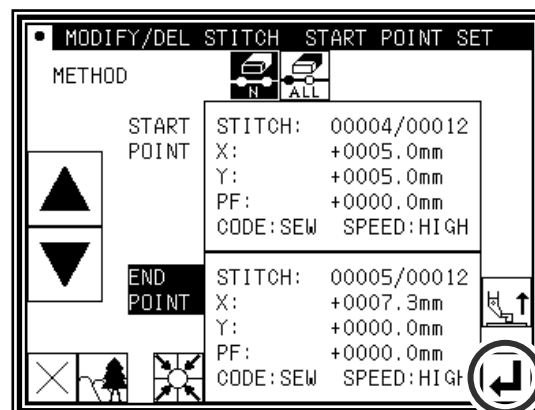



Caution When the end point is determined, the work holder will automatically return to the start point. Take care when the needle is lowered, etc.

(4) Confirming execution

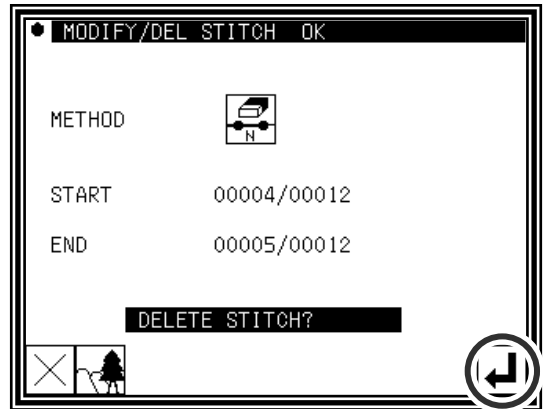
- ▶ Press  .
(The stitch will be deleted.)



(5) Confirming after stitch deletion

- ▶ Quit the modification mode. Press  to change to the Saving mode screen. Press  to return to the Standard screen after saving the data.
(When  is pressed, the modifications executed last will be undone.)

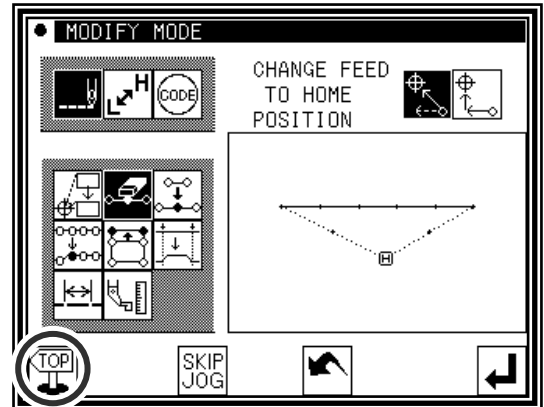

(6) Confirming with the Standard screen

- ▶ The stitch has been deleted.

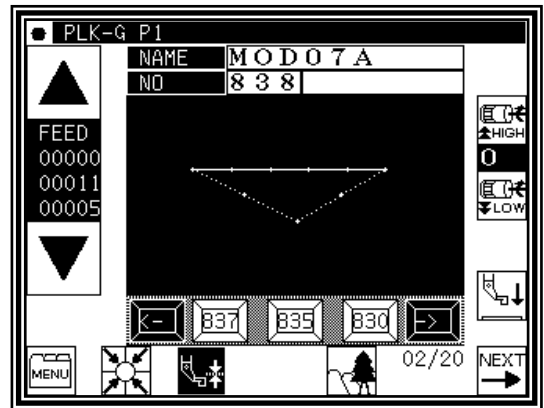

8. Deleting a stitch

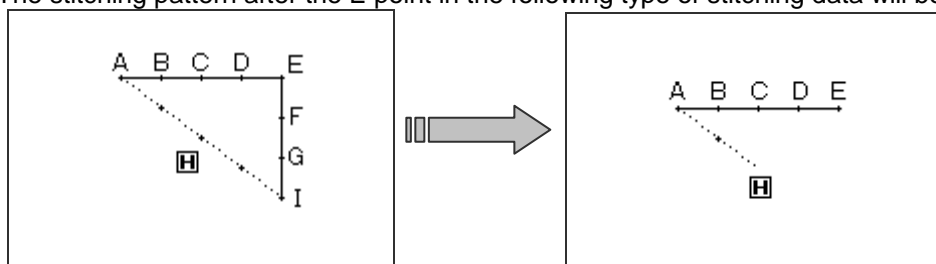

(Deleting all stitches after the designated position)

[Example] The stitching pattern after the E point in the following type of stitching data will be deleted.





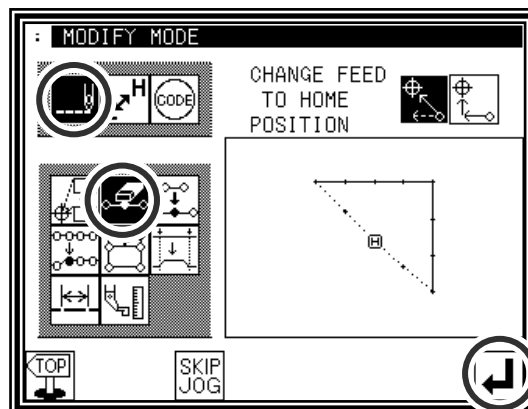

Operation details

(1) Selecting deletion of stitches

- ▶ Enter the modification mode.
- ▶ Press Stitch Data Change  and Stitch Delete .
- ▶ Press  to open the next screen.



(2) Determining the deletion method and the deletion range (start point)

- ▶ Press All After Designated Stitch . (All the data below the specified position will be deleted.)
- ▶ Using Jog , , determine the start point position (E point).
- ▶ Press  when the position has been set.

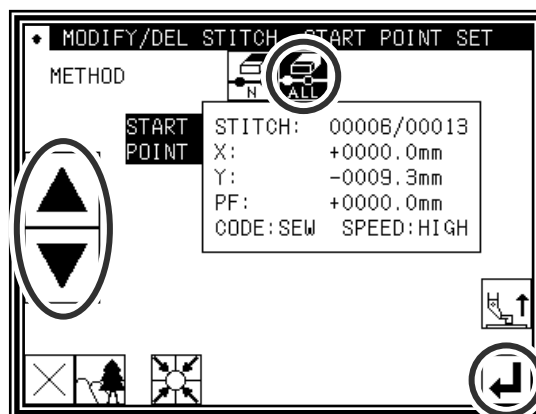

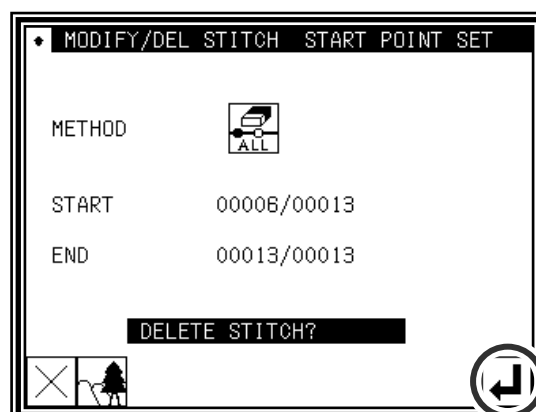

(3) Confirming execution

- ▶ press .
- (All the data below the specified position will be deleted.)



(4) Confirming after stitch deletion

- ▶ Quit the modification mode. Press  to change to the Saving mode screen. Press  to return to the Standard screen after saving the data. (When  is pressed, the modifications executed last will be undone.)

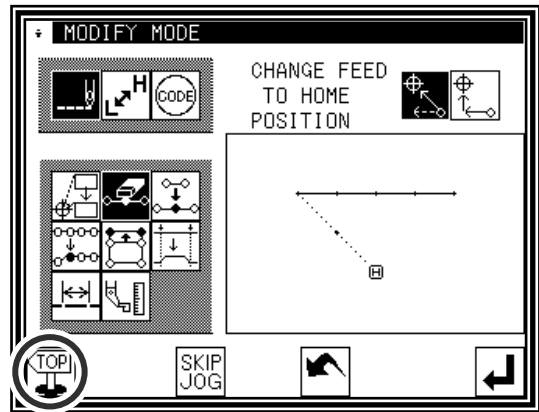

(5) Confirming with the Standard screen

- ▶ The stitches have been deleted.

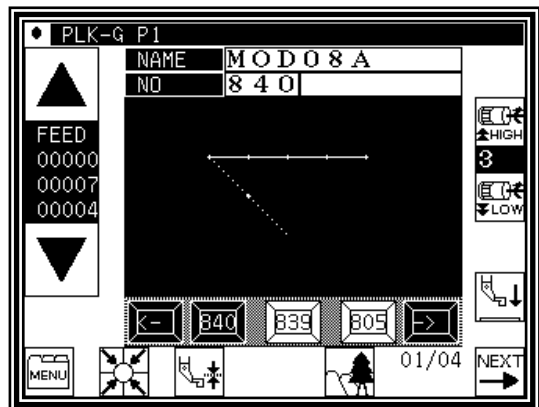

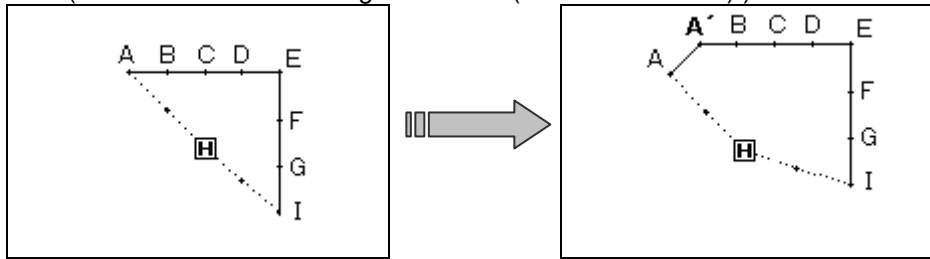

9. Adding a stitch (Adding one stitch)

[Example] The required stitch length A' will be added to the A point of the following type of stitching
(The maximum stitch length is 20mm (between A and A').)





Operation details

(1) Selecting stitch addition

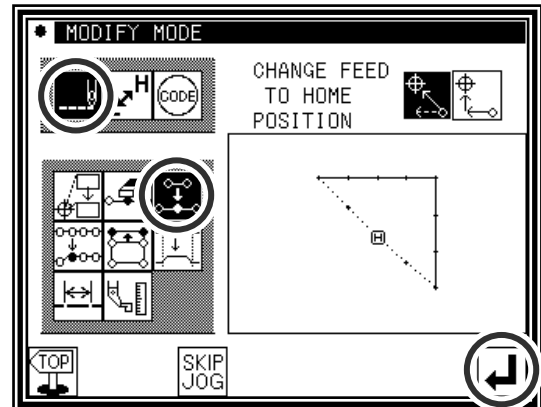
- ▶ Enter the modification mode.
- ▶ Press **Stitch Data Change**  and **Stitch Add** .
- ▶ Press  to open the next screen.



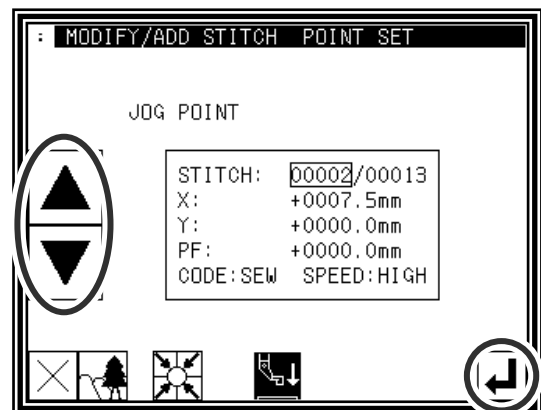

(2) Determining the addition position

- ▶ Using Jog , , determine the position to be added. Move to the addition position (point A).
- ▶ Press  when the position has been set.



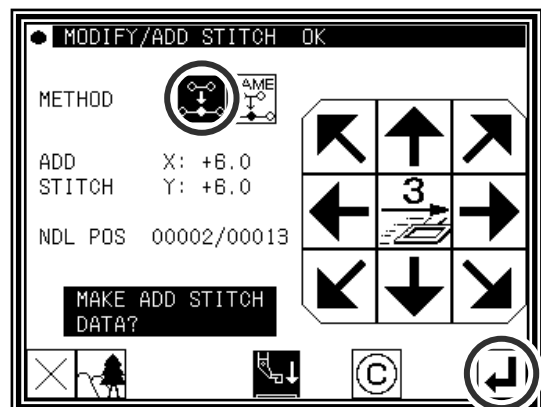

(3) Setting the addition method

- ▶ Press **One Stitch Addition** , and then use the arrow icons to move and input the stitch position to be added. (A' point)
- ▶ Press .
(One stitch will be added.)



(4) Confirming after stitch addition

- ▶ Quit the modification mode. Press  to change to the Saving mode screen. Press  to return to the Standard screen after saving the data. (When  is pressed, the modifications executed last will be undone.)

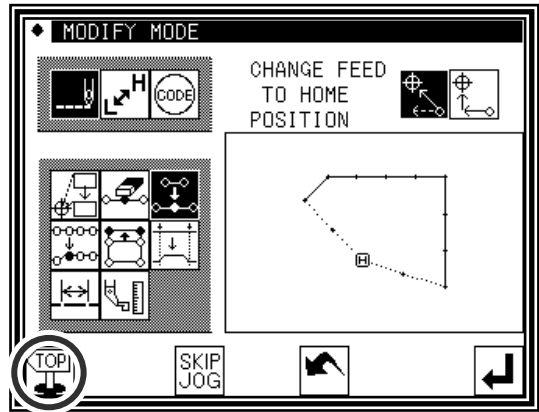

(5) Confirming with the Standard screen

- ▶ One stitch has been added.

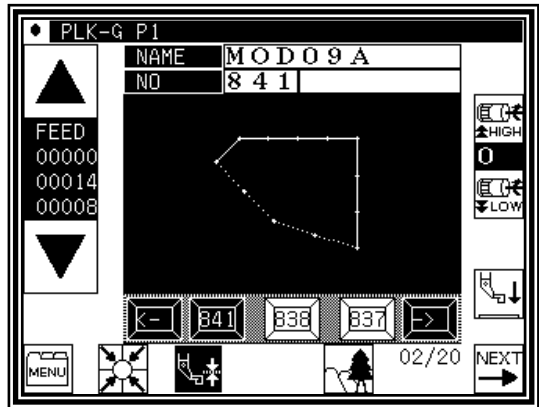

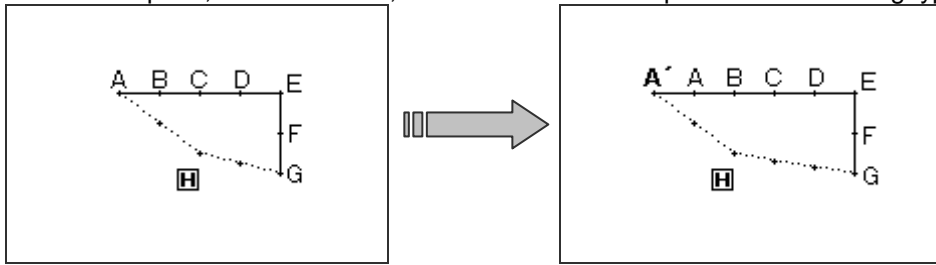

10. Adding a stitch (Adding the same stitch)

[Example] The stitch A' point, the same as A, will be added to the A point of the following type of stitching data.





Operation details

(1) Selecting stitch addition

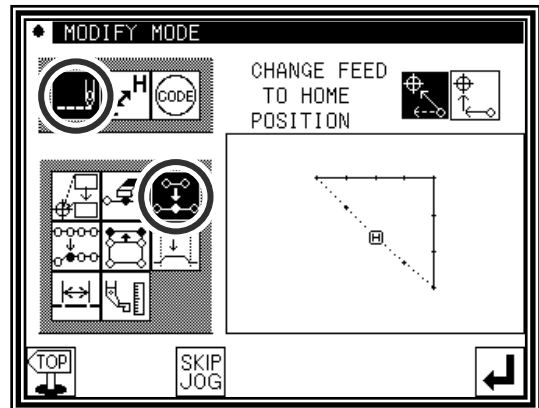
- ▶ Enter the modification mode.
- ▶ Press Stitch Data Change  and Stitch Add .
- ▶ Press  to open the next screen.



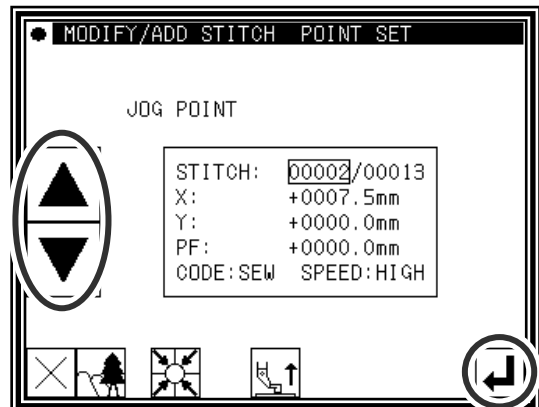

(2) Determining the addition position

- ▶ Using Jog , , determine the position to be added. Move to the addition position (point A).
- ▶ Press  when the position has been set.



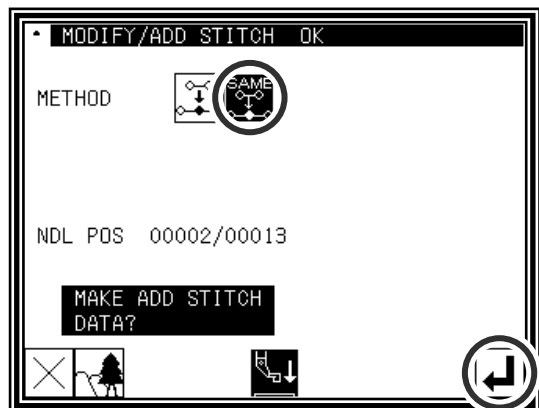

(3) Setting the addition method

- ▶ Press Same Stitch Addition ,
- and then press .
- (The same stitch will be added.)



(4) Confirming after stitch addition

- ▶ Quit the modification mode. Press  to change to the Saving mode screen. Press  to return to the Standard screen after saving the data. (When  is pressed, the modifications executed last will be undone.)

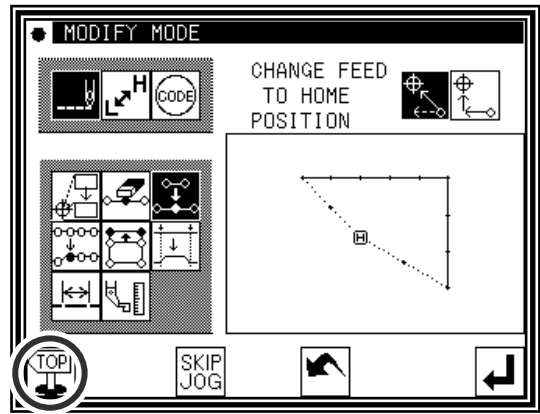

(5) Confirming with the Standard screen

- ▶ The same stitch has been added.

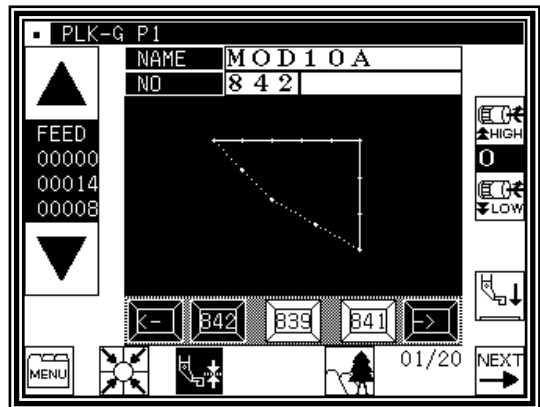

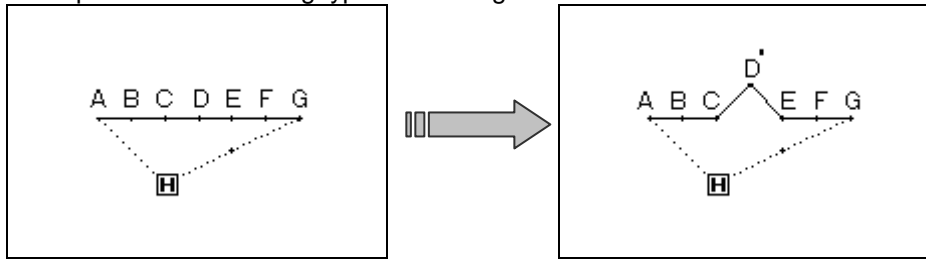

11. Modifying the stitch position (Position of subsequent data fixed)

[Example] The D point in the following type of stitching data will be moved.





Operation details

(1) Selecting stitch position modification

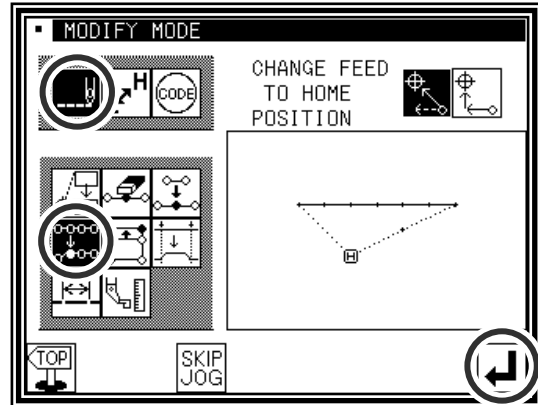
- ▶ Enter the modification mode.
- ▶ Press **Stitch Data Change**  and **Stitch Position Modify** .
- ▶ Press  to open the next screen.



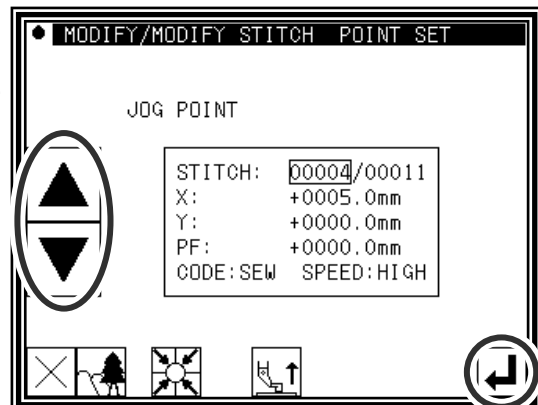

(2) Determining the modification position

- ▶ Using Jog  ,  , determine the position to be modified.(D point)
- ▶ Press  when the position has been set.





(3) Setting the modification method and modification amount

- ▶ To set the method, press  (pattern data after modification stitch fixed), and move to the modification position (point D') using the arrow mark icons.
- ▶ Press .
(The stitch position will be modified.)

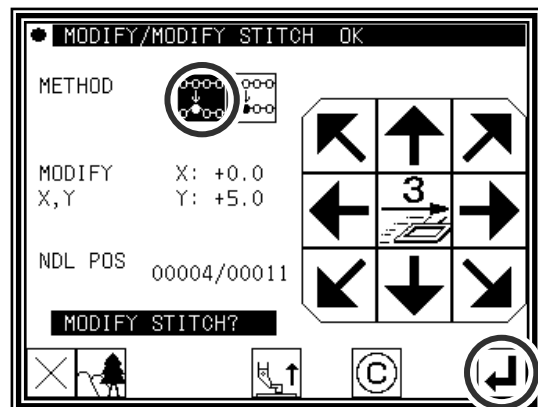
Memo Move the stitch length so that it is within the range of 20mm at the maximum.



(4) Confirming after modification

- ▶ Quit the modification mode. Press  to change to the Saving mode screen. Press  to return to the Standard screen after saving the data. (When  is pressed, the modifications executed last will be undone.)

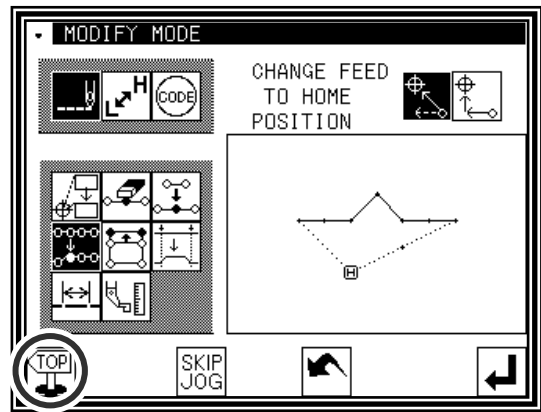

(5) Confirming with the Standard screen

- ▶ The stitch position has been modified.

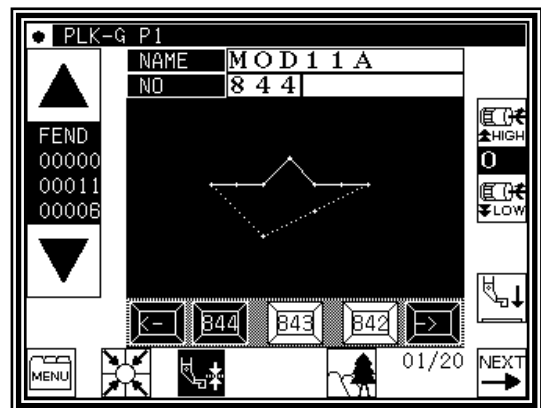

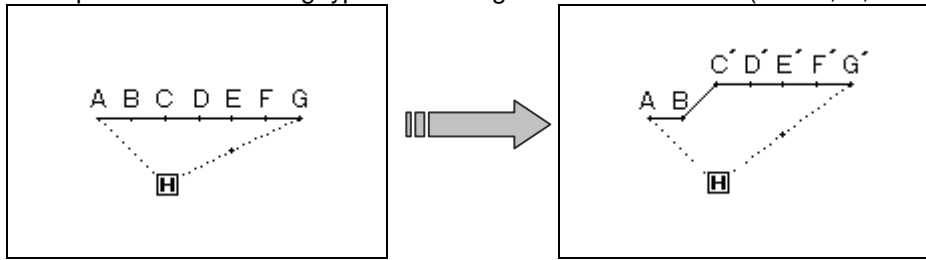

12.Modifying the stitch position (Subsequent data position moved)

[Example] The C point in the following type of stitching data will be moved. (The D, E, F and G points will move)





Operation details

(1)Selecting stitch position modification

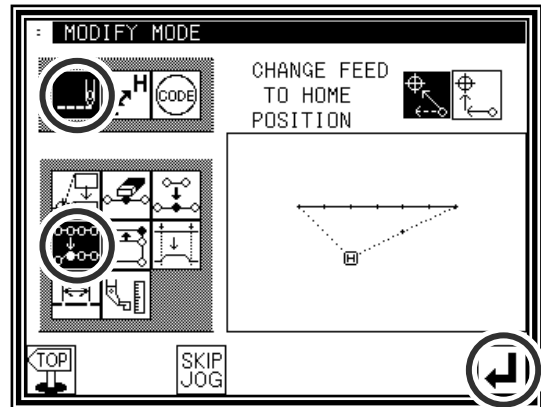
- ▶ Enter the modification mode.
- ▶ Press Stitch Data Change  and
Stitch Position Modify .
- ▶ Press  to open the next screen.



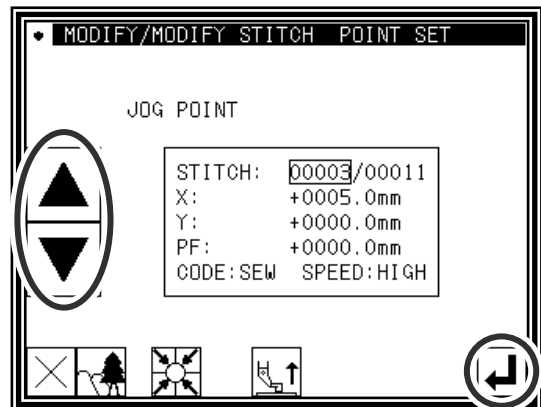

(2)Determining the modification position

- ▶ Using Jog , , determine the position to be modified.(C point)
- ▶ Press  when the position has been set.





(3)Setting the modification method and modification amount

- ▶ To set the method, press .
(pattern data after modification stitch moved), and
Move to the modification position (point C') using the
arrow mark icons.
- ▶ Press .
- (The stitch positions will be modified.)

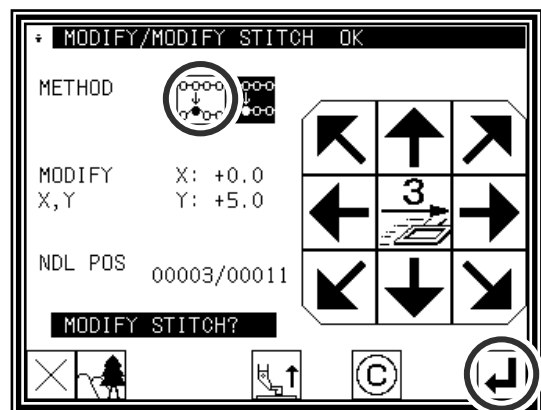
Memo Move the stitch length so that it is within the range of 20mm at the maximum.



(4) Confirming after modification

- ▶ Quit the modification mode. Press  to change to the Saving mode screen. Press  to return to the Standard screen after saving the data. (When  is pressed, the modifications executed last will be undone.)

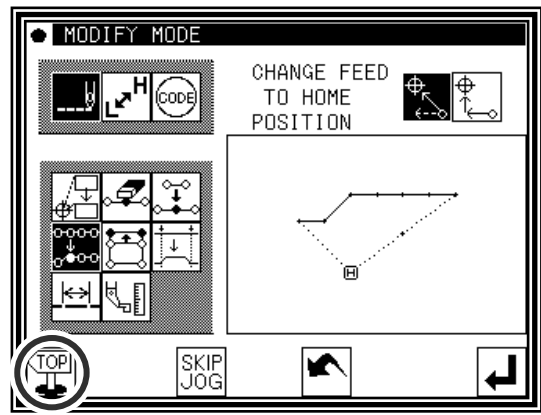

(5) The stitch position has been modified.

- ▶ The stitch positions have been modified.

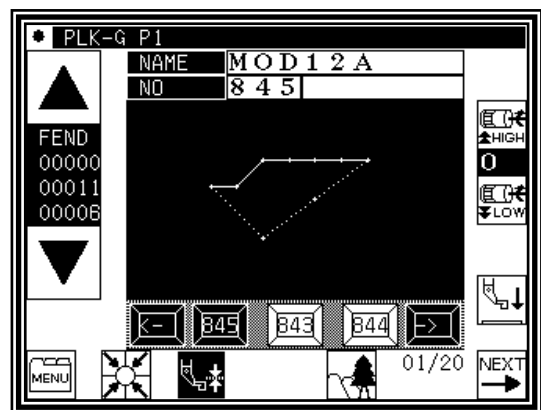

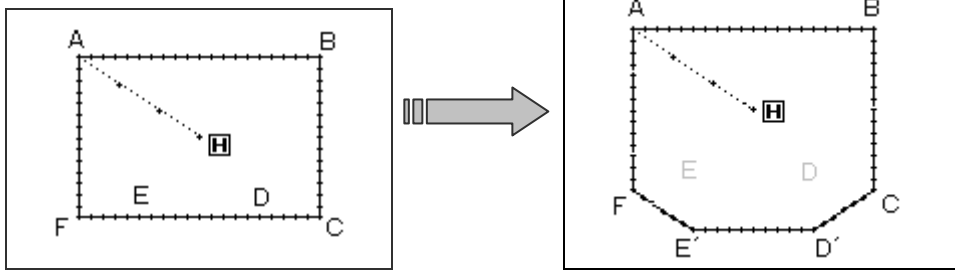

13.Moving a block (Changing the prior/subsequent data)

[Example] The section between the D point and E point of the following type of stitching data will be moved to the D' point to E' point. At this time, the data prior to and after the D' point to E' point will be changed.





Operation details

(1)Selecting block movement

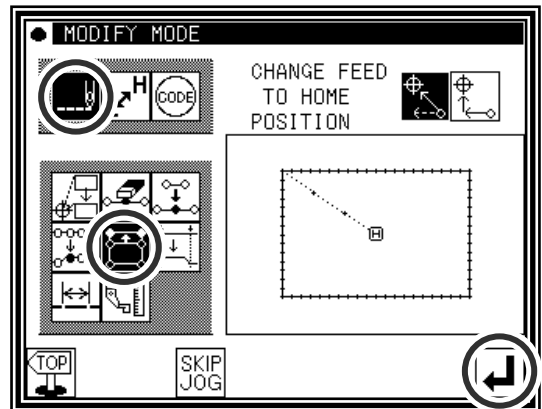
- ▶ Enter the modification mode.
- ▶ Press Stitch Data Change  and Block Move .
- ▶ Press  to open the next screen.



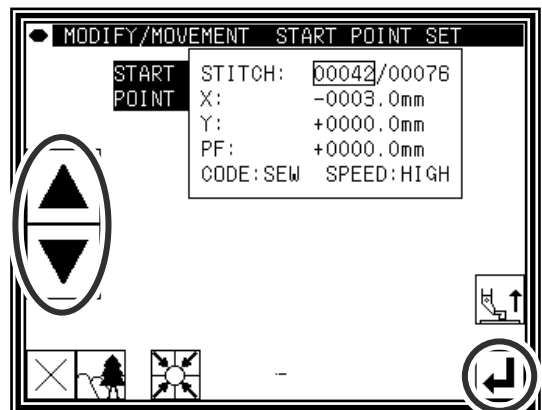

(2)Determining the block modification range (start point)

- ▶ Using Jog  ,  , determine the start point position.(D point)
- ▶ Press .



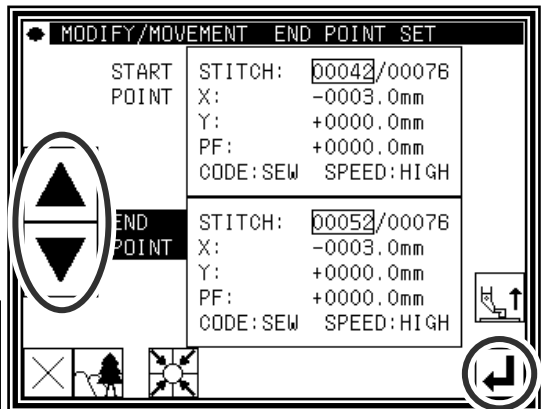

(3)Determining the block modification range (end point)

- ▶ Using Jog  ,  , determine the end point position.
- ▶ Press .



Caution When the end point is determined, the presser will automatically return to the start point. Take care when the needle is lowered, etc.

(4) Setting the movement method and stitch length

- ▶ Set the movement method. Press Prior/Subsequent Data Change .
- ▶ Set the stitch length. (Set to 3.0mm for this example.)
- ▶ Press .

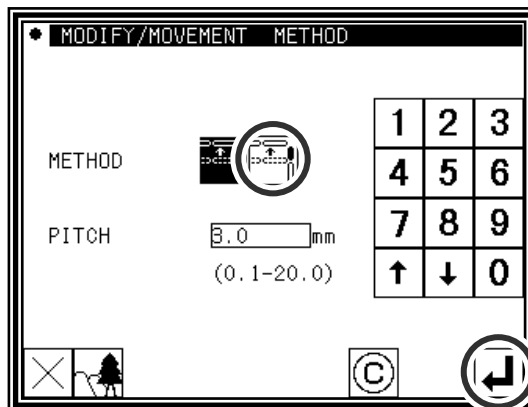



(5) Determining the movement amount

- ▶ Using the arrow icons, determine the movement amount. (Move to the position (point D').)
 - ▶ Press .
- (The block position will be modified.)

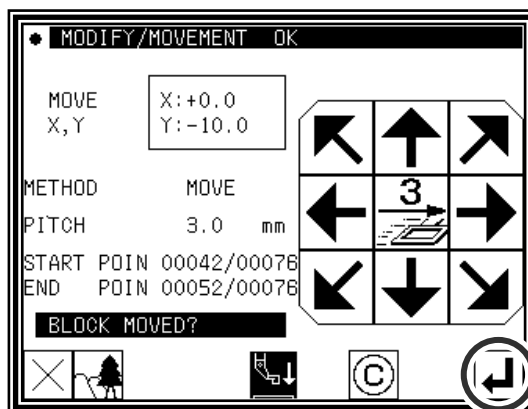
Caution The work holder will move. (The work holder will return to the start point of the section being modified; in this case the start point (A point) of the broken line input.) Take care when the needle is lowered, etc.



(6) Confirming after modification

- ▶ Quit the modification mode. Press  to change to the Saving mode screen. Press  to return to the Standard screen after saving the data. (When  is pressed, the modifications executed last will be undone.)

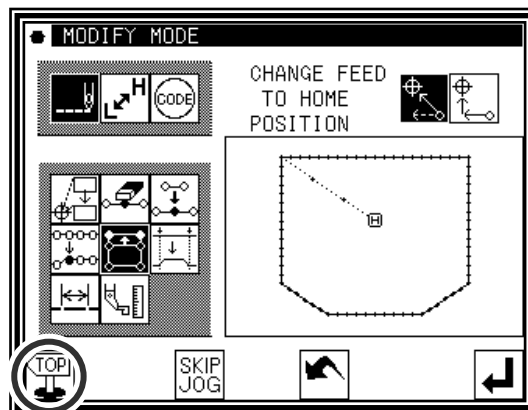

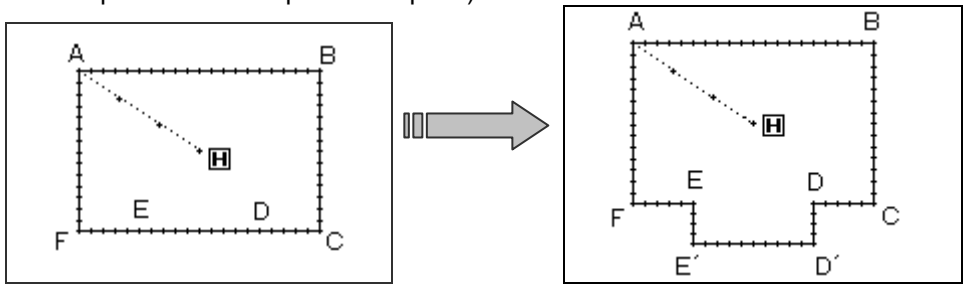

14. Moving a block (Adding new data to the prior/subsequent data)

[Example] The section between the D point and E point of the following type of stitching data will be moved to the D' point to E' point. At this time, new data will be added prior to and after the D' point to E' point. (the D point to D' point and the E point to E' point)





Operation details

(1) Selecting block movement

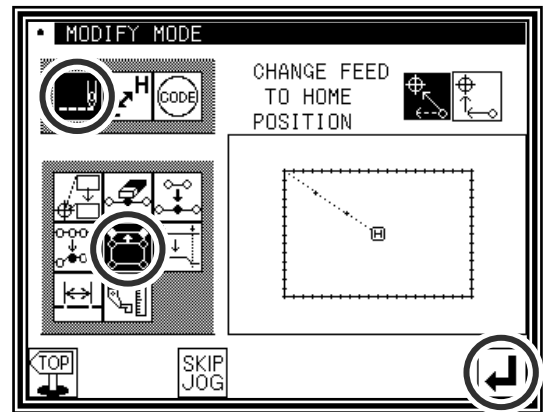
- ▶ Enter the modification mode.
- ▶ Press Stitch Data Change  and Block Move .
- ▶ Press  to open the next screen.



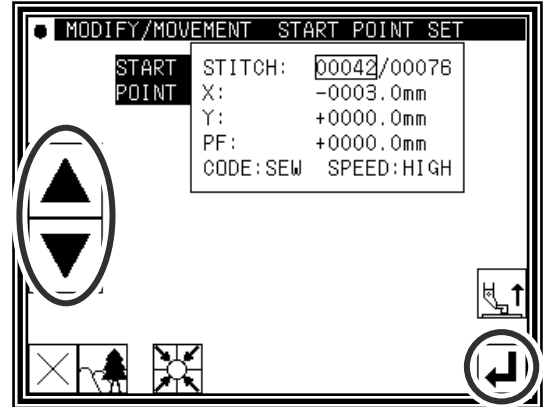

(2) Determining the block modification range (start point)

- ▶ Using Jog  ,  , determine the start point position.(D point)
- ▶ Press .



(3) Determining the block modification range (end point)

- ▶ Using Jog  ,  , determine the end point position.(E point)
- ▶ Press .

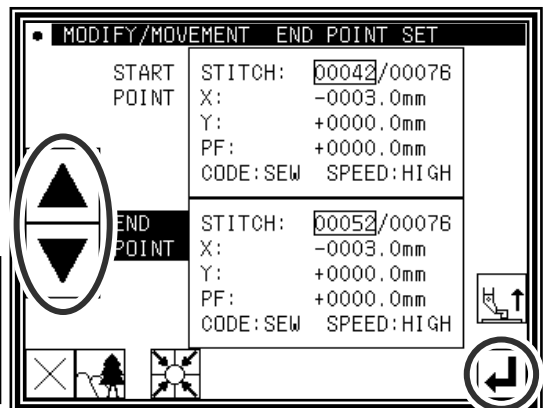

Caution When the end point is determined, the presser will automatically return to the start point. Take care when the needle is lowered, etc.

(4) Setting the movement method and stitch length

- ▶ Set the movement method.
Press Add New Stitch To Prior/Subsequent Data



- ▶ Set the stitch length.
(Set to 3.0mm for this example.)

- ▶ Press .

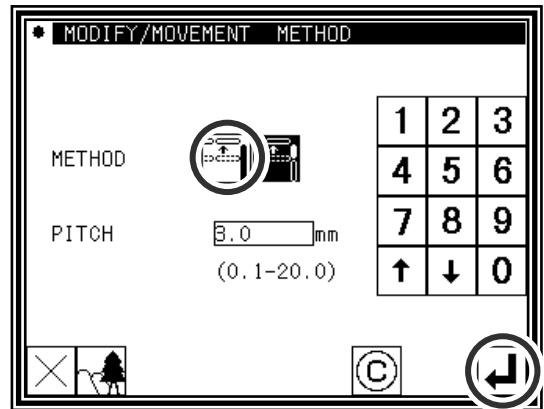

(5) Determining the movement amount



- ▶ Using the arrow icons, determine the movement amount. (Move to the position (point D').)

- ▶ Press .

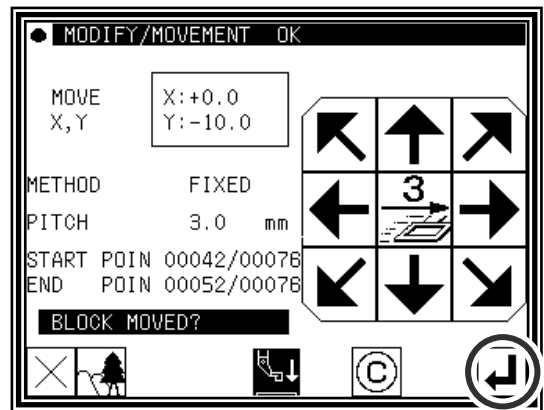
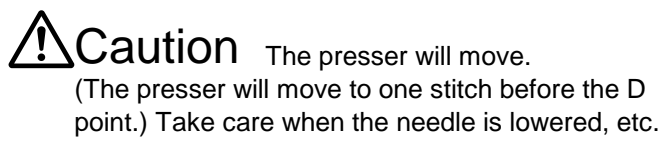
(The block position will be modified.)



(6) Confirming after modification

- ▶ Quit the modification mode. Press  to change to the Saving mode screen. Press  to return to the Standard screen after saving the data.
(When  is pressed, the modifications executed last will be undone.)

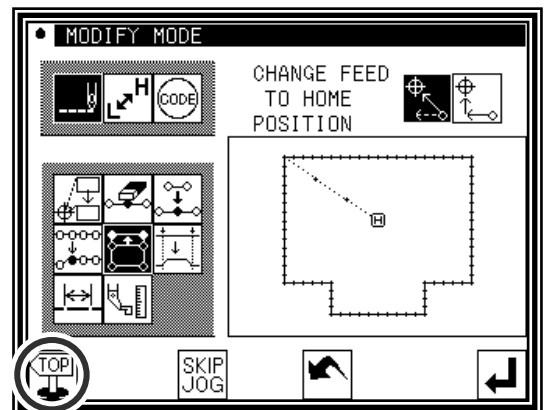

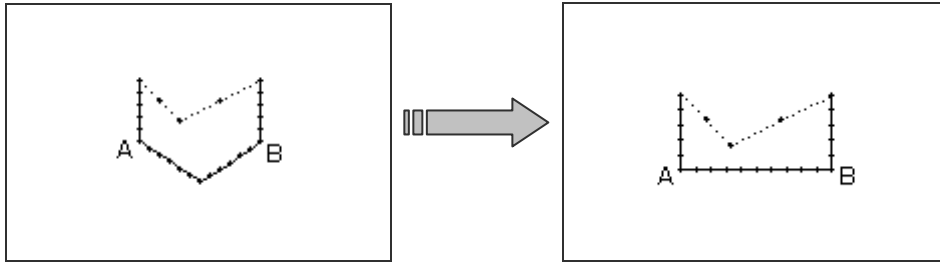

15.Modifying a block 1 (Linear input)

[Example] The section between the A point and B point of the following type of stitching pattern will be modified to a linear line.





Operation details

(1)Selecting block modification

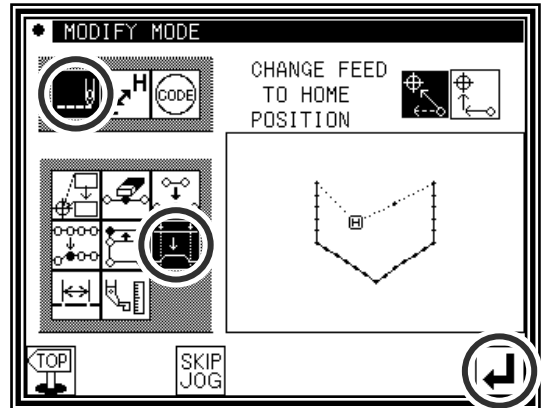
- ▶ Enter the modification mode.
- ▶ Press Stitch Data Change  and Block Modify .
- ▶ Press  to open the next screen.



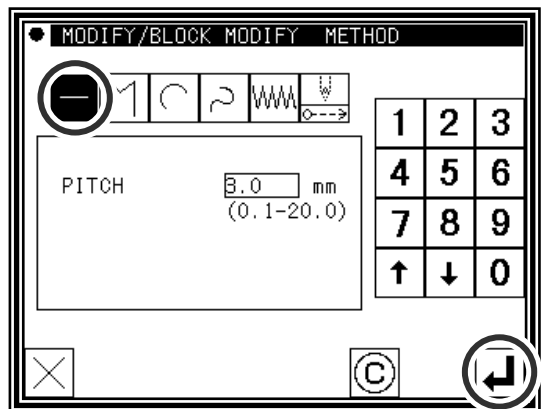

(2)Selecting the input type and the stitch length

- ▶ Press Linear .
- ▶ Set the stitch length. (Set to 3.0mm for this example.)
- ▶ Press  to set the data.



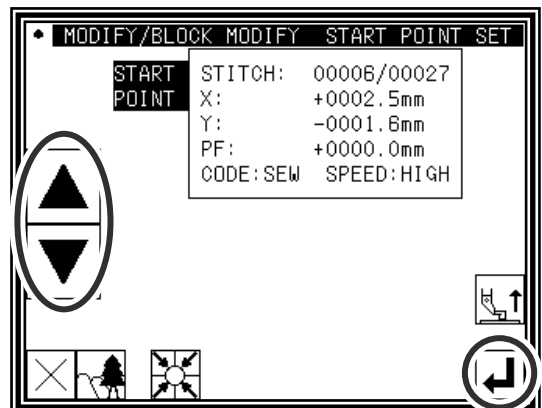

(3)Determining the block modification range (start point)

- ▶ Using Jog , , determine the start point position.(A point)
- ▶ Press .



(4) Determining the block modification range (end point)

► Using Jog , , determine the end point position. (B point)

► Press .

Caution When the end point is determined, the work holder will automatically return to the start point. Take care when the needle is lowered, etc.

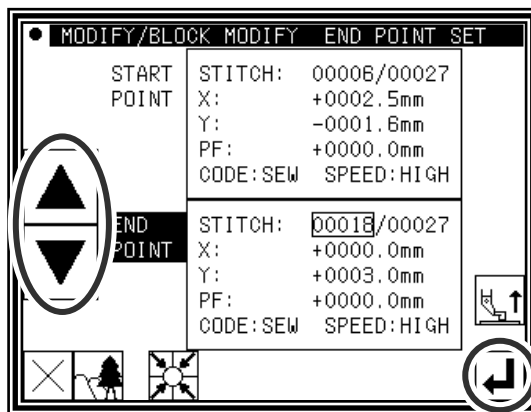

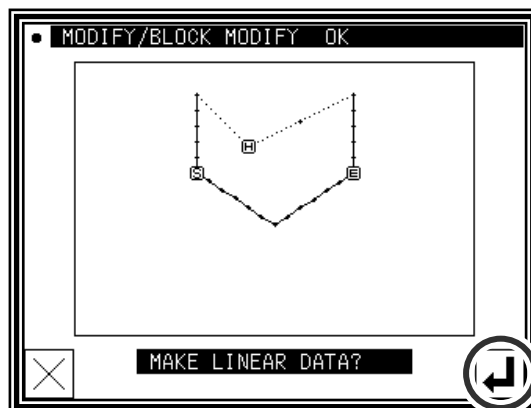

(5) Confirming the data creation

► Press .
(The block position will be modified.)



(6) Confirming the modified data

► Quit the modification mode. Press  to change to the Saving mode screen. Press  to return to the Standard screen after saving the data.
(When  is pressed, the modifications executed last will be undone.)

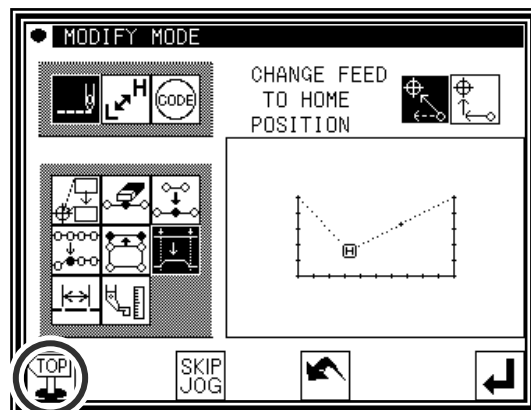

- [Memo] 1. When arc modification is selected for block modification: Arc modification will be executed just by indicating one point in the designated range.
2. When linear modification is selected for block modification: The modification range will be connected with linear lines.
3. If the block to be modified contains code data, the code data will be deleted.
4. The block modification start point and end point are explained below.

■For modification other than feed data modification

The start point can be designated when the stitch is stitching data.

The end point can be designated when the section before the stitch is stitching data.

(Refer to following illustration.)

(The data between the start point and end point is irrelevant. However, the feed data between the start point and end point will be changed to stitching data.)

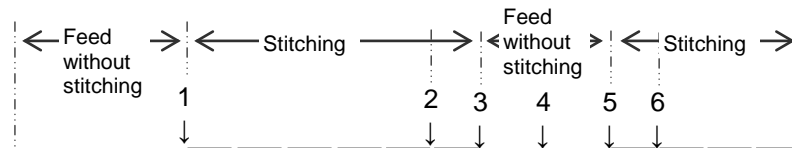

| Start point | End point | Designation validity |
|-------------|-----------|---|
| 1 | - 2 | Valid (OK) |
| 1 | - 3 | Valid (OK) |
| 1 | - 4 | Invalid (NG) ... Prior section is feed data |
| 1 | - 5 | Invalid (NG) ... Prior section is feed data |
| 1 | - 6 | Valid (OK) |

■For feed data modification

The start point can be designated when the stitch is stitching data or feed data.

The end point can be designated when the section before the stitch is stitching data or feed data.

(The data between the start point and end point is irrelevant.)

16.Modifying a block 2 (Broken line, arc, curve input)

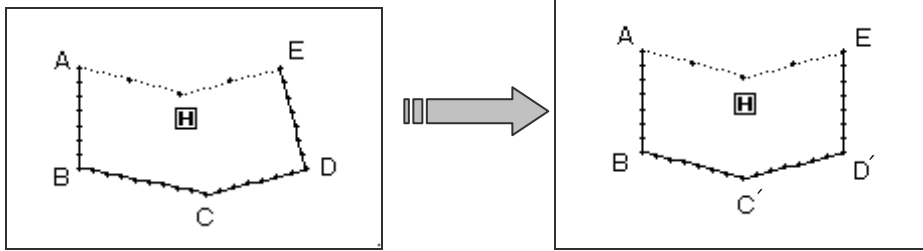

Methods for designating the modification position with the jog icons. (This is handy when using the modification origin data as a reference.)

[Example] The C point and D point in the following type of data are each modified to the C' point and D' point.





Operation details

(1)Selecting block modification

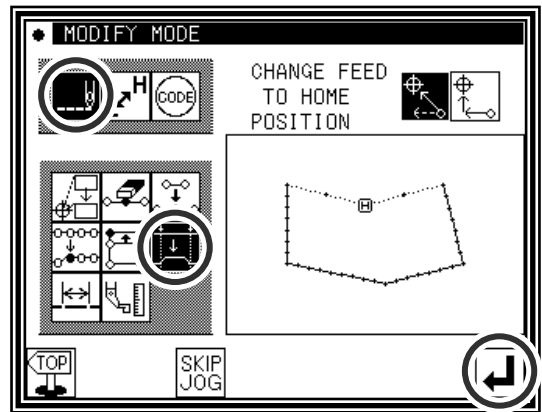
- ▶ Enter the modification mode.
- ▶ Press Stitch Data Change  and Block Modify .
- ▶ Press  to open the next screen.



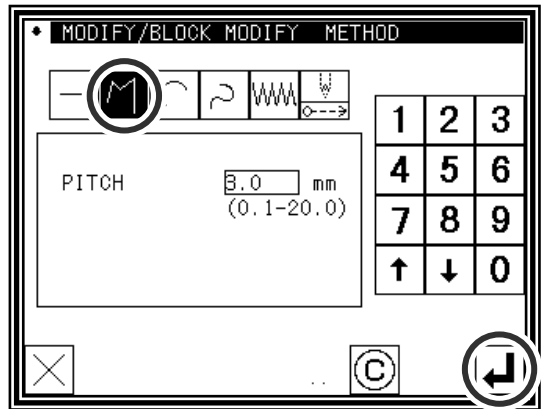

(2)Selecting the input type and the stitch length

- ▶ In this case, press Broken Line .
- ▶ Set the stitch length. (Set to 3.0mm for this example.)
- ▶ Press  to set the data.





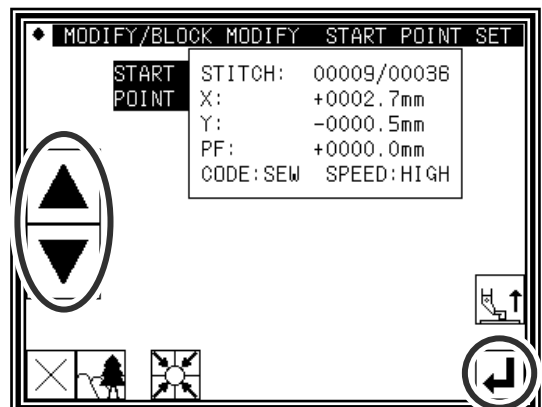

(3)Determining the block modification range (start point)

- ▶ Using Jog , , determine the start point position.(B point)
- ▶ Press .





(4) Determining the block modification range (end point)

- ▶ Using Jog , , determine the end point position. (E point)
- ▶ Press Jog Validity .
- ▶ Press .

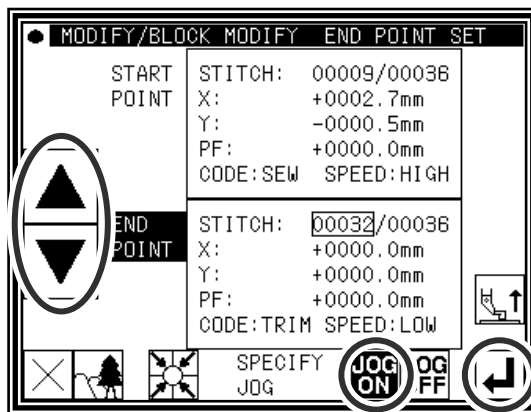
Caution When the end point is determined, the work holder will automatically return to the start point. Take care when the needle is lowered, etc.



(5) Moving and setting the modification origin jog position

- ▶ Using Jog , , move to the position to be modified. (C point in this example.)
- ▶ Press .

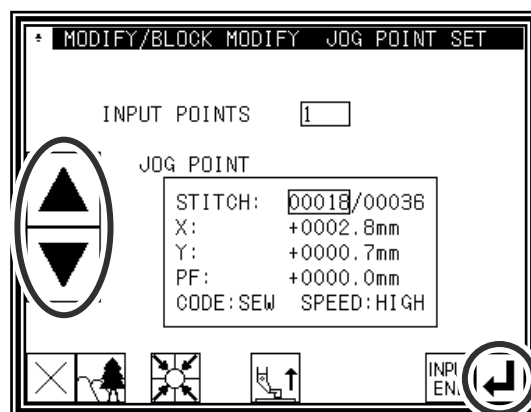



(6) Moving from the modification origin jog position to the modification position, and setting the data

- ▶ Press the arrow icons and modify the position. (Move to the C' point in this example.)
- ▶ Press .

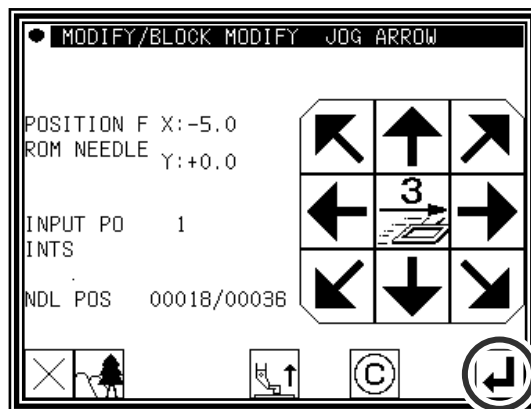
Caution The work holder will automatically return to the modification origin jog position (Needle position specified at (5.)). Take care when the needle is lowered, etc.



(7) Moving and setting the modification origin jog position

- ▶ Using Jog , , move to the position to be modified. (D point in this example.)
- ▶ Press .

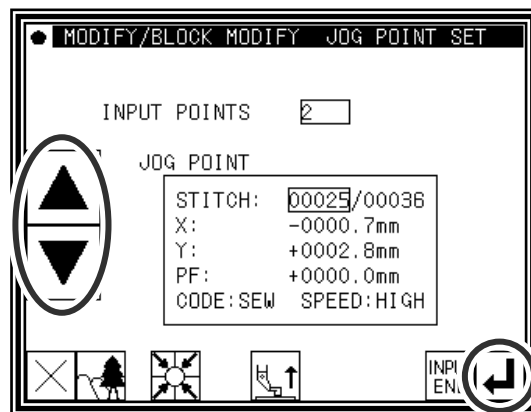

(8) Moving from the modification origin jog position to the modification position, and setting the data

▶ Press the arrow icons and modify the position. (Move to the D' point in this example.)

▶ Press .

Caution The work holder will automatically return to the modification origin jog position (Needle position specified at (5.)). Take care when the needle is lowered, etc.

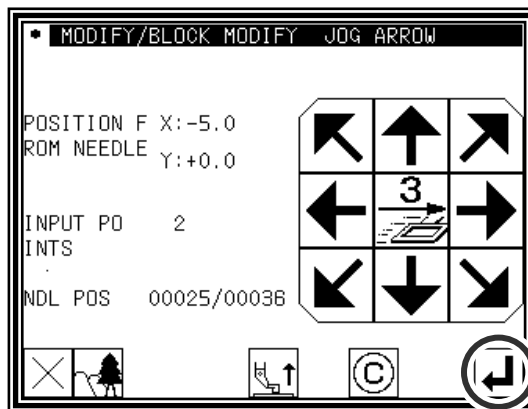

(9) Quitting position modification

▶ After determining all modification positions, press

.

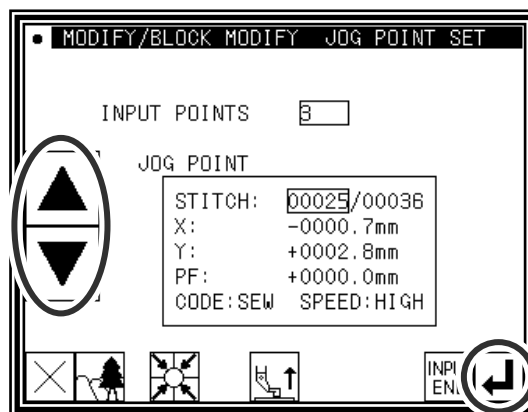



(10) Confirming the data creation

▶ To create the data, press  (The block position will be modified.)

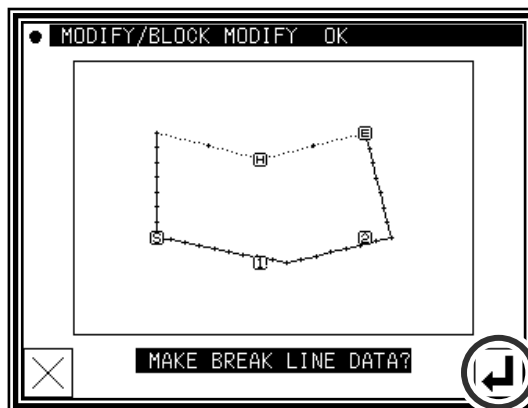
Caution The work holder will automatically return to the start point. Take care when the needle is lowered, etc.



(11) Confirming the modified data

▶ Quit the modification mode. Press  to change to the Saving mode screen. Press  to return to the Standard screen after saving the data. (When  is pressed, the modifications executed last will be undone.)

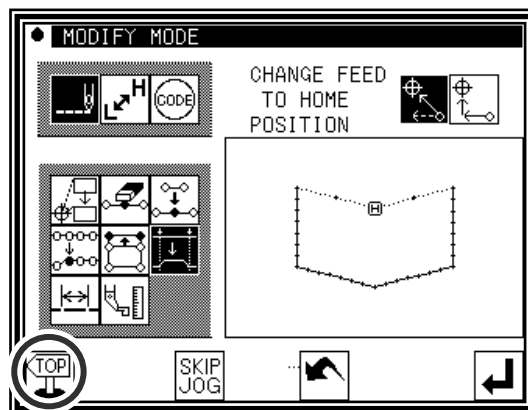

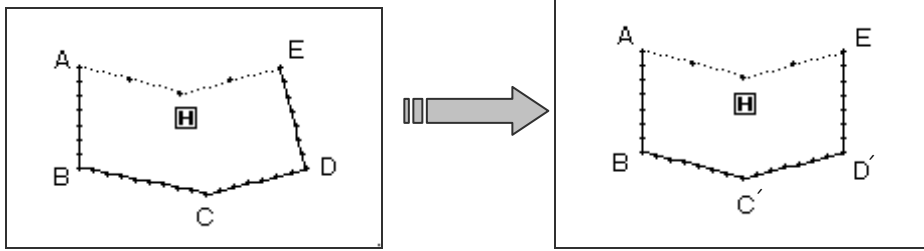

■ Designating the modification position without using jog icons (Handy for newly creating data.)

[Example] The C point and D point in the following type of data are each modified to the C' point and D' point.





Operation details

(1) Selecting block modification

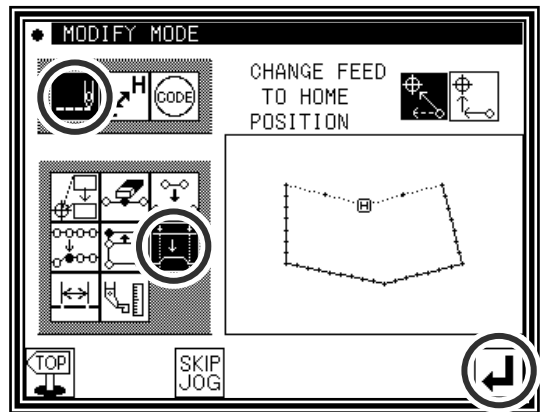
- ▶ Enter the modification mode.
- ▶ Press Stitch Data Change  and Block Modify .
- ▶ Press  to open the next screen.



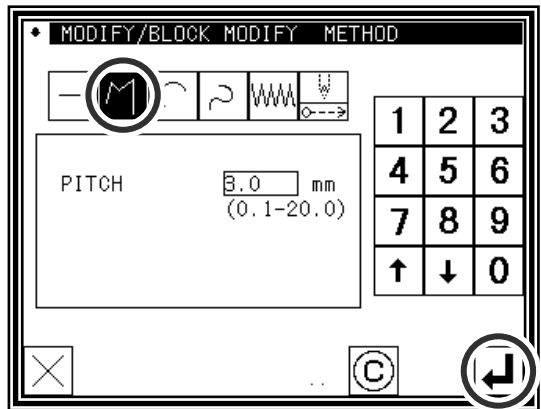

(2) Selecting the input type and the stitch length

- ▶ In this case, press Broken Line .
- ▶ Set the stitch length. (Set to 3.0mm for this example.)
- ▶ Press  to set the data.



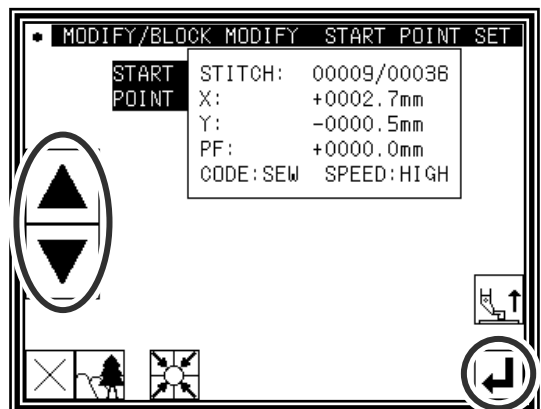

(3) Determining the block modification range (start point)

- ▶ Using Jog , , determine the start point position.(B point)
- ▶ Press .



(4) Determining the block modification range

▶ Using Jog  ,  , determine the start point(B point) and end point(E point).

▶ Press Jog Validity .

▶ Press .

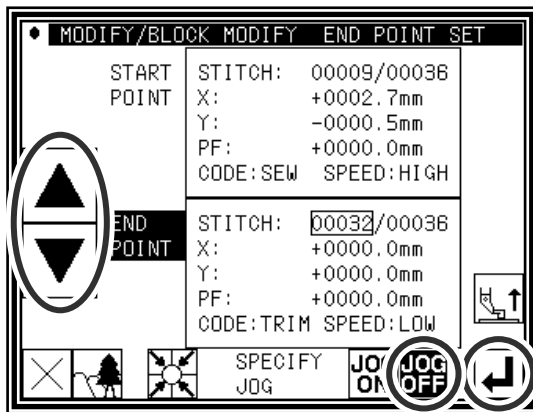

Caution When the end point is determined, the work holder will automatically return to the start point. Take care when the needle is lowered, etc.

(5) Moving and determining the modification position

▶ Using the arrow icons, modify the position. (Move to C point in this example.)

▶ Press .

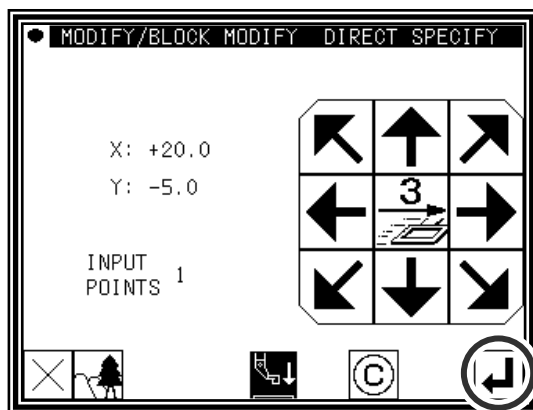

(6) Moving and determining the modification position

▶ Using the arrow icons, modify the position. (Move to D' point in this example.)

▶ Press .

▶ press  again.

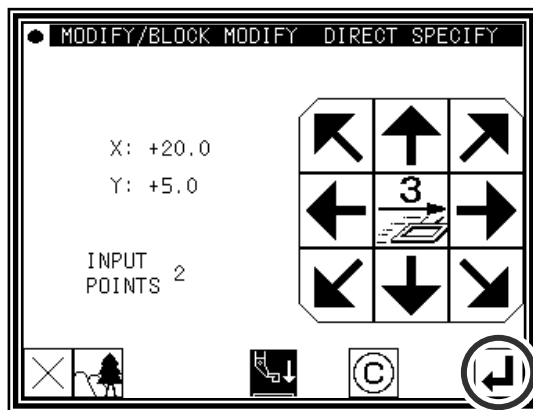



(7) Confirming the data creation

▶ To create the data, press  .
(The block position will be modified.)

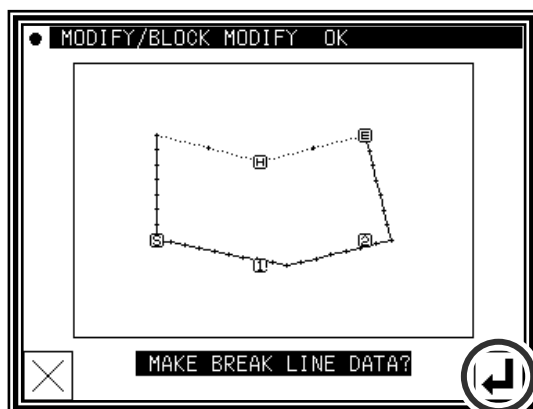
Caution The work holder will automatically return to the start point. Take care when the needle is lowered, etc.



(8) Confirming the modified data

- Quit the modification mode. Press  to change to the Saving mode screen. Press  to return to the Standard screen after saving the data. (When  is pressed, the modifications executed last will be undone.)

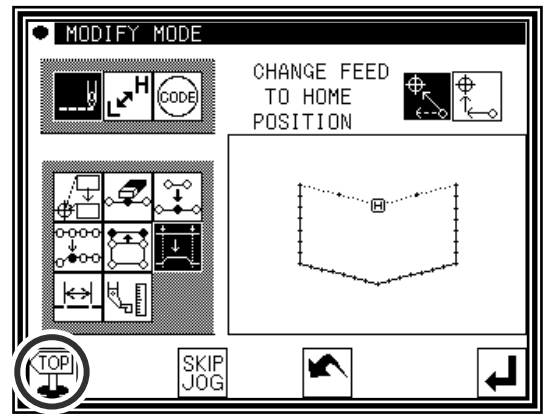

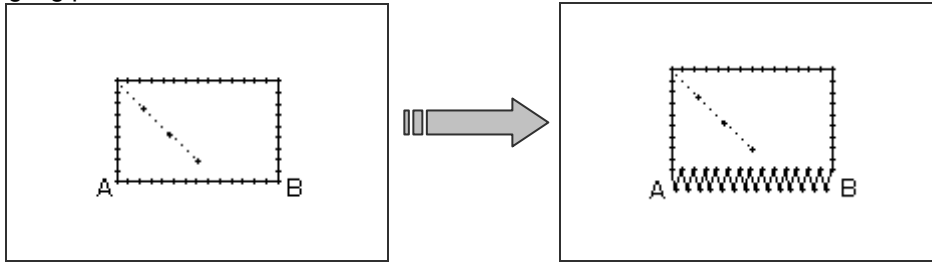

17.Modifying a block 3 (Zigzag input)

[Example] The section between the A point and B point in the following type of stitching data is modified to a zigzag pattern.



Operation details

(1)Selecting block modification

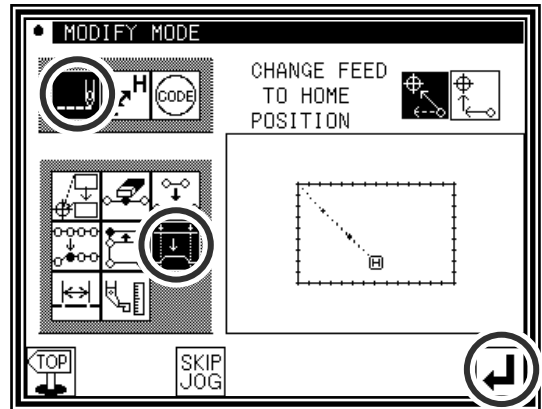

- ▶ Enter the modification mode.
- ▶ Press Stitch Data Change  and Block Modify .
- ▶ Press  to open the next screen.



(2)Selecting the input type



- ▶ Press Zigzag .
- ▶ Set the deflection width, feed amount and creation direction.
Set the deflection width to 5.0mm, feed amount to 3.0mm, and the creation direction to right (R).

Memo Refer to "[7] Methods of creating stitching data (12)Zigzag stitching (with overlap back tacking)" for details on the deflection width, feed amount and creation direction.

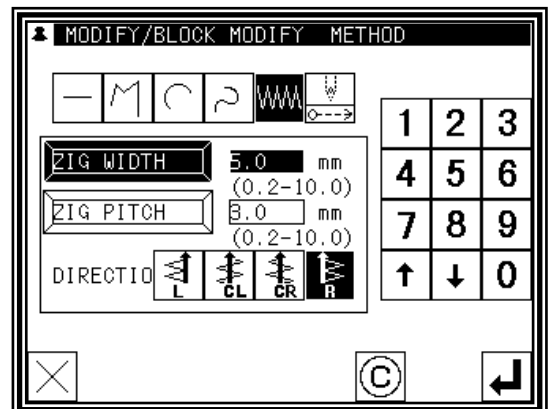
- ▶ Press  to set the data. (At this time, if  is pressed, the deflection width and feed amount settings will be canceled.)



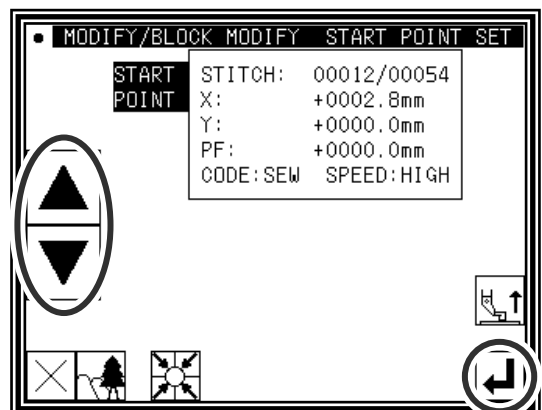

(3)Determining the block modification range (start point)

- ▶ Using Jog , , determine the start point position.(A point)
- ▶ Press .



(4) Determining the block modification range (end point)

► Using Jog , , determine the end point position. (B point)

► Press .

Caution When the end point is determined, the work holder will automatically return to the start point. Take care when the needle is lowered, etc.

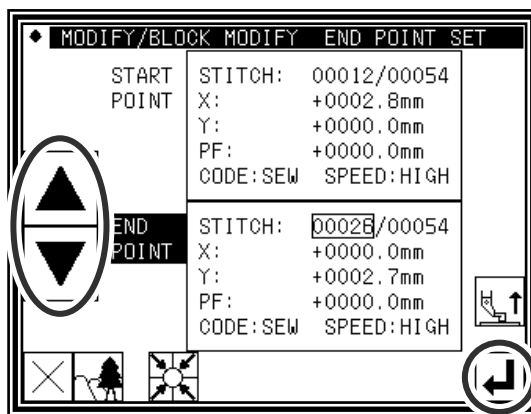

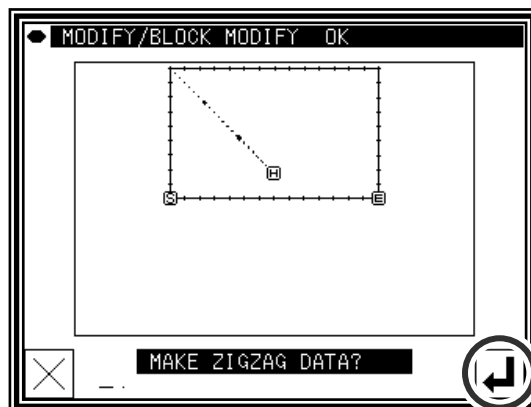

(5) Confirming the data creation

► To create the data, press .
(The block position will be modified.)



(6) Confirming the modified data

► Quit the modification mode. Press  to change to the Saving mode screen. Press  to return to the Standard screen after saving the data.
(When  is pressed, the modifications executed last will be undone.)

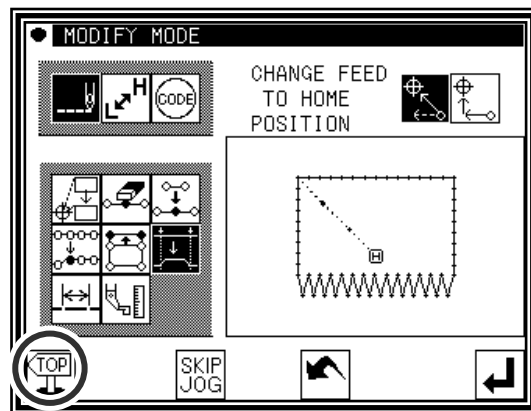

18.Modifying a block 4 (Changing the feed data)

Methods for designating the modification position with the jog icons.

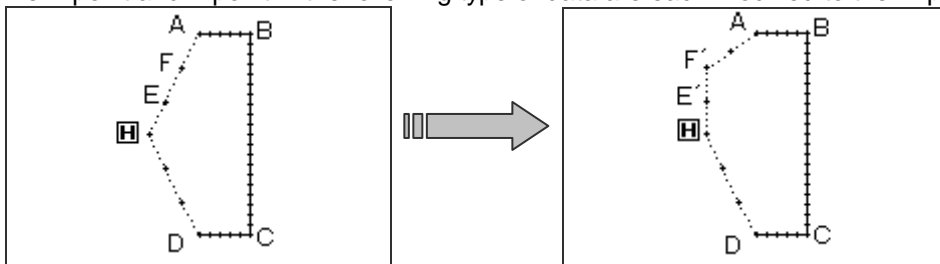

(This is handy when using the modification origin data as a reference.)

[Example] The E point and F point in the following type of data are each modified to the E' point and F' point.



Operation details

(1)Selecting block modification

- ▶ Enter the modification mode.
- ▶ Press Stitch Data Change  and Block Modify .
- ▶ Press  to open the next screen.

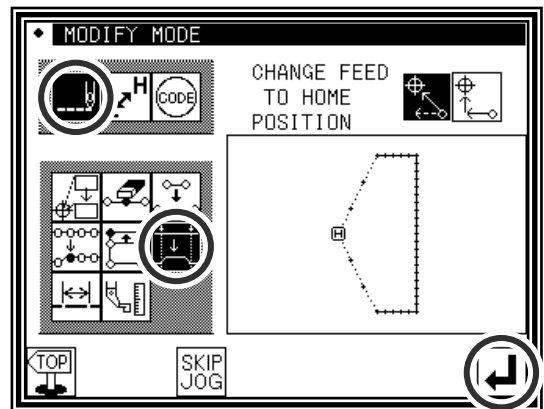

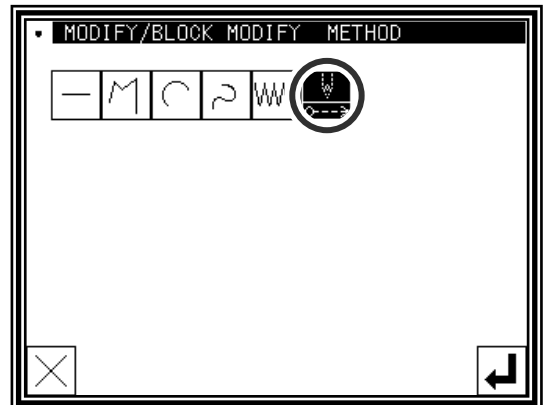

(2)Selecting the input type

- ▶ Press Feed data .
- ▶ Press  to set the data.





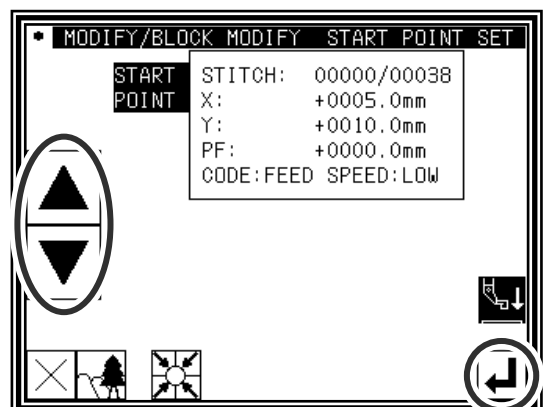

(3)Determining the block modification range (start point)

- ▶ Using Jog , , determine the start point position. (Home position)
- ▶ Press .





(4) Determining the block modification range (end point)

- ▶ Using Jog  ,  , determine the end point position.(A point)
- ▶ Press Jog Validity  .
- ▶ Press  .

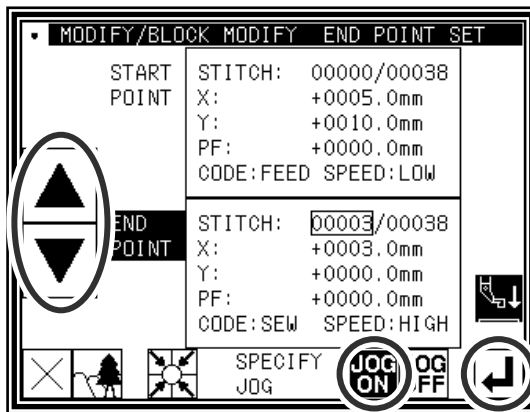
Caution When the end point is determined, the work holder will automatically return to the start point. Take care when the needle is lowered, etc.



(5) Moving and setting the modification origin jog position

- ▶ Using Jog  ,  , move to the position to be modified. (E point in this example.)
- ▶ Press  .

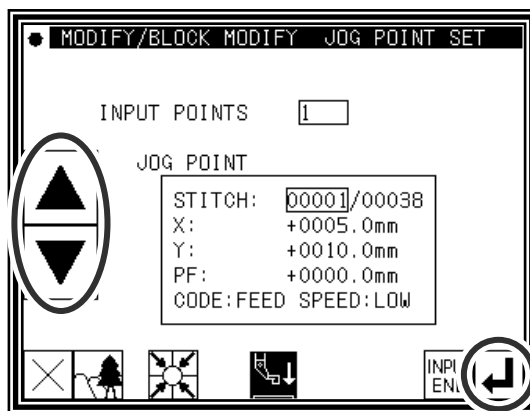



(6) Moving from the modification origin jog position to the modification position, and setting the data

- ▶ Press the arrow icons and modify the position. (Move to the E' point in this example.)
- ▶ Press  .

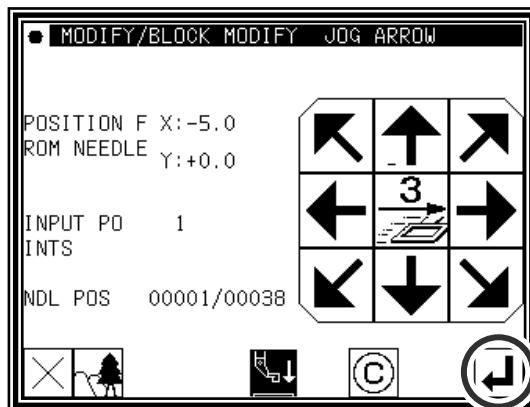
Caution The work holder will automatically return to the modification origin jog position. Take care when the needle is lowered, etc.



(7) Moving and setting the modification origin jog position

- ▶ Using Jog  ,  , move to the position to be modified. (F point in this example.)
- ▶ Press  .

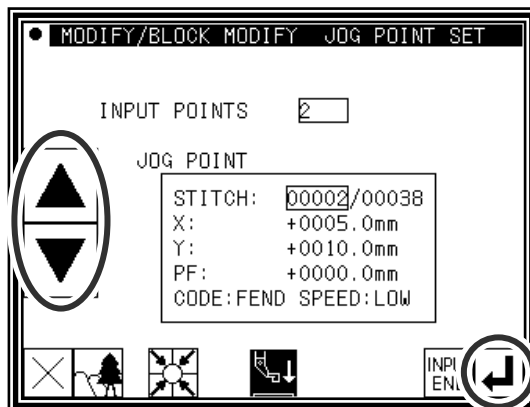

(8) Moving from the modification origin jog position to the modification position, and setting the data

▶ Press the arrow icons and modify the position.
(Move to the F' point in this example.)

▶ Press .

Caution The work holder will automatically return to the modification origin jog position. Take care when the needle is lowered, etc.

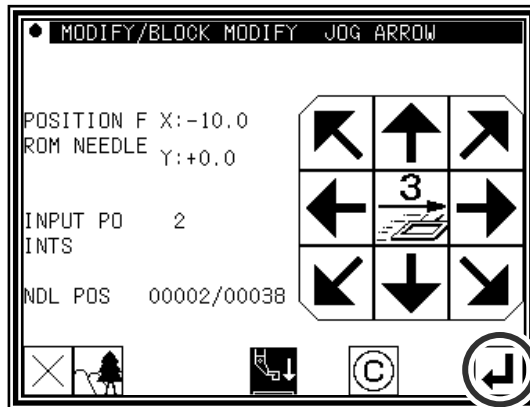

(9) Quitting position modification

▶ After determining all modification positions, press .

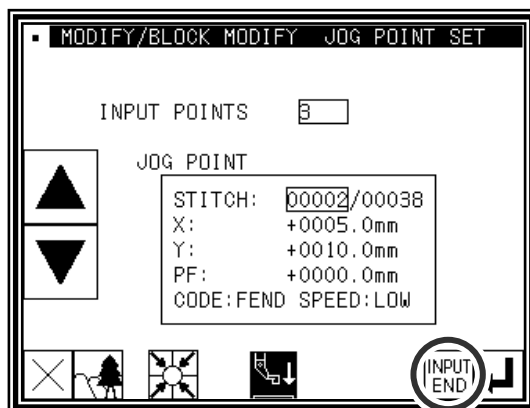

(10) Confirming the data creation



▶ Press .

(The block position will be modified.)

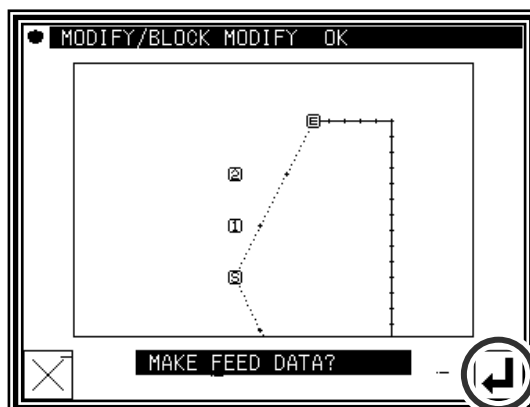
Caution The work holder will automatically return to the start point. Take care when the needle is lowered, etc.



(11) Confirming the modified data

▶ Quit the modification mode. Press  to change to the Saving mode screen. Press  to return to the Standard screen after saving the data.
(When  is pressed, the modifications executed last will be undone.)

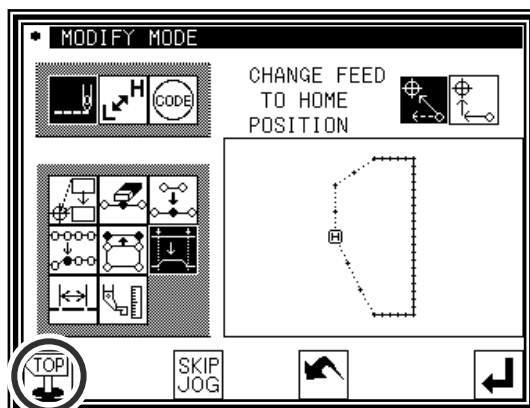

■ Designating the modification position without using jog icons

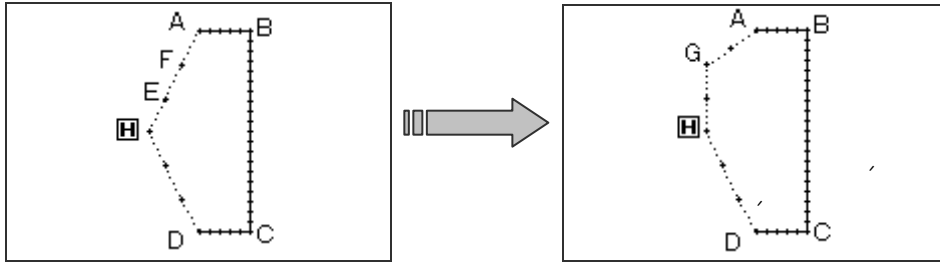

(Handy for newly creating data.)

[Example] The E point and F point in the following type of stitching data will be deleted, the G point will be newly created, and the feed data will be modified.



Operation details

(1) Selecting block modification

- ▶ Enter the modification mode.
- ▶ Press Stitch Data Change  and Block Modify .
- ▶ Press  to open the next screen.

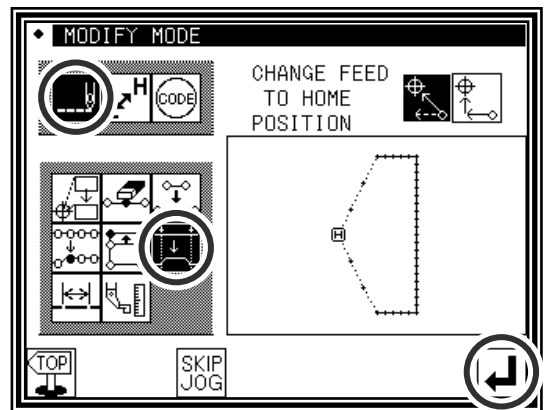

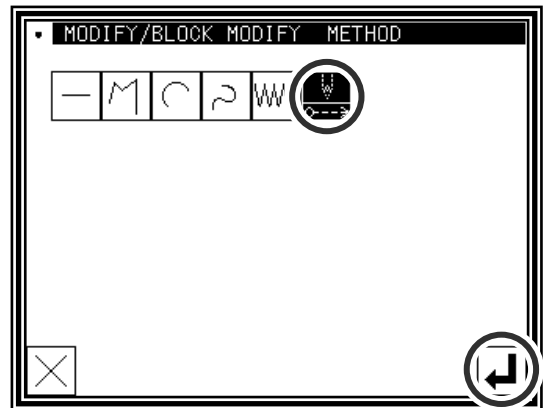

(2) Selecting the input type

- ▶ Press Feed data .
- ▶ Press  to set the data.





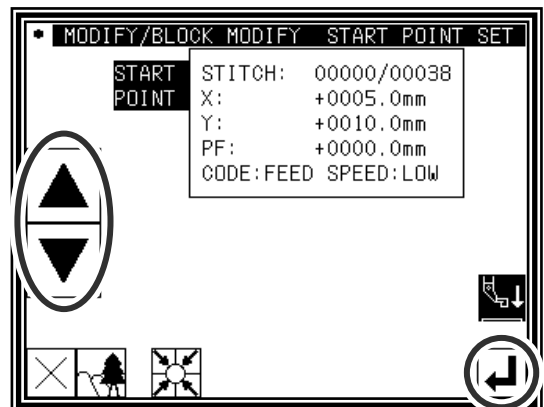

(3) Determining the block modification range (start point)

- ▶ Using Jog , , determine the start point position. (Home position)
- ▶ Press .



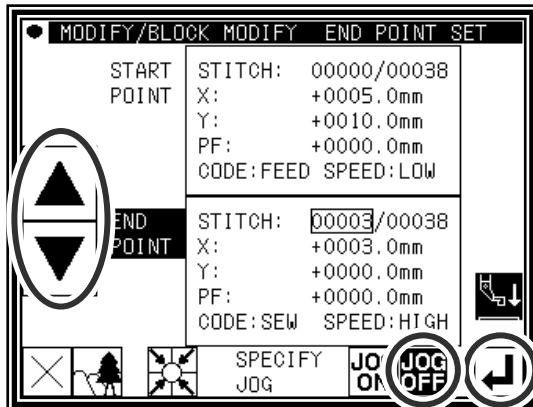

(4) Determining the block modification range

- ▶ Using Jog  ,  , determine the start point(Home position) and end point(A point).
- ▶ Press Jog Validity  .
- ▶ Press  .



(5) Moving and determining the modification position

- ▶ Using the arrow icons, modify the position. (Move to G point in this example.)
- ▶ Press  .
- ▶ If there are several positions to be modified, repeat step 5. (The number of input points will increase.)
- ▶ When all modifications have been made, press  again.

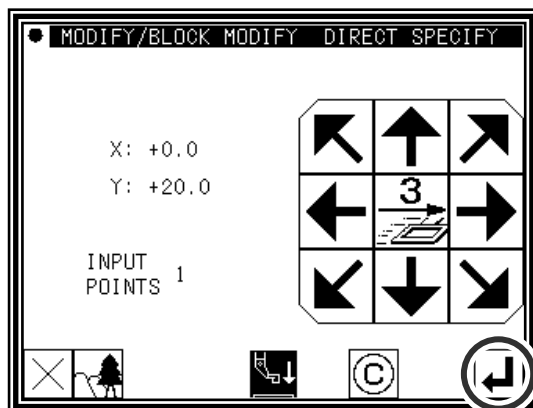



(6) Confirming the data creation

- ▶ Press  .
(The block position will be modified.)

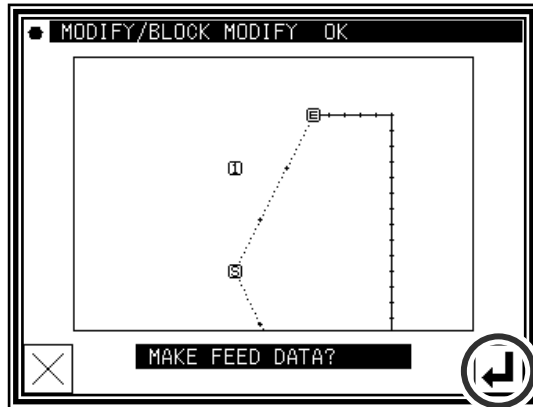
Caution The work holder will automatically return to the start point. Take care when the needle is lowered, etc.



(7) Confirming the modified data

- ▶ Quit the modification mode. Press  to change to the Saving mode screen. Press  to return to the Standard screen after saving the data.
(When  is pressed, the modifications executed last will be undone.)

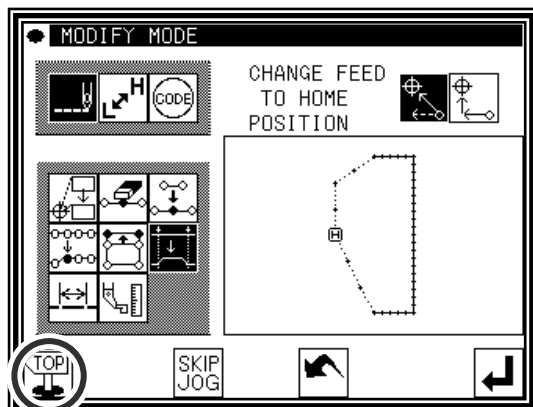

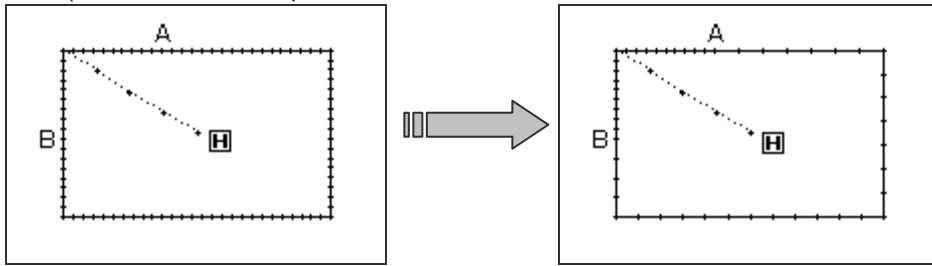

19.Modifying stitch length (Designated distance modification)

[Example] The stitch length between the stitching data point A and point B is modified as shown below.
(3.0mm → 7.0mm)







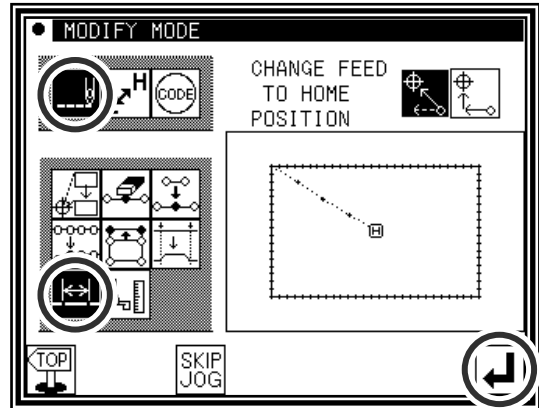

Operation details

(1)Selecting the stitch length modification

- ▶ Enter the modification mode.
- ▶ Press Stitch Data Change  and
Stitch length modification .
- ▶ Press  to open the next screen.



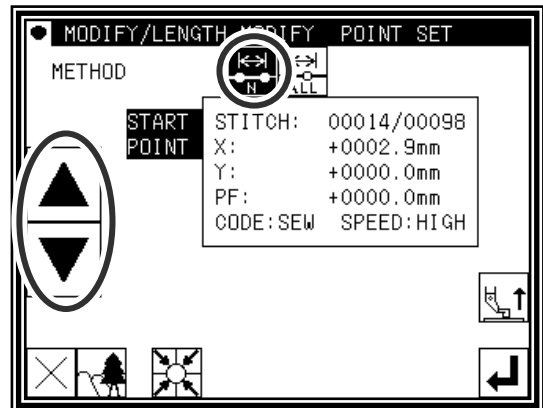

(2)Determining the modification method and the modification start position

- ▶ Set the method.
 : Designated distance modification
 : All After designated stitch
 (In this case, press )
- ▶ Determine the position to be modified with jog  . Set to the position to start modification (point A).
- ▶ Press .



(3)Determining the modification end position

- ▶ Determine the position to be modified with jog  . Set to the position to end modification (point B).
- ▶ Press .

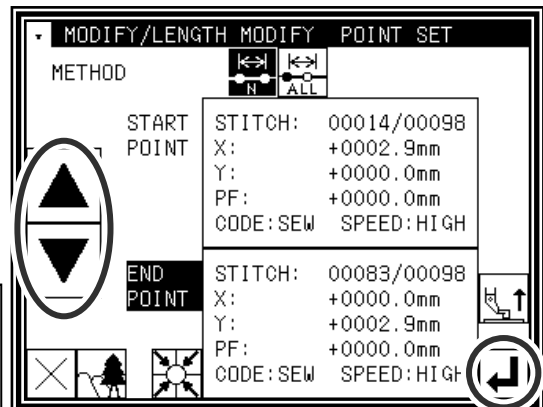

Caution When the end point is determined, the work holder will automatically return to the start point. Take care when the needle is lowered, etc.



(4) Setting the stitch length and confirming execution

▶ Set the stitch length. (This will be "7.0mm" here.)

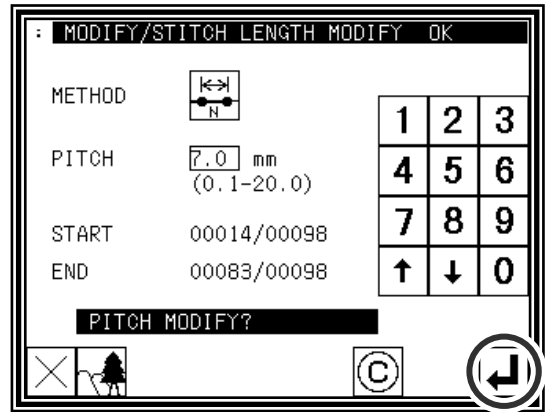
▶ Press .



(5) Confirming the modifications

▶ Quit the modification mode. Press  to change to the Saving mode screen. Press  to return to the Standard screen after saving the data.

(When  is pressed, the modifications executed last will be undone.)

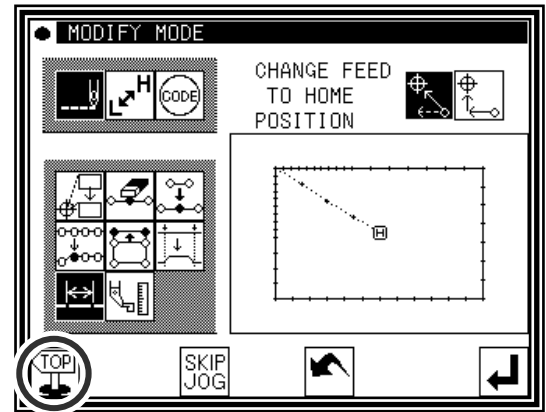

(6) Confirming with the Standard screen

▶ The stitch length has been modified.

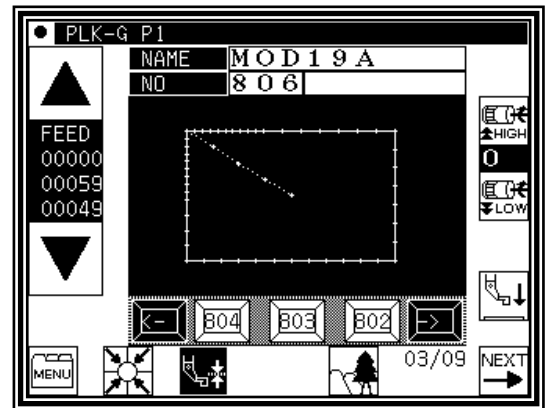

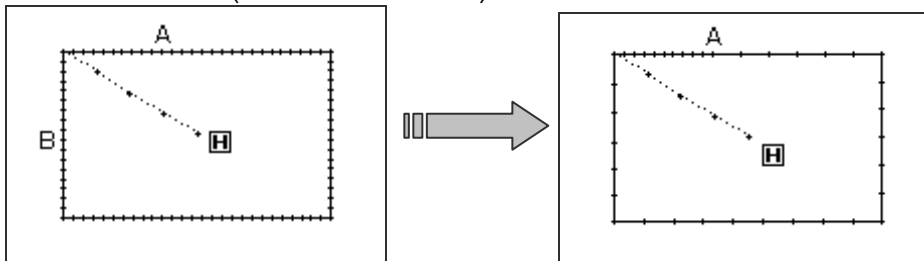

20.Modifying stitch length (All After designated stitch)

[Example] The stitch length from stitching data point A to the end of stitching is modified as shown below. (3.0mm → 9.0mm)







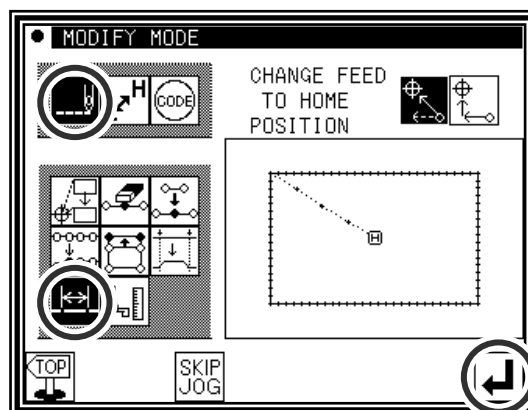

Operation details

(1)Selecting the stitch length modification

- ▶ Enter the modification mode.
- ▶ Press Stitch Data Change  and
Stitch length modification .
- ▶ Press  to open the next screen.



(2)Determining the modification method and the modification start position

- ▶ Set the method.
 -  : Designated distance modification
 -  : All After designated stitch
 (In this case, press )
- ▶ Determine the position to be modified with jog  . Set to the position to start modification (point A).
- ▶ Press .

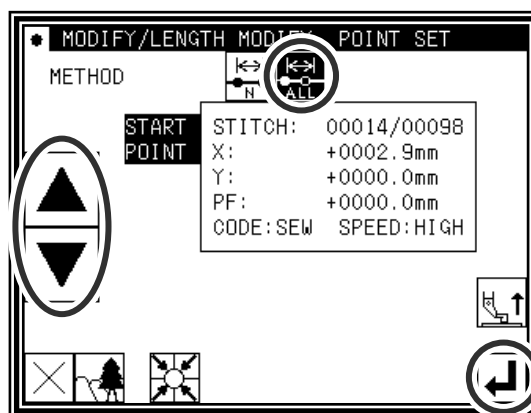

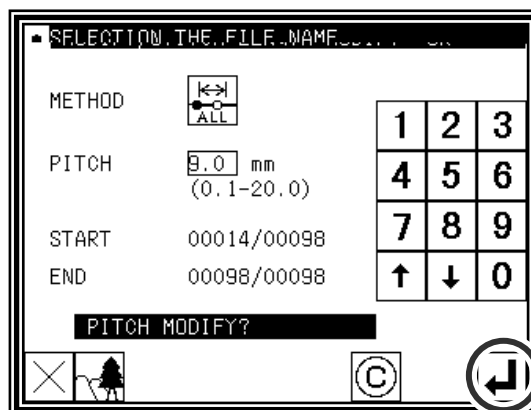

(3)Setting the stitch length and confirming execution

- ▶ Set the stitch length. (This will be "9.0mm" here.)
- ▶ Press .



(4) Confirming the modifications

- ▶ Quit the modification mode. Press  to change to the Saving mode screen. Press  to return to the Standard screen after saving the data. (When  is pressed, the modifications executed last will be undone.)

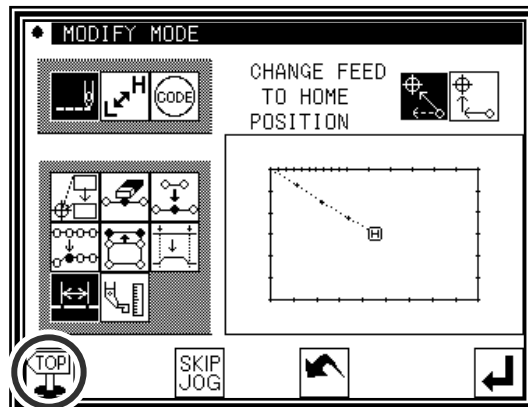

(5) Confirming with the Standard screen

- ▶ The stitch length has been modified.

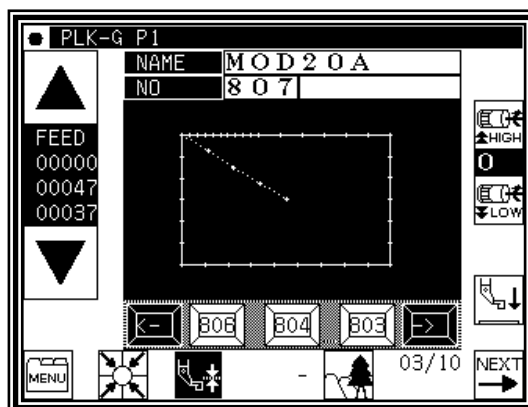

21. Modifying material step

[example] In the pattern data like a figure below, it is modified that the presser foot will be raised by 1.6 mm between A point and B point.

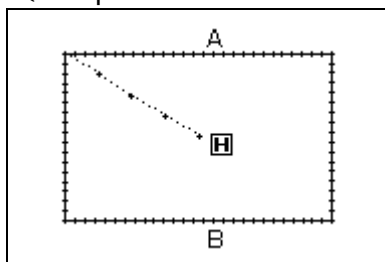

(The presser foot correction value is already set to 3.0 mm)



Detailed operation

(1) Selection material step modification



▶ Enter the pattern modification mode (Refer to P.[11]-1)

▶ Press the stitch modification  then, press the material step modification .

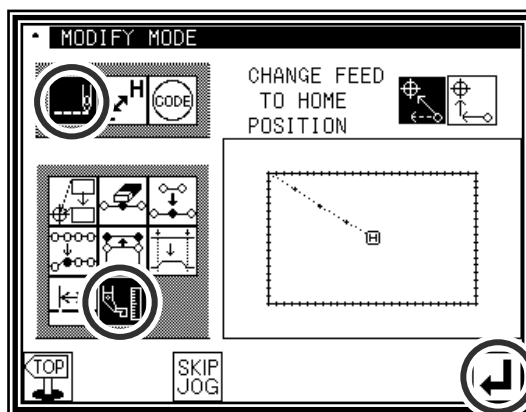
▶ Press .



(2) Moving to designated stitch position (A point)

▶ Move X-Y table to A point by pressing  .

▶ After move to the position, press .

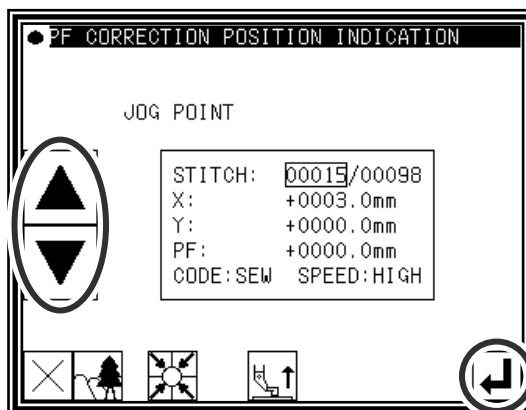



(3) Setting correction value

▶ Change material thickness to [1.6] by pressing up and down arrow.

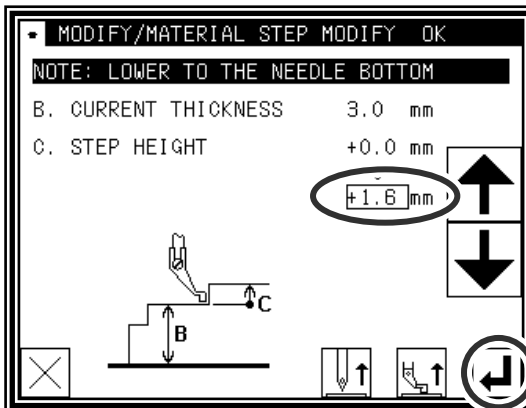
▶ After setting, press .



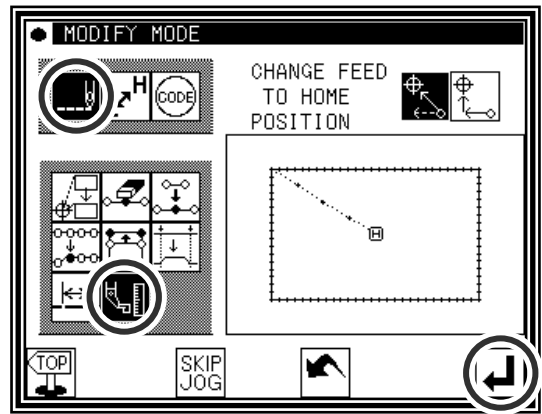

(4) Moving to designated stitch position

- ▶ Press  then, .
- ▶ Press .



(5) Moving to designated stitch position (B point)

- ▶ Move X-Y table to B point by pressing  .
- ▶ After move to the position, press .

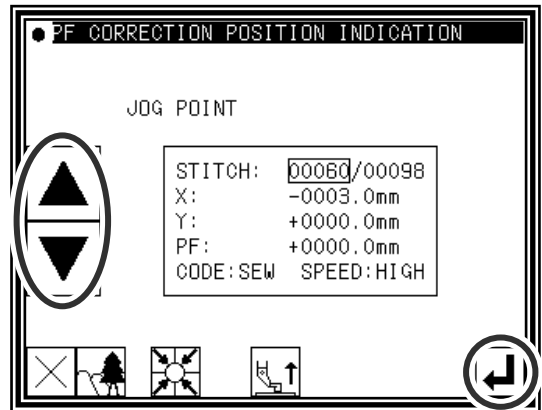

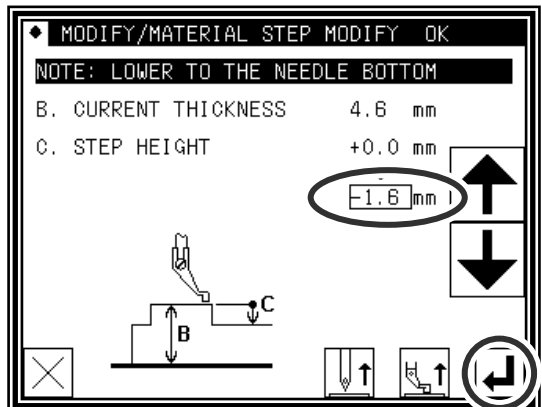

(6) Setting correction value

- ▶ Change material thickness to [-1.6] by pressing up and down arrow.
- ▶ After setting, press .



(7) Finishing material step correction

- ▶ Press  to exit correction mode. Then screen is changed to save mode. Press  after data is saved, then screen is backed to standard screen. (If  is pressed, pattern data is returned to former state)

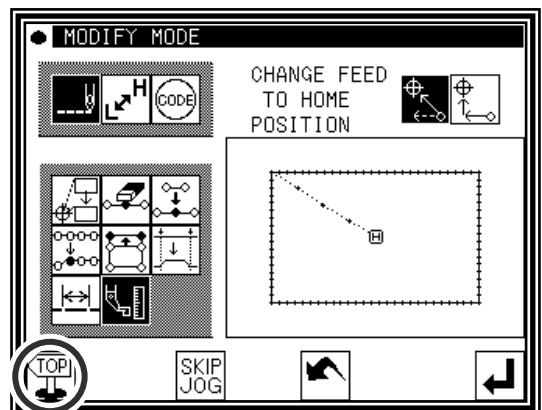

(8) Back to the standard screen

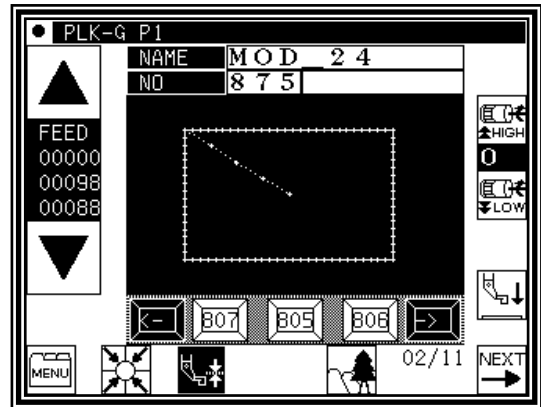

- ▶ Material step has been modified.

(The presser foot motion can be checked by the JOG icon)



(9) Check the correction

- ▶ Enter the modification mode. (Refer to P.[11]-1)

▶ Press , then .

▶ Press .

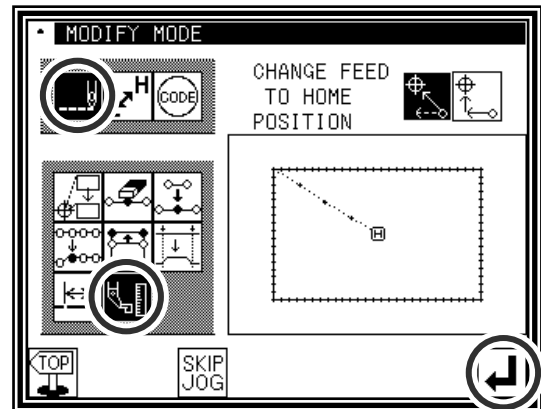

(10) Moving to modified stitch position

- ▶ Move to designated position (A point) by pressing  .

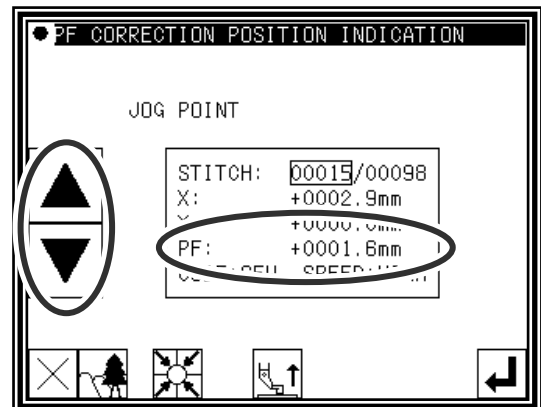

- ▶ The value of [PF:] has been [+0001.6 mm].



(11) Moving to next modified stitch position

- ▶ Move to designated position (B point) by pressing  .

- ▶ The value of [PF:] has been [-0001.6 mm].

- ▶ After check, press  to exit modification mode, then press  to return to standard screen.

- ▶ Checking material step modification is complete.

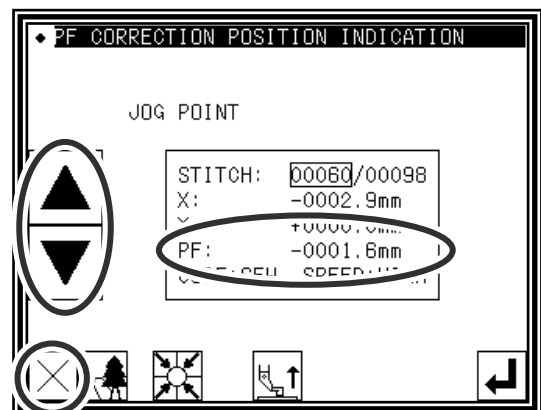

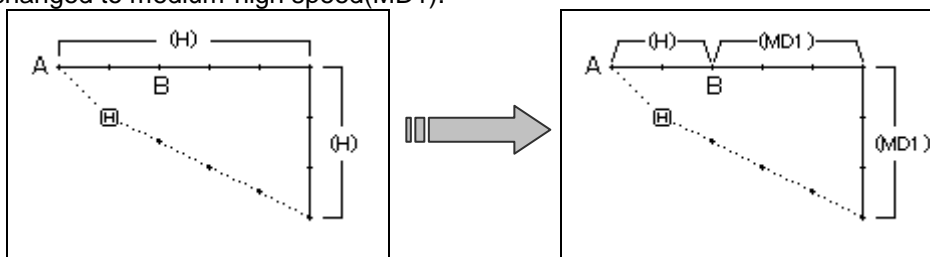

22.Modifying the stitching speed (All sections after designated position)

[Example] The stitching speed for all sections after the B point in the following type of stitching data will be changed to medium-high speed(MD1).





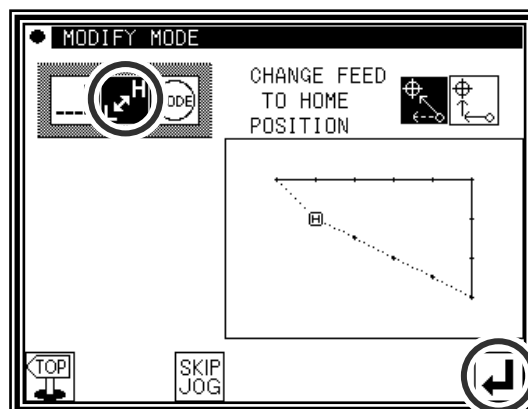

Operation details

(1)Selecting stitching speed modification

- ▶ Enter the modification mode.
- ▶ Press Stitching Speed Change .
- ▶ Press  to open the next screen.



(2)Determining the modification method and the modification start position

- ▶ Press All After Designated Stitch .
- ▶ Using Jog , , determine the start point position to be modified(B point).
- ▶ Press  after determining the positions.

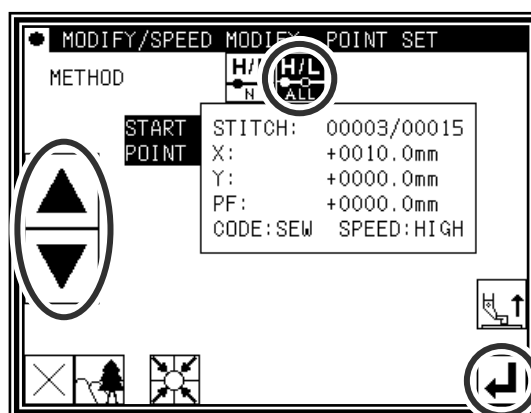

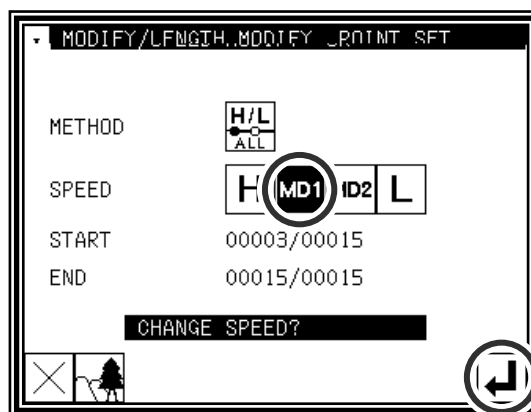

(3)Setting the speed and confirming execution

- ▶ Set the new speed (MD1).
 - ▶ Press .
- (The stitching speed will be modified.)



(4) Confirming the modifications

- ▶ Quit the modification mode. Press  to change to the Saving mode screen. Press  to return to the Standard screen after saving the data. (When  is pressed, the modifications executed last will be undone.)

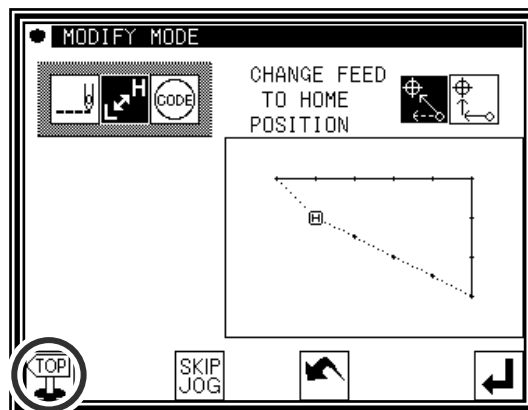

23.Modifying the stitching speed (N stitches after designated position)

[Example] The stitching speed for three stitches from the B point to the C point in the following type of stitching data will be changed to medium-high speed(MD1).

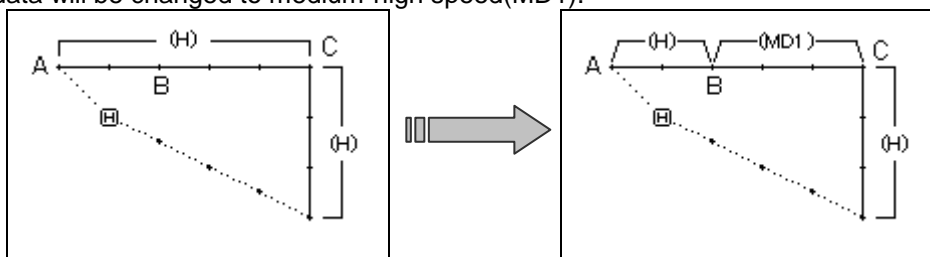

Operation details

(1)Selecting stitching speed modification

- ▶ Enter the modification mode.
- ▶ Press Stitching Speed Change
- ▶ Press

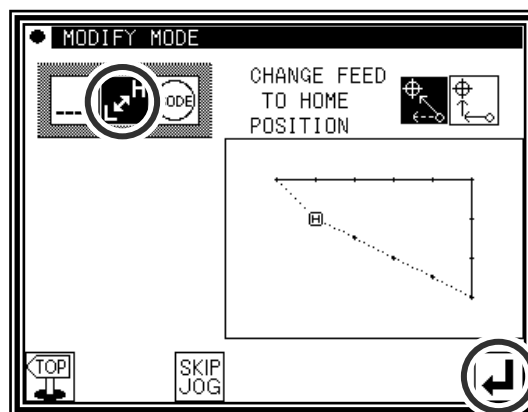

(2)Determining the modification position and the modification range (start point)

- ▶ Press N Stitches Change After Modified
Stitch
- ▶ Using Jog , , determine the start point position to be modified.(B point)
- ▶ Press

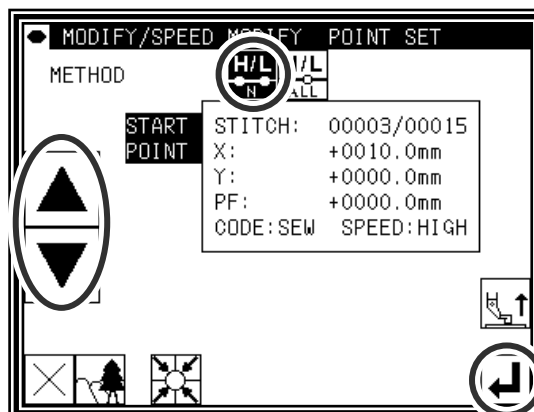

(3)Determining the modification range (end point)

- ▶ Using Jog , , determine the end point position to be modified.(C point)
- ▶ Press

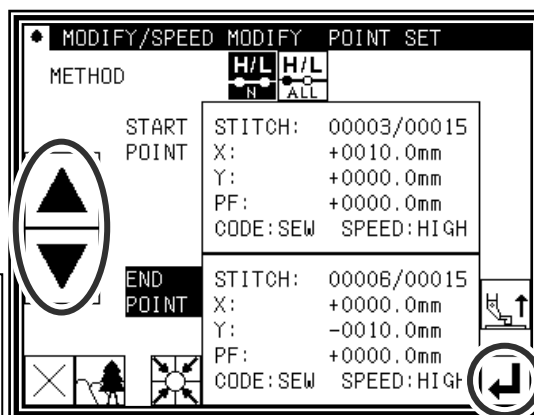



Caution When the end point is determined, the work holder will automatically return to the start point. Take care when the needle is lowered, etc.

(4) Setting the speed and confirming execution

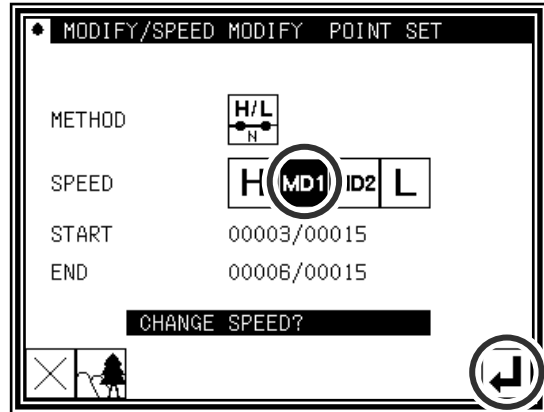
- ▶ Set the new speed (MD1).
- ▶ Press .
(The stitching speed will be modified.)



(5) Confirming the modifications

- ▶ Quit the modification mode. Press  to change to the Saving mode screen. Press  to return to the Standard screen after saving the data.
(When  is pressed, the modifications executed last will be undone.)

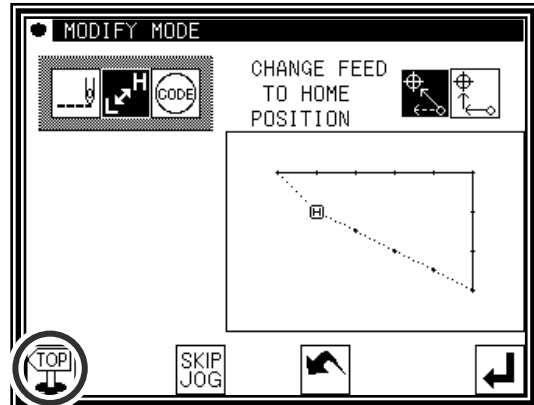

24.Modifying code data (Adding code data)

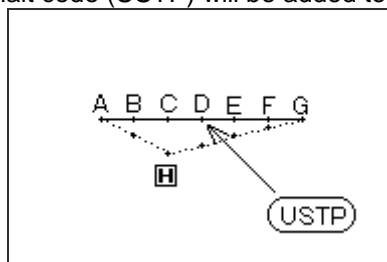

Memo Refer to "Code data input" for a list of code data. [7]-21

[Example] The needle UP halt code (USTP) will be added to the D point of the following type of stitching data.





Operation details

(1)Selecting code data addition

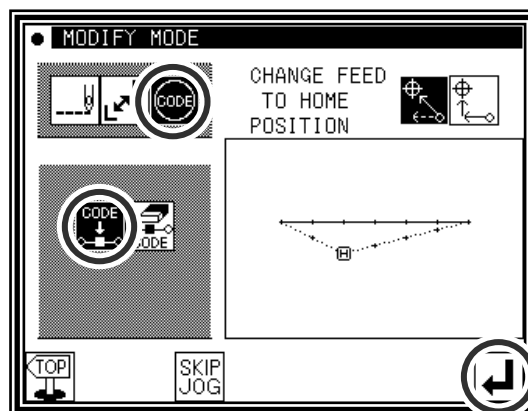
- ▶ Enter the modification mode.
- ▶ Press Code Data Change , and then press Code Data Add .
- ▶ Press  to open the next screen.



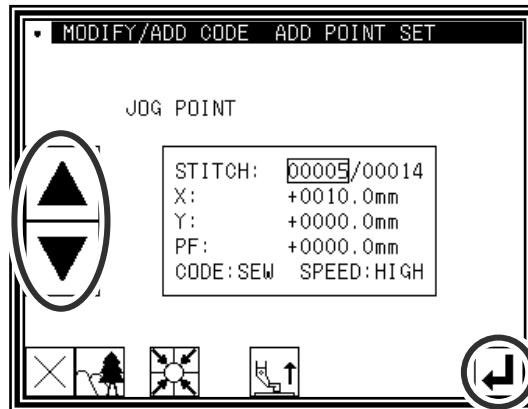

(2)Determining the code addition position

- ▶ Using Jog , , determine the position to add the code.(D point)
- ▶ Press  after determining the position.

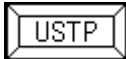

(3)Setting the code to add

- ▶ Press Needle UP Halt .
- ▶ Press .

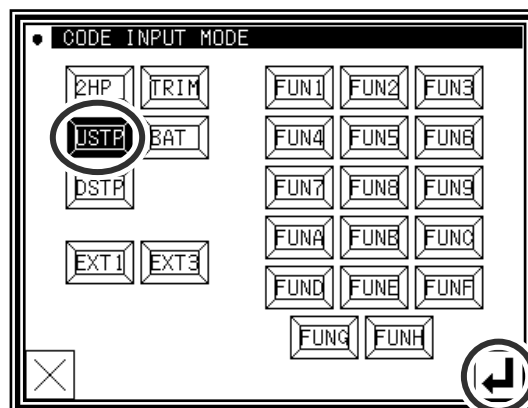

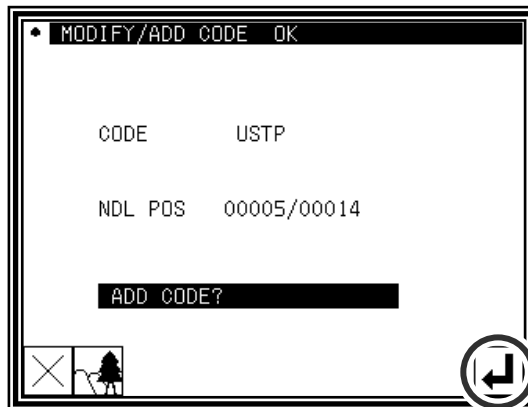

(4) Confirming execution

- ▶ Press .
(The code data will be added.)



(5) Confirming the modifications

- ▶ Quit the modification mode. Press  to change to the Saving mode screen. Press  to return to the Standard screen after saving the data.
(When  is pressed, the modifications executed last will be undone.)

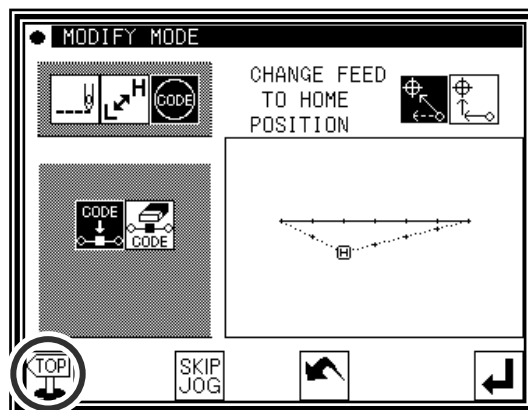

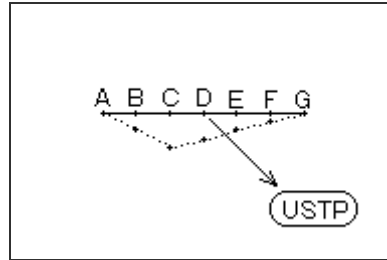

25.Modifying code data (Deleting code data)

[Example] The needle UP halt code (USTP) will be deleted from the D point of the following type of stitching data.





Operation details

(1)Selecting code data deletion

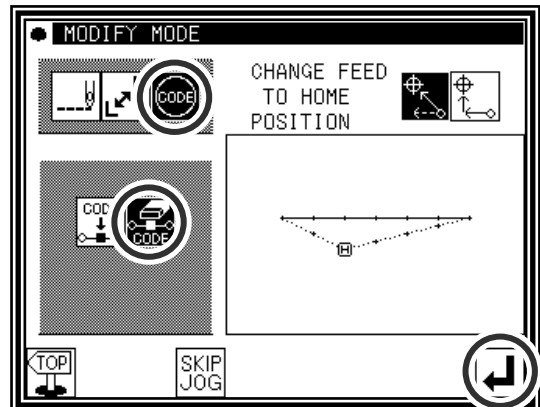
- ▶ Enter the modification mode.
- ▶ Press Code Data Change , and then press Code Data Delete .
- ▶ Press  to open the next screen.



(2)Determining the code deletion position

- ▶ Using Jog , , determine the position to delete the code. (D point)
- ▶ Press  after determining the position.

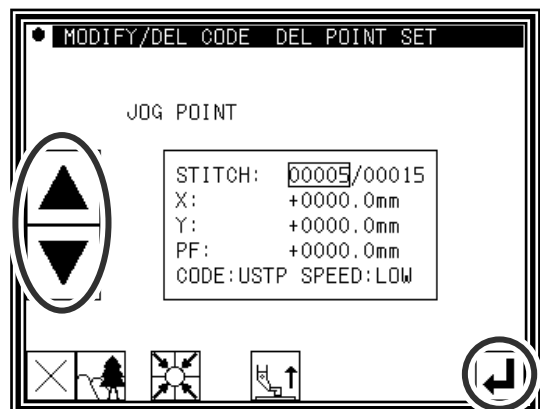

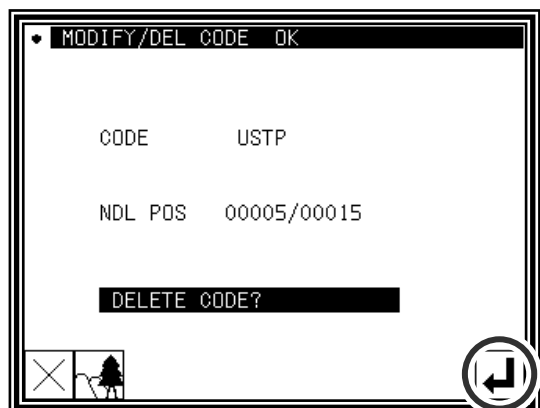

(3)Confirming execution

- ▶ Press .
(The code data will be deleted.)







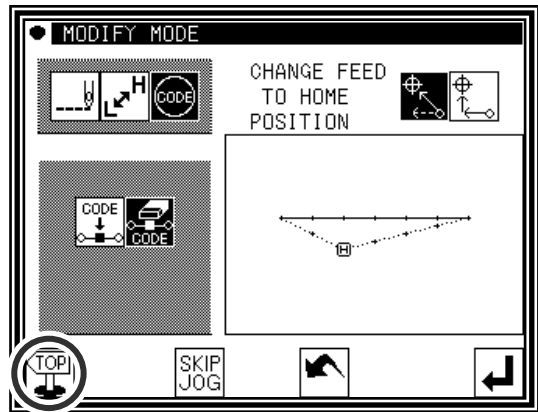















(4) Confirming the modifications

- Quit the modification mode. Press  to change to the Saving mode screen. Press  to return to the Standard screen after saving the data. (When  is pressed, the modifications executed last will be undone.)





[12] Data conversion mode

1. Main data conversion mode functions

| Function | icon | Details | Details setting | |
|---------------------------------------|---|--|---|--|
| Back tacking ([12]-3) |  | Existing back tacking can be modified, and new back tacking can be created. |   | Start/end back tacking Overlap back tacking (Valid only for a closed figure.) |
| Zigzag stitching ([12]-7) |  | Existing zigzag stitching can be modified, and new zigzag stitching can be created. | - | |
| Scaling ([12]-9) |  | Scaling with a set stitch length or set No. of stitches can be carried out independently for the X axis and Y axis centering on the center point. | <Center position>  Jog Designation  Pattern Center  Home position Center |  No. of Stitches Fixed  Fixed Stitch Length |
| Symmetrical ([12]-12) |  | Using the existing sewing data, X-axis, Y-axis, or XY axis symmetrical pattern can be created. Whether to keep or delete the existing stitching data can also be selected. | <Methods>  Symmetrical Origin Clear  Keep Symmetrical Origin | |
| Rotation ([12]-13) |  | The pattern can be rotated centering on a random center point. | <Center Position>  Jog Designation  Pattern Center  Home position Center | |
| Offset ([12]-15) |  | The offset distance and direction for offset stitching data can be changed. | - | |
| Multiple ([12]-18) |  | The multiple distance, multiple direction and number of multiple stitching times for multiple stitching data can be changed. | - | |
| Home position correction ([12]-20) |  | The mechanical home position can be moved in 0.1mm increments. | - | |

2. Entering the conversion mode

► Press  and  on the Standard screen to enter the conversion mode.

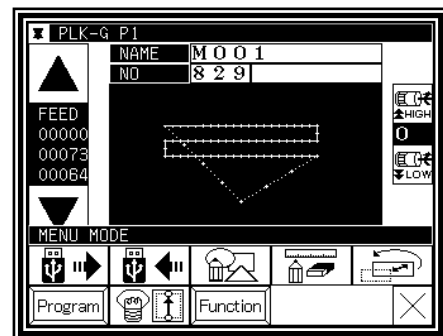

3. Quitting the conversion mode

► After converting the data, press  to quit the conversion mode.

(When  is pressed, the conversions executed last will be undone.)

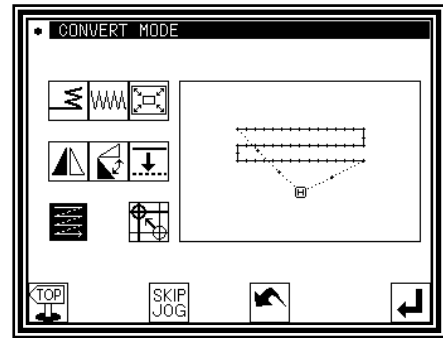

4. Confirming on the image screen (for the conversion mode)

(Refer to the section "Confirming on the image screen " for the modification mode for explanations common for the modification mode and conversion mode.) Page[11]-3

■ Scaling, rotation

 : Indicates the home position.
(Common for all Image screens.)

 : Indicates the center position.

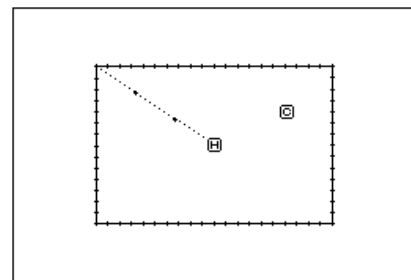

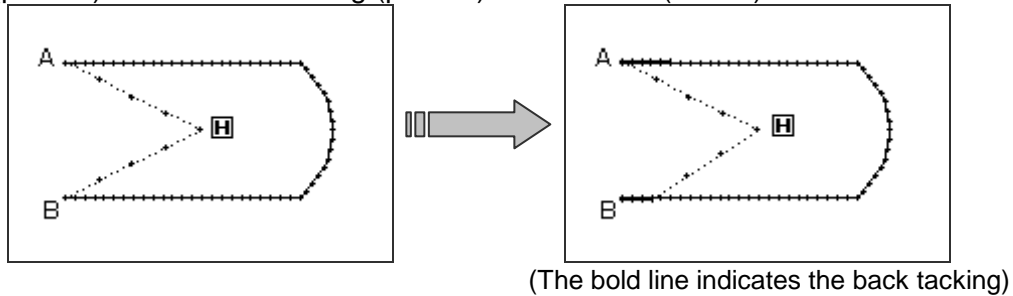

5.Back tacking(Start/end back tacking)

[Example] In the following type of stitching data, the start/end back tacking at the start of stitching (point A) and end of stitching (point B) is converted (added).



Operation details

(1)Selecting back tacking

- ▶ Enter the conversion mode.
- ▶ Press Back tacking .
- ▶ Press .

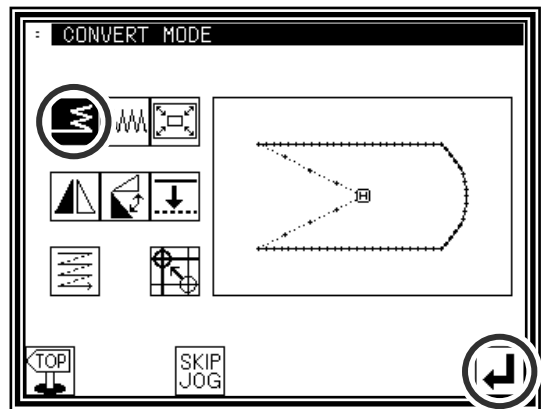

(2)Setting the block for converting back tacking

- ▶ Using jogging, move to the block where back tacking is to be converted. (In this case, move to a point between point A and point B.)
- ▶ Press .

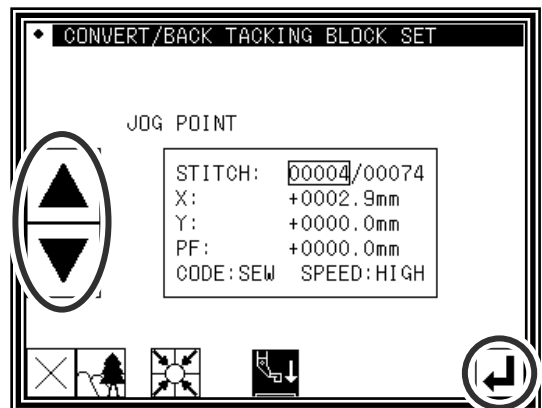

(3)Selecting start/end back tacking

- ▶ Press start/end back tacking .

Memo If the selected block is a "closed figure", the overlap back tacking icon will also appear. (Selection will be enabled.) This is not displayed in this example. (Selection is not possible.)

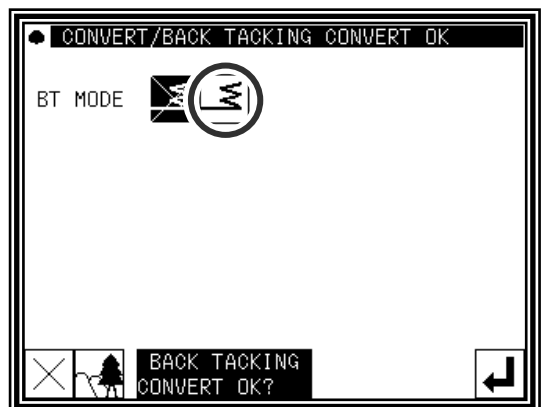



(4) Setting the back tacking details

- ▶ The details are set on this screen.

(The details set here are,

 (start/end back tacking)),

start mode  (N mode), five start stitches,

end mode  (M mode), three end stitches.)

- ▶ Press .

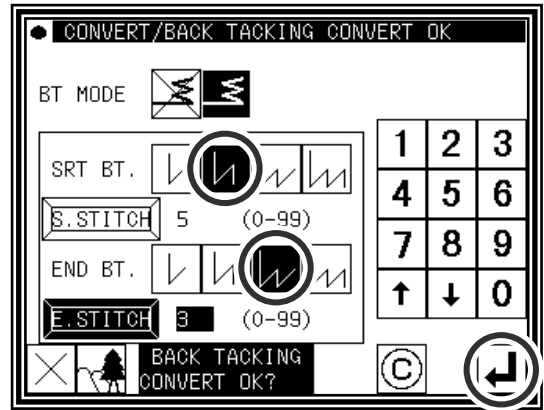

(5) Confirming execution of conversion

- ▶ Quit the conversion mode. Press  to change to

the Saving mode screen. Press  to return to the Standard screen after saving the data.

(When  is pressed, the conversion executed last will be undone.)

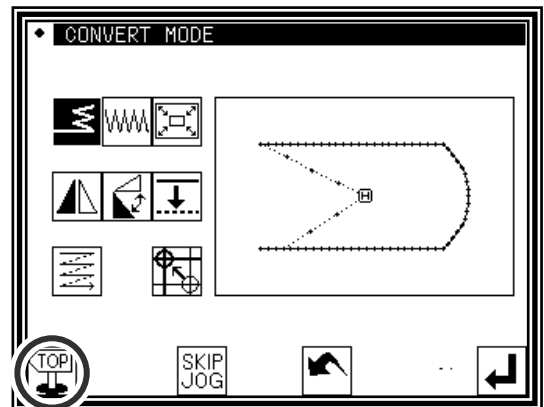

6.Back tacking(Overlap back tacking)

[Example] In the following type of stitching data, the overlap back tacking is converted
(point A-B-C-D-A : Broken line)

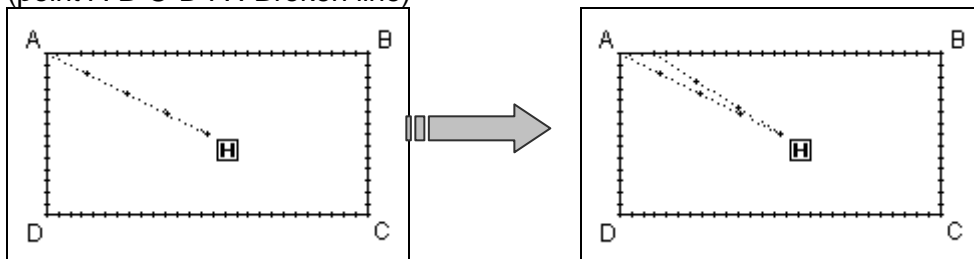

Operation details

(1)Selecting back tacking

▶ Enter the conversion mode.

▶ Press Back tacking

▶ Press

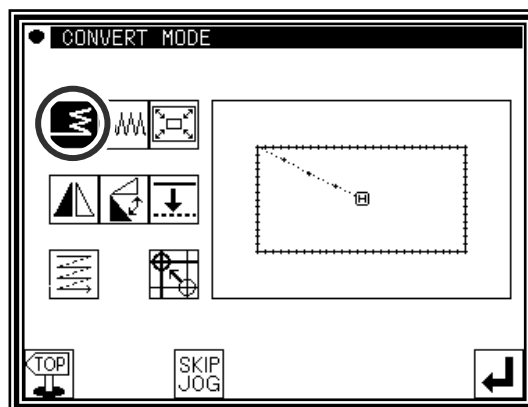

(2)Setting the block for converting back tacking

▶ Using jogging, move to the block where back tacking is to be converted.

▶ Press

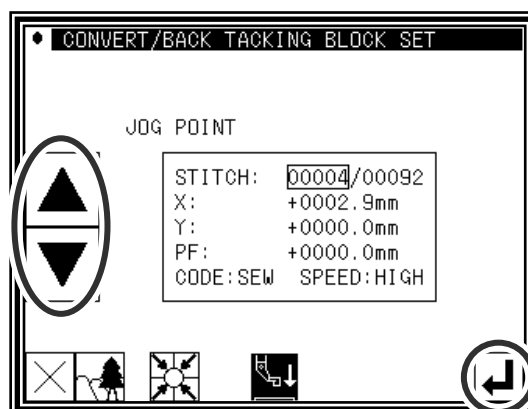

(3)Selecting overlap back tacking

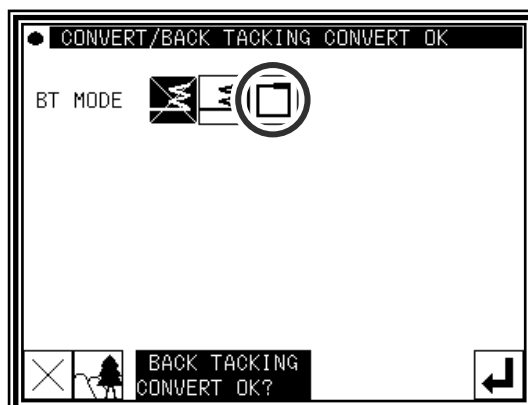

▶ Press overlap back tacking

Memo If the selected block is a "closed figure", the overlap back tacking icon will also appear. (Selection will be enabled.) This is displayed in this example. (Selection is possible.)



(4) Setting the back tacking details

- ▶ The details are set on this screen.
(The details set here are,



 (overlap back tacking), overlap mode ,

three overlap stitches.)

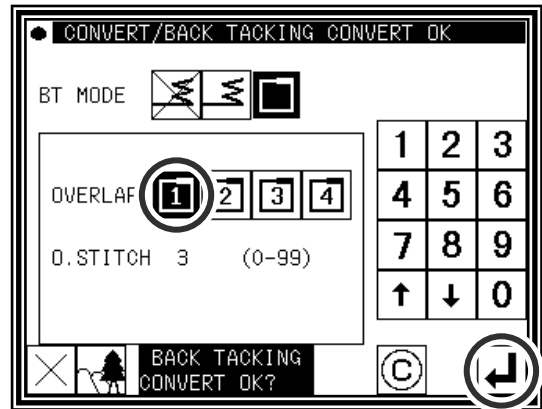
- ▶ Press .



(5) Confirming execution of conversion

- ▶ Quit the conversion mode. Press  to change to the Saving mode screen. Press  to return to the Standard screen after saving the data.

(When  is pressed, the conversion executed last will be undone.)

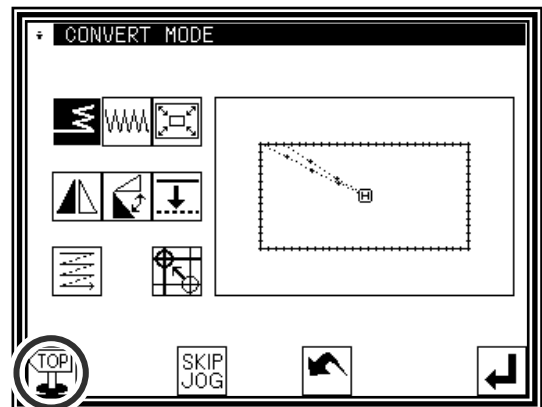

7.Zigzag stitching

[Example] In the following type of stitching data, the arc section between point B and point C is converted (added) to zigzag stitching. (Point A to point B: linear, point B to point C: arc, point C to point D: linear)

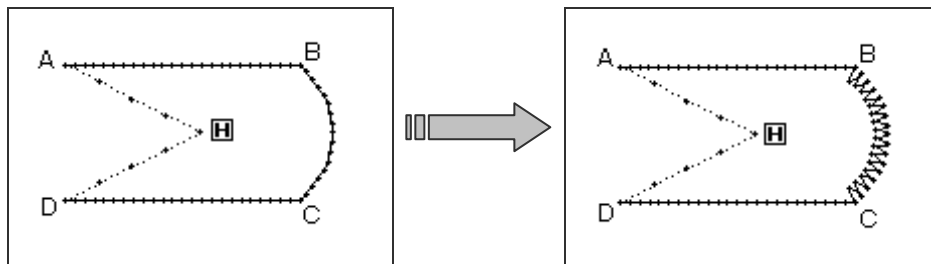

Operation details

(1)Selecting zigzag stitching

▶ Enter the conversion mode.

▶ Press zigzag .

▶ Press .

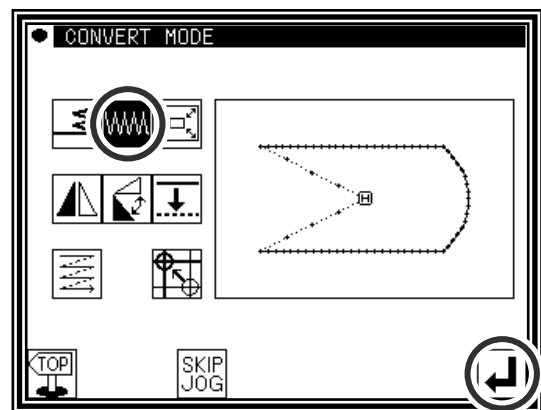

(2)Setting the block for converting zigzag

▶ Using jogging, move to the block to be converted to zigzag stitching. (In this case, move to the arc section (point between point B and point C).)

▶ Press .

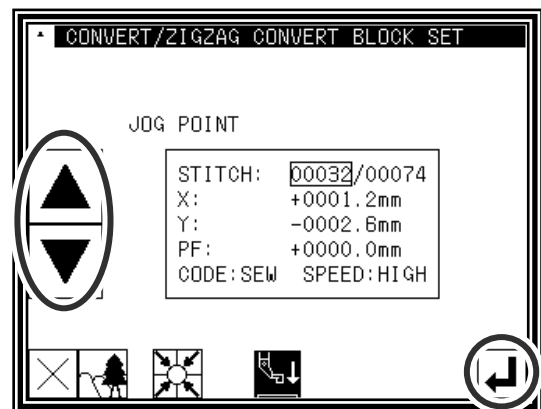

Memo The block range can be confirmed easily when the Image screen is opened from the (2) screen.

▶ Press  from the (2) screen.

▶ Press  to return.

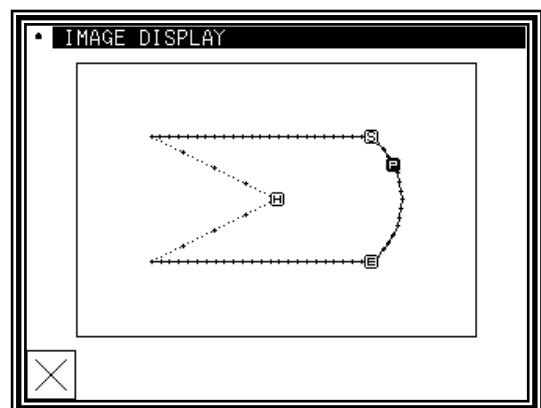

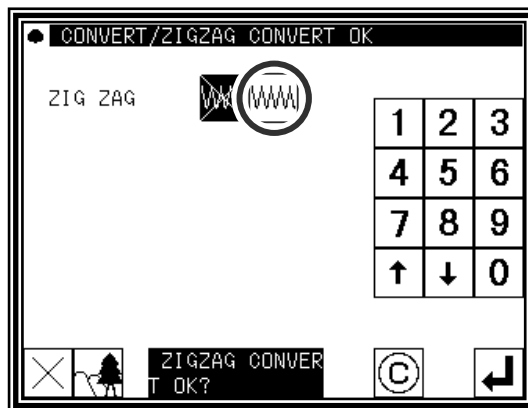

(3) Selecting zigzag

▶ Press zigzag .



(4) Setting the zigzag details

▶ The details are set on this screen.
 (Press , set the deflection width to 5.0, and feed amount to 3.0.)



The creation direction is .

(Refer to section [7] Methods of creating sewing data (12) Zigzag stitching for details on the "deflection width, feed amount and creation direction".)

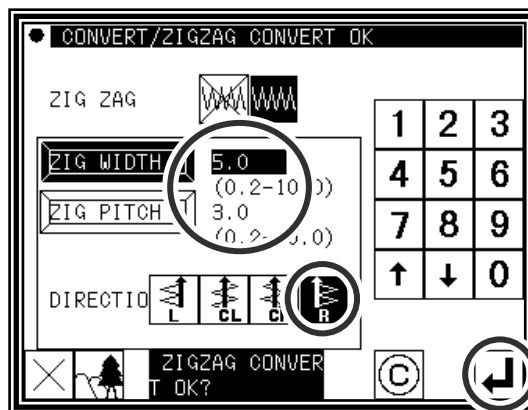
▶ Press .



(5) Confirming the converted data

▶ Quit the conversion mode. Press  to change to the Saving mode screen. Press  to return to the Standard screen after saving the data.
 (When  is pressed, the conversion executed last will be undone.)

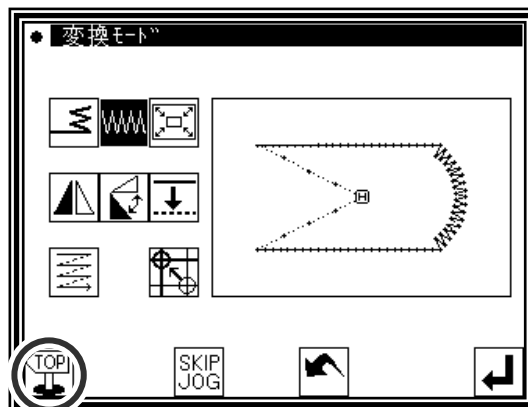

8. Scaling

[Example] The data will be reduced (X: 50%, 75%) with a fixed stitch length centering on the A' point in the following type of stitching data.

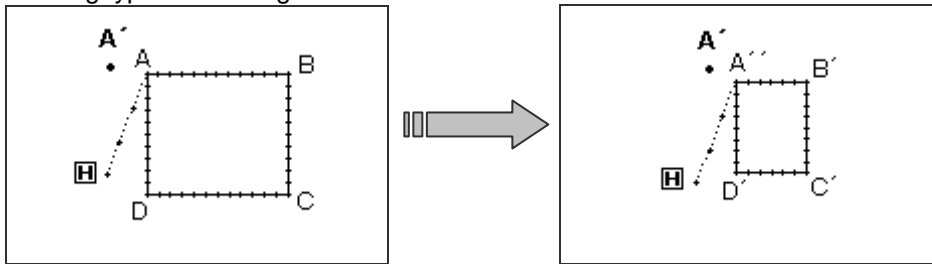

Operation details

(1) Selecting scaling

▶ Enter the conversion mode.

▶ Press Scaling

▶ Press

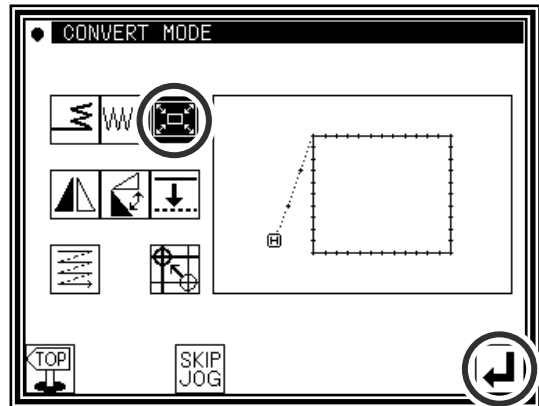

(2) Setting the scaling method, etc.

▶ Method

: No. of Stitches Fixed

: Fixed Stitch Length

(Press Fixed Stitch Length for this example.)

▶ Set the X, Y enlargement rate (reduction rate) with the numeric keypad or up/down arrow icons.

▶ Center designation

: Jog center designation, : Pattern center,

: Home position center

(Press Jog Center Designation for this example.)

▶ Press

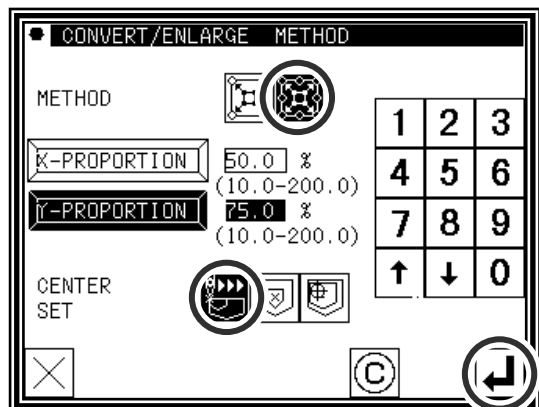

(3) Setting the center position

▶ In the jog mode, move to the needle near the desired enlargement/contraction center. (In this case, move to point A that is near point A'.)

▶ Press

Memo The center point can be designated without using the jog icons.

In this case, press only .

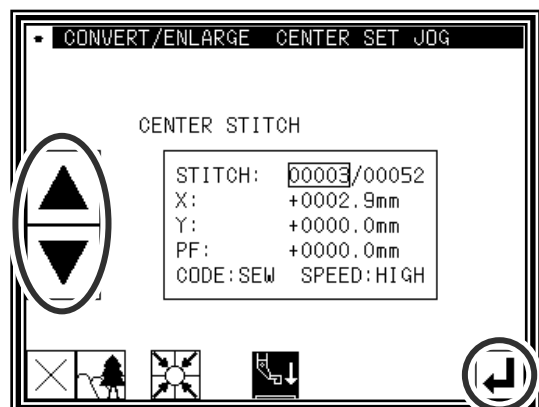

(4) Setting the center position details

▶ If the center point is not to be set on the stitching data, use the arrow icons and move to the position to be used as the center. (A' point)

▶ After moving to the desired center position,

press .

Memo If the desired center position is on the pattern data, do not move using the arrow,

but just press .

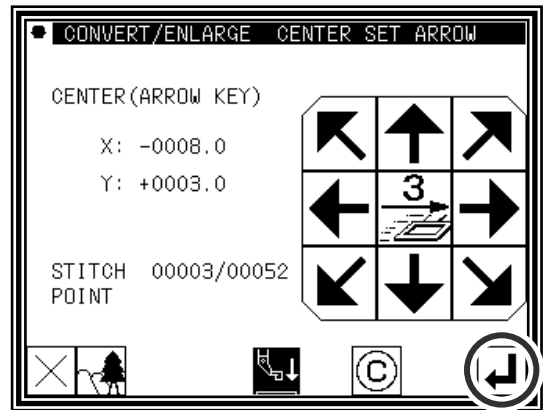

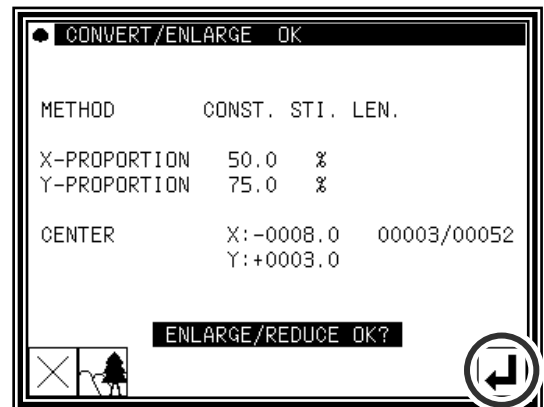

(5) Confirming execution of conversion

▶ Press .



(6) Confirming the converted data

▶ Quit the conversion mode. Press  to change to the Saving mode screen. Press  to return to the Standard screen after saving the data. (When  is pressed, the conversion executed last will be undone.)

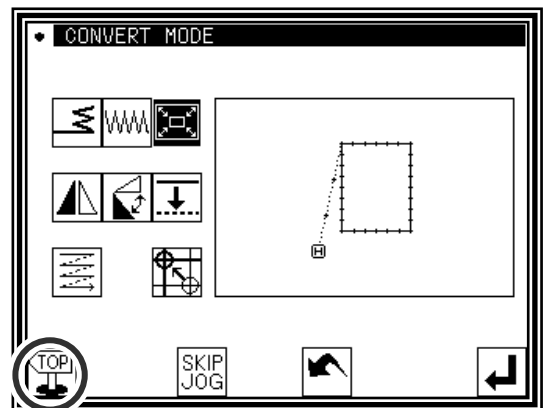

Memo 1 Circle scaling

A circle will be created even if the X, Y enlargement ratio/contraction ratio are set to different values.

Memo 2 Expanded/reduces for zigzag sewing, multiple sewing, and offset sewing.

Sewing in zigzag, multiple, and offset an under mentioned set item is not influenced by the expansion/the reduction.

(The function as the offset is lost by the expansion/the reduction about the offset.)

- "Amount of stitch length" and "Width of shake" of zigzag sewing
- "Distance" of multiple sewing
- "Distance" of offset

(Do not use expansion/reduction but respectively to change these zigzag sewing, multiple sewing, offset sewing in the conversion mode if modify to do.

[Example] It is expanded like 3mm of B in the offset width, when data [A] of multiple sewing of the 3mm width and expands 200% of X scale made by B data like the figure below.

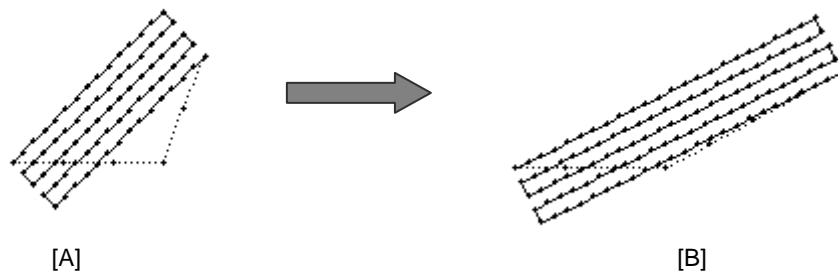

Memo 3 "Fixed stitch number/stitch length fixed" setting for expanded/reduces for zigzag sewing

"Stitch number fixed/stitch length fixed" setting of the expansion/the reduction is not influenced by zigzag sewing. (Please reference to Page [12]-7 Conversion mode of zigzag sewing or Page [11]-32 block correction to do.)

9.Symmetrical

[Example] The left state of the following type of stitching data will be converted into a right state.

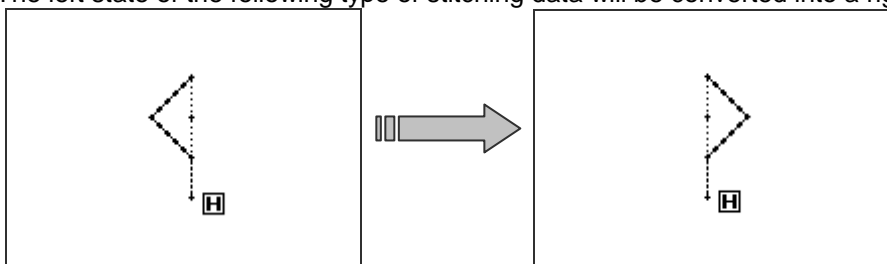

Operation details

(1)Selecting symmetrical

▶ Enter the conversion mode.

▶ Press Symmetrical

▶ Press

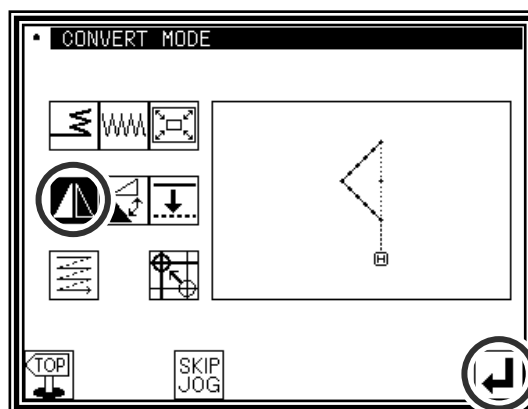

(2)Setting symmetrical method, etc., and executing

▶ Clearing symmetrical origin data

:Delete Symmetrical Origin Data

:Keep Symmetrical Origin Data

(Press "Delete" for this example.)

Memo When 「Keep symmetrical original data」 is selected, [material stel level] setting is not reflected to symmetrical data.

▶ Method

:X Symmetrical Data Creation

:Y Symmetrical Data Creation

:XY Symmetrical Data Creation

(Press "X Symmetrical Data Creation" for this example.)

▶ Press

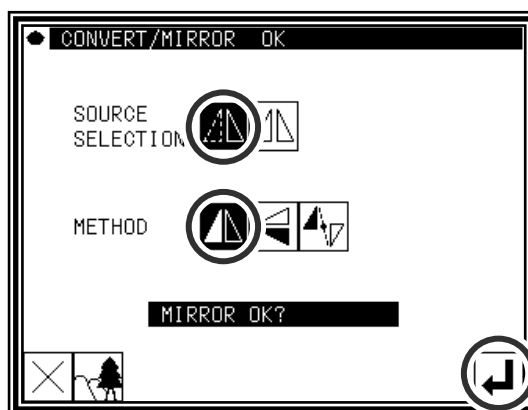

(3)Confirming execution of conversion

▶ Quit the conversion mode. Press to change to the Saving mode screen. Press to return to the Standard screen after saving the data.

(When is pressed, the conversion executed last will be undone.)

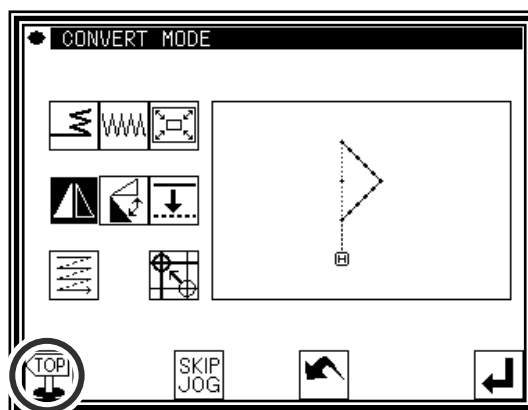

10. Rotation

[Example] The pattern will be rotated by 45° centering on the A point in the following type of stitching data.

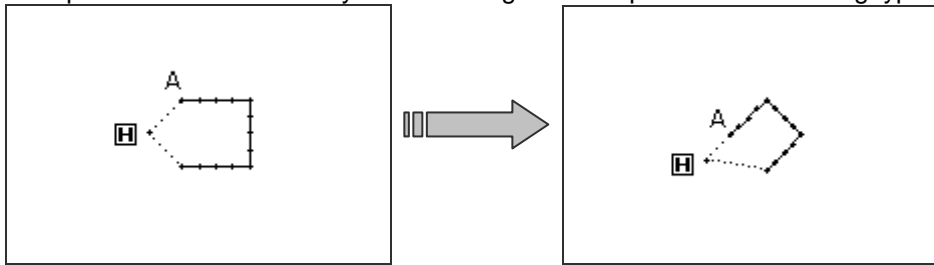

Operation details

(1) Selecting rotation

▶ Enter the conversion mode.

▶ Press Rotation

▶ Press

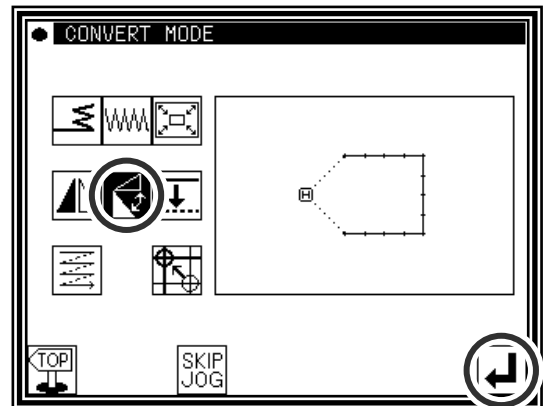

(2) Setting the rotation method, etc.

▶ Direction

: Left Rotation

: Right Rotation

(Press "Left Rotation" for this example.)

▶ Angle

Input the angle from the numeric keypad.
(Input 45\$ for this example.)

▶ Center Designation

: Jog center designation, : Pattern center,

: Home position center

(Press "Jog Center Designation" for this example.)

▶ Press

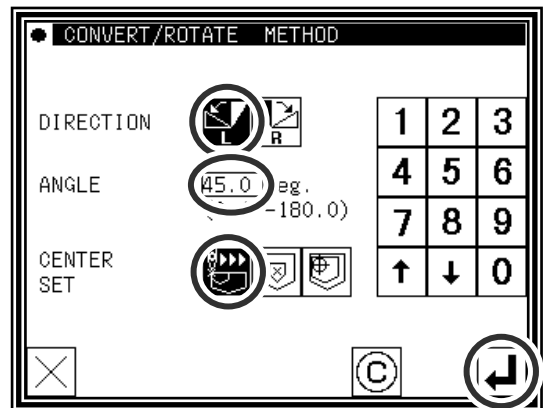

(3) Setting the center position

▶ In the jog mode, move to the needle near the desired center.

▶ Press

Memo The center point can be used without using the jog icons. In this case, press only .

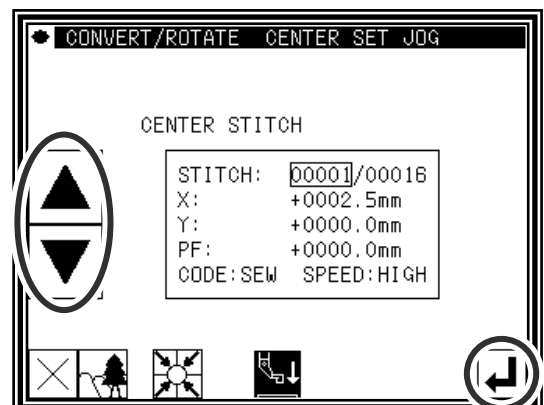

(4) Setting the center position details

▶ If the center point is not to be set on the stitching data, use the arrow icons and move to the position to be used as the center.

▶ After setting the center, press .

Memo If the desired center position is on the pattern data, do not move using the arrow, but just press .

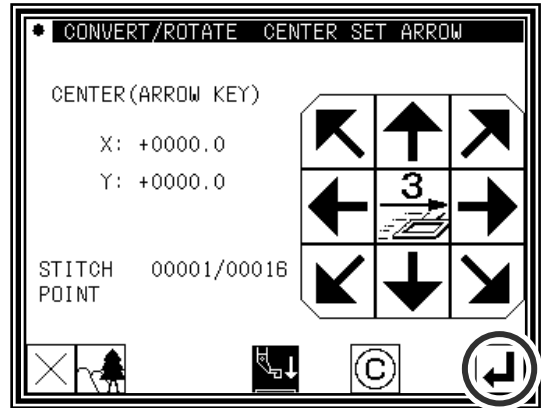

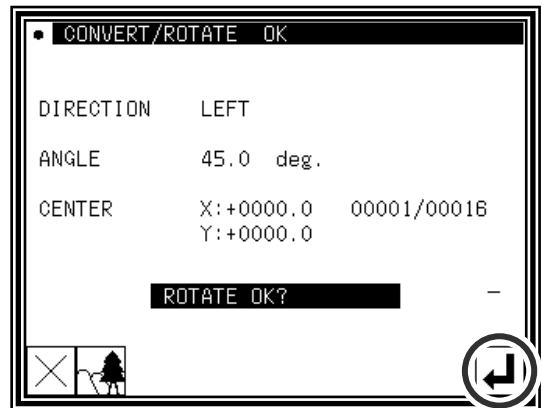

(5) Confirming execution of conversion

▶ Press .



(6) Confirming the converted data

▶ Quit the conversion mode. Press  to change to the Saving mode screen. Press  to return to the Standard screen after saving the data. (When  is pressed, the conversion executed last will be undone.)

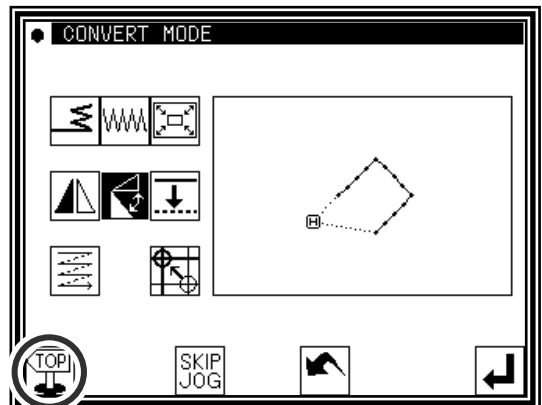

11.Offset

[Example] The offset distance for the offset stitches A-B and C-D in the following type of stitching data will be changed and converted into A'-B' and C'-D'. (The offset amount will be A-B: 5mm, C-D: 7mm, A'-B': 7mm, and C'-D': 9mm respectively.)

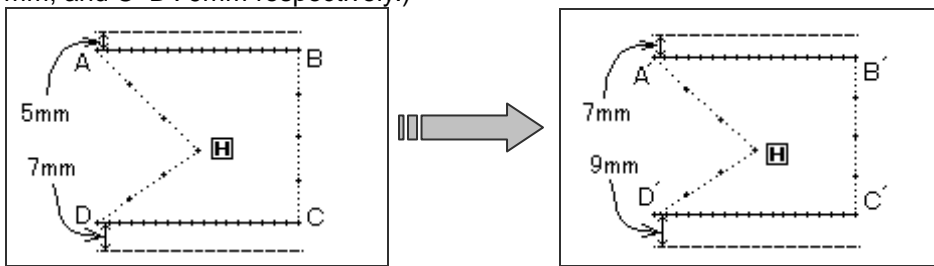

Operation details

(1) Selecting offset

▶ Enter the conversion mode.

▶ Press Offset

▶ Press

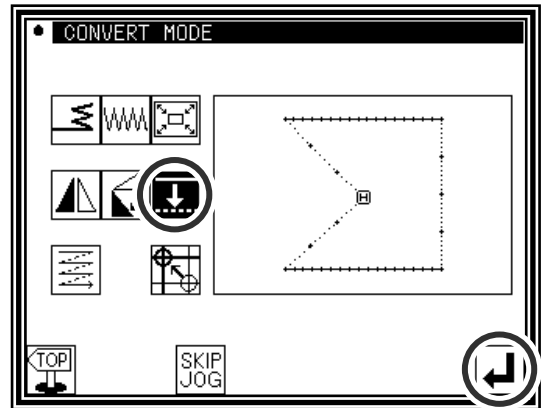

(2) Selecting and confirming the changed offset

▶ Press or to select the offset to be changed. (The offset numbers No. 1, 2, 3... are assigned in the created order.) (In this case, select the first offset data.)

▶ Press after select the data.

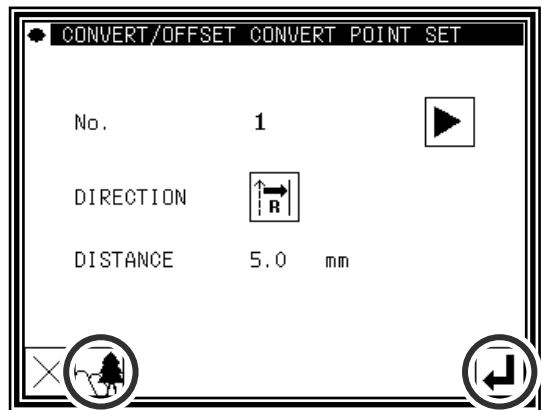

(3) Confirming the offset No. (Image screen)

▶ Press on the screen displayed in step 2.

▶ The offset No. will be expressed with **1** and **2**.

▶ Press

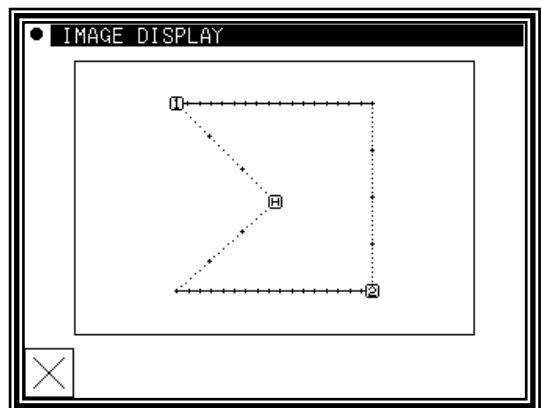

(4) Setting and executing the conversion method

- ▶ Select the direction. (In this case, select "right".)

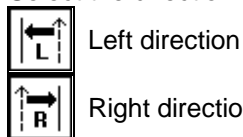

- ▶ Input the distance. (Input 7mm for this example.)

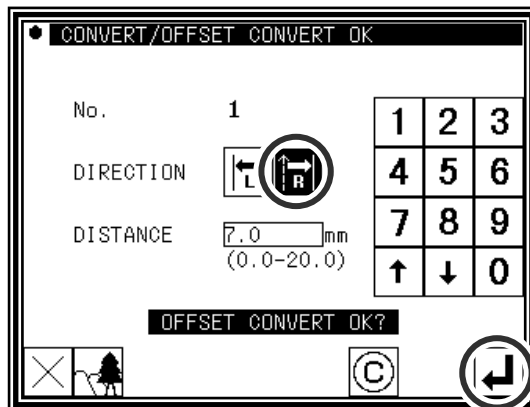
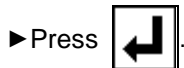

(5) Completing the first conversion

- ▶ Press to start the second conversion.

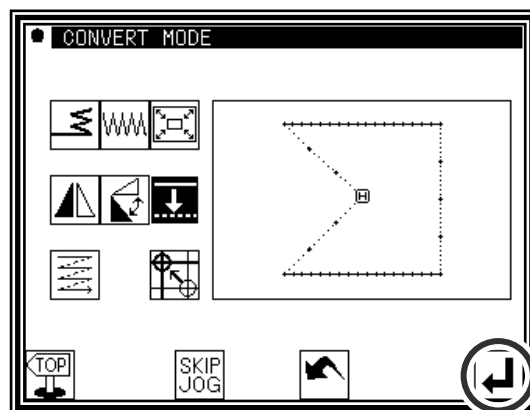

(6) Selecting and confirming the next offset.

- ▶ Using the arrow icons (), select the offset to be changed.

- ▶ Press after setting the data.

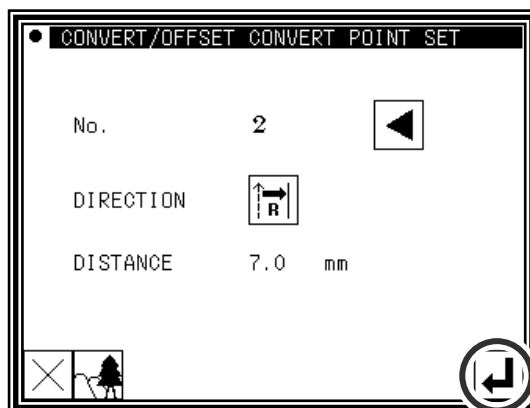

(7) Setting and executing the conversion method

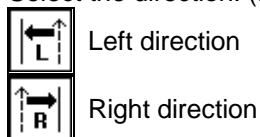

- ▶ Select the direction. (In this case, select "right".)

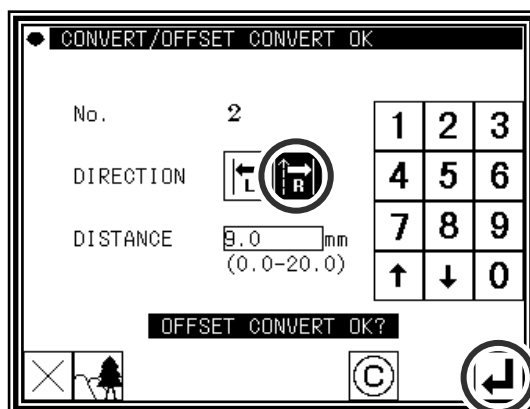
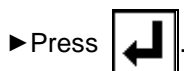

- ▶ Input the distance. (Input 9mm for this example.)



(8) Completing the second conversion

- Quit the conversion mode. Press  to change to the Saving mode screen. Press  to return to the Standard screen after saving the data. (When  is pressed, the conversion executed last will be undone.)

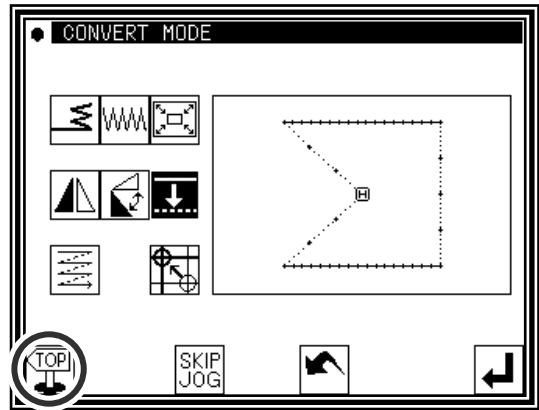

12. Multiple

[Example] ABCD designated two times for multiple stitching (feed data specifications) in the following type of stitching data, will be converted to the ABC'D'EF designated three times for reverse multiple stitching (feed data specifications).

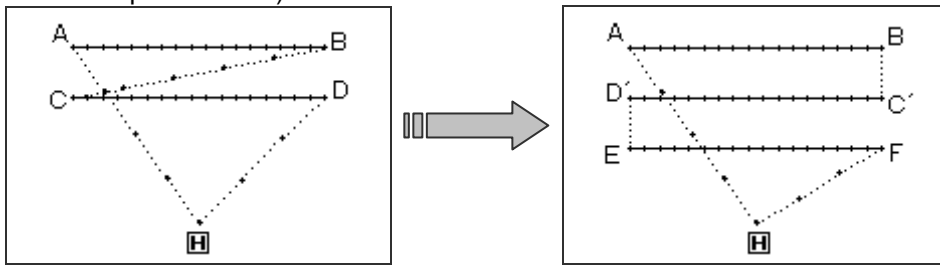

Operation details

(1) Selecting multiple stitching



▶ Enter the conversion mode.

▶ Press Multiple Stitching .

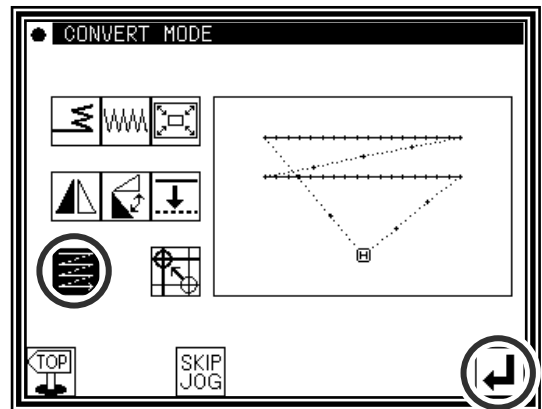
▶ Press .



(2) Selecting and confirming the multiple stitching to be changed

▶ If there are multiple settings, press the arrow icons ( ) (which appear when there are multiple settings), and change the setting.

▶ Press  after changing the setting.

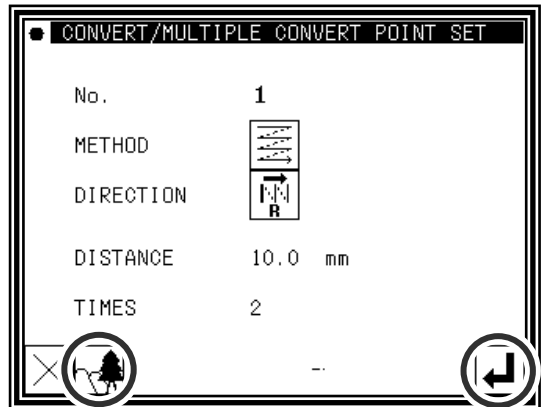

(3) Confirming on the image screen

▶ press  on the screen displayed in step 2.

▶ Confirm the multiple No., etc.

▶ Press  to return to the original screen.

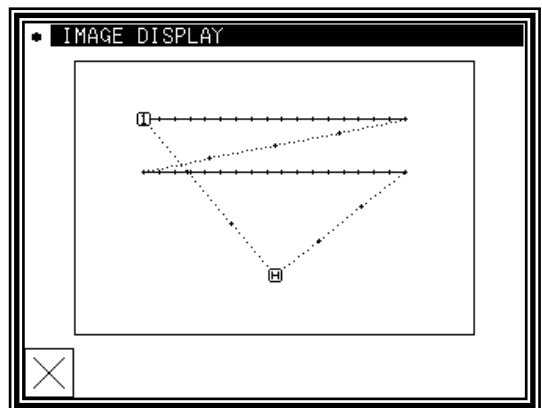

(4) Setting the conversion method

- ▶ Select and input the multiple stitching method, direction, distance and number of times.

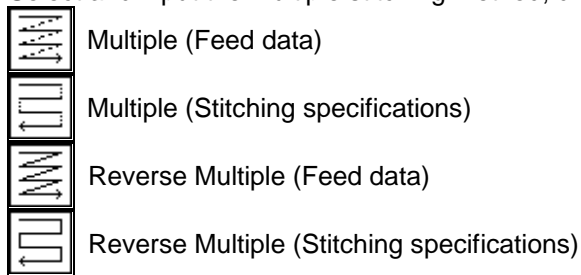

(In this case, select the "Multiple (Stitching specifications)")

- ▶ Select the direction. (In this case, select "right".)

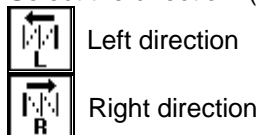

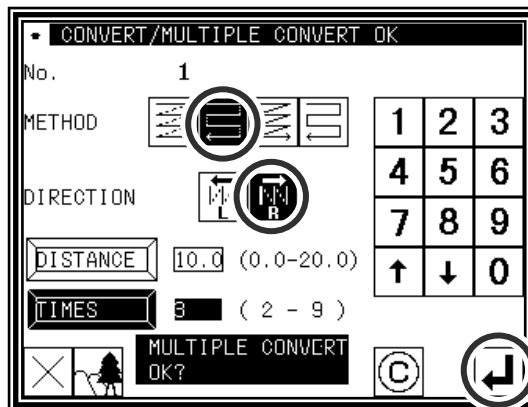

- ▶ Input the distance value. (In this case, input "10 mm".)
- ▶ Input the number of times. (In this case, input "3 times".)

- ▶ Press .



(6) Confirming execution of conversion

- ▶ Quit the conversion mode. Press  to change to the Saving mode screen. Press  to return to the Standard screen after saving the data. (When  is pressed, the conversion executed last will be undone.)

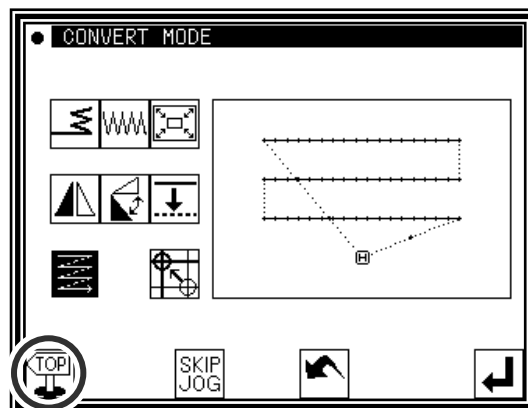



13.Home position correction

The mechanical home position can be moved in 0.1mm increments.
The movement amount must be within 12.7mm.

Operation details

(1) Selecting home position correction

- ▶ Enter the conversion mode.
- ▶ Press home position correction .
- ▶ Press .

Caution The work holder will move.
Take care when the needle is lowered, etc.

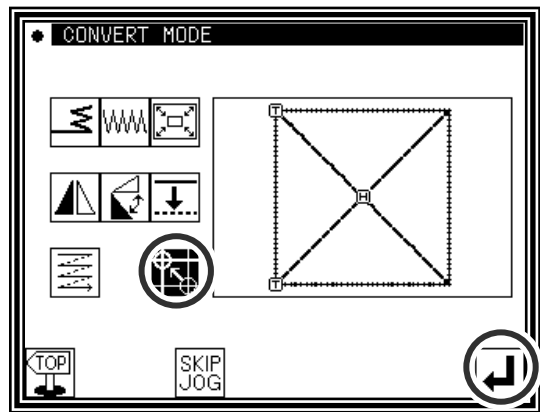

(2) Selecting correction valid

- ▶ Press home position correction valid .

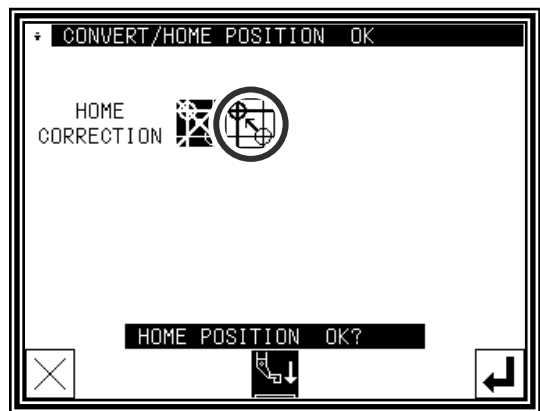
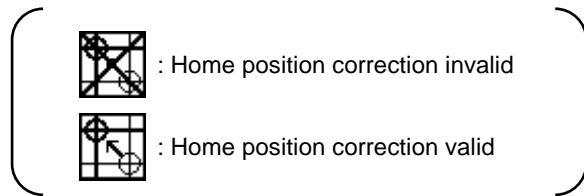

(3) Determining the position of home position correction

- ▶ The value of the correction is set by pressing arrow keys.
The range that can be corrected is ± 12.7 mm in both X and Y axes.

- ▶ Press .

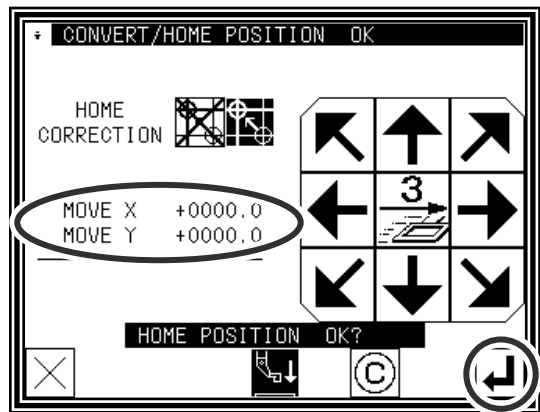

(4) Coming off the conversion mode

- ▶ Press .

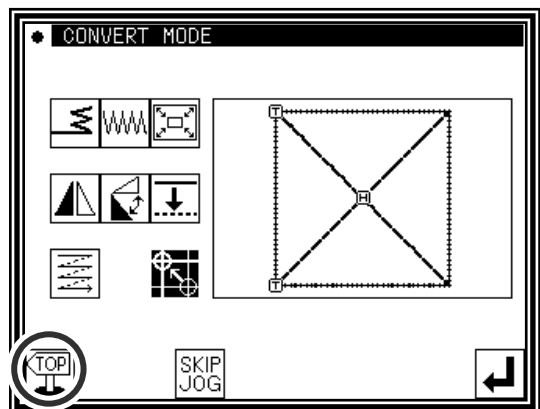

(5) Confirming the setting

▶ When home position correction valid, home position icon is

displayed in reverse video. 

* The value of home position correction saves to the control box. But this value doesn't save to the system setting file. This value can't be copied onto other control boxes.

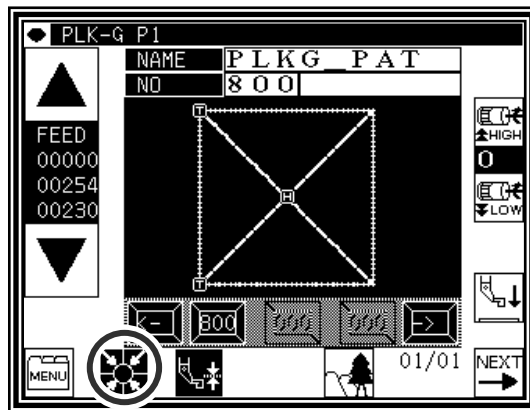

Memo1 Deleting home position correction setting

▶ Press home position correction invalid 

▶ Press 

Caution The work holder will move.
Take care when the needle is lowered, etc.

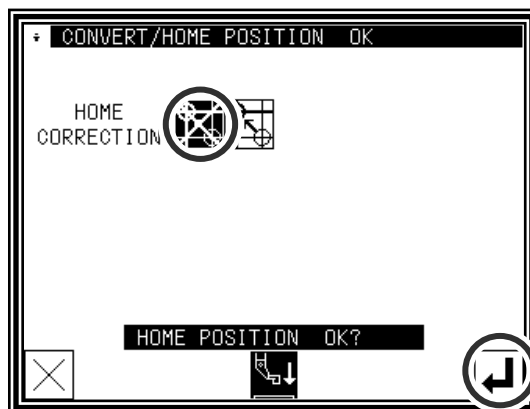

Memo 2 [M2H] function

When [M2H] in [Pattern] of program mode is set besides [OF], the home position correction is compulsorily released. (It is necessary to set [M2H] in [Pattern] of program mode to [OF] to set the home position correction.)

Memo 3 Home return

The home return moves to the corrected home position through the sensor home position once when the power supply is turned on.

Moreover, tracks of the home return are different according to the combination of the setting of [SHP] ([Home position] group of program mode) and [FKT] ([Feed method] group of program mode).

Please make the frame in consideration of tracks of the home return.

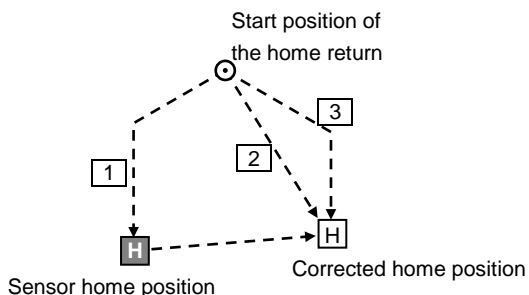

- 1 It returns to the corrected home position through the sensor home position.
- 2 It returns to the corrected home position in the direction of diagonal.
- 3 It returns to the corrected home position in the direction of 45 degree.

| | | [SHP] | | |
|-------|----|------------------------|----|---|
| | | ON | OF | |
| [FKT] | ON | First time | 1 | 1 |
| | | Since the second times | 1 | 2 |
| | OF | First time | 1 | 1 |
| | | Since the second times | 1 | 3 |

Memo 4 Area limit

The area size that can be used narrows when the home position is corrected. Please change the area size by the area limit so as not to knock against the frame.

*[XL],[XR],[YU],[YD] are provided in [Area limit] of the program mode.

Setting example

Area size : 300mm x 200mm

Correction value : X : +10mm, Y : -10mm

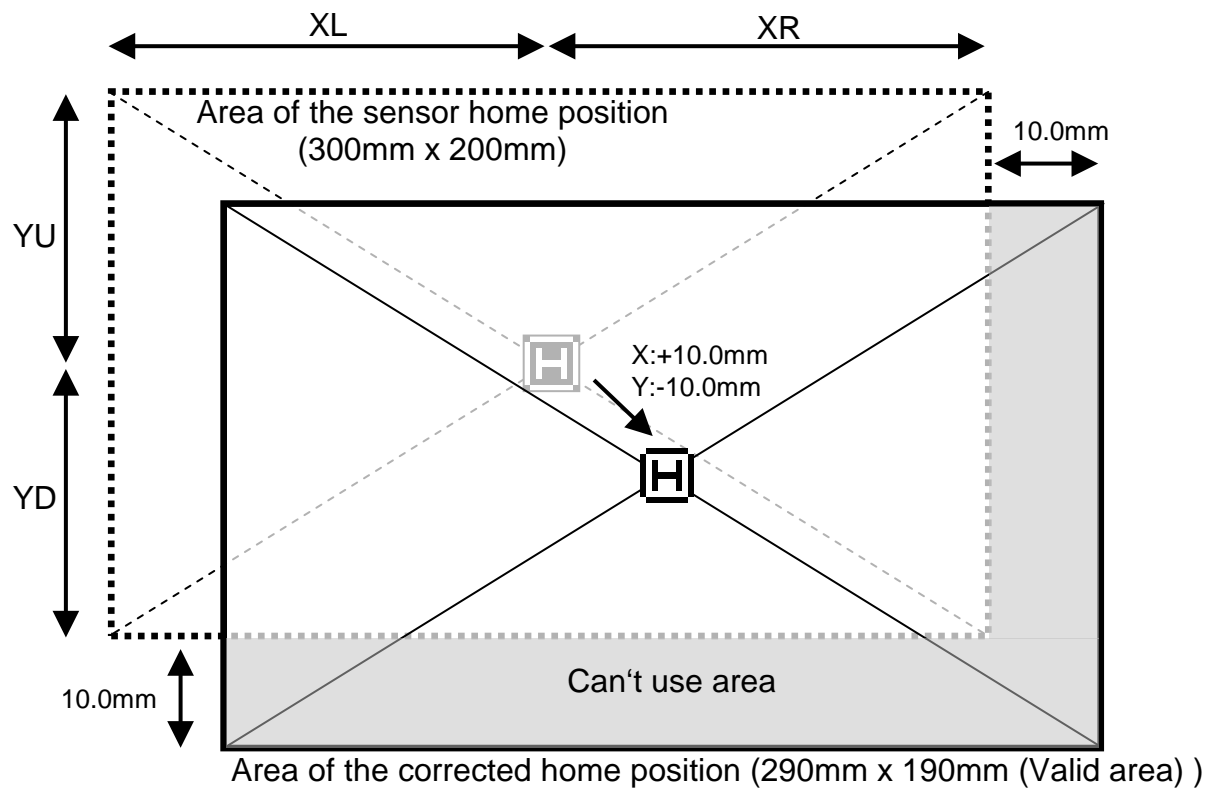

Setting change of area limit

| | Default value | | Change value |
|------|---------------|---|--------------|
| [XL] | 1500 | → | 1500 |
| [XR] | 1500 | → | 1400 |
| [YU] | 1000 | → | 1000 |
| [YD] | 1000 | → | 900 |

[13] Function mode

1.Outline

■List of function modes

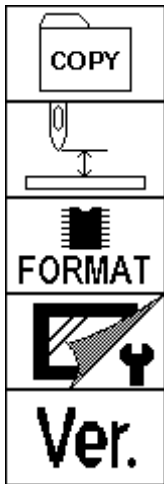

Copy mode

Needle down angle setting

Format mode

Screen customize

Version confirmation



Panel related settings

Set file read

System, set file write

Advanced functions

Combination mode

■Entering the function mode

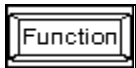
► Press  and  on the Standard screen, and open the Function Mode screen.

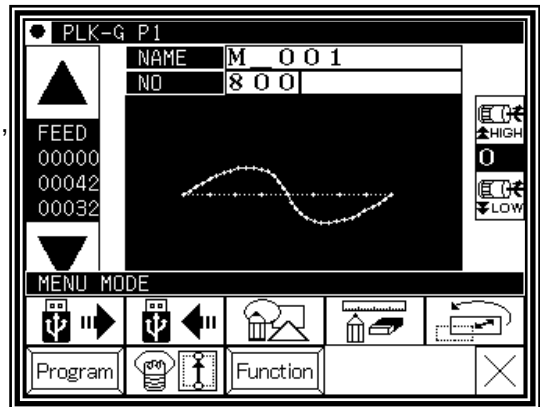

■Function Mode screen

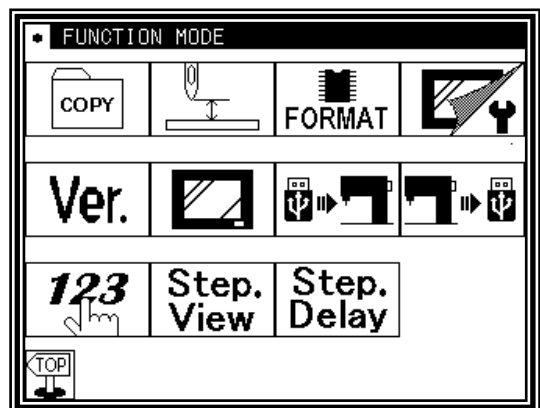

2.Explanation of each function mode



Copy mode

The sewing data is copied "from the internal memory to an USB memory" or "from an USB memory to the internal memory".

[Memo] Please erase all data of the USB memory beforehand when copying sewing data from an internal memory.

[Memo] Sewing data will be copied in the overwriting mode. For this reason, if the sewing data having the same data number is in the internal memory, the new sewing data will be overwritten on the old sewing data.

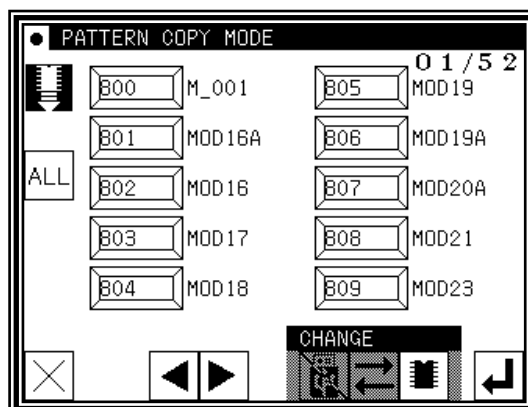



Select the copying direction in the same way as the data reading/writing operation. (Check the picture of the icon shown at the upper left section of the screen.)



From internal memory to USB memory



From USB memory to internal memory

Select the data you would like to copy by pressing the corresponding numeric icon (maximum 30). After that, press  to copy the data. (To select all the data, press .)

[Memo] Amount of datas which can be stored in the usb memory will be limited by capacity of the usb memory and also format type specification of the usb memory. Therefore, there is some cases, where data can not be saved even if there is enough empty space. Please check the manual of the usb memory.

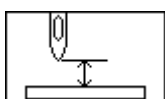

Needle DOWN angle setting

Before setting (to move to this screen), machine should be run once, and move needle to up position by pressing



icon.

The needle position angle for the needle UP/DOWN icon is set here.

U8 setting: Needle UP position stop setting



D8 setting: Needle DOWN position stop setting

R8 setting: Reverse run angle setting

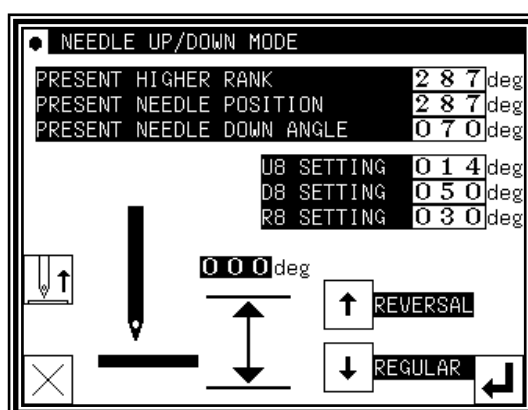
[Memo] Refer to Program mode [Needle Position] for details on these settings. (Page [16]-5)



Caution Be careful!

Pressing the icon ( ) will lift or lower the needle.



Format mode



Formats the internal memory.

All the pattern datas are cleared.

If the message like [Internal memory is defect] is appeared, please press this button.

Please back up data always so as not to lose data.



Optimizes the internal memory.

The pattern datas are not erased.

When preserved sewing pattern data increased and an empty space of an internal memory decreases, empty space might be able to be increased by executing optimization. (It is recommended to backup and perform optimization sometimes)



Clears the registration of the shortcut icon displayed on a standard screen.

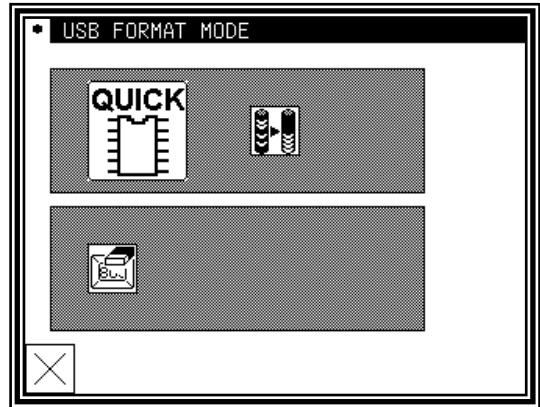

Screen customize

The icon arrangement on the screen can be customized to the simplified screen.

(Please consult the sewing machine agent about details of the screen customize. Here explains the setting of "Simple 1 and 2" screen and "Edit of Short cut".)

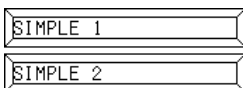

Two kinds of simple screens are prepared like as bellows.

Press [Simple 1] or [Simple 2] icon five or more seconds to change the screen.

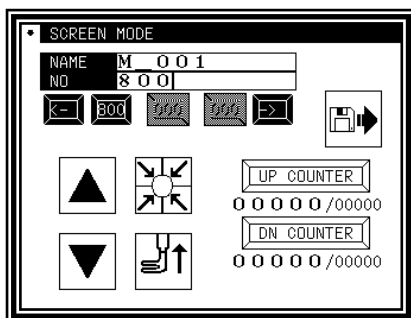
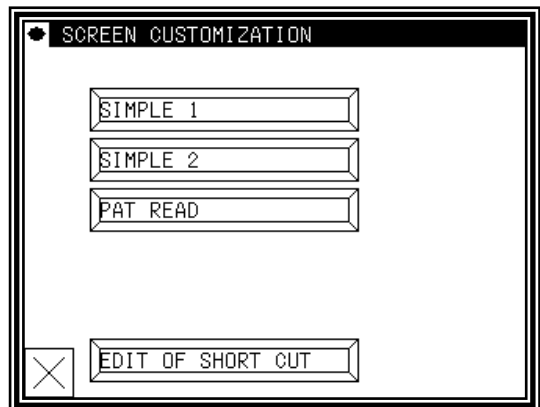

[Simple 1]

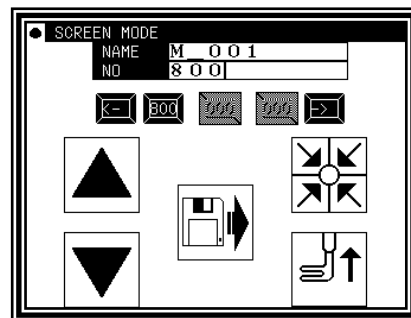

[Simple 2]

▶ To return to the standard screen, press title bar on the top of the screen five or more seconds.

▶ Press , to return to function mode screen.

EDIT OF SHORT CUT

"Short cut" icon of the sewing data is displayed on a standard screen. This icon is displayed in reading order usually. This order of the row can be freely permuted in the "EDIT OF SHORT CUT" function. The example of the operation method is shown below.

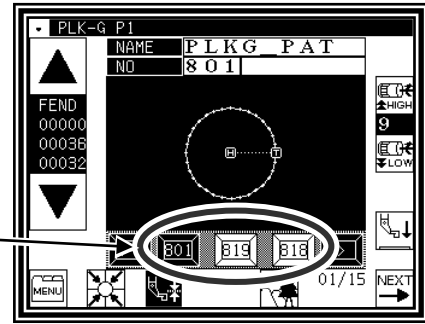

(1) Press the numeric key on "EDIT OF SHORT CUT" screen. ("8" in this example)

The data saved in an internal memory is displayed on the selection candidate group. (It is displayed from 800 to 809 in this example.)

(2) Selects the number that wants to be arranged to the short cut from the selection candidate group.

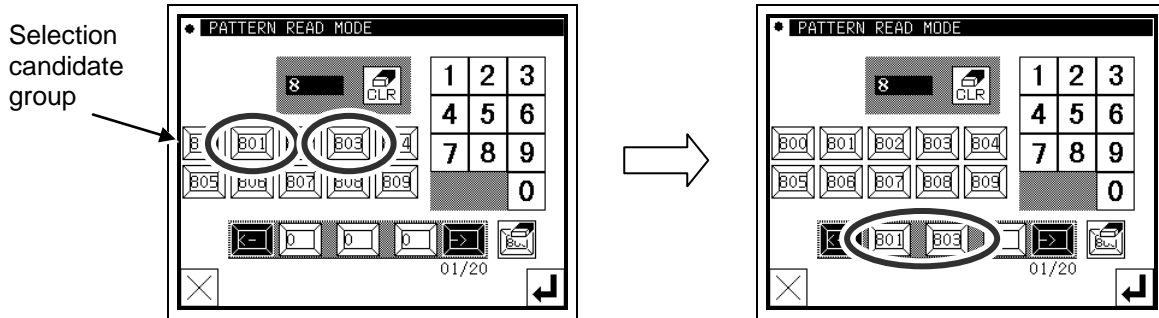

(3) After  pressed when the selection candidate group is changed, press the numeric key. ("9" in this example)

(4) Selects the number that wants to be arranged to the short cut from the selection candidate group. (Short cuts can be selected up to 20.)

When the selection is completed, press .

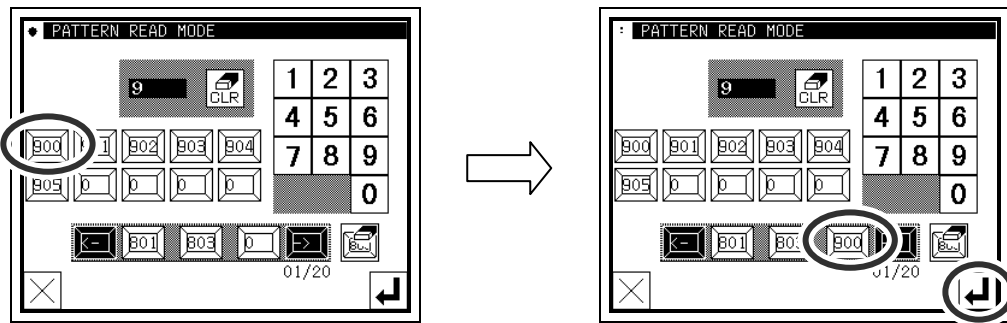

► The selection can be released by pressing the number that arranged in the short cut.

To release all the numbers arranged in the short cut, press .

(The number cannot be inserted on the way of the short cut.)

(5) The short cut has been changed when returning to a standard screen.

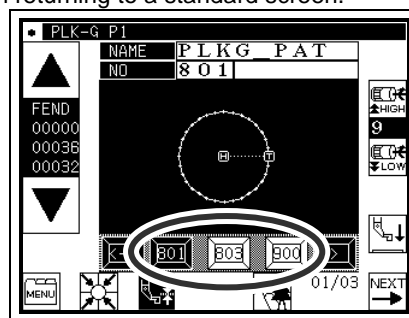



Version confirmation

The version of each model's current system can be confirmed.

(The version shown on the right is an example.)

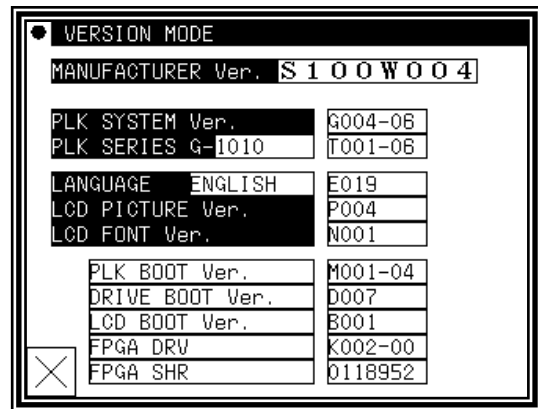

Panel related settings

Various settings related to the panel can be made.

[Wallpaper Color Selection]

The wallpaper color (black/white) is reversed. Select the wallpaper that is easy to view.

[LCD Backlight Auto OFF]

The panel will automatically turn OFF if the panel is not touched within the set time.

Setting range : 1 to 9 minutes

Canceling method : Touch the panel which is turned OFF.

(The automatic OFF function will remain "Valid" until the LCD backlight automatic OFF function is set to "Invalid".)

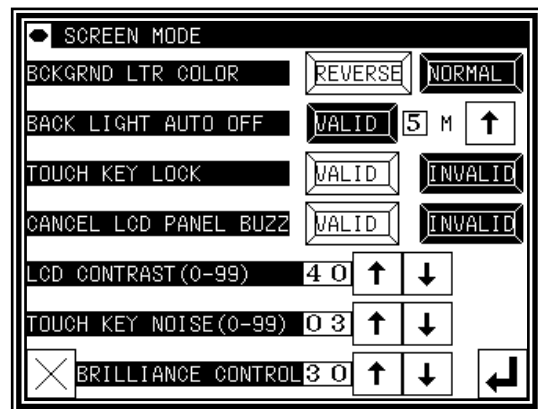

[Touch Key Lock]

When this function is set to "Valid", the icons will be ignored even if pressed, and the incorrect operation prevention mode will be entered.

Canceling method: To cancel the incorrect operation prevention mode, press any place on the panel for five or more seconds. A beep will sound to indicate that the function has been canceled. (The touch key lock will be completely set to "Invalid" with this cancellation.)

[Cancel LCD panel buzzer]

When it is set to enable, sounds will not ring.

[LCD Contrast]

Set the panel contrast.

Setting range: 0 to 99 (The screen will dim as the value is increased.)

[Key Noise Processing]

The noise will increase as this value is increased. The icon response speed will also drop. (The opposite will occur when the value is decreased.)

Setting range: 0 to 10

[Brilliance control]

Sets brightness of the operation panel.

Setting range: 0 to 50



Setting file read

Setting files or step files written (backed up) on a USB memory are read out.

[Memo] The data is read in the overwrite mode, so the setting file originally in the internal memory will be erased.

- [*.DSG] ---The Simple setting table
- [*.DSK] ---The multiplication data
- [*.PGS] ---The step file

For detail operation, refer P.[15]-5.

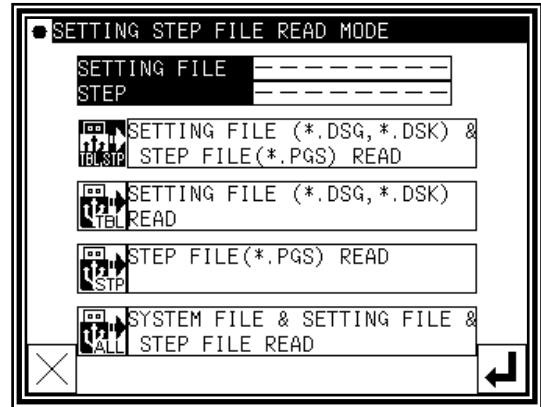

System, setting file write

The system setting files and step files are written (backed up) on a USB memory.

If various files are stored, be careful not to overwrite new data on a file.

For detail operation, refer P.[15]-4.

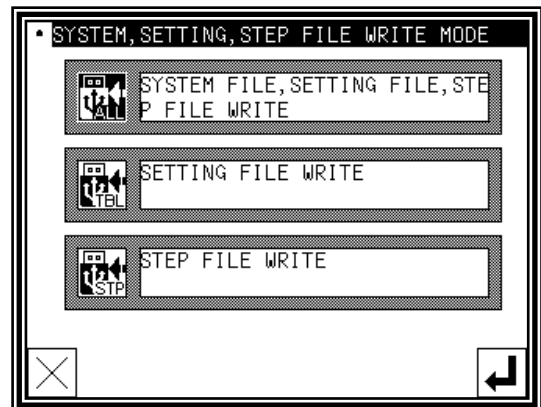

Advanced functions

"Advanced functions" can be set by inputting a password.

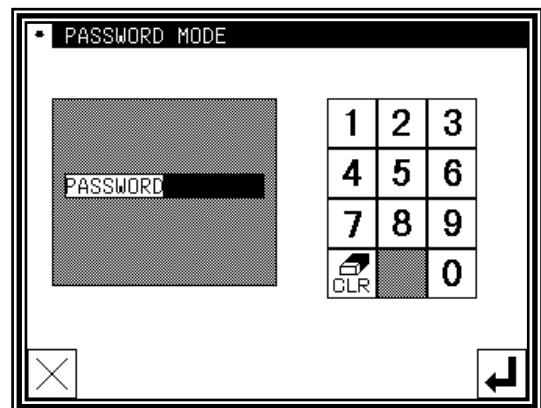

 **Combination mode**

It is possible to combine and connect some stitching data.

Combination: It is possible to combine some stitching data. It is a function to bring some stitching data in one group to sew with the specification order. After sewing each data, the following data is sequentially sewn again by the start signal input.

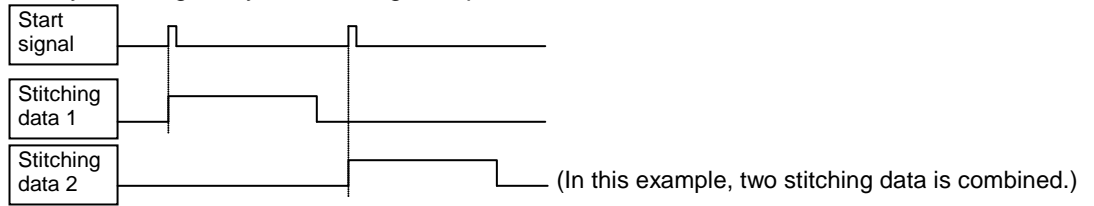

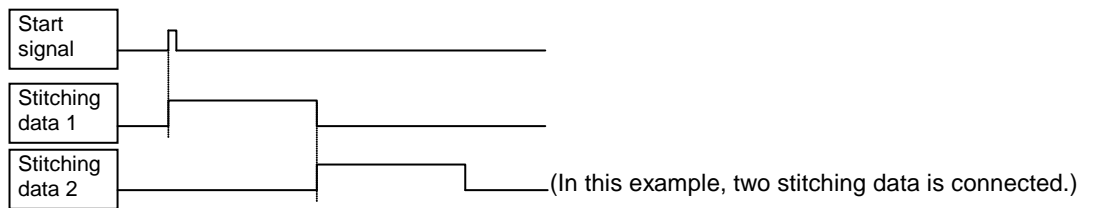

Docking : It is possible to connect some stitching data. It is a function that ties some stitching data like one data to sew with the specification order. Because it treats like one data after the start signal input, it sews continuing individual data one after another.

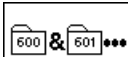

■ **Specifying combination data**

(1) Enter the combination function to press the key  on the function mode screen.

(2) Select place where data is set () and then press

the key 

(Please stuff ahead sequentially and set the stitching data.)

(3) Select the stitching data that wants to add to the combination, and then press the key 

Note From among the data stored in an internal memory, up to 20 stitching data items can be added to the combination. It can not add the stitching data that input second home position cord.

(4) Stitching data (No.800 in this example) has been added.

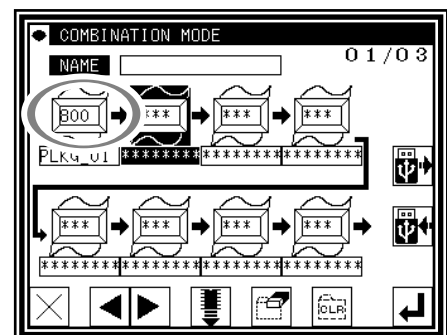
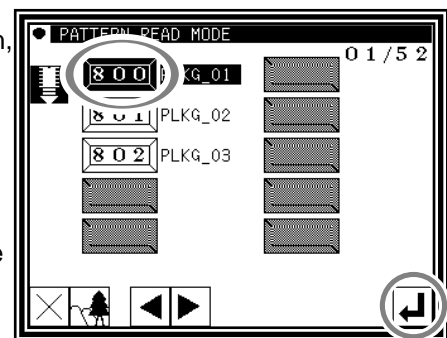
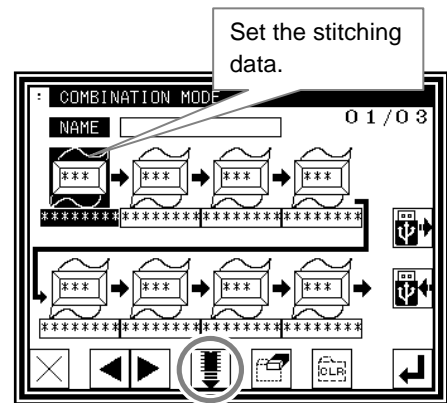

(5) Using the procedure explained in (2) and (3), data items can be added to the combination. (No.801 and 802 in this example)

(6) To write the created combination data into the internal memory, press the key . The combination data can not be used without writing it into the internal memory. The combination data which is written into the USB memory must read from the USB memory before combining.

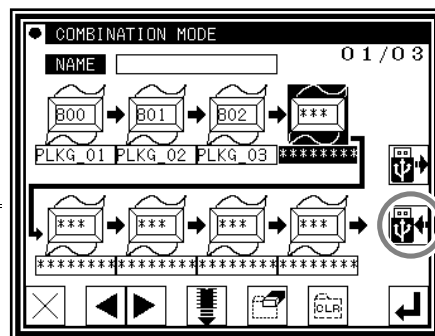

(7) Input name and select form of the combination data at the combination data writing function. (Refer to the item Page [5]-5 which shows the way of changing the internal memory in the USB memory.)

Form



: combination



: docking

(8) Press the key  after selection.

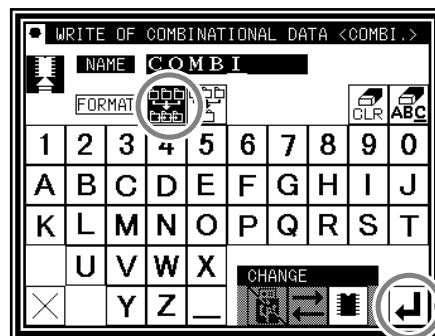



(9) Display returned and the name of combination data is displayed on the operation panel. At that time, the combination data was written into the memory.

(10) When sewing after this operation, press the key .

(It can not be sewn on this display.)

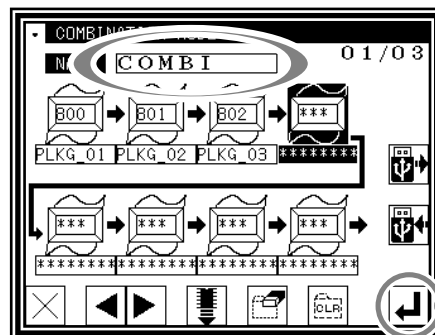
Note If the key  is pressed at this screen, it cancels the data that was set in this mode.



(11) Press the key  on the function mode screen and return to the standard screen.

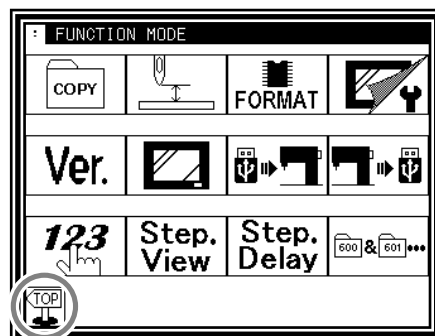

(12) It can be confirmed in the standard screen that the combination data is set. [*1]

(13) Inputting the start signal, it can be started sewing the combination data.

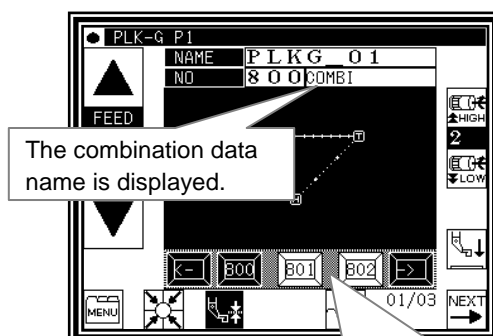



The icon under the image area is changed to the combination data.

[*1] When using the combination data, it is impossible to use usual stitching data. If the setting is returned to normal operation, it is necessary to release the combination data. It explains the method of releasing the combination data by the following chapter.

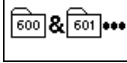
■ Releasing combination data

(1) Enter the combination function to press the key  on the function mode screen.

(2) Press the key  on the combination mode screen.

(3) Press the key  after displaying the confirmation message.

(4) Display changed without combination setting, press the key  without fail.

Note If the key  is pressed at this screen, it cancels the combination releasing.

(5) Press the key  on the function mode screen and return to the standard screen.

(6) It returns to the standard screen.
It is release of the combination data setting completion.

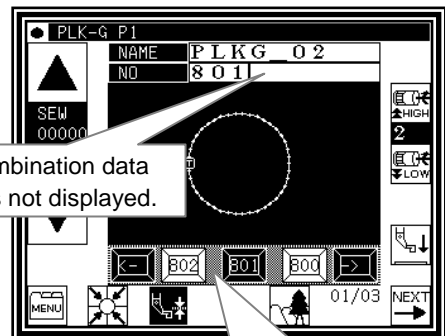
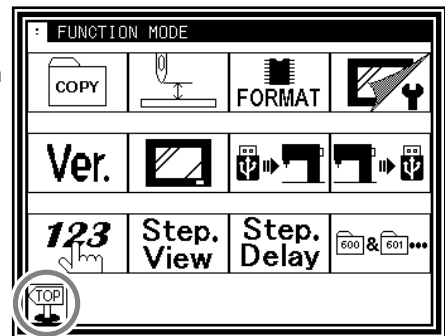
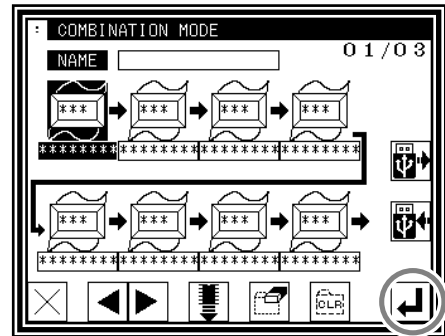
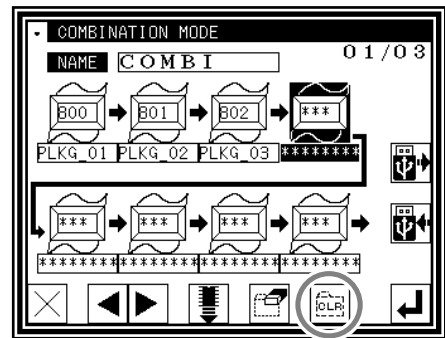

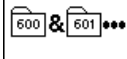

■ Reading combination data

(1) Enter the combination function to press the key  on the function mode screen.

Note When the combination function has already been set, execute reading after releasing combination data. (Please refer the item of Releasing combination data.)

(2) Press the key  to read.

(3) Select the combination data for the purpose intended after changing into the function screen for reading combination data.

The screen can be changed into the individual type such as  combination and  docking.

(Refer to the item Page [5]-2 which shows the way of changing the internal memory in the USB memory.)

(4) Press the key  after selection.

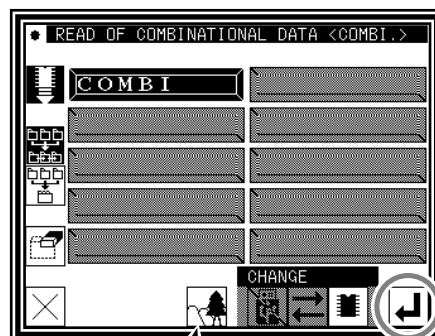
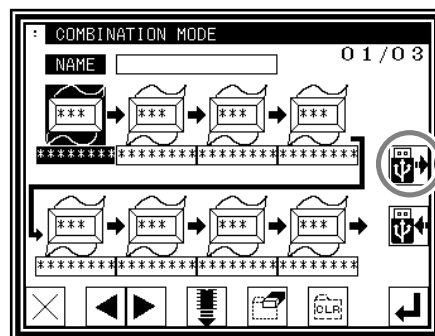

If pressing the button, the image of the combination data is displayed. [*2]

Note The sewing data in the USB memory is overwritten in the internal memory when you read the combination data from the USB memory, when the same sewing data related to the combination data exists. In this case, the message of confirmation is displayed, please operate carefully.

(5) The combination data has been read.

When pressing the key  to do the sewing operation, the standard screen will be returned as the above-mentioned procedure. (Page [13]-7)

Note If the key  is pressed at this screen, the combination data that has been read can be cancelled.

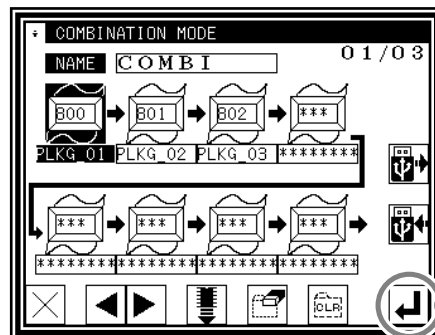

[*2]  The imaging display of the combination data.

When the icon displayed on the read screen for the combination data is pressed, the screen as shown on the right figure will be displayed to confirm the formation of the combination data, which is different from the screen which shows the usual image of sewing data.

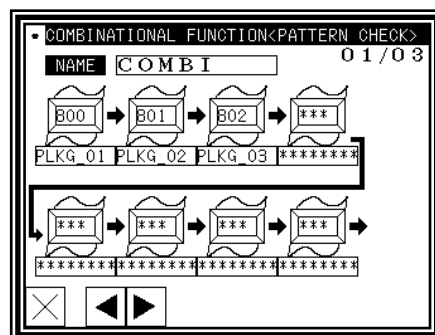

■ Editing combination data

It explains the method of adding and deleting the combination data. It is necessary to write the combination data after editing.

Delete

(1) The data that wants to be deleted is selected on the combination mode screen.

(2) Press the key .

(3) The selected combination data will be deleted and shifted to the left one by one. Stitching data (No.800 in this example) have been deleted.

— Deletion operation end —

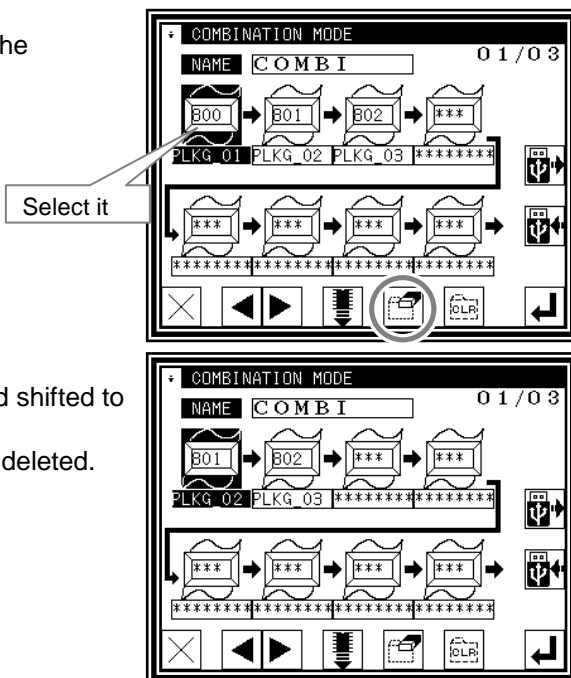

Insert

(1) The place that wants to be inserted is selected on the combination mode screen.

(2) Press the key .

(3) Select the stitching data which you want to add to the combination, and then press the key .

(4) The selected combination data will be inserted and shifted to the backward one by one. Stitching data (No.801 in this example) has been added.

— Insertion operation end —

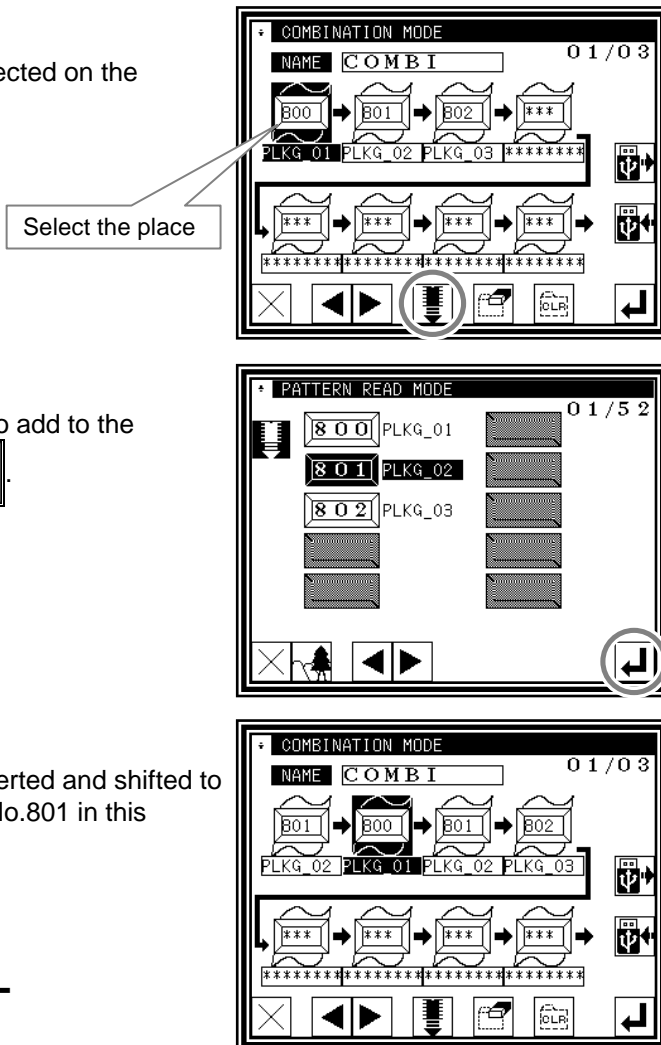

■Deleting combination data

(1) Press the key  on the combination mode screen.

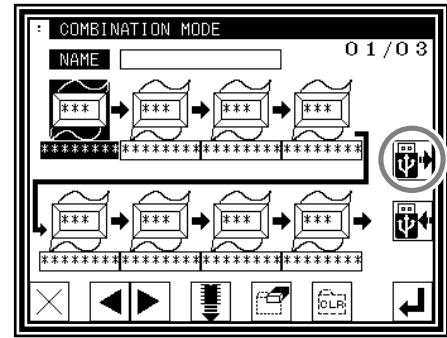



(2) The data that wants to be deleted is selected on the reading combination data screen.
(Refer to the item Page [5]-2 which shows the way of changing the internal memory in the USB memory.)

(3) Press the key  after selection.

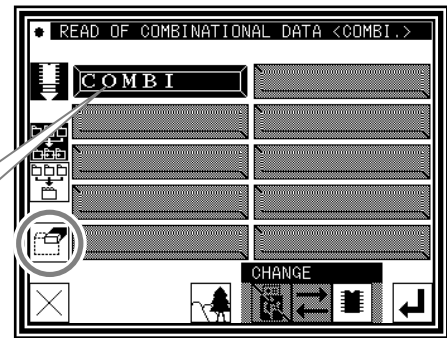
Select it



(4) Press the key  after displaying the confirmation message.

(5) Press the key , it returns to the former screen.

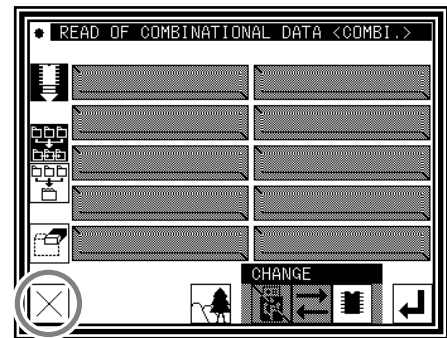

(6) Press the key  on the combination mode screen.

Note If the key  is pressed at this screen, it cancels the combination deleting.

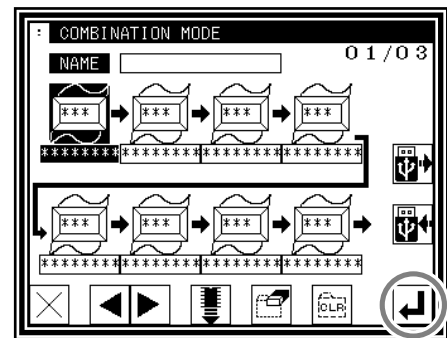

— Deletion operation end —

■ Precaution of the combination data

The individual sewing data comprising the combination data have to exist in the internal memory to sew the combination data. If the sewing starts under the condition that the sewing data comprising the combination data have been deleted, the message will be displayed at the point which is nonexistent sewing data and the sewing operation will stop. As a countermeasure, return the deleted data into the internal memory from the USB memory saved for backup or save it again after deleting the combination data if not required.

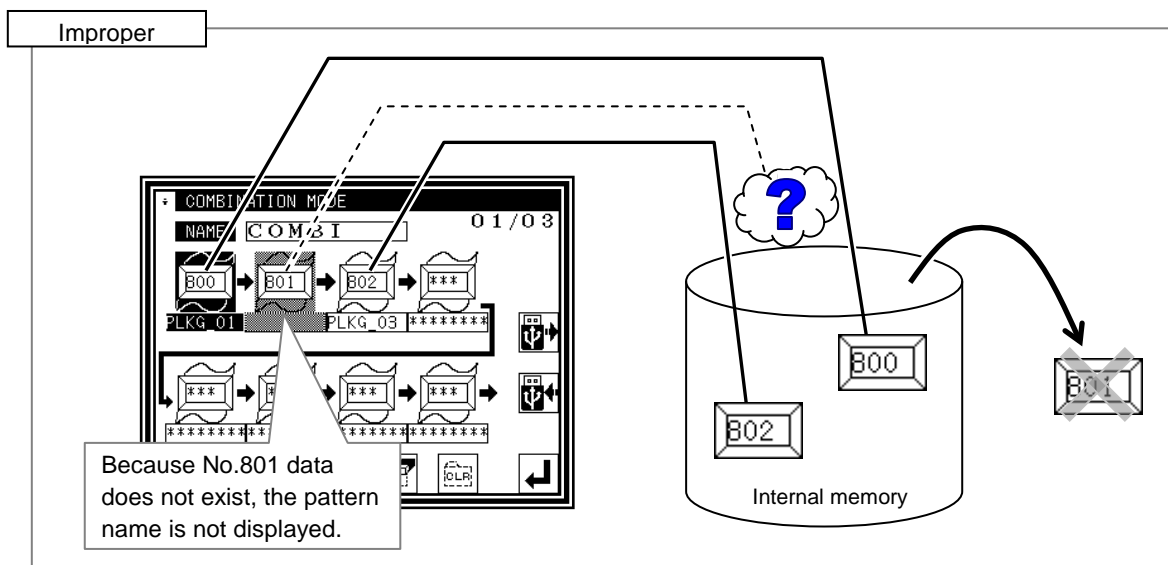
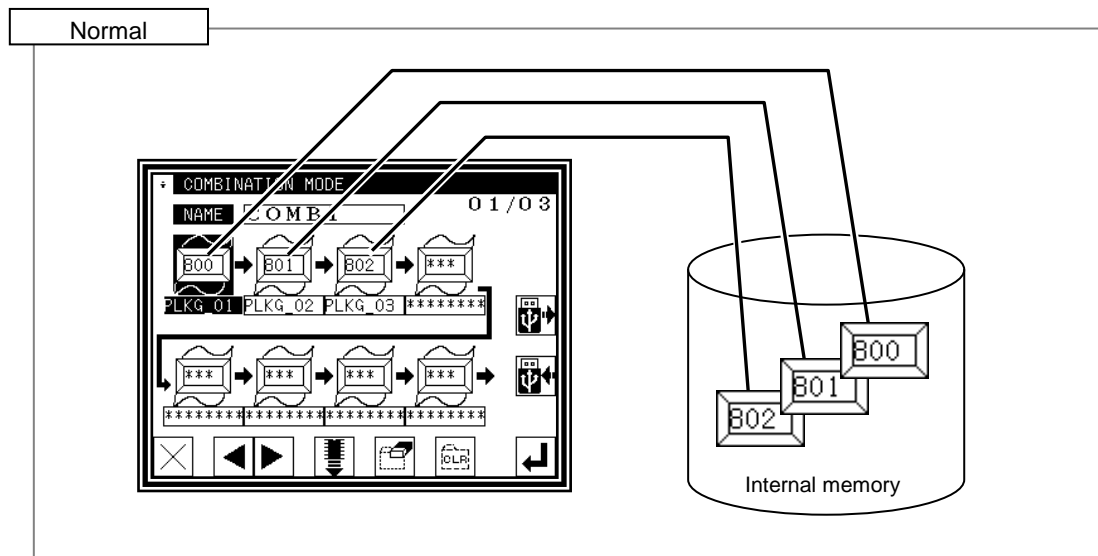

[14] Input/output setting mode

1.Outline

■List of input/output setting modes



Input signal confirmation (Be careful! The sewing machine is ready for operation.)



Output signal confirmation (Be careful! The sewing machine is ready for operation.)

Home position/encoder/detector confirmation
(Be careful! The sewing machine is ready for operation.)

Input setting (Custom input)

Output confirmation (Custom output)

■Entering the input/output setting mode

► Press  and  on the Standard screen, and open the Input / Output Setting Mode screen.

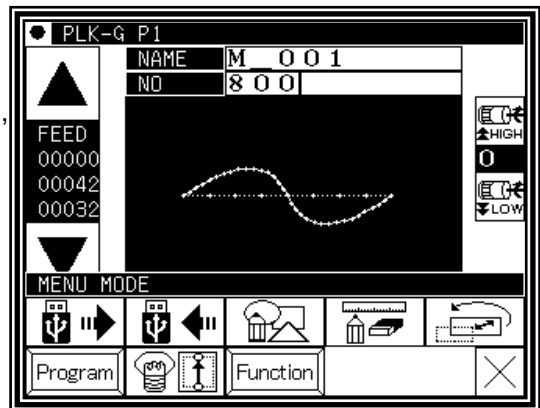

■Input / Output Setting Mode screen

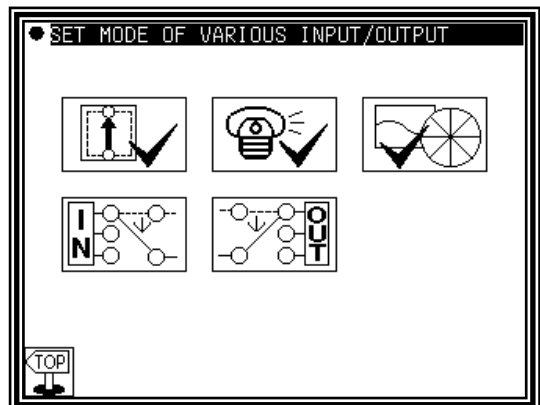

2.Explanation of input/output setting mode

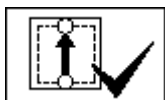

Input signal confirmation

The ON/OFF status of the input signal can be confirmed.

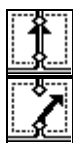

Indicates that the input signal is ON.

Indicates that the input signal is OFF.

[Memo] Input ON/OFF display might be concealed by the error message's giving priority according to the kind of the input or other conditions and being displayed.



Caution Be careful! The sewing machine is ready for operation.

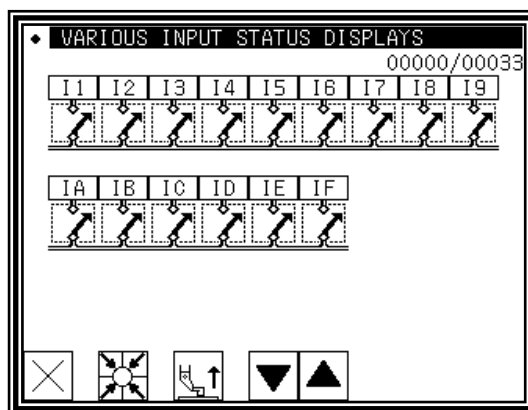

Output signal confirmation

The output signal can be confirmed.

The [1] Status reference mode and the [2] Test output mode are available. Press the mode changeover icon to change the screen.

[1]Status reference mode

The current output status can be confirmed.



Indicates that the output signal is ON.



Indicates that the output signal is OFF.

[2]Test output mode

The signal for which the icon is pressed will be output as a test.



Indicates that the output signal is ON.



Indicates that the output signal is OFF.

[Memo] Output ON/OFF display might be concealed by the error message's giving priority according to the kind of the output and other conditions and being displayed.



Caution Be careful! The sewing machine is ready for operation.



Caution Be careful !! Please not to bring the hand close to the sewing machine for safety while confirming the output signal.

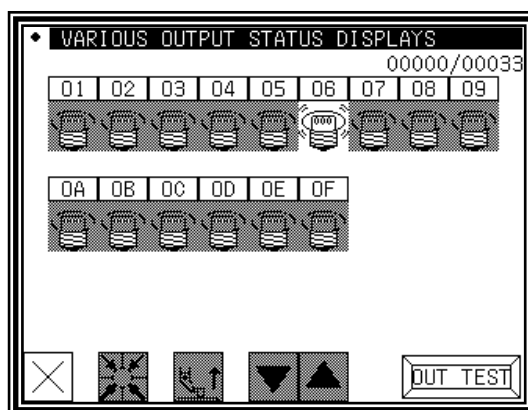
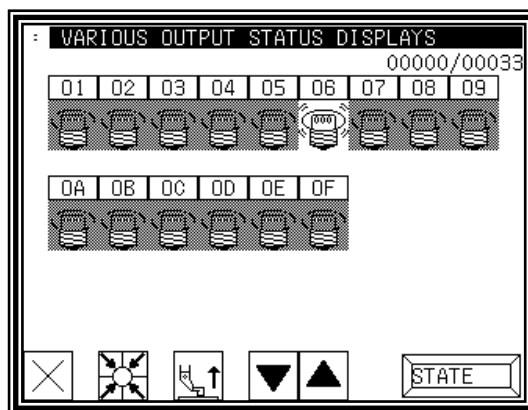

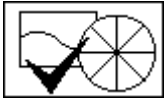

Home position/encoder/detector confirmation

The status of the home position and encoder detector is displayed in an easy-to-read format.

- The detector angle is the angle from the detected DOWN position.
- The encoder color will be alternately highlighted.

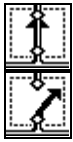

This means detection.

This means non-detection.

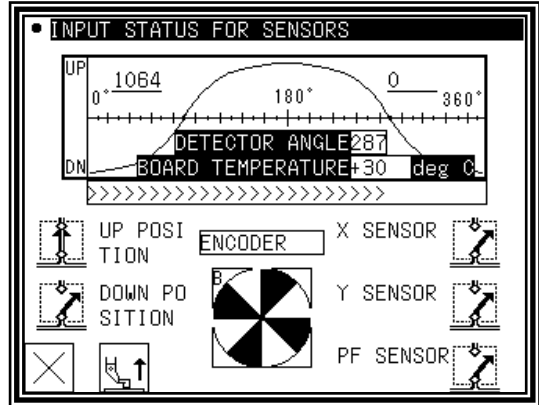

[Memo] Each display might be concealed by the error message's giving priority according to the situation and being displayed. The magnetic of pulls motor is released when entering this mode. When the starting point return/the drive signal enters, the magnetic of pulls motor is turned on again.



Caution Be careful! The sewing machine is ready for operation.

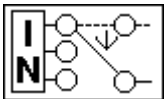

Input setting (Custom input)



[Password function]

(1) Input Customize Setting screen

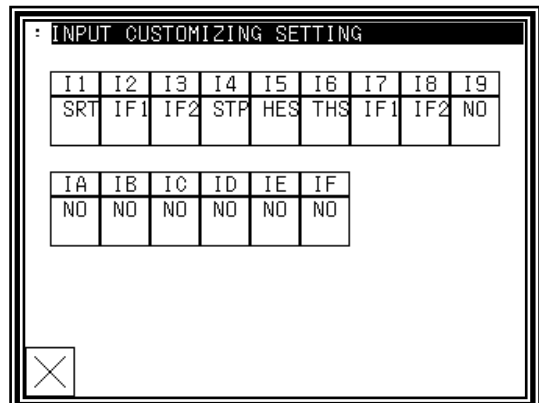
- ▶ Press the physical input RAM (I1 to I9, IA to IP) to be customized. The Function Section screen will open.
- ▶ Box which setting is changed from initial setting is displayed in reverse.



(2) Function Selection screen

- ▶ Press the   icons and select the signal type. (In this case, "SRT" is selected.) (Refer to 3. Input signal setting table for details on the signal types.)
- ▶ To make detailed settings, press the "Details setting" icon.

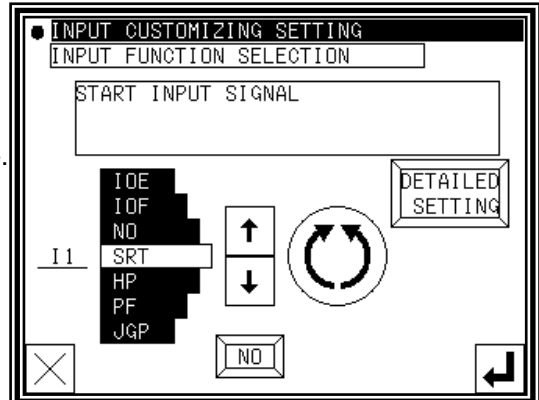

(3) Details Setting screen

- ▶ Change the logic of the input signal. (Normal/reversed)
- ▶ Change the operation of the input signal. (Normal/alternate)
- ▶ Press the  to fix the setting. (The previous screen will open.)

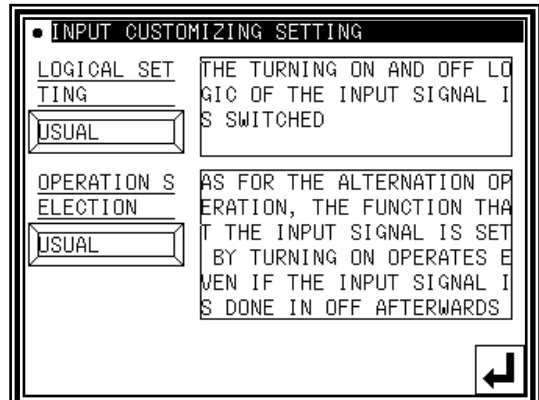

[Memo] Refer to [Control unit] Page [8]-3 for details on the signal logic and operation.

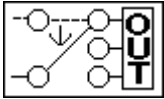



Output confirmation (Custom output) [Password function]

(1) Output Customize Setting screen

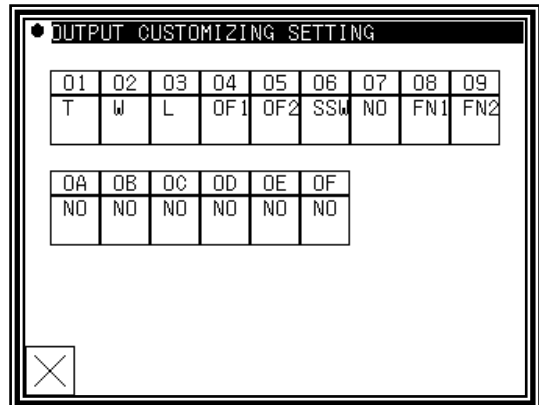
- ▶ Press the physical output RAM (O1 to O9, OA to OO) to be customized. The Function Section screen will open.
- ▶ Box which setting is changed from initial setting is displayed in reverse.



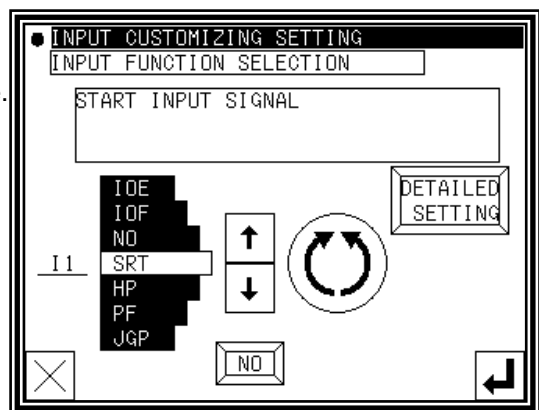

(2) Function Selection screen

- ▶ Press the   icons and select the signal type. (In this case, "T" is selected.) (Refer to 4. Output signal setting table for details on the signal types.)
- ▶ To make detailed settings, press the "Details setting" icon.



(3) Details Setting screen (1)

- ▶ Change the logic of the output signal. (Normal/reversed)
- ▶ Change the operation of the output signal. (Normal/alternate)
- ▶ The Details Setting screens (1) to (3) are available. Press   to change the screen.

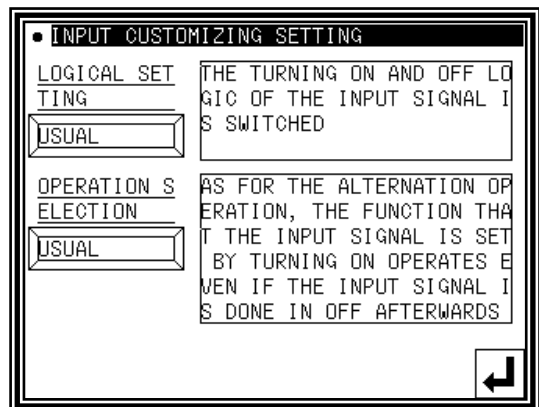

(4) Details Setting screen (2)

- ▶ Set the chopping duty. (Eight types)
- ▶ Set the full wave output time. (0 to 6553.5ms)

[Memo] Refer to [Control unit] Page[8]-4 for details on the signal logic and chopping.

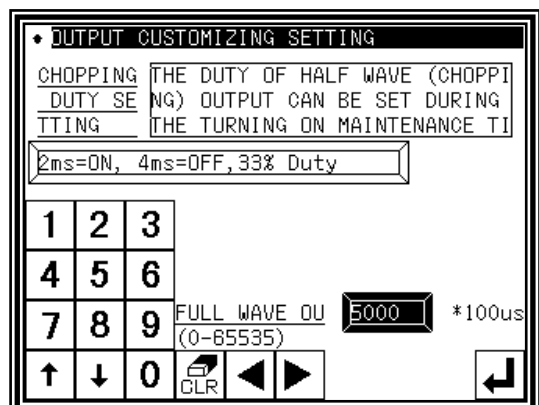

(5)Details Setting screen (3)

- ▶ Set the ON delay.
(Valid/Invalid, delay time (0 to 6553.5ms))
- ▶ Set the OFF delay.
(Valid/Invalid, delay time (0 to 6553.5ms))
- ▶ Press the  to fix the setting.
(The previous screen will open.)

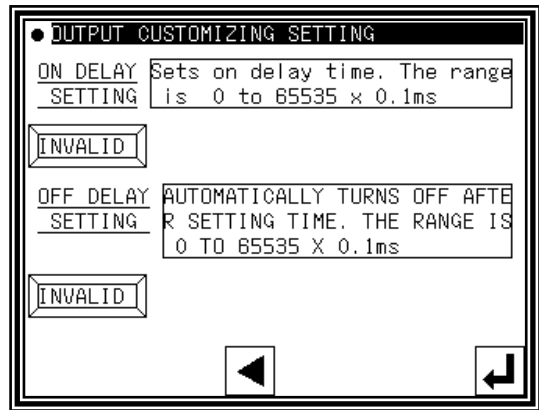

3. Input signal setting table

| Code | Function | Specifications |
|---------|--|--|
| FSP | Clamp all step ON signal | Whenever FSP input is on, clamp output [1],[2],[3],[4],[5],[6],[7],[8] turned on one by one. However, when [Program mode > Clamp output > number of effective clamp (FN)] is set to 1, FSP input is ineffective. |
| FSM | Clamp all step OFF signal | Whenever FSM input is on, clamp output [8],[7],[6],[5],[4],[3],[2],[1] turned off one by one. However, when [Program mode > Clamp output > number of effective clamp (FN)] is set to 1, FSM input is ineffective. |
| FP1 | Clamp division1 step ON signal | Whenever FP1 input is on, clamp output [1],[2],[3],[4] turned on one by one. |
| FM1 | Clamp division1 step OFF signal | Whenever FM1 input is on, clamp output [4],[3],[2],[1] turned off one by one. However [Program mode> clamp output block division number setting (OFB)] is set to no or set to 4, or [number of valid clamp setting (F21N)] is set to 1, FM1 input is ineffective. |
| FP2 | Clamp division2 step ON signal | Whenever FP2 input is on, clamp output [5],[6],[7],[8] turned on one by one. |
| FM2 | Clamp division2 step OFF signal | Whenever FM2 input is on, clamp output [8],[7],[6],[5] turned off one by one. However [Program mode> clamp output block division number setting (OFB)] is set to no or set to 4, or [number of valid clamp setting (F22N)] is set to 1, FM2 input is ineffective. |
| IFR | All clamp output clear signal | If IFR signal is on, all clamp outputs are turned off. |
| A2F | Pneumatic two-step clamp switch input signal | Whenever A2F input is on, following operation (1), (2), (3) is repeated. This signal is effective when [Program mode > Setting for Pneumatic two-step clamp(AF2)] is on. <div style="border: 1px solid black; padding: 5px; width: fit-content; margin: 10px auto;"> <p>(1)When A2F input is on first time, AFL output is turned on. (2)When A2F input is on second time, AFH output is turned on. (3) When A2F input is on third time, AFE output is turned on.</p> </div> |
| IF1~IF8 | Clamp input signal 1 ~ 8 | When IF1 input is on, OF1 output is turned on. When IF1 input is on again, OF1 output is turned off. (same from IF2 toIF8) |
| F1C~F8C | Clamp output prohibition signal 1 ~ 8 | When F1C input is on, OF1 output is prohibited. (same from F2C to F8C) |
| OFC | All clamp output cancel signal | When OFC input is on, OF1 to OF8 outputs are prohibited. |
| WC | Wiper output cancel signal | When WC input is on, W output is prohibited. |
| TC | Trimmer output cancel signal | When TC input is on, Thread trimmer sequence output T, L and W is prohibited. |
| S6 | Thread trimming protection signal | When S6 input is on while machine is driving, the machine is stopped and when S6 input is off, the machine start driving again. When S6 input is on while thread trimming operation, machine is stopped after trimming. |
| HPC | Home positioning prohibition signal | When HPC is ON, home returning operation by the home positioning icon or HP signal is prohibited. |
| TH2 | Upper thread sensor input signal 2 | When setting of [Program mode > Needle thread breaking sensor 2 ON/OFF] is on, the signal can be used for thread breakage detection input (channel 2) |
| THS | Upper thread sensor input signal | When setting of [Program mode > Needle thread breaking sensor ON/OFF] is on, the signal can be used for thread breakage detection input. |
| ARS | Less pressure detection signal | When ARS input is on, all operation is interrupted, and error [E-025] is displayed. (Returns by power supply re-turning on) |
| IO0~IOF | General purpose input 0 ~ F | When IO0 input is on, OT0 output is turned on at the same time. (same from IO1 to IOF) |
| NO | No operation signal | Anything does not operate, if NO input is turned on. |
| SRT | Start signal | When SRT input is on, sewing operation is started. However, when clamp output is turned off, this signal is invalid. |
| HP | Home position returning signal | When HP input is on, home position returning operation is executed. However, please note there is a timing that becomes invalid, for example while machine is running. |
| PF | Presser foot signal | When PF input is on, The presser foot will return to home position. When PF input is on again, presser foot goes to down position. |
| JGP | JOG plus signal | When JGP input is on, XY table is moved in positive direction according to the pattern. |
| JGM | JOG minus signal | When JGP input is on, XY table is moved in negative direction according to the pattern. |
| STP | Halt signal | When STP input is on, machine is stopped. |

< sequel to INPUT SIGNAL >

| Code | Function | Specifications |
|------|--|---|
| BC | Fixed angel (rotation/reverse rotation) signal | To confirm the needle thrust position, the needle is stopped just before the sewing material. Whenever BC input is ON, operation of [rotation] → [reverse rotation] → [rotation] is repeated. When the start switch is on afterwards, following sewing operation is started. However, if the following data is non stitch feed, the message [M-020] is appeared, in this case please move the needle to up position and re-turning on the start switch. Setting value of fixed angle can be set in the [Function mode > Needle down angle setting]. |
| CCL | Counter clear signal | When CCL input is on, UP/DOWN counter is cleared. |
| SRC | Start cancel signal | When SRC input is on, sewing operation with Stringhalt is prohibited. |
| CCU | Up counter clear signal | When CCU input is on, UP counter is cleared. |
| CCD | Down counter clear signal | When CCD input is on, DOWN counter is cleared. |
| UAD | Up counter addition signal | When UAD input is on, 1 is added to UP counter |
| UDC | Up counter subtraction signal | When UDC input is on, 1 is subtracted from UP counter |
| DAD | Down counter addition signal | When DAD input is on, 1 is added to DOWN counter |
| DDC | Down counter subtraction signal | When DDC input is on, 1 is subtracted from DOWN counter |
| KNK | Signal that invalidates MENU icon | When KNK is on, "MENU" icon becomes invalid. |
| RNK | Signal that invalidates "pattern read" icon | When RNK is on, "pattern read" icon becomes invalid. |
| WNK | Signal that invalidates "pattern write" icon | When WNK is on, "pattern write" icon becomes invalid. |
| INK | Signal that invalidates "teaching input" icon | When INK is on, "teaching input" icon becomes invalid. |
| MNK | Signal that invalidates "teaching modification" icon | When MNK is on, "teaching modification" icon becomes invalid. |
| CNK | Signal that invalidates "teaching conversion" icon | When CNK is on, "teaching conversion" icon becomes invalid. |
| PNK | Signal that invalidates "program mode" icon | When PNK is on, "program mode" icon becomes invalid. |
| NNK | Signal that invalidates "IN/OUT setting" icon | When NNK is on, "IN/OUT setting" icon becomes invalid. |
| FNK | Signal that invalidates "function mode" icon | When FNK is on, "function mode" icon becomes invalid. |
| SNK | Signal that invalidates "speed" icon | When SNK is on, "speed" icon becomes invalid. |
| P01 | Pattern number switch signal +1 | When P01 is on, pattern data number is switch to 801 (800+1). |
| P02 | Pattern number switch signal +2 | When P02 is on, pattern data number is switch to 802 (800+2). |
| P04 | Pattern number switch signal +4 | When P04 is on, pattern data number is switch to 804 (800+4). |
| P08 | Pattern number switch signal +8 | When P08 is on, pattern data number is switch to 808 (800+8). |
| P16 | Pattern number switch signal +16 | When P16 is on, pattern data number is switch to 816 (800+16). |
| P32 | Pattern number switch signal +32 | When P32 is on, pattern data number is switch to 832 (800+32). <div style="border: 1px solid black; padding: 10px; margin: 10px 0;"> <p style="text-align: center;">< When you want to change to other patterned numbers ></p> <p>ex.1) pattern number to 803 turns on P01 input and P02 input $P01 (+1) + P02 (+2) + 800 = 803$</p> <p>ex.1) pattern number to 811 turns on P01, P02 and P08 input $P01 (+1) + P02 (+2) + P08 (+8) + 800 = 811$</p> </div> <p>*Pattern number can be changed within the range from 800 to 863. *P01,P02,P04,P08,P16,P32 is effective when [Pattern select function by external signal(APC)] has been set to ON.</p> |
| IFA | DO NOT USE | |
| HES | Machine head tilting detection signal | When HES input is on, message [M-038] is displayed. |
| I_g | DO NOT USE | |
| I_A | DO NOT USE | |

< sequel to INPUT SIGNAL >

| Code | Function | Specifications |
|---------|------------------------------|---|
| SP0~SP9 | Speed dial signal | Speed dial value is switched to 0~9. |
| SPU | Speed up signal | Speed dial value is increased +1. |
| SPD | Speed down signal | Speed dial value is decreased -1. |
| CK1 | Cassette jig sensor 1 signal | When CK1 and CK2 inputs is on, OF1 output turn on. |
| CK2 | Cassette jig sensor 2 signal | *CK1 and CK2 is effective when [Cassette jig function ON/OFF(CHK)] and [Cassette jig sensor ON/OFF(CSN)] has been sets to ON. |

4. Output signal setting table

| Code | Function | Specifications |
|---------|--|--|
| OT0~OTF | General purpose output 0 ~ F | When IO0 is on, OT0 output at the same time(same from OT1 to OTF) |
| FN1~FNH | Function code output 1 ~ H | When FUN1 code is read while sewing operation, FN1 output is reversed. (same from FN2 to FNH) |
| OF1~OF8 | Clamp output 1 ~ 8 | When IF1 is on, OF1 output is reversed (same OF2 to OF8) |
| NO | [NO]output | Nothing is done |
| T | Trimmer output | Trimming operation is done |
| L | Thread tension release output | Thread tension release operation is done |
| W | Wiper output | Wiper operation is done |
| PF | Presser foot output | Presser foot operation is done |
| AFL | Pneumatic two-step switch clamp low pressure output | When A2F input is on first time, AFL output is turned on. Setting is effective when [Program mode > Clamp > Pneumatic two-step switch clamp ON/OFF (AF2)] is on. |
| AFH | Pneumatic two-step switch clamp high pressure output | When A2F input is on second time, AFH output is turned on. Setting is effective when [Program mode > Clamp > Pneumatic two-step switch clamp ON/OFF (AF2)] is on. |
| AFE | Pneumatic two-step switch clamp excess pressure release output | When A2F input is on third time, AFE output is turned on. Setting is effective when [Program mode > Clamp > Pneumatic two-step switch clamp ON/OFF (AF2)] is on. |
| DHP | Home position output | When XY table is sopped on the home position, DHP output is turned on. |
| D2H | Second home position output | When XY table is sopped on the second home position, DHP output is turned on. |
| RED | Preparation ready output | When the machine is ready state (when clamp output is on), RED output is turned on. When machine is start sewing, RED is turned off. |
| DSW | Sewing in progress output | When the machine is sewing, DSW output is turned on. When machine is stopping on the home position, DSW output is turned off. |
| SP | Sewing machine rotation start output | After non stitch feed, when the sewing machine start to rotate, SP output is turned on. When home positioning is executed, SP output is turned off. |
| TSE | Trimming start output | When trimming sequence (down position) is started, TSE outpu is turned on. When trimming sequence is finished (when all the outputs of T, L and W are turned off), TSE output is turned off. |
| END | Sewing completion output | When a sewing pattern operation is finished, END output is turned on. When the next sewing is started, END output is turned off. |
| DCS | Halt code output | When the halt code data (USTP, DSTP) is read while sewing, DCS output is turned on. When the machine restarts DCS output is turned off. |
| DST | Halt in progress output | When the machine is on halt state, DST output is turned on. When the machine restarts DST output is turned off. However, it is not output while stopping by the USTP code or the DSTP code. |
| HPO | Home returning in progress output | While the operation of home returning by the home positioning icon or HP signal, HPO outpu is turned on. |
| ERR | Error output | When the error or message is displayed on the operation panel, ERR output is turned on. |
| CUE | Count up completion output | When the current value of up counter is reached at counter set value, CUE output signal is turned on. When the current value is cleared, CUE output is turned off. |
| CDE | Countdown completion output | When the current value of down counter is reached at 0, CDE output signal is turned on. When the current value is initialized, CDE output is turned off. |
| DTS | Halt in progress output after upper thread sensor detection | When the machine is on halt state with thread breakage, DTS output is turned on. When the machine restarts, DTS output is turned off. |
| --1 | DO NOT USE | |
| DRT | Sewing machine rotation in progress output | While the machine is rotating, DRT output is turned on. (includes rotation in winding mode) |
| DN | Down position output | When the needle is down position, DN output is turned on. |
| CB | Buzzer output | While the buzzer in the operation panel is on, CB output is turned on. (including count up/countdown message display) |
| UP | Up position output | When the needle is up position, UP output is turned on. |
| PWR | Power on output | While power supply is on, PWR output signal is turned on. |
| PUS | Presser hoot home position output | While presser foot is on the home position, PUS output is turned on. |
| MSG | Message display output | When the message is displayed on the operation panel, ERR output is turned on. |
| OP1 | Option output 1 | General purpose output signal 1 |
| OP2 | Option output 2 | General purpose output signal 2 |
| SSW | Halt signal being on output | SSW is turned on during power supply is on. However, input signal STP turns on SSW is turned on with blinking. |
| MOV | Sending table's moving output signal | Turns on during XY table is moving. (It does not turn on when automatic sewing operation) |

[15] Program mode

MEMO For each function explanation, please refer to [16] Program mode list

1. Setting methods

■ Entering the program mode

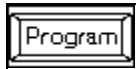
▶ Press  and  on the Standard panel, and open the Program Mode panel.

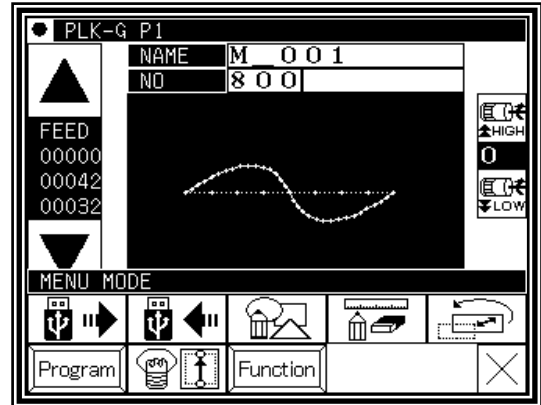

■ Program Mode panel

This panel is used to select the program mode. There are several mode selection pages.

Press the   icons to change the page.

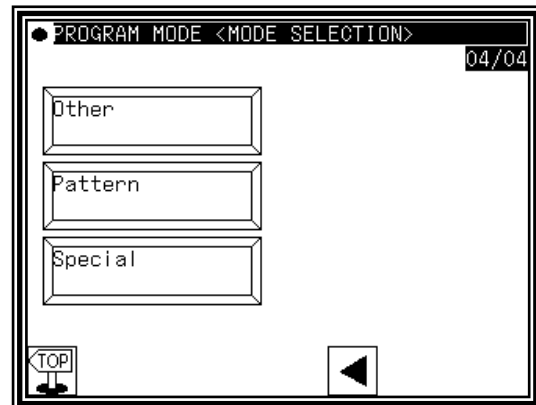
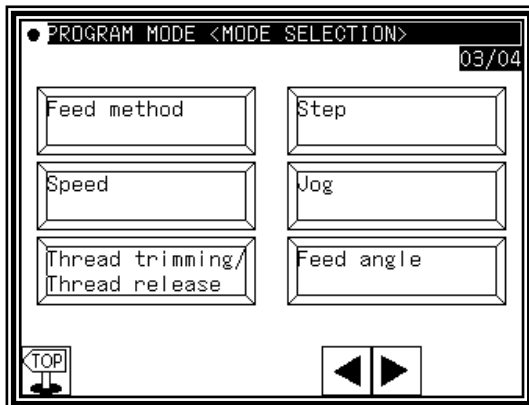
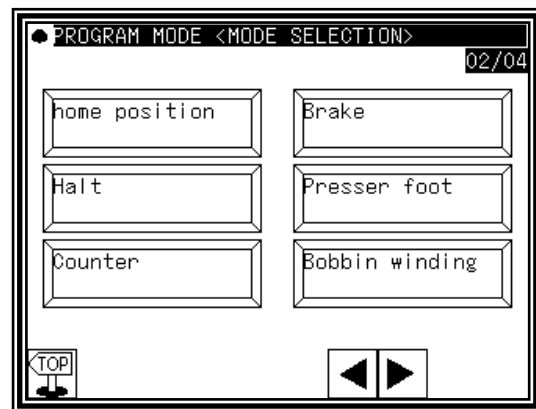
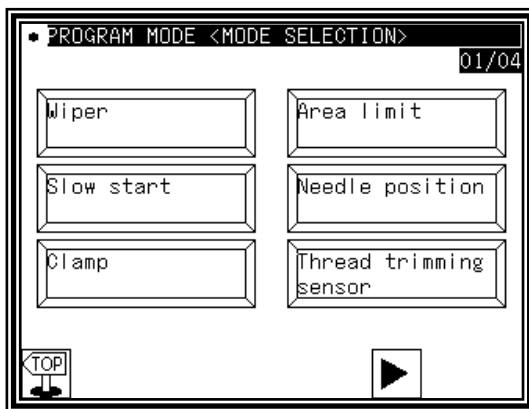

■ Example of setting

(1) Selection of mode

- ▶ When the icon for the mode to be set is pressed, the "Setting Selection panel " will open.
(In this example, "HALT" is pressed.)

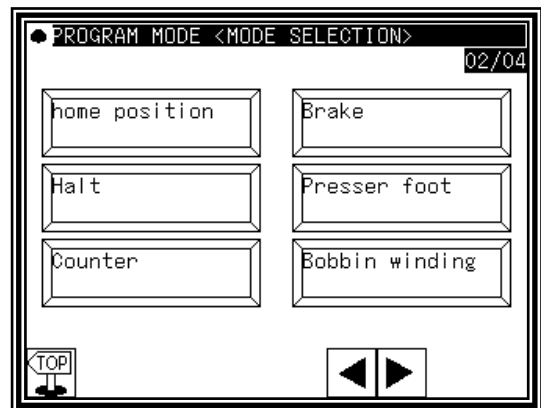

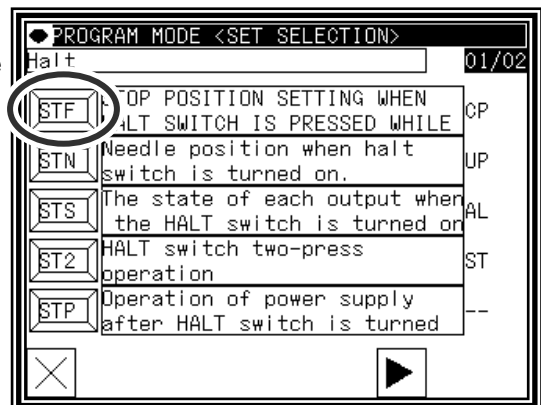

(2) Selection of function

- ▶ When the icon for the function to be set is pressed, the "Setting Value Change panel " will open.
(In this example, "STF" is pressed.)



(3) Changing setting value

- ▶ After changing setting value (selecting status icon)(Here, pressing [ST]), press  to confirm setting.

MEMO To show all explanation of these status icon, press .

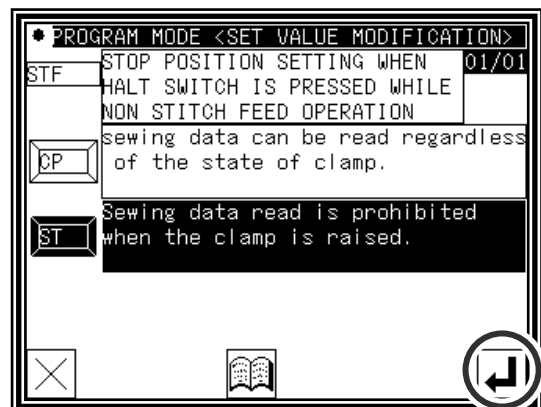

(4) Checking function setting change

- ▶ Return [Setting selection] window.

After check setting value press .

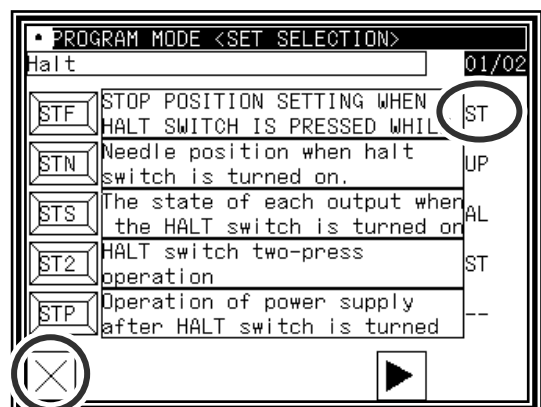

(5) Return to the mode selection screen

- ▶ If some setting has been changed, difference list will be appeared in the mode selection screen
- ▶ To return to the standard screen, press .
- ▶ To show different list, press [Difference] icon.

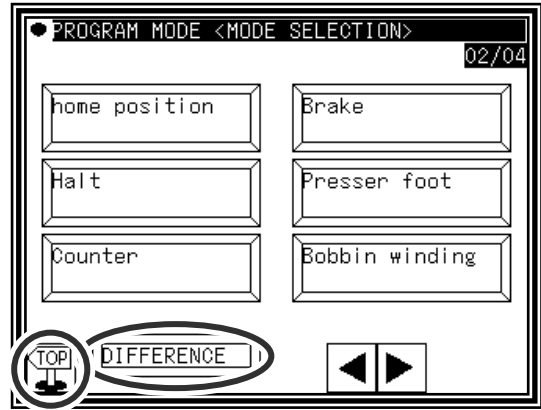

(6) Checking different list

- ▶ Press [Difference] icon.
- ▶ The list where the setting has been changed are displayed. Each list icons are selectable and setting value can be changed again from this screen.
- ▶ To initialize all settings, press [INIT. ALL]. To initialize only selected items, press the frame of the explanation (frame will be displayed in reverse), then press [SELECT INIT].

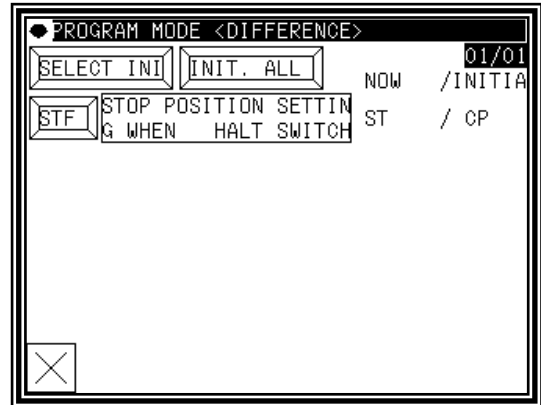

MEMO Type of setting

There are few types of setting. One is status selection type like described above. Other is ON/OFF setting type, or numeral setting type. In the numeral setting type, numeric button will be appeared.

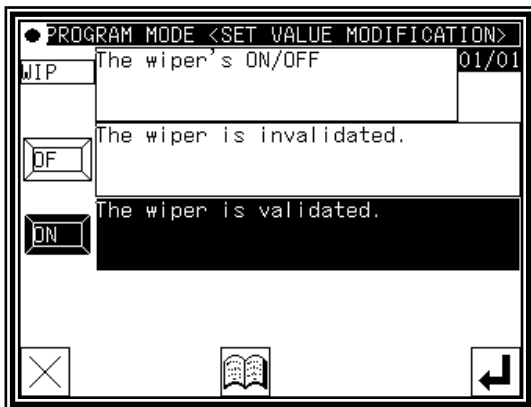

Example of ON/OFF setting type

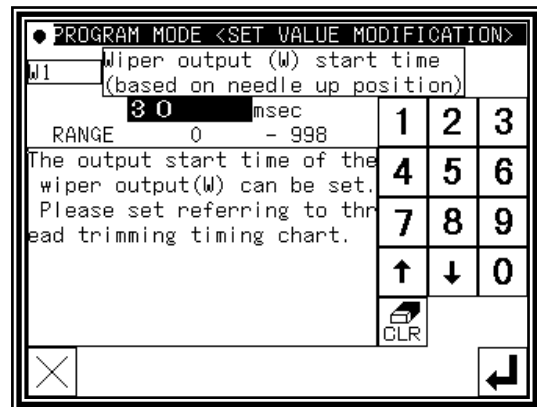

Example of numeral setting type

2. "System, setting file write" and "Setting file read"

It is possible to restore easily by storing setting changed program mode on the USB memory to return later.

■ System, setting file write

(1) Entering the function mode

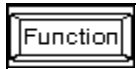
- ▶ Press  and  on the Standard screen, and open the Function Mode screen.

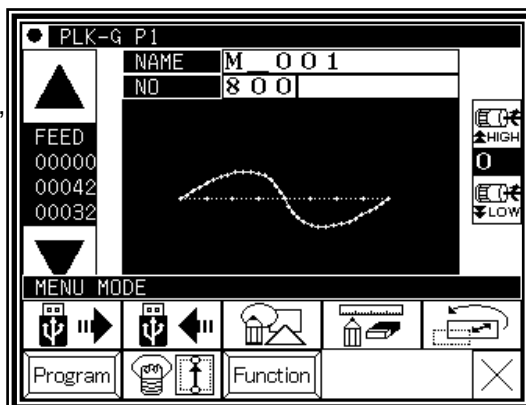

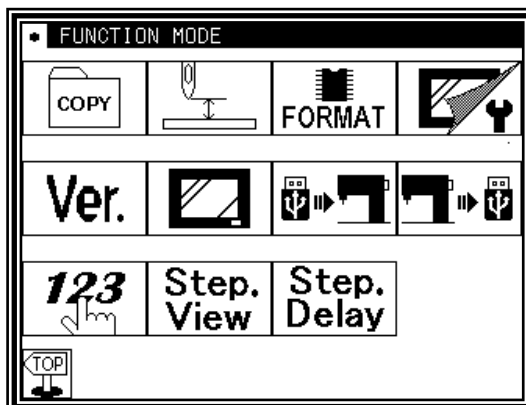

(2) Function mode screen

- ▶ Press .



(3) Writing setting file

- ▶ Press , then press .

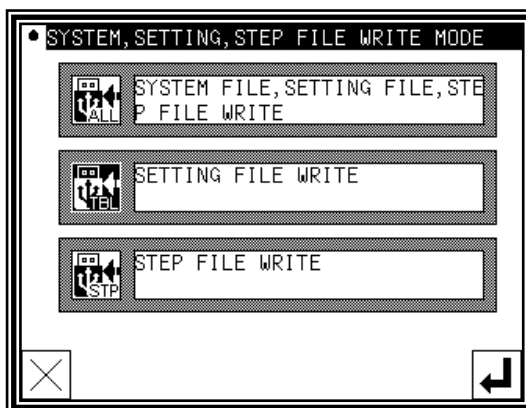

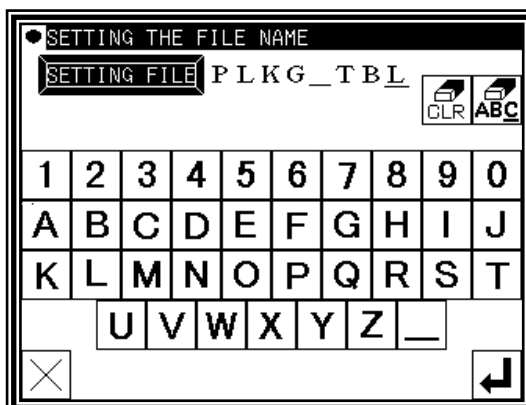

(4) Naming setting file

- ▶ Insert the USB memory to the connector.
 ▶ Name the setting file by character buttons, then press .
- ▶ Setting file will be preserved into the [USER_system] folder in the USB memory.
 Please note if the same name is exist, it is overwritten.



■Setting file read

(1)Entering the function mode

- ▶ Press  and  on the Standard screen, and open the Function Mode screen.

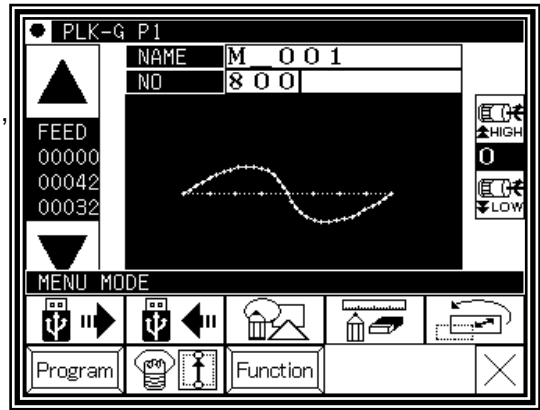

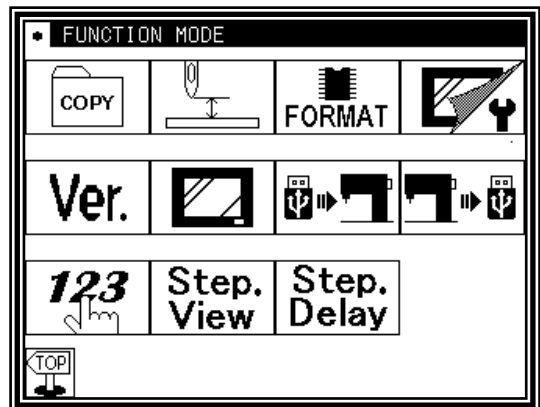

(2)Function mode screen

- ▶ Press .



(3)Reading setting file

- ▶ Insert USB memory where the sewing data is preserved to the connector.
▶ Press , then press .

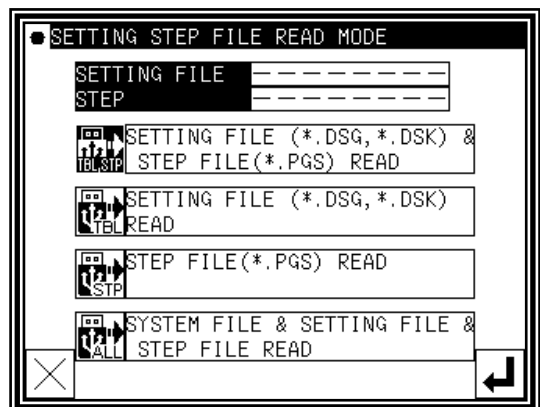

(4)Selecting setting file

- ▶ Select setting file by using up and down arrow, then press .

MEMO Reading is proceeded by overwrite mode. Original setting data will be erased.

- ▶ When message like as [Please turn the power supply off] is displayed, follow the instruction.

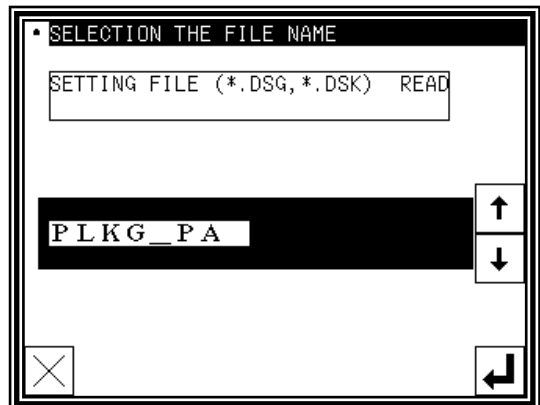

[16] Program mode list

1. Wiper

| Function | Unit | Setting range | Specification |
|--|--|---------------|--|
| WIP Wiper ON/OFF | Valid/invalid of the wiper output is switched. | | |
| | - | OF | The wiper is invalidated. |
| | | ON | The wiper is validated. |
| W1 Wiper output (W) start time (based on needle up position) | ms | 0 ~ 998 | The output start time of the wiper output(W) can be set. Please set referring to thread trimming timing chart. |
| W2 Wiper output (W) start time | ms | 0 ~ 998 | The output time of the wiper output(W) can be set. Please set referring to thread trimming timing chart. |

2. Slow start

| Function | Unit | Setting range | Specification |
|-----------------------------------|---|---------------------|---|
| SL Slow start ON/OFF | Valid/invalid of the slow start is set. | | |
| | - | OF | The slow start is invalidated. |
| | | ON | The slow start is validated. Slow start will be applied to the start of all stitching (when power is turned ON, during HALT, and during jogging operation, etc.). |
| SLN No. of slow start stitches | stitches | 0 ~ 5 | Number of stitches of the first sewing speed (slow start) can be set. |
| S Slow start speed | rpm | Maximum speed range | The speed (slow start) of the first sewing can be set. |
| SLS Super slow start ON/OFF | Sets effective/ineffective for super-slow start | | |
| | - | OF | Super slow start is set ineffective |
| | | ON | Super slow start is set effective. When (SL) setting is set effective, the first stitch will start by super-slow speed. |
| SLP Super slow start speed | rpm | 25 ~ 100 | Sets Super slow start speed. |

3. Clamp

| Function | Unit | Setting range | Specification |
|-----------------------------|--|---------------|--|
| RPT Repeat sewing ON/OFF | The repeat sewing operation is set. | | |
| | - | OF | The normal stitching operation is entered. (Repeat sewing RP1-RP8 is invalidated.) |
| | | ON | The repeat sewing RP1-RP8 is validated. |
| RP1 Repeat sewing 1 | RP1: The repeat sewing operation is set. | | |
| | - | OF | The normal stitching operation is entered. (Repeat sewing RP1 is invalidated.) |
| | | ON | The repeat sewing RP1 is validated.(when the (RPT.) setting [ON] only) |
| RP2 Repeat sewing 2 | RP2: The repeat sewing operation is set. | | |
| | - | OF | The normal stitching operation is entered. (Repeat sewing RP2 is invalidated.) |
| | | ON | The repeat sewing RP2 is validated.(when the (RPT.) setting [ON] only) |
| RP3 Repeat sewing 3 | RP3: The repeat sewing operation is set. | | |
| | - | OF | The normal stitching operation is entered. (Repeat sewing RP3 is invalidated.) |
| | | ON | The repeat sewing RP3 is validated.(when the (RPT.) setting [ON] only) |
| RP4 Repeat sewing 4 | RP4: The repeat sewing operation is set. | | |
| | - | OF | The normal stitching operation is entered. (Repeat sewing RP4 is invalidated.) |
| | | ON | The repeat sewing RP4 is validated.(when the (RPT.) setting [ON] only) |
| RP5 Repeat sewing 5 | RP5: The repeat sewing operation is set. | | |
| | - | OF | The normal stitching operation is entered. (Repeat sewing RP5 is invalidated.) |
| | | ON | The repeat sewing RP5 is validated.(when the (RPT.) setting [ON] only) |

<Continuation of [Clamp]>

| Function | Unit | Setting range | Specification |
|--|--|---------------|---|
| RP6 Repeat sewing 6 | RP6: The repeat sewing operation is set. | | |
| | - | OF | The normal stitching operation is entered. (Repeat sewing RP6 is invalidated.) |
| | | ON | The repeat sewing RP6 is validated.(when the (RPT.) setting [ON] only) |
| RP7 Repeat sewing 7 | RP7: The repeat sewing operation is set. | | |
| | - | OF | The normal stitching operation is entered. (Repeat sewing RP7 is invalidated.) |
| | | ON | The repeat sewing RP7 is validated.(when the (RPT.) setting [ON] only) |
| RP8 Repeat sewing 8 | RP8: The repeat sewing operation is set. | | |
| | - | OF | The normal stitching operation is entered. (Repeat sewing RP8 is invalidated.) |
| | | ON | The repeat sewing RP8 is validated.(when the (RPT.) setting [ON] only) |
| WHY Priority of clamp mode | Sets the priority of clamp. | | |
| | - | OF | The movement setting of clamp 1 - clamp 8 can be randomly set. |
| | | ON | The movement of clamp 1 - clamp 8 will be in the order of clamp 1 - clamp 8. |
| FSR All cancel at over-step movement | The method of the clamp up for the step clamp movement is set. | | |
| | - | OF | After all of the clamps have been lowered [ON], the clamps are not raised [OFF] regardless the clamp step input signal is turned [ON]. |
| | | ON | After all of the step clamps have been lowered [ON], when the clamp step input signal is turned [ON] once, all of the clamps are raised[OFF]. |
| 1PD Valid or invalid 1 pedal action | Sets the pedal specification (1 pedal/2 pedals). | | |
| | - | OF | The normal operation (two pedals) is effective. |
| | | ON | 1 pedal action is valid. When start switch is pressed, clamp is lowered and sewing is started automatically. |
| | | PD2 | 1 pedal operation of 03BT specification becomes effective. |
| 1T Start delay setting for 1 pedal action | ms | 0 ~ 5000 | Waiting time between clamp down and start sewing is set |
| 1A Clamp 1 of output on delay setting | ms | 0 ~ 10000 | Sets the time (TA1) from the clamp input 1 ON to clamp output 1 ON. |
| 2A Clamp 2 of output on delay setting | ms | 0 ~ 10000 | Sets the time (TA2) from the clamp input 2 ON to clamp output 2 ON. |
| 3A Clamp 3 of output on delay setting | ms | 0 ~ 10000 | Sets the time (TA3) from the clamp input 3 ON to clamp output 3 ON. |
| 4A Clamp 4 of output on delay setting | ms | 0 ~ 10000 | Sets the time (TA4) from the clamp input 4 ON to clamp output 4 ON. |
| 5A Clamp 5 of output on delay setting | ms | 0 ~ 10000 | Sets the time (TA5) from the clamp input 5 ON to clamp output 5 ON. |
| 6A Clamp 6 of output on delay setting | ms | 0 ~ 10000 | Sets the time (TA6) from the clamp input 6 ON to clamp output 6 ON. |
| 7A Clamp 7 of output on delay setting | ms | 0 ~ 10000 | Sets the time (TA7) from the clamp input 7 ON to clamp output 7 ON. |
| 8A Clamp 8 of output on delay setting | ms | 0 ~ 10000 | Sets the time (TA8) from the clamp input 8 ON to clamp output 8 ON. |
| 1B Clamp 1 of output off delay setting | ms | 0 ~ 10000 | Sets the time (TB1) from the clamp input 1 ON to clamp output 1 OFF. |
| 2B Clamp 2 of output off delay setting | ms | 0 ~ 10000 | Sets the time (TB2) from the clamp input 2 ON to clamp output 2 OFF. |

<Continuation of [Clamp]>

| Function | Unit | Setting range | Specification |
|--|---|---|--|
| 3B Clamp 3 of output off delay setting | ms | 0 ~ 10000 | Sets the time (TB3) from the clamp input 3 ON to clamp output 3 OFF. |
| 4B Clamp 4 of output off delay setting | ms | 0 ~ 10000 | Sets the time (TB4) from the clamp input 4 ON to clamp output 4 OFF. |
| 5B Clamp 5 of output off delay setting | ms | 0 ~ 10000 | Sets the time (TB5) from the clamp input 5 ON to clamp output 5 OFF. |
| 6B Clamp 6 of output off delay setting | ms | 0 ~ 10000 | Sets the time (TB6) from the clamp input 6 ON to clamp output 6 OFF. |
| 7B Clamp 7 of output off delay setting | ms | 0 ~ 10000 | Sets the time (TB7) from the clamp input 7 ON to clamp output 7 OFF. |
| 8B Clamp 8 of output off delay setting | ms | 0 ~ 10000 | Sets the time (TB8) from the clamp input 8 ON to clamp output 8 OFF. |
| OFB The divisions of clamp blocks | 8 clamps can be bundled to blocks. | | |
| | - | NO | Use 8 clamp types in 1 block (OF1-OF8). The following functions become valid: [Setting of valid clamp(FN.)] and [Setting of clamp link (CF.)]. |
| | - | 2 | Use 8 clamps in 2 blocks (OF1-OF4)(OF5-OF8). The following functions become valid: (F21N.) (F22N.) (CF1.) (CF2.). |
| - | 4 | Use 8 clamp types in 4 blocks (OF1,OF2), (OF3,OF4), (OF5,OF6), (OF7,OF8). The following functions become valid: [No. of valid clamp blocks setting(F4BN.)] and [No. of block steps used setting(F4SN.)] | |
| FN Setting for valid number of clamp | - | 1 ~ 8 | [Divisions of clamp (OFB.)] is validated when set to [NO]. Number of outputs (clamp) from [PR1(OF1)] to [PR8(OF8)] can be set. Sewing is possible when all selected number of outputs (clamp) are [ON]. |
| CF Clamp synchronize ON/OFF setting | The [The divisions of clamp (OFB.)] is validated when set to [NO]. | | |
| | - | OF | The clamps are not synchronized. |
| - | - | ON | The clamps are synchronized. (For details, see the timing chart.) |
| F21N Number of valid clamp with clamp block setting (OF1-OF4) | - | 1 ~ 4 | Setting is effective when OFB=[2]. 1:Use clamp output OF1. 2:Use clamp output OF1+OF2. 3:Use clamp output OF1+OF2+OF3. 4:Use clamp output OF1+OF2+OF3+OF4. |
| F22N Number of valid clamp with clamp block setting (OF5-OF8) | - | 1 ~ 4 | Setting is effective when OFB=[2]. 1:Use clamp output OF5. 2:Use clamp output OF5+OF6. 3:Use clamp output OF5+OF6+OF7. 4:Use clamp output OF5+OF6+OF7+OF8. |
| CF1 Clamp synchronize setting with clamp block setting(OF1-OF4) | The [The divisions of clamp(OFB.)] is validated when set to [2]. (For details, see the timing chart.) | | |
| | - | OF | Clamps (OF1-OF4) will not link. |
| - | - | ON | Clamps (OF1-OF4) will link. |
| CF2 Clamp synchronize setting with clamp block setting(OF5-OF8) | The [The divisions of clamp(OFB.)] is validated when set to [2]. (For details, see the timing chart.) | | |
| | - | OF | Clamps (OF5-OF8) will not link. |
| - | - | ON | Clamps (OF5-OF8) will link. |
| F4BN Setting for number of valid clamp blocks | - | 1 ~ 4 | Setting is effective when OFB=[4]. Following blocks are used depends on the setting. 1:Block1, 2:Block1+2, 3:Block1+2+3, 4:Block1+2+3+4. (Block1=OF1+OF2, Block2=OF3+OF4, Block3=OF5+OF6, Block4=OF7+OF8) |

<Continuation of [Clamp]>

| Function | Unit | Setting range | Specification |
|--|--|---------------|---|
| F4SN Setting for number of block when block step is used | - | 1 ~ 4 | When set the OFB=[4], the clamp blocks of this value executes step movement. 1:Block1, 2:Block1+2, 3:Block1+2+3, 4:Block1+2+3+4 (Block1=OF1,OF2 Block2=OF3,OF4 Block3=OF5,OF6 Block4=OF7,OF8). |
| AF2 Selection of pneumatic pressure two-step clamp | The pneumatic presser two-step clamp is set. | | |
| | - | OF | Use the normal clamp. |
| OPR Prohibition of sewing data reading when clamp is raised | Reading the sewing data is prohibited by the state of the clamp. | | |
| | - | OF | sewing data can be read regardless of the state of clamp. |
| OST Prohibition of operation (sewing, JOG) when clamp is raised | Prohibition of operation (sewing, JOG) when clamp is raised | | |
| | - | OF | Operation (sewing, JOG) is prohibited when clamp is raised. |
| CHK Cassette jig function ON/OFF | Change the cassette jig function effect. | | |
| | - | OF | Cassette jig function is invalid. |
| CSN Cassette jig sensor ON/OFF | Change the cassette jig sensor effect. | | |
| | - | OF | Cassette jig sensor is invalid. |
| CSY Cassette jig sensor ON/OFF during sewing | Change the cassette jig sensor effect. (During sewing) | | |
| | - | OF | Cassette jig sensor is invalid during sewing. When the cassette jig sensor is not detected during sewing, the machine is not stopped automatic. |
| 1ST Do not use | Change the cassette jig sensor effect. (During sewing) | | |
| | - | ON | Cassette jig sensor is valid during sewing. When the cassette jig sensor is not detected during sewing, the machine is stopped automatic. |
| 1ST Do not use | ×100 ms | 0 ~ 100 | Do not use |

4.Area limit

(* When the value of the sewing area limit is changed or the limit setting is deactivated, note the collision and take care safely.
Also when using it outside the range where the mechanism can be operated, it can not assume the responsibility for all problems caused by it.)

| Function | Unit | Setting range | Specification |
|--|--------------------------------------|---------------|---|
| ALC Area limit cancel ON/OFF | Change the sewing area limit effect. | | |
| | - | OF | The stitching area limit is validated. (XL,XR,YU,YD setting is reflected) |
| XL [X axis left side] area limit setting | ×0.1 mm | 1 ~ 65535 | The stitching area limit is invalidated. (The stitching area limit is canceled.) Please use this setting with attention. |
| | | | ON |
| XR [X axis right side] area limit setting | ×0.1 mm | 1 ~ 65535 | The numerical value of the X motor right side area limit can be setting in the software. The default setting for the X motor right side area limit differs according to the model. Do not reduce this value much. Error occurs. |
| YU [Y axis rear side] area limit setting | ×0.1 mm | 1 ~ 65535 | The numerical value of the Y motor rear side area limit can be setting in the software. The default setting for the Y motor rear side area limit differs according to the model. Do not reduce this value much. Error occurs. |
| YD [Y axis front side] area limit setting | ×0.1 mm | 1 ~ 65535 | The numerical value of the Y motor front side area limit can be setting in the software. The default setting for the Y motor front side area limit differs according to the model. Do not reduce this value much. Error occurs. |

5. Needle position

| Function | Unit | Setting range | Specification |
|---|------|---------------|---|
| RU Reverse needle lifting operation after thread trimming function | - | OF ON | Sets reverse needle lifting operation after thread trimming function. The reverse needle lifting after thread trimming is invalidated. The reverse needle lifting operation after thread trimming is validated. Reverse angle is set by [S8] setting. |
| R8 Reverse run angle setting | deg. | 0 ~ 150 | The reverse run angle from the UP position after thread trimming can be set when the reverse run needle lifting [RU] is ON. |
| U8 Needle UP position coasting angle | deg. | 0 ~ 180 | The coasting angle at the needle UP position can be set. Caution. The needle bar is collide to the presser foot when the SET VALUE is high. |
| D8 Needle down position stop angle | deg. | 0 ~ 180 | The coasting angle at the needle down position can be set. |
| NUS On/off of sewing prohibition when needle is not up position | - | OF ON | Sets on/off of start sewing when needle is not up position. When needle is not up position, needle is moved to up position automatically and sewing is started. When needle is not up position, sewing is not started. |
| PL Sewing machine shaft/motor shaft speed setting selection. | - | OF ON | Sewing machine shaft/motor shaft speed setting selection. (*1) It operates in the diameter of sewing machine pulley and the motor pulley automatically set. It operates at the pulley diameter which was set by the [MR]/[SR] function. |
| MR Motor pulley diameter | mm | 0 ~ 254 | Set the diameter of motor pulley. (*1) |
| SR Sewing machine pulley diameter | mm | 0 ~ 254 | Set the diameter of sewing machine pulley. (*1) |
| UP1 Angle setting from turning off edge | deg. | 0 ~ 99 | Turning on angle of the UP output is set. (Additional angle from turning off edge) (*2) |
| UP2 Angle setting from turning on edge | deg. | 0 ~ 99 | Turning on angle of the UP output is set. (Additional angle from turning on edge) (*2) |

(*1) : Only when "XL-G554-20Y" is used for the main axis motor, it is valid.

(*2) : Only when "XL-K756-20" is used for the main axis motor, it is valid.

6.Thread breaking sensor

| Function | Unit | Setting range | Specification |
|--|---|---------------------|---|
| S1 Needle thread breaking sensor ON/OFF | Sets Valid/invalid of the needle thread breaking sensor. | | |
| | - | OF | The needle thread breaking sensor is ineffective |
| | | ON | The needle thread breaking sensor is effective |
| S2 The number of ignore stitches at the beginning of sewing. | stitches | 0 ~ 15 | The number of ignore stitches at the beginning of sewing is set. |
| S3 Invalid stitches of the stitch in progress sensor | stitches | 0 ~ 99 | Sets the number of valid stitches which is detected by thread breaking sensor |
| B Rotation speed to disregard thread breaking sensor | rpm | Maximum speed range | Rotation speed to disregard thread breaking sensor can be set. When the machine rotate below this setting, thread breaking sensor becomes invalid. Set value of rotation speed in consideration of speed variation. |
| TST Sets ON/OFF of thread trimming at needle thread breaking detection. | Valid/invalid of the thread trimming is switched, when the needle thread breaking sensor is detected. | | |
| | - | OF | The thread trimming when the needle thread breaking sensor detection is invalidated. |
| | | ON | The thread trimming when the needle thread breaking sensor detection is validated. |

7.Home position

| Function | Unit | Setting range | Specification |
|---|---|---------------|---|
| HPM Home return method after HALT | Home return method after HALT position is set. | | |
| | - | -- | Home return is executed when the home reset icon is turned ON. |
| | | JS | When the home reset icon is turned ON at the HALT position, the machine will automatically be moved like as JOG [-] icon operation. |
| | | JE | When the home reset icon is turned ON at the HALT position, the machine will automatically be moved like as JOG [+] icon operation. |
| | | JC | When the home reset icon is turned ON at the HALT position, home returning will automatically be executed. *If the position is at the [center] or [in the first half], the machine return to home like as [JS].. *If the position is [in the latter half], the machine return to home like as [JE]. |
| HPC Selection of home returning operation after power on | Sets valid/invalid of the home returning operation after power on. | | |
| | - | OF | The home returning operation is executed automatically when the power is turned on. |
| | | ON | Automatic home returning operation is prohibited at power supply on. |
| HPF Prohibition of automatic home returning when clamp is raised | Sets prohibition of home returning when the clamp is raised. | | |
| | - | OF | Home return is executed regardless of state of the clamp. |
| | | ON | Home returning is prohibited when the clamp is raised. |
| HPK Home return icon setting | The home returning icon operation is selected. | | |
| | - | -- | The home return operation is executed when the home reset icon is turned ON once. |
| | | 2 | The home returning operation is executed when the home reset icon is turned ON twice in succession. If the home reset icon is turned ON only once, the home returning operation will not be executed. |
| | | 2L | The power of the stepping motor is turned OFF (the XY table can be moved by hands) when the home reset icon is turned ON once, and when turned ON the second time, the home returning operation is executed. |
| | | NO | The home returning operation by the home reset icon is prohibited. |
| 2HS Setting for stop method at Second home position | Action at a time when the machine reads second home position is selected. | | |
| | - | ST | When the machine reads second home position, machine is stopped. |
| | | SW | When the machine reads second home position, machine is stopped and clamp goes up. |
| | | NS | The sewing machine does not stop on the second home position.. |

<Continuation of [Home position]>

| | | | |
|---|--|-----------|---|
| SHX Do not use | Do not use | | |
| | - | OF | |
| | | ON | |
| SHY Do not use | Do not use | | |
| | - | OF | |
| | | ON | |
| HPS Setting for the home returning operation when the clamp rises at power on. | Sets the home returning operation when the clamp rises at power on. | | |
| | - | OF | Home returning operation is executed regardless of clamp state at power on. |
| | | ON | Home returning operation is prohibited when the clamp is up at power on. |
| NNU Home positioning prohibition when needle is not the UP position | Home return prohibition when needle is not the UP position | | |
| | - | OF | When needle is deviated from the up position, the it is automatically moved to up position and home positioning is executed, |
| | | ON | Home return is disabled when needle is not the UP position. |
| SHP Home returning method since the second time returning | Sets home returning method since the second time returning | | |
| | - | OF | Does not use home returning sensor for XY stepping motor |
| | | ON | Uses home returning sensor for XY stepping motor |
| NUK Setting ON/OFF for display of needle up and X ICON at M-001 message | Sets for display of needle up and X ICON at M-001 message, when invalid of the home positioning(NNU) function is ON and needle is not UP position. If NNU function is [OF], this function is invalid. | | |
| | - | OF | Enable display of needle up and X ICON at M-001 message, when NNU function is ON. |
| | | ON | Disable display of needle up and X ICON at M-001 message, when NNU function is ON. |
| NUM Invalidity setting of detection that needle is not up position after turning power on. | Sets of detecting whether needle is upper position or not after turning the power on. | | |
| | - | OF | It is detected whether needle is upper position or not, when first returning home position or first sewing after turning the power on. |
| | | ON | It is not detected whether needle is upper position or not, when first returning home position or first sewing after turning the power on. This detection is valid when (RU)=ON and (NNU)=OFF. Caution that it is likely to sew the sewn product or the clamp frame, when sewing is started. Caution that main axis rotates, when (HPC)=OF. |
| HPL Setting of limit value for home position supplementation. | ×0.1 mm | 0 ~ 10000 | Set the limit value of supplementation from original XY axis home position. |

8.Halt

| Function | Unit | Setting range | Specification |
|---|------|---------------|--|
| STF Stop position setting when halt switch is pressed while non stitch feed operation | - | CP | When the HALT switch is turned ON, non-stitching feed will be executed until the breakpoint (the position where non-stitching feed direction changes). |
| | | ST | When the HALT switch is turned ON, the machine will stop at that position. |
| STN Needle position when halt switch is turned on. | - | DN | When the HALT switch is on, the needle will stop at the DOWN position. |
| | | UP | When the HALT switch is on, the needle will stop at the UP position. |
| STS The state of each output when the HALT switch is turned on | - | AL | All outputs will be held (ON is maintained). (exclude wiper, trimmer, thread release) |
| | | FU | Keep the output state of the clamp relation.(keep output excluding general purpose, wiper, trimmer and tension release) |
| | | OF | Release output for the clamp relation, general purpose, wiper, trimmer, tension release. |
| ST2 HALT switch two-press operation (stop at down position) | - | UT | When the HALT switch is turned on again, the needle will stop at the up position after thread trimming. |
| | | UP | When the HALT switch is turned on again, the needle will stop at the up position without thread trimming. (when set (STN.)=[DN]) |
| | | ST | The needle will stay at the down position even if the HALT switch is turned ON again. |
| STP Operation of power supply after HALT switch is turned on and off. <TURN OFF THE POWER> | - | -- | Restarting is possible after the sewing machine is stopped by the foot switch. |
| | | PD | Same behavior as emergency stop switch. please turn off the power and restart again. |
| STD Clamp condition during halt state by the STOP code | - | FU | Clamp goes up after machine is stop |
| | | FD | Keeps clamp condition after machine is stop |
| STL Prevention of two drops at the same point after HALT | - | OF | After needle down position stop, machine restarts from the stop position (needle goes down at the same position twice) |
| | | ON | After needle down position stop, machine restarts from next stitch point (needle does not go down at the stop position) |

9.Counter

| Function | Unit | Setting range | Specification |
|--|----------|---------------|--|
| CUP Sets function of UP counter | - | -- | Up counter is not executed |
| | | ED | Up counter decreases every 1 sewing pattern is executed |
| | | ST | Up counter decreases every N stitches (N is set by [CND] setting) |
| | | CY | Do not use |
| CDN Sets function of DOWN counter | - | -- | Down counter is not executed |
| | | ED | Down counter increases every 1 sewing pattern is executed |
| | | ST | Down counter increases every N stitches (N is set by [CNU] setting) |
| | | CY | Do not use |
| CNU Setting number of stitches of each 1 count for UP counter | stitches | 5 ~ 1000 | Setting of the number of stitches when "ST" of the CUP setting is selected |
| CND Setting number of stitches of each 1 count for DOWN counter | stitches | 5 ~ 1000 | Setting of the number of stitches when "ST" of the CDN setting is selected |

<Continuation of [Counter]>

| Function | Unit | Setting range | Specification |
|---|---|---------------|---|
| UCM Method of clearing (UP) counter setting value | Up counter clear method at the pattern data change is selected | | |
| | - | -- | The UP counter value and current value are both not changed. |
| | | RE | If the [B Series data] is read in the When pattern data is changed, up counter SET VALUE is change to the number which is contained in the pattern data. |
| | | IT | When pattern data is changed, up counter SET VALUE is not changed and up counter current value is set to 0. |
| DCM Method of clearing (DOWN) counter setting value | Down counter clear method at the pattern data change is selected | | |
| | - | -- | The DOWN counter value and current value are both not changed. |
| | | RE | When pattern data is changed, down counter SET VALUE is change to the number which is contained in the pattern data. |
| | | IT | When pattern data is changed, down counter SET VALUE is not changed and down counter current value is changed to SET VALUE. |
| PCM Valid/invalid for initialization of UP/DOWN counter value at power on. | Sets counter clear method at power supply on. | | |
| | - | -- | The counter is not initialized. |
| | | IT | Initializes (The UP counter current value is set to 0, and the DN counter current value is set to counter setting.) |
| CN stitch number pre-check function | Selects stitch number check function at the beginning of sewing.. | | |
| | - | OF | The machine does not check next stitch number at the beginning of sewing. |
| UCC Prohibition of UP counter current value correction | Sets prohibition of UP counter current value | | |
| | - | OF | The current value of the UP counter can be modified. |
| DCC Prohibition of DOWN counter current value correction | Sets prohibition of DOWN counter current value | | |
| | - | OF | The current value of the DOWN counter can be modified. |
| USC Restart sewing ON/OFF after count up completion | Setting for restart sewing by UP counter completion | | |
| | - | OF | Even when the count value of the UP counter reaches the set value, the next sewing machine operation can be continued. |
| DSC Restart sewing ON/OFF after count down completion | Setting for restart sewing by DOWN counter completion | | |
| | - | OF | Even when the count value of the DOWN counter reaches the set value, the next sewing machine operation can be continued. |
| NC1 ON/OFF of stitch number counter function 1 | Sets valid/invalid of stitch number counter 1 | | |
| | - | OF | Invalidates stitch number counter 1 |
| CW1 Setting for warning stitch number of counter 1 | 100000 stitches | 0 ~ 9999 | Validates stitch number counter 1. If the value of the stitch number counter corresponded to the setting value, the warning message is displayed after turning the next power on. |
| | | | Warning stitch number of the counter 1 can be set. |
| NC2 ON/OFF of stitch number counter function 2 | Sets valid/invalid of stitch number counter 2 | | |
| | - | OF | Invalidates stitch number counter 2 |
| CW2 Setting for warning stitch number of counter 2 | 100000 stitches | 0 ~ 9999 | Validates stitch number counter 2. If the value of the stitch number counter corresponded to the setting value, the warning message is displayed after turning the next power on. |
| | | | Warning stitch number of the counter 2 can be set. |

10.Brake

| Function | Unit | Setting range | Specification |
|-------------------------------------|--|---------------|--|
| WBK Weak brakes setting | Sets effective/ineffective of the weakening brake. | | |
| | - | OF | The weak brakes is set ineffective |
| | | ON | The weak brakes is set effective |
| BKM Weak brake type setting | Sets type of weak brake during sewing machine is stopping. | | |
| | - | E | Brakes that can be rotated by hand. |
| | | H | Brakes that cannot be rotated by hand. |
| BKT Main axis brake time setting | ms | 0 ~ 1000 | Sets main axis brake time |
| WBG Weak brake gain setting. | Sets gain of weak brake. | | |
| | - | OF | The gain of weak brake is set high. The reaction of brake is early. But the excitation sound is noisy. |
| | | ON | The gain of weak brake is set low. The excitation sound is quiet. But the reaction of brake is late. |

11.Presser foot

| Function | Unit | Setting range | Specification |
|---|---|------------------------|---|
| PLP Setting for stroke of presser foot | ×0.1 mm | depends on the machine | Presser foot up & down standard value (only even number can be set) |
| ZU8 Start angle for presser foot going up (based on needle up position) | deg. | 0 ~ 360 | Sets start angle for the presser foot up. Angle is based on needle up position. |
| ZD8 Start angle for the presser foot down (based on needle up position) | deg. | 0 ~ 360 | Sets start angle for the presser foot down. Angle is based on needle up position. |
| ZTM Synchronization of presser foot data in the teaching mode | Sets synchronization of presser foot data in the teaching mode | | |
| | - | OF | Does not Synchronize presser foot data in the teaching mode |
| | | ON | Synchronizes presser foot data in the teaching mode |
| DPA Period between end of PF down and start needle motion axis (SEWING) | - | 1 ~ 9999 | Period between end of PF down motion and start needle motion axis (Automatic sewing) |
| DPX Period between end of presser foot motion and start XY axis (JOG) | - | 1 ~ 9999 | Sets period time between end of presser foot motion and start XY axis (JOG) |
| DZX Period between end of PF up and start return to HP.(HP) | - | 1 ~ 9999 | Sets period time between end of PF home positioning and start XY axis home positioning (HP) |
| PFC Sets ON/OFF of prohibition of presser foot up in non stitch feed. | Sets ON/OFF of prohibition of presser foot up in non stitch feed. | | |
| | - | OF | Presser foot up in non stitch feed. |
| | | ON | Presser foot never up in non stitch feed. |
| PFH Sets ON/OFF of prohibition of presser foot inversion in non home position. | Sets ON/OFF of presser foot inversion in non home position. | | |
| | - | OF | Presser foot inverts regardless of home position. |
| | | ON | Presser foot inverts in home position only. |
| UPA Period between end of PF up and start XY axis (SEWING) | - | 0 ~ 9999 | Period between end of PF up motion and start XY axis (Automatic sewing) |
| EPF Sets ON/OFF of PF control by stepping motor. | Sets ON/OFF of PF control by stepping motor. | | |
| | - | OF | PF is controlled by stepping motor. |
| | | ON | PF is not controlled by stepping motor. Functions of [Setting for material thickness],[Input the material step level],[Modify the material step level] are invalid. |
| NZH Sets ON/OFF of using PF sensor.(At setting EPF=ON) | Sets ON/OFF of using PF sensor.(At setting EPF=ON) | | |
| | - | OF | PF sensor is used. |
| | | ON | PF sensor is not used. |

12. Bobbin winding

| Function | Unit | Setting range | Specification |
|---|----------------------------------|---------------|---|
| W Bobbin winding speed setting | rpm | LOW ~ HIGH | Sets the speed of the sewing machine during bobbin winding. |
| WSM Bobbin winding operation setting | Sets the operation of the winder | | |
| | - | NO | While the operation signal SRT is turned [ON], the sewing machine rotates. When the signal is turned [OFF], the sewing machine stops. |
| | | AL | When start signal SRT is turned ON, the sewing machine continues its operation. Furthermore, when the start signal SRT is ON, machine is stopped. |
| | | T | When the operation signal SRT is turned [ON], the sewing machine continues to run within the time which is set in (WT.) function. |
| WT Bobbin winding operation time | s | 1 ~ 500 | The bobbin winding operation time (timer) can be set. (effective when WSM =[T]) |

13. Feed method

| Function | Unit | Setting range | Specification |
|--|--|---------------|---|
| WET Clamp weight selection | Sets the feeding method corresponding to the clamp weight. If the unusual clamp is adapted, please set the value corresponding to the clamp weight. | | |
| | - | L | For standard delivery clamp [L] |
| | | M | Heavy weight setting [M] |
| | | H | Heavy weight setting [H] |
| WEL Setting value when clamp [L] is selected | % | 1 ~ 100 | SET value is applied when CLAMP WEIGHT SELECTION (WET.)=[L]. It limits maximum sewing speed of each stitch length. |
| WEM Setting value when clamp [M] is selected | % | 1 ~ 100 | SET value is applied when CLAMP WEIGHT SELECTION (WET.)=[M]. It limits maximum sewing speed of each stitch length. |
| WEH Setting value when clamp [H] is selected | % | 1 ~ 100 | SET value is applied when CLAMP WEIGHT SELECTION (WET.)=[H]. It limits maximum sewing speed of each stitch length. |
| THI Cloth thickness selection | Table feed timing corresponding to the sewing material thickness can be selected. Set value according to the sewing material thickness. The number in the () indicates the approximate thickness. | | |
| | - | L | Standard setting [L]------(0-3mm) |
| | | M | Thick material setting [M]---(3-6mm) |
| | | H | Thick material setting [H]---(6-8mm) |
| TL Setting value when cloth thickness [L] is selected | % | 1 ~ 100 | SET value is applied when material THICKNESS SELECTION(THI.)=[L]. It limits maximum sewing speed of each stitch length. The factory setting is for approx (0 to 3mm). |
| TM Setting value when cloth thickness [M] is selected | % | 1 ~ 100 | SET value is applied when material THICKNESS SELECTION(THI.)=[M]. It limits maximum sewing speed of each stitch length. The factory setting is for approx (3 to 6mm). |
| TH Setting value when cloth thickness [H] is selected | % | 1 ~ 100 | SET value is applied when material THICKNESS SELECTION(THI.)=[H]. It limits maximum sewing speed of each stitch length. The factory setting is for approx (6 to 8mm). |
| FED Feed setting | The table feeding method is selected. | | |
| | - | ID | Table is stopped when needle point is under sewing material. |
| | | S | Table is fed continuously even needle point is under sewing material. (There is a risk that needle may broken depends on the sewing material) |
| FEM Setting for non stitch feed | Non stitch feed tracks can be selected. | | |
| | - | K | Non stitch feed which traces the inputted tracks (slower than [S] setting) |
| | | S | Non stitch feed is moved at high speed. table moves diagonally (45 degree) at first, then moves either X or Y direction |
| FSL Non stitch feed speed setting for long distance | - | 0 ~ 9 | Non stitch feed speed for long distance can be set from [0 (slow)] to [9 (fast)]. |
| FSS Non stitch feed speed setting for short distance | - | 0 ~ 9 | Non stitch feed speed for short distance can be set from [0 (slow)] to [9 (fast)]. |
| TSL Teaching speed setting for long distance | - | 0 ~ 9 | Teaching speed for long distance can be set from [0 (slow)] to [9 (fast)]. |

<Continuation of [Feed method]>

| | | | |
|--|--|---------|---|
| TSS Teaching speed setting for short distance | - | 0 ~ 9 | Teaching speed for short distance can be set from [0 (slow)] to [9 (fast)]. |
| STQ Power setting of XY stepping motor (gain) | - | 1 ~ 30 | Sets gain for XY stepping motor. [1(weak)] - [30(strong)] |
| FFS Setting of feedforward 100% for XY stepping motor | Setting feedforward of XY stepping motor control 100% or not | | |
| | - | OF | Sets feedforward of XY stepping motor control not 100% |
| | | ON | Sets feedforward of XY stepping motor control 100% |
| ZSL ON/OFF of main axis speed limit by presser foot motion | ON/OFF of main axis speed limit by presser foot motion | | |
| | - | OF | Invalidates main axis speed limit by presser foot motion |
| | | ON | Validates main axis speed limit by presser foot motion |
| TPH Amount of maximum movement of the arrow input in the teaching mode. | ×0.1 mm | 1 ~ 200 | Amount of maximum movement of the arrow input in the teaching mode. |
| TPY Sets ON/OFF of the amount of maximum movement of the arrow input in the teaching mode. | Sets ON/OFF of the amount of maximum movement of the arrow input in the teaching mode. | | |
| | - | OF | The value of the setting TPH is invalid. |
| | | ON | The value of the setting TPH is valid. |
| LH Setting of length of continuous feed sew in maximum | ×0.1 mm | 1 ~ 200 | The maximum stitch range can be specified for continuous feed sew. |
| FSH Sets ON/OFF for max speed of continuous feeding becomes HIGH setting. | Sets ON/OFF for maximum sewing speed of continuous feeding become the setting HIGH. This setting is validated when the FED setting is S. | | |
| | - | OF | Continuous feeding max speed not become HIGH set value. |
| | | ON | Continuous feeding max speed become HIGH set value. |
| FKT Sets ON/OFF of diagonal feed of the XY table | Sets ON/OFF of method of feed, diagonal or not. | | |
| | - | OF | Feed in the direction of 45degree. |
| | | ON | Feed in the direction of diagonal. |

14.Speed

| Function | Unit | Setting range | Specification |
|------------------------------------|------|---------------------|---|
| HIGH High speed | rpm | Maximum speed range | The speed of HIGH speed code can be set. (*1) |
| LOW Low speed | rpm | Minimum speed range | The speed of LOW speed code can be set. |
| MD1 Middle speed 1 [MD1] | rpm | Maximum speed range | Speed for MD1 code (medium speed 1) can be set. |
| MD2 Middle speed 2 [MD2] | rpm | Maximum speed range | Speed for MD2 code (medium speed 2) can be set. |

(*1): The sewing speed might be limited according to the pitch, the setting of the thickness of the cloth, and the weight setting. The speed limit has priority when speed limit is lower than set value(HIGH, MD1, MD2).

15.Thread trimming/Thread release

| Function | Unit | Setting range | Specification |
|--|--|---------------------|---|
| TRM Thread trimming ON/OFF | Sets valid/invalid of the thread trimming. | | |
| | - | OF | The thread trimming is invalidated. |
| | | ON | The thread trimming is validated. |
| LTM Setting for thread trimming output (T) timing. | Thread trimming output (T) timing can be set. | | |
| | - | T1 | Thread trimming is begun at TRS setting (degree) from needle down position, and is ended at TRE setting (time) from needle up position. Please refer to technical manual for details.) |
| | | T2 | Thread trimming is begun at TRS setting (degree) from needle down position, and is ended at TRE setting (degree). Please refer to technical manual for details.) |
| | | T3 | Thread trimming is begun at TRS setting (degree) from needle down position, and is ended at TRE setting (time). Please refer to technical manual for details.) |
| | | T4 | Thread trimming is begun at TRS setting (time) from needle down position, and is ended at TRE setting (time) from needle down position. Please refer to technical manual for details.) |
| | | T5 | Thread tension release is begun at TRS setting (time) from needle up position, and is ended at TRE setting (time). Please refer to technical manual for details.) |
| TRS Thread trimming output start time/angle | ms/deg. | 0 ~ 998 | The output start time of the thread trimming output(T) can be set. Refer to technical manual for details. |
| TRE Thread trimming output time/angle | ms/deg. | 0 ~ 998 | The output end time of the thread trimming output(T) can be set. Refer to technical manual for details. |
| T Thread trimming speed | rpm | Minimum speed range | Thread trimming speed between needle down position and needle up position can be set. Refer to timing chart for details. |
| ETC Thread trimming ON/OFF at needle up icon operation | Sets the ON/OFF the trimming by the needle up icon at the halt state. | | |
| | - | OF | Thread trimming is executed (effective when STN = DN) |
| | | ON | Thread trimming is not executed (effective when STN = DN) |
| LSP Sets ON/OFF of thread tension release output at presser foot up. | Sets ON/OFF of thread tension release output at presser foot up. | | |
| | - | OF | Thread tension release output is not continued. |
| | | ON | Thread tension release output is continued. |
| LLM Setting for thread tension release output (L) timing | Thread tension release output (L) timing can be set. (Please refer to timing chart for details.) | | |
| | - | L1 | Thread tension release is begun at LRS setting (degree) from needle down position, and is ended at LRE setting (time) from needle up position. Please refer to technical manual for details.) |
| | | L2 | Thread tension release is begun at LRS setting (degree) from needle down position, and is ended at LRE setting (degree). Please refer to technical manual for details.) |
| | | L3 | Thread tension release is begun at LRS setting (degree) from needle down position, and is ended at LRE setting (time). Please refer to technical manual for details.) |
| | | L4 | Thread tension release is begun at LRS setting (time) from needle down position, and is ended at LRE setting (time) from needle down position. Please refer to technical manual for details.) |
| | | L5 | Thread tension release is begun at LRS setting (time) from needle up position, and is ended at LRE setting (time). Please refer to technical manual for details.) |
| LRS Thread release output start time/angle | ms/deg. | 0 ~ 998 | Start time/angle of thread release output can be set. Please refer to technical manual for details. |
| LRE Thread release output time/angle | ms/deg. | 0 ~ 998 | End time/angle of thread release output can be set. Please refer to technical manual for details.) |
| LP Setting for tension release outputs time length at presser foot rise | s | 0 ~ 10000 | Outputs tension release signal when the presser foot goes up |
| LFP Setting of thread release output at presser foot up in non stitch feed. | Sets ON/OFF of prohibition of thread tension release output at presser foot up in non stitch feed (include JOG). | | |
| | - | OF | Thread tension release output is done at presser foot up. |
| | | ON | Thread tension release output is not done at presser foot up. |

16.Step

| Function | Unit | Setting range | Specification |
|--|---|---------------|---|
| STO Step sequence ON/OFF | Sets ON/OFF step sequence | | |
| | - | OF | Sets step sequence OFF |
| | | ON | Sets step sequence ON |
| SUU Execution number of lines of one main loop in step sequence. | lines | 1 ~ 10 | Sets execution number of lines of one main loop in step sequence. |
| SP1 AND priority execution ON/OFF for step sequence | Sets AND priority execution ON/OFF for step sequence | | |
| | - | OF | Executes in order of the input. |
| | | ON | Executed with giving priority to AND |
| SOA Sets ON/OFF of reversing function of customization at step sequence output. | It is used in step sequence output of reversing function that has been set in output customization. | | |
| | - | OF | Disable reversing function that has been set in output customization. |
| | | ON | Enable reversing function that has been set in output customization. |

17.Jog

| Function | Unit | Setting range | Specification |
|---|---|---------------|--|
| JGM JOG icon function setting | Sets function of the JOG [+/-] icons. | | |
| | - | -- | The XY table moves according to the pattern data while the JOG icon is ON, and stops when turned OFF. |
| | | AL | The JOG [+] icon is turned ON : The XY table moves, automatically proceeds to the end point. The JOG [-] icon is turned ON : The XY table moves, automatically returns to the start point. During movement, the operation will stop if either of the JOG [+/-] icons is turned ON again. |
| | | HA | The JOG [+] or [-] icon is turned ON until XY table reached at high speed : The XY table will automatically move to the end point or start point. If the icon is turned OFF before the high speed is reached, the operation will stop immediately. During movement, the operation will stop if either of the JOG [+/-] icons is turned ON again. |
| UJC Valid setting of JOG icon excluding needle UP position | The operation (valid/invalid) of the JOG icon excluding a needle up position can be selected. | | |
| | - | OF | The JOG operation is possible only when the needle is at UP stop position. |
| | | ON | The JOG operation is possible regardless needle position. Be aware that the JOG operation becomes valid even when the needle is in the fabric. |
| JGS Action of stop code between continuous JOG. | Action of stop code between continuous JOG can be selected. | | |
| | - | OF | Between continuous JOG, table keeps moving even the needle up stop code (USTP) or the needle down stop code (DSTP) is appeared. |
| | | ON | Between continuous JOG moving, when the needle up stop code (USTP) or the needle down stop code (DSTP) is appeared, table is stopped. |
| SJC Sets ON/OFF of the smooth JOG | Sets ON/OFF of the smooth JOG | | |
| | - | OF | The smooth JOG is invalid. |
| | | ON | The smooth JOG is valid. |
| JSL JOG speed setting for long distance | - | 0 ~ 9 | JOG speed for long distance can be set from [0 (slow)] to [9 (fast)]. |
| JSS JOG speed setting for short distance | - | 0 ~ 9 | JOG speed for short distance can be set from [0 (slow)] to [9 (fast)]. |

18.Feed angle

| Function | Unit | Setting range | Specification |
|---|---|----------------------------|---|
| S8 Setting for feed start angle of clamp | deg. | 0 ~ E8 setting value | Sets the timing to start movement of the clamp during sewing machine rotation. The setting indicates the angle from the down position. This setting is validated when the FED setting is ID. |
| E8 Setting for feed end angle of clamp | deg. | S8 setting value ~ 356 | Sets the timing to end movement of the clamp during sewing machine rotation. The setting indicates the angle from the down position. This setting is validated when the FED setting is ID, IT. |
| S8C Sets ON/OFF of the delay supplement control of the feed start angle. | Sets ON/OFF of the supplement control of the delay proportional at speed for the feed start angle | | |
| | - | OF | The delay supplement control of the feed start angle(S8) is valid. |
| E8C Sets ON/OFF of the delay supplement control of the feed end angle. | Sets ON/OFF of the supplement control of the delay proportional at speed for the feed end angle | | |
| | - | OF | The delay supplement control of the feed end angle(E8) is valid. |
| S8S Sets ON/OFF of the separate feed angle control for XY axis. | Sets ON/OFF of the separate feed angle control for XY axis | | |
| | - | OF | The separate feed angle for XY axis is invalid |
| | - | ON | The separate feed angle for XY axis is valid |
| | | | |
| XS8 Setting for feed start angle of X axis table | deg. | 0 ~ XE8 setting value | Sets the timing to start movement (S8) of X axis table during sewing machine rotation. The setting indicates the angle from the down position. This setting is validated when the FED setting is ID. |
| XE8 Setting for feed end angle of X axis table. | deg. | XS8 setting value ~ 356 | Sets the timing to end movement (E8) of X axis table during sewing machine rotation. The setting indicates the angle from the down position. This setting is validated when the FED setting is ID. |
| XT8 Setting for feed start supplement angle of X axis table | deg. | 0 ~ XE8 setting value | Sets the supplement timing to start movement (S8) of X axis table during sewing machine rotation at high speed. The setting indicates the angle from the down position. This setting is validated when the FED setting is ID. |
| YS8 Setting for feed start angle of Y axis table | deg. | 0 ~ YE8 setting value | Sets the timing to start movement (S8) of Y axis table during sewing machine rotation. The setting indicates the angle from the down position. This setting is validated when the FED setting is ID. |
| YE8 Setting for feed end angle of Y axis table | deg. | YS8 setting value ~ 356 | Sets the timing to end movement (E8) of Y axis table during sewing machine rotation. The setting indicates the angle from the down position. This setting is validated when the FED setting is ID. |
| YT8 Setting for feed start supplement angle of Y axis table | deg. | 0 ~ YE8 setting value | Sets the supplement timing to start movement (S8) of Y axis table during sewing machine rotation at high speed. The setting indicates the angle from the down position. This setting is validated when the FED setting is ID. |
| SEL Do not use | Do not use | | |
| | - | OF | |
| | | ON | |

19.Other

| Function | Unit | Setting range | Specification |
|---|--|--|--|
| SC1 Valid/invalid serial communication 1 <TURN OFF THE POWER> | Validates/invalidates serial communication 1. Please turn off the power after the setting change and restart again. | | |
| | - | OF | Invalidates serial communication 1 |
| | | ON | Validates serial communication 1 |
| BR1 Setting for baud rate for serial communication 1 <TURN OFF THE POWER> | Sets baud rate for serial communication 1. Please turn off the power after the setting change and restart again. | | |
| | - | 96 | Sets baud rate 9600bps |
| | | 384 | Sets baud rate 38.4kbps |
| | | 576 | Sets baud rate 57.6kbps |
| | | 1152 | Sets baud rate 115.2kbps |
| | OF | Set baud rate to the value which is set by BM1 | |
| BM1 Arbitrary setting for serial communication 1 <TURN OFF THE POWER> | ×100 bps | 96 ~ 2560 | Sets arbitrary board rate of serial communication 1 Please turn off the power after the setting change and restart again. |
| SC2 Valid/invalid serial communication 2 <TURN OFF THE POWER> | Valid/invalid serial communication 2. Please turn off the power after the setting change and restart again. | | |
| | - | OF | Invalidates serial communication 2 |
| | | ON | Validates serial communication 2 |
| BR2 Setting of baud rate for serial communication 2 <TURN OFF THE POWER> | Sets baud rate for serial communication 2. Please turn off the power after the setting change and restart again. | | |
| | - | 96 | Sets baud rate 9600bps |
| | | 384 | Sets baud rate 38.4kbps |
| | | 576 | Sets baud rate 57.6kbps |
| | | 1152 | Sets baud rate 115.2kbps |
| | OF | Set baud rate to the value which is set by BM2 | |
| BM2 Arbitrary setting for serial communication 2 <TURN OFF THE POWER> | ×100 bps | 96 ~ 2560 | Sets arbitrary board rate of serial communication 2 Please turn off the power after the setting change and restart again. |
| MIL Milling mode ON/OFF <TURN OFF THE POWER> | Sets valid/invalid of milling function. Please turn off the power after the setting change and restart again. | | |
| | - | OF | XY table is operated with normal mode. |
| | | ON | XY table is operated with milling mode. The movement speed of XY table is changed by speed dial value on standard screen (Migration coefficient of XY table at the milling mode[MLC]). ((speed dial value+1)x(MLC Value)x0.1mm)/17ms |
| MLC Setting for migration coefficient of XY table at the milling mode. | Sets for migration coefficient of XY table at the milling mode.((speed dial value+1)x(MLC Value)x0.1mm)/17ms | | |
| | - | S | Default setting (Small) [S] |
| | | M | Middle [M] |
| | | L | Large [L] |
| BOM Setting for the control box temperature warning | Sets valid/invalid for the control box temperature warning detection. | | |
| | - | OF | Invalidates control box temperature warning detection. |
| | | ON | Validates control box temperature warning detection. |
| CDD Display of code in image setting | The method of displaying the code of the sewing data image display is set. | | |
| | - | DP | The content of the code is displayed. |
| | | CR | All the codes are displayed by "Circle". |
| | NO | The code is not displayed. | |
| RF Forward rotation angle setting | deg. | 0 ~ 150 | Sets forward rotation angle. |
| ADS Angle operation speed setting | rpm | 100 ~ 1000 | Sets angle operation speed. |
| ND1 Needle change delay 1 setting | ms | 10 ~ 9999 | Needle change delay 1 (Sets the time from end of needle up to turning on of the needle change solenoid) |
| ND2 Needle change delay 2 setting | ms | 10 ~ 9999 | Needle change delay 2 (Sets the time from needle change solenoid on to start reverse rotation) |
| ND3 Needle change delay 3 setting | ms | 10 ~ 9999 | Needle change delay 3 (Sets the time end of reverse rotation to start forward rotation) |

<Continuation of [Other]>

| | | | |
|---|---|----|---|
| THO Needle thread breaking sensor 2 ON/OFF | Sets Valid/invalid of the needle thread breaking sensor2. | | |
| | - | OF | The needle thread breaking sensor2 is ineffective |
| | | ON | The needle thread breaking sensor2 is effective (when the (VBM.) setting [ON] only) |
| GPL ON/OFF of communication error detection with operation panel | Sets communication error detection when the operation panel is not connected with the control box | | |
| | - | OF | Validates communication error detection with operation panel |
| | | ON | Invalidates communication error detection with operation panel |
| EMC ON/OFF of EMC proof setting <TURN OFF THE POWER> | Validates/Invalidates EMC proof setting. Please turn off the power after the setting change and restart again. | | |
| | - | OF | Sets OFF when the machine is operated under normal condition |
| | | ON | Sets ON when the machine is operated with EMC proof setting |

20. Pattern

| Function | Unit | Setting range | Specification |
|--|--|---------------|--|
| APC Pattern select function by external signal <TURN OFF THE POWER> | The sewing data selection method is set. Please turn off the power after the setting change and restart again. | | |
| | - | OF | Selects sewing pattern data number by using the operation panel. |
| | | ON | Select sewing pattern number by external signal. Setting range is from 800 to 863. (Input signal function P01,P02,P04,P08,P16,P32 are used) |
| POF Pattern offset selection by external signal | Offset number for pattern data number selection by using external signal. | | |
| | - | 8 | Sewing data number becomes specified number plus 800. |
| | | 6 | DO NOT USE |
| | | 4 | DO NOT USE |
| PTC Change in setting table number from the sewing data | Selects setting table change action at the pattern data change when pattern data contains setting table number information. | | |
| | - | OF | The change in the setting table number from the sewing data is unavailable. |
| | | ON | The change in the setting table number from the sewing data is available. |
| PT1 Sewing pattern data selection by serial communication 1 <TURN OFF THE POWER> | Sets effective/ineffective sewing pattern data selection by serial communication 1. Please turn off the power after the setting change and restart again. | | |
| | - | OF | Sets ineffective sewing pattern data selection by serial communication 1 |
| | | ON | Sets effective sewing pattern data selection by serial communication 1. This function is valid when (SC1)=ON. It can switch to another sewing pattern at home position only. However, when (M2H)=[HP2], it can switch to another sewing pattern at second home position. |
| PT2 Sewing pattern data selection by serial communication 2 <TURN OFF THE POWER> | Sets effective/ineffective sewing pattern data selection by serial communication 2. Please turn off the power after the setting change and restart again. | | |
| | - | OF | Sets ineffective sewing pattern data selection by serial communication 2 |
| | | ON | Sets effective sewing pattern data selection by serial communication 2. This function is valid when (SC2)=ON. It can switch to another sewing pattern at home position only. However, when (M2H)=[HP2], it can switch to another sewing pattern at second home position. |
| APT Setting of pattern selection timing by using of external signal | Chooses sewing pattern number switching timing by using external signal. | | |
| | - | OF | The pattern number is changed at the sewing end, at the beginning of sewing or at the beginning of +Jog. |
| | | ON | When a new pattern number is input, it is switched immediately. (However, only at home position) This function is valid when (SC1), (PT1) and (APC)=ON or (SC2), (PT2) and (APC)=ON. |
| HPW Setting of material thickness of pattern. | Sets valid/invalid of material thickness setting in the pattern data | | |
| | - | OF | Invalidates material thickness value in the pattern data. |
| | | ON | Validates material thickness value in the pattern data. |
| M2H Second home positioning operation with pattern data which includes second home position | Selects second home positioning operation with pattern data which includes second home position. (*1: When (SHP)=ON, it is not able to use it.) | | |
| | - | OF | When pattern data which includes second home position is read, machine does not move to second home position automatically. |
| | | ON | When pattern data which includes second home position is read, machine moves to second home position automatically. |
| | | HP2 *1 | When pattern data which includes second home position is read, machine moves to second home position automatically. The second home returning operation is executed. |

<Continuation of [Pattern]>

| | | | |
|--|--|--------------|---|
| PKY It release or not release the selected pattern data after sewing machine rotation. | Setting of whether to release the selected sewing pattern data after sewing machine rotation, when the sewing pattern data selection by serial communication is effective. | | |
| | - | OF ON | When the sewing pattern data selection by serial communication is effective, the selected sewing pattern data is not released after sewing machine rotation. When the sewing pattern data selection by serial communication is effective, the selected sewing pattern data is released after sewing machine rotation. Please select the sewing pattern data by serial communication again. This function is valid when (SC1) and (PT1) =ON or (SC2) and (PT2) =ON. |
| ASR Setting of the unit of the time that is stopped by ASRT code. | Sets the unit of the time from stop by the ASRT code during sewing machine rotation to sewing again. | | |
| | - | 1000 | The unit of the time that is stopped by the ASRT code is set to 1 sec(1000msec). |
| | | 500 | The unit of the time that is stopped by the ASRT code is set to 0.5 sec(500msec). |
| | | 200 | The unit of the time that is stopped by the ASRT code is set to 0.2 sec(200msec). |

[17] Error / Message display

1. [E-***] Error code

- *. When the error message is displayed, confirm the contents and investigate according to the following table.
- *. The machine can be restored to the normal mode by turning off the power once and turning on again.

| CODE | ERROR NAME | PROBABLE CAUSE | INSPECTION |
|-------|---|---|--|
| E-001 | Main axis overcurrent error | -Wiring to the main motor is short-circuited. -The load torque of the sewing machine is too large. | -Check the wiring for the main motor. -Check the sewing machine. |
| E-002 | Over power supply voltage error | -The power-supply voltage is too high. -The inertia of the sewing machine is too large. | -Check the power –supply voltage. -Please consult the sewing machine shop of the order. |
| E-003 | Main axis lock error | -The main motor encoder connector has not been firmly inserted. -The signal from the main motor encoder has been disconnected. -Sewing machine is locked. -Main motor is locked -Main motor connector has been firmly inserted. | -Check the insertion of the connector. -Check the encoder A/B/ phase signal by using IN/OUT setting mode. -Check the sewing machine. -Check the motor. |
| E-005 | Board temperature rise error | -The load torque of the sewing machine is too large. -The output such as solenoids is an overload. | -Check the sewing machine. -Check the output current of 24V used with the solenoid etc. Attention) Please turn on the power supply again after falling the temperature in the board. |
| E-006 | X axis a phase adsorption error | -Clamp X position is at the end of the sewing area or clamp is hit to obstacle. | -Check clamp position. |
| E-007 | Y axis a phase adsorption error | -Clamp Y position is at the end of the sewing area or clamp is hit to obstacle. | -Check clamp position. |
| E-009 | SOL substrate solenoid overcurrent error | -The solenoid connecting wires is short-circuited. -The cable of solenoid is short-circuited. -Total current of solenoid output is used over rating value. | -Check the wiring for the solenoid. -Exchange the solenoid. -Use below rating current value. |
| E-014 | SOL substrate 24v power supply error | -24V power supply is not supplied to the SOL substrate. | -Check CON-C or CON-N connection. -Exchange fuse on SOL substrate. |
| E-015 | SOL substrate air valve overcurrent error | -Output terminal and 24V terminal of CON-M is short-circuited. -There is a trouble at electromagnetic valve etc. which is connected with CON-M. -Total output current of the CON-M is over rating value. | -Check output wiring from CON-M and remove short-circuited point. -Exchange electromagnetic valve which is connected to CON-M. -Use with below the rating current value. For example, decrease number of output, change to output device with low current value, shift on timing of each output, change setting of the full wave on time to smaller or zero. |
| E-016 | CPU substrate 5V voltage detection error | -There is a trouble in the CPU substrate or the external 5V power supply is short-circuited. | -Check the encoder cable. -Exchange the CPU substrate. |
| E-017 | SOL substrate output communication error | -The solenoid communication connector has not been firmly inserted. -The solenoid communications cable has been disconnected. | -Check the wiring for the solenoid valve. -Check the wiring for the cable. |
| E-018 | SOL substrate input communication error | -The solenoid communication connector has not been firmly inserted. -The solenoid communications cable has been disconnected. | -Check the wiring for the solenoid valve. -Check the wiring for the cable. |
| E-019 | PAL back light error | -Cable for back light in the operation panel is disconnected -Back light of the operation panel is damaged or cable is disconnect. | -Check the back light connector CON7 in the operation panel and insert firmly. -Exchange operation panel. |
| E-020 | PAL communication error | -The PAL communication connector has not been firmly inserted -The PAL communications cable has been disconnected. | -Check the insertion of the connector. -Check the wiring for the cable. |
| E-022 | Main Axis Reverse Rotation Error | -The connector of the main motor encoder has not been firmly inserted. -The signal from the main motor encoder has been disconnected. | -Check the insertion of the connector. -Check the encoder Z phase signal by using IN/OUT setting mode. |
| E-025 | Lower Air Pressure Error | -Air pressure decrease detection input signal (ARS) was detected. | -Check the air pressure. |

| CODE | ERROR NAME | PROBABLE CAUSE | INSPECTION |
|-------|--|--|---|
| E-029 | X-Motor A Phase Defect Error | -The connector of X-axis motor cable has not been firmly inserted. -X-axis motor cable has been disconnected. | -Check insertion of the connector. -Check the wiring of the cable. |
| E-030 | X-Motor B Phase Defect Error | -The connector of X-axis motor cable has not been firmly inserted. -X-axis motor cable has been disconnected. | -Check insertion of the connector. -Check the wiring of the cable. |
| E-031 | Y-Motor A Phase Defect Error | -The connector of Y-axis motor cable has not been firmly inserted. -Y-axis motor cable has been disconnected. | -Check insertion of the connector. -Check the wiring of the cable. |
| E-032 | Y-Motor B Phase Defect Error | -The connector of Y-axis motor cable has not been firmly inserted. -Y-axis motor cable has been disconnected. | -Check insertion of the connector. -Check the wiring of the cable. |
| E-034 | USB system file error | -System file in the USB memory is broken. | -Check the system file in the USB memory. |
| E-037 | Main Axis Overload | -The load torque of the sewing machine is too large. | -Check the sewing machine. |
| E-038 | Main motor UVW sensor error | -The connector of the main motor has not been firmly inserted. -The signal from the main motor encoder has been disconnected. | -Check insertion of the connector. -Check the UVW phase signal by using IN/OUT setting mode. |
| E-039 | Main motor up positioning sensor error | -The connector of the main motor has not been firmly inserted. -The signal from the main motor encoder has been disconnected. | -Check insertion of the connector. -Check the UP signal by using IN/OUT setting mode. |
| E-040 | Main motor down positioning sensor error | -The connector of the main motor has not been firmly inserted. -The signal from the main motor encoder has been disconnected. | -Check insertion of the connector. -Check the DN signal by using IN/OUT setting mode. |
| E-041 | Main motor encoder error | -The connector of the main motor has not been firmly inserted. -The signal from the main motor encoder has been disconnected. | -Check insertion of the connector. -Check the A/B phase signal by using IN/OUT setting mode. |
| E-042 | Main motor Z phase sensor error | -The connector of the main motor has not been firmly inserted. -The signal from the main motor encoder has been disconnected. | -Check insertion of the connector. -Check the Z phase signal by using IN/OUT setting mode. |
| E-043 | Main motor U phase current offset error | -There is a trouble in the U-phase current sensor on the XC-B substrate. | -Please exchange XC-B substrate. -Please consult the sewing machine agent. |
| E-044 | Main motor V phase current offset error | -There is a trouble in the V-phase current sensor on the XC-B substrate. | -Please exchange XC-B substrate. -Please consult the sewing machine agent. |
| E-046 | Main Axis U Phase Defect Error | -Wiring to the main motor has been disconnected. | -Check wiring of the main motor. |
| E-047 | Main Axis V Phase Defect Error | -Wiring to the main motor has been disconnected. | -Check wiring of the main motor. |
| E-048 | Main Axis W Phase Defect Error | -Wiring to the main motor has been disconnected. | -Check wiring of the main motor. |
| E-053 | X Motor Encoder Error | -X-axis encoder connector has not been firmly inserted. -The signal from X-axis encoder has been disconnected. | -Check insertion of the connector. -Check the XA/XB phase signal by using IN/OUT setting mode. |
| E-054 | Y Motor Encoder Error | -Y-axis encoder connector has not been firmly inserted. -The signal from Y-axis encoder has been disconnected. | -Check insertion of the connector. -Check the YA/YB phase signal by using IN/OUT setting mode. |

| CODE | ERROR NAME | PROBABLE CAUSE | INSPECTION |
|-------|--|---|---|
| E-058 | X axis home positioning sensor error | -The connector of X-home sensor cable has not been firmly inserted. -X-home sensor cable has been disconnected. | -Check the insertion of the connector. -Check the X-axis home sensor signal by using IN/OUT setting mode. |
| E-059 | Y axis home positioning sensor error | -The connector of Y-home sensor cable has not been firmly inserted. -Y-home sensor cable has been disconnected. | -Check the insertion of the connector. -Check the Y-axis home sensor signal by using IN/OUT setting mode. |
| E-060 | PF axis home positioning sensor error | -The connector of PF-home sensor cable has not been firmly inserted. -PF-home sensor cable has been disconnected. | -Check the insertion of the connector. -Check the PF-axis home sensor signal by using IN/OUT setting mode. |
| E-061 | X axis A phase current offset error | -There is a trouble of current detection circuit on the PMD substrate. | -Please exchange PMD board. -Please consult the sewing machine agent. |
| E-062 | X axis B phase current offset error | -There is a trouble of current detection circuit on the PMD substrate. | -Please exchange PMD board. -Please consult the sewing machine agent. |
| E-063 | Y axis A phase current offset error | -There is a trouble of current detection circuit on the PMD substrate. | -Please exchange PMD board. -Please consult the sewing machine agent. |
| E-064 | Y axis B phase current offset error | -There is a trouble of current detection circuit on the PMD substrate. | -Please exchange PMD board. -Please consult the sewing machine agent. |
| E-066 | PMD substrate (XY axis) overcurrent error | -Wiring to X-motor or Y-motor is short-circuited. -The load torque of the XY table is too large. | -Check the wiring of the X and Y motor. -Check the sewing machine. |
| E-067 | PMD substrate (X axis) overcurrent error | -Wiring to X-motor is short-circuited. -The load torque of the XY table is too large. | -Check the wiring of the X motor. -Check the sewing machine. |
| E-068 | PMD substrate (Y axis) overcurrent error | -Wiring to Y-motor is short-circuited. -The load torque of the XY table is too large. | -Check the wiring of the Y motor. -Check the sewing machine. |
| E-069 | PF axis overcurrent error | -Wiring to PF-motor is short-circuited. -PF-axis 24V power supply cable has been disconnected. (inside of control box) | -Check the wiring of the PF motor. |
| E-072 | Power supply voltage decrease error | -Power supply voltage is too low than the power supply specification. | -Check power supply voltage. |
| E-075 | TE substrate communication error | -CON2 of the SOL substrate or CON1 of the TE substrate is not inserted firmly. -Communication cable of the TE substrate is disconnected | -Insert connectors (CON2 of the SOL substrate or CON1 of the TE substrate) firmly. -Exchange communication cable of TE substrate. |
| E-076 | TE substrate electromagnetic valve overcurrent error | -Output terminal and 24V terminal on the TE substrate is short-circuited. -There is a trouble at electromagnetic valve etc. which is connected with TE substrate. -Total output current of the TE substrate is over rating value. | -Check output wiring from TE substrate. And remove short-circuited point. -Exchange electromagnetic valve which is connected to TE substrate. -Use with below the rating current value. For example, decrease number of output, change to output device with low current value, shift on timing of each output, change setting of the full wave on time to smaller or zero. |
| E-077 | TE substrate 24V power supply error | -24V power supply is not supplied to the TE substrate. -24V power supply voltage is decrease. | -Check the connection of the 24V connector of the TE substrate. -Exchange the fuse of the TE substrate. -Check voltage of the power supply origin. |
| E-078 | Dynamic braking resistor over load error | -The inertia of the sewing machine (pulley etc.) is too large. -Power supply voltage is too high than the power supply specification. | -Lengthened deceleration time at the machine stop. -Check power supply voltage. |
| E-080 | PMD substrate 12V voltage decrease error | -External 12V power is short-circuited or decrease by the trouble of the operation panel. -External 12V power is short-circuited or decrease by the trouble of the SOL substrate or the halt switch lamp. | -Remove faulty point and exchange F2 fuse on the CPU substrate. |
| E-081 | XC-B substrate 12v voltage decrease error | -Internal 12V power is decrease or short-circuited by trouble in the CPU substrate or the DISP substrate. -Internal 12V power is decrease or short-circuited by trouble in the XC-B substrate. | -Remove faulty point and exchange F1 fuse on the CPU substrate. |
| E-082 | USB medium overcurrent | -USB MEDIUM IS OUT OF ORDER -NON-STANDARD USB MEDIUM BEING USED. | -CHECK USB MEDIUM (REFER P.[5]-1 FOR USB MEDIUM |

2. [M-***] Message code

| CODE | MESSAGE | SUB-MESSAGE |
|-------|---|--|
| M-001 | NEEDLE IS NOT CORRECT POSITION | RETURN NEEDLE TO UP POSITION BY HAND OR NEEDLE UP ICON |
| M-002 | NEEDLE THREAD WAS BROKEN | PLEASE THREAD THE NEEDLE |
| M-003 | CLAMP IS UP | TURN ON THE FOOT SWITCH (BLACK FOOT SWITCH) |
| M-004 | UP COUNTER SET VALUE UP | Please touch Enter Icon |
| M-005 | DOWN COUNTER REACHED SET VALUE | Please touch Enter Icon |
| M-006 | PATTERN DATA DOES NOT EXIST | READING OR TEACHING INPUT |
| M-007 | CLAMP IS NOT AT HOME POSITION | PRESS HOME ICON |
| M-008 | SERIAL DATA TRANSMITTING...(RS232C) | PLEASE WAIT FOR A WHILE |
| M-009 | SERIAL DATA RECEIVING...(RS232C) | PLEASE WAIT FOR A WHILE |
| M-010 | HALT SWITCH IS ON | PLEASE PUSH HALT SWITCH AGAIN |
| M-011 | PLEASE RUN SEWING MACHINE | PLEASE ROTATE THE SEWING MACHINE BY THE WINDER OR SEWING |
| M-012 | THE HALT SWITCH IS TURNED ON. | START SWITCH, +JOG, -JOG ICON IS INVALID. PLEASE TURN THE POWER OFF. *AFTER POWER LED IS TURNED OFF, TURN ON THE POWER. |
| M-014 | CURRENT UP COUNTER VALUE IS PROTECTED | PLEASE TURN OFF PROHIBITION WHEN CORRECTING. |
| M-015 | CURRENT DOWN COUNTER VALUE IS PROTECTED | PLEASE TURN OFF PROHIBITION WHEN CORRECTING. |
| M-016 | CURRENT COUNTER VALUE HAS EXCEEDED THE SET VALUE | CURRENT VALUE MUST BE SMALLER THAN SETTING VALUE |
| M-018 | THE SETTING TABLE NUMBER IS CHANGED | THE SET TABLE NUMBER IS SET IN THIS SEWING DATA |
| M-019 | SEWING DATA DOES NOT HAVE END CODE | PLEASE ADD END CODE |
| M-020 | START INPUT SIGNAL IS TURNING ON | PLEASE TURN OFF START INPUT SIGNAL |
| M-024 | CLAMP WILL MOVE TO THE SECOND HOME POSITION | ARE YOU SURE? Yes: ENTER ICON No: X ICON |
| M-026 | START SIGNAL AND JOG - ICON IS INEFFECTIVE | PRESS +JOG ICON |
| M-027 | NEEDLE UP POSITION DETECTION WARNING | THE MAIN SHAFT WILL ROTATE TO DETECT UP POSITION. ATTENTION BEING CAUGHT IN THE MACHINE. |
| M-028 | TERMINATION PROCESS COMPLETE | SEE YOU AGAIN! * WAIT UNTIL THE LED OF THE CONTROL BOX IS COMPLETELY OFF, THEN POWER THE SWITCH ON AGAIN. |
| M-029 | SETTING WILL NOT CHANGE | ARE YOU SURE? Yes: ENTER ICON No: X ICON |
| M-030 | STITCH POSITION IS DEVIATED FROM THE SEWING PATTERN | PRESS +JOG OR -JOG ICON, THEN START SEWING. |
| M-032 | THIS IS NOT COMPLIANT CODE AT THIS SYSTEM VERSION. | |
| M-033 | IT IS SET TO [M2H]=HP2 | PLEASE OPERATE IT AGAIN, AFTER IT SETS [M2H] IN ON OR OFF |
| M-034 | STITCH NUMBER COUNTER 1 REACHED TO SETTING VALUE | CLR: STITCH NUMBER COUNTER 1 IS CLEARED. ENT: CLEARS MESSAGE |
| M-035 | STITCH NUMBER COUNTER 2 REACHED TO SETTING VALUE | CLR: STITCH NUMBER COUNTER 2 IS CLEARED. ENT: CLEARS MESSAGE |
| M-036 | THE PATTERN CHANGES | PRESS HOME ICON |
| M-037 | INCORRECT RELEASE CODE | PLEASE INPUT AGAIN |
| M-038 | MACHINE HEAD TILT WAS DETECTED | THE MACHINE HEAD IS TILTED POSITION. IF MACHINE HEAD IS NORMAL POSITION, CHECK THE MACHINE TILT SWITCH AND CABLE. |
| M-039 | BOARD TEMPERATURE WARNING | BOARD TEMPERATURE IS HIGH |
| M-040 | STEP SEQUENCE PROGRAM ERROR | PLEASE CORRECT THE STEP SEQUENCE |
| M-042 | S6 SIGNAL BEING DETECTED | PLEASE RELEASE THE S6 SIGNAL. |
| M-043 | START PROHIBIT SIGNAL BEING DETECTED | PLEASE RELEASE THE START PROHIBIT INPUT SIGNAL. |
| M-044 | COUNTER REACHED SET VALUE | PLEASE CLEAR THE COUNTER. |
| M-050 | NOT IN THE HOME POSITION | PRESS HOME ICON |
| M-051 | ILLEGAL SETTING | PLEASE INPUT A CORRECT VALUE |
| M-052 | SET VALUE IS TOO LARGE | PLEASE INPUT THE VALUE WITHIN THE RANGE |
| M-053 | SET VALUE IS TOO SMALL | PLEASE INPUT THE VALUE WITHIN THE RANGE |
| M-054 | DATA DOES NOT EXIST | |

| CODE | MESSAGE | SUB-MESSAGE |
|-------|--|---|
| M-055 | TOO MANY STITCHES | PLEASE DECREASE THE NUMBER OF STITCH |
| M-056 | OUT OF DATA NUMBER(5000point) | PLEASE DECREASE THE INPUT POINT |
| M-057 | OUT OF AREA LIMIT | PLEASE MAKE THE DATA IN THE AREA LIMIT |
| M-058 | TOO SHORT STITCH LENGTH | PLEASE INPUT THE VALUE WITHIN THE RANGE |
| M-059 | TOO LONG STITCH LENGTH | PLEASE INPUT THE VALUE WITHIN THE RANGE |
| M-060 | SECOND HOME ALREADY EXISTS | ONLY ONE SECOND HOME POSITION POINT CAN BE INPUT |
| M-062 | TOO LONG NON STITCH FEED | PLEASE CORRECT NON STITCH FEED DATA |
| M-063 | NUMBER OF SKIP JOG IS OUT OF RANGE | PLEASE INPUT THE VALUE WITHIN THE RANGE |
| M-064 | COULD NOT CALCULATE | PLEASE DECREASE THE INPUT POINT AND THE AMOUNT OF THE MOVEMENT AND INPUT AGAIN |
| M-065 | NOT IN HOME POSITION | PRESS HOME ICON |
| M-066 | DATA TYPE IS DIFFERENT | PLEASE CONFIRM DATA TYPE |
| M-067 | CURVE DATA COULD NOT BE CREATED | PLEASE INPUT AGAIN REFERRING TO CURVE INPUT NOTES |
| M-068 | PREPARING IMAGE DISPLAY..... | PLEASE WAIT FOR A WHILE |
| M-070 | CURVE DATA CAN NOT BE CREATED | PLEASE REVIEW INPUT POINT |
| M-071 | THERE IS NO DATA TO BE DELETED | |
| M-072 | TRIMMING CODE CAN NOT BE INPUTTED OR ADDED | PLEASE INPUT AND ADD THE TRIM AFTER SEW |
| M-073 | CODE CAN NOT BE INPUTTED OR ADDED. | SAME CODE CAN NOT BE ADDED CONTINUOUSLY |
| M-074 | THE SECOND HOME POSITION CAN NOT BE INPUTTED | PLEASE INPUT AND ADD THE 2HD AFTER FEED |
| M-075 | THE END CODE CAN NOT BE INPUTTED | PLEASE INPUT AND ADD THE END AFTER FEED OR TRIM |
| M-076 | CIRCLE OR ARC COULD NOT BE CREATED | PLEASE REVIEW INPUT POINT |
| M-077 | THE OVERLAP BACK TACKING CANNOT BE SPECIFIED | THE OVERLAP BACK TAKING CAN BE USED ONLY FOR THE FIGURE WHERE CIRCLE, CURVE, AND BROKEN LINE SHUT. |
| M-080 | TOO LONG STITCH | PLEASE CHANGE THE PATTERN DATA |
| M-082 | ILLEGAL SETTING | PLEASE INPUT A CORRECT VALUE |
| M-083 | TRIM CODE CAN'T BE INPUTTED NOR ADDED | TRIM CODE CAN NOT BE ADDED JUST AFTER NEEDLE DOWN STOP CODE |
| M-084 | DSTP CODE CAN NOT BE INPUTTED NOR ADDED | NEEDLE DOWN STOP CODE CAN NOT BE ADDED JUST BEFORE TRIM CODE |
| M-085 | CLAMP POSITION HAS DEVIATED FROM INPUT COORDINATES | PLEASE RETURN TO HOME POSITION |
| M-086 | CLAMP POSITION HAS DEVIATED FROM INPUT COORDINATES | PLEASE RETURN TO HOME POSITION |
| M-087 | ZIGZAG DATA CAN NOT BE CREATED. | PLEASE CHANGE THE FEED AMOUNT OF ZIGZAG. |
| M-088 | MULTIPLE, ZIGZAG, BACK TACKING CAN NOT BE SET | |
| M-089 | DATA CAN NOT BE CREATED. | THE MISTAKE IS FOUND IN G DATA. |
| M-090 | CIRCLE OR ARC COULD NOT BE CREATED | PLEASE REVIEW THE INPUT POINT. |
| M-092 | CLAMP POSITION HAS DEVIATED FROM INPUT COORDINATES | EXCITATIONS OF THE MOTORS ARE RELEASED. MOVE THE CLAMP NEAR THE HOME POSITION BY HAND, THEN PRESS THE ENTER ICON. |
| M-093 | THICKNESS OF MATERIAL IS | CHANGES OK ? |
| M-094 | PRESSER FOOT IS DOWN | RAISE THE PRESSER FOOT (MATERIAL THICKNESS SETTING CAN BE DISPLAYED WHEN PRESSER FOOT IS UP POSITION.) |
| M-095 | MATERIAL THICKNESS IS OUT OF RANGE | SETTING VALUE OF MATERIAL THE THICKNESS IS OUT OF RANGE. PLEASE SET WITHIN FOLLOWING RANGE. |
| M-096 | MATERIAL THICKNESS SETTING VALUE WARNING | MATERIAL STEP OF CURRENT SEWING DATA IS OUT OF THE FOLLOWING RANGE. CONFIRM SETTING? YES:ENT, NO:X. |
| M-097 | INPUT VALUE IS OUT OF RANGE | INPUTTED MATERIAL STEP VALUE IS OUT OF SETTING RANGE. PLEASE SET WITHIN THE FOLLOWING RANGE |
| M-098 | MODIFICATION VALUE IS OUT OF RANGE | INPUTTED MATERIAL STEP VALUE IS OUT OF SETTING RANGE. PLEASE SET WITHIN THE FOLLOWING RANGE |
| M-099 | MATERIAL STEP IS OUT OF THICKNESS RANGE | MATERIAL STEP OF CURRENT SEWING DATA IS OUT OF THICKNESS SETTING VALUE. PLEASE MODIFY SEWING DATA. |
| M-100 | MAKING DATA... | PLEASE WAIT FOR A WHILE |
| M-102 | MAKE ARC DATA? | ARE YOU SURE? Yes: ENTER ICON No: X ICON |

| CODE | MESSAGE | SUB-MESSAGE |
|-------|--|--|
| M-103 | MAKE CIRCLE DATA? | ARE YOU SURE? Yes: ENTER ICON No: X ICON |
| M-104 | MAKE CURVE DATA? | ARE YOU SURE? Yes: ENTER ICON No: X ICON |
| M-105 | MAKE BROKEN LINE DATA? | ARE YOU SURE? Yes: ENTER ICON No: X ICON |
| M-106 | MOVING TO END DATA | PLEASE WAIT FOR A WHILE |
| M-107 | MATERIAL THICKNESS WARNING | MATERIAL STEP VALUE OF SEWING DATA IS OUT OF RANGE. PLEASE CHECK MATERIAL STEP VALUE. |
| M-108 | OUT OF DATA NUMBER(300point) | PLEASE DECREASE THE INPUT POINT |
| M-109 | PRESSER FOOT IS DOWN | RAISE THE PRESSER FOOT |
| M-120 | MOVING TO START POINT | PLEASE WAIT FOR A WHILE |
| M-121 | MOVING TO STARTING POSITION | PLEASE WAIT FOR A WHILE |
| M-122 | A SPECIFIED POSITION IS WRONG | PLEASE SPECIFY FOLLOWING STITCH FROM START POINT |
| M-123 | THE AMOUNT OF THE MOVEMENT IS NOT INPUT | PLEASE INPUT AMOUNT OF MOVEMENT |
| M-124 | A SPECIFIED POSITION IS WRONG | PLEASE SPECIFY SEWING DATA |
| M-125 | A SPECIFIED POSITION IS WRONG | PLEASE SPECIFY SEWING AND FEED DATA |
| M-126 | A SPECIFIED POSITION IS WRONG | PLEASE SPECIFY ONE STITCH FRONT IS SEW OR FEED DATA |
| M-127 | A SPECIFIED POSITION IS WRONG | PLEASE SPECIFY PREVIOUS DATA FROM FINAL STITCH |
| M-128 | A SPECIFIED POSITION IS WRONG | PLEASE SPECIFY CODE DATA |
| M-130 | SEWING DATA DOES NOT EXIST | THIS FUNCTION CANNOT BE USED |
| M-131 | A SPECIFIED POSITION IS WRONG | PLEASE SPECIFY ONE STITCH REAR IS SEW OR FEED DATA |
| M-140 | OFFSET DATA DOES NOT EXIST | |
| M-141 | MULTIPLE DATA DOES NOT EXIST | |
| M-144 | THE POINT INPUT DATA CANNOT BE CONVERTED. | PLEASE SPECIFY SEWING DATA OTHER THAN THE POINT INPUT. |
| M-145 | TACKING POSITION CAN'T BE CONVERTED | PLEASE SPECIFY SEWING DATA OTHER THAN THE POINT INPUT. |
| M-161 | HALT SWITCH IS ON | RELEASE HALT SWITCH. IF MESSAGE IS NOT CLEAR AFTER RELEASE HALT SWITCH, TURN THE POWER OFF AND CHECK HALT SWITCH & CABLE |
| M-162 | ILLEGAL NUMBER WAS SET | PLEASE SETTING AGAIN |
| M-164 | NOT G-DATA | PLEASE SPECIFY THE "G DATA" |
| M-165 | NOT G-DATA | PLEASE SPECIFY THE "G DATA" |
| M-180 | Cassette jig sensor is not detected | |
| M-188 | USB MEDIUM IS NOT CONNECTED | PLEASE CONNECT USB MEDIUM |
| M-189 | CAN NOT BE SAVED INTO USB MEDIUM | PATTERN DATA THAT WAS CREATED BY A FORMER SERIES CAN NOT BE SAVED |
| M-190 | USB MEDIUM DEFECT | PLEASE CHANGE USB MEDIUM |
| M-191 | INSUFFICIENT EMPTY AREA IN USB MEDIUM | PLEASE CHANGE USB MEDIUM OR DELETE FILES |
| M-192 | SPECIFIED DATA DOES NOT EXIST IN THE USB MEDIUM | CHECK FILE NAME AND PATTERN DATA NUMBER |
| M-193 | OPTIMIZING INTERNAL MEMORY | PLEASE WAIT FOR A WHILE |
| M-194 | CLEAR CONTENT OF THE SHORT CUT BUTTON | ARE YOU SURE? Yes: ENTER ICON(PATTERN DATA WILL NOT BE ERASED) No: X ICON |
| M-195 | WRITING SEWING DATA INTO USB MEDIUM | PLEASE WAIT FOR A WHILE |
| M-197 | READING SEWING DATA FROM USB MEDIUM | PLEASE WAIT FOR A WHILE |
| M-198 | OVERWRITES DATA IN USB MEDIUM | ARE YOU SURE? Yes: ENTER ICON No: X ICON |
| M-199 | DELETES SEWING DATA IN USB MEDIUM | ARE YOU SURE? Yes: ENTER ICON No: X ICON |
| M-201 | CORRESPONDING DATA DOES NOT EXIST IN USB MEDIUM | PLEASE CHANGE USB MEDIUM |
| M-202 | READING FILE INFORMATION OF THE USB MEDIUM | PLEASE WAIT FOR A WHILE |
| M-203 | USB MEDIUM IS CONNECTED | PLEASE DETACH USB MEDIUM |
| M-204 | READING COMPLETE | PLEASE DETACH USB MEDIUM |
| M-205 | WRITING COMPLETE | PLEASE DETACH USB MEDIUM |
| M-209 | INTERNAL MEMORY DEFECT | INTERNAL MEMORY WILL BE FORMATTED. PRESS ENTER ICON |
| M-210 | SAVED FILE NUMBER IS OVER LIMIT | PLEASE ERASE UNUSED DATA |
| M-211 | SPECIFIED SEWING DATA DOES NOT EXIST IN THE MEMORY | CHECK FILE NAME AND PATTERN DATA NUMBER |

| DE | MESSAGE | SUB-MESSAGE |
|-------|--|--|
| M-212 | MEMORY FORMATTING... | PLEASE WAIT FOR A WHILE |
| M-214 | THERE IS NO NUMBER THAT HAS BECOME EMPTY IN MEMORY | PLEASE DELETE UNNECESSARY DATA |
| M-215 | WRITING SEWING DATA INTO THE INTERNAL MEMORY... | PLEASE WAIT FOR A WHILE |
| M-216 | DELETING SEWING DATA IN THE INTERNAL MEMORY... | PLEASE WAIT FOR A WHILE |
| M-217 | READING SEWING DATA FROM THE INTERNAL MEMORY... | PLEASE WAIT FOR A WHILE |
| M-218 | DELETES SEWING DATA IN THE INTERNAL MEMORY | ARE YOU SURE? Yes: ENTER ICON No: X ICON |
| M-219 | OVERWRITES SEWING DATA IN THE INTERNAL MEMORY | ARE YOU SURE? Yes: ENTER ICON No: X ICON |
| M-220 | INSUFFICIENT EMPTY AREA IN THE INTERNAL MEMORY | PLEASE ERASE UNUSED PATTERN DATA, AND OPTIMIZE AN INTERNAL MEMORY. |
| M-222 | PATTERN DATA CAN NOT BE DELETED | CURRENT PATTERN DATA CAN NOT BE ERASED |
| M-223 | FORMATS INTERNAL MEMORY | ARE YOU SURE? Yes: ENTER ICON No: X ICON |
| M-224 | OPTIMIZES INTERNAL MEMORY | ARE YOU SURE? Yes: ENTER ICON (SEWING DATA WILL NOT BE ERASED) No: X ICON |
| M-226 | COMBINATION DATA CAN NOT BE CREATED | PATTERN DATA WHICH CONTAINS SECOND HOME POSITION CAN NOT BE USED FOR COMBINATION. |
| M-227 | CAN NOT CHANGE PATTERN DATA NUMBER | CAN NOT CHANGE TO PATTERN DATA NUMBER WHICH IS USING. |
| M-228 | OUT OF AREA LIMIT | PLEASE CHANGE PATTERN DATA |
| M-230 | CAN NOT READ | PRESS HOME ICON |
| M-231 | CAN NOT WRITE | PRESS HOME ICON |
| M-232 | TOO MANY STITCHES | PLEASE CHANGE PATTERN DATA |
| M-234 | ILLEGAL FILE NAME | PLEASE INPUT THE FILE NAME BY 8 CHARACTERS OR LESS |
| M-235 | ILLEGAL PATTERN NUMBER | PLEASE INPUT CORRECT SEWING DATA NUMBER. |
| M-237 | CHANGE PATTERN DATA TO G-DATA | ARE YOU SURE? Yes: ENTER ICON No: X ICON (BACK TO SELECTION SCREEN) |
| M-238 | INCORRECT PASSWORD | PLEASE INPUT AGAIN |
| M-240 | CAN NOT READ COMBINATION PATTERN | PLEASE CLEAR COMBINATION PATTERN (PRESS CLR ICON) |
| M-246 | NEEDLE IS NOT CORRECT POSITION | PLEASE ADJUST UP POSITION SENSOR OR [U8] SETTING |
| M-247 | TRIMMING OUTPUT WAS CANCELED | PLEASE ADJUST TRIMMING START TIME/ANGLE [TRS] |
| M-248 | TENSION RELEASE OUTPUT WAS CANCELED | PLEASE ADJUST TENSION RELEASE START TIME/ANGLE [LRS] |
| M-274 | CAN NOT USE COMBINATIONAL FUNCTION. | DISABLE THE FUNCTION OF PATTERN SELECTION BY USING OF EXTERNAL SIGNAL |
| M-275 | CAN NOT READ, BECAUSE THE COMBINATION IS BEING USED | PLEASE ENTER THE COMBINATION MODE ON FUNCTION MODE AND PRESS THE CLR ICON TO DEACTIVATE THE COMBINATION FUNCTION |
| M-276 | INCORRECT NUMBER OF PATTERN DATA | CAN NOT CHANGE TO FORMER SERIESE NUMBER OF PATTERN DATA |
| M-277 | COPIES REGISTERED SEWING DATA | ARE YOU SURE? Yes: ENTER ICON No: X ICON *IF THERE IS SAME NUMBER IN THE MEMORY, DATA IS OVERWRITTEN |
| M-278 | DELETES COMBINATIONAL SEWING DATA | ARE YOU SURE? Yes: ENTER ICON No: X ICON |
| M-279 | DELETES DOCKING SEWING DATA | ARE YOU SURE? Yes: ENTER ICON No: X ICON |
| M-280 | COPYING SEWING DATA FROM USB MEDIUM TO THE MEMORY... | PLEASE WAIT FOR A WHILE |
| M-281 | COPYING SEWING DATA FROM THE MEMORY TO USB MEDIUM... | PLEASE WAIT FOR A WHILE |
| M-283 | COPY FAILED | SOME SEWING DATA WERE NOT COPIED COMPLETELY. PLEASE CHECK THAT COPIED SEWING DATA. |
| M-287 | ILLEGAL SETTING | PLEASE SELECT SETTING FILE THAT IS CREATED ON SAME SEWING MACHINE MODEL |
| M-288 | THERE IS NO DIFFERENCE | |
| M-289 | PATTERN DATA DOES NOT EXIST | |
| M-290 | READING COMPLETE | PLEASE TURN OFF THE POWER. PLEASE RE-TURN ON THE POWER AFTER POWER LED (GREEN) OF THE CONTROL BOX IS TURNED OFF. |
| M-291 | READING SETTING FILE... | PLEASE WAIT FOR A WHILE |
| M-292 | READING STEP FILE... | PLEASE WAIT FOR A WHILE |
| M-293 | READING SYSTEM FILE... | PLEASE WAIT FOR A WHILE |
| M-294 | CURRENT USED TABLE IS OVERWRITTEN | ARE YOU SURE? Yes: ENTER ICON No: X ICON |

| CODE | MESSAGE | SUB-MESSAGE |
|-------|--|--|
| M-295 | COPIES SPECIFIED PATTERN DATA | ARE YOU SURE? Yes: ENTER ICON No: X ICON *IF THERE IS SAME NUMBER IN THE MEMORY,DATA IS OVERWRITTEN |
| M-296 | COPIES ALL PATTERN DATA | ARE YOU SURE? Yes: ENTER ICON No: X ICON *IF THERE IS SAME NUMBER IN THE MEMORY,DATA IS OVERWRITTEN |
| M-297 | OVERWRITES COMBINATION DATA | ARE YOU SURE? Yes: ENTER ICON No: X ICON |
| M-298 | CLEARs COMBINATION FORM | ARE YOU SURE? Yes: ENTER ICON No: X ICON |
| M-299 | MILLING CUTTER IS IN LOWER POSITION | PLEASE RAISE MILL, THEN TOUCH HOME ICON |
| M-300 | SETTING HAS BEEN CHANGED | PLEASE TURN OFF THE POWER. PLEASE RE-TURN ON THE POWER AFTER POWER LED (GREEN) OF THE CONTROL BOX IS TURNED OFF. |
| M-302 | WRITING MODEL AND LANGUAGE SETTING | PLEASE INPUT AGAIN |
| M-305 | INITIALIZES SET VALUE | ARE YOU SURE? Yes: ENTER ICON (ALL SETTINGS ARE INITIALIZED) No: X ICON |
| M-306 | USER FOLDER DOES NOT EXIST IN THE USB MEDIUM | USER FOLDER CREATION OK? Yes: ENTER ICON No: X ICON |
| M-307 | USER FOLDER DOES NOT EXIST IN THE USB MEDIUM | PLEASE CREATE USER FOLDER (USER_system) |
| M-309 | INITIALIZED SELECTED ITEM | ARE YOU SURE? Yes: ENTER ICON (SELECTED SETTINGS ARE INITIALIZED) No: X ICON |
| M-312 | NO SELECTED ITEM | INITIALIZATION IS NOT EXECUTED |
| M-313 | RECEIVE TIME OUT OF SERIAL COMMUNICATION | |
| M-314 | LANGUAGE SETTING IS CONFIRMED | ARE YOU SURE? Yes: ENTER ICON No: X ICON |

MITSUBISHI ELECTRIC CORPORATION

Printed in Japan

From the library of Superior Sewing Machine & Supply LLC - www.supsew.com