

# mitsubishi

Industrial Sewing Machine

TECHNICAL MANUAL  
MECHANICAL VERSION

Electronic Pattern Sewing Machine

Model PLK-B1008H

## 2. SPECIFICATION

### (1) Specification of mechanism

Sewing area	: X-Direction(left/right)	Y-Direction(fore/backward)
	: 100mm	80mm
Maximum sewing speed	: 700spm	
Sewing speed	: 10 steps variable from 200 to 700 stitch/min	
Stitch length	: 0.1 to 12.7 mm	
	(Adjustable from 0.1mm to 12.7mm by 0.1mm resolution. )	
Stitch type	: Single needle lock stitch	
Class of needle	: Schmitz 794 #230	
Needle bar stroke	: 56.6 mm	
Thread take up lever stroke	: 94 mm	
Stepping foot lift	: 16mm	
Work holder lift	: 20mm (25max.)	
Thickness of material	: Max 10mm	
Hook	: Barrel shuttle hook	
Bobbin	: Large size Steel bobbin	
Thread trimmer system	: Electric heat cut system	
	Amount of heating time is selectable by selecting setting table	
	Voltage IN : AC 210/230V OUT : AC 1V	
Pre heating	available by using Function Code 4	
Thread	: #8~#00 (Synthetic)	
Lubrication system	: Manual oiling	
Lubrication oil	: White machining oil	
X-Y drive system	: Stepping motor and timing belt drive	
	Intermittent or continuous feeding	
Machine dimension	: HEAD 410W x 780L x 540H	TOTAL 1200W x 780L x 1320L
Weight	: HEAD 92Kg	TOTAL 172Kg
Type of controller	: PLK-B-CU-20	

### (2) Specification of main motor

Type of motor : XL-554-20

From the library of: Superior Sewing Machine & Supply LLC

### 3-6 Installation of the power switch

If the power switch is purchased without assembling to the table, the power switch has to be attached with the following procedure.

- (1) Mount the power switch (NO.①) with the wood screw (NO.②) underneath the table as shown on the figure.
- (2) Fix the electric cords with the staples (NO.③) underneath the table.
- (3) Hook up the connector (NO.④) of the power switch (NO.①) to the connector (NO.⑤) of the cable (NO.⑥).
- (4) Hook up the connector (NO.⑦) of the cable (NO.⑥) to the connector of the control box (NO.⑧).
- (5) Connect the terminal (NO.⑨) to the terminal adapter on the transformer (NO.⑩).

Two terminal has been prepared on this transformer (for 210V and for 230V). Detail of wiring are informed in APPENDIX on this manual.

- (6) Connect the other terminal (NO.⑪) to the terminal adapter **PORT No.5** of the relay socket (NO.⑫).
- Detail of wiring are informed in APPENDIX on this manual.

These terminal adapter are located inside of the motor cover of machine head.

- (7) Attach the power plug (NO.⑬) to the another end of the power switch cord (NO.⑭). All the necessary parts are enclosed in the accessory box.

For detail description, please refer to APPENDIX 1 and 2 Wiring diagram.

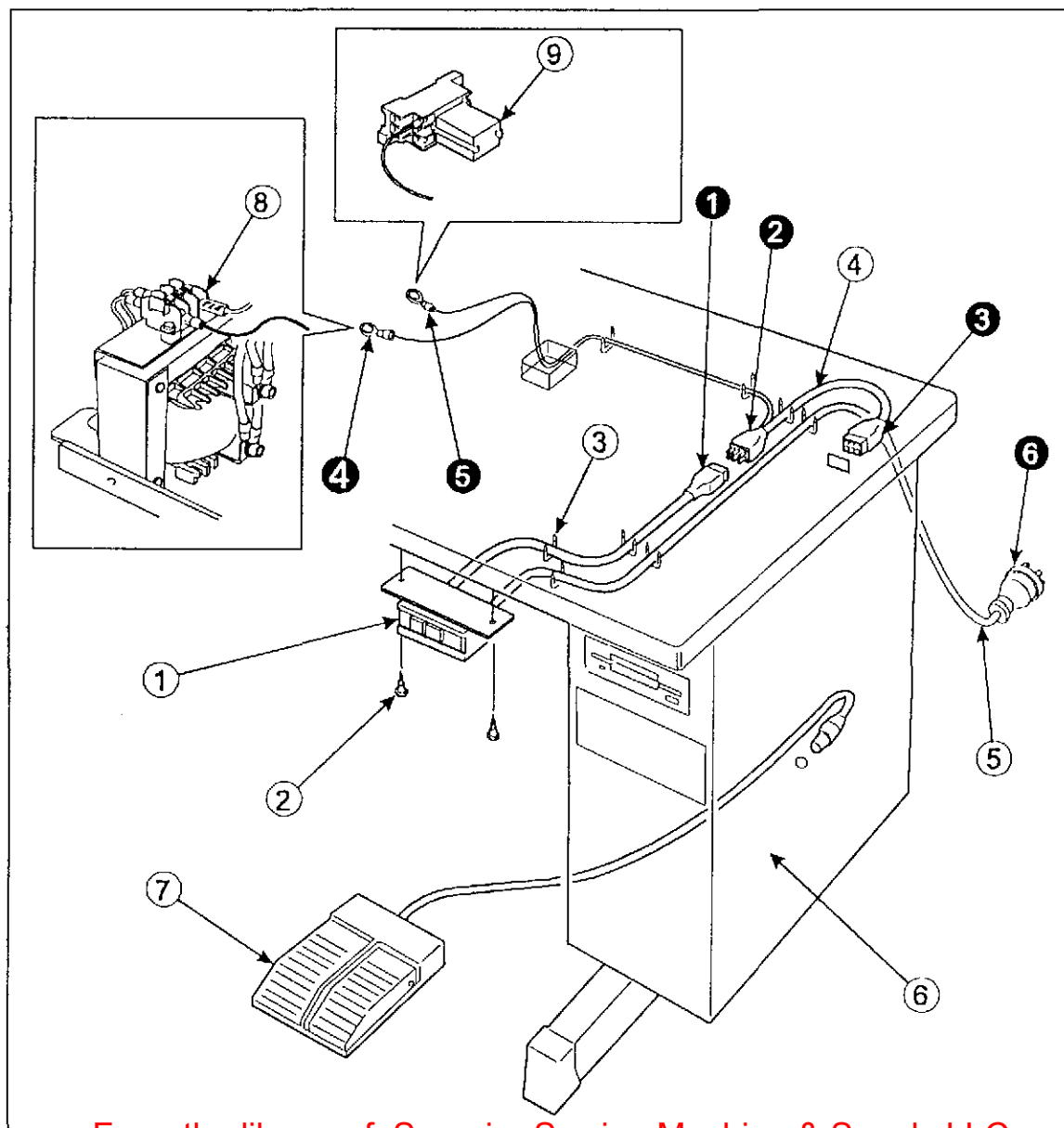

## 4. LUBRICATION



Caution

- ★ Please make sure to turn power switch OFF before oiling.
- ★ Please make sure to put some oil before starting the operation of the brand new machine or when the sewing machine is resumed the operation after along interval.

**[NOTE]** Please use high quality white machining oil.

Put some oil to red marked oil holes and other part as described below arrow sign.

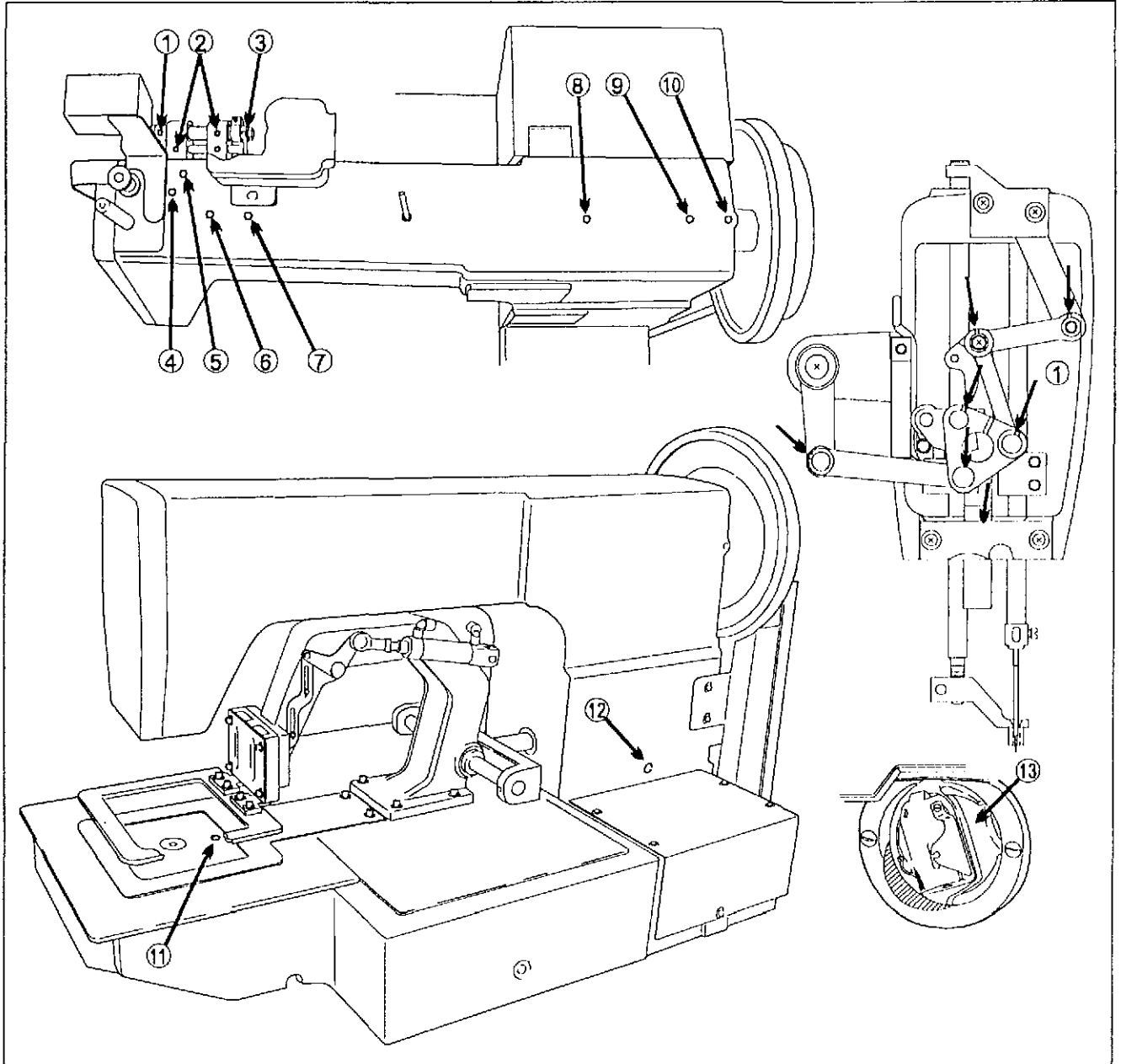

Lubrication position

- |                             |                                                  |                             |                       |
|-----------------------------|--------------------------------------------------|-----------------------------|-----------------------|
| 1. Presser foot mechanism   | 2. Rock shaft bushing                            | 3. Crank rod                | 4. Thread take up cam |
| 5. Thread take up shaft     | 6. Arm shaft bushing left                        | 7. Foot lifting eccentric   |                       |
| 8. Arm shaft bushing middle | 9. Connecting rod                                | 10. Arm shaft bushing right |                       |
| 11. Hook shaft bushing left | 12. hook shaft bushing right, Rock shaft bushing |                             |                       |
| 13. Hook driver             |                                                  |                             |                       |

From the library of: Superior Sewing Machine & Supply LLC

## 5-5-1 Taking out the bobbin

- (1) Turn the hand wheel by hand until the needle bar comes down to the lower point of its stroke so that case retaining spring (NO.②) in the shuttle body comes to recess part (NO.①) in the cover of the shuttle race body.

**NOTE** When "Down Angle of the needle bar" has been set, the hand wheel is rotated

automatically by pressing **NEEDLE UP/DN** Key on the teaching panel. The method to

set the down angle is shown in TECHNICAL MANUAL

<Teaching panel> 2.9.(5) "Down angle setting mode".

- (2) When the case retaining spring (NO.②) is pressed, the bobbin case (NO.③) will be opened and the bobbin (NO.④) will pop out the case.

## 5-5-2 Taking out the bobbin

- (1) After pulling out thread approximately 10cm from bobbin (NO.④), put the bobbin into bobbin case (NO.③).
- (2) Pass the thread through the threading groove (NO.⑤) in the bobbin case. At this time, with pulling the thread, check that the rotation of the bobbin (NO.④) is same as arrow of below figure.
- (3) Pass the thread through thread slit (NO.⑥) and pull it then, the thread can be passed under the thread tension spring (NO.⑦) and pulled out.
- (4) Push the bobbin case into the original position and turn back the hand wheel to up position.

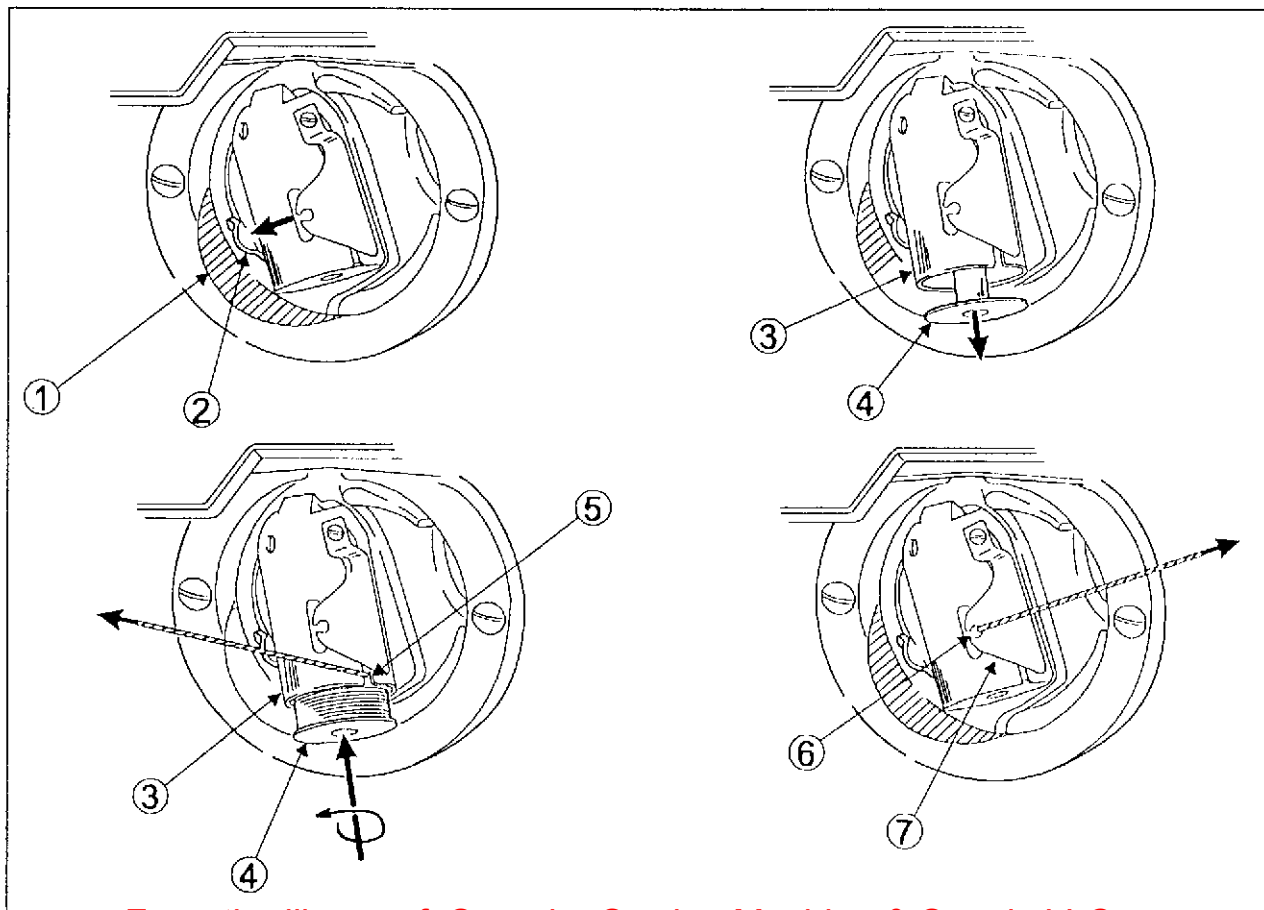

## 6-2. The teaching operation

Detail descriptions for pattern input are mentioned in TECHNICAL MANUAL <Teaching Panel>.

As for the input method of PLK-B1008H, it is necessary to operate the peculiarity compared with other PLK machines. Peculiar point is

**STOP code [USTP] just after TRIM code is required for thermal trimming sequence.**



### Caution

★ If STOP code is not put just after TRIM code, the X-Y table and needle will move during thermal trimming procedure and cause to damage the machine.

There are two ways to put STOP code in the pattern data (setting in the teaching mode and addition in the modification mode).

#### 6-2-1. Setting of STOP code in the teaching mode

- (1) Turn the pattern input key ON
- (2) Input pattern data as usual until just before the point where RETURN key is ON.
- (3) Turn CODE key ON at the point .  
  
(4) Turn 1 key and ENTER key ON  
  
(5) Turn 1 key and ENTER key ON
- (6) Turn CODE key ON again  
  
(7) Turn 2 key and ENTER key ON  
  
(8) Turn RETURN key ON  
(9) Turn END key ON

Display on teaching panel

1.CODE	2.CODE NUMBER	
3.EXTENDED CODE		1E

1.TRIM	2.USTP	
3.FUN1	4.2HP	1E

1.CODE	2.CODE NUMBER	
3.EXTENDED CODE		1E

1.TRIM	2.USTP	
3.FUN1	4.2HP	1E

#### 6-2-2. Addition of STOP code in the modification mode

- (1) Read the pattern data
- (2) Put MODIFY key ON
- (3) Put JOG+ key ON until point just after TRIM code.
- (4) Put FUNCTION key ON  
  
(5) Put 3 key and ENTER key ON  
  
(6) Put 2 key and ENTER key ON  
  
(7) Put ENTER key ON  
  
(8) Put 1 key and ENTER key ON  
  
(9) Put 2 key and ENTER key ON  
(10) Put 1 key and ENTER key ON  
(11) Put MODIFY key ON

1.STITCH	2.SPEED	
3.CODE	4.MOVE(B)	1E

1.DELTE CODE		
2.ADD CODE		1E

ADD JOG		****
X+***.*	Y+***.*	E

1.CODE	2.CODE NUMBER	
3.EXTENDED CODE		1E

1.TRIM	2.USTP	
3.FUN1	4.2HP	1E

USTP CODE		1.Y
ADDITION?		2.N

### 6-3. Pre-heating control

To secure the trimming, it is available to use pre-heating by input **Function Code No.4 (FN4)** in the pattern data. Relationship between FN4 and pre-heating behavior is described as below.

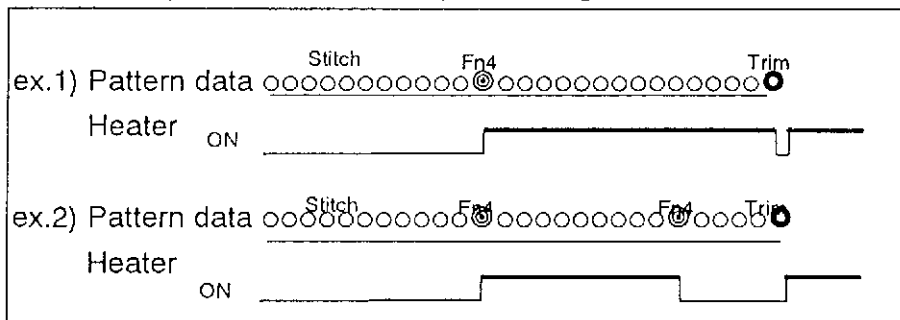

When FN4 code is input once, pre-heater is continue to on until trim code is appeared.(ex.1)  
 When FN4 code is input twice, pre-heater is on at first code and off at second code.  
 Usually FN4 is better to put only 1 time.

### 6-4. The thermal trimming operation

There are 3 operation switches for thermal trimming operation.

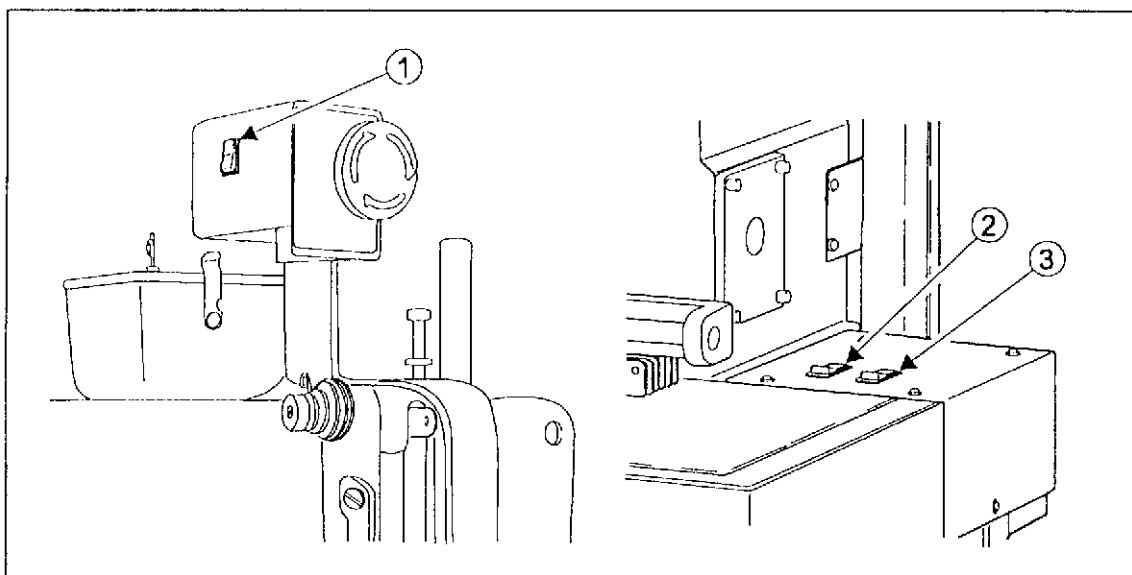

- The switch ① is **Manual / Test mode conversion switch**.
- The switch ② is **Enable / Disable lower thermal thread trimming device switch**.
- The switch ③ is **Enable / Disable upper thermal thread trimming device switch**.

**[NOTE]** Switch 2 and 3 does not work until power switch is off and on again for safety reason.

#### 6-4-1. Thermal thread trimming device switch (NO.②and ③)

The lower and upper thermal thread trimming device switch work as like below table.

Lower (NO.②)	Upper (NO.③)	Device action
ON	ON	Both trimmers work
ON	OFF	Lower trimmer works
OFF	ON	Do not work either
OFF	OFF	Do not work either

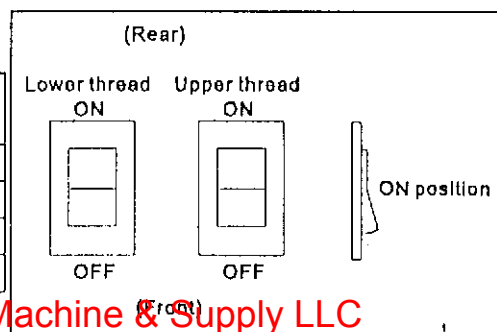

## 7. STANDARD ADJUSTMENT



### Caution

- ★ Please make sure to turn the power switch OFF before adjust the sewing machine.
- ★ If the adjustment is required under the power switch is ON, keep the start foot switch away from the foot.
- ★ Be careful not to be wounded by the needle or the inner hook point.
- ★ Please make sure to put the safety guards (Eye guard, Belt guard, Link cover and finger guard etc.) back on the original location after the sewing machine adjustment.

### 7-1 Adjustment of the shuttle

- (1) Turn the power switch OFF.
- (2) Turn the shuttle (NO.①) counterclockwise until it will go no further.
- (3) Put shuttle (NO.①) to come contact with the driver race (NO.②) by NO.① point.
- (4) Check a distance (NO.③) between the blade point of the shuttle (NO.①) and the end face of the shuttle race. Proper distance is 1mm. If distance is not proper, refer to following adjustment.
- (5) Turn the shuttle (NO.①) until at the point described in (1).
- (6) Loosen the bolt (NO.③).
- (7) Align the blade point of the shuttle (NO.②) by turning the shuttle by hand.
- (8) After adjustment has been completed, tighten screw (NO.③) firmly.

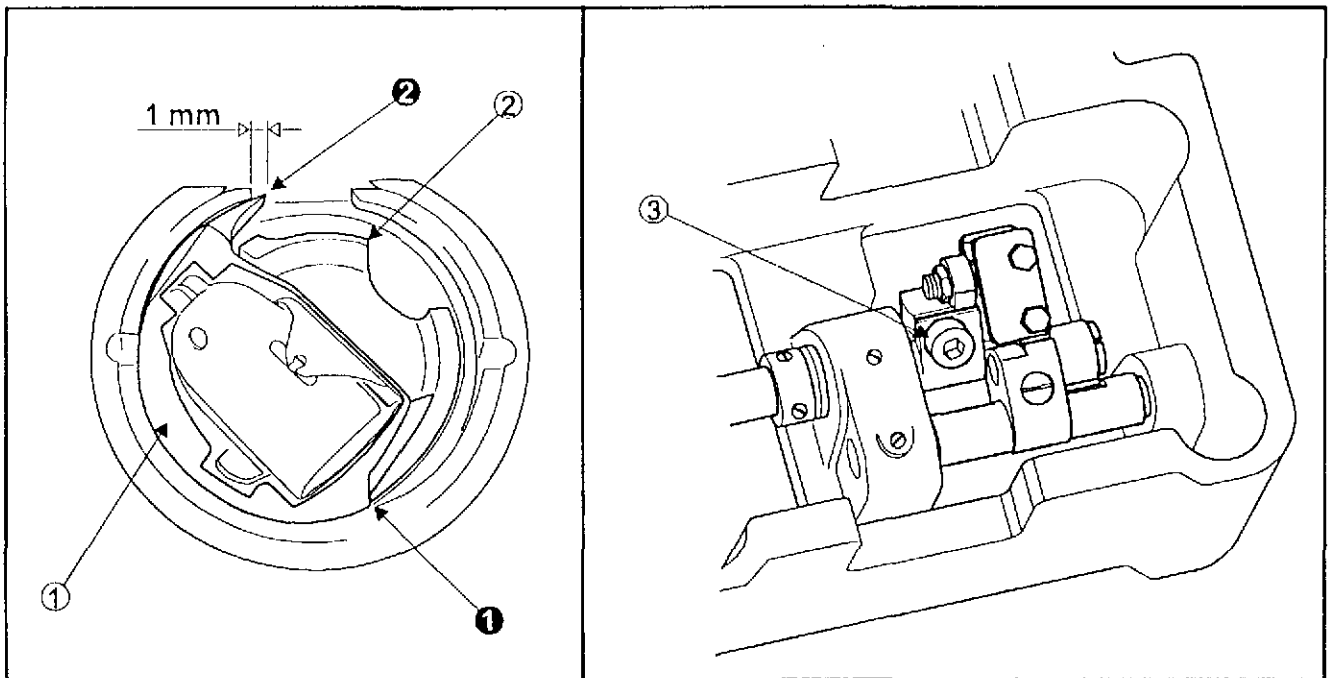

### 7-2 Adjustment of the position between the needle and the shuttle

- (1) Turn the hand wheel to make the needle bar ascend 5 mm from its lowest position.
- (2) At this time, blade point (NO.②) should be aligned with the center of the needle (NO.①).  
And the distance from the upper surface of the throat plate to the lower end of the needle bar should be 2.5 mm.



To adjust the position of the needle and shuttle, referring following procedure.

- (1) Remove the cover of the arm top.
- (2) Loosen screw (NO.③)
- (3) Loosen screw (NO.④), and adjust so that marker dot (NO.①) engraved on the eccentric cam of the vertical rod is aligned with marker line (NO.②) engraved on the main shaft.
- (4) Then, tighten screw (NO.④)
- (5) Turn the hand wheel counterclockwise, and check the lifting amount of the needle bar.
- (6) After the adjustment, securely tighten screws (NO.③ and ④).

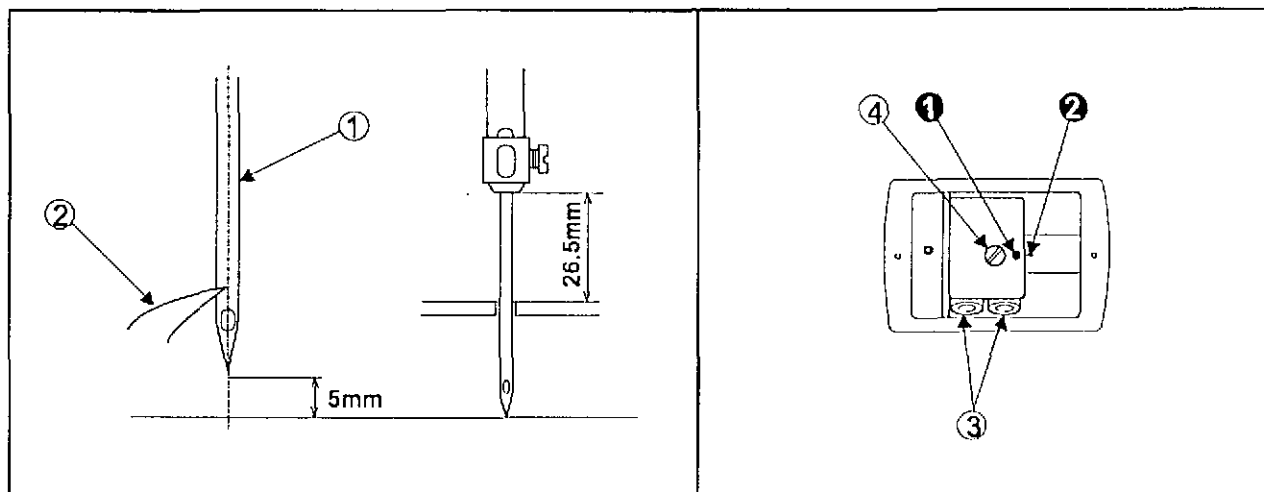

### 7-3. Adjustment of the needle bar height

The correct height is that the distance from the blade point of the shuttle (NO.②) to the upper end of the needle eyelet (NO.①) is 2.5 mm when the blade point of the shuttle is aligned with the center of the needle.

To adjust the height of the needle bar,

- (1) Loosen screws (NO.③).
- (2) Adjust the height by moving needle bar (NO.④) up and down.
- (3) After adjustment has been completed, tighten screws (NO.③) firmly.

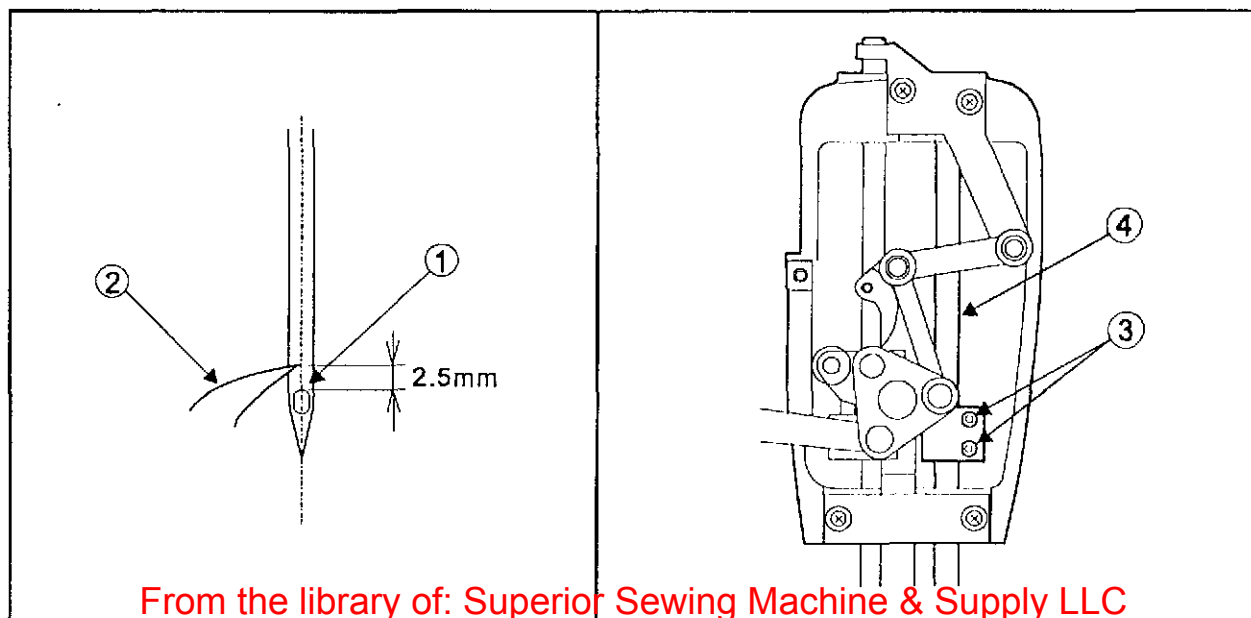

#### 7-4 Adjustment of the needle-to-shuttle clearance

Correct clearance between the recess in the needle (NO.①) and the blade point of the shuttle (NO.②) is 0.25 ~ 0.35 mm.

To adjust the needle-to-shuttle clearance,

- (1) Loosen screw (NO.③).
- (2) Adjust the clearance by moving shuttle driving shaft bushing (NO.④) to the left and right.
- (3) After adjustment has been completed, tighten screw (NO.③) firmly.

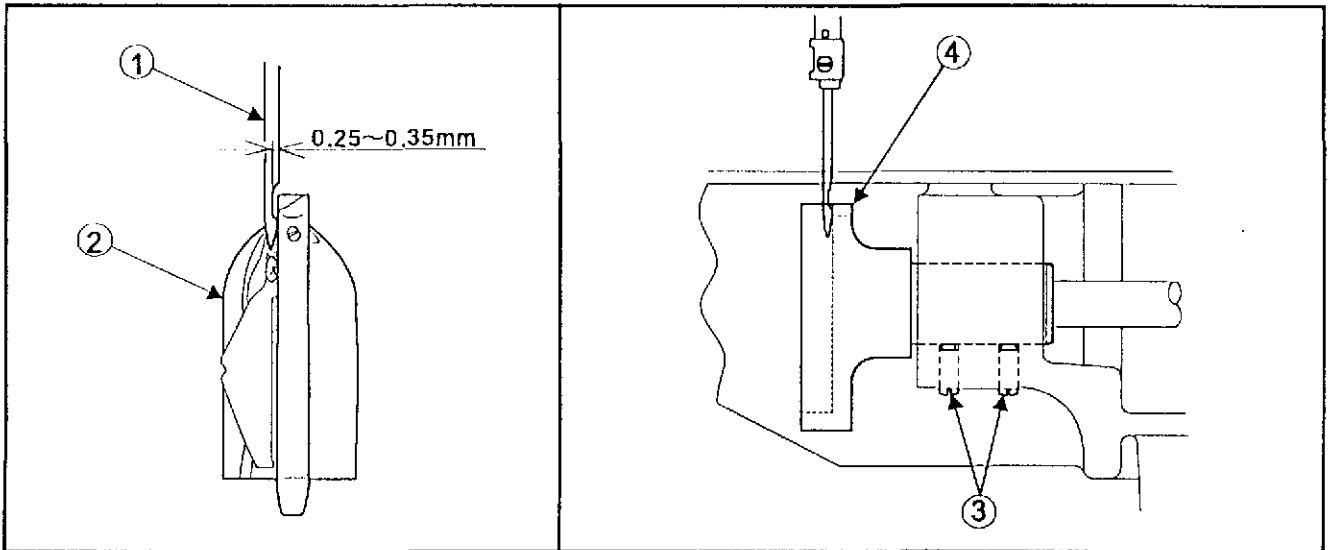

#### 7-5 Adjustment of the needle-to-driver clearance

Correct clearance between the needle (NO.①) and the needle guard of the driver (NO.②) has the range of 0 ~ 0.05 mm.

To adjust the needle-to-driver clearance,

- (1) Loosen two screws (NO.③) and Bolt (NO.④).
- (2) Adjust clearance by moving the shuttle driving shaft (NO.⑤) to the left and right.
- (3) After adjustment has been completed, secure the shuttle driving shaft thrust collar (NO.⑥) and the small pendulum (NO.⑦), making sure there is no axial play of the shuttle driving shaft.

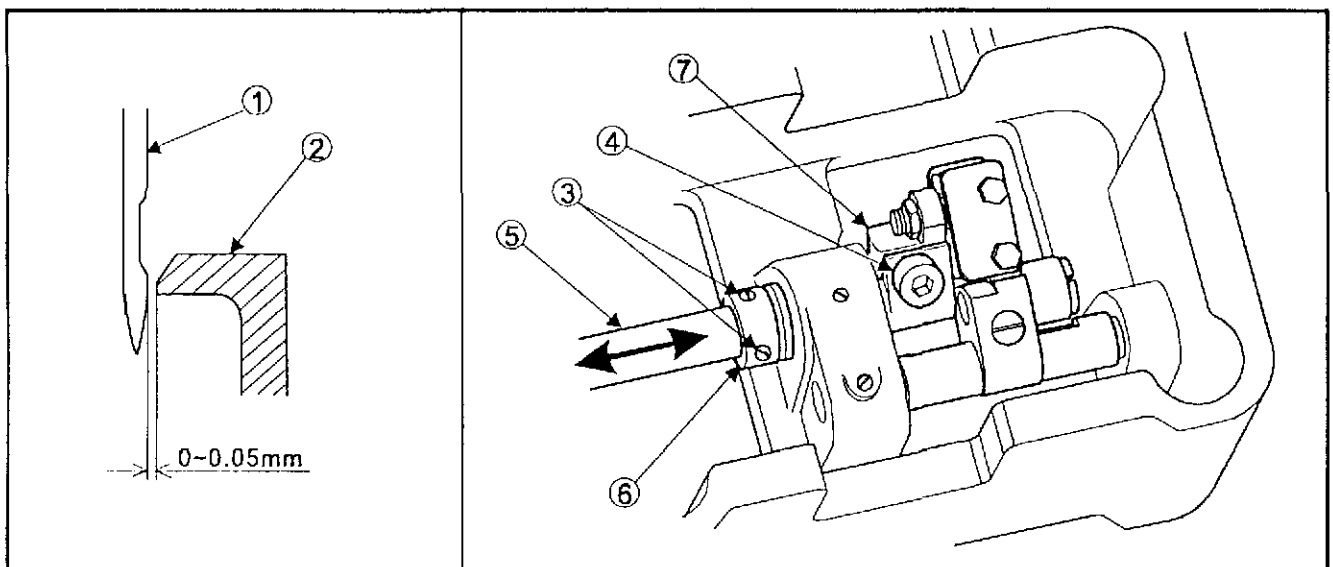

## The standard for adjusting the clearance between the needle and the blade point of the shuttle

Use a standard **Schmetz 794-Nm230** needle.

- (1) Adjust the clearance (NO.❶) between the convex section of needle (NO.❶) and driver (NO.❷) to 0.
- (2) Align the needle center with the blade point of shuttle (NO.❸) and press the NO.❷ section of the needle against the driver (NO.❷).
- (3) Adjust the clearance NO.❸ section to a minimum, with the needle (NO.❶) pressed against the driver (NO.❷), making sure that the needle (NO.❶) does not contact the blade point of the shuttle (NO.❸).

By this adjustment the needle-to-shuttle blade point clearance will be 0.25~0.35 mm.

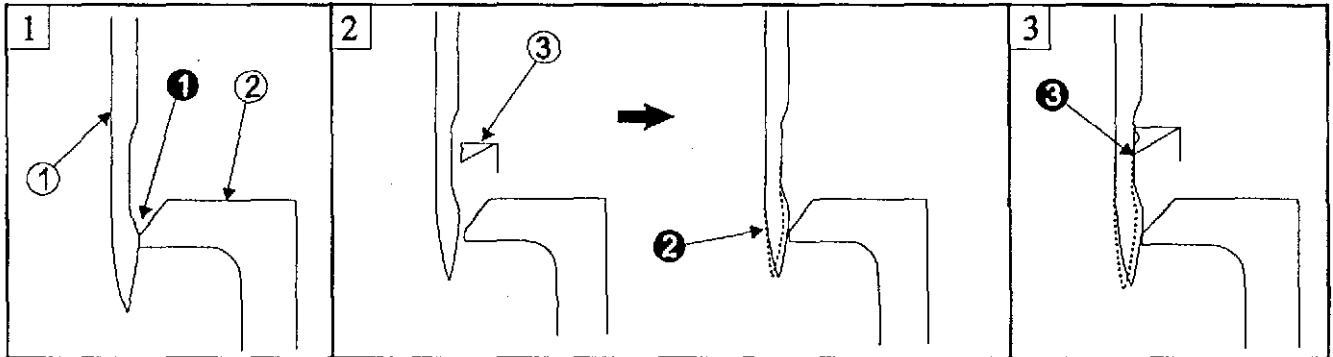

## 7-6 Test mode operation

### 7-6-1. Entrance for the test mode operation

The test mode operation is used for adjustment of mechanical position (height or stroke) for the thermal thread trimmer equipment and also for check the position of the sensors of the cylinders. For entrance this mode,

- (1) Turn the power switch ON.
- (2) Put on the gray foot switch (clamp switch).
- (3) Put on the RESET switch on the teaching panel.
- (4) Put on the gray foot switch again.
- (5) Reverse the mode conversion switch (NO.) to test mode position.

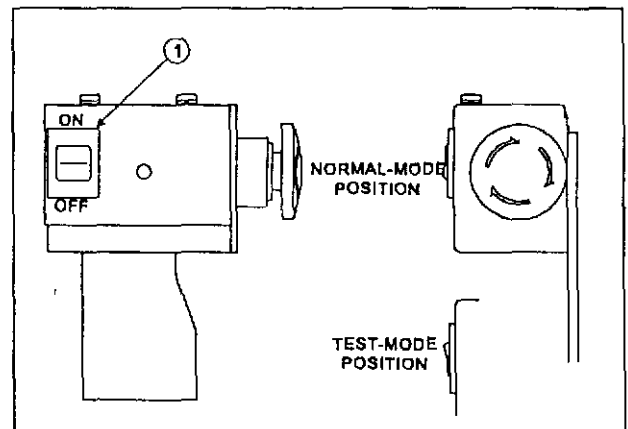

When the check of sensor is required in this operation mode, it is available to enter the E-mode. (Check input /output signal)

For enter E-mode,

- (1) Put on the **[F]** key in the setting panel of the control box.
- (2) Put on the **Up** arrow key and **Down** arrow key on the setting panel of the control box simultaneously over 3 seconds.

For description of the E-mode is described in the technical manual <CONTROL UNIT>.

**From the library of: Superior Sewing Machine & Supply LLC**

## 7-6-2. Key function in the test mode

In the test mode, each key on the teaching panel works to operate the thermal thread trimmer equipment (cylinders or relay) independently.

Relationship between the key and the equipment is as below.

Key NO.	Function
1	Push/Pull the <b>Tension release</b> cylinder
2	Push/Pull the <b>Thread puller</b> cylinder
3	Push/Pull the <b>Wiper</b> cylinder
4	Push/Pull the <b>Thickness detector</b> cylinder
5	Push/Pull the <b>Lower trimmer</b> cylinder
6	Push/Pull the <b>Upper trimmer</b> cylinder
7	On the Upper and Lower <b>heater</b> during 2 second
8	Return the equipment to original position ( <b>Reset</b> )
9	<b>1 cycle operation</b>
10	Push/Pull the <b>Presser foot</b> cylinder

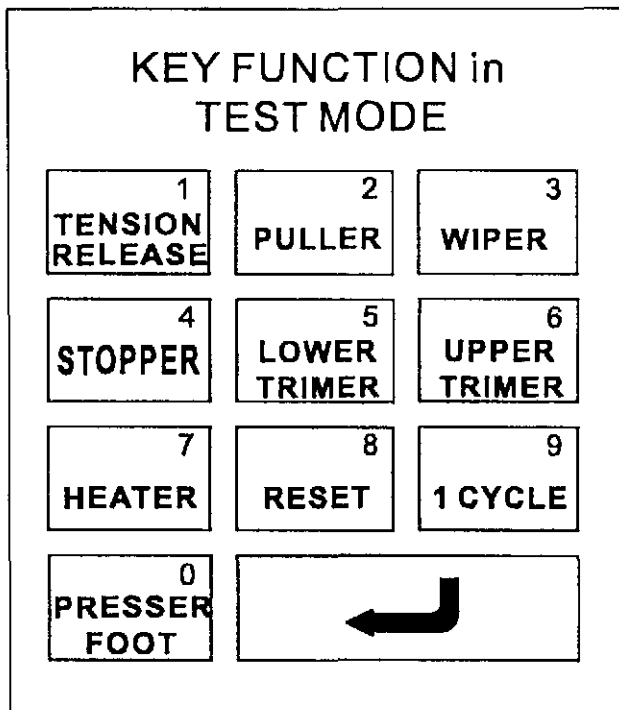

In the Test mode, Start switch is disabled.

Each key function has some rule like below

- ❖ From **KEY0** to **KEY9** is disabled when Clamp is up.
- ❖ **KEY3** is disabled when Presser foot is down.
- ❖ From **KEY4** to **KEY6** is disabled when Wiper is off.
- ❖ **KEY9** is available when Clamp is down and Presser foot is up.

After turning the mode conversion switch back to normal-mode, make sure to put on **KEY8(RESET)**.

**NOTE** Reset method against the trouble

When the thread trimmer device is stop by electrical problem (for example signal from sensor does not come), it is possible to return the device to original position and reset sequence program by under mentioned method.

- (1) Put the HALT switch ON and turning back the HALT switch to OFF.
- (2) Change mode switch to TEST mode.
- (3) Put the RESET key ON.

When the thread trimmer device is stop by mechanical problem (for example jam with thread), it is necessary to power switch OFF. In this case the presser foot keep up to avoid interference with thread trimmer device.

## 7-7 Adjustment of the presser foot

### 7-7-1 Adjustment of the driving shaft arm(front) and the presser foot

- (1) Turn the power switch OFF
- (2) Remove the side cover and the face cover.
- (3) Turn the sewing machine pulley by hand and stop the driving shaft arm-rear(NO.①) at its maximum swing position in arrow direction.
- (4) Disconnect the presser bar lifting link (NO.②) from the presser lift plate (NO.③) by removing the hinge screw (NO.④) .
- (5) Lift up the presser bar (NO.⑤) and the hand lift link (NO.⑥).
- (6) Insert the 12.7mm block
- (7) Tighten the screw (NO.⑦) of the driving shaft arm-front (NO.⑦) without the axial clearance of the driving shaft.
- (8) After the adjustment, connect the presser bar lifting link (NO.②) with the presser lift plate (NO.③) by setting the hinge screw (NO.④) and put the face cover and the side cover back on the original location.
- (9) Loosen the screw (NO.⑨) of the presser foot (NO.⑩) and then, adjust the presser foot position to be become the clearance between the bottom surface of the presser foot and the surface of the sewing material 0~0.5 mm.
- (10) Tighten the screw (NO.⑨) of the presser foot with to come down to the center of the needle hole of the presser foot.

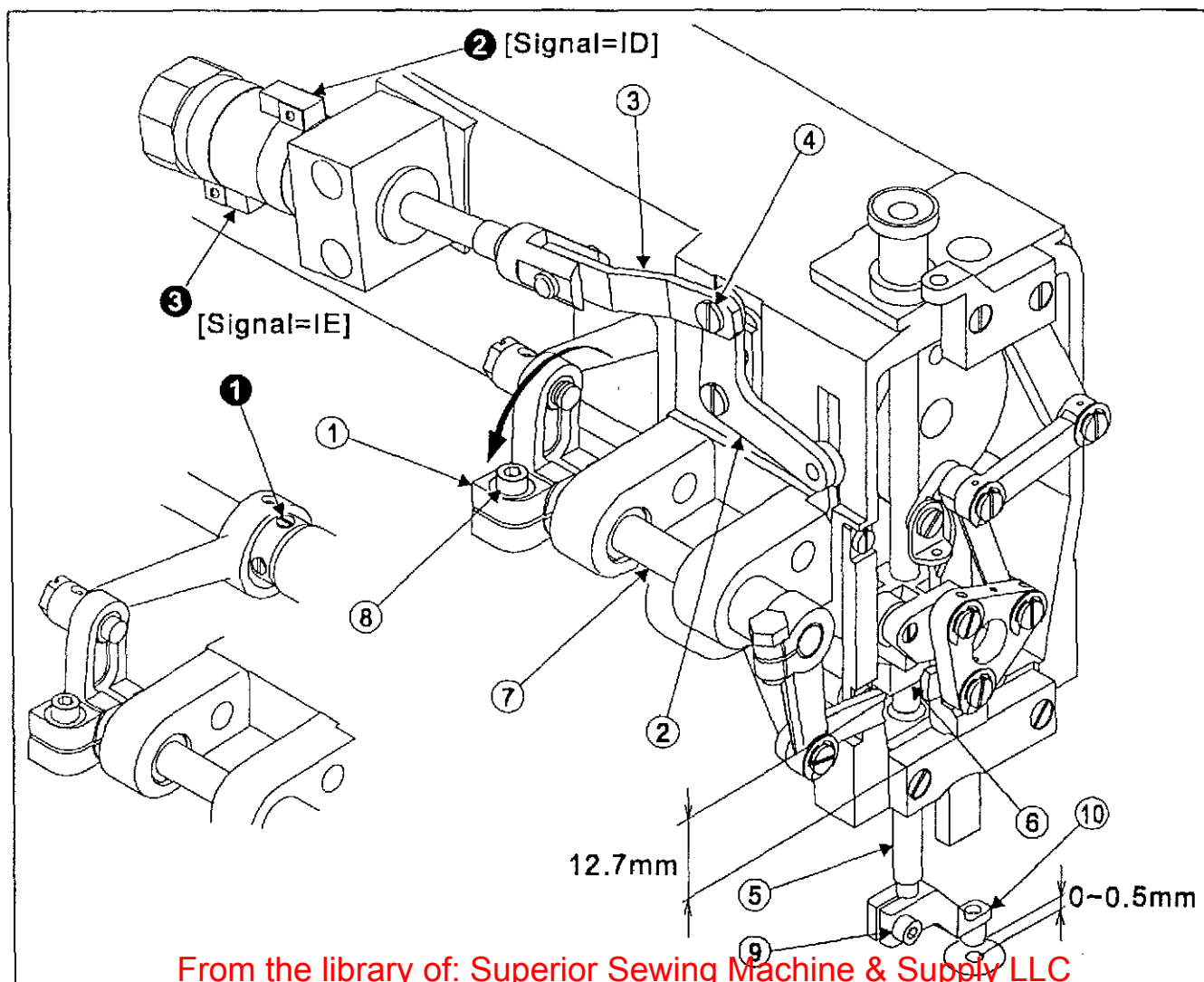

### 7-7-2 Adjustment of the sensor of the presser foot cylinder

At normal position, the sensor ID(NO.②) is ON and the sensor IE(NO.③) is OFF.

At activate position, these sensor will be reversed.

Check the sensors by using E-MODE (test mode)

### 7-8 Adjustment of the tension release

When tension close (the tension release plate (NO.②) leaves from the tension disc(NO.①) ), the sensor IC(NO.④) on the cylinder is ON and the sensor IB(NO.③) is OFF.

When tension open, (tension release plate approach to the tension disc), these sensors will be reversed.

Check the sensor IB and IC in E mode and TEST MODE simultaneously.

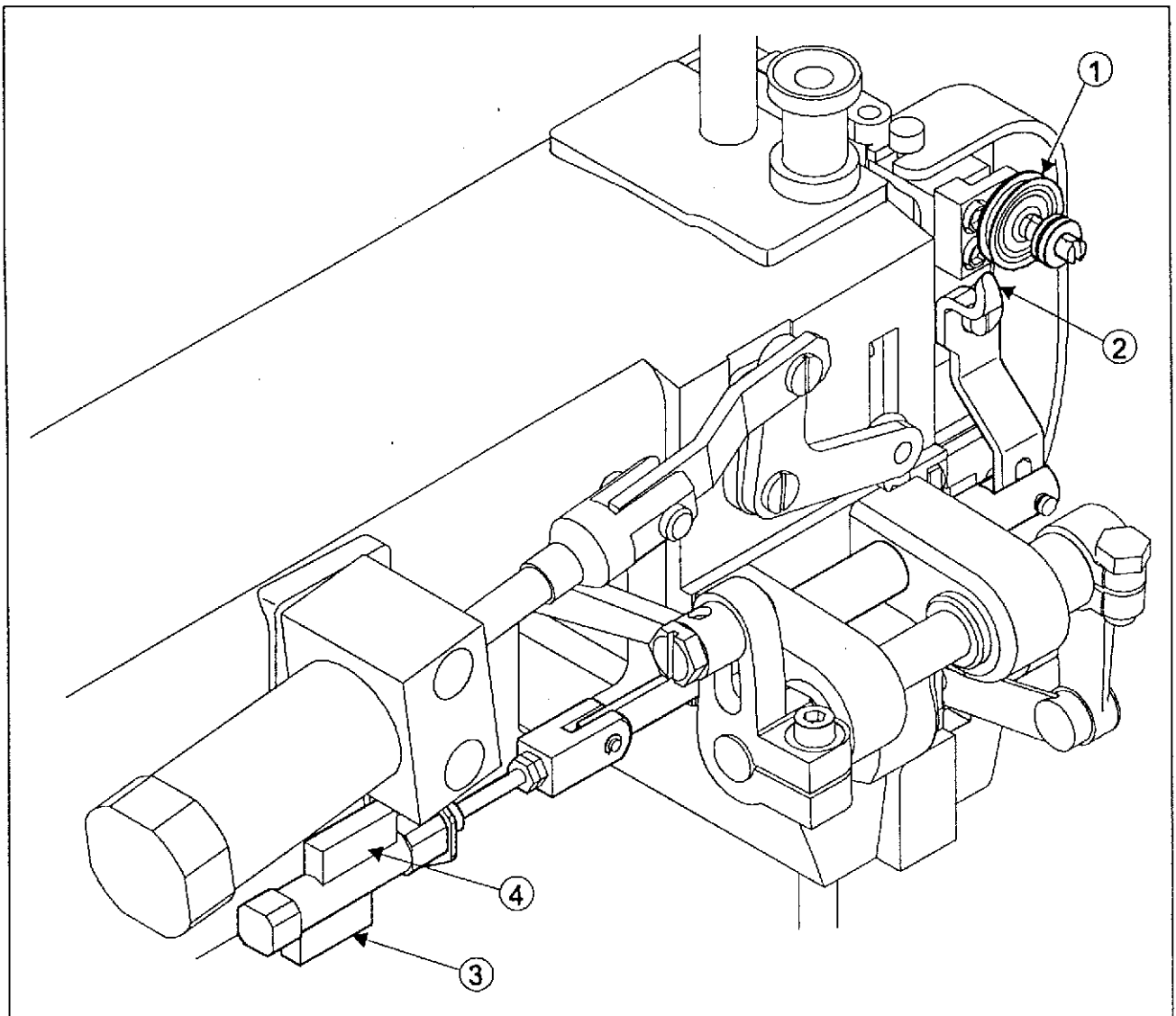

### 7-9 Upper thread heat cut device

#### 7-9-1 Setting thread puller

For a secure sewing at the seam beginning, a certain quantity of drawn-forward needle thread is required. The drawn-forward occurs after completion of seam with the clamps still lowered.

- ◇ The sewing pattern is finished.
- ◇ The needle stops in the high-position of thread lever.
- ◇ The presser foot lifted in it's up-position.
- ◇ The needle thread tension open.
- ◇ The thread puller pulls the required thread quantity forward.
- ◇ The thread puller moves back into its base position.
- ◇ The needle thread tension close again.
- ◇ the thickness detector lowers on the clamps.
- ◇ The thread wiper pulls the drawn-forward needle thread into the
- ◇ heating position.
- ◇ The upper heater lowers.
- ◇ The thread is heated off.
- ◇ The clamp move up.
- ◇ A new sewing sequence can be started.

The thread puller must be set so that, depending on the material to be worked, a secure seam beginning is assured. If the drawn-forward thread quantity is too small, the thread is too taut during heating, and The thread end doesn't melt together.

To adjust the drawn-forward thread quantity

- (1) Loosen the nut (NO.①).
- (2) Adjust the length [A] of the stopper screw (NO.②).
- (3) At this time, make sure that sensor I8(NO.③) of the thread puller cylinder (NO.④) functions at the end of the stroke of the cylinder. The sensor I8(NO.③) should be OFF at it's normal position and ON at it's drawn-forward position.
- (4) If the sensor doesn't function, adjust the sensor position to correct position.
- (5) Fasten the nut (NO.①).

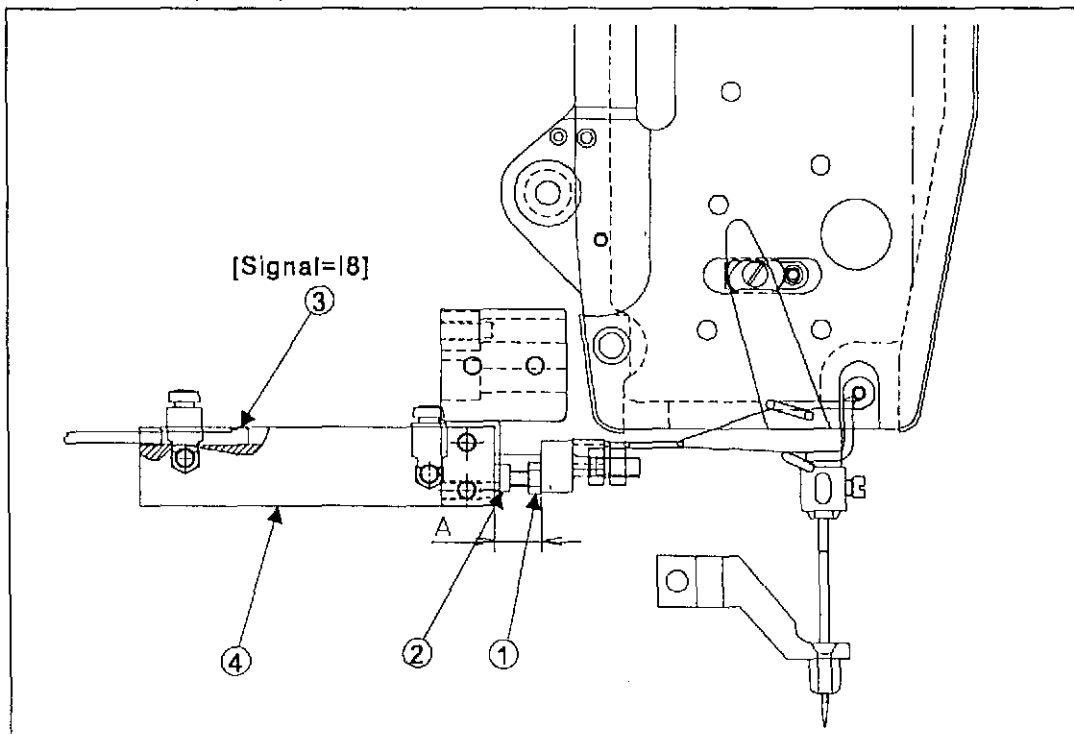

### 7-9-2 Setting of the thickness detector

- (1) Place material of the maximum allowable thickness (10mm) or spacer between the upper and lower clamp (NO.①).
- (2) Loosen the setting screw (NO.②) slightly.
- (3) Pull the thickness detector (NO.③) downward until it touches the lower clamp (NO.①).
- (4) Tighten the setting screw (NO.②) .
- (5) At this time, make sure the sensor I5 (NO.④) of the thickness detector cylinder (NO.⑥) functions. At upper (normal) position the sensor I5 should be ON.

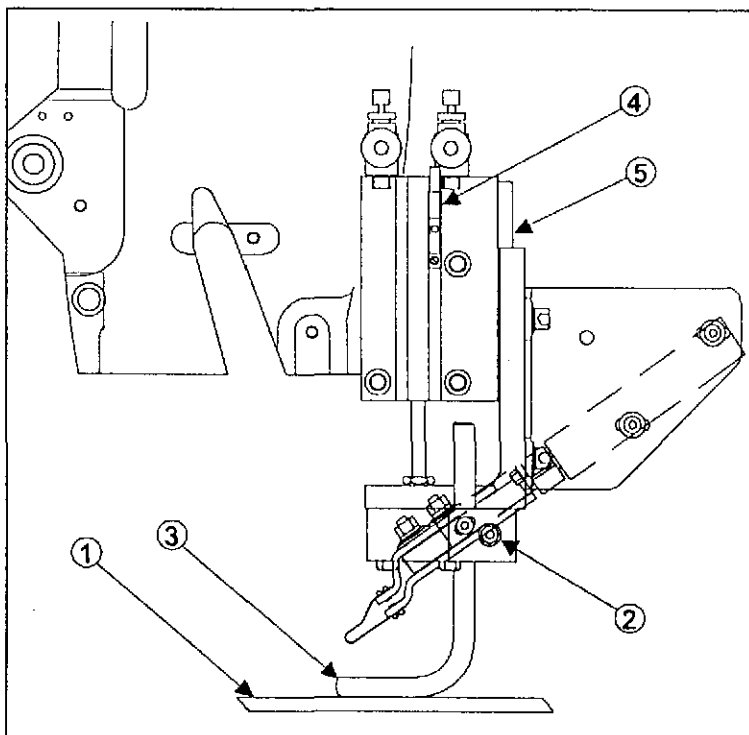

### 7-9-3 Setting of the thread wiper

The thread wiper pulls the thread quantity drawn-forward by the thread pull into the correct position for the heat-cut procedure. The drawn-forward thread quantity must be enough so that the thread is not under tension. Too high a tension leads to be a fraying of the thread during heat-cutting.

To correct the thread wiper stroke

- (1) Remove the rod cover (NO.①).
- (2) Loosen the nuts (NO.②).
- (3) Set the swing movement of the thread wiper (NO.③) by rotating the nuts (NO.②) up or down.
- (4) Tighten the nuts (NO.②) .
- (5) Replace the rod cover again.
- (6) After adjustment, check the position of the sensors I9(NO.④) and IA(NO.⑥) of the wiper cylinder (NO.⑥).

At the initial position of the thread wiper, the sensor IA must be ON and the sensor I9 must be OFF.

The thread wiper should move freely past under the needle.

To correct the height of the thread wiper

- (1) Place material of the maximum

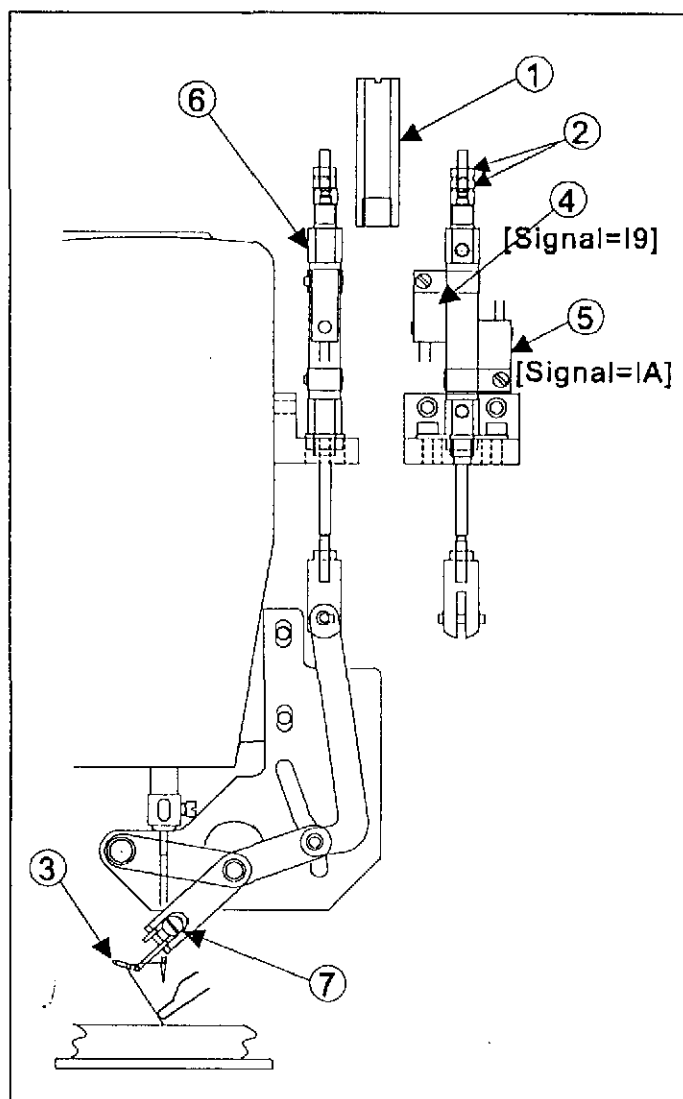



- (1) allowance thickness (10mm) or spacer between upper and lower clamp.
- (2) Swing the thread wiper manually past under the needle and check the thread wiper should not thereby strike against the needle. If the wiper interfere, adjust by following procedure.
- (3) Loosen clamping screw (NO.⑦).
- (4) Adjust the height of the thread wiper.
- (5) Tighten clamping screw.

#### 7-9-4 Adjustment of the upper thread heater

The upper heater must be an angle of approx. 90° to the thread positioned by the thread wiper. The fully extended heater must have a clearance of approx. 1 mm to the clamped material. The fully extended heater must touch on the thread positioned by the thread wiper with a slight pressure.

To adjust the position of the upper thread heater

- (1) Extend the heater (NO.①) manually.
- (2) Loosen the screws (NO.②) and the screws (NO.③).
- (3) Adjust the heater vertically and horizontally.
- (4) tighten the screws (NO.②and ③)and the screws.
- (5) After this adjustment, check the sensor I7(NO.④) of the heater cylinder (NO.⑥) should be ON and the sensor I6(NO.⑤) should be OFF at the normal position.

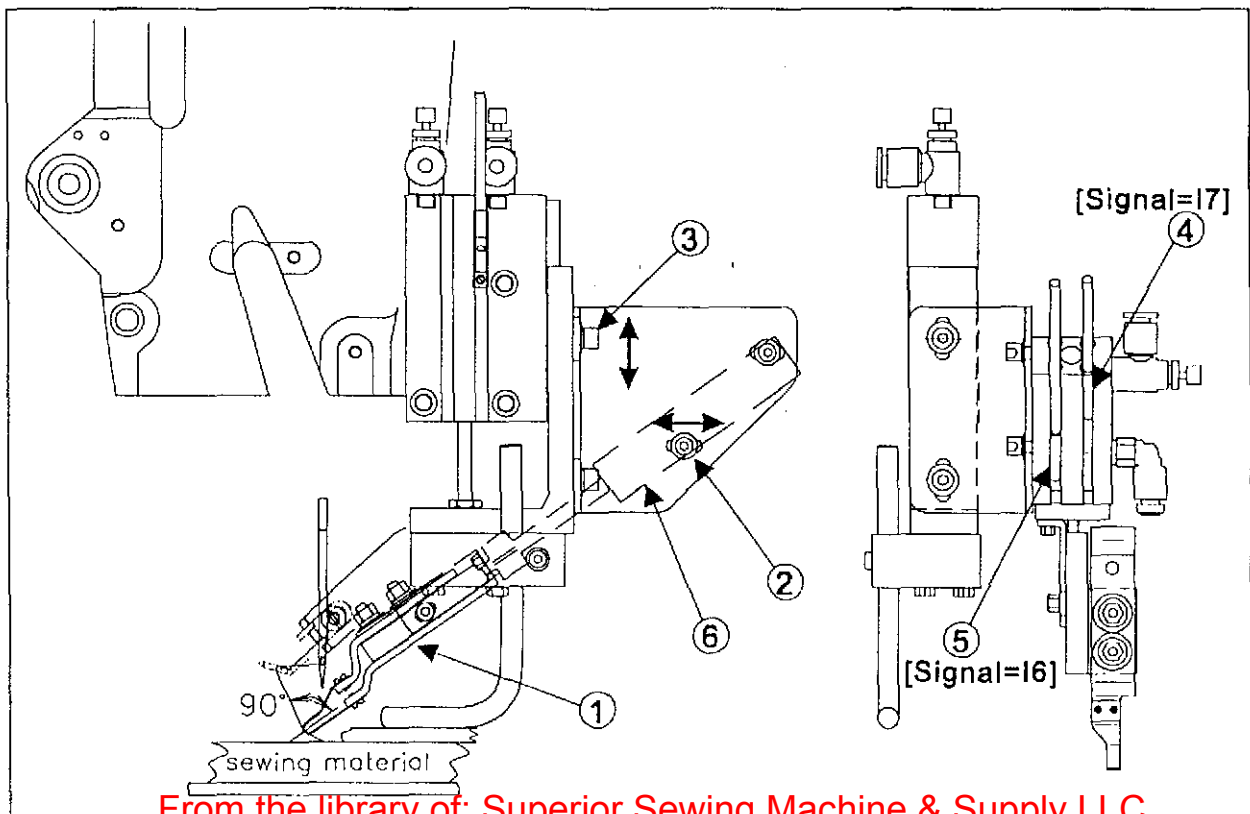

## 7-10 Adjustment of lower thread cut heater

The lower heater is in its initial position, when the thread puller is outside the area of needle hole.

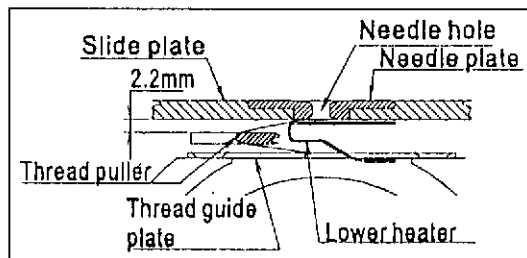

(1) Distance between thread puller and lower heater should be about 6mm.

For correction of the lower heater, loosen the screw and change the position of the thread puller.

(2) Distance between the edge of the cylinder and the joint should be about 34mm so that the left side of the lower heater is in line with the outer edge of needle plate bush.

For correction of the lower heater, loosen nut of the lower heater cylinder and adjust the length the cylinder rod.

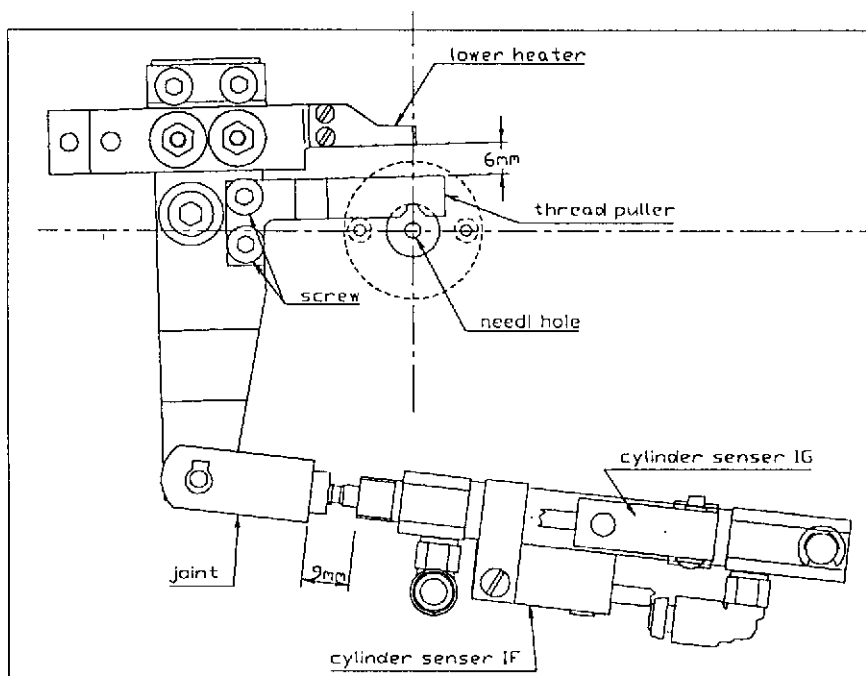

(3) Height of the lower heater in the normal position should not be touched any part.

For correction, bend the lower heater accordingly.

(4) Height of the lower heater in the normal position should be positioned 2.2mm lower than the slide plate.

For correction, bend the thread puller accordingly.

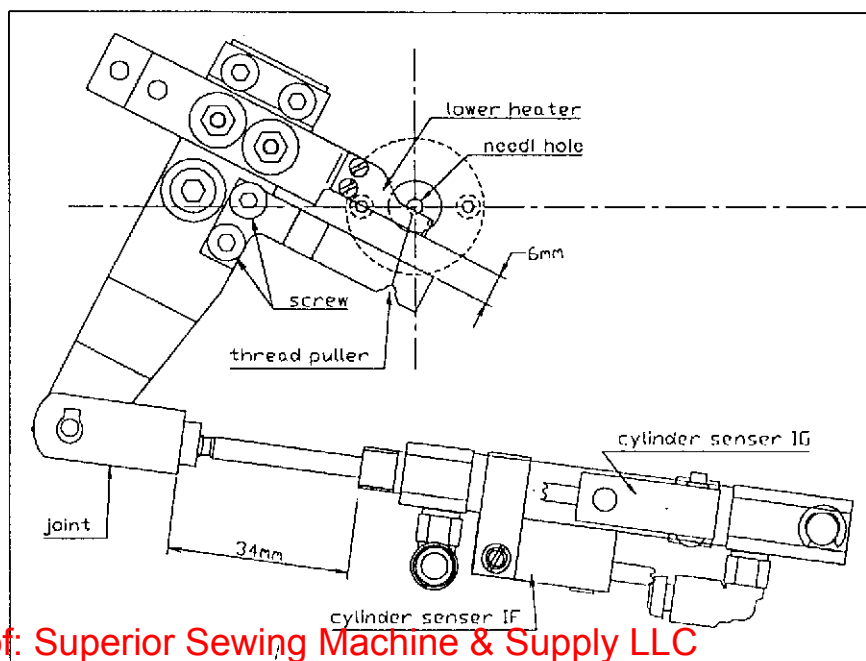

The standard stroke of thread take-up spring (NO.①) is 8 to 15 mm.

To adjust operating range,

- (1) Loosen screw (NO.②)
- (2) Adjust the operating range by moving thread the take-up spring adjusting plate (NO.③) up and down.
- (3) After adjustment, tighten screw (NO.②) firmly.

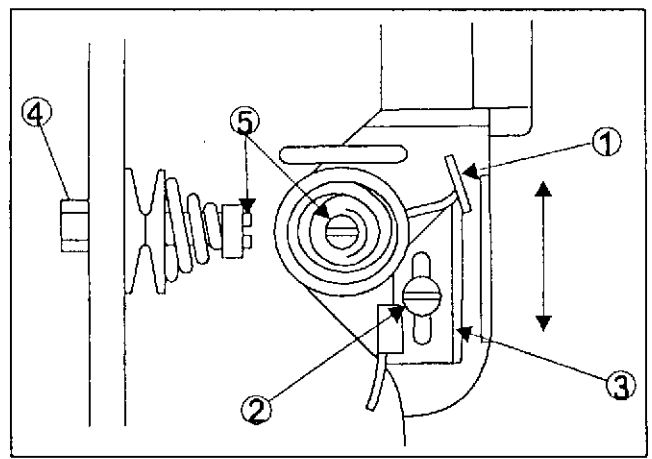

#### 7-14. Adjustment of the position detecting disc

The position detecting disc do not normally need to be adjusted but it should be checked that their positions stand in the relationship indicated below.

- (1) Draw out the synchronizer cover (NO.①) cable and remove it.
- (2) The synchronizer comes with 2 position detecting discs. The front disc (red) is used to detect the down position, and the rear disc (black) (NO.②) to detect the up position.
- (3) The rear disk (black) has a scale. Align the triangular mark (NO.①) of the front disc (red) at the 90 degree position on this scale. This setting is used for determine the start timing of X-Y table.



#### Caution

★ If the setting of discs is changed, accurate movement of X-Y table can not be performed.

- (4) Adjusting for up position thread take up lever is in high end), loosen screw (NO.③).
- (5) Turn the synchronizer bush (NO.④) with holding pulley.
- (6) After adjustment tighten screw (NO.③).

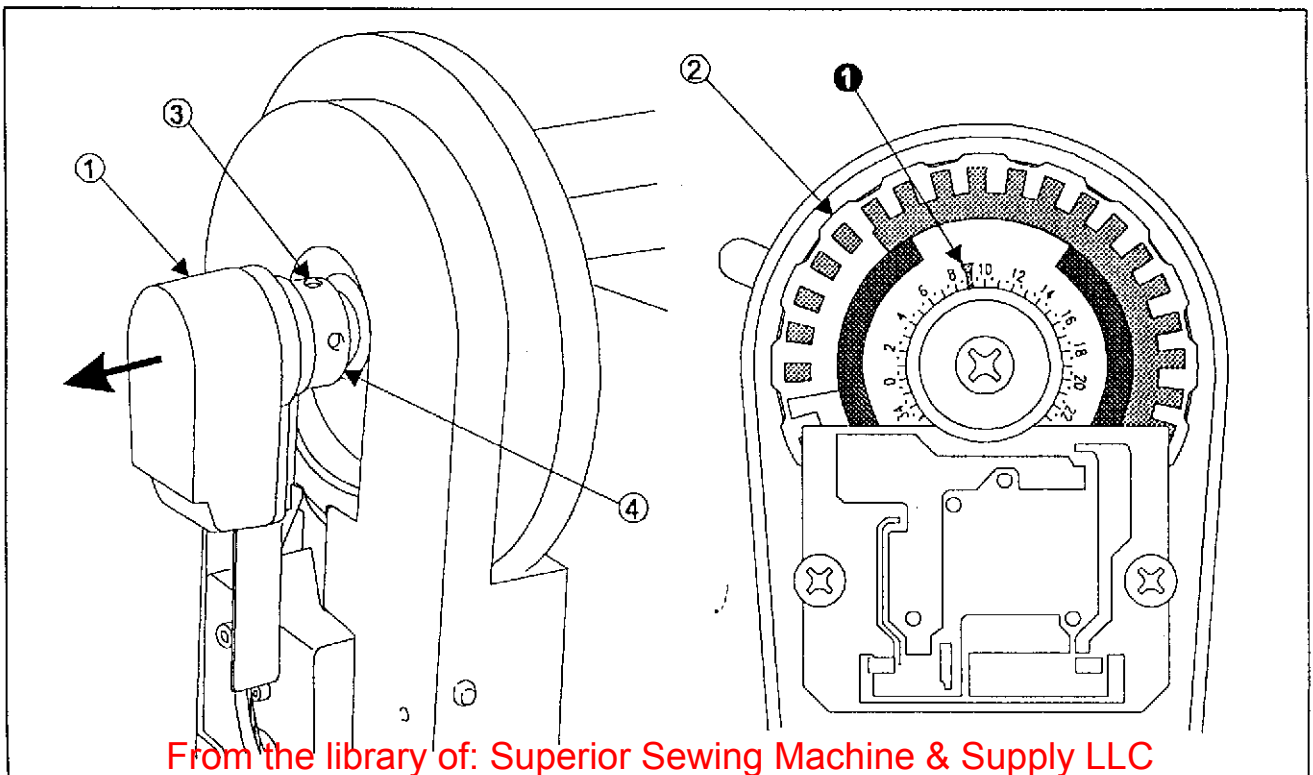

## 7-15. Adjustment of the mechanical home position

[NOTE] The mechanical home position is fixed at the center of the sewing area when the sewing machine is shipped from the factory. However, it can be moved within the area covered with diagonal lines.

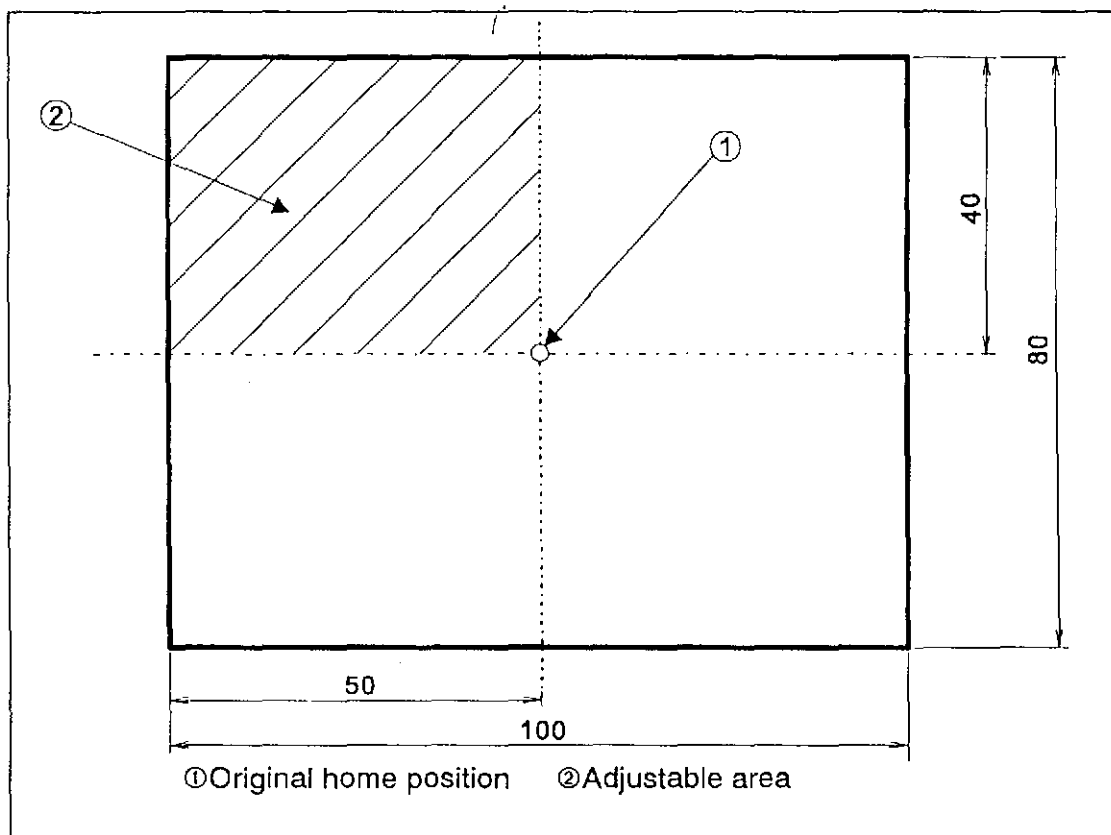

- (1) Turn the power switch ON and cancel the sewing area limit with the setting panel of the control box. For this cancellation, at the normal mode condition of the setting panel, push **F** key (No.1) then, press **↓** key (No.2) and **A** Key (No.3) at the same time for more than 2 seconds. The display **ALCon** is appeared and the sewing area limit is canceled.

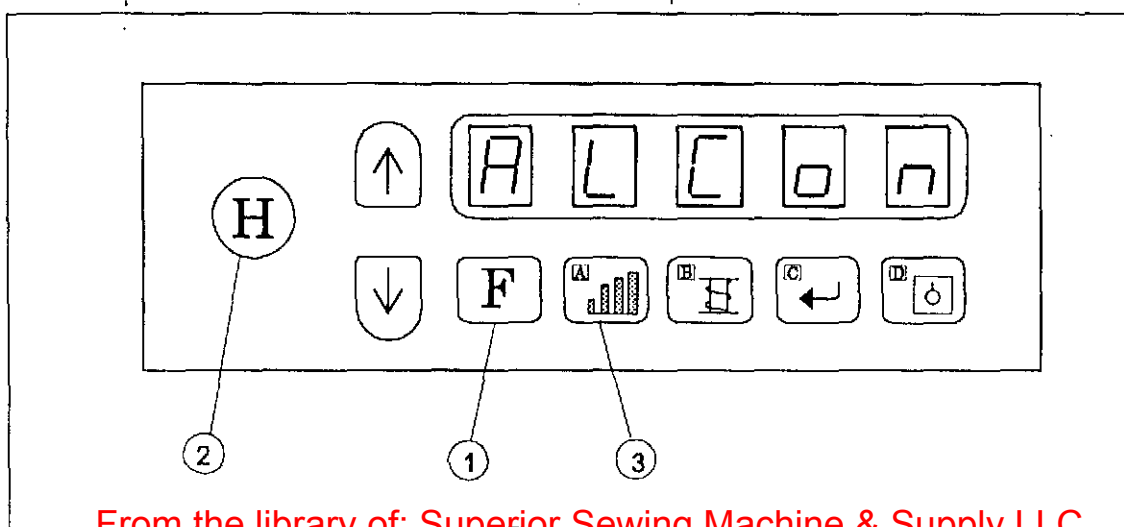

[NOTE] If do not cancel the sewing area limit, shifting the mechanical home position make the effective sewing area narrower than the original.

(Example) If shift the mechanical home position to the X direction 30mm, the Y direction 20mm without canceling the sewing area limit, the area covered with diagonal lines becomes invalid and the effective sewing area becomes narrower as a bold rectangle shown on the figure.

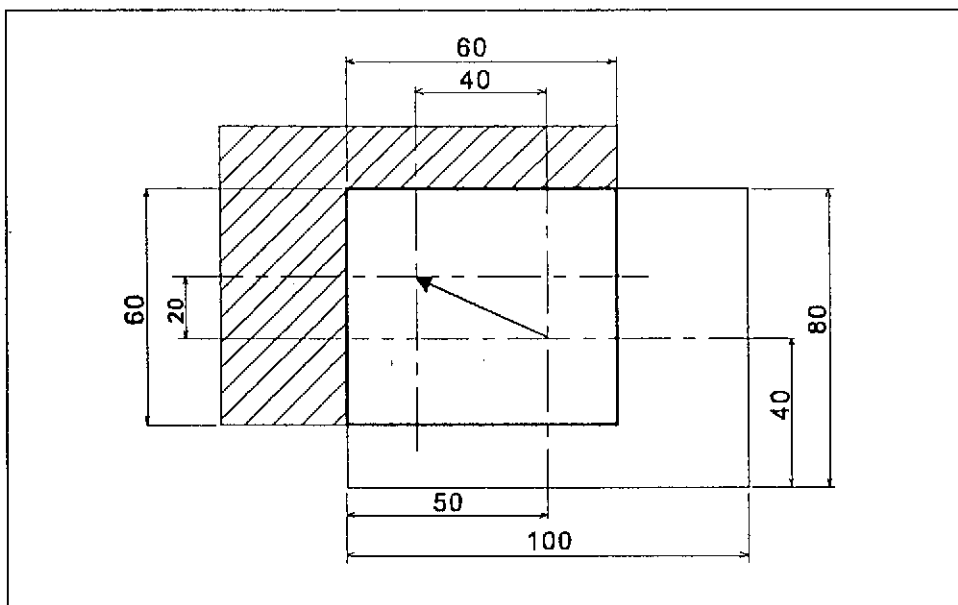

(2) After the cancellation of the sewing area limit, once, turn the power switch OFF.

#### 7-15-1. Shifting the mechanical home position to the X direction

- (1) Loosen the detector plate fix screws (2 pieces) (NO.①). If move the detector plate (NO.②) to the right, the mechanical home position is shifted to the right and if it is moved to the left, the mechanical home position is shifted to the left.
- (2) After the mechanical home position shifting, tighten the detector plate fix screws(2 pieces) securely.

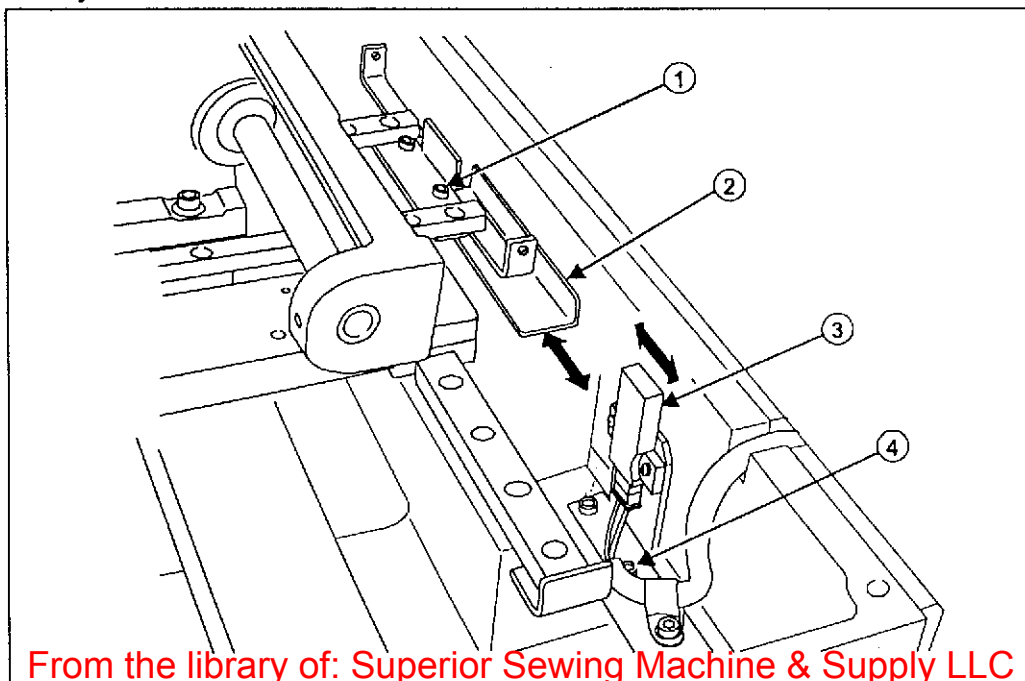

From the library of: Superior Sewing Machine & Supply LLC

- [NOTE] (a) In the case described above, available amount of adjustment of the home position is 0 to 25mm.  
For further adjustment, Loosen set screw(NO.④) and move position of the detector adapter(NO.③).
- (b) If move the detector adapter(NO.③) to the right, the mechanical home position is shifted to the left.
- (c) After adjustment, tighten the set screw(NO.④).

#### 7-15-2. Shifting the mechanical home position to the Y direction

- (1) Remove the V-belt cover and cover plate of the machine arm tail.
- (2) Loosen screws(NO.①) of the Adjuster plate(NO.②). If move the Adjuster plate(NO.②) to front , the mechanical home position is shifted to the backward.
- (3) After the mechanical home position shifting, tighten the screws(NO.①) securely.

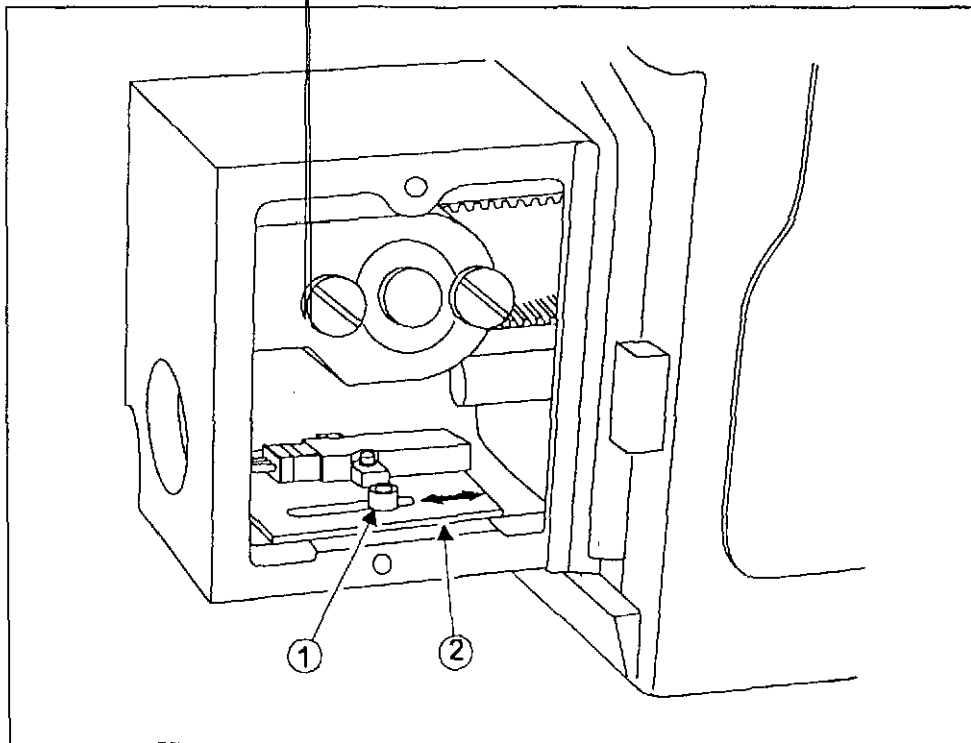

#### 7-15-3. Fine adjustment of the mechanical home position in the X, Y direction

[NOTE] When the original mechanical home position is shifted to the another position or it is required to move a little, a fine adjustment of the mechanical home position in the X, Y direction can be done with the setting panel of the control box. For this fine adjustment, refer to the instructions [1. Program 1 mode display and the function of each key] in the paragraph 9 Basic mode

## 7-16. Adjustment of the X-Y detector clearance

[NOTE] The work holder stop position which is the mechanical home position is detected by the X-Y detectors. If the clearance between the detector and the detector plate is changed, the mechanical home position is also changed. If such aberration is happened, make the following adjustment. Please keep it in mind if the detector senses the home position, the red pilot light of the detector goes on each time.

### 7-16-1. Adjustment of the X detector clearance

- (1) Remove the X detector cover.
- (2) Check the clearance between the surface of the detector and the detector plate. If this clearance is about 1.5~2.5mm, it is the normal condition.
- (3) If this clearance is out of the normal condition, loosen the set screws (NO.①) and move the detector plate, then adjust the clearance to be proper.
- (4) After the adjustment, make the detector surface parallel with the detector plate then, tighten the set screws (NO.①) securely.

### 7-16-2 Adjustment of the Y detector clearance

The clearance between the detector surface and Y-drive shaft is set to 1.5mm.

There is no adjustable space in this clearance.

#### Caution

- ★ If the detector clearance becomes more than 2.5mm, the work holder stop position becomes unstable, furthermore, if the clearance becomes far bigger than 2.5mm the work holder does not stop and becomes out of control.

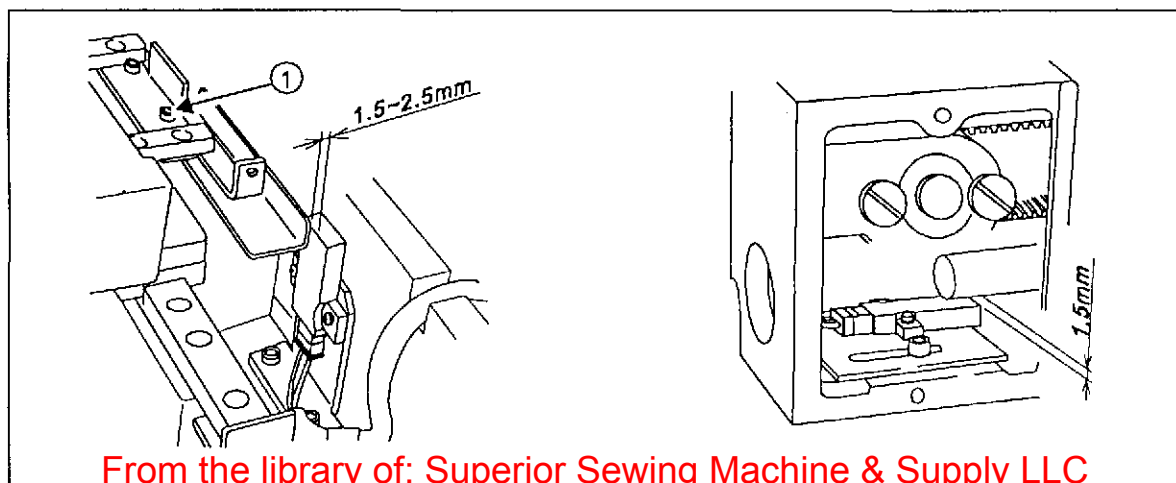

From the library of: Superior Sewing Machine & Supply LLC

## 7-17 Adjustment of the X-Y timing belt tension

[NOTE] The proper condition of the X-Y timing belt tension is standing that they will not be got any yield even it is slightly pushed by hand.

### 7-17-1 Adjustment of the X timing belt tension

- (1) Remove the X-bellow (left) and X-Y cover.
- (2) Loosen the set screws (NO.②)(4 pieces) of the bracket (NO.①).
- (3) If tighten the tension adjust screw (NO.③), the X timing belt (NO.④) tension will be increased.
- (4) After the adjustment, securely tighten the set screw (NO.②) of the bracket (NO.①) and put the X-Y cover and X-bellows on the original locations.

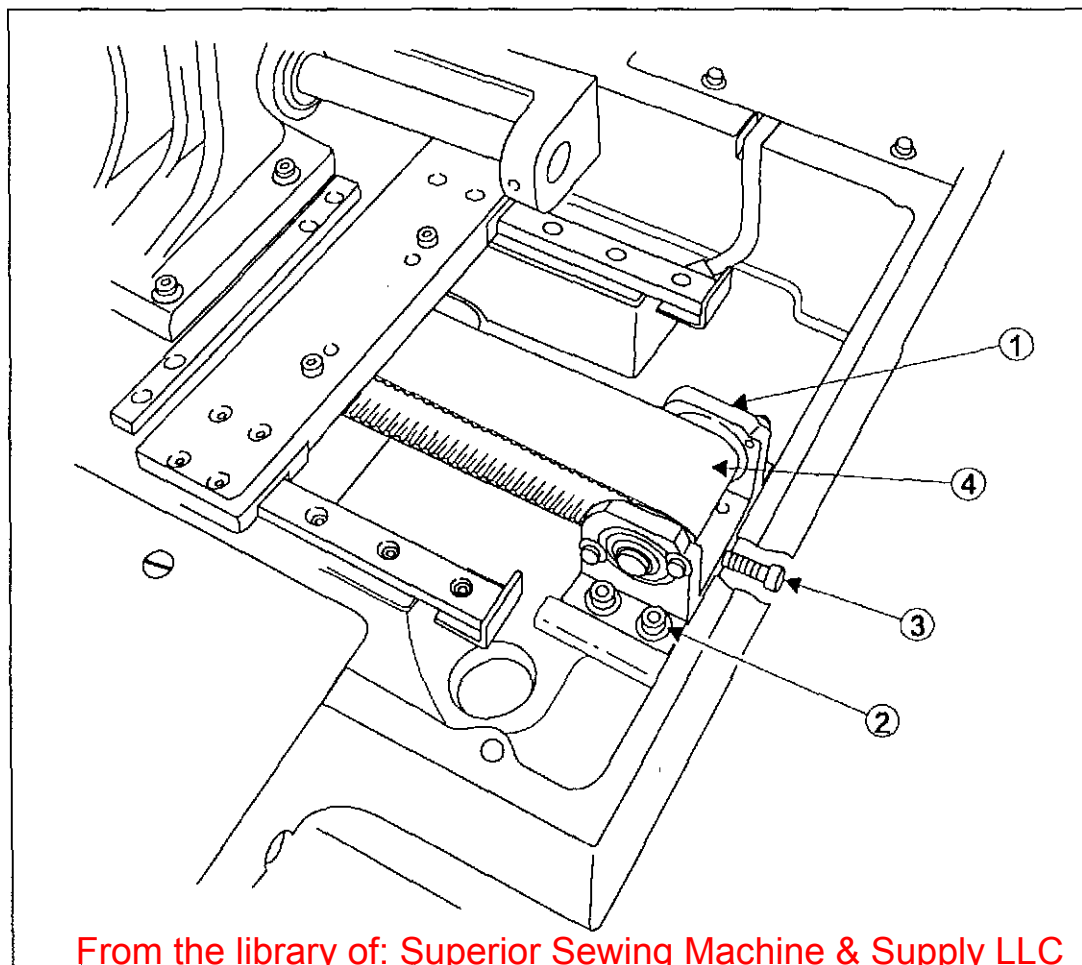



## 7-17-2. Adjustment of the Y timing belt tension

- (1) Loosen set screws(NO.①) of the brackets. (It's located machine arm tail)Also loosen set screw(NO.②) of the bracket.
- (2) If tighten the tension adjust screw (NO.②), the Y timing belt tension will be increased.
- (3) After the adjustment, tighten the set screws(NO.①) securely.

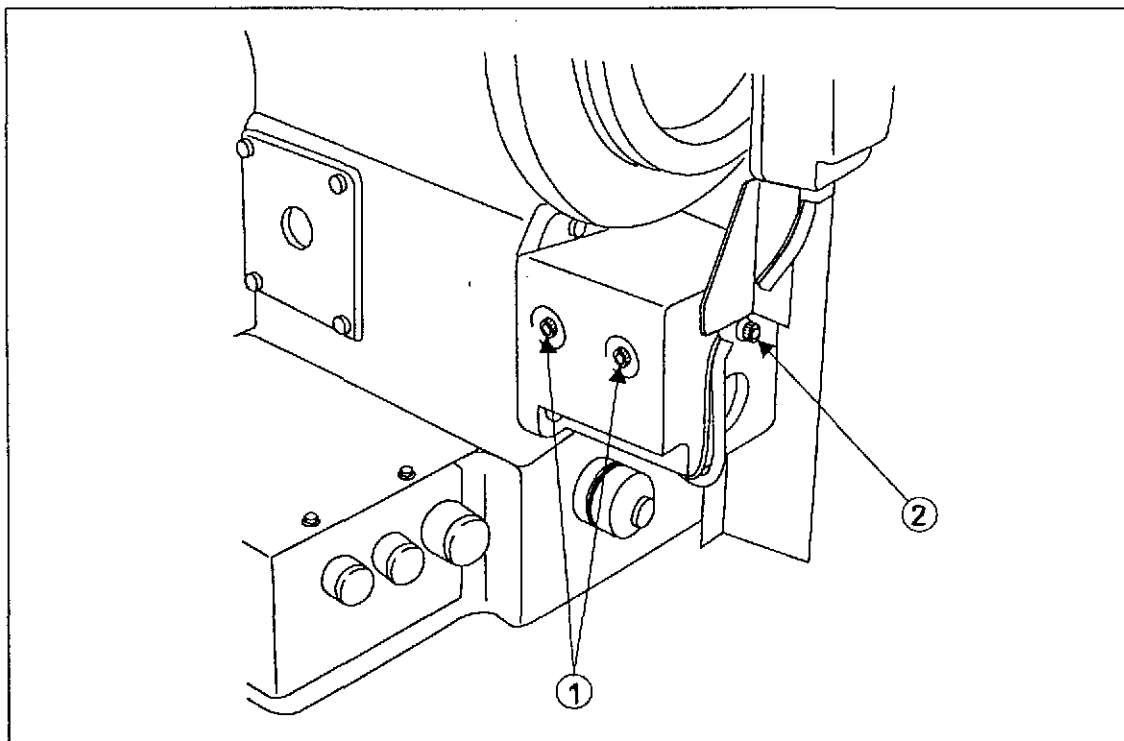

# APPENDIX

## 1 CHART OF CONNECTING WIRES

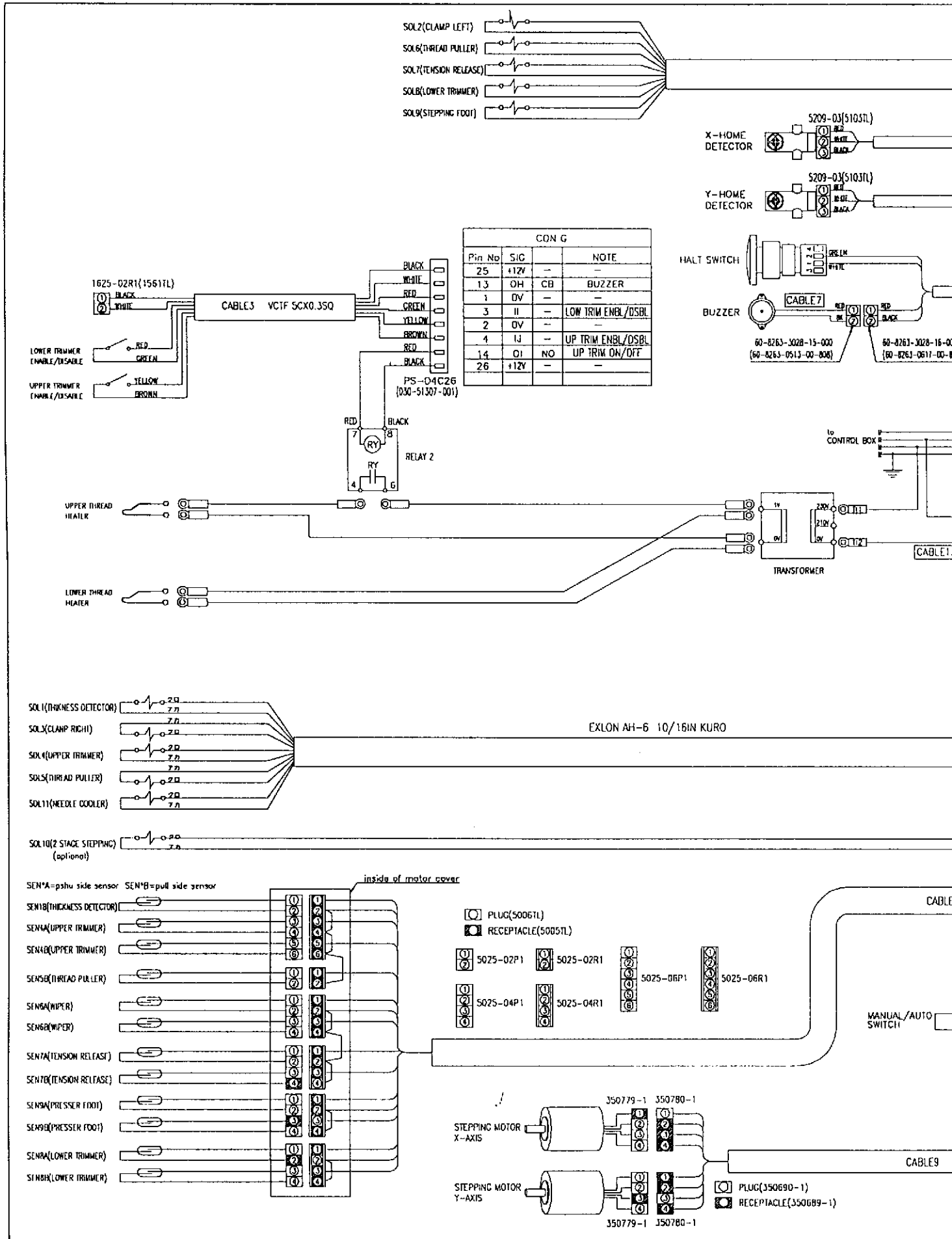

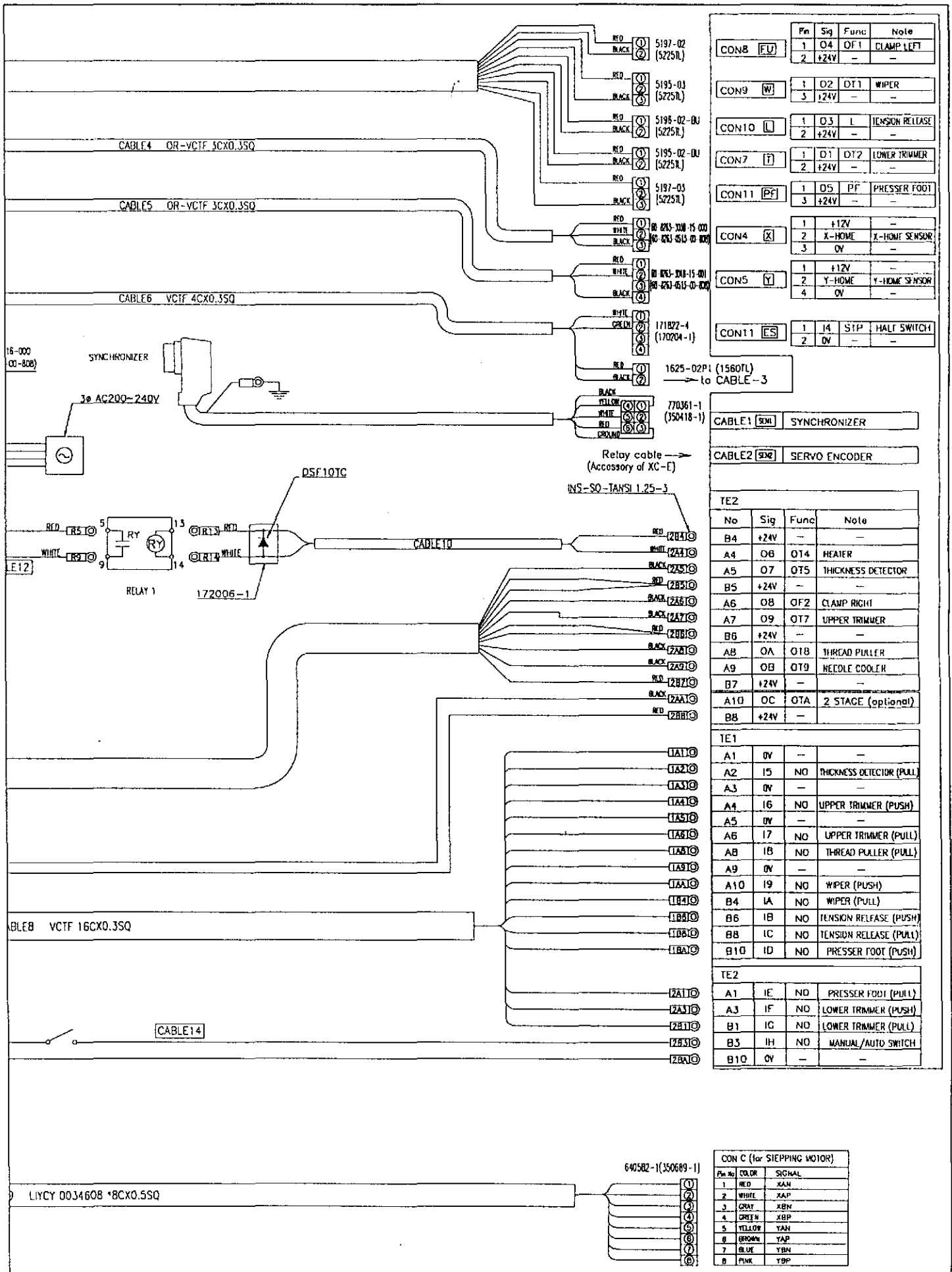

CONB	Fu	Pin No	Sig	Func	Note
FU		1	O4	OF1	CLAMP LEFT
		2	+24V	-	-
CON9	W	1	D2	DT1	WIPER
		2	+24V	-	-
		3	-	-	-
CON10	L	1	D3	L	TENSION RELEASE
		2	+24V	-	-
CON7	F	1	D1	DT2	LOWER TRIMMER
		2	+24V	-	-
CON11	Pf	1	D5	PF	PRESSER FOOT
		2	+24V	-	-
		3	-	-	-
CON4	X	1	+12V	-	-
		2	X-HOME	X-HOME SENSOR	-
		3	OV	-	-
CON5	Y	1	+12V	-	-
		2	Y-HOME	Y-HOME SENSOR	-
		4	OV	-	-
CON11	ES	1	J4	STP	HALT SWITCH
		2	OV	-	-

CABLE 1	SW	SYNCHRONIZER
CABLE 2	SW	SERVO ENCODER

No	Sig	Func	Note
B4	+24V	-	-
A4	O6	OT4	HEATER
A5	O7	OT5	THICKNESS DETECTOR
B5	+24V	-	-
A6	O8	OF2	CLAMP RIGHT
A7	O9	OT7	UPPER TRIMMER
B6	+24V	-	-
AB	OA	OT8	THREAD PULLER
A9	OB	OT9	NEEDLE COOLER
B7	+24V	-	-
A10	OC	OTA	2 STAGE (optional)
B8	+24V	-	-

No	Sig	Func	Note
A1	OV	-	-
A2	I5	NO	THICKNESS DETECTOR (PULL)
A3	OV	-	-
A4	I6	NO	UPPER TRIMMER (PUSH)
A5	OV	-	-
A6	I7	NO	UPPER TRIMMER (PULL)
AB	IB	NO	THREAD PULLER (PULL)
A9	OV	-	-
A10	I9	NO	WIPER (PUSH)
B4	IA	NO	WIPER (PULL)
B6	IB	NO	TENSION RELEASE (PUSH)
BB	IC	NO	TENSION RELEASE (PULL)
B10	ID	NO	PRESSER FOOT (PUSH)

No	Sig	Func	Note
A1	IE	NO	PRESSER FOOT (PULL)
A3	IF	NO	LOWER TRIMMER (PUSH)
B1	IC	NO	LOWER TRIMMER (PULL)
B3	IH	NO	MANUAL/AUTO SWITCH
B10	OV	-	-

Pin No	COLOR	SIGNAL
1	RED	XAN
2	WHITE	XAP
3	GRAY	XBN
4	GREEN	XBP
5	YELLOW	XAN
6	BROWN	YAN
7	BLUE	YBN
8	PINK	YBP

## 2 WIRING BETWEEN THE POWER SWITCH TO RELAY

The cables from 101 to 104 are enclosed in accessory box.

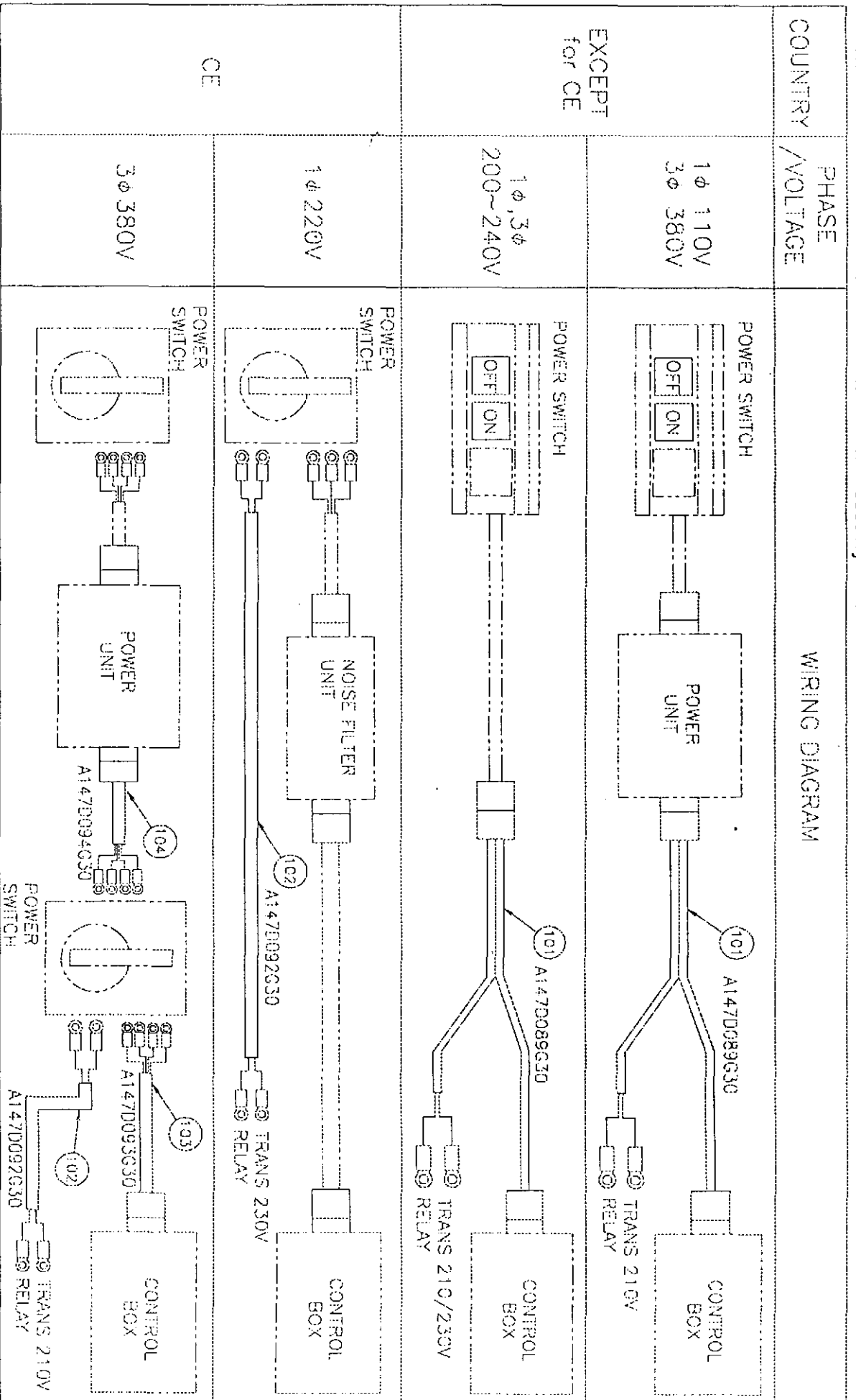

A134C215X01 : 998.05.20



CONVENTIONAL CABLES OR UNITS



SPECIAL CABLES FOR PLK-B100RH

3 PLK-B1008H I/O TABLE

INPUT		
TERMINAL	SIGNAL	FUNCTION
CON I-2	I1	START
CON I-3	I2	CLAMP
CON H-3	I4	STOP
TE1-A2	I5	THICKNESS DETECTOR UP
TE1-A4	I6	UPPER TRIMMER ACT
TE1-A6	I7	UPPER TRIMMER BACK
TE1-A8	I8	UPPER THREAD PULL ACT
TE1-A10	I9	WIPER BACK
TE1B4	IA	WIPER ACT
TE1-B6	IB	TENSION RELEASE BACK
TE1-B8	IC	TENSION RELEASE ACT
TE1-B10	ID	PRESSER FOOT DOWN
TE2-A1	IE	PRESSER FOOT UP
TE2-A3	IF	LOWER TRIMMER ACT
TE2-B1	IG	LOWER TRIMMER BACK
TE2-B3	IH	NORMAL / TEST SWITCH
CON G-3	II	LOWER TRIMMER SWITCH
CON G-4	IJ	UPPER TRIMMER SWITCH

OUTPUT				
TERMINAL	SIGNAL	CUSTOMIZE	FUNCTION	SOL No
CON D-1	O1	OT2	LOWER TRIMMER	8
CON D-9	O2	OT1	WIPER	6
CON D-2	O3	NO	TENSION RELEASE	7
CON D-10	O4	OF1	CLAMP LEFT	2
CON D-3	O5	OTA	PRESSER FOOT	9
TE2-A4	O6	OT4	HEATER	-
TE2-A5	O7	OT5	THICKNESS DETECTOR	1
TE2-A6	O8	OF2	CLAMP RIGHT	3
TE2-A7	O9	OT7	UPPER TRIMMER	4
TE2-A8	OA	OT8	THREAD PULLER	5
TE2-A9	OB	DRT	NEADLE COOLER	10
CON G-13	OH	OTB	BUZZER	-

### 4 TRIMMING TIME CHART

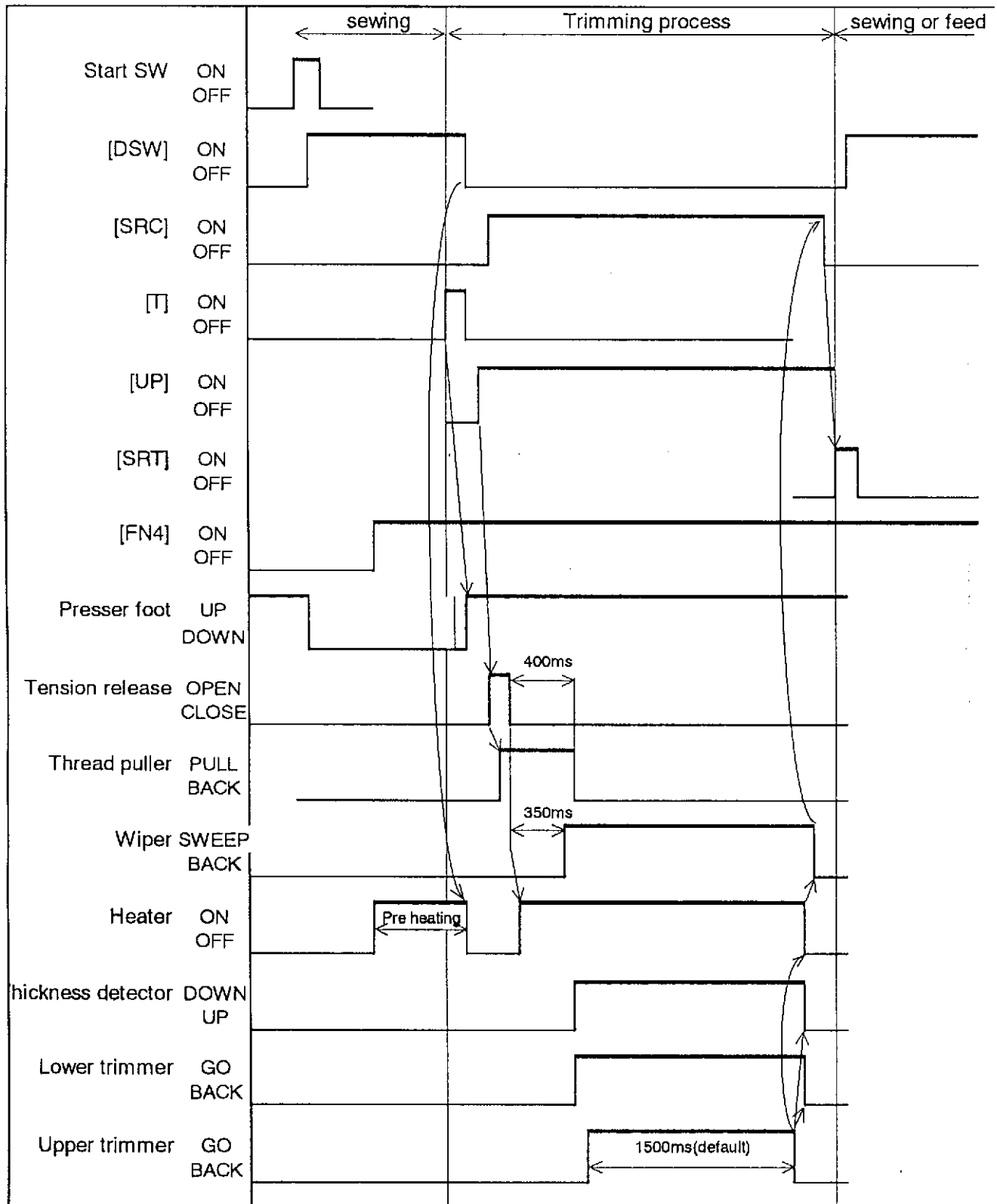

- [DSW] : Sewing in progress output signal (by system)
- [SRC] : Start prohibit input signal (by step sequence)
- [T] : Thread trimming output signal (output by teaching data)
- [UP] : Up position output signal (by system)
- [SRT] : Start input signal (output by teaching data)
- [FN4] : Function No.4 output signal (output by teaching data)

[Heater protection] : In the trimming process, heater is automatically off after 2.5 sec inspite of trimming process is end or not.

:In any time, heater can be off by pressing the halt switch.