

三菱工業用ミシン部品カタログ

Industrial Sewing Machine Parts Catalog

Model LY2-3319

目次	CONTENTS	Page
A 本体関係	Arm bed & it's accessories	2
B 縫機構 (I)	Sewing mechanism (I)	4
C 縫機構 (II) および下送り機構	Sewing mechanism (II) & feed rock lower shaft mechanism	6
D 送り調節機構	Stitch length mechanism	8
E 上部水平送り機構	Upper feed rock shaft mechanism	10
F 上部上下送り機構	Upper feed lifting rock shaft mechanism	12
G 押え機構	Presser foot mechanism	14
H 糸切り機構	Knife actuating mechanism	16
J タッチバック機構および検出器機構	Touch back mechanism & detector mechanism	18
K 給油機構	Oil lubrication mechanism	20
L 付属品	Accessories	22
M 索引	Index	24

ミシン用部品コードの採番基準 MITSUBISHI SPARE PARTS No. Designation system

注：※欄には英文字(A,B,...X,Y,Z)が入る。
Remarks : Alphabet(A,B,...X,Y,Z) should be taken at
※ mark.

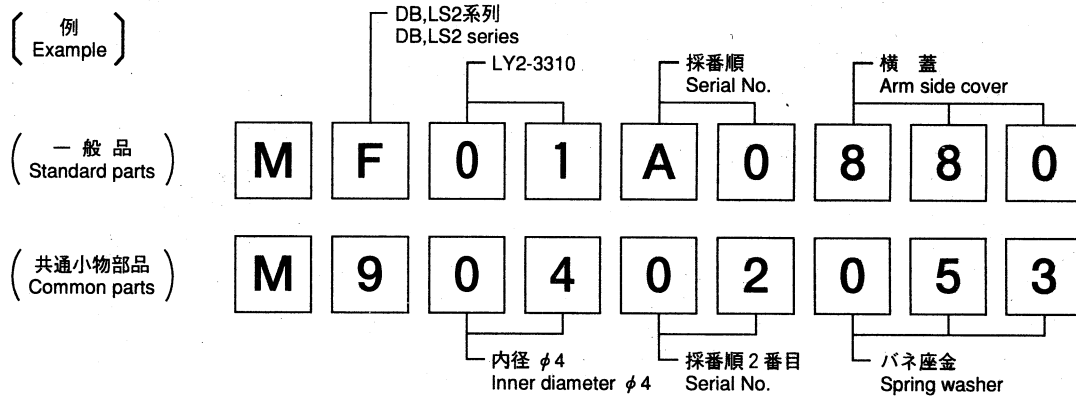
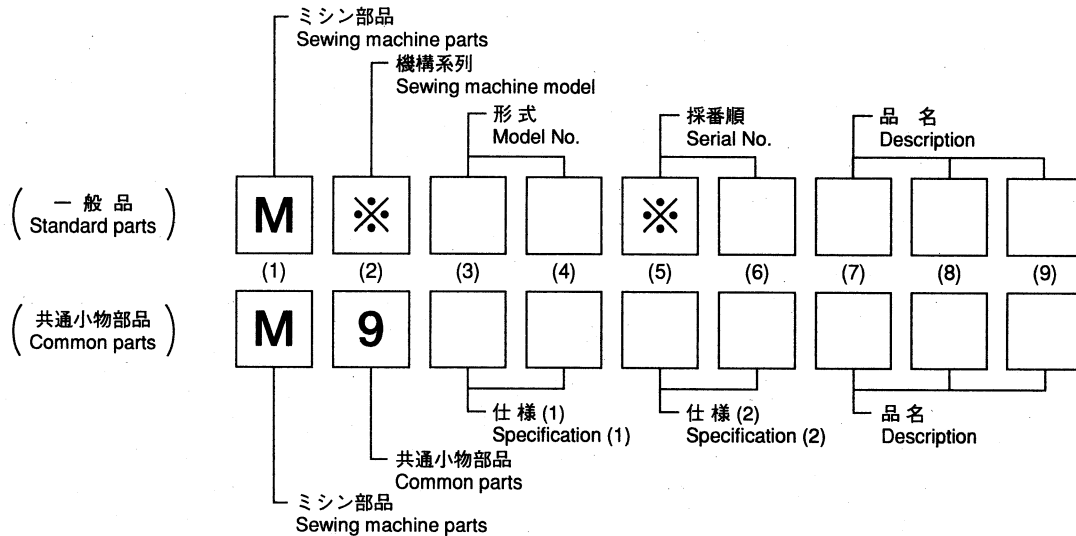

注：一般品についての機種形名は、その部品が最初に使用された機種形名を示します。従って長期に亘る場合は、機種の変更が行われるため、当初の機種以外の機種で使用されている場合があります。
Sewing machine Models, of Standard Parts are indicated model of these parts are registered firstly. Parts are used for not only the indicated model, but also another models, in reason of New development, improvement after.

パーツカタログご利用に際して Information on use of the parts catalog

- ・ 補用部品ご注文の際は、部品コードでご注文下さい。また、このパーツブックの管理番号と発行年月（表紙右下、例えば、P-216 200106）モデル機械番号を、合わせてご連絡頂ければ幸いです。
- ・ 一部の部品について、改良のため予告なしに変更になる場合がありますのでご了承下さい。
- ・ このパーツカタログは2001年6月のデータにもとづいて作成されたものです。
- ・ 部品コード欄が、—となっている部品は、補給いたしません。ただし組コードが記載されているものは、組部品として補給いたしますので、組コードでご注文下さい。
- ・ 使用個数欄の英数字組合せ文字は、このモデル番号のサブ機械番号をしめています。
- ・ 尚、本パーツブックの記載内容にお気付きの点がありましたら、お知らせ頂ければ幸いです。

- ・ When ordering any spare part, please specify its part code. In addition, please specify the management number and issued date of this parts catalog (e. g. P-216 200106 indicated at bottom right of the front cover) and the machine model number.
- ・ Some parts are subject to change due to modification without notice.
- ・ This parts catalog is based the data as of Jun.2001.
- ・ Any part marked-in the part code column will not be supplied. When a part has its assembly code, please specify the assembly code because that part is supplied as an assembly part.
- ・ Alphanumerical characters indicated in the required quantity column indicate the sub machine number of this model number.
- ・ Please write to us if you have any question on this parts catalog.

A 本体機構
ARM BED & IT'S ACCESSORIES

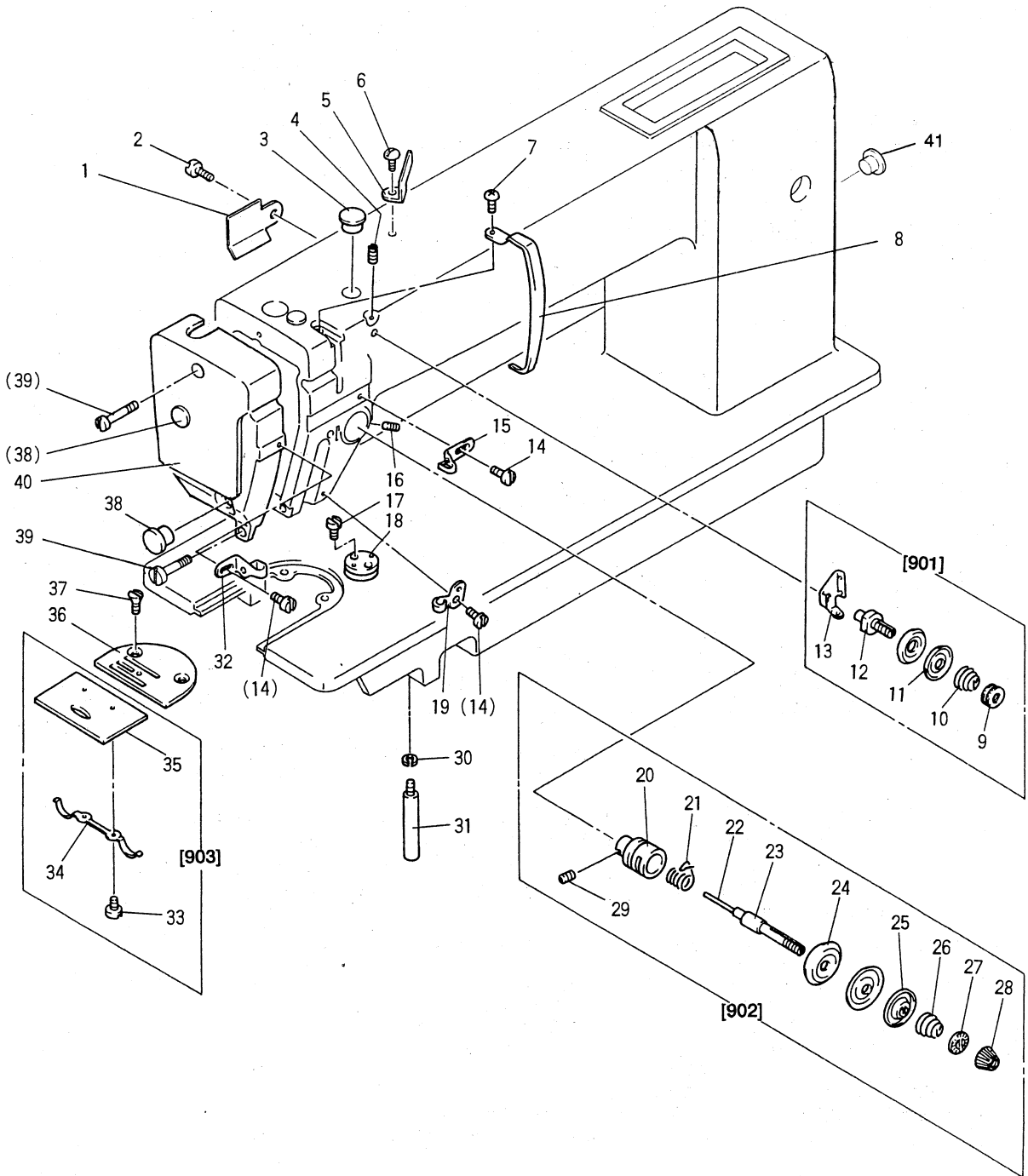

A 本体機構

ARM BED & IT'S ACCESSORIES

Fig.	変更	部品コード	部品名	Description	使用数
No.	Mod	Parts.No.			Amt. Reg.
A01		MG33A0873	オイルシールドプレート	Oil shield plate	1
A02		M91109004	11/64(40)x8ネジ	Screw 11/64(40)x8	1
A03		M91305080	13番ラバープラグ	Rubber plug 13	1
A04		M91108001	11/64(40)x5.5セットネジ	Set screw 11/64(40)x5.5	1
A05		MF36A1180	アームトップのガイドスレッド	Thread guide (arm top)	1
A06		M91116002	11/64(40)x8ネジ	Screw 11/64(40)x8	1
A07		M91106004	11/64(40)x8ネジ	Screw 11/64(40)x8	1
A08		MF03A0584	スレッド取り出しカバー	Thread take-up cover	1
A09		M91101046	11/64(40)プレテンション調整ナット	Pre-tension adjusting nut 11/64(40)	1
A10		MF36A0245	プレテンションスプリング	Pre-tension spring	1
A11		MF10A1555	プレテンションディスク	Tension discs for pre-tension	2
A12		MF90A0553	プレテンションスタッド	Pre-tension stud	1
A13		MF00A0181	アームトップのガイドスレッド	Thread guide	1
A14		M90909003	9/64(40)x6ネジ	Screw 9/64(40)x6	3
A15		MG43A0181	アームトップのガイドスレッド	Thread guide	1
A16		M91508001	15/64(28)x6セットネジ	Set screw 15/64(28)x6	1
A17		M91107002	11/64(40)x5.5ネジ	Screw 11/64(40)x5.5	2
A18		MG30A0601	布ガイドプレート	Cloth guide plate	1
A19		MG50A0181	アームトップのガイドスレッド	Thread guide	1
A20		MF10A0709	スレッドテンション調整バッシング	Thread tension regulator bushing	1
A21		MF02A0187	スレッド取り出しスプリング	Thread take-up spring	1
A22		M90204060	2x28.4スレッドテンションリリースピン	Thread tension releasing pin ϕ 2x28.4	1
A23		MF02A0553	スレッドテンションスタッド	Thread tension stud	1
A24		MF10A0555	スレッドテンションディスク	Thread tension discs	2
A25		MM11A0556	スレッドテンションリリースディスク	Thread tension releasing discs	1
A26		MG52A0245	スレッドテンションスプリング	Thread tension spring	1
A27		MT60A0802	サムナット	Thumb nut revolution stopper	1
A28		M91605045	1/4(40)サムナット	Thumb nut 1/4(40)	1
A29		M90901002	9/64(40)x4ネジ	Screw 9/64(40)x4	1
A30		M90625053	6番脚用スプリングワッシャー	Spring washer for leg 6	1
A31		MG33A0426	脚	Leg	1
A32		MG43A1181	アームトップのガイドスレッド	Thread guide	1
A33		M90604002	3/32(56)x2.2ネジ	Screw 3/32(56)x2.2	2
A34		MF10A0471	スライドプレート用スプリング	Spring for slide plate	1
A35		—	スライドプレート	Slide plate	1
A36		MF26B0101	針プレート (B2.6)	Needle plate (B2.6)	1
A37		M91102011	11/64(40)x8.5ネジ	Screw 11/64(40)x8.5	2
A38		M91182080	11.8φラバープラグ	Rubber plug ϕ 11.8	2
A39		M91106003	11/64(40)x20ネジ	Screw 11/64(40)x20	2
A40		MG35A1830	フェイスプレート	Face plate	1
A41		M90901080	9.6φラバープラグ	Rubber plug ϕ 9.6	1
A901		MF00E0550	プレテンションアッセンブリ	Pre-tension assy.	1
A902		MG34E0210	スレッドテンション調整機構	Thread tension regulator complete	1
A903		MG75E0470	スライドプレート機構	Slide plate complete	1

B 縫機構 (I)
SEWING MECHANISM (I)

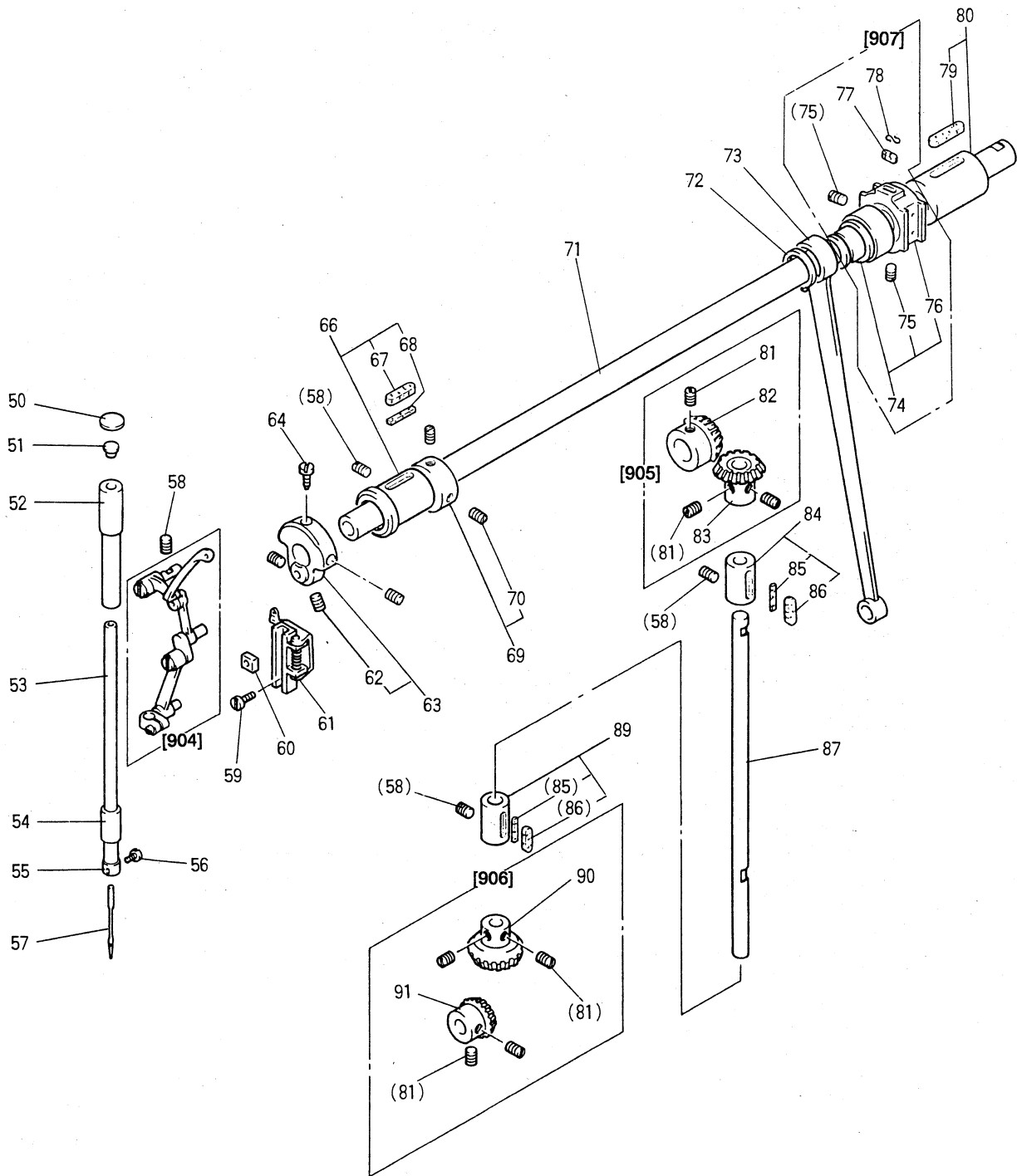

B 縫機構 (I)

SEWING MECHANISM (I)

Fig. 変更 部品コード				使用数
No.	Mod	Parts.No.	部 品 名	Amt. Reg.
				BIT
B50		MF60A0742	フタ.....	Cap for needle bar bushing(upper)..... 1
B51		MF10A2740	フェルト.....	Felt for needle bar bushing(upper)..... 1
B52		MF60A0663	ハリホ ^ウ メタルウエ.....	Needle bar bushing(upper)..... 1
B53		MG50A0660	ハリホ ^ウ	Needle bar..... 1
B54		MF20A0664	ハリホ ^ウ メタルシタ.....	Needle bar bushing(under)..... 1
B55		MG42A0181	イトアソナイ.....	Tread guide for needle bar..... 1
B56		M90815002	ヒラネジ.....	Screw 1/8(44)x4.5..... 1
B57		MG37A0128	ミシンハリ DPX17-22.....	Needle DPX17#22..... 1
B58		M91513001	トメネジ.....	Set screw 15/64(28)x10..... 4
B59		M91106004	フ ^ラ マイネジ.....	Screw 11/64(40)x8..... 2
B60		MF30A0325	カクコマ.....	Square block..... 1
B61		MG44E0662	ハリカ ^{イト} クミタテ.....	Needle bar connecting link guide assy..... 1
B62		M91606001	トメネジ.....	Set screw 1/4(40)x6..... 3
B63		MF60A1383	クランククミタテ.....	Crank assy..... 1
B64		M91802006	ヒラネジ ^ホ ウサキ.....	Screw 9/32(28)x14..... 1
B66		MF60A0232	ウヅ ^ク メタルヒタ ^リ クミタテ.....	Bushing for arm shaft(left)..... 1
B67		MV88A0740	フェルト.....	Felt..... 1
B68		MG50A0740	フェルト.....	Felt..... 1
B69		MF80A0352	カ ^ラ クミタテ.....	Collar for arm shaft assy..... 1
B70		M91602001	トメネジ.....	Set screw 1/4(40)x4..... 2
B71		MG36A0230	ウヅ ^ク	Arm shaft..... 1
B72		M90320065	C ^カ タ ^ト メワジ ^ク ヨウ 20.....	C-type stop ling 20..... 1
B73		MG33A0384	レンセツカン.....	Crank rod assy..... 1
B74		MF30E0280	ヘンシンリンクミタテ.....	Upper feed lifting cam..... 1
B75		M91506001	トメネジ.....	Set screw 15/64(28)x7..... 2
B76		MG34A0325	カクコマ.....	Square block..... 1
B77		MF60A1740	フェルト.....	Felt..... 1
B78		MF60A0700	センサイクハ ^ネ	Spring for feed cam..... 1
B79		MF60A2740	フェルト.....	Felt..... 1
B80		MG33A0233	ウヅ ^ク メタルミキ ^ク ミタテ.....	Bushing for arm shaft(right)..... 1
B81		M91610001	トメネジ.....	Set screw 1/4(40)x7..... 8
B82		MF40A0331	ウヅ ^ク カサハ ^ク ルマ.....	Bevel gear for arm shaft..... 1
B83		MF40A0333	タテ ^ク カサハ ^ク ルマウエ.....	Bevel gear for vertical shaft(upper)..... 1
B84		MQ70A0521	タテ ^ク メタルクミタテ.....	Vertical shaft bushing assy..... 1
B85		MQ50A0148	ヒモ.....	Oil wick..... 2
B86		MF60A0740	フェルト.....	Felt..... 2
B87		MG50A0520	タテ ^ク	Vertical shaft..... 1
B89		MF67B0522	タテ ^ク メタルクミタテ.....	Vertical shaft bushing assy..... 1
B90		MF10A0332	タテ ^ク カサハ ^ク ルマシタ.....	Bevel gear for vertical shaft(lower)..... 1
B91		MF40A0332	シタ ^ク カサハ ^ク ルマ.....	Bevel gear for hook shaft..... 1
B904		MG40E0580	テンピ ^ン ハリククミタテ.....	Thread take-up lever assy..... 1
B905		MF01E0331	カサハ ^ク ルマクミタテ.....	Bevel gear for arm shaft..... 1
B906		MF01E0332	カサハ ^ク ルマクミタテ.....	Bevel gear for arm shaft..... 1
B907		MG33E0760	ヘンシンリンクミタテ.....	Upper feed lifting cam..... 1

C
 縫機構 (Ⅱ) および下送り機構
 SEWING MECHANISM (Ⅱ) & FEED ROCK LOWER SHAFT MECHANISM

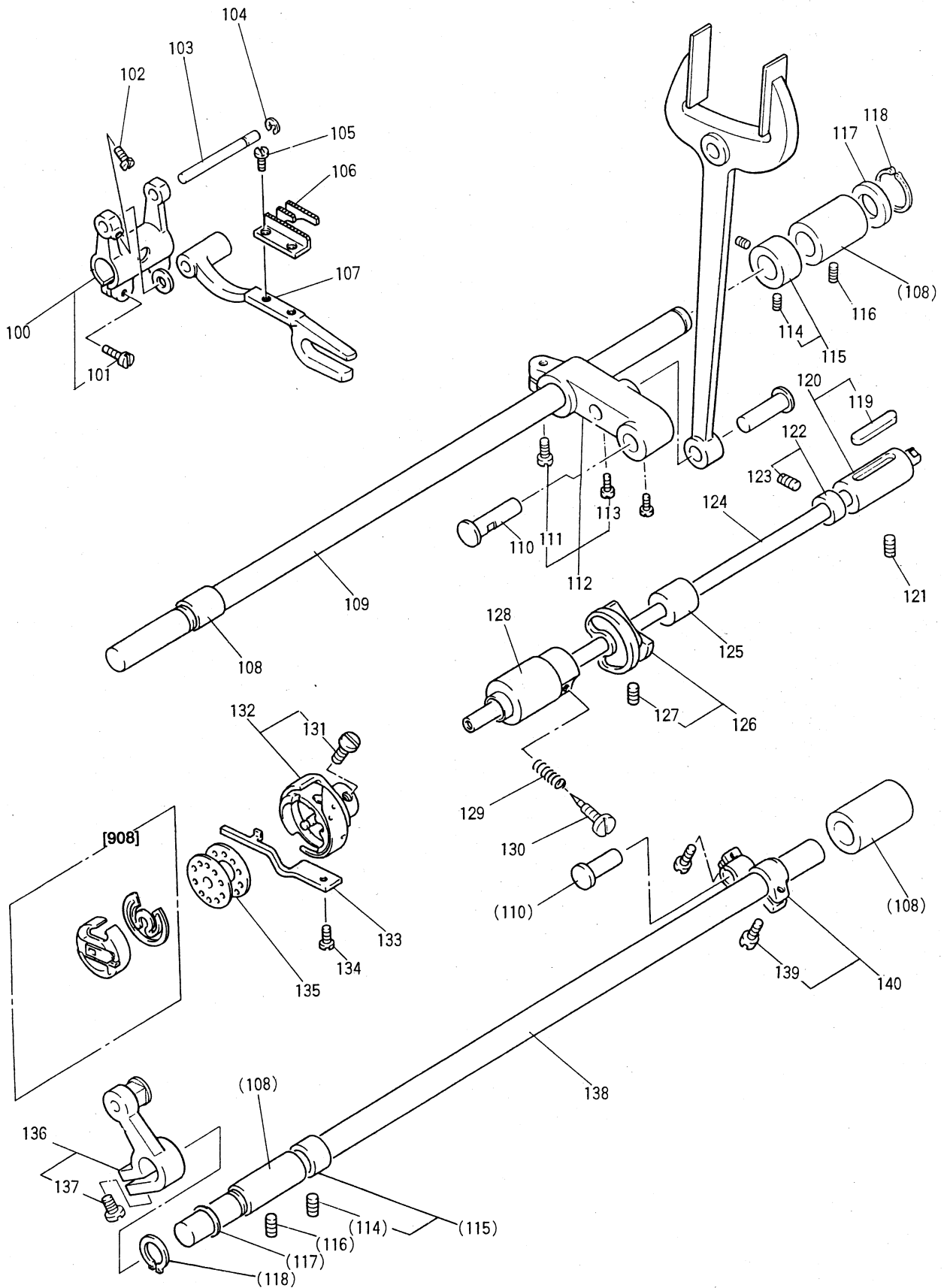

C 縫機構 (II) および下送り機構

SEWING MECHANISM (II) & FEED ROCK LOWER SHAFT MECHANISM

Fig. 変更 部品コード				使用数	
No.	Mod	Parts.No.	部 品 名	Amt. Reg.	
				B/T	
C100		MG30A0278	スィイオクリウテヒダリクミタテ	Feed rock shaft crank (left) assy.	1
C101		M91203002	ヒラネジ	Screw 3/16 (28) x15	2
C102		M91106004	ブライネジ	Screw 11/64 (40) x8	2
C103		MG33A0283	オクリダ イサエジク	Feed bar holder stud	1
C104		M70535065	Eガトメワ 5	E-type stop ring 5	1
C105		M90806002	ヒラネジ	Screw 1/8 (44) x6	2
C106		MF10A0104	オクリ	Feed dog	1
C107		MG33A0281	オクリダ イ	Feed bar	1
C108		MG33A0285	オクリジクメタル	Feed rock shaft bushing	4
C109		MG36A0284	オクリジク	Feed rock shaft	1
C110		M90904060	ピン	Pin	3
C111		M91603003	マルヒラネジ	Screw 1/4 (24) x16	1
C112		MG35E0306	オクリクドウウテクミタテ	Feed lifting & rock shaft crank assy.	1
C113		M91516002	ヒラネジ	Screw 15/64 (28) x8.5	2
C114		M91602001	トメネジ	Set screw 1/4 (40) x4	4
C115		MF80A0352	カークミタテ	Collar for arm shaft assy.	2
C116		M91513001	トメネジ	Set screw 15/64 (28) x10	2
C117		M91502050	ザガネ	Washer ϕ 20.5	2
C118		M90315065	Cガトメワ シクヨウ 15	C-type stop ling 15	2
C119		MF60A0740	フェルト	Felt	1
C120		MG37B0452	シタジクメタルミギクミタテ	Rotating hook shaft bushing (right) assy.	1
C121		M91110001	トメネジ	Set screw 11/64 (40) x8.5	1
C122		MF30A0352	カークミタテ	Thrust collar	1
C123		M91503001	トメネジ	Set screw 15/64 (28) x4.5	2
C124		MG36A0450	シタジク	Rotating hook shaft	1
C125		MF00A0453	シタジクメタルナカ	Lower shaft bushing (middle)	1
C126		MF00A0350	イトキリカムクミタテ	Thread trimmer cam assy.	1
C127		M91602020	ソツカクアナツキトメネジ	Soket set screw 1/4 (40) x10	2
C128		MG50A0451	シタジクメタルヒダリクミタテ	Rotating hook shaft bushing (left)	1
C129		MG30A0700	ツルマキハネ	Spring	1
C130		M90801006	ヒラネジボウサキ	Screw M3x0.35x9.5	1
C132		MG75A0120	カマクミタテ	Rotating hook complete	1
C133		MF20A0229	ウチガトメ	Rotating hook positioner	1
C134		M91118002	ヒラネジ	Screw 11/64 (40) x10	1
C135		MF25B0123	ボビン	Bobbin	1
C136		MF70E0276	ジヨウゲオクリウテヒダリクミタテ	Feed lifting rock shaft crank (left) assy.	1
C137		M91112002	ヒラネジ	Screw 11/64 (40) x12	1
C138		MG36A1284	オクリジク	Feed lifting rock shaft	1
C139		M91204003	マルヒラネジ	Screw 3/16 (28) x12	2
C140		MF70A0277	ジヨウゲオクリウテミギクミタテ	Feed lifting rock shaft crank (right) assy.	1
C908		MF25E1125	ボビンケース	Bobbin case complete	1

D 送り調節機構
STITCH LENGTH MECHANISM

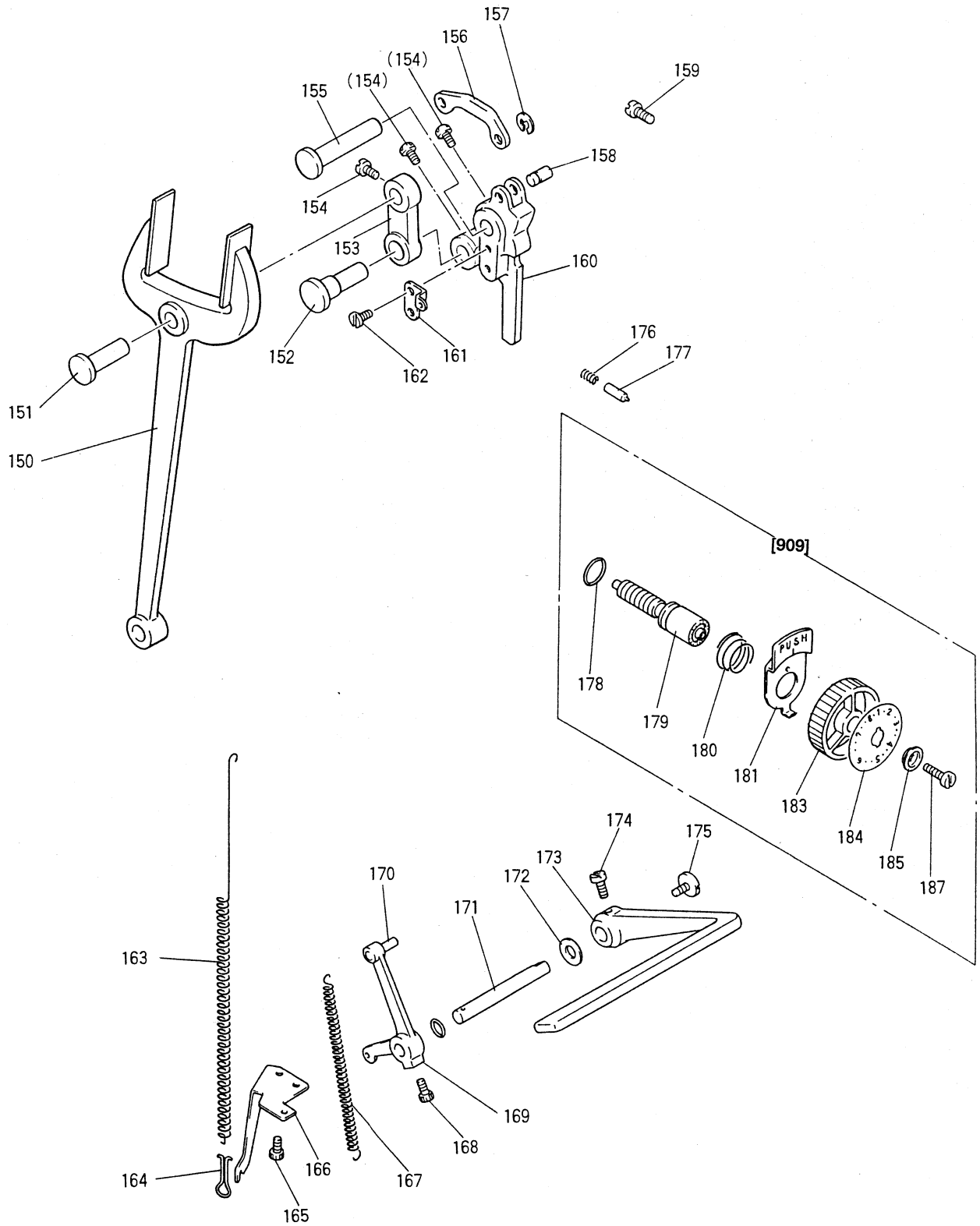

D 送り調節機構

STITCH LENGTH MECHANISM

Fig.	変更	部品コード	部品名	Description	使用数
No.	Mod	Parts. No.			Amt. Reg.
D150		MG33A0744	フタマロット	Feed forked connecting rod	1
D151		M90720063	ダンツキジク	Set pin	1
D152		MG33A0761	ヘンシンジク	Eccentric pin	1
D153		MG33A0910	リンク	Link	1
D154		M91516002	ヒラネジ	Screw 15/64(28)x8.5	3
D155		MG33A0530	ダンツキジク	Set pin	1
D156		MF00A1910	リンク	Link	1
D157		M70534065	Eカトメワ 4	E-type stop ring 4	1
D158		M90534060	ピン	Pin ϕ 5.5	1
D159		M91502002	ヒラネジ	Set screw 15/64(28)x12	1
D160		MG34A0291	オクリチヨウセツカム	Feed regulator	1
D161		MF40A2708	カケガネ	Spring holder	1
D162		M91110002	ヒラネジ	Screw 11/64(40)x8	2
D163		MG50A0572	ツルマキバネ	Spring	1
D164		MN15A0708	カケガネ	Spring holder	1
D165		M91106004	プ ラマイネジ	Screw 11/64(40)x8	2
D166		MG34A0708	バネカケイタ	Spring holder	1
D167		MF10A0572	ツルマキバネ	Spring	1
D168		M91501007	マルヒラネジホウサキ	Screw 15/64(28)x14.5	1
D169		MF60A0634	ヌイメカゲンウデ	Stitch length regulator	1
D170		MG34A0530	ダンツキジク	Set pin	1
D171		MF60A0633	ヌイメカゲンジク	Reverse stitch lever shaft	1
D172		M95003053	バネザガネ	Spring washer	1
D173		MF30A0632	ヌイメカゲンレバ	Reverse swing lever	1
D174		M91515002	ヒラネジ	Screw 15/64(28)x10	2
D175		M91207003	マルヒラネジ	Screw 3/16(28)x6.5	1
D176		MF05A0572	ツルマキバネ	Spring	1
D177		MF06A0852	ピン	Stopper pin	1
D178		M91000085	Oリング 1AP10A	O-ring ϕ 10 1AP10A	1
D179		MF85A0640	オクリチヨウセツネジ	Stitch length regulator screw	1
D180		MF02A0245	エンスイバネ	Coil spring	1
D181		MF06A0950	レバ	Releasing lever	1
D183		MF06A1631	ダイヤル	Dial for stitch length regulator	1
D184		MG75A0841	メモリイタ	Stitch length indicating plate	1
D185		MF00A0257	オサエガネ	Bushing	1
D187		M71216002	ヒラネジ	Screw 3/16(28)x18	1
D909		MG34E0640	オクリチヨウセツネジクミタテ	Screw bar assy.	1

E 上部水平送り機構
UPPER FEED ROCK SHAFT MECHANISM

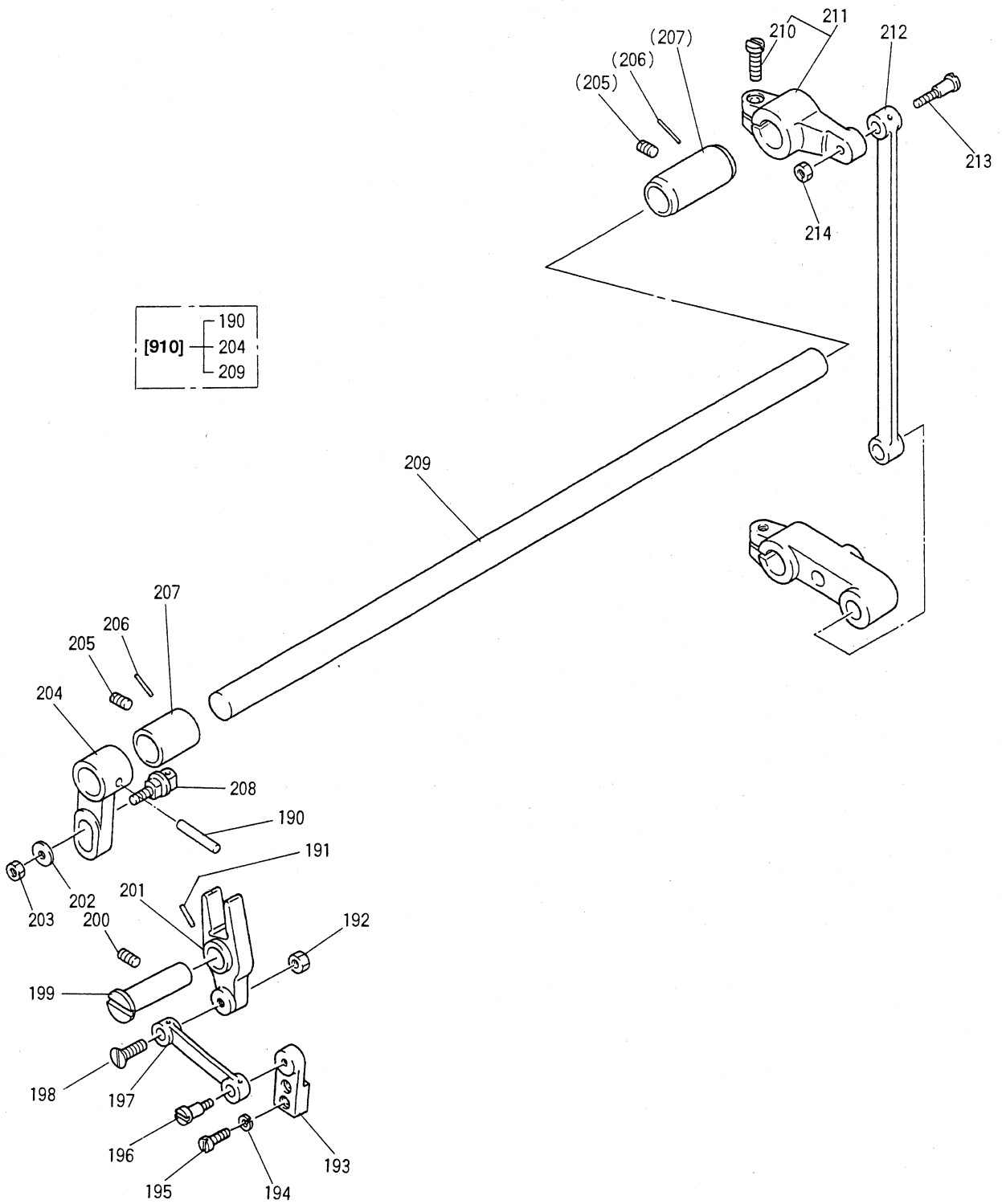

E 上部水平送り機構

UPPER FEED ROCK SHAFT MECHANISM

Fig. 変更		部品コード	部品名	Description	使用数
No.	Mod	Parts. No.			Amt. Reg.
E190		M90401061	テーパピン	Taper pin	1
E191		MV88A0740	フェルト	Felt	1
E192		M91620045	ナット	Nut 1/4(40)	1
E193		MG33A0602	トリツカガネ	Feed arm	1
E194		M90304053	バネザガネ 3.5	Spring washer 3.5	2
E195		M90910003	マルヒラネジ	Screw 9/64(40)x7	2
E196		M91615015	ヒラネジ タンツキ	Hinged screw 1/4(40)x12	1
E197		MG30A0910	レンセツカン	Walking foot connecting link	1
E198		M91601036	テーパアタマネジ	Screw	1
E199		MG30A0530	タンツキジク	Hinged pin	1
E200		M91506001	トメネジ	Set screw 15/64(28)x7	1
E201		MG33A0950	ヘンカンレバー	Feed connecting lever	1
E202		M90601050	ミガキザガネ 6	Washer 6	1
E203		M91604045	ナット	Nut 1/4(24)	1
E204		MG30B0464	ジヨウブスライウテヒタリ	Feed griving rock shaft crank(left)	1
E205		M91108001	トメネジ	Set screw 11/64(40)x5.5	2
E206		MG50A1740	フェルト	Felt	2
E207		MG33A1285	オクリシクメタル	Feed driving shaft bushing	2
E208		MG30E0410	コロサエシクミタテ	Feed connecting slick block complete	1
E209		MG36A0467	ジヨウブスライシク	Feed driving shaft (upper)	1
E210		M91603003	マルヒラネジ	Screw 1/4(24)x16	1
E211		MG30E0465	ジヨウブスライウテミキクミタテ	Feed driving rock shaft crank (right)assy.	1
E212		MG30B0954	レンセツカン	Feed driving connecting link	1
E213		M91803015	ヒラネジ タンツキ	Hinged screw 9/32(28)x26.1	1
E214		M91802045	ナット	Nut 9/32(28)	1
E910		MG36E0467	ジヨウブスライオクリシクミタテ	Feed driving shaft complete	1

F 上部上下送り機構
UPPER FEED LIFTING ROCK SHAFT MECHANISM

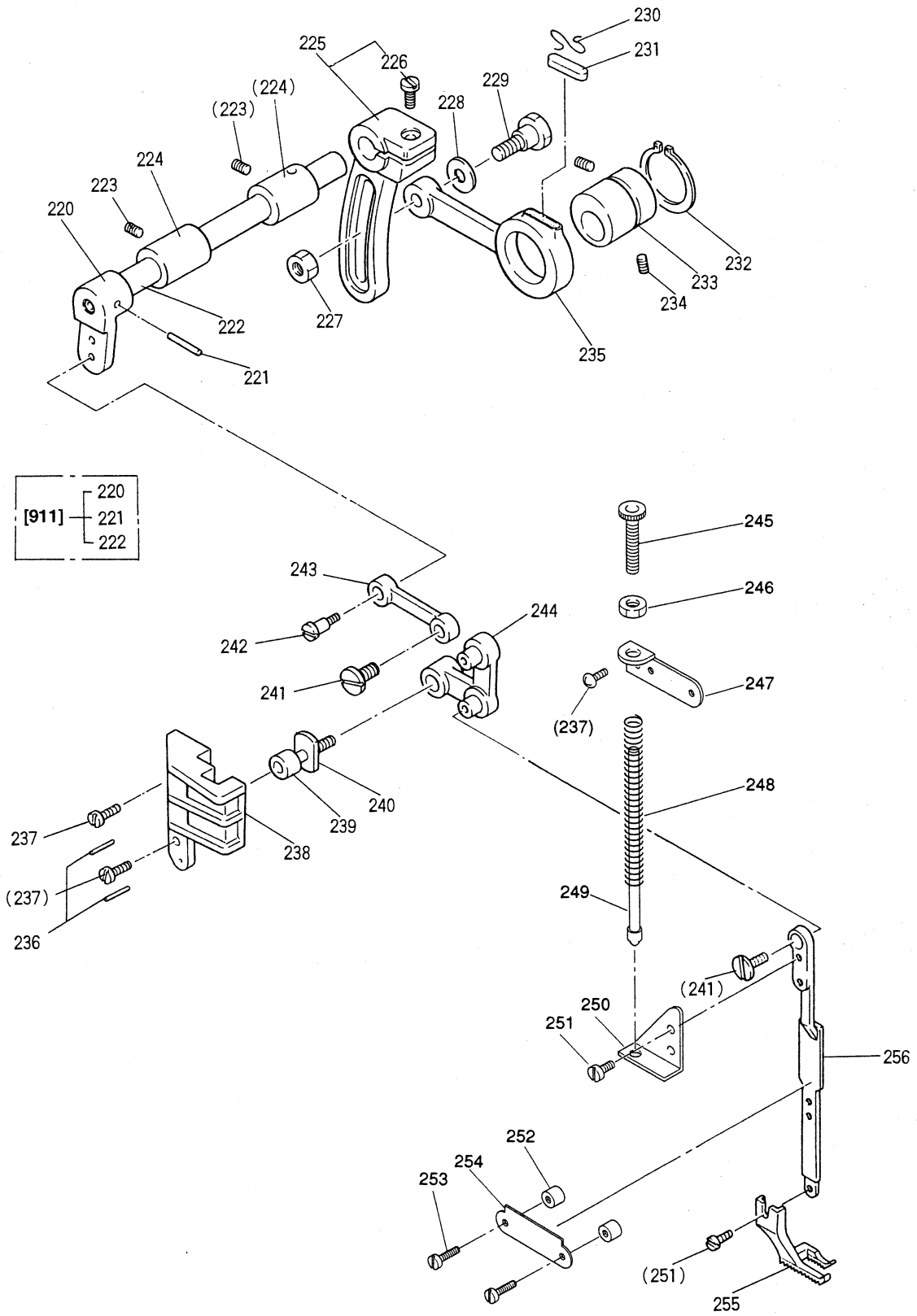

F 上部上下送り機構

UPPER FEED LIFTING ROCK SHAFT MECHANISM

Fig.	変更	部品コード	部品名	Description	使用数
No.	Mod	Parts. No.			Amt. Reg.
F220		MG33A0462	シヨウブジヨウゲウテヒダリ	Upper feed lifting rock shaft crank	1
F221		M90207061	テーパーピン 4X20	Taper pin 4X20	1
F222		MG30A0460	シヨウブジヨウゲシク	Feed lifting rock shaft	1
F223		M91108001	トメネジ	Set screw 11/64(40)X5.5	2
F224		MG33A0833	シヨウブジヨウゲメタル	Feed lifting rock shaft bushing	2
F225		MG30A0463	シヨウブジヨウゲウテミキクミタテ	Feed lifting rock shaft crank(right)assy.	1
F226		M91603003	マルヒラネジ	Screw 1/4(24)X16	1
F227		M91572045	Uナット 6X0.75	U-nut 6x0.75	1
F228		M90601050	ミガキサガネ 6	Washer 6	1
F229		M91551015	トクシホルト	Hinged screw M6X24	1
F230		MF60A0700	センサイカハネ	Spring for felt stopper	1
F231		MG30B0740	フェルト	Felt	1
F232		M90325065	C型外周止クワイ 25	C-type stop ring 25	1
F233		MG30A0760	ヘンシンリン	Feed lifting eccentric	1
F234		M91606001	トメネジ	Set screw 1/4(40)x6	2
F235		MG33A0956	レンセツカン	Feed connecting crank rod	1
F236		M90301064	スプリングピン 3X8	Spring pin 3X8	2
F237		M91106004	ブラマイネジ	Screw 11/64(40)X8	4
F238		MG33A0765	ベルクランクガイド	Bell crank guide bracket	1
F239		MG10B0411	コロ	Bell crank guide bracket block	1
F240		M90507063	ササエシク	Bell crank guide pin	1
F241		M91210002	ヒラネジ	Screw 3/16(28)X10	2
F242		M91681015	ヒラネジ タンツキ	Hinged screw 1/4(40)X12	1
F243		MG10B0910	レンセツカン	Feed lifting rock shaft link	1
F244		MG10B0763	ベルクランク	Bell crank	1
F245		M91801035	ツマミネジ	Feed regulating screw 9/32(28)X31	1
F246		M91802045	ナット	Nut 9/32(28)	1
F247		MG33A1261	オサエチヨウセツガイ	Presser regulating bracket	1
F248		MG33A1572	ツルマキハネ	Spring	1
F249		MG33A0154	アンナイガネクミタテ	Spring guide bar complete	1
F250		MG33A2361	ハネカケガネ	Spring holder	1
F251		M90922002	ヒラネジ	Screw 9/64(40)X8	3
F252		M93009050	サガネ	Washer	2
F253		M91112002	ヒラネジ	Screw 11/64(40)X12	2
F254		MG30A0296	ソトオサエアンナイ	Walking foot guide bracket	1
F255		MG10B0294	ソトオサエ	Walking foot	1
F256		MG33A0295	オクリアシサエ	Walking foot guide link	1
F911		MG33E0460	ウテクミタテ	Feed lifting rock shaft complete	1

H 糸切り機構
KNIFE ACTUATING MECHANISM

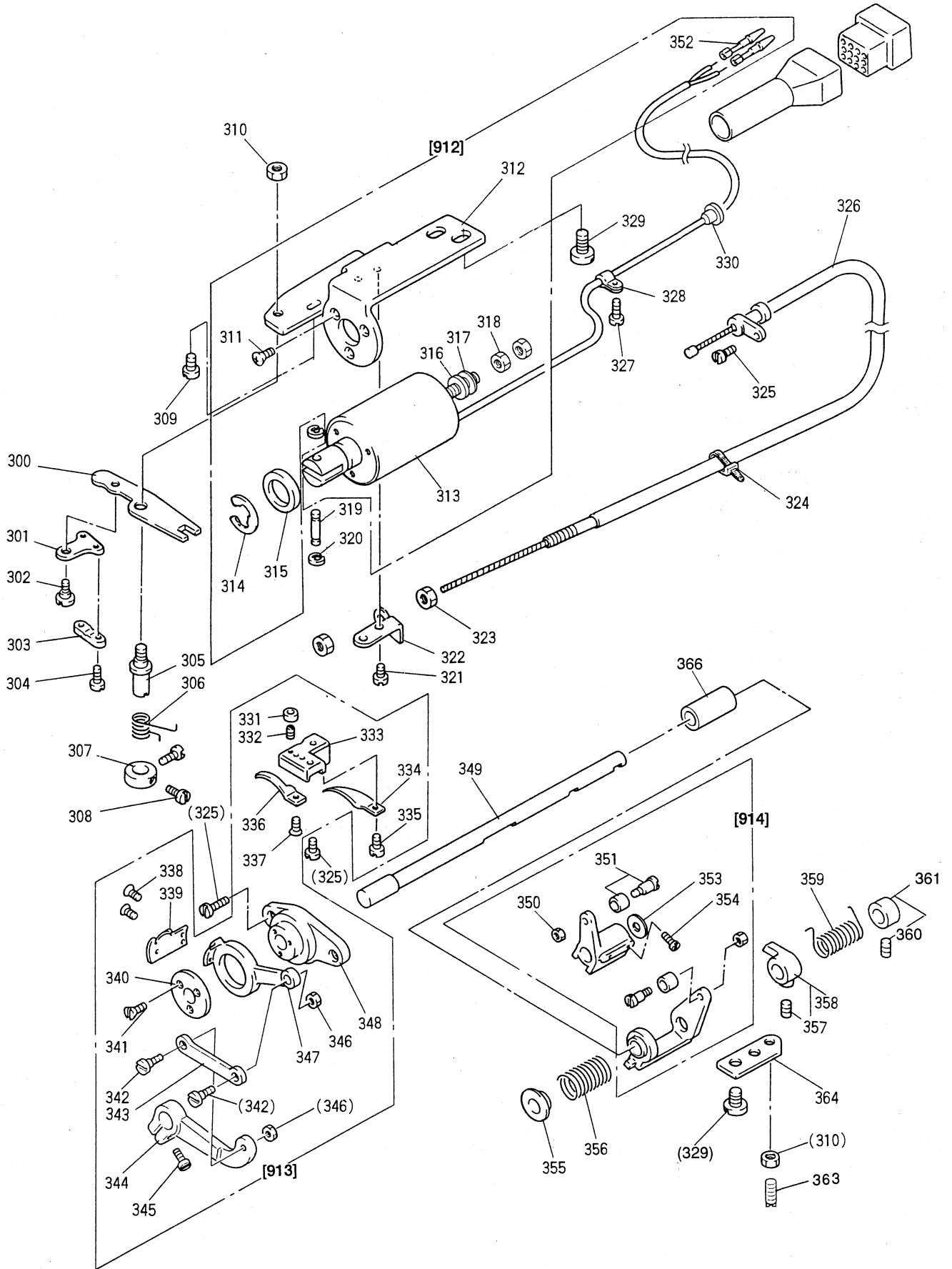

H 系切り機構

KNIFE ACTUATING MECHANISM

Fig.	変更	部品コード	部品名	Description	使用数
No.	Mod	Parts.No.			Amt. Reg.
					BIT
H300		MF00A1391	クドウイタ	Thread trimmer driving lever	1
H301		MF06A1361	カガネ	Flexible wire holder	1
H302		M71144015	ヒラネジダツキ	Stud screw 11/64(40)x5	1
H303		MF36A0750	ブツシュ	Flexible wire presser	1
H304		M90802002	ヒラネジ	Screw 1/8(44)x7	2
H305		M97082030	トクシュネジ	Stud screw 15/64(28)x7.5	1
H306		MF00A1729	ヒネリバネ	Trimming lever spring	1
H307		MF00A1352	カー	Spring support collar	1
H308		M90903002	ヒラネジ	Screw 9/64(40)x6.5	2
H309		M91118002	ヒラネジ	Screw 11/64(40)x10	1
H310		M91502045	ナット	Nut 15/64(28)	2
H311		M94008037	Pサネジ M4x6	Screw M4x6	3
H312		MF00A1509	ソレノイドトリツケイタ	Solenoid bracket	1
H313		—	ソレノイド	Solenoid	1
H314		M90703065	Eカトメワ 12	E-type stop ring 12	1
H315		MF01A0397	クッション	Cushion	1
H316		MF06A0397	クッション	Cushion	1
H317		M70516050	サガネ	Washer	1
H318		M92074075	ナット M5	Nut M5	2
H319		M70428060	ピン	Link stud	1
H320		M70534065	Eカトメワ 4	E-type stop ring 4	2
H321		M91106004	フライネジ	Screw 11/64(40)x8	2
H322		MF06A0780	ホルダ	Holder	1
H323		M91373045	ナット M5	Nut M5x4T	2
H324		MF06A1620	コテイヨウバンド SKB-1M	Band SKB-1M	1
H325		M91106004	フライネジ	Screw 11/64(40)x8	4
H326		MG46E0746	フレキシブルワイヤクミタテ	Flexible wire assy.	1
H327		M91109004	サガネツキフライネジ	Screw 11/64(40)x8	1
H328		M94003099	ナイロンクリップ AB-3N	Cord holder	1
H329		M91510002	ヒラネジ	Screw 15/64(28)x12	4
H330		M91004080	ゴムフツシュ	Rubber plug φ10	1
H331		M91110045	ナット	Nut 9/64(40)	1
H332		M90913001	トメネジ	Set screw 9/64(40)x8.5	1
H333		MF00A1603	トリツケイタ	Bracket for fixed blade	1
H334		MF00A0180	イトアンナイ	Thread finger	1
H335		M90921002	ヒラネジ	Screw 9/64(40)x8	1
H336		MG52A0838	コテイメス	Fixed blade	1
H337		M91102010	サネジ	Screw 9/64(40)x4.1	1
H338		M91151010	サネジ	Screw 11/64(40)x7	2
H339		MG52A0834	メスヒタリ	Movable knife (left)	1
H340		M94006052	サガネ	Thrust collar φ28	1
H341		M90803010	サネジ	Screw 1/8(44)x6	3
H342		M91111015	ヒラネジダツキ	Stud screw 11/64(40)x6.2	2
H343		MF00A8910	リンク	Link	1
H344		MF00A1392	クドウウテ	Knife driving crank	1
H345		M91117002	マルヒラネジ	Screw 11/64(40)x13	1
H346		M91107045	ナット	Nut 11/64(40)	2
H347		MF02A0836	メスダヒタリ	Knife base (left)	1
H348		MF00A1527	タイザ	Knife holding bracket saddle	1
H349		MG46A0454	メスヨウカトウツク	Knife driving shaft	1
H350		M91201045	ナット	Nut 3/16(28)	2
H351		MF01E0411	コロ、コロジクミタテ	Cam follower, Shoulder screw assy.	2
H352		M93003099	ピンターミナル(オス)	Terminal pin(Male)	2
H353		M71018050	サガネ	Rubber washer	1
H354		M91516002	ヒラネジ	Screw 15/64(28)x8.5	2
H355		MF00A0750	ブツシュ	Bushing	1
H356		MF00A9572	ツルマキバネ	Coil spring	1
H357		M91606001	トメネジ	Set screw 1/4(40)x6	1
H358		MF06A0477	ストッパクミタテ	Stopper lever assy.	1
H359		MF00A0729	ヒネリバネ	Coil spring	1
H360		M91602001	トメネジ	Set screw 1/4(40)x4	1
H361		MF01E1352	カークミタテ	Thrust collar assy.	1
H363		M91527001	トメネジ	Set screw 15/64(28)x23	1
H364		MF00A1477	ストッパイタ	Lever stopper plate	1
H365		M90401085	O リング 1AP4	O-ring(1AP4)	1
H366		MG46A0476	スペーサ	Spacer	1
H912		MF06E3519	ソレノイドトリツケイタクミタテ	Thread trimming solenoid	1
H913		MF06E0839	メスダイトリツケイタクミタテ	Knife blaket assy.	1
H914		MG34E0351	カムツイジウウテクミタテ	Cam follower crank assy.	1

J タッチバック機構および検出器機構
TOUCH BACK MECHANISM & DETECTOR MECHANISM

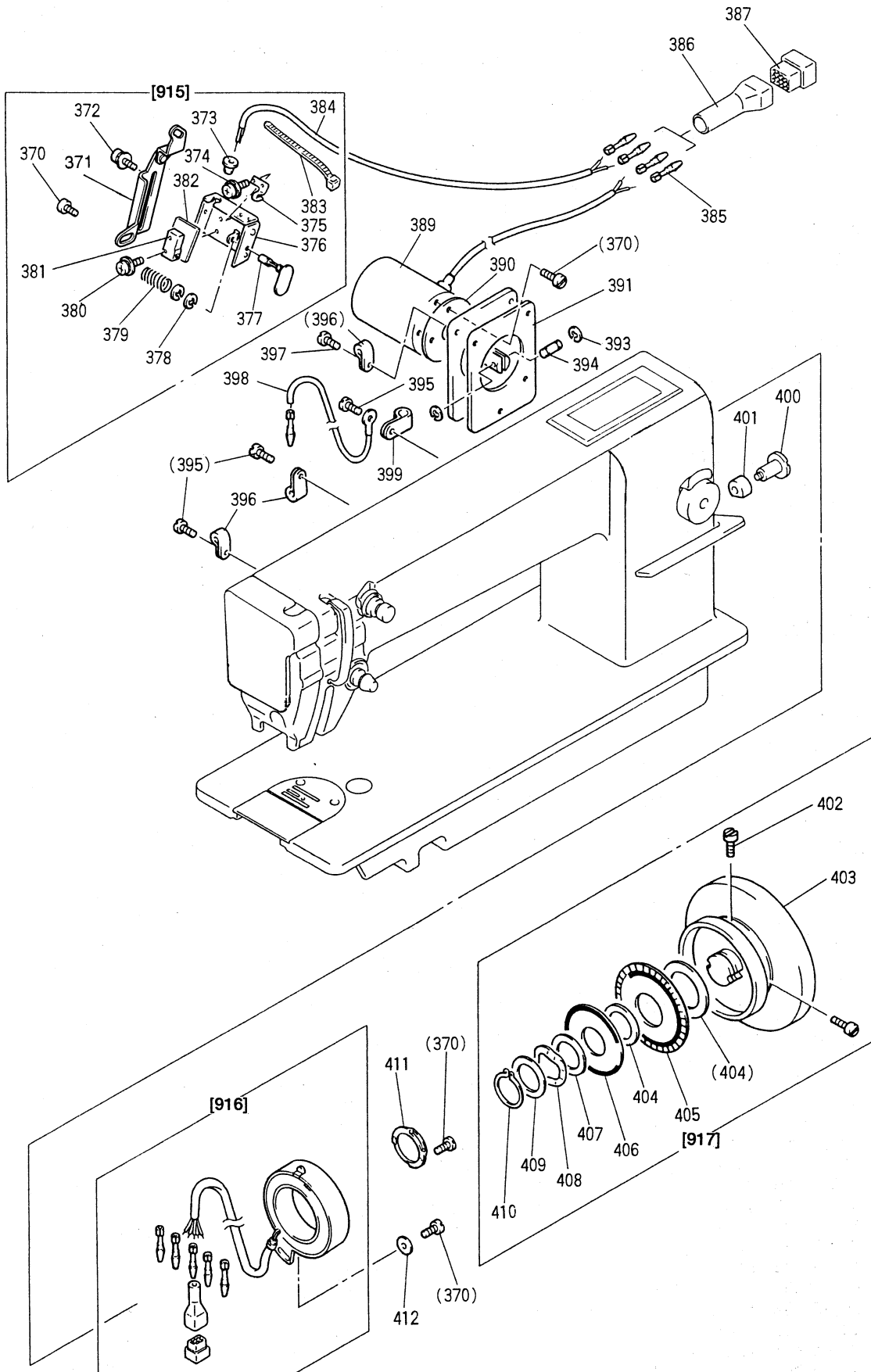

J タッチバック機構および検出器機構

TOUCH BACK MECHANISM & DETECTOR MECHANISM

Fig. No.	変更 Mod	部品コード Parts. No.	部品名	Description	使用数 Amt. Reg.
J370		M91106004	ブ ラマイネジ	Screw 11/64 (40) x8	9
J371		MG46A0601	トリツケイタミタテ	Plate assy.	1
J372		M90308037	SW-PWツキ Pナベネジ	Screw M3X6	2
J373		M91004080	ゴムブツシユ	Rubber plug φ10	1
J374		M90201037	Pナベネジ	Screw 2X4	2
J374		M90315050	ワザガネM2	Washer M2	2
J374		M90306053	ハネザガネM2	Washer M2	2
J375		MF00A0192	イタハネ	Plate spring	1
J376		MG75A1601	スイツチトリツケイタ	Bracket for touch switch	1
J377		MF00A0270	オンボタン	Push button	1
J378		M70533065	Eガ 外メワ 3	E-type stop ring 3	2
J379		MF00A7572	ツルマキハネ	Coil spring	1
J380		M90251037	Pハ インドネジ	Screw M2X8	2
J381		M90208099	マイクロスイッチ	Micro switch	1
J382		MF01A0502	ゼ ツェンイタ	Insulator seat	1
J383		MF06A0620	コトヨウバンド	Band	1
J384		MG46A0508	コードクミタテ	Cord assy.	1
J385		M93303099	ピン 1380TL	Terminal pin	4
J386		MG68A0366	コネクタキャップ	Connector cap	1
J387		M91018099	コネクタ-1360P	Nylon connector 12-pole	1
J389		MG34E0519	ソレノイド	Solenoid	1
J390		MF01A0691	ガ スケット	Gasket	1
J391		MG34A0880	ヨコフタ	Arm side cover	1
J393		M70534065	Eガ 外メワ 4	E-type stop ring 4	2
J394		M70428060	ピン	Link stud	1
J395		M91109004	ザガネツキブ ラマイネジ	Screw 11/64 (40) X8	6
J396		M94003099	ナイロンクリップ AB-3N	Cord holder	3
J397		M91111004	ブ ラマイネジ	Screw 11/64 (40) X10	1
J398		M97003095	アースセンクミタテ	Ground wire assy.	1
J399		MB60A1620	ナイロンクリップ AB-8N	Cord holder	1
J400		M91515015	ヒラネジ タンツキ	Hinged screw	1
J401		MN36A0417	ゴムワ	Rubber cushion	1
J402		M91502002	ヒラネジ	Set screw 15/64 (28) X12	2
J403		MG34A0682	プ リー	Pulley	1
J404		MF01A0476	スペーサ A	Spacer A	2
J405		MF01A2694	ハンシヤパン B12	Speed command disc B12 (down)	1
J406		MF01A1694	ハンシヤパン B21	Speed command disc B21 (up)	1
J407		MF01A1476	スペーサ B	Spacer B	1
J408		MF01A0259	ハンテナイオサエスフ リンク	Supporter spring	1
J409		M93001050	ザガネ	Washer 30	1
J410		M90330065	Cガ 外メワ	Retaining ring-C type 30	1
J411		MF01A0257	オサエイタ	Detector bracket supporter	1
J412		M93002050	ザガネ	Washer 12	1
J915		MG46E0534	タッチスイッチクミタテ	Touch switch assy.	1
J916		MB60A2406	ケンシユツキクミタテ (センサー)	Detector bracket assy. (sensor)	1
J917		MG34E0682	プ リークミタテ	Pulley assy.	1

K 給油機構
OIL LUBRICATION MECHANISM

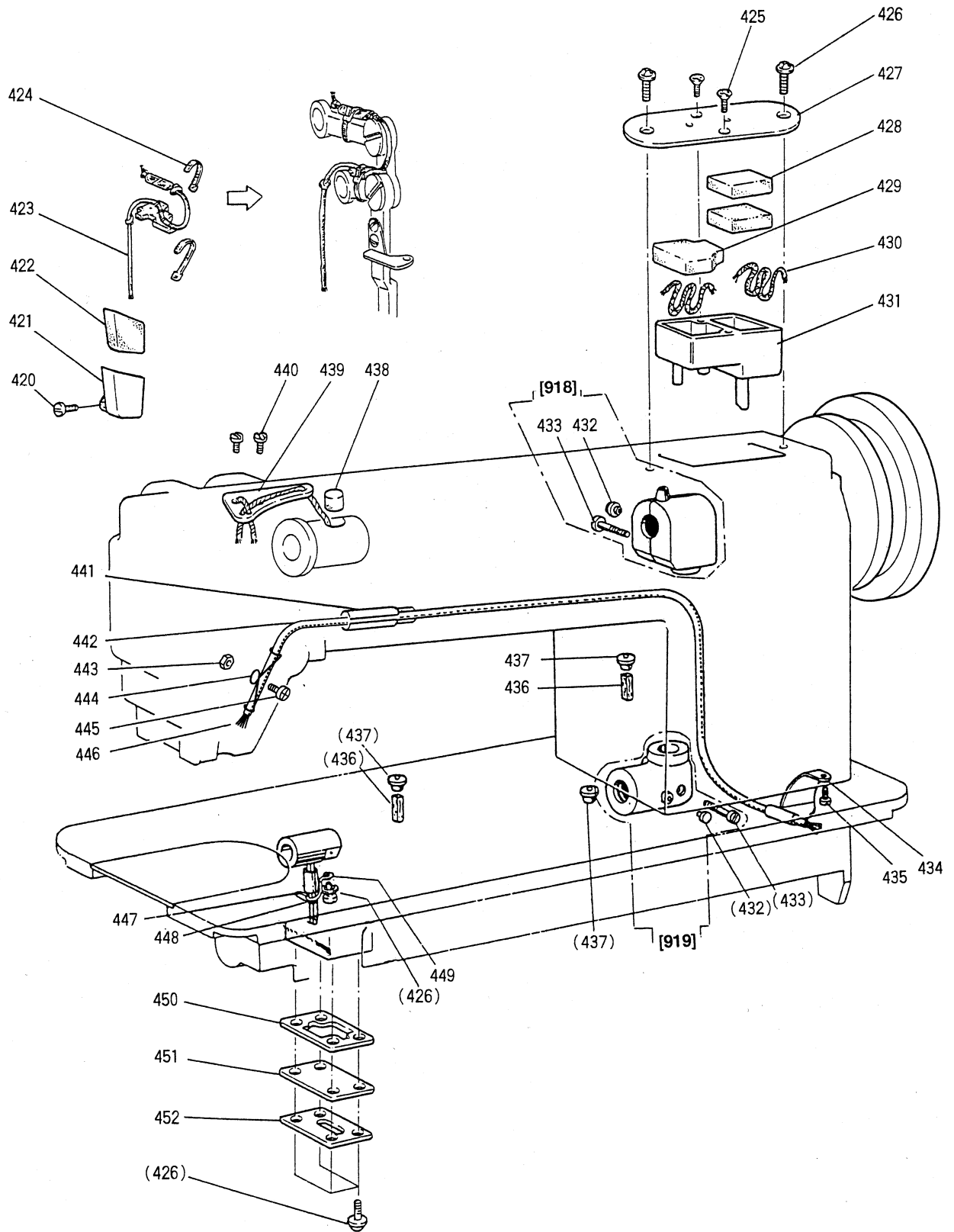

K 給油機構

OIL LUBRICATION MECHANISM

Fig. No.	変更 Mod	部品コード Parts.No.	部品名	Description	使用数 Amt. Reg. BIT
K420		M90908003	マルヒラネジ	Screw 9/64 (40) x6	1
K421		MG33A0138	オイルタンク	Oil reservoir	1
K422		MG33A0740	フェルト	Felt	1
K423		MG33E0688	パイプヒモクミタテ	Oil pipe & wick complete	1
K424		MF06A1620	コテヨウバンド SKB-1M	Band SKB-1M	2
K425		M90357037	Pサラタツピニングネジ V 3X8	Screw 3x8	2
K426		M91109004	サガネツキプライネジ	Screw 11/64 (40) x8	7
K427		MG33A0134	アブラタミキ	Cap for oiler (right)	1
K428		MG33A1740	フェルト	Felt	2
K429		MG33A2740	フェルト	Felt	1
K430		MF10E3148	ヒモ 3DX180	Oil wick	2
K431		MG33A1138	オイルタンクミキ	Oil reservoir (right)	1
K432		M90573080	ゴムセン	Rubber plug φ5.7	2
K433		M90531037	P ナベネジ 5X14	Screw M5x14	2
K434		MG33A0780	ホルダ	Oil pipe holder	1
K435		M91106004	プライネジ	Screw 11/64 (40) x8	1
K436		MG30A0740	フェルト	Felt	2
K437		MN10A4742	フタ	Cap for oiler	3
K438		MF10A2740	フェルト	Felt	1
K439		MG33E0601	トリツケイタヒモクミタテ	Oil braid fitting plate	1
K440		M90939002	ヒラネジ	Screw 9/64 (40) x11	2
K441		MG50A0688	パイプ	Oil pipe	1
K442		MG36A0731	パイプ	Oil pipe	1
K443		M91103045	ナット	Nut 11/64 (40)	1
K444		MG42A1689	パイプホルダ	Pipe holder	1
K445		M91104003	マルヒラネジ	Screw 11/64 (40) x12	1
K446		MG36A0148	ヒモ	Oil wick	3
K447		MG33A0688	パイプ	Oil pipe	1
K448		MG50A2740	フェルト	Felt	1
K449		MG43A0689	センサイクハネ	Pipe holder	1
K450		MG42A2691	ガスケット	Gasket for oil reservoir	1
K451		MG50A0139	フタ	Oil reservoir cover	1
K452		MG50A0257	オサエイタ	Plate	1
K918		MG33E0711	ハグルマハコウイクミタテ	Arm shaft bevel gear box complete	1
K919		MG33E0712	ハグルマハコシタクミタテ	Hook shaft bevel gear box complete	1

L 付属品関係
 ACCESSORIES

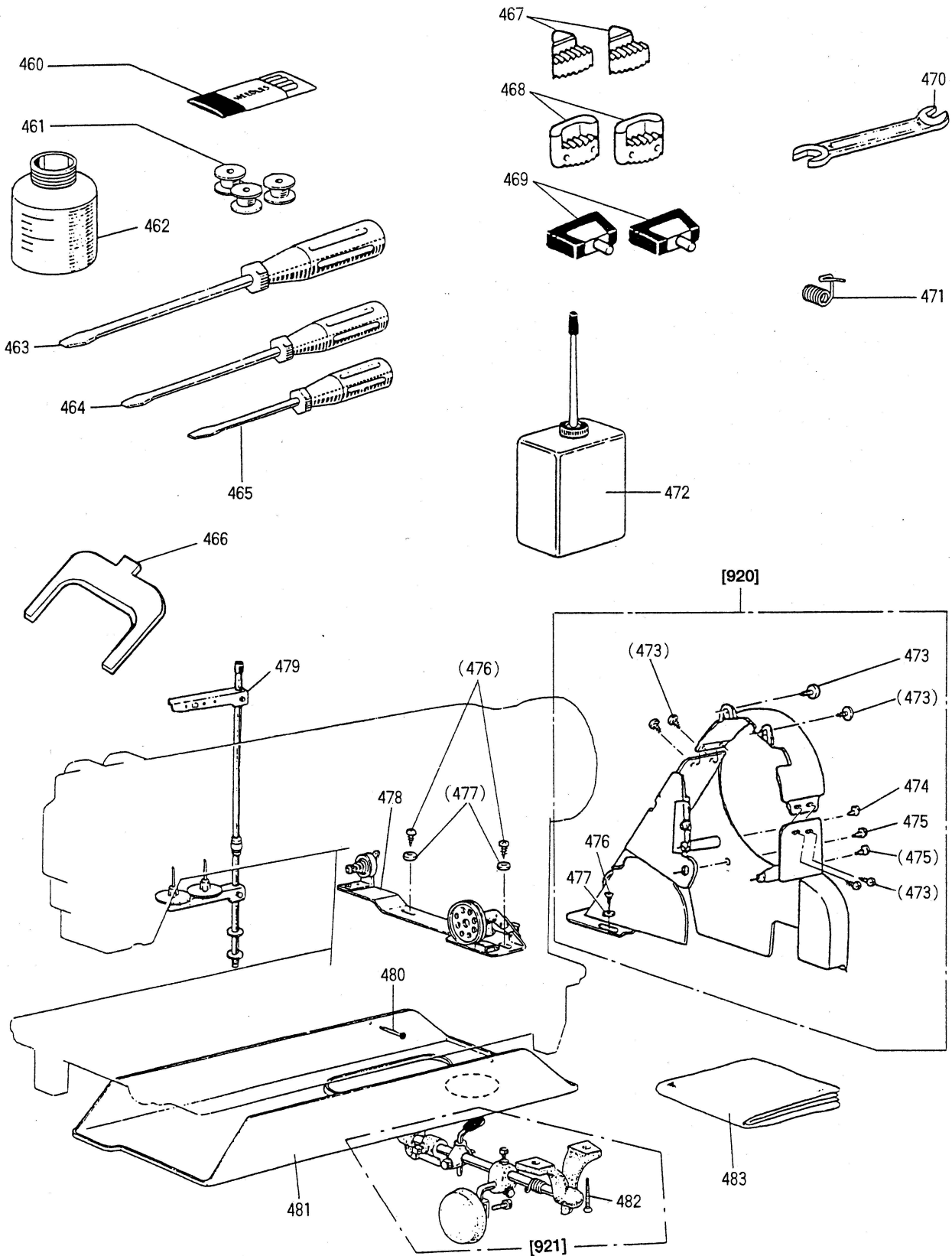

L 付属品関係

ACCESSORIES

Fig. No.	変更 Mod	部品コード Parts.No.	部品名	Description	使用数 Amt. Reg.
L460		MG33E0128	ハリセット	Needle set (DPX17#22)	1
L461		MF25B0123	ホビン	Bobbin	3
L462		MG33A0130	アブラビン	Oil pot	1
L463		MG33A0608	ドライバー(大)	Screw driver (large)	1
L464		MF06A0608	ドライバー(中)	Screw driver (middle)	1
L465		MF06A1608	ドライバー(小)	Screw driver (small)	1
L466		MF01A0565	スピードコマンド調整板	Speed command disc adjusting plate	1
L467		MG51A1419	ボウシゴム	Vibration preventing rubber	2
L468		MG51A0419	ボウシゴム	Vibration preventing rubber	2
L469		MF01E0418	テーブルヒンジ	Table hinge with rubber cushion	2
L470		MG33A0479	スパナ	Spanner	1
L471		MF02A0187	イトリバネ	Thread take-up spring	1
L472		MG33A0137	アブラサシ 18	Oil with oiler	1
L473		M91109004	ザガネツキフライネジ	Screw 11/64 (40)x8	6
L474		M91072004	SW-PWツキPナネジ	Screw SW-PW M4X0.7X14	1
L475		M91508004	フライネジ	Screw 15/64 (28)x8	2
L476		M90401041	マルモクネジ	Screw 4.5x20	4
L477		M70517050	ミガキサガネ	Washer 5	4
L478		MF08E0190	イトマキシカケ	Bobbin winder assy.	1
L479		MF33E0193	イトタテアイセット	Thread stand assy.	1
L480		MQ80A0375	クギ N25	Nail N25	10
L481		MG36E0131	アブラウケミタテ	Oil reservoir assy.	1
L482		M90412040	サラモクネジ 4.5X25	Screw 4.5x25	4
L483		MG33A0734	ビニールカバー	Vinyl cover	1
L920		MG33E0776	ベルトカバーセット	Belt cover assy.	1
L921		MG36E0727	ヒザアゲシカケセット	Knee lifter assy.	1

M 索引
INDEX

部品コード	ページ	Fig	部品コード	ページ	Fig	部品コード	ページ	Fig
Parts. No.	Page	No.	Parts. No.	Page	No.	Parts. No.	Page	No.
M70428060	P17	H319	M91004080	P17	H330	M91506001	P5	B75
M70428060	P19	J394	M91004080	P19	J373	M91506001	P11	E200
M70516050	P17	H317	M91018099	P19	J387	M91506001	P15	G264
M70517050	P23	L477	M91072004	P23	L474	M91508001	P3	A16
M70533065	P19	J378	M91101046	P3	A09	M91508004	P23	L475
M70534065	P9	D157	M91102010	P17	H337	M91510002	P17	H329
M70534065	P17	H320	M91102011	P3	A37	M91513001	P5	B58
M70534065	P19	J393	M91103045	P21	K443	M91513001	P7	C116
M70535065	P7	C104	M91104003	P15	G288	M91515002	P9	D174
M71018050	P17	H353	M91104003	P21	K445	M91515015	P19	J400
M71144015	P17	H302	M91106003	P3	A39	M91516002	P7	C113
M71216002	P9	D187	M91106004	P3	A07	M91516002	P9	D154
M90201037	P19	J374	M91106004	P5	B59	M91516002	P17	H354
M90204060	P3	A22	M91106004	P7	C102	M91527001	P17	H363
M90207061	P13	F221	M91106004	P9	D165	M91551015	P13	F229
M90208099	P19	J381	M91106004	P13	F237	M91572045	P13	F227
M90251037	P19	J380	M91106004	P15	G275	M91601036	P11	E198
M90301064	P13	F236	M91106004	P17	H321	M91602001	P5	B70
M90304053	P11	E194	M91106004	P17	H325	M91602001	P7	C114
M90306053	P19	J374	M91106004	P19	J370	M91602001	P17	H360
M90308037	P19	J372	M91106004	P21	K435	M91602020	P7	C127
M90315050	P19	J374	M91107002	P3	A17	M91603003	P7	C111
M90315065	P7	C118	M91107045	P17	H346	M91603003	P11	E210
M90320065	P5	B72	M91108001	P3	A04	M91603003	P13	F226
M90325065	P13	F232	M91108001	P11	E205	M91604045	P11	E203
M90330065	P19	J410	M91108001	P13	F223	M91605045	P3	A28
M90357037	P21	K425	M91109002	P15	G265	M91606001	P5	B62
M90401041	P23	L476	M91109004	P3	A02	M91606001	P13	F234
M90401061	P11	E190	M91109004	P17	H327	M91606001	P17	H357
M90401085	P17	H365	M91109004	P19	J395	M91610001	P5	B81
M90402064	P15	G273	M91109004	P21	K426	M91615015	P11	E196
M90412040	P23	L482	M91109004	P23	L473	M91620045	P11	E192
M90421060	P15	G279	M91110001	P7	C121	M91681015	P13	F242
M90507063	P13	F240	M91110001	P15	G271	M91801035	P13	F245
M90531037	P21	K433	M91110002	P9	D162	M91802006	P5	B64
M90534060	P9	D158	M91110045	P17	H331	M91802045	P11	E214
M90573080	P21	K432	M91111004	P19	J397	M91802045	P13	F246
M90601050	P11	E202	M91111015	P17	H342	M91803015	P11	E213
M90601050	P13	F228	M91112002	P7	C137	M92001016	P15	G280
M90604002	P3	A33	M91112002	P13	F253	M92074075	P17	H318
M90625053	P3	A30	M91116002	P3	A06	M93001050	P19	J409
M90703065	P17	H314	M91117002	P17	H345	M93002050	P19	J412
M90704063	P15	G274	M91118002	P7	C134	M93003099	P17	H352
M90720063	P9	D151	M91118002	P17	H309	M93009050	P13	F252
M90801006	P7	C130	M91151010	P17	H338	M93202047	P15	G261
M90802002	P17	H304	M91182080	P3	A38	M93223035	P15	G260
M90803010	P17	H341	M91201045	P17	H350	M93303099	P19	J385
M90806002	P7	C105	M91203002	P7	C101	M94003099	P17	H328
M90815002	P5	B56	M91204003	P7	C139	M94003099	P19	J396
M90901002	P3	A29	M91207003	P9	D175	M94006052	P17	H340
M90901080	P3	A41	M91210002	P13	F241	M94008037	P17	H311
M90903002	P17	H308	M91223015	P15	G278	M95003053	P9	D172
M90904060	P7	C110	M91251045	P15	G284	M97003095	P19	J398
M90908003	P21	K420	M91305080	P3	A03	M97082030	P17	H305
M90909003	P3	A14	M91373045	P17	H323	MB60A1620	P19	J399
M90910003	P11	E195	M91501007	P9	D168	MB60A2406	P19	J916
M90913001	P17	H332	M91502002	P9	D159	MF00A0180	P17	H334
M90921002	P17	H335	M91502002	P19	J402	MF00A0181	P3	A13
M90922002	P13	F251	M91502045	P17	H310	MF00A0192	P19	J375
M90922002	P15	G270	M91502050	P7	C117	MF00A0257	P9	D185
M90939002	P21	K440	M91503001	P7	C123	MF00A0270	P19	J377
M91000085	P9	D178	M91505016	P15	G282	MF00A0350	P7	C126

M 索引
INDEX

部品コード	ページ	Fig	部品コード	ページ	Fig	部品コード	ページ	Fig
Parts. No.	Page	No.	Parts. No.	Page	No.	Parts. No.	Page	No.
MF00A0453	P7	C125	MF10A2740	P21	K438	MG30E1594	P15	G286
MF00A0729	P17	H359	MF10E3148	P21	K430	MG33A0130	P23	L462
MF00A0750	P17	H355	MF20A0229	P7	C133	MG33A0134	P21	K427
MF00A1352	P17	H307	MF20A0664	P5	B54	MG33A0137	P23	L472
MF00A1391	P17	H300	MF25B0123	P7	C135	MG33A0138	P21	K421
MF00A1392	P17	H344	MF25B0123	P23	L461	MG33A0154	P13	F249
MF00A1477	P17	H364	MF25E1125	P7	C908	MG33A0221	P15	G277
MF00A1509	P17	H312	MF26B0101	P3	A36	MG33A0233	P5	B80
MF00A1527	P17	H348	MF30A0325	P5	B60	MG33A0281	P7	C107
MF00A1603	P17	H333	MF30A0352	P7	C122	MG33A0283	P7	C103
MF00A1729	P17	H306	MF30A0632	P9	D173	MG33A0285	P7	C108
MF00A1910	P9	D156	MF30E0280	P5	B74	MG33A0295	P13	F256
MF00A7572	P19	J379	MF33E0193	P23	L479	MG33A0384	P5	B73
MF00A8910	P17	H343	MF36A0245	P3	A10	MG33A0426	P3	A31
MF00A9572	P17	H356	MF36A0750	P17	H303	MG33A0462	P13	F220
MF00E0550	P3	A901	MF36A1180	P3	A05	MG33A0479	P23	L470
MF01A0257	P19	J411	MF40A0331	P5	B82	MG33A0530	P9	D155
MF01A0259	P19	J408	MF40A0332	P5	B91	MG33A0571	P15	G283
MF01A0397	P17	H315	MF40A0333	P5	B83	MG33A0602	P11	E193
MF01A0476	P19	J404	MF40A2708	P9	D161	MG33A0608	P23	L463
MF01A0502	P19	J382	MF60A0232	P5	B66	MG33A0688	P21	K447
MF01A0565	P23	L466	MF60A0252	P15	G272	MG33A0729	P15	G287
MF01A0691	P19	J390	MF60A0262	P15	G267	MG33A0734	P23	L483
MF01A1476	P19	J407	MF60A0633	P9	D171	MG33A0740	P21	K422
MF01A1694	P19	J406	MF60A0634	P9	D169	MG33A0744	P9	D150
MF01A2694	P19	J405	MF60A0663	P5	B52	MG33A0761	P9	D152
MF01E0331	P5	B905	MF60A0700	P5	B78	MG33A0765	P13	F238
MF01E0332	P5	B906	MF60A0700	P13	F230	MG33A0780	P21	K434
MF01E0411	P17	H351	MF60A0740	P5	B86	MG33A0833	P13	F224
MF01E0418	P23	L469	MF60A0740	P7	C119	MG33A0873	P3	A01
MF01E1352	P17	H361	MF60A0742	P5	B50	MG33A0910	P9	D153
MF02A0187	P3	A21	MF60A1383	P5	B63	MG33A0950	P11	E201
MF02A0187	P23	L471	MF60A1740	P5	B77	MG33A0956	P13	F235
MF02A0245	P9	D180	MF60A2740	P5	B79	MG33A1138	P21	K431
MF02A0553	P3	A23	MF67B0522	P5	B89	MG33A1261	P13	F247
MF02A0836	P17	H347	MF70A0277	P7	C140	MG33A1285	P11	E207
MF03A0584	P3	A08	MF70E0276	P7	C136	MG33A1572	P13	F248
MF05A0572	P9	D176	MF80A0352	P5	B69	MG33A1740	P21	K428
MF06A0397	P17	H316	MF80A0352	P7	C115	MG33A2361	P13	F250
MF06A0477	P17	H358	MF85A0640	P9	D179	MG33A2740	P21	K429
MF06A0608	P23	L464	MF90A0553	P3	A12	MG33E0128	P23	L460
MF06A0620	P19	J383	MG10B0294	P13	F255	MG33E0460	P13	F911
MF06A0780	P17	H322	MG10B0411	P13	F239	MG33E0601	P21	K439
MF06A0852	P9	D177	MG10B0763	P13	F244	MG33E0688	P21	K423
MF06A0950	P9	D181	MG10B0910	P13	F243	MG33E0711	P21	K918
MF06A1361	P17	H301	MG30A0154	P15	G276	MG33E0712	P21	K919
MF06A1608	P23	L465	MG30A0278	P7	C100	MG33E0760	P5	B907
MF06A1620	P17	H324	MG30A0296	P13	F254	MG33E0776	P23	L920
MF06A1620	P21	K424	MG30A0460	P13	F222	MG34A0291	P9	D160
MF06A1631	P9	D183	MG30A0463	P13	F225	MG34A0325	P5	B76
MF06E0839	P17	H913	MG30A0530	P11	E199	MG34A0530	P9	D170
MF06E3519	P17	H912	MG30A0601	P3	A18	MG34A0682	P19	J403
MF08E0190	P23	L478	MG30A0700	P7	C129	MG34A0708	P9	D166
MF10A0104	P7	C106	MG30A0740	P21	K436	MG34A0880	P19	J391
MF10A0267	P15	G268	MG30A0760	P13	F233	MG34E0210	P3	A902
MF10A0332	P5	B90	MG30A0910	P11	E197	MG34E0351	P17	H914
MF10A0471	P3	A34	MG30B0464	P11	E204	MG34E0519	P19	J389
MF10A0555	P3	A24	MG30B0593	P15	G285	MG34E0640	P9	D909
MF10A0572	P9	D167	MG30B0740	P13	F231	MG34E0682	P19	J917
MF10A0709	P3	A20	MG30B0954	P11	E212	MG35A1830	P3	A40
MF10A1555	P3	A11	MG30E0410	P11	E208	MG35E0306	P7	C112
MF10A2740	P5	B51	MG30E0465	P11	E211	MG36A0148	P21	K446

M 索引
INDEX

部品コード	ページ	Fig	部品コード	ページ	Fig	部品コード	ページ	Fig
Parts. No.	Page	No.	Parts. No.	Page	No.	Parts. No.	Page	No.
MG36A0230	P5	B71						
MG36A0265	P15	G263						
MG36A0284	P7	C109						
MG36A0450	P7	C124						
MG36A0467	P11	E209						
MG36A0725	P15	G281						
MG36A0731	P21	K442						
MG36A1284	P7	C138						
MG36E0131	P23	L481						
MG36E0467	P11	E910						
MG36E0727	P23	L921						
MG37A0128	P5	B57						
MG37B0452	P7	C120						
MG40E0580	P5	B904						
MG41B0256	P15	G269						
MG42A0181	P5	B55						
MG42A1689	P21	K444						
MG42A2691	P21	K450						
MG43A0181	P3	A15						
MG43A0689	P21	K449						
MG43A1181	P3	A32						
MG44E0662	P5	B61						
MG46A0454	P17	H349						
MG46A0476	P17	H366						
MG46A0508	P19	J384						
MG46A0601	P19	J371						
MG46E0534	P19	J915						
MG46E0746	P17	H326						
MG50A0139	P21	K451						
MG50A0257	P21	K452						
MG50A0451	P7	C128						
MG50A0520	P5	B87						
MG50A0572	P9	D163						
MG50A0660	P5	B53						
MG50A0688	P21	K441						
MG50A0740	P5	B68						
MG50A1740	P11	E206						
MG50A2740	P21	K448						
MG51A0419	P23	L468						
MG51A1419	P23	L467						
MG52A0245	P3	A26						
MG52A0834	P17	H339						
MG52A0838	P17	H336						
MG52E0256	P15	G269						
MG68A0366	P19	J386						
MG75A0120	P7	C132						
MG75A0841	P9	D184						
MG75A1601	P19	J376						
MG75E0470	P3	A903						
MM11A0556	P3	A25						
MN10A4742	P21	K437						
MN15A0708	P9	D164						
MN30A0216	P15	G266						
MN36A0417	P19	J401						
MQ50A0148	P5	B85						
MQ50A0181	P3	A19						
MQ70A0521	P5	B84						
MQ80A0375	P23	L480						
MT60A0802	P3	A27						
MV01A0259	P15	G262						
MV88A0740	P5	B67						
MV88A0740	P11	E191						

三菱電機株式会社

お問い合わせは下記へどうぞ

FAシステム事業本部 機器計画部 駆動機器グループ 〒100-8310 東京都千代田区丸の内 2-7-3 (東京ビル)

代表電話番号 (03)3218-6631 代表FAX番号 (03)3218-6823

MITSUBISHI ELECTRIC CORPORATION

FACTORY AUTOMATION SYSTEM GROUP

Tokyo 100-8310, Japan

Fax : +81-3-3218-6821