



DOUBLE-NEEDLE LOCKSTITCH NEEDLE-FEED
CORNER STITCHING AUTOMATIC UNDERTRIMMER
INDUSTRIAL SEWING MACHINE

MODEL

LT2-2250-B1T

INSTRUCTION MANUAL

INTRODUCTION

Thank you very much for purchasing Mitsubishi industrial sewing machine.

Please read this instruction manual before operating the sewing machine. Please read also “Safety Manual”, “Instruction manual for Mitsubishi Limiservo X” and operate the sewing machine correctly and safely.

PRECAUTION BEFORE STARTING OPERATION

1 Safety Precautions

1. When turning the power on, keep your hands and fingers away from the area around/under the needle and the area around the pulley.
2. The power must be turned off when the machine is not used, or when the operator leaves his/her seat.
3. The power must be turned off before tilting the machine head, installing or removing the “V” belt, adjusting the machine, or replacing parts.
4. Avoid placing fingers, hairs, obstacles, etc. near the pulley, “V” belt, bobbin winder wheel, or motor when the machine is in operation. Injury could result.
5. Don't put fingers into the thread take-up lever cover, around/under the needle, or pulley when the machine is in operation.
6. If the belt cover, the finger guard, and/or the eye guard are installed, don't operate the machine without these safety devices.

2 Precaution before Starting Operation

1. If the machine's oil pan has an oil sump, never operate the machine without filling oil in it.
2. If the machine is lubricated by a drop oiler, never operate the machine without lubricating.
3. When a new sewing machine is operated, verify the rotational direction of the pulley with the power on.
(The pulley should rotate counterclockwise when viewed from the pulley.)
4. Verify voltage and (single or three) phase indicated on the nameplate of the motor.

3 Precaution for Operating Conditions

1. Avoid using the machine at abnormally high temperature (35°C or higher) or low temperature (5°C or lower). Otherwise, machine failure may result.
2. Avoid using the machine in dusty conditions.
3. Avoid using the machine in conditions filled with a lot of electric noises such as high-frequency welders.

CONTENTS

PREPARATION FOR OPERATION	1
1 Adjustment of the needle stopping position	1
USAGE PRECAUTION	2
1 Lubrication (1)	2
2 Lubrication (2)	2
3 Lubrication condition and adjustment on lubrication to the thread take up lever	3
4 Adjustment of lubrication to the rotating hook	3
5 Precaution for the built-in type detector	3
6 Installation of the belt cover	3
7 Precaution on operation	3
HOW TO USE	4
1 Installation of needles	4
2 Winding of the bobbin thread	4
3 Selection of the thread	5
4 Threading of needle threads	5
5 Adjustment of feed (stitch) length and backstitch	7
6 Adjustment of the needle thread guide	7
7 Setting of bobbins	7
8 Threading of bobbin threads	8
9 Adjustment of bobbin threads tension	8
10 Adjustment of needle threads tension	8
11 Adjustment of the thread take up spring	8
12 Timing between the rotating hook motion and the needle motion	9
13 Adjustment of the presser foot pressure	10
14 Adjustment of the feed dog height	11
15 Relationship between the rotating hook motion and the thread take-up lever motion	12
16 Relationship between the rotating hook motion and the opener motion	12
17 Relationship between the needle motion and the feed dog motion	13
18 Operation of the needle bar (left or right)	14
19 Relationship between angle of the corner stitching and stitch length	14
20 Adjustment of the corner stitching device "0" position	15
21 Adjustment of the corner stitching device / height of the needle bar	15
22 Installation position of the feed cam	16
23 Adjustment of forward/backward feed length	16
24 Installation of the movable knife	17
25 Installation position of the thread trimmer cam	18
26 Adjustment of the thread trimmer cam	18
27 Adjustment of the holding pressure of the bobbin thread	19
28 Adjustment of the thread tension releasing	20
29 Adjustment of meshing pressure between the movable knife and the fixed knife	21
30 Sharpening of the fixed knife	21
31 Adjustment of the thread trimmer with changing the width between needles	22
32 Installation of the solenoid arm	23
33 Removal procedure of the hook	23
SPECIFICATIONS	24

PREPARATION FOR OPERATION

1 Adjustment of the needle stopping position

1. Adjustment of "UP" position

When the pedal is kicked down by heel, the machine stops at "UP" position.

If marks deviate larger than 3 mm, adjust as follows.

- (1) Disconnect the plug (12pins) of cable from the machine head.
- (2) Run the machine and stop at "UP" position.
- (3) While holding the pulley, insert the "Adjusting tool" in the hole (A), then turn the tool.

2. Adjustment of "Down" position

When the pedal is "Neutral" the machine stops at "Down" position.

If marks deviate large than 5 mm, adjust as follows.

- (1) Disconnect the plug (12pins) of cable from the machine head.
- (2) Run the machine and stop at "Down" position.
- (3) While holding the pulley, insert the "Adjusting tool" in the hole (B), then turn the tool.

3. Confirm the stop operation, then set the plug (12pins) coming from the machine head into the receptacle.

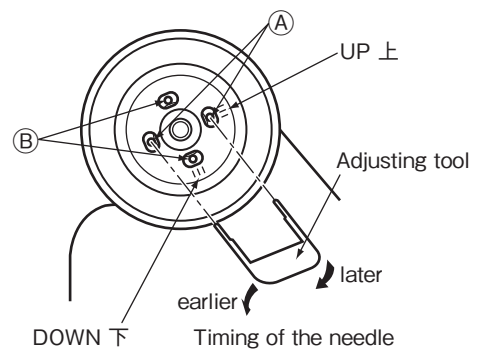
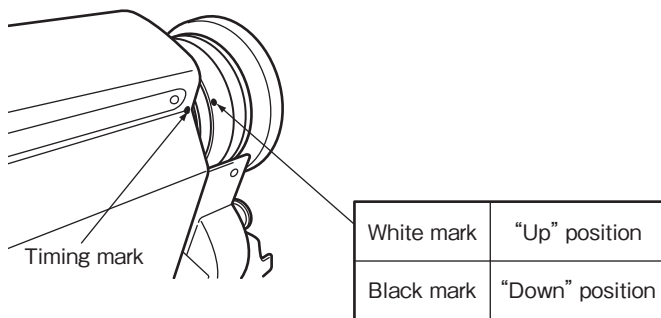

USAGE PRECAUTION

1 Lubrication (1)

Fill the oil reservoir with oil up to “H” mark.
Oil level should be periodically checked. If oil level is found below “L” level replenish oil to “H” level.
For oil, use “MC70M” specified by Mitsubishi.

※ Refer

MC70M : Specific gravity (15°C) = 0.86 (g/cm³)
: Viscosity (40°C) = 10.9 (mm²/s)

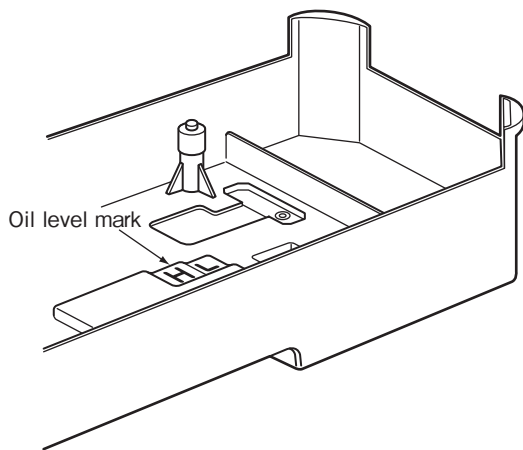

2 Lubrication (2)

When a new sewing machine is used for the first time, or sewing machine left out of use for considerably long time is used again, replenish a suitable amount of oil to the portions indicated by arrows in the below figure.

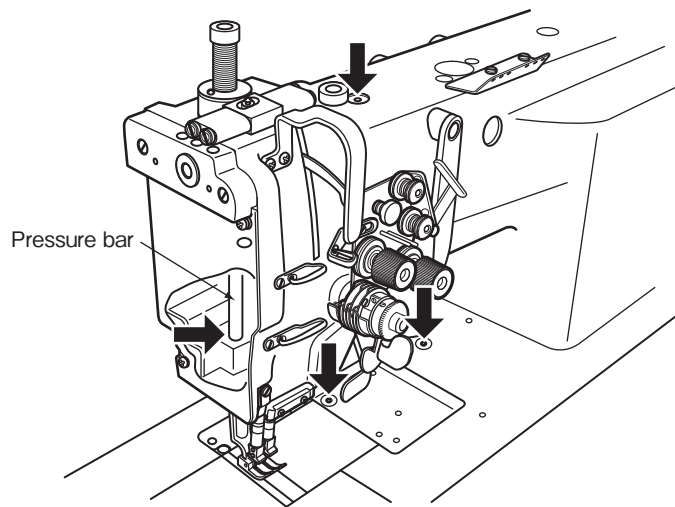

USAGE PRECAUTION

3 Lubrication condition and adjustment on lubrication to the thread take up lever

- (1) See dripping of oil through the oil sight window to check oiling condition during operation.
- (2) Adjust lubrication quantity to the thread take up lever mechanism by turning the lubrication adjustment screw.

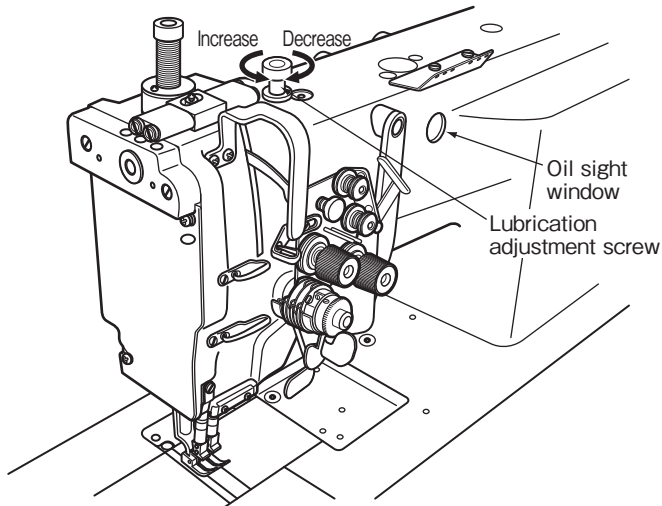

4 Adjustment of lubrication to the rotating hook

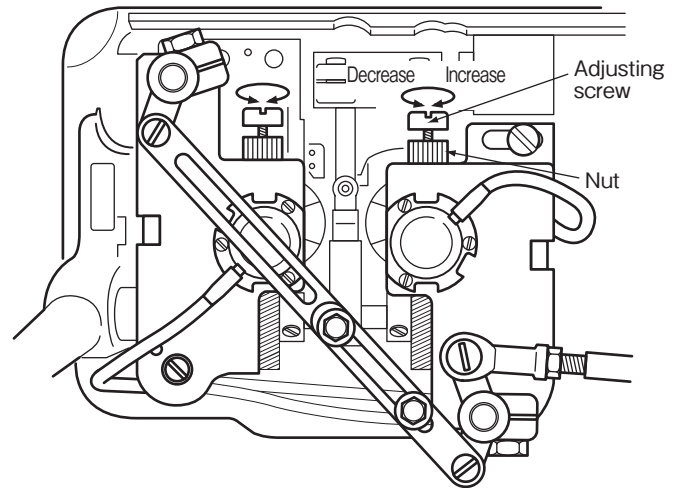

5 Precaution for the built-in type detector

1. Since the optical type detecting element is used in the detector, prevent dust or oil from sticking to the detecting plate when the sewing machine pulley is removed for adjustment. If they have stuck, wipe them off with soft cloth carefully so that the surface is not scratched, do not let oil permeate the clearance on the detecting plate.
2. In case of disconnection of the position detector connector, running off the belt or complete constraint and over load, the motor is automatically turned off after predetermined time to prevent burning of the motor. (However, in case of half-constraint and over load, the power may not be turned off.) After the failure is eliminated, the normal operation is resumed by turning off the power once then turning on again. The same operation occurs for the detector malfunction or the line breakage.

6 Installation of the belt cover

1. Install the belt cover on the machine side for safety. Refer to the provided instruction document contained in the same package.
2. Install the belt cover on the motor side for safety.

7 Precaution on operation

- (1) When the power is turned on or off, keep foot away from the pedal.
- (2) It should be noted that the brake may not work when the power is interrupted or power failure occurs during sewing machine operation.
- (3) Since dust in the control box might cause malfunction or control troubles, be sure to keep the control box cover close during operation.
- (4) Do not apply a multimeter to the control circuit for checking, otherwise voltage of multimeter might damage semiconductor components in the circuit.

HOW TO USE

1 Installation of needles

Note: Before installing the needles, be sure to turn off the power.

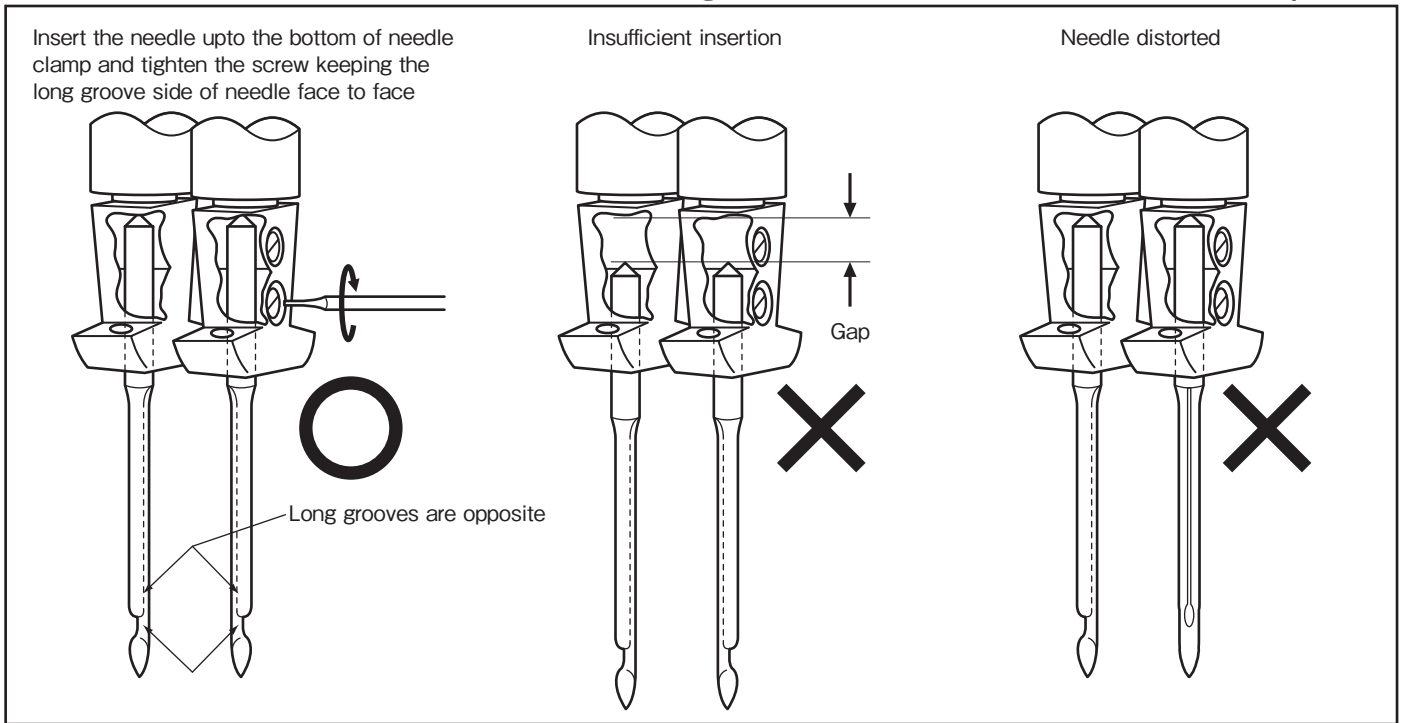

2 Winding of the bobbin thread

Note: When bobbin thread is wound, keep the presser foot lifted.

- Adjustment ● Tension of wound thread Slack winding is recommended for polyester thread and nylon thread.
- Conically wound thread Move the thread guide toward smaller diameter of wound thread layer.
- Amount of wound thread Loosen the winding amount adjustment screw to decrease thread winding amount and tighten the screw to increase thread winding amount.

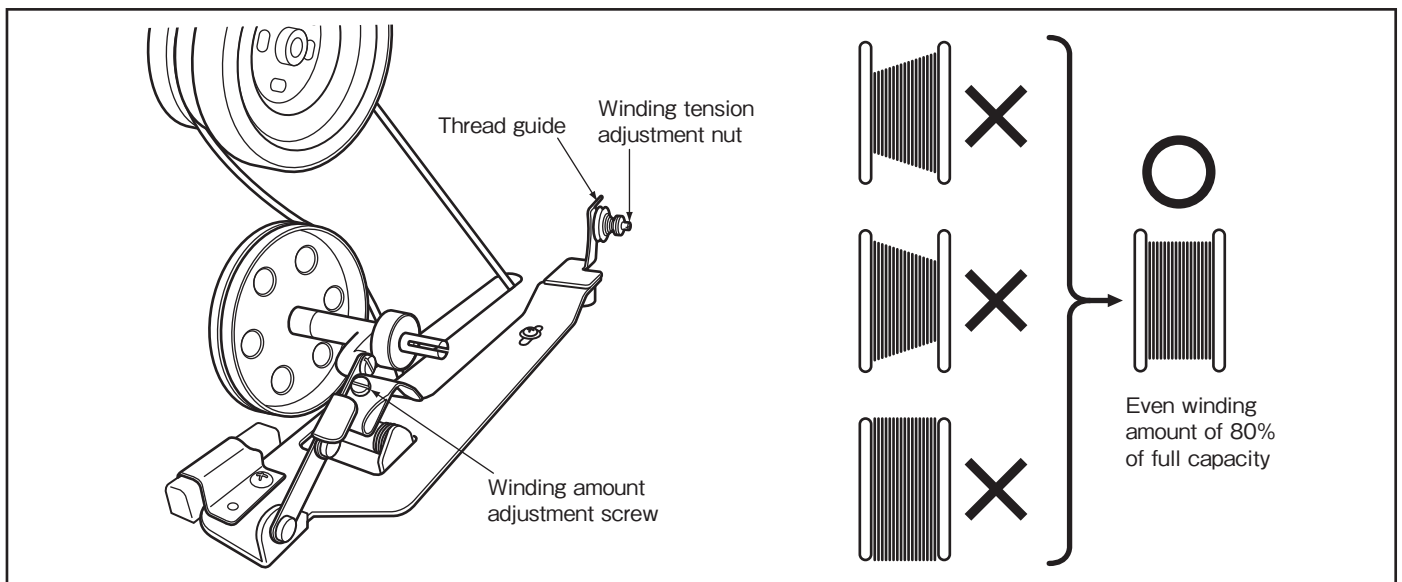

HOW TO USE

3 Selection of the thread

It is recommended to use "S" twist thread in the left needle (viewed from front), and "Z" twist thread in the right needle.

When discriminate use of needle threads is impossible, use "Z" twist thread in both the needles.

For bobbin thread, "S" twist thread as well as "Z" twist thread can be used.

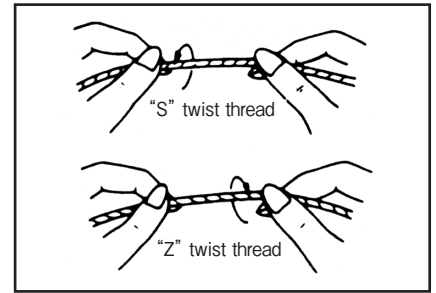

4 Threading of needle threads

1. Pass each needle thread through thread guide (A).
Note: When thin slippery thread (polyester thread or filament thread, etc.) is used,
Pass the thread through thread guide (B) as well.
2. With the thread take-up lever located at the upper most position, pass each needle thread in the order shown in the following figure.
Note: Pushing the needle thread tension releasing button shown in the figure below opens the saucer of the needle thread tension adjuster, and the needle thread can easily pulled out.

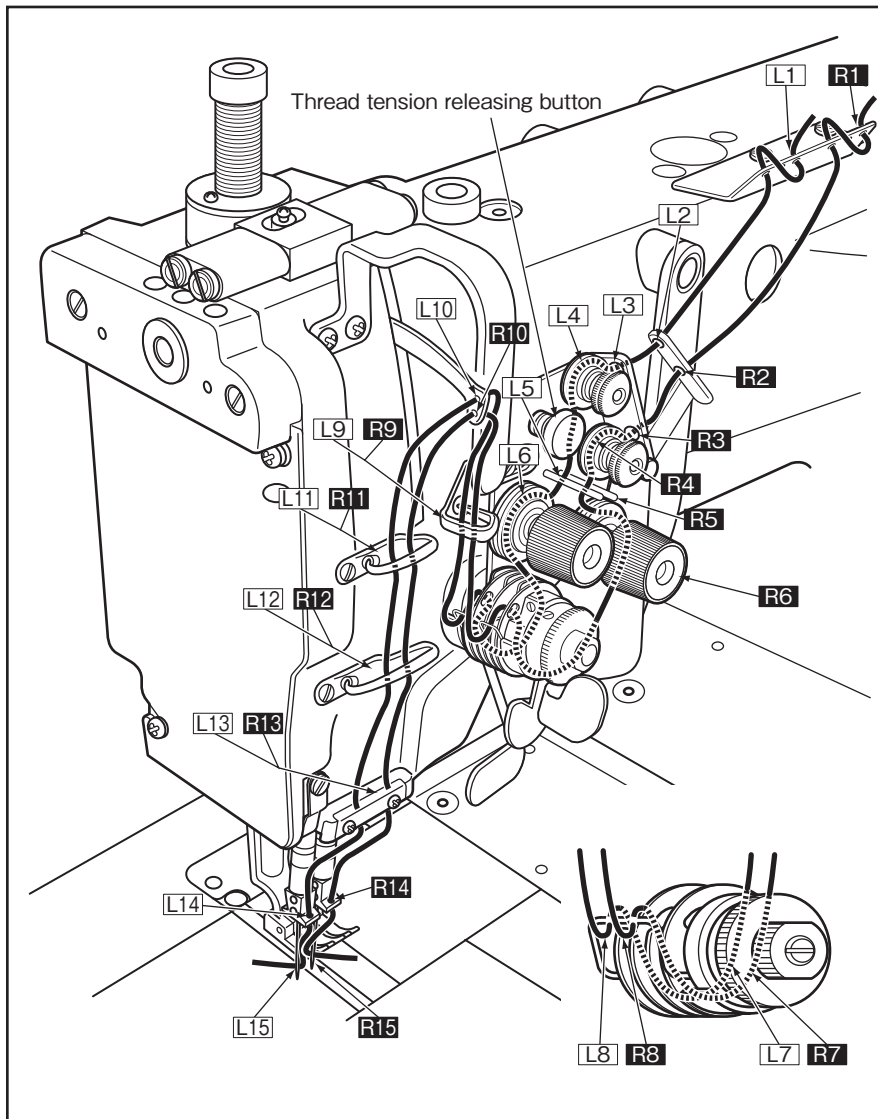
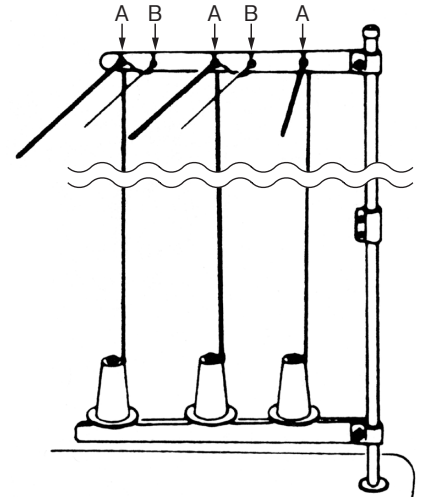

Note: When needles of small gauge (#11 or less) are used, each needle thread should be wound about 3/4 rotation around needles and then passed through needle eyes as shown in the figure, to assure neat stitches. It is recommended to use stepped needle.

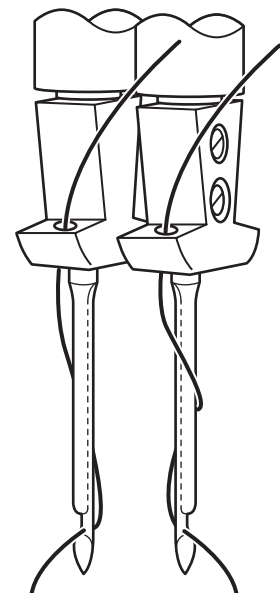

HOW TO USE

3. If the strong twisted thread (nylon or Tetron, etc.) is used and needle threads tension is strong (about 500gf or more), the right thread may be released from the thread tension disc. In this case, thread only the right thread as shown in the figure (keep the left thread standard).

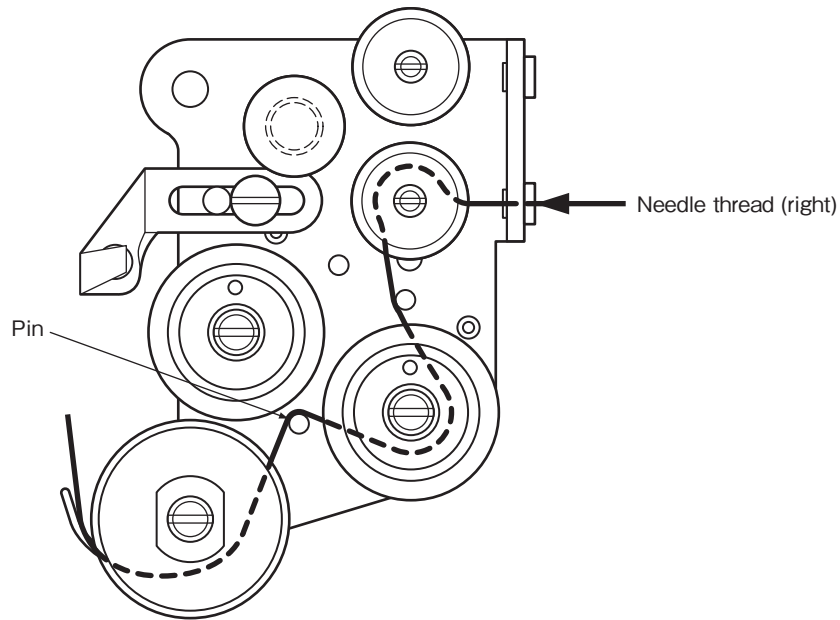

HOW TO USE

5 Adjustment of feed (stitch) length and backstitch

- Adjustment of feed (stitch) length...Adjust feed length by turning the feed length setting dial while pushing PUSH lever.
- Backstitch...Direction of stitching can be reversed by depressing the reverse sewing lever or pushing the touch back switch.

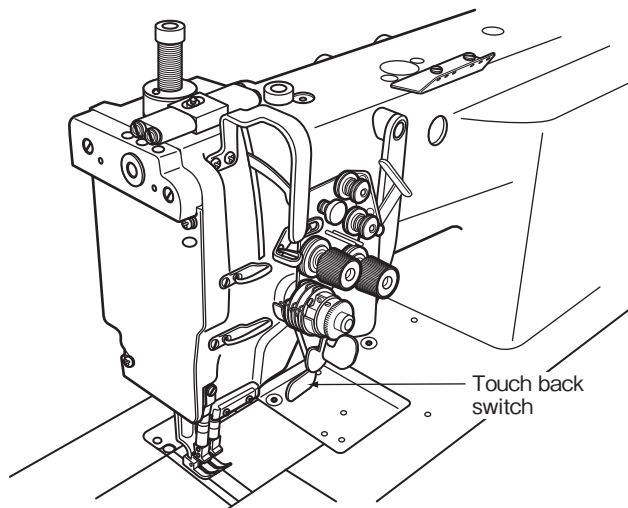
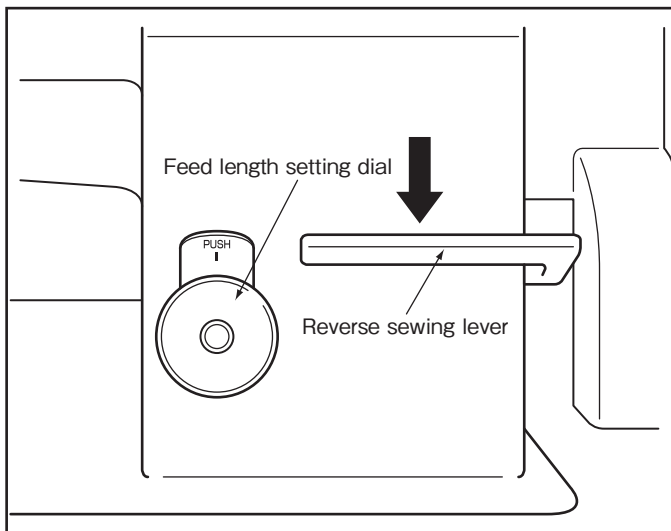

6 Adjustment of the needle thread guide

Adjust the needle thread guide of the needle thread tension adjuster according to the fabric, the thread, and sewing condition.

Needle thread guide position	Left side	Center	Right side
Fabric	Heavy	Standard	Light
Needle thread supply	More	Standard	Less

7 Setting of bobbins

Threading in the rotating hook (with tension spring) and installation of the bobbin case

- (1) Pass the bobbin thread slit ① so that the thread can be unwound on the left side of the bobbin.
- (2) Pass the bobbin thread in the order from ① to ④ in the figure.
- (3) Match the protruded portion of the rotating hook with recessed portion ① of the bobbin case and install the hook and the bobbin case to the rotating hook shaft.
- (4) Set the bobbin case latch lever.
- (5) Leave the thread tail on the bed.

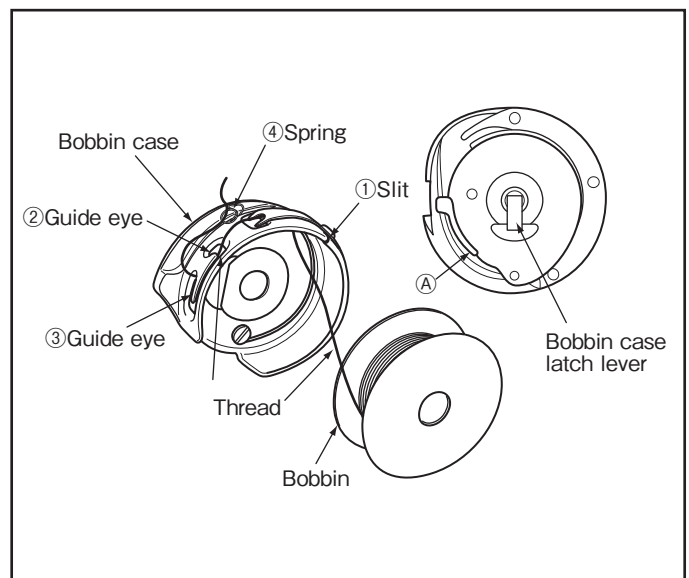

HOW TO USE

8 Threading of bobbin threads

(1) Extend the bobbin thread above the bed.

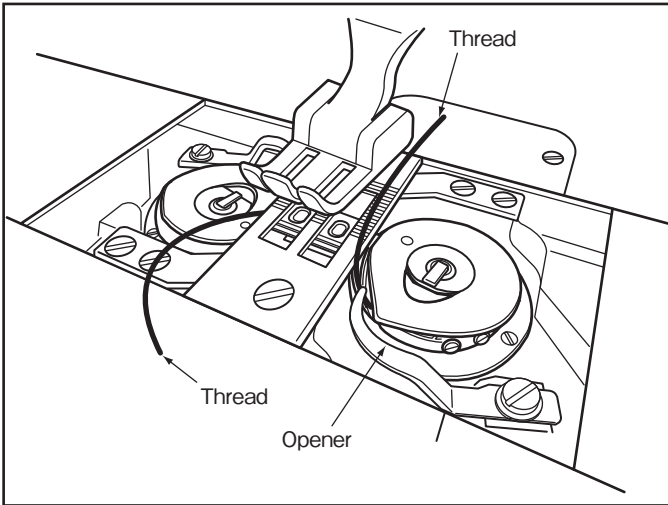

(2) While holding two needle threads with your left hand, turn the pulley one rotation with your right hand. The bobbin threads will come up when needle threads are lifted up as shown in the figure. Needle threads and bobbin threads should be aligned and led backward together.

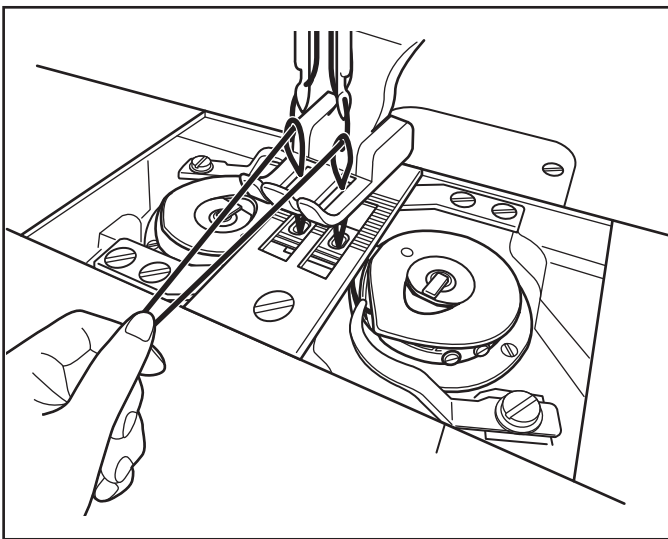

9 Adjustment of bobbin threads tension

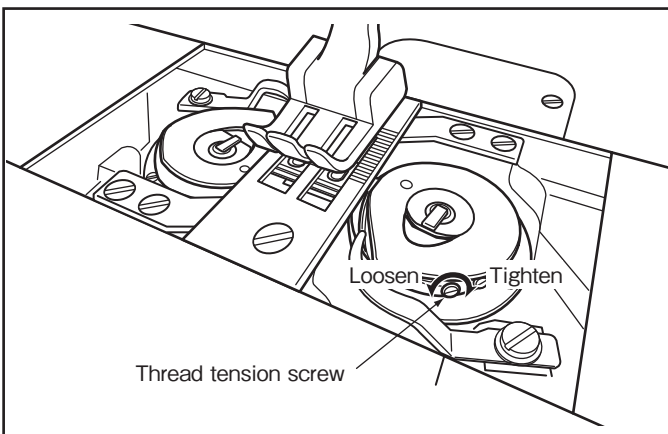

10 Adjustment of needle threads tension

Adjust needle threads tension by turning thread tension nuts.

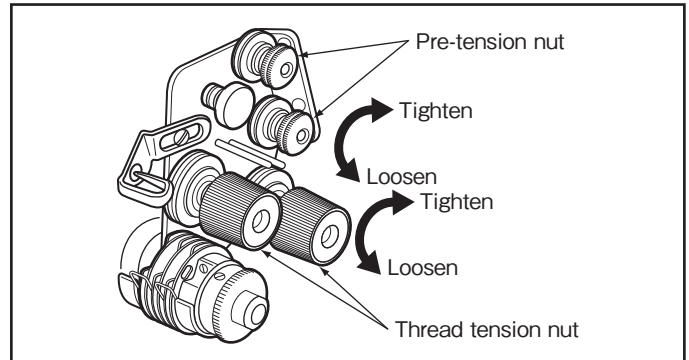

11 Adjustment of the thread take up spring

1. Adjusting movable range of the thread take up spring

- (1) To adjust the thread take up spring ① for the left thread, loosen the stopper stop screw ② and move the stopper ③.
- (2) To adjust the thread take up spring ④ for the right thread, loosen the stopper stop screw ⑤ and move the stopper ⑥.

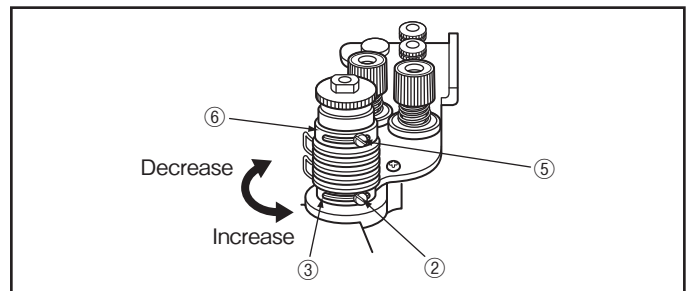

2. Adjusting intensity of the thread take up spring

- (1) Left thread:
Loosen the lock nut ⑦, and remove the face plate. Loosen the screw ⑪ in the arm. Turn the adjusting shaft ⑧. After adjustment, tighten the screw ⑪, and tighten the lock nut ⑦.
- (2) Right thread:
Loosen the screw ⑨, and turn the adjusting nut ⑩. After adjustment, tighten the screw ⑨.

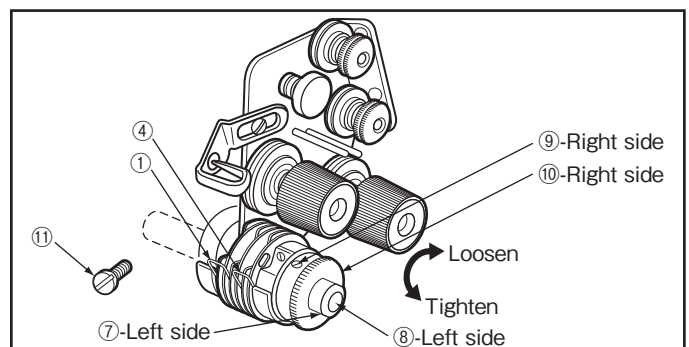

HOW TO USE

12 Timing between the rotating hook motion and the needle motion

Adjust right and left timing in the same way at the same time.

Note: If you remove the presser foot, the throat plate, and the feed dog, it makes easier to adjust.

- (1) Set feed length to 4.5 mm.
- (2) Loosen two screws (A), and remove the link.
- (3) Loosen all screws (B), (C), (D), (E), and slide each hook saddle to outside.

Note: At this time, don't loosen the set screw (D) too much.

- (4) Check that the first screw of the large gear enters a notch, and set the needle bar at the lowest position.
- (5) Slide the large gear to the hook saddle and mesh with the small gear. At this time, adjust it so that one of three set screws (E) faces upward.
- (6) Lift the needle bar 2.4 mm from the lowest position, and adjust the saddle hook position so that the gap between the tip of the hook and the scarf of the needle is 0.05 mm or lower.
- (7) Tighten screws (B), (C).
Note: Be careful not to overtighten screws (C).
- (8) Have a small gap between the large gear and the saddle hook, and tighten all set screws (D).
- (9) Lift the needle bar 2.4 mm from the lowest position again, and adjust the tip of the hook position so that it is in the center of the needle.
- (10) While checking that the tip of the hook is in the center of the needle, and tighten set screws (E).

Note: Tighten each screw (E) little by little.

- (11) Install the link with the screws (A) as before.
- (12) Return the machine head to the original position and adjust the needle guide position so that it come lightly in contact with the needle.

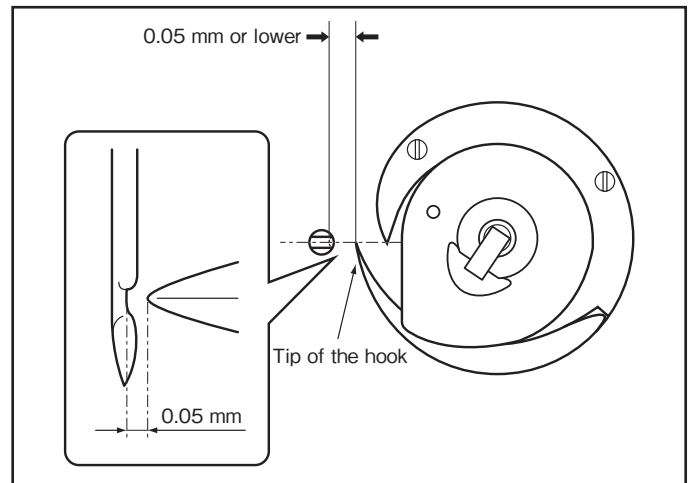
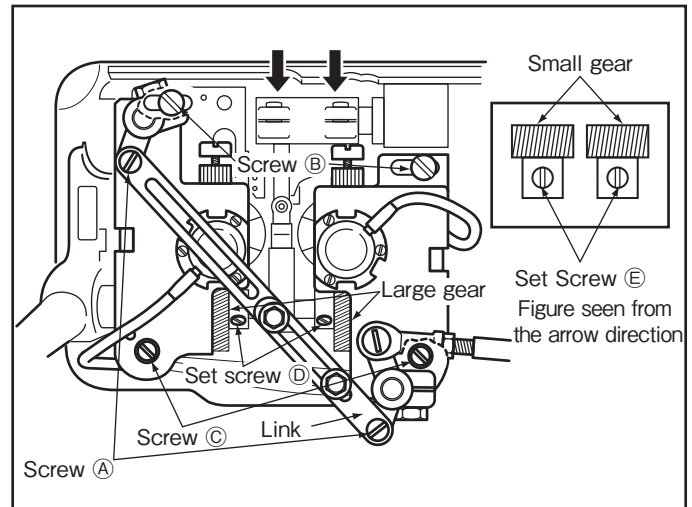

HOW TO USE

• Adjustment of the needle up and down position

When the needle is lifted 2.4 mm from the lowest position, adjust the needle position so that the gap between the top of needle eye and the tip of the hook is 1.0 to 2.0 mm.

- (1) Remove the set screw ①.
- (2) Rotate one turn the needle clamp ② (Adjustment pitch is 0.6 mm), or rotate half turn the stopper ③ with taking off the set screw ④ (Adjustment pitch is 0.3 mm).
- (3) Return the needle clamp ② to the position before adjusting and fully tighten the set screw ① and ④.

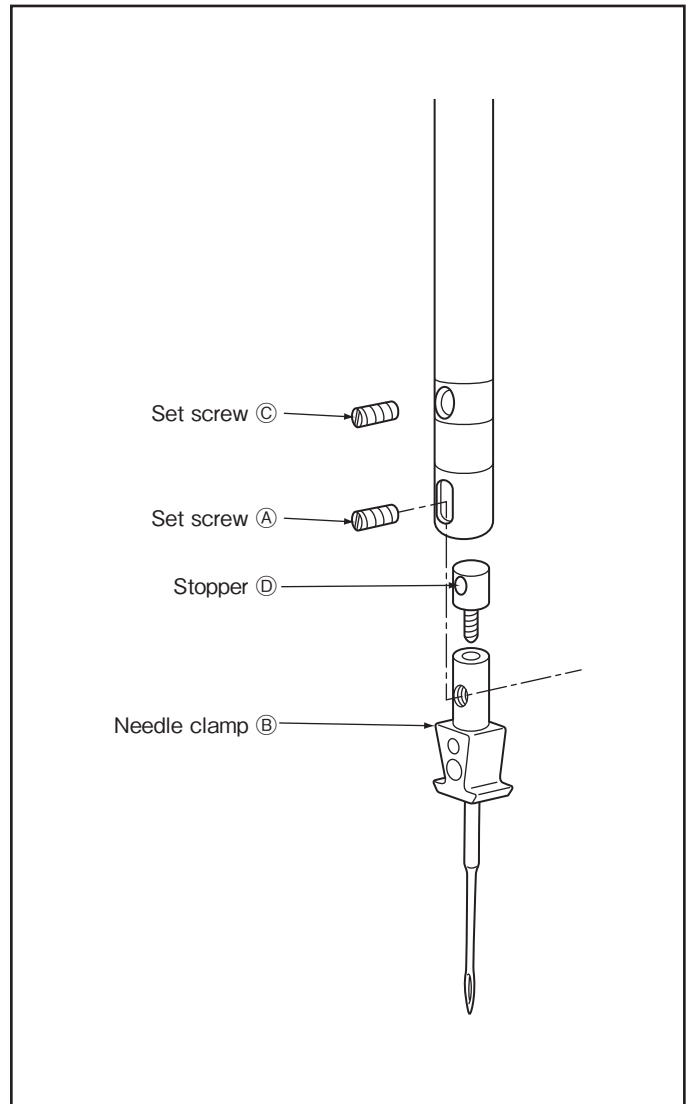

13 Adjustment of the presser foot pressure

Adjust the presser foot pressure by turning the pressure adjusting screw.

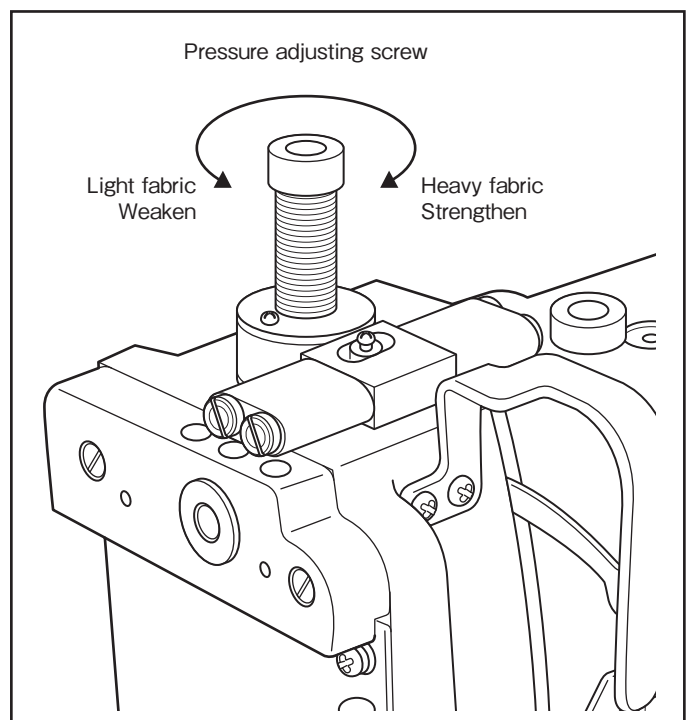

HOW TO USE

14 Adjustment of the feed dog height

The feed dog height and the presser foot pressure must be adjusted according to the fabric.

- ◆ The fabric will be damaged if the feed dog extends too high, or if the presser foot pressure is too large.
- ◆ An even stitch length cannot be assured if the feed dog is too low, or if the presser foot pressure is too small.
- ◆ The feed dog height is the position where the needle is at the top position.

Adjustment of the feed dog height

- (1) Lean the machine head backward.
- (2) Turn the pulley by hand and stop it at the position where the feed dog rises to the maximum height.
- (3) Loosen the feed bar screw.
- (4) Vertically move the feed bar (in the direction indicated by the arrow in the figure) to adjust it to an adequate height.
- (5) After adjusting, tighten the feed bar screw.

The feed dog height is factory-adjusted to 1.2 mm.

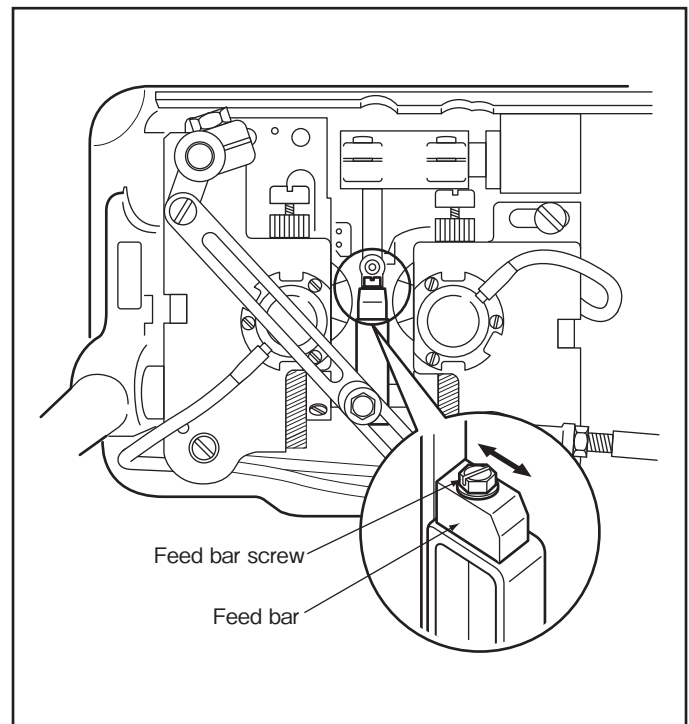
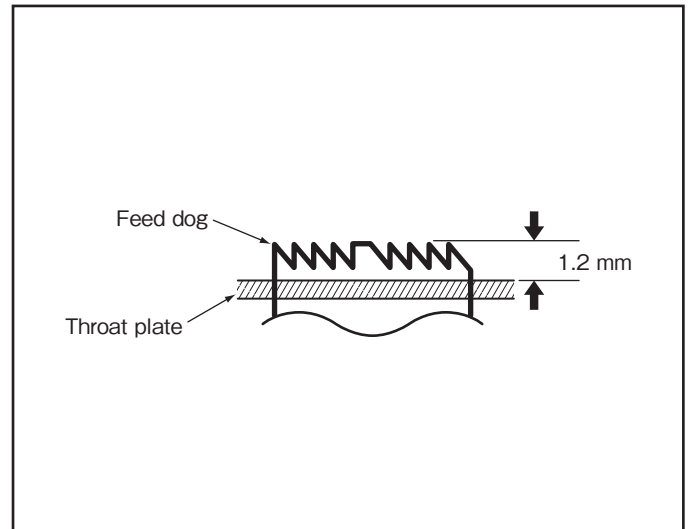

HOW TO USE

15 Relationship between the rotating hook motion and the thread take-up lever motion

When the timing belt is removed for replacement, etc., the relation between the rotating hook motion and the thread take-up lever motion should be adjusted as follows:

- (1) Turn the pulley and stop when the thread take-up lever is lifted to the highest position.
- (2) Lean the machine head backward and check that the arrow (timing mark) put on the timing belt is aligned with the black line on the boss of lower shaft bearing.
- (3) If the timing mark is not in line with the black line, remove the timing belt and install it again to adjust.

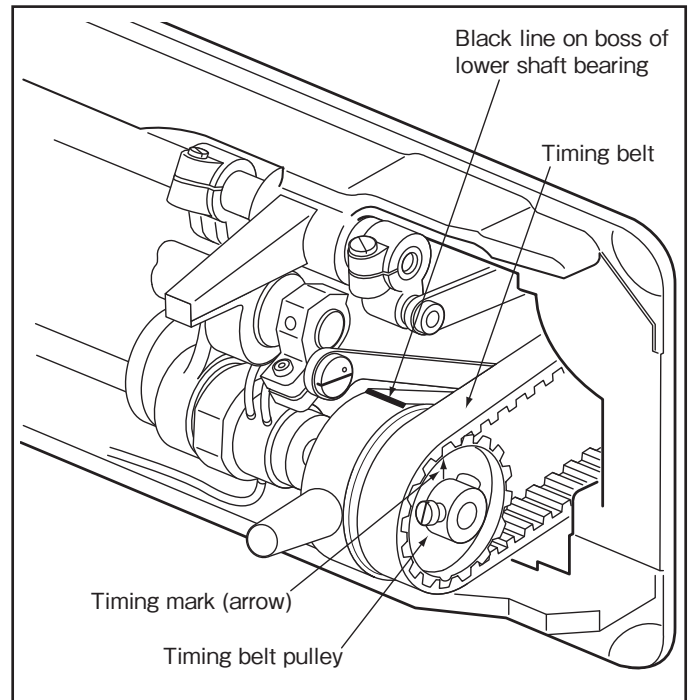

16 Relationship between the rotating hook motion and the opener motion

- (1) Turn the pulley by your hand and stop it at the position where the opener holder is located most remotely from the throat plate.
- (2) Check that the gap between the lug **A** and the opener is approximately 0.2 mm.
- (3) If the gap is too large or small, loosen the opener holder screw **B** and adjust position of the opener.

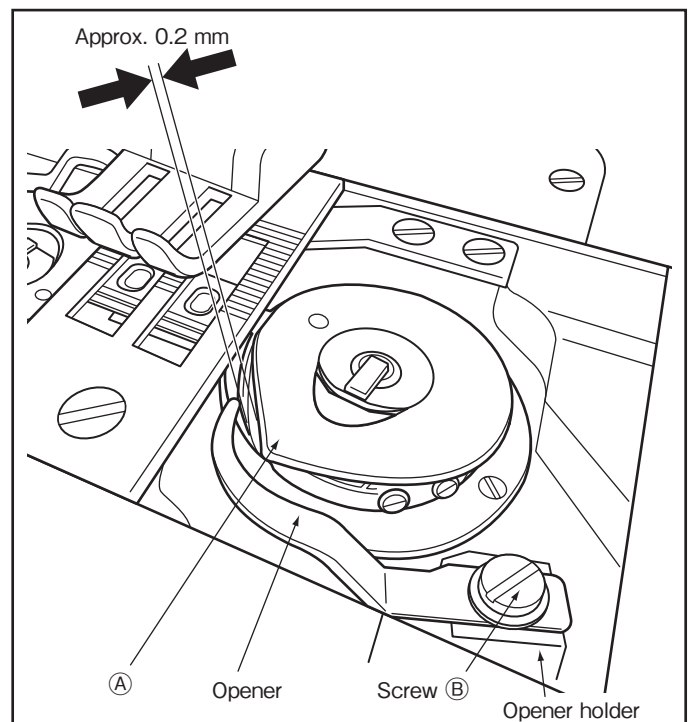

HOW TO USE

17 Relationship between the needle motion and the feed dog motion

- (1) Set the stitch length to "0" on the feed length setting dial.
 - (2) Set the needle at the lowest position.
 - (3) Lean the machine head backward.
 - (4) Loosen the feed rock shaft crank set screws (A), (B).
 - (5) Adjust the distance between the pressure bar and the needle bar to 14.1 mm and temporarily tighten the feed rock shaft crank set screws (A), (B).
 - (6) Check that the feed rock shaft crank (right) is connected with the link at a right angle as shown in the figure.
 - (7) If the connection is not a right angle, remove the Rear cover, loosen screw (C) and move the link to connect the feed rock shaft crank (right) with the link at a right angle.
 - (8) After adjusting, fully tighten all screws (A), (B), (C).
- At this time, check that the needle enters the hole at center of the feed dog.

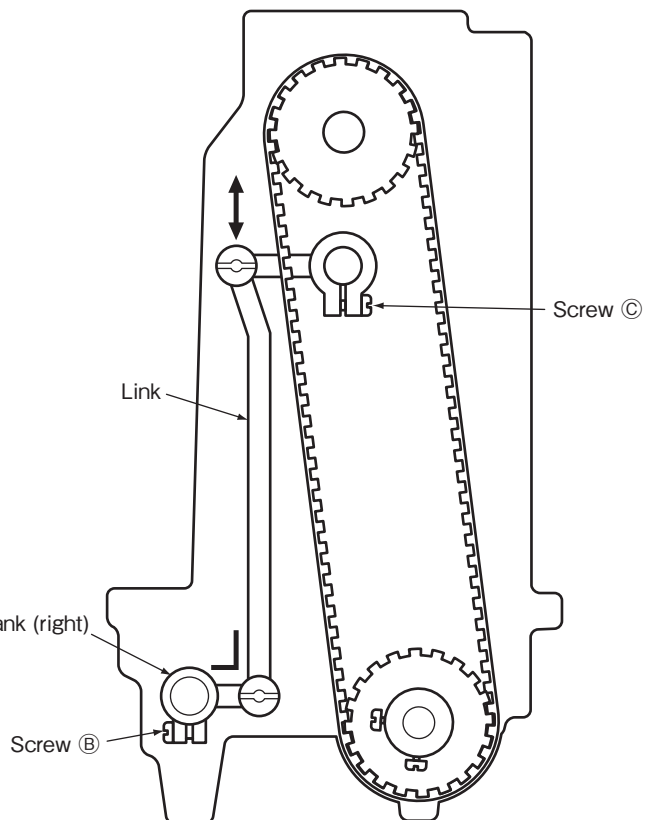
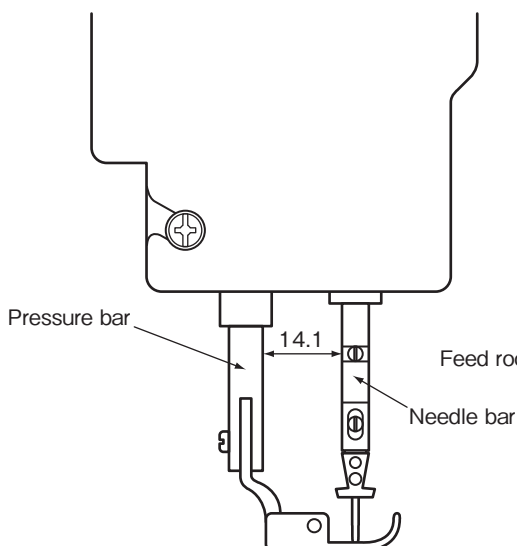
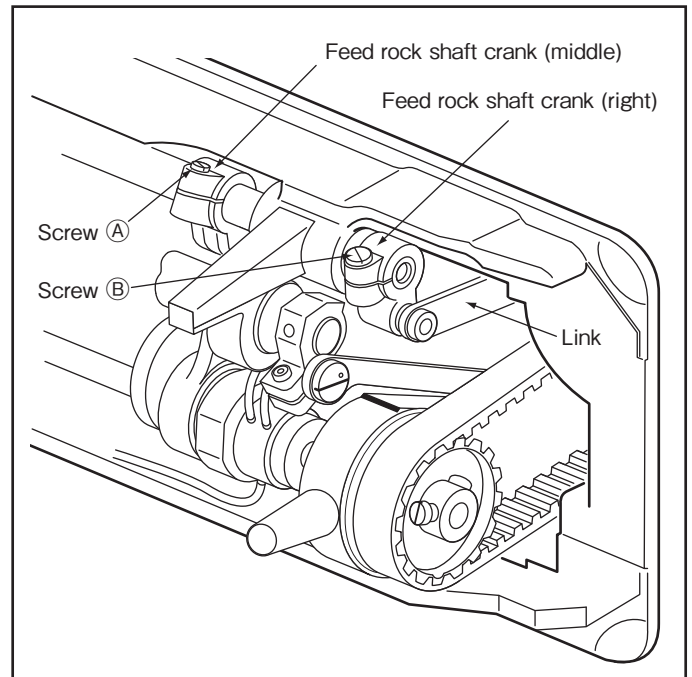

HOW TO USE

18 Operation of the needle bar (left or right)

● The stop lever should be set to “L” or “R” position.

(1) Left needle bar stop operation

Move the stop lever to “L” position to stop the left needle bar.

(2) Right needle bar stop operation

Move the stop lever to “R” position to stop the right needle bar.

(3) Double needle bar operation

To change single-needle (left or right) operation to double-needle operation, depress the push lever backward. The stop lever will automatically return to “0” position and double-needle operation becomes possible.

Note: Before operating the stop lever, check that the needle bar position is set at the lowest position and the machine is stopped operation.

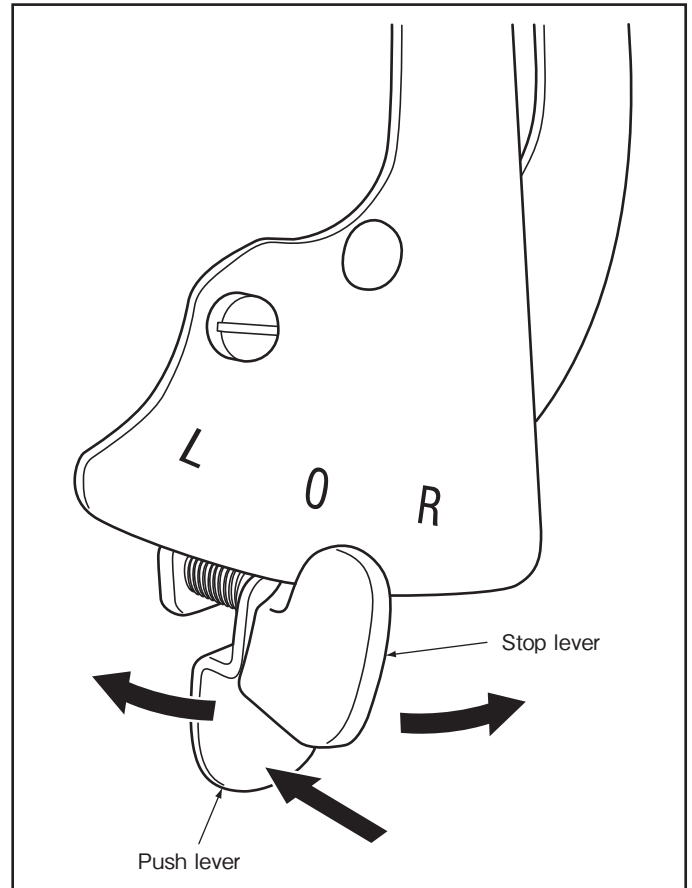

19 Relationship between angle of the corner stitching and stitch length

(1) In order to assure neat corner stitching, stitch length should be determined in reference to angle of corner stitching from the following table (applicable only to 1/4 needle gauge).

(2) By determining stitch length of inside stitching for a given angle of corner stitching, the number of outside corner stitches can be identified from the table.

(3) For example: When stitch length of 40° corner stitching is determined to 2.9 mm, the number of stitches is “6”.

Relationship between stitch length and number of stitches (applicable only to 1/4 needle gauge)

Angle of corner stitching \ Number of stitches	2	3	4	5	6	7	8
30°				4.8	4.0	3.7	3.0
40°			4.4	3.5	2.9	2.5	2.2
50°		4.6	3.4	2.7	2.3	2.0	1.7
60°	5.5	3.7	2.8	2.2	1.9	1.6	
70°	4.6	3.0	2.3	1.8	1.5		
80°	3.8	2.5	1.9	1.5	1.3		
90°	3.2	2.1	1.6	1.3			
100°	2.7	1.8	1.3				
110°	2.2	1.5					
120°	1.8	1.2					
130°	1.5						
140°	1.1						

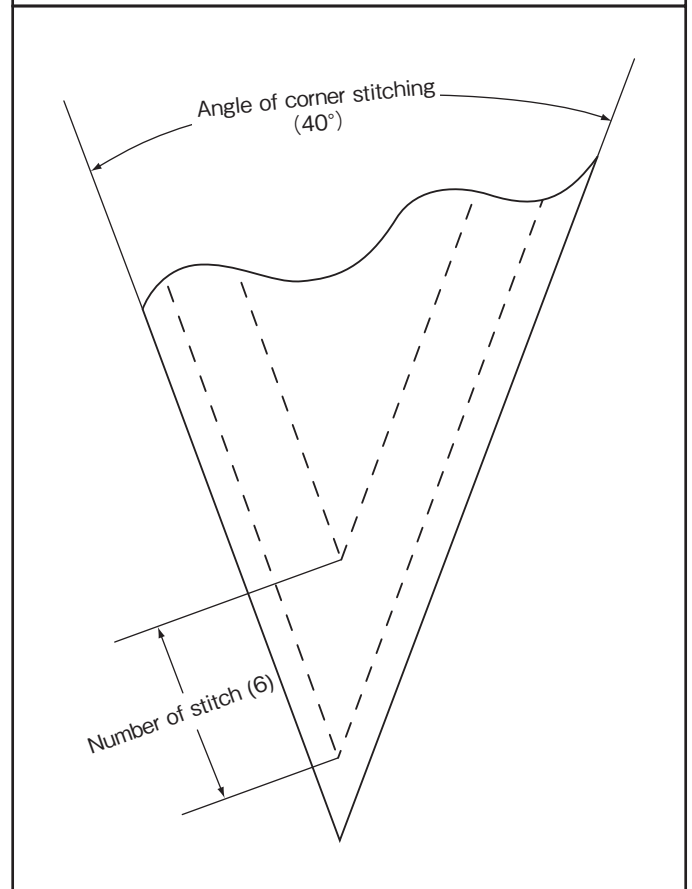

HOW TO USE

20 Adjustment of the corner stitching device "0" position

(1) When the stop lever is set "0" position, adjust so that the gap A and B between the cam and two hinged pins of the needle bar guide bracket are equal as follows.

① Rough adjustment:

Adjust so that the center distance between two holes of the stud bolt is 115 mm by loosening the nut and turning the stud bolt.

② Fine adjustment:

Loosen the guide pin set screw (A), and set so that the gap A and B between the cam and two hinged pins are equal.

(2) After adjusting, move the stop lever to "L" or "R" position, and check that the corner stitching device work correctly.

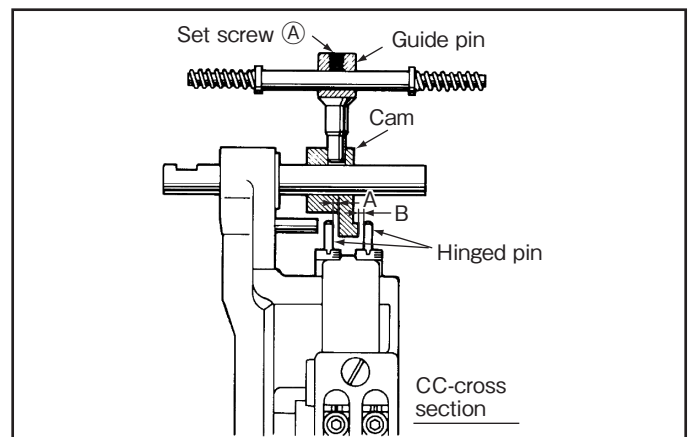
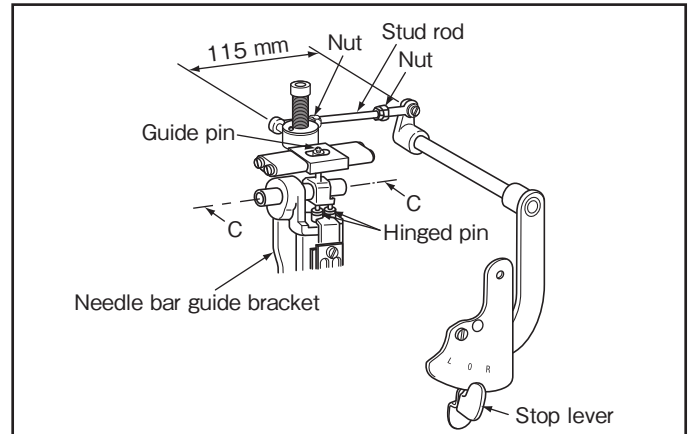

21 Adjustment of the corner stitching device / height of the needle bar

If one needle stop isn't working correctly in "L" or "R" position, adjust height of the needle bar as follows.

(1) Remove the face plate and the rubber plug.

(2) Move the needle bar to the position where the screw of the needle bar crank rod is able to be adjusted by turning the pulley.

(3) Loosen the screw.

Note: Be careful not to loosen the screw too much.

(4) Turn the pulley and stop it at the position where the needle bar comes to the highest position.

(5) Adjust the eccentric bushing, and tighten the screw.

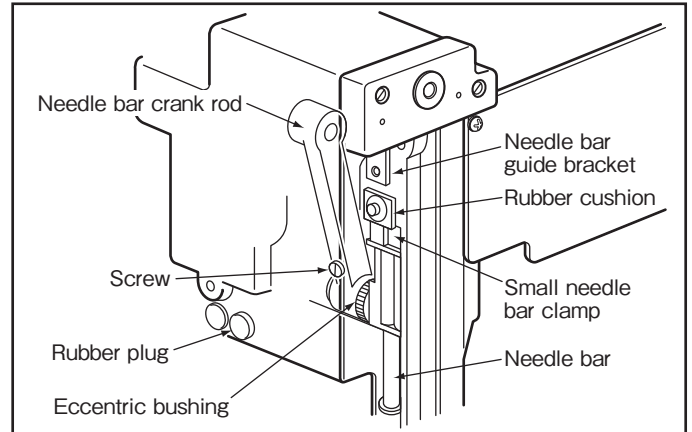

Working contents	How to adjust	
When one needle stop isn't enough (When the stopping needle bar fallen)	Lift the needle bar	<p>Lower a notch of the eccentric bushing.</p>
○When the needle bar that stopping wobbled ○When the small needle bar clamp contact the rubber cushion of the needle bar guide bracket strongly and the machine torque become heavier	Lower the needle bar	<p>Raise a notch of the eccentric bushing.</p>

HOW TO USE

22 Installation position of the feed cam

- (1) Set the feed length setting dial to maximum.
- (2) Turn the pulley and stop it at the position where the red mark point on the pulley meets the black mark point on the arm.
- (3) Move the feed cam to the position shown in the figure, and repeat the forward stitch and the backward stitch.

At this time, set the feed cam to the lower shaft at the position where the needle (feed dog) stops.

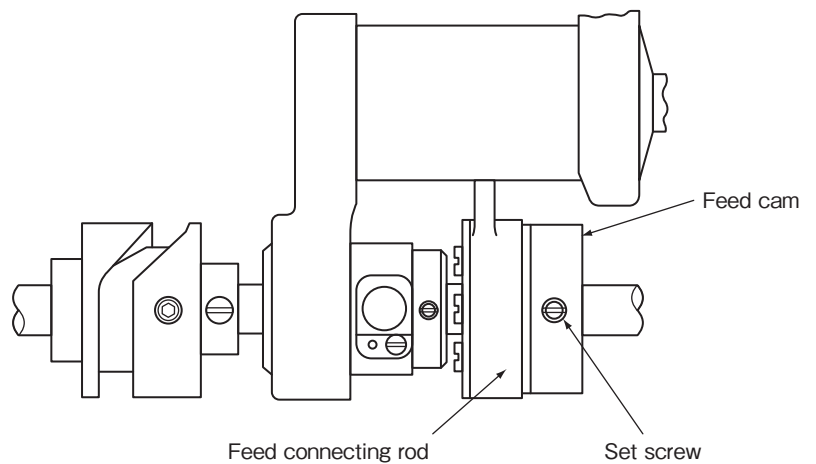
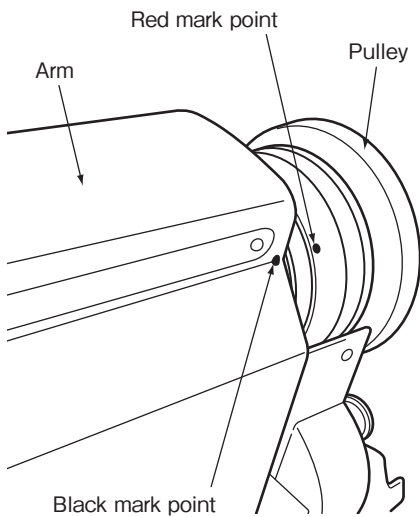
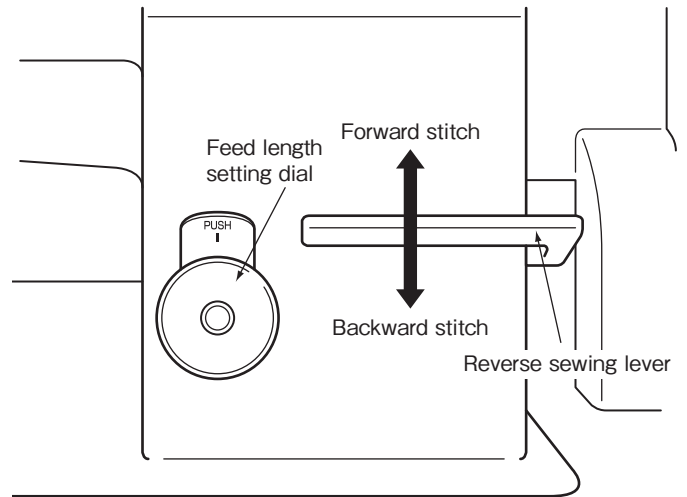

23 Adjustment of forward/backward feed length

The forward/backward feed length can be adjusted by moving the eccentric pin as shown in the figure.

- (1) Loosen the reverse stitch shaft crank screw.
- (2) To increase forward stitch length, turn the eccentric pin clockwise.
- (3) To increase backward stitch length, turn the eccentric pin counterclockwise.

Note: Please adjust in the range where the mark point of the eccentric pin is facing to the reverse block side as shown in the figure.

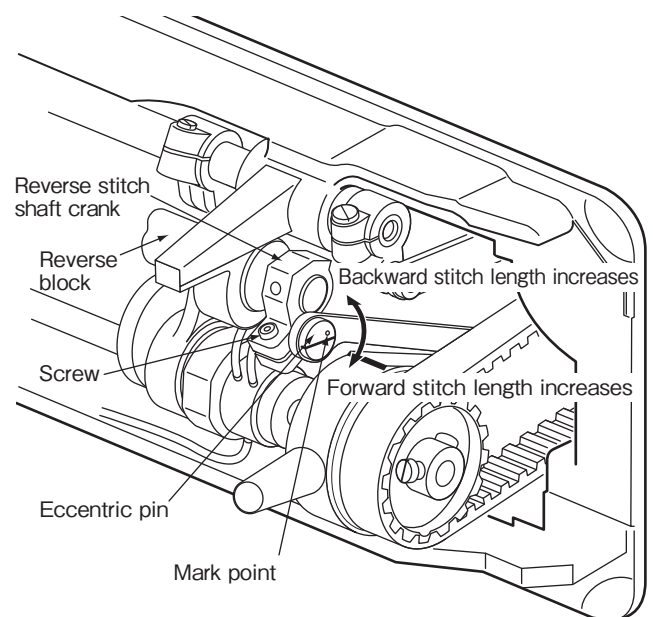

HOW TO USE

24 Installation of the movable knife

1. Initial position of the movable knife

- (1) Turn the pulley and stop it at the position where the needle comes to the lowest.
- (2) Put the cam roller into the thread trimmer cam groove by pushing the cam follower crank.
- (3) In this condition, turn the pulley and stop it at the position where the black mark point on the arm meets the white mark point on the pulley.
Set the cam follower crank at this position with a screwdriver temporarily preventing the cam roller coming out from the cam groove.
- (4) Loosen bolts Ⓐ and Ⓑ.
- (5) Adjust so that the tip slant portion of the movable knife protrudes 0 to 0.5 mm from the fixed knife, as shown in the figure and tighten bolts Ⓐ and Ⓑ.

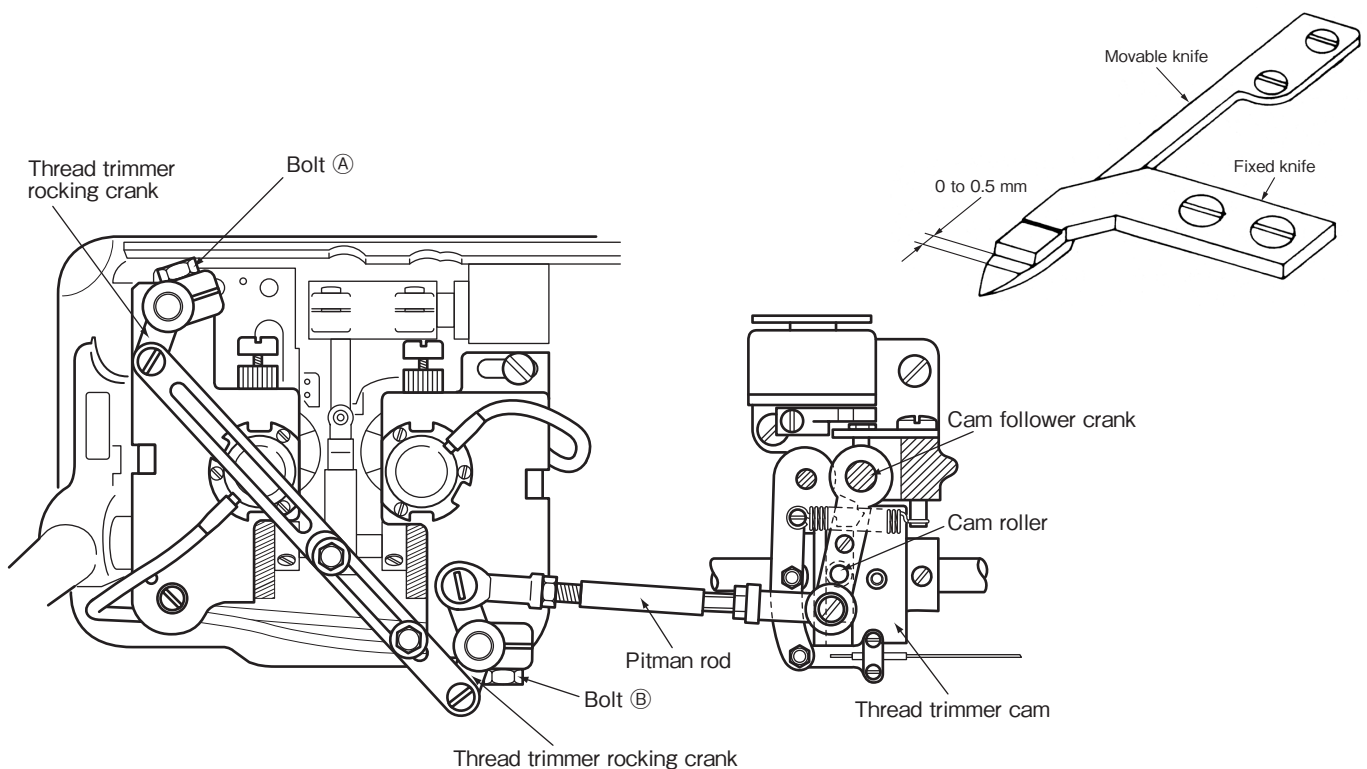

2. Gap between the movable knife and the lug of inner hook

- (1) Turn the pulley and stop it at the position where the needle comes to the lowest.
- (2) While pushing the cam follower crank, turn the pulley and stop it at the position where the movable knife move to the position as shown in the figure.
- (3) Turn the inner hook and adjust so that the gap between the movable knife and the lug of inner hook is about 0.5 mm (screws Ⓐ and Ⓑ should be loosened for this adjustment).

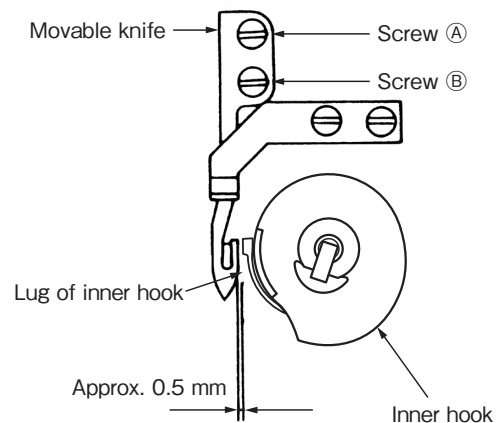

HOW TO USE

25 Installation position of the thread trimmer cam

- (1) Adjust so that the gap between the lower shaft bushing (middle) and the bushing is 6 mm and then tighten the screw ① to the flat on the lower shaft.
- (2) Place the thread trimmer cam on the end face of the bushing and the thread tension releasing cam on the end face of the thread trimmer cam (making the gap between each part zero), then tighten each screw.

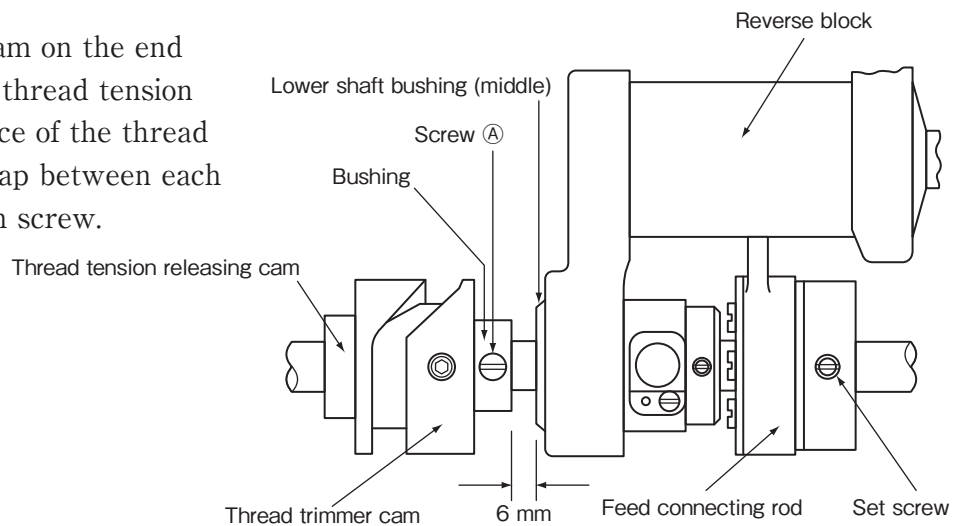

26 Adjustment of the thread trimmer cam

- (1) Turn the pulley and stop it at the position where the needle comes to the lowest.
 - (2) Put the cam roller into the thread trimmer cam groove by pushing the cam follower crank.
 - (3) Turning the pulley, adjust the thread trimmer cam so that the movable knife starts moving when the green mark point on the pulley comes in line with the black mark point on the arm.
- To adjust, loosen two thread trimmer cam clamp screws ①.

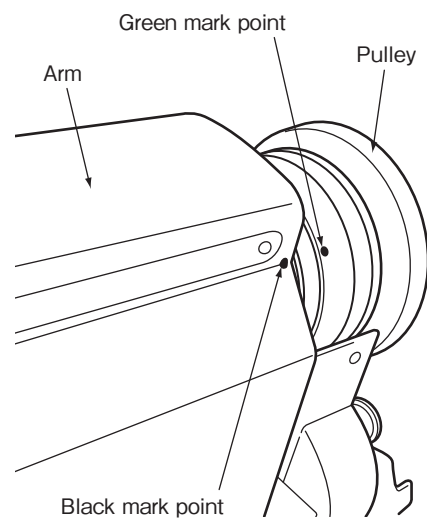
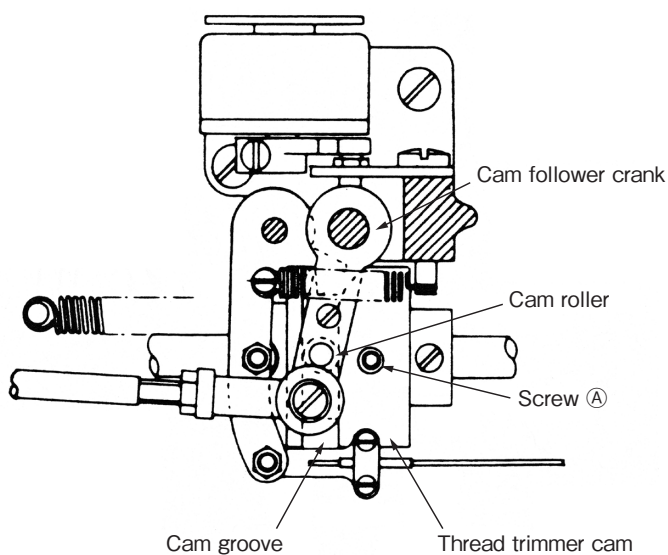

HOW TO USE

27 Adjustment of the holding pressure of the bobbin thread

- (1) Loosen the set screw ② for clamping the adjuster ①. (By using the socket wrench 1.5 in accessories.)
- (2) When the adjuster ① is moved upward, the holding pressure becomes weak. On the other hand, when the adjuster ① is moved downward, the holding pressure becomes strong.
- (3) Set the adjuster ① to the position where it can be gotten an adequate holding pressure of the bobbin thread. (At this time, the leaf spring ③ should be located in directly below the leaf spring ④.)
- (4) Tighten the set screw ②.

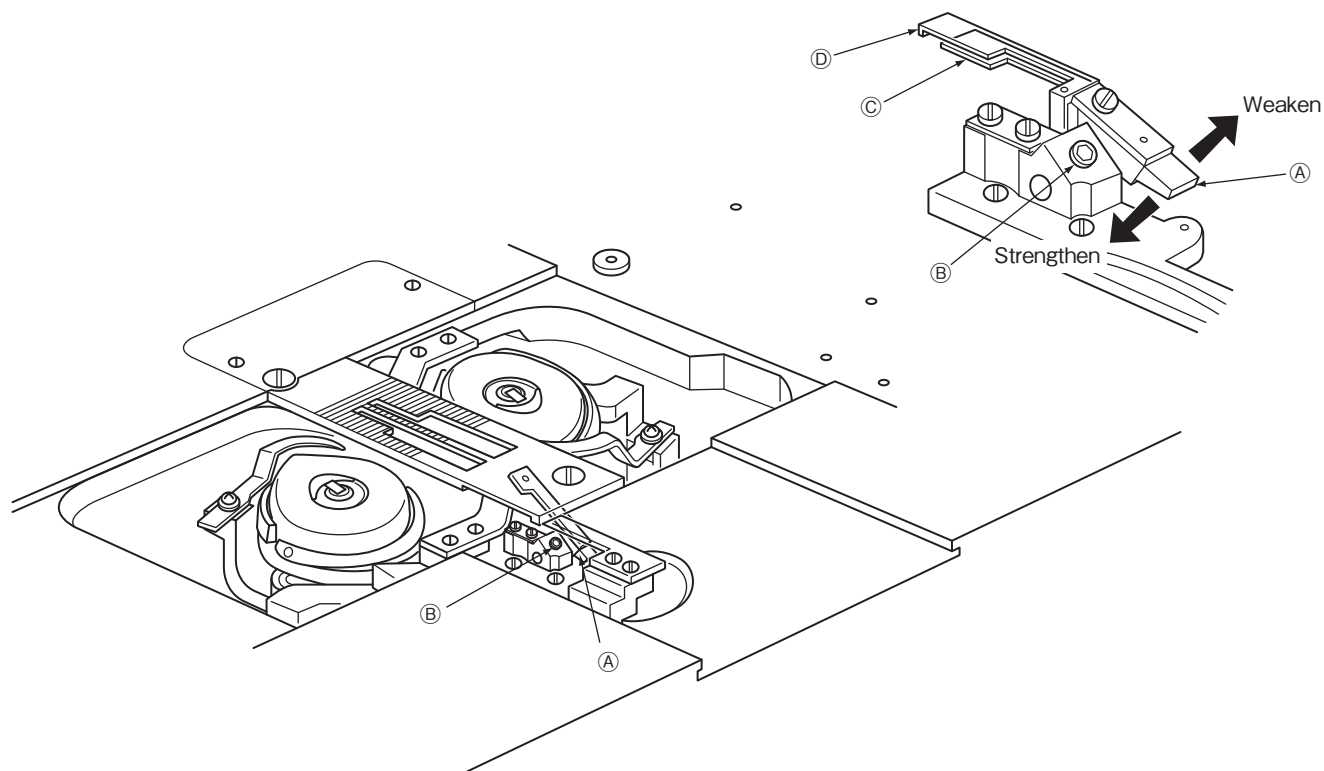

HOW TO USE

28 Adjustment of the thread tension releasing

- (1) Turn the pulley and stop it at the position where the needle comes to the lowest.
- (2) Put the cam roller into the thread trimmer cam groove by pushing the cam follower crank.
- (3) Turning the pulley, adjust the thread tension releasing cam so that the thread tension disc closes when the white mark point on the pulley comes in line with the black mark point on the arm.
To adjust, loosen two thread tension releasing cam clamp screws (A).
- (4) The opening amount of the thread tension disc should be adjusted with the thread tension releasing roller (B) mounted on the convex portion of the thread tension releasing cam, as shown in the figure.
To adjust, loosen screws (C) and pull the wire.
- (5) Make fine adjustments by loosening the nut (D).
- (6) Loosen the nut (D) and make the outer casing approach to the right to increase the opening amount.

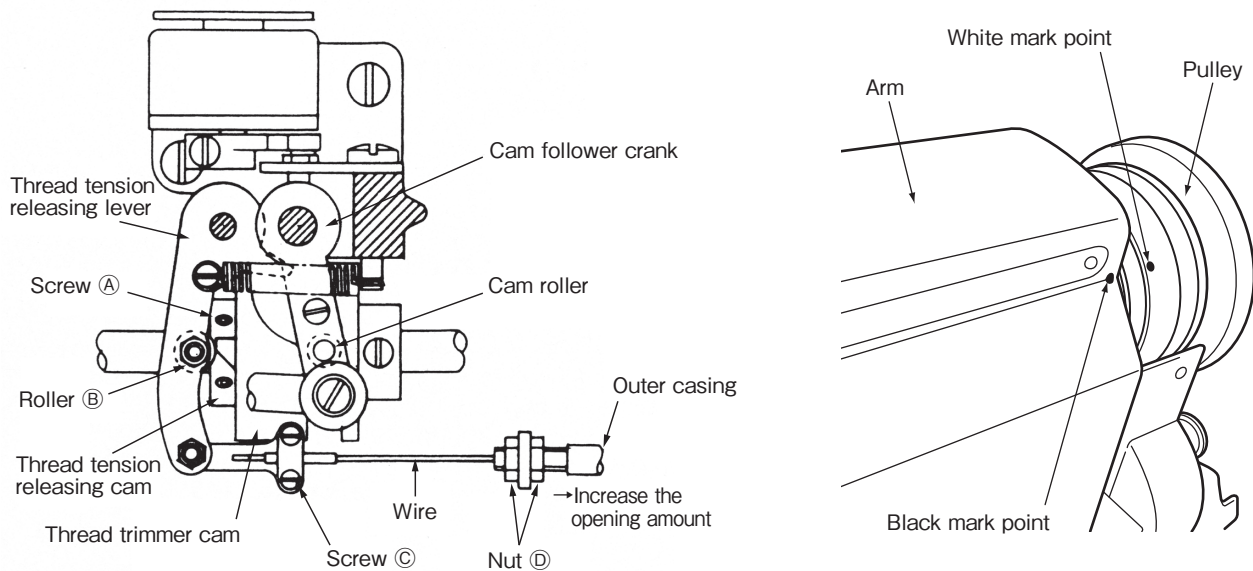

HOW TO USE

29 Adjustment of meshing pressure between the movable knife and the fixed knife

- (1) Loosen the fixed knife bracket clamp bolt ①.
- (2) Adjust meshing pressure by turning the up and down adjusting screw ②, and tighten the bolt ①.

Note: Since overpressure causes a large torque on the thread trimmer mechanism and trimming failure, adjust so that the thread can be trimmed with the minimum pressure.

- (3) Move the movable knife and check that the thread can be sharply trimmed.

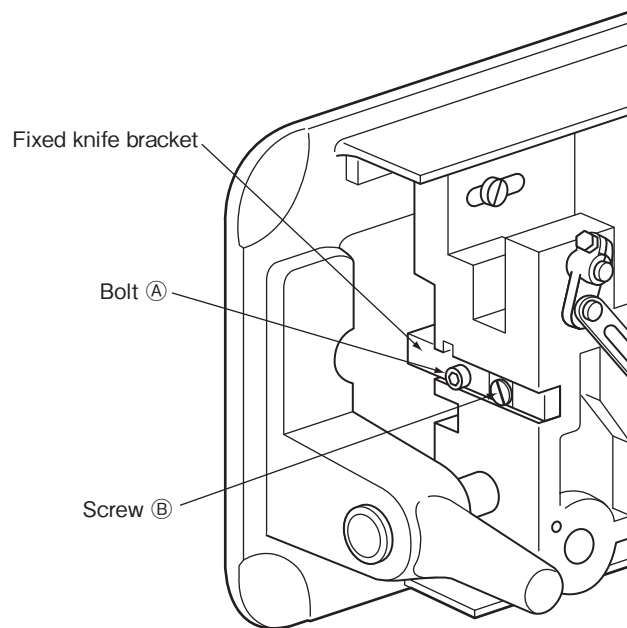

30 Sharpening of the fixed knife

If the fixed knife is dull, it should be sharpened as shown in the figure.

Since it is very difficult to sharpen the movable knife, replace it with a new one when it dulls.

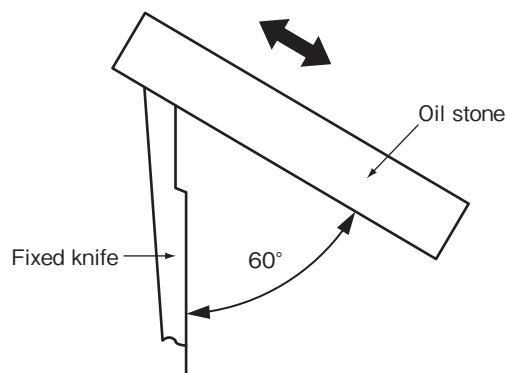

HOW TO USE

31 Adjustment of the thread trimmer with changing the width between needles

- (1) Replace the throat plate, the feed dog, the needle clamp, and the presser foot.
(Since the throat plate and the feed dog are special parts designed for the thread trimming machine, be sure to use those specified by us.)
- (2) Lean the machine head backward.
- (3) Loosen two link clamp bolts (J).
- (4) Remove the spring (M).
- (5) Loosen hook saddle clamp screws (A) and (B), and adjust the gap between the needle and the hook.
- (6) After adjusting the needle and the hook, install the spring (M).
- (7) Contact thread trimmer rocking cranks (C) and (D) to stopper pins (E) and (F), and tighten the Link clamp bolt (J).
- (8) Turn the pulley and stop it at the position where the needle comes to the lowest.
- (9) Loosen nuts (G) and (H).
- (10) Push the cam follower crank (K) and adjust the pitman rod (L) so that the cam roller can smoothly enter the thread trimmer cam groove.
- (11) Adjustment of the cam groove and the cam roller
 - a) Put the cam roller into the thread trimmer cam groove by pushing the cam follower crank (K).
 - b) Turn the pitman rod (L), and adjust the gap between the cam roller and the surface N of the cam groove as small as possible, and tighten nuts (G) and (H).
 - c) Push the cam follower crank (K) again and check that the cam roller enters the thread trimmer cam groove smoothly.

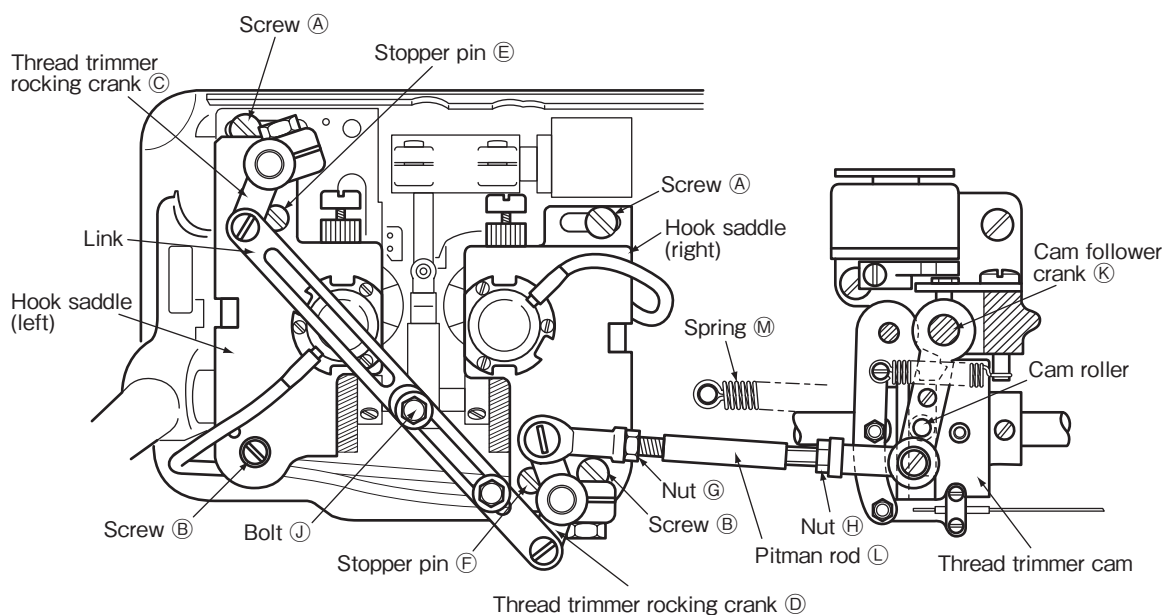
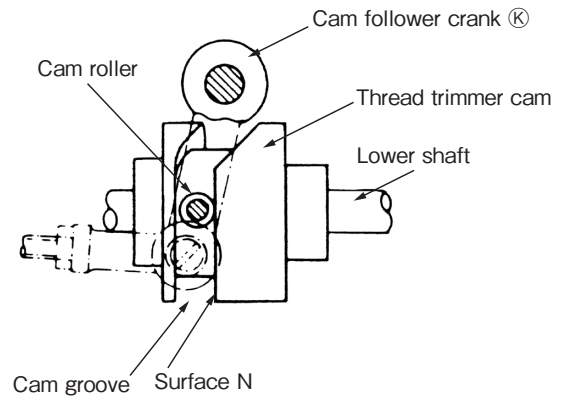

HOW TO USE

32 Installation of the solenoid arm

- (1) Install the rotary solenoid so that the gap between the rotary solenoid and the solenoid arm is about 0 to 0.5 mm.

Note: If the gap is too large, the roller and the cam follower crank interfere while rotating movement of the solenoid, which causes malfunction and result in failure of the thread trimmer device.

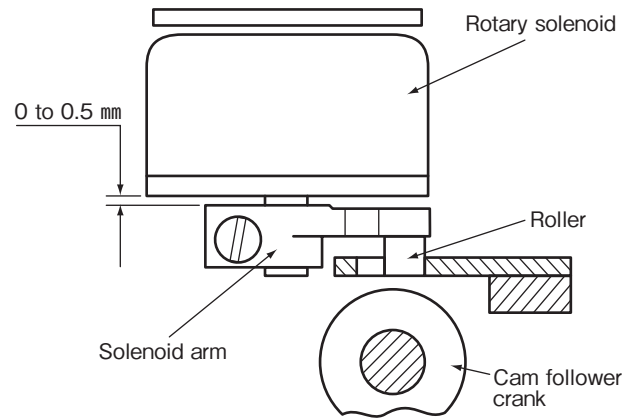

33 Removal procedure of the hook

- (1) Loosen three set screws of the small gear to the hook shaft.
- (2) Remove the opener.
- (3) Remove the fixed knife.
- (4) Move the lever to the arrow direction, and move the movable knife to the arrow direction.
- (5) Remove the hook.

Note: To install the hook, reverse the removing procedure.

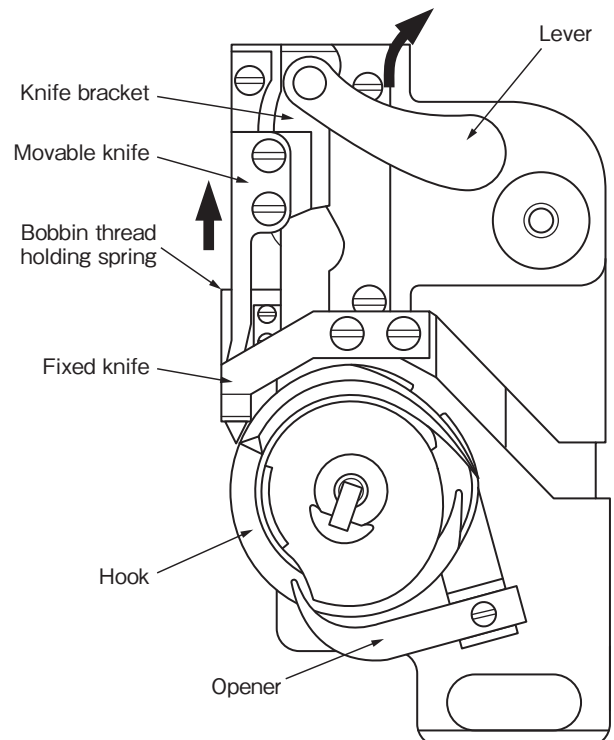

SPECIFICATIONS

LT2-2250-B1T Specifications

Specifications	Model	LT2-2250-B1T
Application		Medium-heavy material
Max. sewing speed (rpm)		3,000
Stitch length (mm)		0 to 7
Needle bar stroke (mm)		33.4
Thread take-up lever stroke (mm)		68.0
Presser foot stroke (mm)	Hand	7.0
	Knee	13.0
Needle		DP × 5 #18
Hook (horizontal rotating hook)		Large
Bobbin		Made of aluminum for thread trimmer
Lubrication system		Automatic lubrication
Thread trimmer method		Combination of fixed knife and movable knife
Touch back		○
Bed dimensions (mm)		517 × 178
Needle gauge (mm)	Standard	6.4
	Special	3.2、 4.8、 8、 9.5、 12.7

Note: ● Feed dog, throat plate, rotating hook, bobbin case, bobbin, and bed slide should be those designed for the thread trimmer.

- The bobbin should be of high quality free from deformation.
- Some materials, gauge sizes, and/or sewing conditions may require specifications other than those listed above.
- These specifications are subject to change for machine improvement.

MITSUBISHI ELECTRIC CORPORATION

Printed in Japan

From the library of Superior Sewing Machine & Supply LLC - www.supsew.com