

mitsubishi

三菱工業用ミシン部品カタログ

Industrial Sewing Machine Parts Catalog

Model LG2-3370

目次	INDEX	Page
① 本体関係	Arm bed & it's accessories	2
② 縫い機構 (I)	Sewing mechanism (I)	4
③ 縫い機構 (II)		
および下送り機構	Sewing mechanism (II) & feed rock lower shaft mechanism	6
④ 送り調節機構	Stitch length mechanism	8
⑤ 上送り調節機構	Top feed rock shaft mechanism	10
⑥ 押え機構	Presser foot mechanism	12
⑦ 上送り機構	Top feed mechanism	14
⑧ 糸切り機構	Knife actuating mechanism	16
⑨ タッチバック機構		
および検出器機構	Touch back mechanism & detector mechanism	18
⑩ 給油機構	Oil lubrication mechanism	20
⑪ 付属品 (I)	Accessories (I)	22
⑫ 付属品 (II)	Accessories (II)	24
⑬ ゲージ	Gauges	26

1 本体関係
 ARM BED & IT'S ACCESSORIES

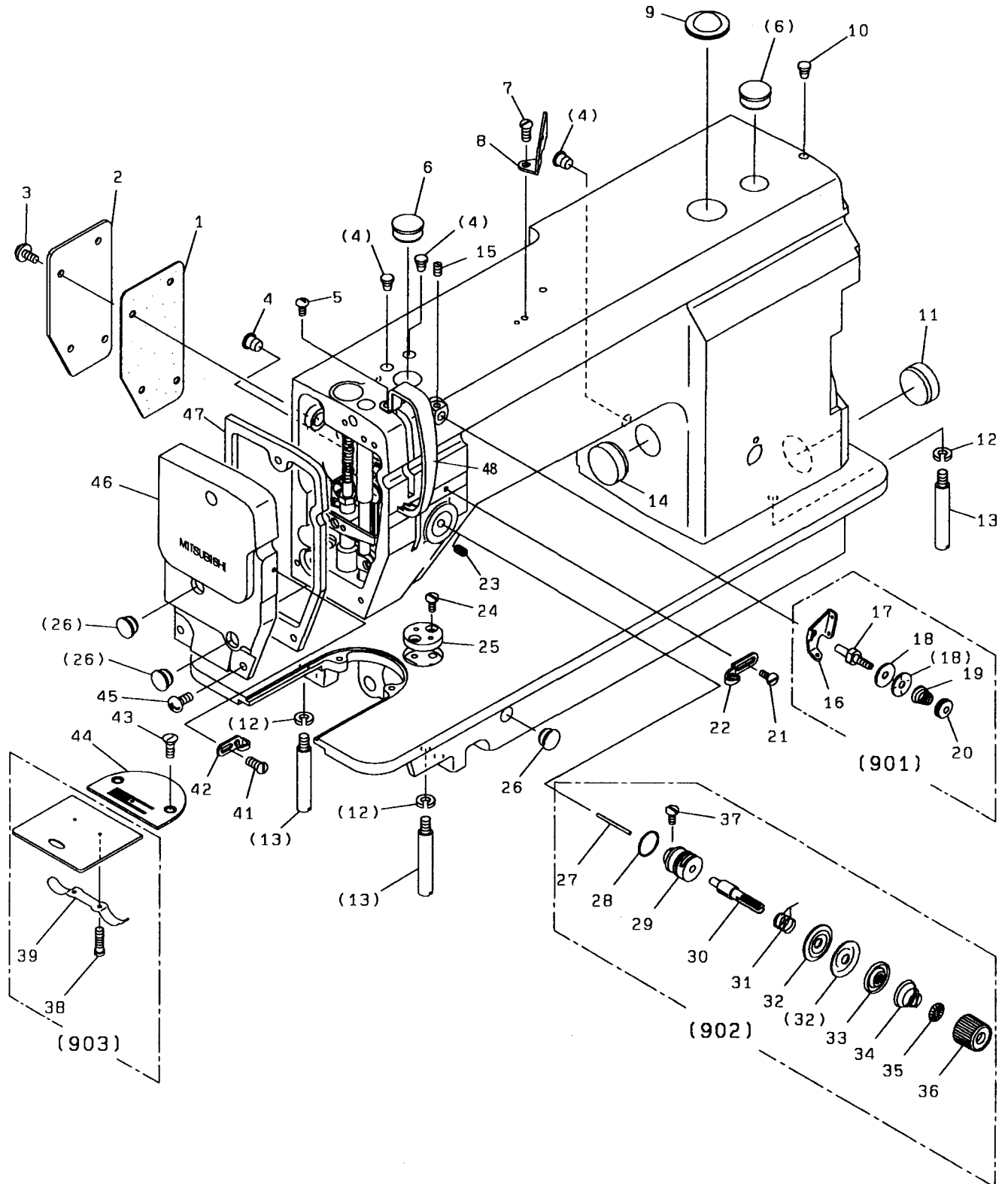

1 本体関係 ARM BED & IT'S ACCESSORIES

Fig. No.	部品コード Parts. No.	部 品 名	Description	使用個数 Amt. Req.
*	01 MH 00A0 691	ガasket	Arm side cover gasket	1
*	02 MH 00A0 880	ヨコブタ	Arm side cover	1
	03 M9 1109 004	PW付ブラマイネジ	11/64(40)X8	4
	04 M9 0883 080	ゴム栓	φ 8.8	5
	05 M9 1110 004	ブラマイネジ	11/64(40)X8	1
	06 M9 1910 080	ゴム栓	φ 19	2
	07 M9 1116 002	平ネジ	11/64(40)X8	1
	08 MF 36A1 180	アーム糸案内	(上)	1
	09 MF 20A0 135	油窓	Oil check window	1
	10 M9 0573 080	ゴム栓	φ 5.7	1
	11 M9 2701 080	ゴム栓	φ 27	1
	12 M9 0106 053	バネ座金	6	3
	13 MF 10A0 151	脚	Leg	3
	14 M9 2004 080	ゴム栓	φ 20	1
	15 M9 1108 001	止メネジ	11/64(40)X5.5	1
	16 MF 00A0 181	糸案内	Thread guide	1
	17 MF 90A0 553	糸案内調子棒	Pre-tension stud	1
	18 MF 10A1 553	調子皿	Thread tension disc	2
	19 MF 36A0 245	円錐バネ	Pre-tension spring	1
	20 M9 1101 046	ツマミナット	11/64(40)	1
	21 M9 0943 003	丸平ネジ	9/64(40)X6	1
	22 MF 80A0 181	アーム糸案内	(右)	1
	23 M9 1508 001	止メネジ	15/64(28)X6	1
	24 M9 1107 002	平ネジ	11/64(40)X5.5	2
*	25 MH 00A0 601	定規取付板	Cloth guide plate	1
	26 M9 1182 080	ゴム栓	φ 11.8	3
*	27 M9 0234 060	ピン	Thread releasing pin	1
	28 M9 1501 085	Oリング	S15	1
	29 MF 10A0 709	ブッシュ	Thread tension regulator bushing	1
	30 MF 10A0 553	調子棒	Thread tension stud	1
	31 MF 10A0 187	糸取りバネ	Thread take-up spring	1
	32 MF 10A0 555	調子皿	Thread tension disc	2
	33 MM 11A0 556	調子皿押エ	Thread tension reledsing disc	1
	34 MF 11D0 245	円錐バネ	Thread tension spring	1
	35 MT 60A0 802	回り止メ	Thumb nut revolution stopper	1
	36 M9 1605 045	調節ナット	1/4(40)	1
	37 M9 0901 002	平ネジ	9/64(40)X4	1
	38 M9 0604 002	平ネジ	3/32(56)X2.2	2
	39 MF 10A0 471	板バネ	Plate spring for slide plate	1
	41 M9 0909 003	丸平ネジ	9/64(40)X6	1
	42 MF 10A0 181	糸案内	(左)	1
	43 M9 1106 011	丸皿ネジ	11/64(40)X7	2
*	44 MH 00B1 101	針板	Throate plate	1
	45 M9 1111 004	ブラマイネジ	11/64(40)X10	3
*	46 MH 00A0 830	面板	Face plate	1
*	47 MH 00A1 691	ガスケット	Face plate gasket	1
	48 MF 01A0 584	天ピンカバー	Thread take-up cover	1
	901 MF 00E0 550	プリテンション	(組) Pre-tension assy.	1
*	902 MH 00E0 210	上糸調節器	(組) Thread tension regulator assy.	1
	903 MF 10E0 470	滑り板	(組) Slide plate assy.	1

*印は、LG2-3370 専用部品を示します。

2 縫い機構 (I)
SEWING MECHANISM (I)

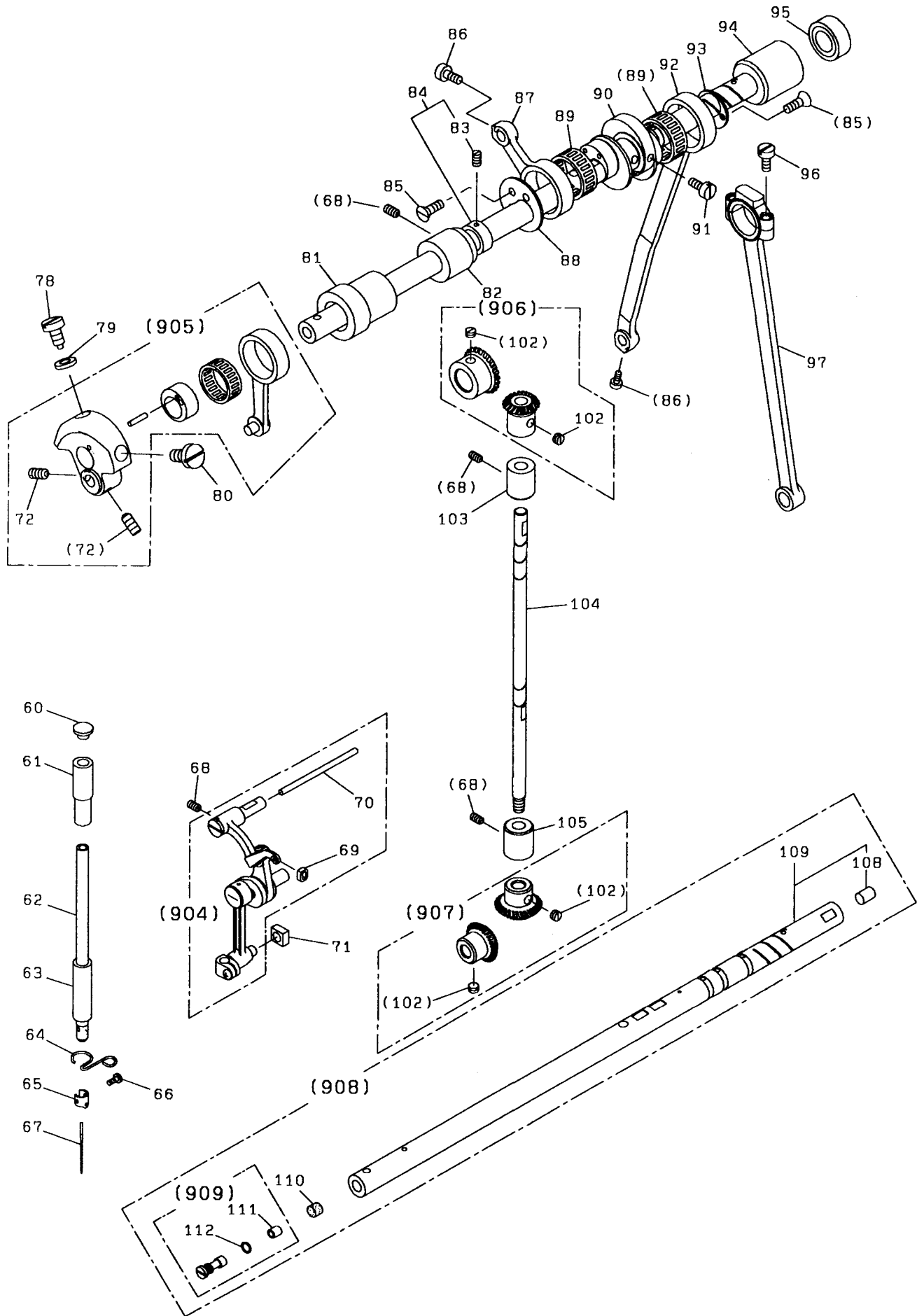

② 縫い機構 (I) SEWING MECHANISM (I)

Fig. No.	部品コード Parts. No.	部 品 名	Description	使用個数 Amt. Req.
	60 M9 0883 080	ゴム栓	φ8.8 Rubber plug φ8.8	1
	61 MF 70A0 663	針棒メタル	(上) Needle bar bushing(Upper)	1
*	62 MH 00A0 660	針棒	Needle bar	1
*	63 MH 00A0 664	針棒メタル	(下) Needle bar bushing(Lower)	1
*	64 MH 00A0 180	糸案内(針棒メタル下)	Thread guide	1
*	65 MH 00A1 180	糸案内(針棒)	Thread guide	1
	66 M9 0815 002	平ネジ	1/8(44)X4.5 Screw 1/8(44)X4.5	1
	67 MF 70A0 128	針	DBX1-2#14 Needle DBX1-2#14	1
	68 M9 1513 001	止メネジ	15/64(28)X9.5 Set screw 15/64(28)X9.5	4
	69 MF 01A0 417	油防キャップ	Oil shield cap	1
*	70 MF 01A0 740	フェルト	Felt	1
*	71 MH 00A0 325	角駒	Slide block	1
	72 M9 1606 001	止メネジ	1/4(40)X6 Set screw 1/4(40)X6	2
	78 M9 1802 006	棒先平ネジ	9/32(28)X14 Screw 9/32(28)X14	1
	79 M9 0700 085	Oリング	1AP7 O-ring 1AP7	1
	80 M9 1801 002	平ネジ	9/32(28)X13 Screw 9/32(28)X13	1
*	81 MH 00A0 232	上軸メタル	(左) Upper shaft bushing(Left)	1
	82 MF 05A0 234	上軸メタル	(中) Upper shaft bushing(Middle)	1
	83 M9 1602 001	止メネジ	1/4(40)X4 Set screw 1/4(40)X4	2
	84 MF 80A0 352	カラーネジ付	Thrust collar with screw	1
	85 M9 0902 011	丸皿ネジ	3/16(28)X13 Screw 3/16(28)X13	6
	86 M9 1521 002	平ネジ	11/64(40)X7 Screw 11/64(40)X7	2
*	87 MH 00A0 384	連接桿	Crank rod	1
*	88 M9 4007 052	座金	Thrust washer	1
	89 MN 35A0 628	ベアリング	Needle bearing	2
*	90 MH 00A0 492	偏心輪	Feed drive eccentric cam	1
	91 M9 1502 002	平ネジ	15/64(28)X12 Screw 15/64(28)X12	2
*	92 MH 00A1 384	連接桿	Crank rod	1
	93 M9 3008 050	座金	Thrust washer	1
	94 MF 01A0 233	上軸メタル	(右) Upper shaft bushing(Right)	1
	95 M9 1472 086	オイルシール	Oil seal	1
	96 M9 1203 002	平ネジ	3/16(28)X15 Screw 3/16(28)X15	2
*	97 MH 00A2 384	連接桿	Crank rod	1
	102 M9 1606 001	止メネジ	1/4(40)X7 Set screw 1/4(40)X7	8
	103 MG 75A0 521	堅軸メタル	(上) Vertical shaft bushing(Upper)	1
	104 MF 10A0 520	堅軸	Vertical shaft	1
	105 MF 70A0 522	堅軸メタル	(下) Vertical shaft bushing(Lower)	1
	108 M9 0740 080	ゴム栓	Rubber plug	1
*	109 MH 00A0 230	上軸	Upper shaft	1
	110 MF 01A1 740	フェルト	Felt	1
	111 MG 75A0 417	ゴム輪	Rubber bushing	1
	112 M9 0402 085	Oリング	S4 O-ring S4	1
*	904 MH 00E0 580	天秤・針棒クランプ	(組) Thread take-up lever assy.	1
*	905 MH 00E0 383	クランク	(組) Crank assy.	1
	906 MF 01E0 331	カサ歯車上	(組) Bevel gear upper assy.	1
	907 MF 01E0 332	カサ歯車下	(組) Bevel gear lower assy.	1
*	908 MH 00E0 230	上軸組立	Upper shaft assy.	1
	909 M9 7006 060	給油調節ピン	(組) Oil amount adjusting pin assy.	1

*印は、LG2-3370 専用部品を示します。

③ 縫い機構 (II) および下送り機構
 SEWING MECHANISM (II) & FEED ROCK LOWER SHAFT MECHANISM

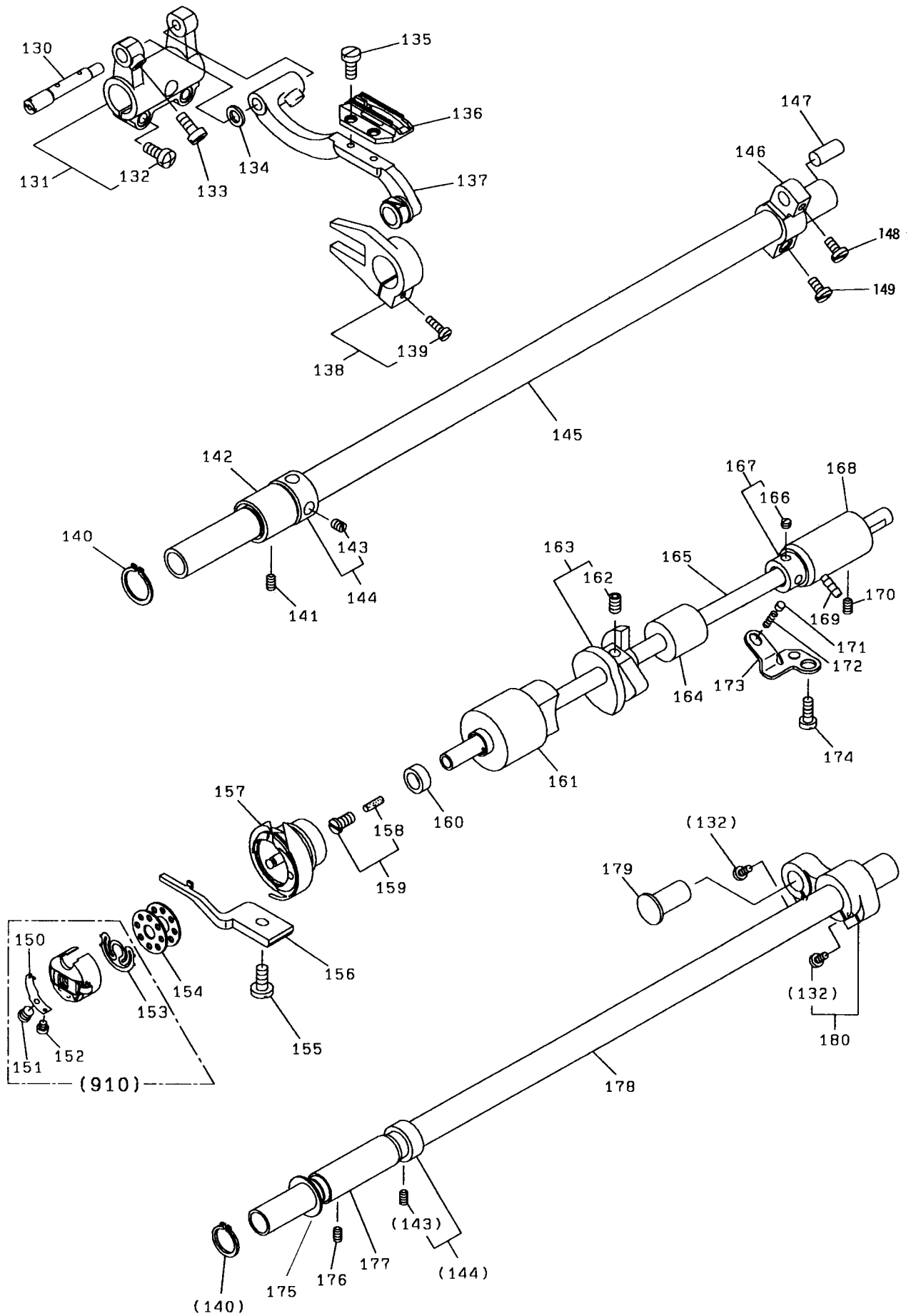

③ 縫い機構 (II) および下送り機構

SEWING MECHANISM (II) & FEED ROCK LOWER SHAFT MECHANISM

Fig. No.	部品コード Parts. No.	部 品 名	Description	使用個数 Amt. Req.
130	MF 90A0 283	偏心輪	Shaft for feed bar(Eccentric)	1
131	MF 90A0 278	水平送り腕左ネジ付	Feed rock shaft crank(Left)...	1
132	M9 1204 002	丸平ネジ	3/16(28)X12.....	4
133	M9 1106 004	ブラマイネジ	11/64(40)X8.....	1
134	M9 0619 050	座金	Washer	1
135	M9 0806 002	平ネジ	1/8(44)X6	2
* 136	MH 00B1 104	送り	Drop feed dog	1
137	MF 00E0 281	送り台	(組)	1
138	MF 01E0 276	上下送り二又ネジ付	Feed lifting rock shaft fork	1
139	M9 1112 002	平ネジ	11/64(40)X12	1
140	M9 0315 065	C形止メ輪軸用	15	2
141	M9 1502 001	止メネジ	15/64(28)X3.5	1
142	MF 00A0 286	水平送り軸メタル	(左)	1
143	M9 1602 001	止メネジ	1/4(40)X4	4
144	MF 80A0 352	カラーネジ付	Thrust collar with screw	2
145	MF 70A0 491	水平送り軸	Feed rock shaft	1
146	MF 00A0 279	水平送り腕	(右)	1
147	MF 00A0 454	水平送り腕軸	Feed rock shaft crank pin ...	1
148	M9 1521 002	平ネジ	11/64(40)X7.....	1
149	M9 1113 002	平ネジ	11/64(40)X15	1
150	MF 01A0 557	糸調子バネ	Bobbin thread tension spring	1
151	M9 7085 030	糸調子ネジ	3/32(100)X1.6	1
152	M9 7087 030	糸調子バネ止メネジ	1/16(80)X1.2	1
153	MF 01A0 245	空転防止バネ	Bobbin tension spring	1
154	ME 00A0 123	ボビン	Bobbin	1
155	M9 1118 002	平ネジ	11/64(40)X10	1
156	MF 10A0 229	内釜止メ	Hook positioner	1
157	MF 00A0 120	釜組	Rotary hook assy.	1
158	MF 05A0 740	フィルター	Oil felt for lower shaft	1
159	M9 1259 030	特殊ネジ	(組)3/16(32)X9.....	1
160	M9 0800 086	オイルシール	8X12X3	1
161	MF 00A0 451	下軸メタル	(左)	1
162	M9 1602 020	六角穴付止メネジ	1/4(40)X10	2
163	MF 01E0 350	糸切りカムネジ付	Thread trimmer cam with screw	1
164	MF 00A0 453	下軸メタル	(中)	1
165	MF 00A0 450	下軸	Lower shaft	1
166	M9 1106 001	止メネジ	11/64(40)X3.7	2
167	MF 01E0 352	カラーネジ付	Thrust collar with screw	1
168	MF 00A0 452	下軸メタル	(右)	1
169	MF 80A0 688	パイプ	Oil pipe for lower shaft bushing	1
170	M9 1513 001	止メネジ	15/64(28)X9.5.....	1
171	MF 00A0 753	プランジャ	Plunger	1
172	MF 00A0 572	ツルマキバネ	Coil spring.....	1
173	MF 80A0 154	案内板	Guide plate.....	1
174	M9 1515 002	平ネジ	15/64(28)X10	1
175	M9 1502 050	スラスト座金	Thrust washer.....	1
176	M9 1513 001	止メネジ	15/64(28)X9.5.....	1
177	MF 70A0 286	上下送り軸メタル	(左)	1
178	MF 70A0 460	上下送り軸	Feed lifting rock shaft	1
179	M9 0904 060	ツバ付軸	Pin	1
* 180	MH 00E0 277	上下送り腕右ネジ付	Feed lifting rock shaft crank(Right)	1
910	MF 40E0 125	ボビンケース	(組)	1

*印は、LG2-3370 専用部品を示します。

4 送り調節機構
STITCH LENGTH MECHANISM

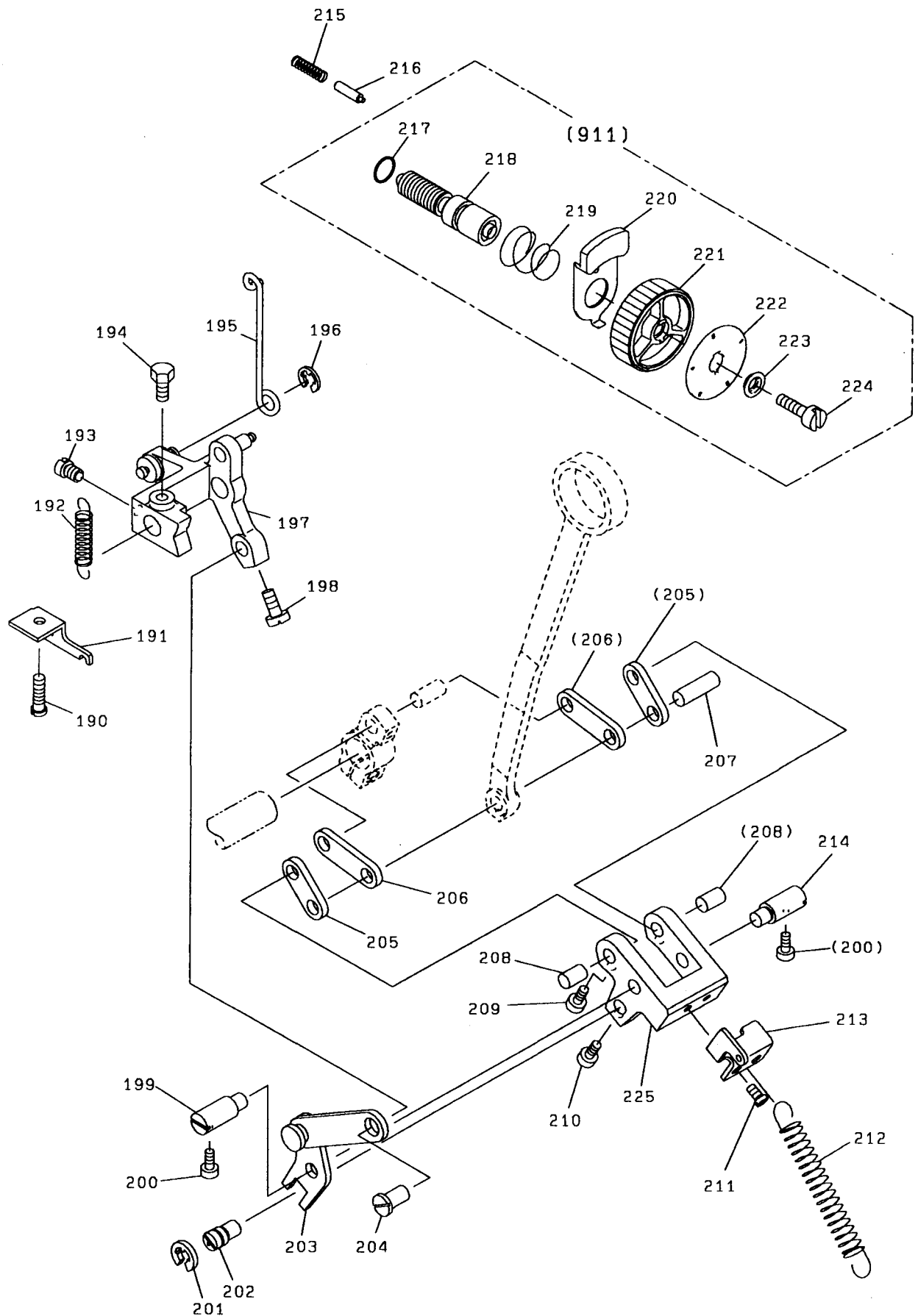

4 送り調節機構 STITCH LENGTH MECHANISM

Fig. No.	部品コード Parts. No.	部 品 名	Description	使用個数 Amt. Req.
	190 M9 1106 004	ブラマイネジ	11/64(40)X8..... Screw 11/64(40)X8.....	1
*	191 MH 00A1 708	バネ掛ケ Spring holder.....	1
*	192 MH 00A1 572	ツルマキバネ Coil spring.....	1
	193 M9 1505 007	棒先丸平ネジ	15/64(28)X12 Screw 15/64(28)X12	1
	194 M9 1509 022	ボルト	15/64(28)X12.5 ... Bolt 15/64(28)X12.5	1
*	195 MH 00A0 738	返し引棒 Reverse pull bar	1
	196 M9 0705 065	E形止メ輪	5 Retaining ring E-type 5... ..	1
*	197 MH 00E0 291	送り調節カム	(組)..... Feed adjusting cam.....	1
	198 M9 1521 002	平ネジ	11/64(40)X7..... Screw 11/64(40)X7.....	1
*	199 MH 00A0 530	段付軸 Feed regulator stud	1
	200 M9 1112 002	平ネジ	11/64(40)X12 Screw 11/64(40)X12	2
	201 M9 0706 065	E形止メ輪	6 Retaining ring E-type 6	1
*	202 MH 00A0 761	偏心軸 Eccentric stud	1
*	203 MH 00E0 953	送り連結板	(組)..... Feed regulator link assy. ...	1
*	204 MH 00A1 530	段付軸 Pin	1
	205 MF 00A2 910	リンク Link.....	2
	206 MF 00A3 910	リンク Link.....	2
	207 MF 00A1 454	軸 Link stud	1
	208 MF 00A2 454	軸 Link stud	2
	209 M9 1102 002	平ネジ	11/64(40)X8.5..... Screw 11/64(40)X8.5	2
	210 M9 1521 002	平ネジ	11/64(40)X7..... Screw 11/64(40)X7.....	1
	211 M9 1109 002	平ネジ	11/64(40)X7..... Screw 11/64(40)X7.....	2
*	212 MH 00A2 572	ツルマキバネ Coil spring.....	1
*	213 MH 00A0 708	掛ケ金 Spring holder.....	1
*	214 MH 00A3 572	段付軸 Feed regulator shaft.....	1
	215 MF 05A0 572	ツルマキバネ Coil spring.....	1
	216 MF 00A0 852	位置決メピン Stopper pin.....	1
	217 M9 1000 085	Oリング	1AP10A..... O-ring 1AP10A.....	1
	218 MF 85A0 640	送り調節ネジ Screw bar.....	1
	219 MF 02A0 245	円錐バネ Coil spring.....	1
	220 MF 00A0 950	レバー Stopper pin veleasing lever... ..	1
	221 MF 01A0 631	ダイヤル Dial	1
	222 MN 82A0 841	目盛板 Stitch length indicating plate	1
	223 MF 00A0 257	押工金 Bushing	1
	224 M9 1215 002	平ネジ	3/16(28)X12..... Screw 3/16(28)X12	1
*	225 MH 00A0 289	送り調節腕 Stitch length adjusting crank	1
*	911 MH 00E0 640	送り調節ネジ	(組)..... Screw bar assy.	1

*印は、LG2-3370 専用部品を示します。

5 上送り調節機構
TOP FEED ROCK SHAFT MECHANISM

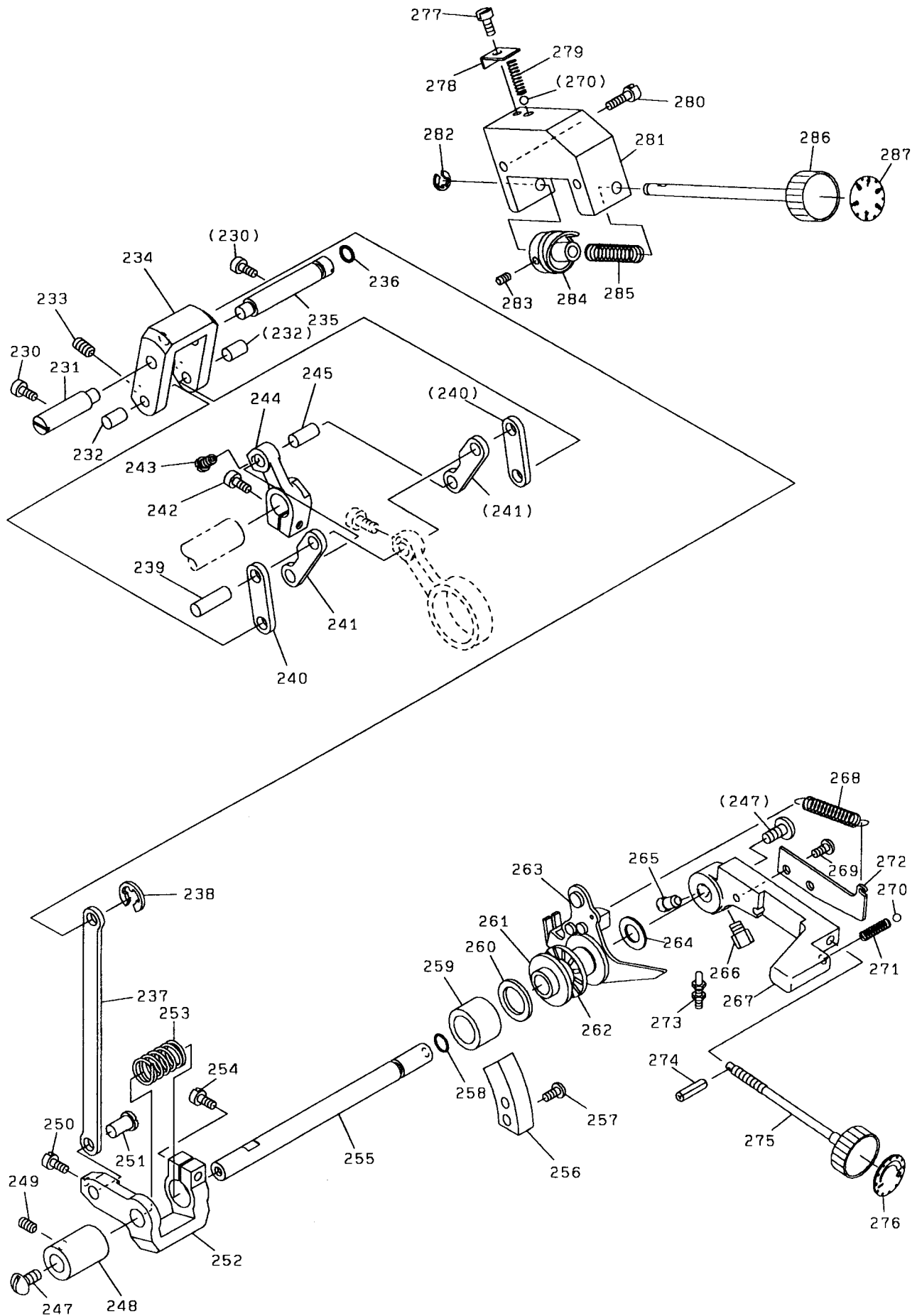

⑤ 上送り調節機構 TOP FEED ROCK SHAFT MECHANISM

Fig. No.	部品コード Parts No.	部 品 名	Description	使用個数 Amt. Req.	
	230 M9 1112 002	平ネジ	11/64(40)X12	Screw 11/64(40)X12	2
*	231 MH 00A3 530	段付軸		Feed regulator stud	1
	232 MF 00A2 454	軸		Link stud	2
	233 M9 1001 020	六角穴付止メネジ	11/64(40)X5	Socket screw 11/64(40)X5	2
*	234 MH 00E1 289	上送り調節腕	(組)	Top stitch length adjusting crank assy.	1
*	235 MH 00A4 530	段付軸		Feed regulator stud	1
	236 M9 0700 085	Oリング	1AP7	O-ring 1AP7	1
*	237 MH 00A0 910	リンク		Link	1
	238 M9 0705 065	E形止メ輪	5	Retaining ring E-type 5	1
	239 MF 00A1 454	軸		Link stud	1
	240 MF 00A3 910	リンク		Link	2
	241 MF 02A0 910	リンク		Link	2
	242 M9 1203 002	平ネジ	3/16(28)X15	Screw 3/16(28)X15	1
	243 M9 1521 002	平ネジ	11/64(40)X7	Screw 11/64(40)X7	1
*	244 MH 00A0 465	上水平送り腕		Top feed rock shaft crank	1
	245 MF 00A0 454	軸		feed rock shaft crank pin	1
	247 M9 1207 003	丸平ネジ	3/16(28)X6.5	Screw 3/16(28)X6.5	2
*	248 MH 00A0 833	返し縫い軸メタル		Feed reverse shaft bushing	1
	249 M9 1108 001	止メネジ	11/64(40)X5.5	Screw 11/64(40)X5.5	1
	250 M9 1102 002	平ネジ	11/64(40)X8.5	Screw 11/64(40)X8.5	1
*	251 MH 00A1 530	段付軸		Pin	1
*	252 MH 00A0 257	上送り腕		Top feed arm	1
*	253 MH 00A1 729	捻りバネ		coil spring	1
	254 M9 1203 002	平ネジ	3/16(28)X15	Screw 3/16(28)X15	1
*	255 MH 00A0 320	返し縫い軸		Feed reverse shaft	1
*	256 MH 00A0 841	上送り目盛板		Top feeding scale plate	1
	257 M9 1107 002	平ネジ	11/64(40)X5.5	Screw 11/64(40)X5.5	2
	258 M9 0600 085	Oリング	1AP6	O-ring 1AP6	1
*	259 MH 00A0 628	ベアリング		Needle bearing	1
*	260 M9 1501 086	オイルシール	15X22X3	Oil seal 15X22X3	1
*	261 M9 8013 050	座金		Thrust washer	1
*	262 M9 4007 070	スラストニードルベアリング		Thrust bearing	1
*	263 MH 00E0 750	上送りブッシュ	(組)	Top feed lever	1
*	264 M9 1015 050	座金		Washer	1
	265 M9 1505 007	棒先丸平ネジ	15/64(28)X12	Screw 15/64(28)X12	1
	266 M9 1509 022	ボルト	15/64(28)X12.5	Bolt 15/64(28)X12.5	1
*	267 MH 00A0 632	縫目加減レバー		Stitch adjusting lever	1
*	268 MH 00A3 572	ツルマキバネ		Coil spring	1
	269 M9 1110 002	平ネジ	11/64(40)X8	Screw 11/64(40)X8	2
*	270 M9 8012 070	鋼球	5	Ball 5	2
*	271 MH 00A4 572	ツルマキバネ		Spring	1
*	272 MH 00A3 708	バネ掛け		Spring holder	1
*	273 MH 00E0 477	ストッパー	(組)	Stopper assy.	1
*	274 M9 0104 064	スプリングピン	φ1.6X6	Spring pin φ1.6X6	1
*	275 MH 00A0 631	上送りダイヤル		Top feeding dial	1
*	276 MH 00A0 645	ネーマ		Top indicating plate	1
	277 M9 1109 002	平ネジ	11/64(40)X7	Screw 11/64(40)X7	1
*	278 MH 00A0 702	バネ受け板		Spring holder	1
*	279 MH 00A5 572	ツルマキバネ		Coil spring	1
	280 M9 1126 002	平ネジ	11/64(40)X27	Screw 11/64(40)X27	2
*	281 MH 00A0 477	ストッパーダイ		Ruffling stopper base	1
	282 M9 0504 065	E形止メ輪	4	Retaining ring E-type 4	1
*	283 M9 1109 001	止メネジ	11/64(40)X6	Set screw 11/64(40)X6	2
*	284 MH 00A0 350	ストッパーカム		Ruffling stopper cam	1
*	285 MH 00A6 572	ツルマキバネ		Coil spring	1
*	286 MH 00A1 631	ストッパーダイヤル		Ruffling stopper dial	1
*	287 MH 00A1 645	ネーマ		Ruffling indicating plate	1

*印は、LG2-3370 専用部品を示します。

6 押え機構
PRESSER FOOT MECHANISM

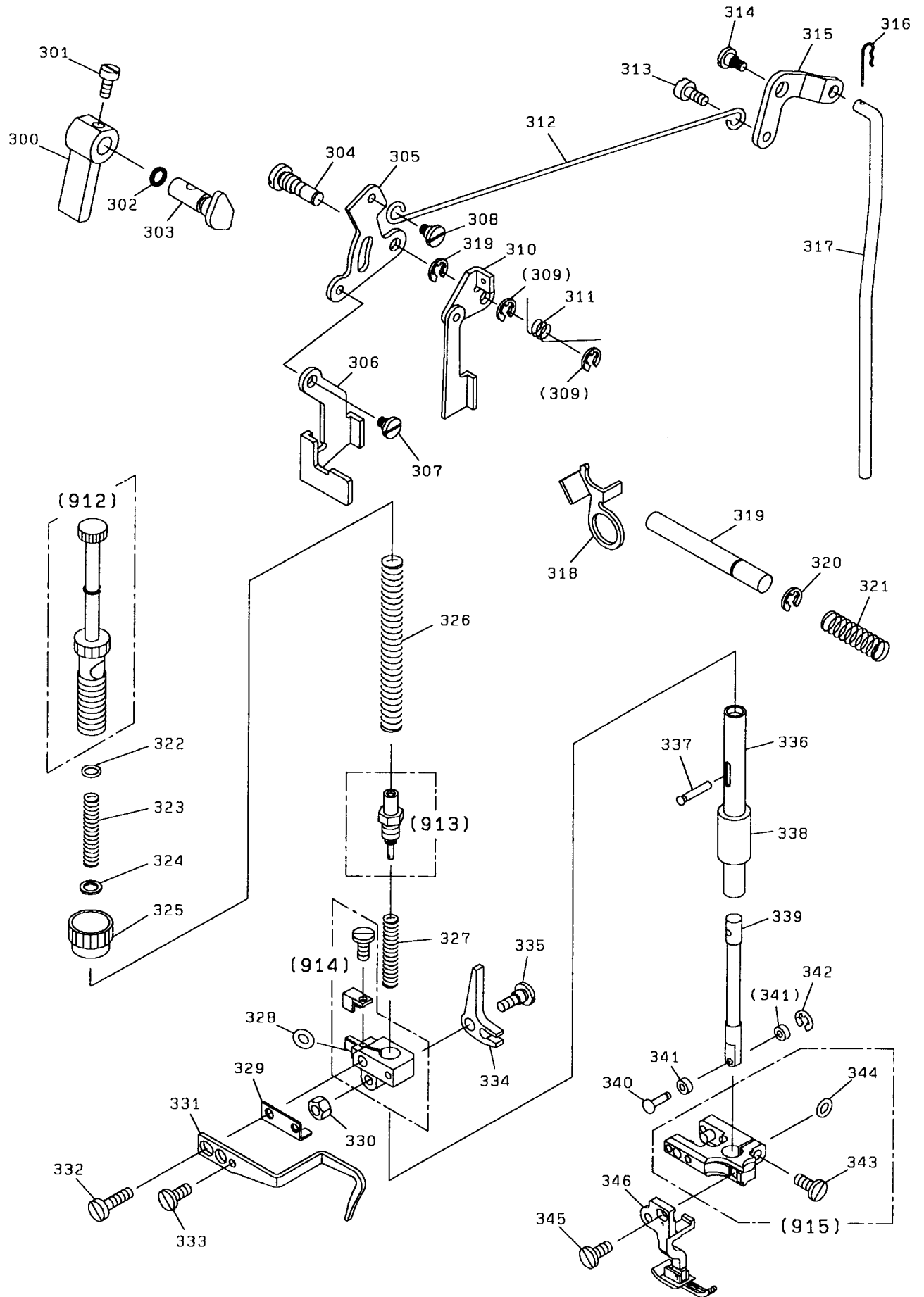

6 押え機構 PRESSER FOOT MECHANISM

Fig. No.	部品コード Parts. No.	部品名	Description	使用個数 Amt. Req.
* 300	MH 00A0 252	押え上ゲレバー	Presser foot lifter lever	1
301	M9 1111 003	丸平ネジ	11/64(40)X10 Screw	1
* 302	M9 0600 085	Oリング	1AP5 O-ring	1
* 303	MH 00A0 253	押え上ゲカム	Lifter cam	1
* 304	M9 2002 015	段付平ネジ	5/16(24)X8 Stud screw	1
* 305	MH 00A1 252	押え上ゲレバー (左)	Presser up lever (Left)	1
* 306	MH 00A0 720	引き上げ板	Pullup plate	1
* 307	M9 1114 015	段付平ネジ	11/64(40)X2.6 Shoulder screw	1
* 308	M9 1113 015	段付平ネジ	11/64(40)X3.5 Shoulder screw	1
309	M9 0705 065	E形止メ輪	5 Retaining ring E-type	3
* 310	MH 00E1 720	糸緩メ引き上げ板 (組)	Tension release link assy.	1
* 311	MH 00A0 700	糸緩メレバーバネ	Spring	1
312	MF 70A0 738	引棒	Knee lifter rod	1
313	M9 1219 015	段付平ネジ	3/16(28)X3.5 Stud screw	1
314	M9 1503 031	段付ボルト	15/64(28)X6.5 Stud bolt	1
* 315	MH 00A2 252	押え上ゲレバー (右)	Knee lifter lever (Right)	1
* 316	M9 0601 065	スナップピン	Snap pin 6	1
* 317	MH 00A0 511	操作棒	Knee lifter connecting rod	1
* 318	MH 00A0 221	糸緩メ板	Tension release plate	1
* 319	M9 0525 060	糸緩メピン	Tension release pin	1
320	M9 0707 065	E形止メ輪	3 Retaining ring E-type	1
* 321	MH 00A0 223	糸緩メバネ	Tension release pin spring	1
* 322	M9 0624 050	案内棒バネ受け座金	Washer	1
* 323	MH 00A1 700	案内棒バネ	Top feed adjusting knob spring	1
* 324	M9 0625 050	押えバネ受け座金	Washer	1
325	M9 3202 047	ツマミナット	1/2(28) Thumb nut	1
* 326	MH 00A0 259	押えバネ	Presser spring	1
* 327	MH 00A2 700	上送りバネ	Top feed spring	1
* 328	M9 0513 050	座金	5 Washer	1
* 329	MH 00A0 161	当て板	Bracket plate	1
330	M9 1252 045	ナット	3/16(32) Nut	1
* 331	MH 00A0 216	上糸案内	Upper thread guide	1
332	M9 1113 002	平ネジ	11/64(40)X15 Screw	1
333	M9 0922 002	平ネジ	9/64(40)X6 Screw	1
* 334	MH 00A0 763	ベルクランク	Bellcrank	1
* 335	M9 1265 015	段付平ネジ	3/16(32)X10 Stud screw	1
* 336	MH 00A0 262	押え棒	Presser bar	1
* 337	M9 0326 060	上下ピン	Top feed lifting pin	1
* 338	MH 00A0 267	押え棒メタル	Presser bar bushing	1
* 339	MH 00A0 784	上下棒	Top feed lifting bar	1
* 340	MH 00A0 412	上下棒コロ軸	Roller pin	1
* 341	MH 00A0 411	上下棒コロ	Roller	2
* 342	M9 9002 065	クリセント形止メ輪	Snap ring	1
343	M9 1206 003	丸平ネジ	3/16(28)X10 Screw	1
* 344	M9 5014 050	座金	5 Washer	1
345	M9 1204 003	丸平ネジ	3/16(28)X12 Screw	1
* 346	MH 00B1 105	押え	(組) Presser foot	1
* 912	MH 00E0 261	押え調節ネジ	(組) Presser adjusting screw assy.	1
* 913	MH 00E0 366	押え棒キャップネジ	(組) Cap nut assy.	1
* 914	MH 00E0 265	押え棒抱きガイド	(組) Presser bar guide bracket assy.	1
* 915	MH 00E0 263	押え棒台	(組) Presser bar base assy.	1

*印は、LG2-3370 専用部品を示します。

7 上送り機構
TOP FEED MECHANISM

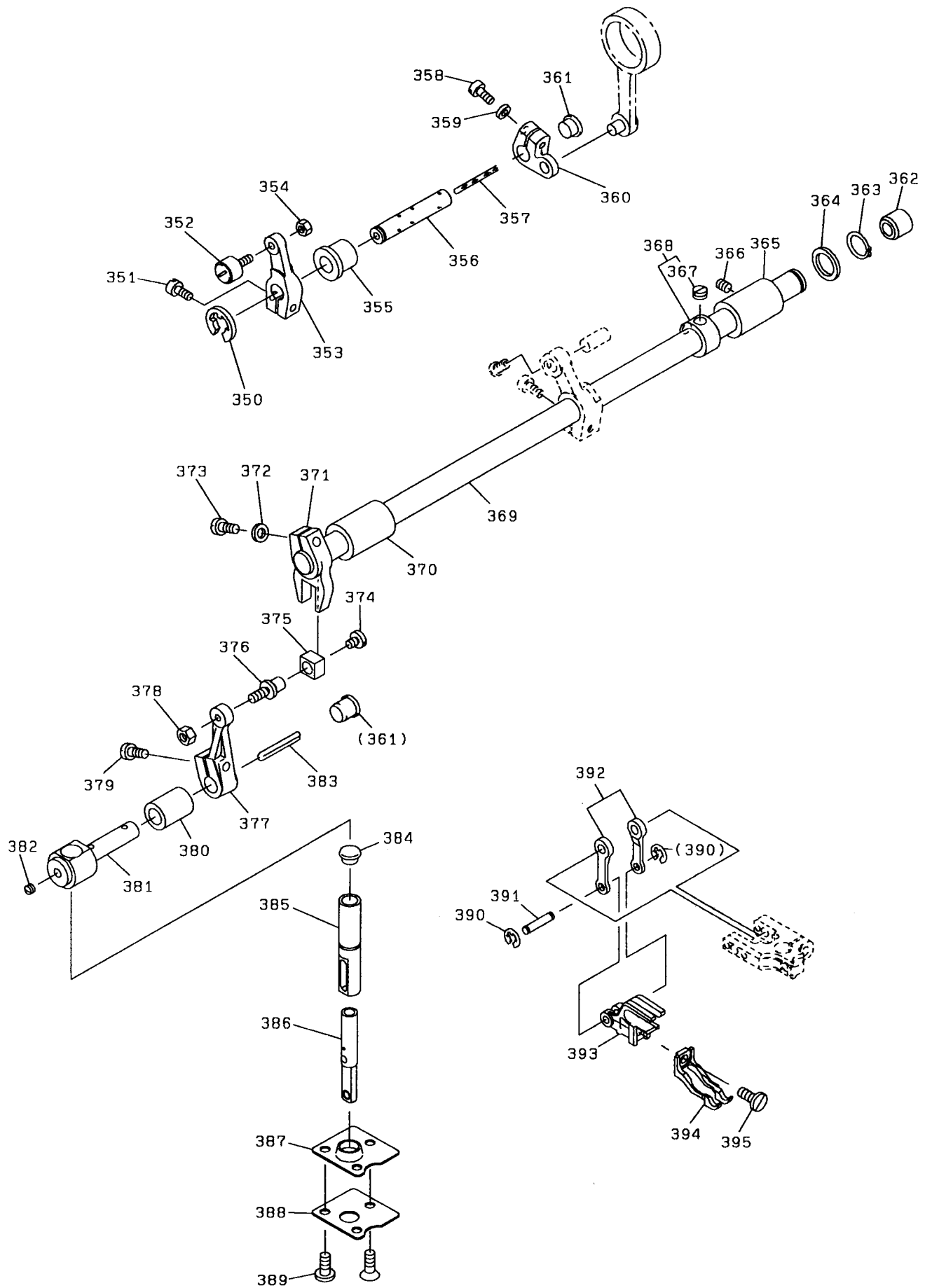

7 上送り機構
TOP FEED MECHANISM

Fig. No.	部品コード Parts. No.	部 品 名	Description	使用個数 Amt. Req.
* 350	M9 0708 065	E形止メ輪	7 Retaining ring E-type 7.....	1
351	M9 1204 003	丸平ネジ	3/16(28)X12..... Screw 3/16(28)X12	1
* 352	M9 7001 070	カムフォロアー Cam follower	1
* 353	MH 00A0 463	上送り上下腕	(前)..... Top feed vertical arm (Front)...	1
* 354	M9 1003 045	ナット	M4 Nut M4	1
* 355	MH 00A0 285	上送り上下軸メタル Top feed vertical shaft bushing ...	1
* 356	MH 00A0 460	上部上下軸 Top feed vertical shaft	1
357	MN 70E0 148	綿芯 Oil wick	1
358	M9 1206 003	丸平ネジ	3/16(28)X10..... Screw 3/16(28)X10	1
359	M9 0501 050	座金 Washer	1
* 360	MH 00A0 462	上送り上下腕	(後)..... Top feed vertical arm (Year) ...	1
* 361	M9 1005 080	ゴム栓	φ10.5..... Rubber plug φ10.5	2
362	M9 2005 080	ゴム栓	φ21.5..... Rubber plug φ21.5	1
363	M9 0312 065	C形止メ輪用	12 Retaining ring C-type 12.....	1
364	M9 1402 050	座金 Washer	1
* 365	MH 00A0 287	上送り水平軸メタル	(右)..... Upper horizontal bushing (Right) ...	1
366	M9 1111 001	止メネジ	11/64(40)X10..... Set screw 11/64(40)X10.....	1
367	M9 1601 001	止メネジ	1/4(40)X3..... Set screw 1/4(40)X3	2
368	MH 00A1 352	カラーネジ付 Thrust collar with screw	1
* 369	MH 00A0 491	上送り水平軸 Upper horizontal rocker shaft ...	1
* 370	MH 00A0 286	上送り水平軸メタル	(左)..... Upper horizontal bushing (Left) ...	1
* 371	MH 00A0 744	上水平二又 Upper horizontal forked arm...	1
372	M9 0501 050	座金 Washer	1
373	M9 1204 003	丸平ネジ	3/16(28)X12..... Screw 3/16(28)X12	1
* 374	M9 1134 002	平ネジ	11/64(40)X5.5..... Screw 11/64(40)X5.5	1
* 375	MH 00A1 325	角駒 Square block.....	1
* 376	MH 00A1 412	コ口軸 Square block stud.....	1
* 377	MH 00A0 228	上水平腕 Upper rocker crank.....	1
378	M9 1202 045	ナット	3/16(28)..... Nut 3/16(28).....	1
379	M9 1203 002	平ネジ	3/16(28)X15..... Screw 3/16(28)X15	1
* 380	MH 00A1 833	上水平軸メタル Upper rocker shaft bushing...	1
* 381	MH 00A1 491	上水平軸 Upper rocker shaft	1
382	M9 1503 001	止メネジ Set screw	1
383	MF 10E2 148	アブラヒモ Oil wick.....	1
384	M9 0883 080	ゴム栓	φ8.8 Rubber plug φ8.8	1
* 385	MH 00A2 833	水平棒メタル Top feed bar bushing	1
* 386	MH 00E1 784	水平棒	(組)..... Top feed bar.....	1
* 387	MH 00A2 691	パッキン Gasket	1
* 388	MH 00A0 257	パッキン押エ Gasket plate.....	1
* 389	M9 1103 010	皿ネジ	11/64(40)X8.2..... Screw 11/64(40)X8.2.....	3
* 390	M9 9003 065	軸用CE形リング	4 Retaining ring CE type 4.....	2
* 391	MH 00A0 454	軸 Pin	1
* 392	MH 00A1 910	リンク	(組)..... Link assy.....	1
* 393	MH 00A0 281	上送り台 Top feed dog base	1
* 394	MH 00B1 294	上送り Top feed dog	1
395	M9 1116 002	平ネジ	11/64(40)X8..... Screw 11/64(40)X8	1

*印は、LG2-3370 専用部品を示します。

8 糸切り機構
KNIFE ACTUATING MECHANISM

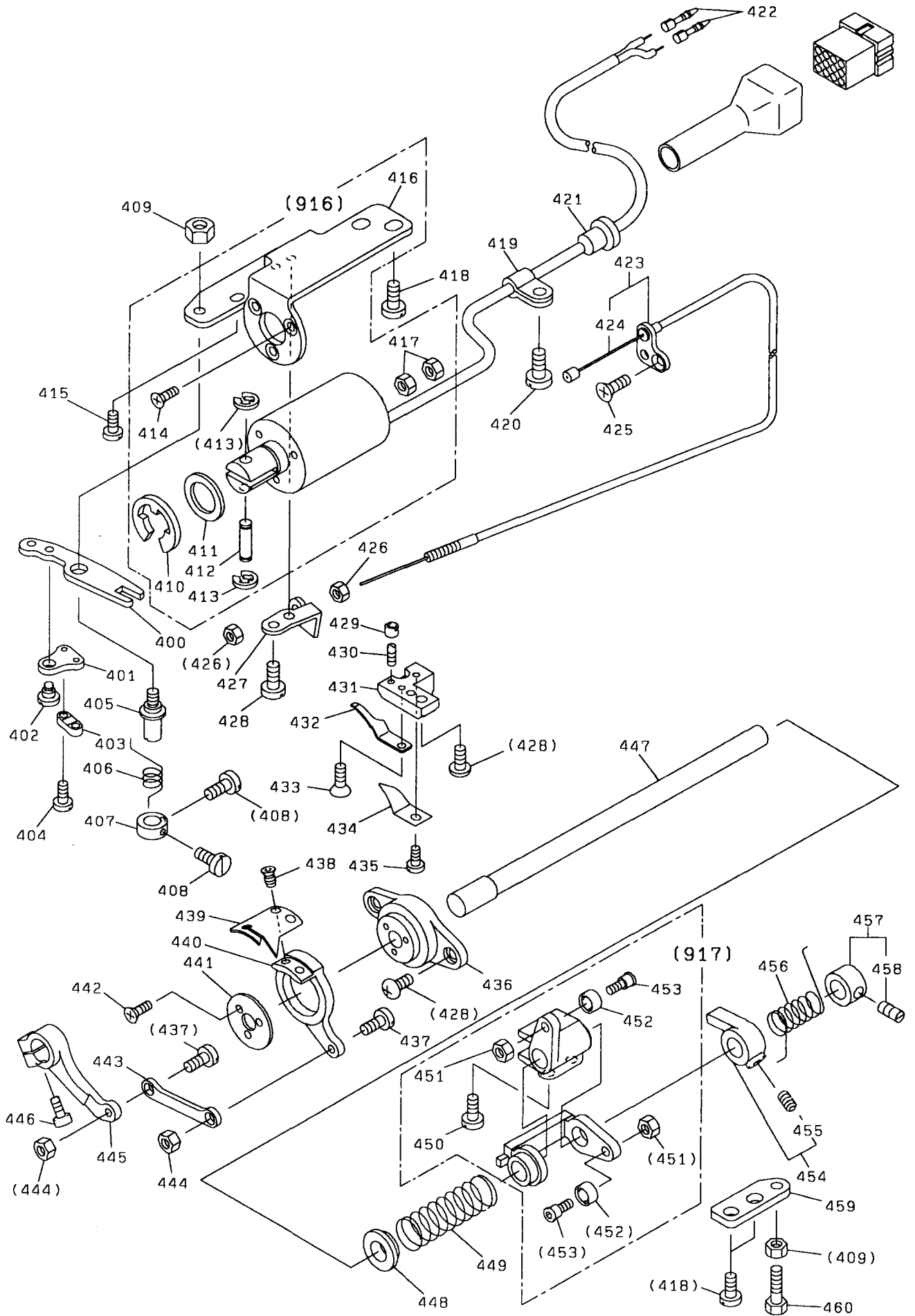

⑧ 糸切り機構 KNIFE ACTUATING MECHANISM

Fig. No.	部品コード Parts. No.	部 品 名	Description	使用個数 Amt. Req.
* 400	MH 00A0 391	駆動板	Thread trimmer driving lever	1
401	MF 90A0 361	掛ケ金	Flexible wire holder	1
* 402	M9 1141 015	段付平ネジ	11/64(40)X3.3 Stud screw	1
403	MF 36A0 750	ブッシュ	Flexible wire presser	1
404	M9 0802 002	平ネジ	1/8(44)X7 Screw	2
405	M9 7082 030	特殊ネジ	15/64(28)X7.5 Stud screw	1
406	MF 00A1 729	ヒネリバネ	Trimming lever spring	1
407	MF 00A1 352	カラー	Spring support collar	1
408	M9 0903 002	平ネジ	9/64(40)X6.5 Screw	2
409	M9 1502 045	ナット	15/64(28) Nut	2
410	M9 0703 065	E形止メ輪	12 Retaining ring E-type	1
411	MF 01A0 397	クッション	Cushion	1
412	M9 0516 063	ピン	Pin	1
413	M9 0504 065	E形止メ輪	4 Retaining ring E-type	2
414	M9 4008 037	P皿ネジ	M4X6 Screw	3
415	M9 1118 002	平ネジ	11/64(40)X10 Screw	1
416	MF 00A1 509	ソレノイド取付板	Solenoid bracket	1
417	M9 2074 075	止メナット	M5 Nut	2
418	M9 1510 002	平ネジ	15/64(28)X12 Screw	4
419	M9 4003 099	コードホルダー	Cord holder	1
420	M9 1109 004	PW付ブラマイネジ	11/64(40)X8 Screw	1
421	M9 1003 080	ゴムブッシュ	Rubber bushing	1
422	M9 3003 099	ピンターミナル	(オス) Termini pin(Male)	2
* 423	MH 00E0 746	フレキシブルワイヤ	(組) Flexible wire assy.	1
424	MF 00A0 746	フレキシブルワイヤ	Flexible wire	1
425	M9 1103 011	丸皿ネジ	11/64(40)X7 Screw	1
426	M9 1373 045	ナット	M5 Nut	2
427	MG 52E0 780	ホルダー	Holder	1
428	M9 1106 004	ブラマイネジ	11/64(40)X8 Screw	5
429	M9 1110 045	ナット	11/64(40) Nut	1
430	M9 0913 001	止メネジ	9/64(40)X8.5 Set screw	1
431	MF 00A1 603	取付台	Bracket for fixed blade	1
432	MF 00A0 838	固定メス	Fixed blade	1
433	M9 1102 010	皿ネジ	11/64(40)X9 Screw	1
434	MF 00A0 180	糸案内	Thread finger	1
435	M9 0921 002	平ネジ	9/64(40)X8 Screw	1
436	MF 00A1 527	台座	Knife holding bracket saddle	1
437	M9 1111 015	段付平ネジ	11/64(40)X6.2 Stud screw	2
438	M9 1151 010	皿ネジ	11/64(40)X7 Screw	2
439	MF 00A0 834	メス	(左) Movable knife(Left)	1
440	MF 00A0 836	メス台	(左) Knife base(Left)	1
441	M9 4006 052	座金	Thrust washer	1
442	M9 0803 010	皿ネジ	1/8(44)X6 Screw	3
443	MF 00A8 910	リンク	Link	1
444	M9 1107 045	ナット	11/64(40) Nut	2
445	MF 00A1 392	駆動腕	Knife driving crank	1
446	M9 1117 002	丸平ネジ	11/64(40)X13 Screw	1
447	MF 00A5 454	メス揺動軸	Knife driving shaft	1
448	MF 00A0 750	ブッシュ	Bushing	1
449	MF 00A9 572	ツルマキバネ	Coil spring	1
450	M9 1516 002	平ネジ	15/64(28)X8.5 Screw	2
451	M9 1201 045	ナット	3/16(28) Nut	2
452	MF 00A0 411	コロ	Roller	2
453	MF 00A0 412	コロ軸	Roller stud	2
454	MG 52A0 477	ストッパーネジ付	Stopper screw	1
455	M9 1606 001	止メネジ	1/4(40)X7 Set screw	1
456	MF 00A0 729	ヒネリバネ	Coil spring	1
457	MF 01E1 352	カラーネジ付	Collar with screw	1
458	M9 1602 001	止メネジ	1/4(40)X4 Set screw	1
459	MF 00A1 477	ストッパー板	Lever stopper plate	1
460	M9 1512 022	ボルト	15/64(28)X23 Bolt	1
916	MF 00E3 519	糸切りソレノイド	(組) Thread trimming solenoid	1
917	MF 01E0 351	カム追従腕	(組) Cam follower crank assy.	1

*印は、LG2-3370 専用部品を示します。

9 タッチバック機構および検出器機構
TOUCH BACK MECHANISM & DETECTOR MECHANISM

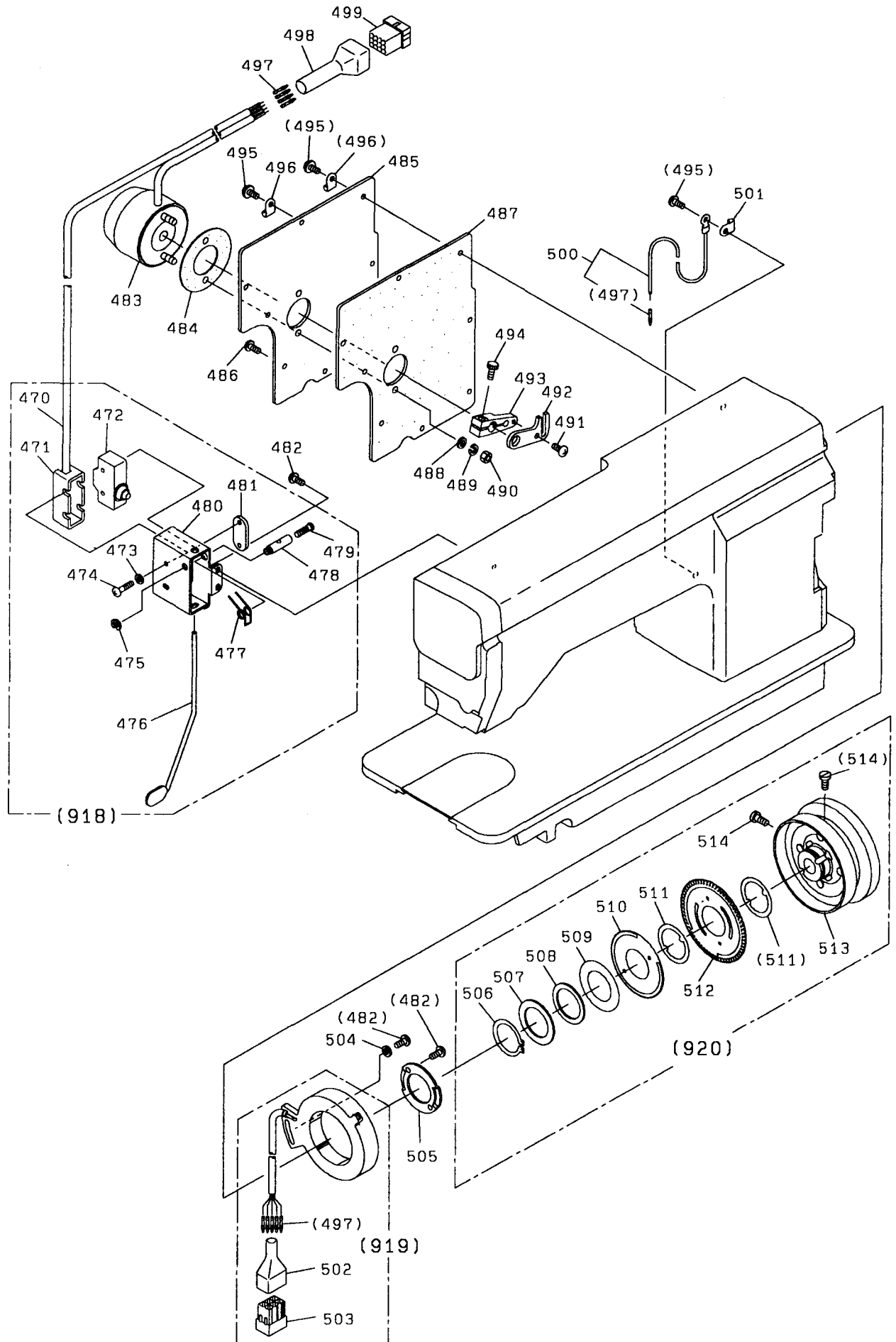

⑨ タッチバック機構および検出器機構

TOUCH BACK MECHANISM & DETECTOR MECHANISM

Fig. No.	部品コード Parts. No.	部 品 名	Description	使用個数 Amt. Req.
470	M9 7104 099	コード	(組)..... Cable assy.	1
471	MF 40A4 339	端子保護カバー	(AA8000)..... Switch cover (AA8000).....	1
472	M9 0204 099	スイッチ	(AM1306)..... Switch (AM1306).....	1
473	M9 0450 050	座金	4..... Washer 4.....	2
474	M9 0412 037	Pナベネジ	M4X30..... Screw M4X30.....	2
475	M9 0505 065	Eガタ止メ輪	5..... E-ring 5.....	1
* 476	MH 00A3 950	レバークミタテ Touch lever	1
477	MF 40A0 729	ヒネリバネ Touch lever spring.....	1
478	MF 40A1 530	段付軸 Stopped shaft	1
479	M9 1117 002	丸平ネジ	11/64(40)X11.5... Screw 11/64(40)X11.5.....	1
480	MN 35A0 339	カバー Switch cover.....	1
481	MF 40A3 601	取付板 Set plate	1
482	M9 1106 004	ブラマイネジ	11/64(40)X8..... Screw 11/64(40)X8	5
* 483	MH 00E0 519	ソレノイド Solenoid	1
* 484	MH 00A3 691	ガスケット Gasket	1
* 485	MH 00A1 880	横蓋 Arm side cover.....	1
486	M9 1109 004	PW付ブラマイネジ	11/64(40)X8..... Screw 11/64(40)X8	4
* 487	MH 00A4 691	ガスケット Gasket	1
488	M9 0607 050	ミガキ座金	6..... Washer 6.....	2
489	M9 0601 053	バネ座金	6..... Spring washer	2
490	M9 1571 045	ナット	M6..... Nut M6.....	2
491	M9 1118 002	平ネジ	11/64(40)X10..... Screw 11/64(40)X10.....	1
* 492	MH 00A0 321	返し板 Reverse plate	1
* 493	MH 00A0 392	返し駆動腕 Reverse driving crank.....	1
494	M9 1502 022	ボルト	15/64(28)X13..... Bolt 15/64(28)X13.....	1
495	M9 1111 004	ブラマイネジ	11/64(40)X10..... Screw 11/64(40)X10.....	4
496	MN 60A0 620	ナイロンクリップ	HP-5N..... Cord holder	2
497	M9 3003 099	ピンターミナル	(オス)..... Terminal pin (Male)	11
498	MF 01A0 366	コネクターキャップ Connector cap	1
499	M9 1018 099	コネクター	12P..... Nylon connector 12-pole.....	1
500	M9 7003 095	アースコード	(組)..... Ground wire assy.	1
501	M9 4008 099	ナイロンクリップ	HP-8N..... Cord holder	2
502	MF 01A1 366	コネクターキャップ Connector cap	1
503	M9 1020 099	コネクター	6P..... Connector 6-pole	1
504	M9 3002 050	座金 Washer	1
505	MF 01A0 257	押工板 Detector bracket supporter...	1
506	M9 0330 065	C型止メ輪	30..... Retaining ring C-type 30.....	1
507	M9 3001 050	座金	30..... Washer 30.....	1
508	MF 01A0 259	反射板押エスプリング Supporter spring	1
509	MF 01A1 476	スペーサ	B..... Spacer B.....	1
510	MF 01A1 694	反射板	B21(上)..... Speed command disc B21(Up) ...	1
511	MF 01A0 476	スペーサ	A..... Spacer A.....	2
512	MF 01A0 694	反射板	B11(下)..... Speed command disc B11(Down)...	1
513	MF 01A0 682	プーリ Pulley	1
514	M9 1502 002	平ネジ	15/64(28)X12..... Screw 15/64(28)X12.....	2
* 918	MH 00E0 534	タッチスイッチ	(組)..... Touch switch assy.	1
919	MF 01E0 406	検出器	(組)..... Detector bracket assy.	1
920	MF 01E0 682	プーリ	(組)..... Pulley assy.	1

*印は、LG2-3370 専用部品を示します。

10 給油機構
OIL LUBRICATION MECHANISM

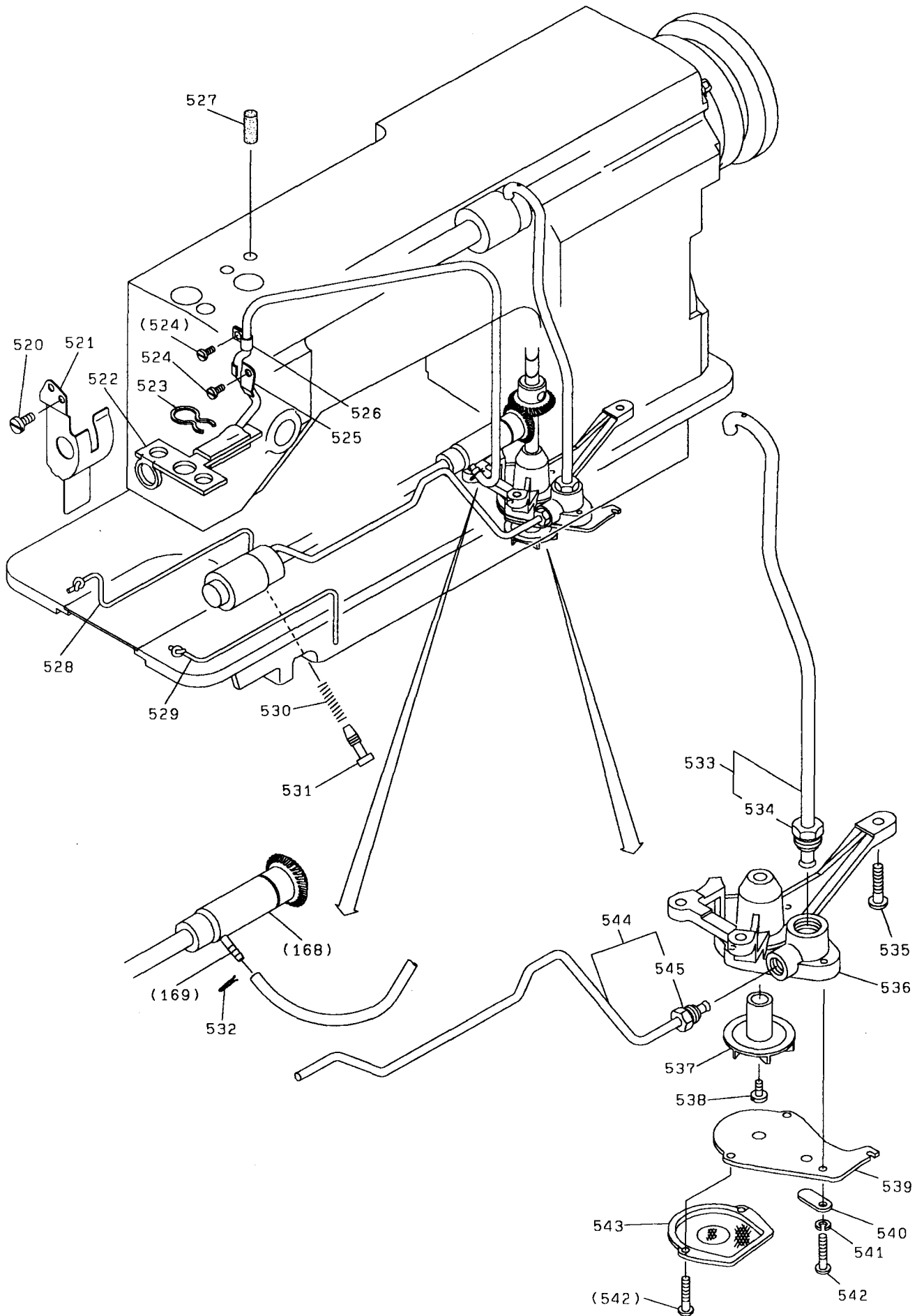

OIL LUBRICATION MECHANISM

Fig. No.	部品コード Parts. No.	部 品 名	Description	使用個数 Amt. Req.
	520 M9 1106 004	ブラマイネジ	11/64(40)X8..... Screw 11/64(40)X8	2
*	521 MH 00A0 873	油防板	(組)..... Arm oil shield assy.	1
*	522 MH 00E0 740	還油フェルト	(組)..... Oil return felt assy.....	1
*	523 MH 00A0 741	フェルト押エ Felt holder	1
	524 M9 1109 002	平ネジ	11/64(40)X7..... Screw 11/64(40)X7	2
*	525 MH 00A0 780	ホルダー Holder	1
*	526 MH 00A1 780	ホルダー Holder	1
	527 MF 01A2 740	給油フェルト	φ 8X30 Oil felt	1
	528 MF 95A0 148	給油紐 Oil wick	1
	529 MF 00A0 148	給油紐 Oil wick	1
	530 MF 80A1 572	ツルマキバネ Coil spring	1
	531 M9 7084 030	油量調節ネジ	15/64(28)..... Oil adjusting screw 15/64(28)	1
	532 MF 01A0 378	還油パイプクリップ Oil return tube clip.....	1
	533 MF 80A1 688	給油パイプ	(組)(上)..... Upper shaft oil tube assy. ...	1
	534 MF 40A1 750	パイプ接続ブッシュ	1/2(28) Oil tube lock bushing 1/2(28)	1
	535 M9 1103 004	ブラマイネジ	11/64(40)X13 Screw 11/64(40)X13.....	3
	536 MF 80A0 783	ポンプケース Oil pump	1
	537 MF 10A0 685	羽根車 Oil pump impeller.....	1
	538 M9 0810 002	平ネジ	1/8(44)X8..... Screw 1/8(44)X8	1
	539 MF 00A2 601	羽根車カバー Oil pump impeller cover.....	1
	540 MF 10A1 742	油量調節弁 Oil adjusting plate	1
	541 M9 0304 053	バネ座金	3.5 Spring washer 3.5	1
	542 M9 0801 004	ブラマイネジ	1/8(44)X13 Screw 1/8(44)X13.....	3
	543 MF 10E0 337	ポンプフィルター Oil pump filter	1
	544 MF 00E0 142	給油パイプ	(組)(下)..... Lower shaft oil tube assy. ...	1
	545 M9 2201 047	パイプ接続ブッシュ	11/32(28)..... Oil tube lock bushing 11/32(28) ...	1

11 付属品 (I)
ACCESSORIES (I)

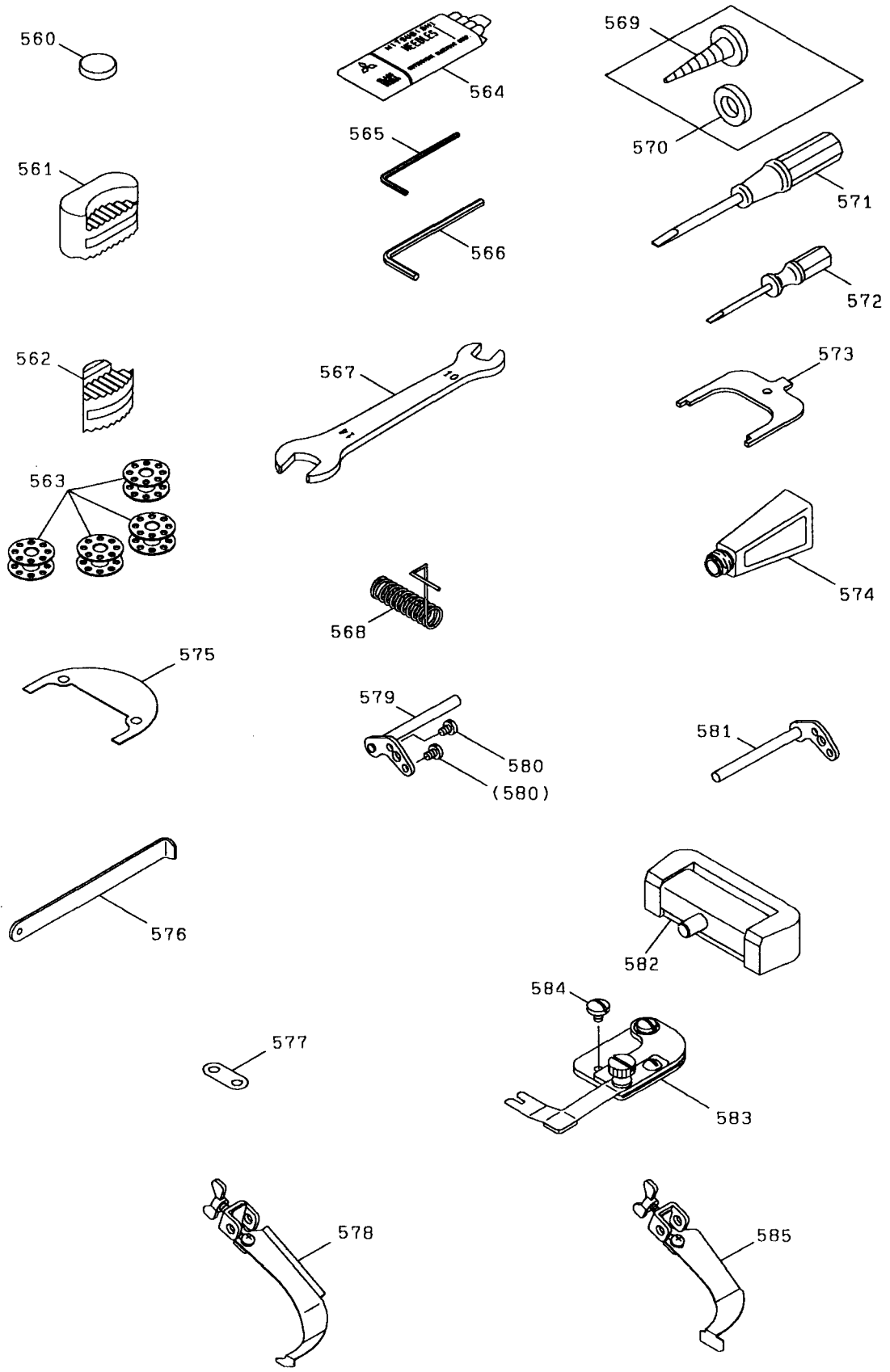

11 付属品 (I)
ACCESSORIES (I)

Fig. No.	部品コード Parts. No.	部 品 名	Description	使用個数 Amt. Req.
560	M9 0701 099	集塵マグネット	Magnet block	1
561	MF 01A0 419	防振ゴム (大)	Head cushion (Large)	2
562	MF 01A0 419	防振ゴム (小)	Head cushion (Small)	2
563	MF 00A0 123	ボビン	Bobbin	4
564	MF 70A0 128	ミシン針 DBX1-2#14	Needle DBX1-2#14	4
565	MF 90A2 976	六角棒スパナ 2	Hexagon socket screw key 2	1
566	MS 02A2 976	六角棒スパナ 3	Hexagon socket screw key 3	1
567	MM 10A1 479	スパナ	Spanner	1
568	MF 10A0 187	糸取りバネ	Thread take-up spring	1
569	M9 0401 041	丸木ネジ 4.5X20	Wood screw for bobbin winder 4.5X20	2
570	M9 0550 050	座金 5	Washer for bobbin winder 5	2
571	MB 02A0 608	ネジ回シ (中)	Screw driver (Middle)	1
572	MB 02A1 608	ネジ回シ (小)	Screw driver (Small)	1
573	MF 01A0 565	反射板調整具	Speed command disc adjusting plate	1
574	MF 60A0 137	油差シ	Oil with oiler	1
* 575	MH 00A0 476	スペーサ (針板用)	Throat plate spacer	1
* 576	MH 00A0 610	ドライバー板	Driver plate	1
* 577	MF 95A0 476	スペーサ (送り歯用)	Drop feed dog spacer	1
* 578	MH 00A0 469	ステッチ定規 (組)	Edge guide assy.	1
* 579	MH 00A1 601	ステッチ定規取付棒 (組)	Edge guide holder	1
580	M9 0909 003	丸平ネジ 9/64(40)X6	Screw 9/64(40)X6	2
* 581	MH 00A2 601	ステッチ定規取付棒 (組)	Edge guide holder	1
582	MF 01E0 418	頭部ヒンジ (組)	Hinge with rubber cushion	2
* 583	MH 00A0 743	分離板 (組)	Separator assy.	1
584	M9 0915 003	丸平ネジ 9/64(40)X6	Screw 9/64(40)X6	2
* 585	MH 00A1 469	ステッチ定規 (組)	Edge guide assy.	1

*印は、LG2-3370 専用部品を示します。

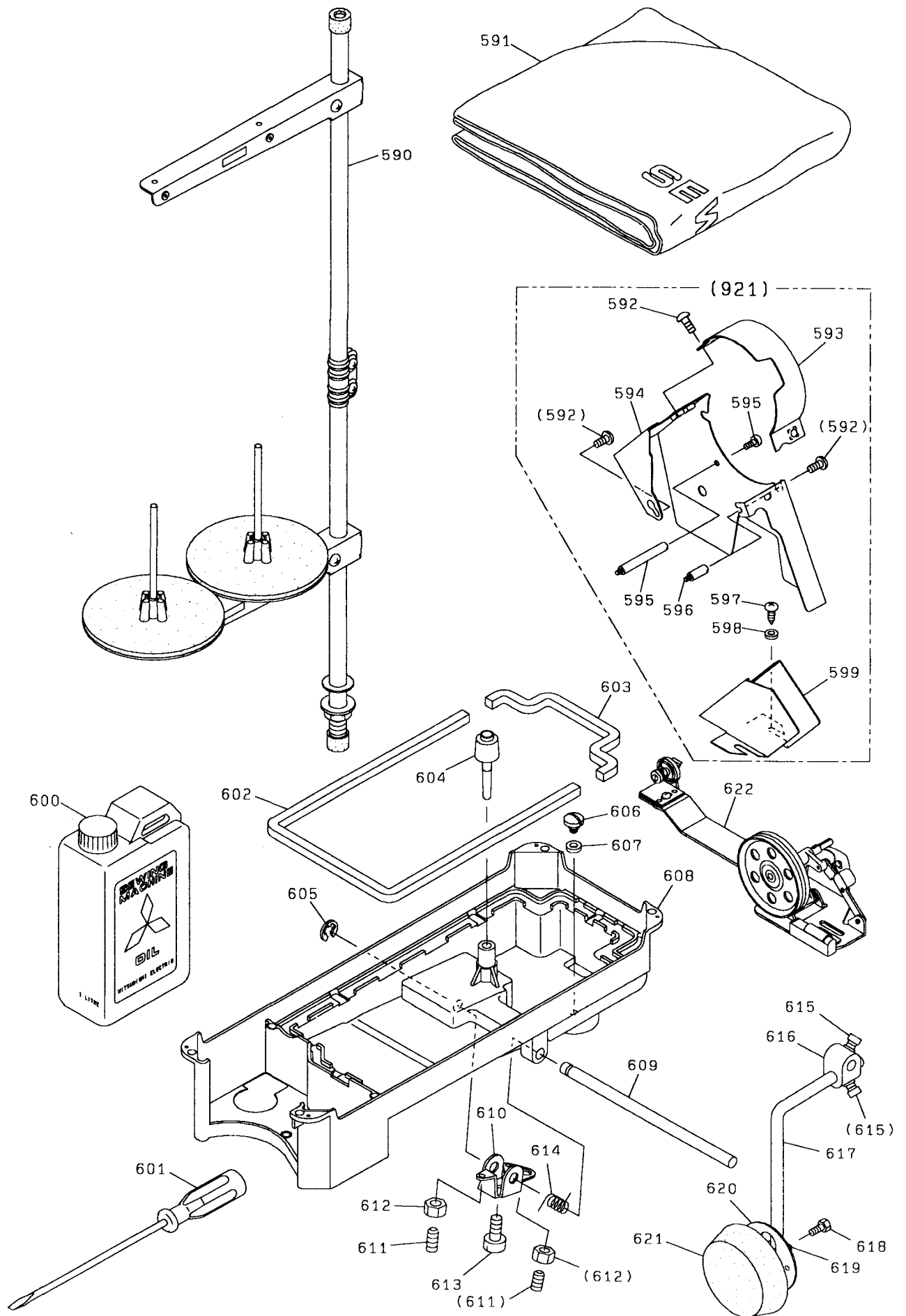

12 付属品 (II)
ACCESSORIES (II)



12 付属品 (II)
ACCESSORIES (II)

Fig. No.	部品コード Parts. No.	部 品 名	Description	使用個数 Amt. Req.
590	MF 40E0 193	糸立装置 (組)	Thread stand assy.	1
591	MF 60A0 734	ビニールカバー	Vinyl cover	1
592	M9 1109 004	座金付ブラマイネジ 11/64(40)X8	Screw 11/64(40)X8	6
* 593	MH 00A0 776	ベルトカバー	Belt cover	1
* 594	MH 00A1 776	ベルトカバー	Belt cover	1
* 595	MH 00A3 601	取付脚 11/64(40)X6	Stud screw 11/64(40)X6	1
* 596	MH 00A4 601	取付脚 11/64(40)X6	Stud screw 11/64(40)X6	1
597	M9 0401 041	丸木ネジ 4.5X20	Wood screw 4.5X20	2
598	M9 0550 050	座金 5	Washer 5	2
* 599	MH 00A2 776	ベルトカバー	Belt cover	1
600	MF 10E0 149	オイルタンク	Oil tank	1
601	MF 00A0 608	ネジ回シ (大)	Screw driver (Large)	1
602	MF 20A3 691	オイルパッキン 1	Gasket for oil reservoir	1
603	MF 20A2 691	オイルパッキン 2	Gasket for oil reservoir	1
604	MF 70A0 578	膝上ゲピン	Knee lifter lifting rod	1
605	M9 0515 065	E型止メ輪 9	Retaining ring E-type 9	1
606	M9 2002 002	平ネジ 5/16(28)X10	Screw 5/16(28)X10	1
607	M9 7001 052	シールワッシャー 8	Seal washer 8	1
608	MF 01A1 139	油槽	Oil reservoir	1
609	MG 75A0 723	膝上ゲ軸	Knee lifter shaft	1
610	MF 20A1 724	膝上ゲレバー	Knee lifter	1
611	M9 1520 001	止メネジ 15/64(28)X27	Set screw 15/64(28)X27	2
612	M9 1501 045	ナット 15/64(28)	Nut 15/64(28)	2
613	M9 1501 007	棒先丸平ネジ 15/64(28)X14.5	Screw 15/64(28)X14.5	1
614	MF 20A1 729	ヒネリバネ	Coil spring	1
615	M9 2001 031	四角ボルト 5/16(18)X13	Bolt 5/16(18)X13	2
616	MF 40A0 784	膝継手	Knee lifter coupling joint	1
617	MF 01A0 728	操作棒	Knee lifter shaft	1
618	M9 1510 022	ボルト 15/64(28)X8	Bolt 15/64(28)X8	1
619	MF 40A0 477	ストッパー	Knee lifter plate stopper	1
620	MF 40A0 737	膝当て板	Knee lifter plate	1
621	MF 40A1 737	膝当て	Knee lifter cover	1
622	MF 01E0 193	糸巻装置 (組)	Bobbin winder assy.	1
* 921	MH 00E0 776	ベルトカバーセット	Belt cover assy.	1

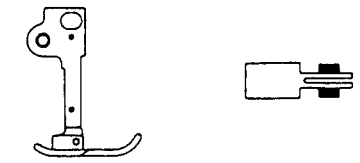
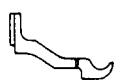
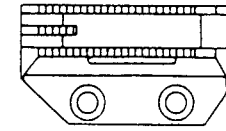
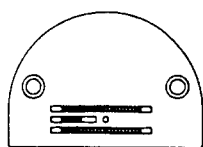
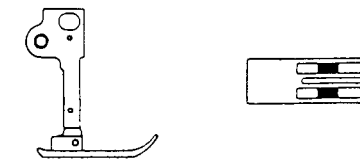
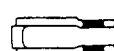
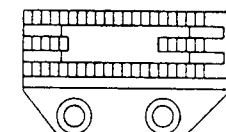
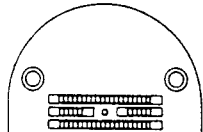
*印は、LG2-3370 専用部品を示します。

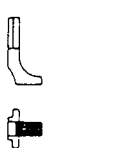
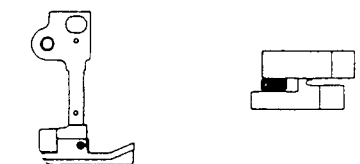
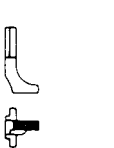
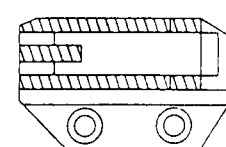
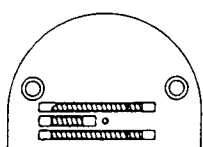
ゲージタイプ Gauge Set Type	押 え 金 Presser Foot	上 送 り 歯 Top Feed Dog	送 り 歯 Drop Feed Dog	針 板 Throat Plate	用 途 Usage
GOM	 MH00B1105	(かき込み型) (Pusher type) 	(p=1.15mm)  MH00B1104	針穴 φ1.9mm Needle Hole φ1.9mm  MH00B1101	標準仕様 いせ込縫い用 中厚素材用 Standard type for ruf- fling prevention of un- even material feed.
HOM	 MH00B2105	 MH00B1294	(p=1.15mm)  MH00B2104	針穴 φ1.9mm Needle Hole φ1.9mm  MH00B2101	伸縮性素材, ブラッシン グ素材用 いせ込縫い用 Suited for stretchy material and plushy materials.
SOM	 MH00B3105	(先引き型) (Puller type)  MH00B3294	(p=1.15mm)	針穴 φ1.6mm Needle Hole φ1.6mm	スカート, スラックスの ベルトステッチ他、各種 ステッチ縫い用 Various types of top- stitching, including top- stitching of skirt and slacks belts. (Stitch width : 2mm)
SAM	 MH00B4105	(先引き型) (Puller type)  MH00B4294	 MH00B3104	 MH00B3101	ワイシャツ, ブラウス, ドレス, ジャケット等の コバステッチ伏せ縫い用 (ステッチ幅1.5mm右段押 え) Edge welt seam top- stitching of men's shirts, blouses, dres- ses, jackets, etc. (Stitch width : 1.5mm right compensating foot)