

**MITSUBISHI
INDUSTRIAL
SEWING
MACHINE**

Model

DU-100

DU-120

classes

**Compound Feed Single-Needle Lockstitch
Compound Feed Double-Needle Lockstitch**

INSTRUCTION FOR OPERATION MANUAL

Main parts name of machine head

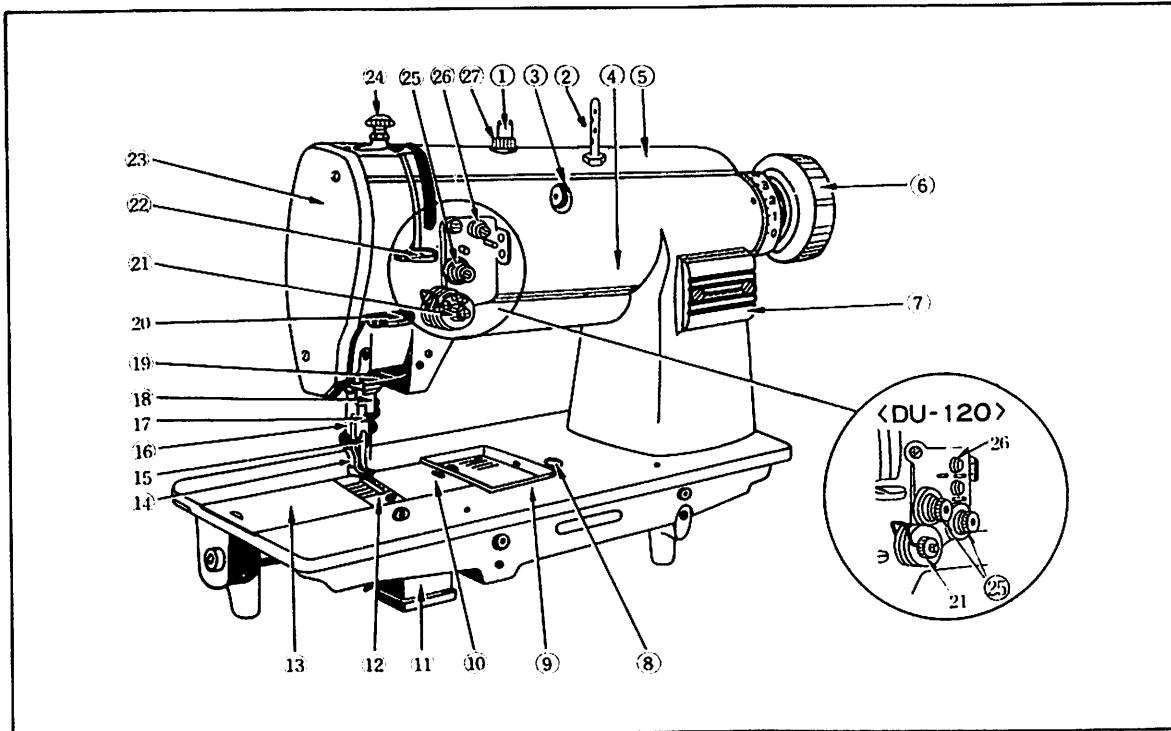

- | | | |
|----------------------------------|----------------------------|------------------------------------|
| 1) Press bar for oil plunger. | 10) Slide plate (right). | 19) Thread guide (lower). |
| 2) Thread guide (top of arm). | 11) Hook saddle (right). | 20) Thread guide (middle) |
| 3) Oil level indicator. | 12) Needle plate. | 21) Thread controller. |
| 4) Arm | 13) Slide plate (left). | 22) Thread guide (upper). |
| 5) Arm top cover | 14) Inside presser foot. | 23) Face plate. |
| 6) Balance wheel. | 15) Outside presser foot. | 24) Thumb screw. |
| 7) Front cover | 16) Presser bar. | 25) Upper thread tension regulator |
| 8) Stitch regulator push button. | 17) Thread guide (needle). | 26) Pre-tension. |
| 9) Bed | 18) Needle bar. | 27) Press stud for oil plunger. |

How to install and adjust the knee lifter

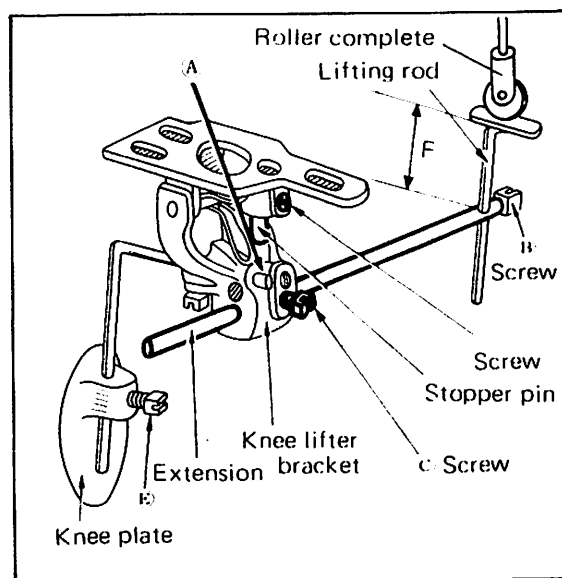
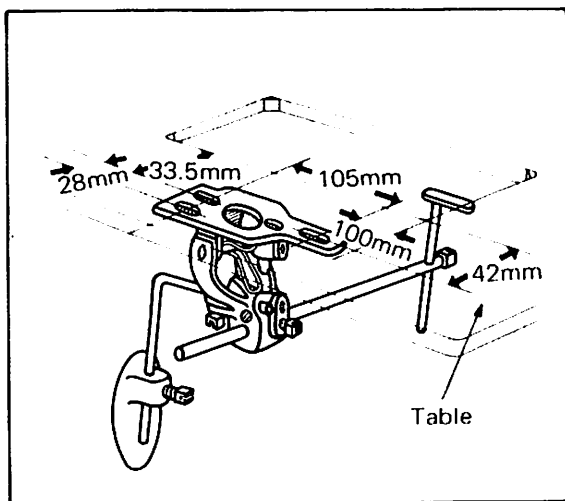

How to use the machine

1. How to attach needle

Note: Before making the following adjustment, switch off the power source by all means.

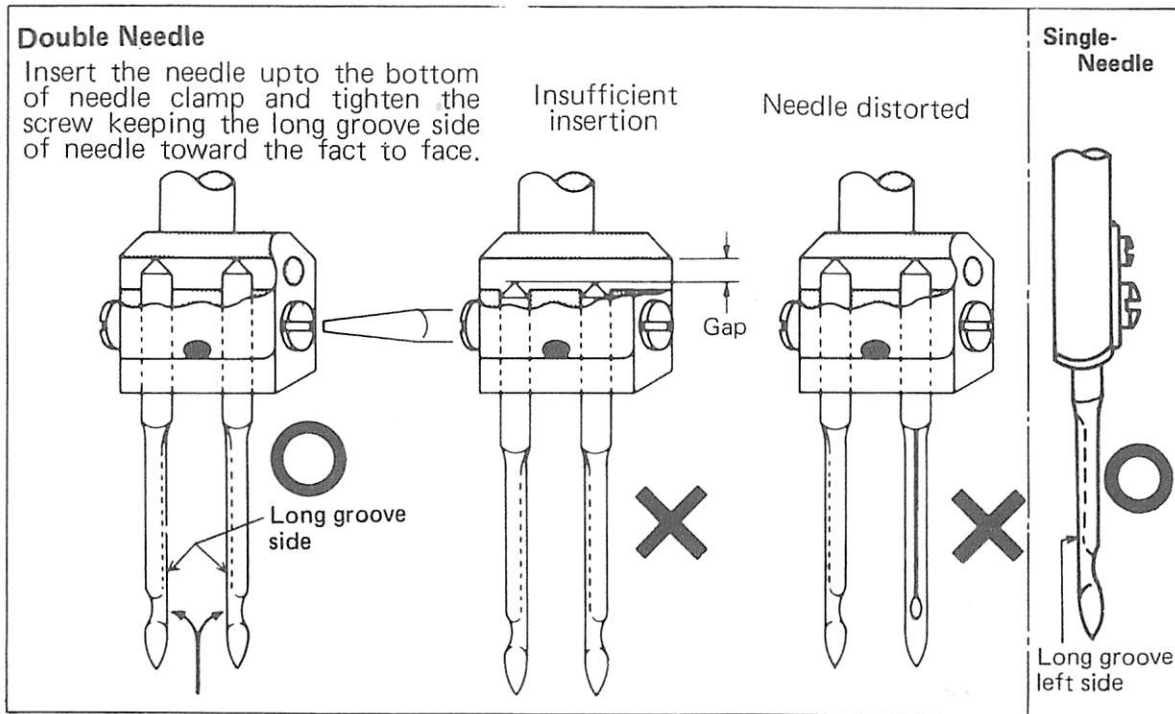

2. How to wind the lower thread on the bobbin

Note: In case of rotate the machine without sewing, keep the presser foot raised.

- Adjustment:
- ** Strength of winding: Particularly in case of nylon or tetoron thread. It is desirable that the bobbin is wound enough loose.
 - ** Uneven winding: In case of uneven winding, adjust the thread guide slightly toward the less wound part of bobbin so that to obtain even winding.
 - ** Winding amount of thread: When the winding amount of thread is excessive loosen the adjusting screw and tighten when insufficient.

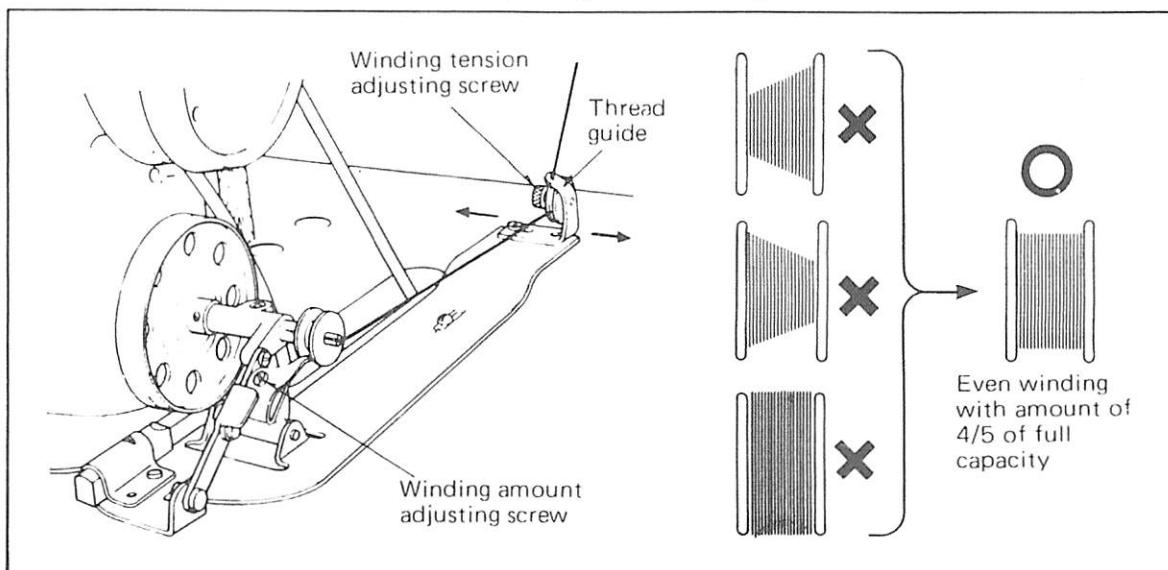

How to use the machine

3. Threading the machine

Note: The thread guide (A) should be positioned just above the thread spool.

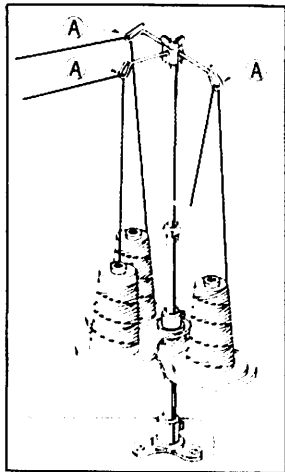

Raise the thread take-up lever to its highest position and thread the upper thread in the following order.

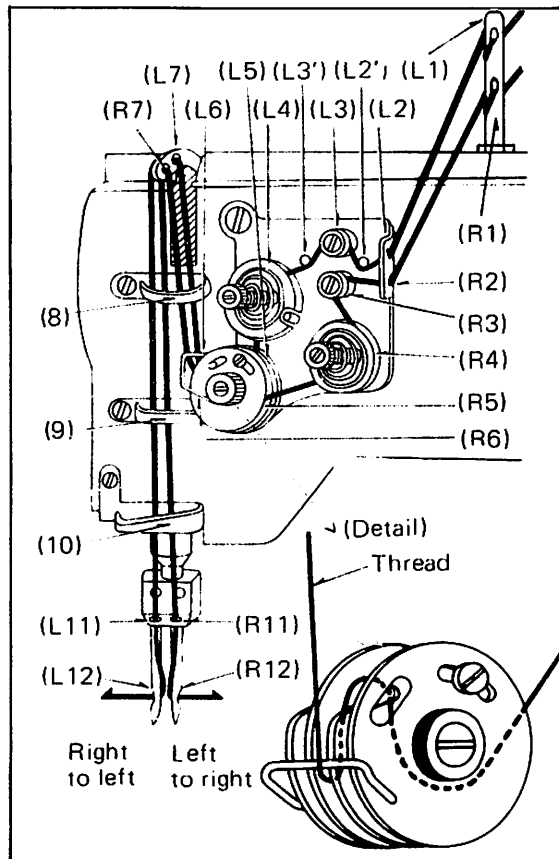

4. Adjustment of stitch length

Stitching length can be adjusted with the stitch regulator push button on the bed and the balance wheel.

1) Pushing the push button down and turn the balance wheel slowly toward you.

2) So that the push button goes down further and the balance wheel running.

At this time set the graduation of the dial on the Balance Wheel with the marking on the arm and then release the push button shown in Fig.

Caution: NEVER depress the button while the machine is running.

To change the direction of feed for back tacking, depress feed reverse lever to lowest position until back tack is completed.

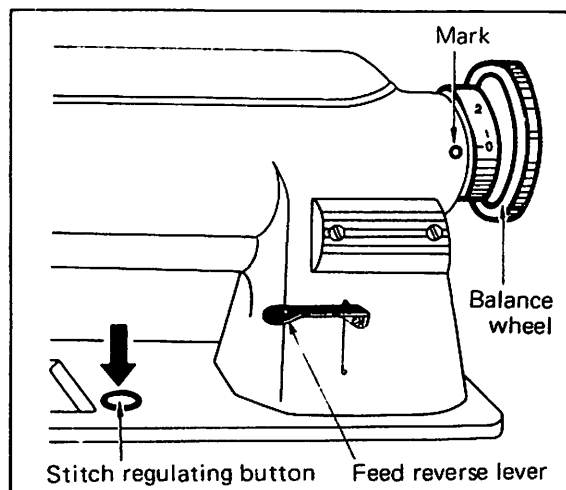

5. How to place the bobbin into the shuttle hook

Note: In case of placing the bobbin into the shuttle hook, place the bobbin by making winding toward the thread in correct direction shown in Fig.

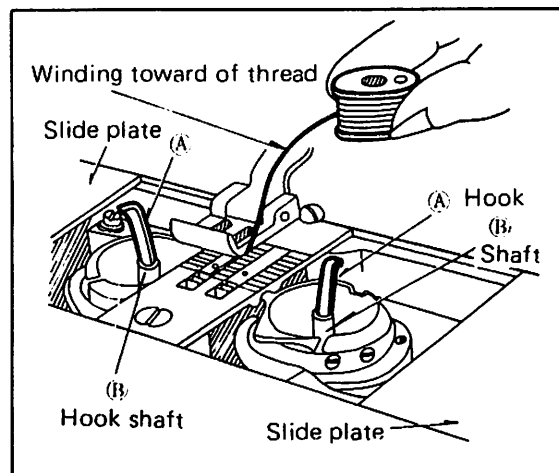

How to use the machine

6. Lower threading

1) Lead the end of thread to the groove of the shuttle hook ① shown in Fig. and through the horn ②, pull the thread out.

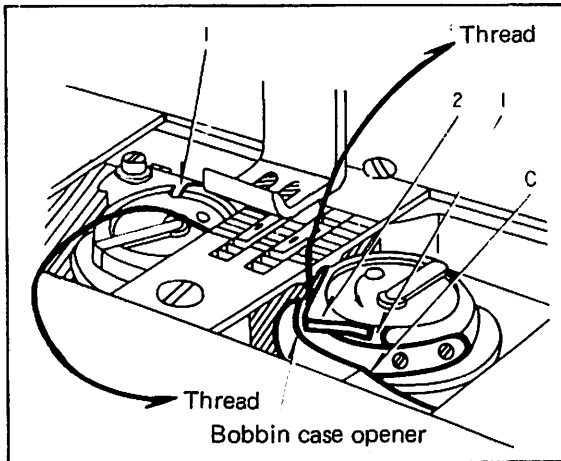

2) Holding the end of the upper thread by left hand and turn the balance wheel slowly. Pull out the lower thread and hold it on the other side from the underneath of the presser foot.

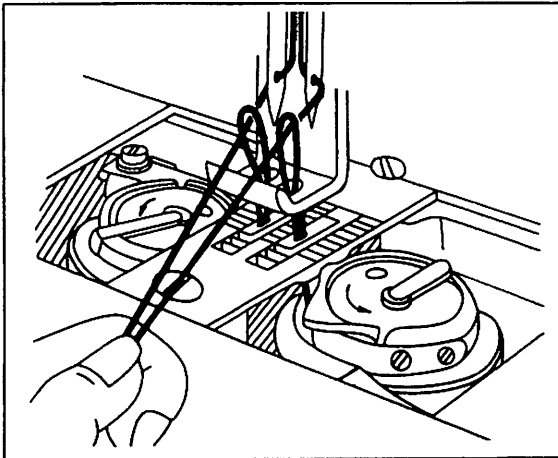

9. Lower thread tension

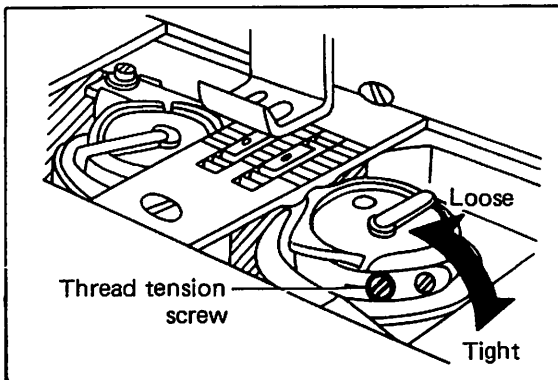

7. Adjustment of thread tension

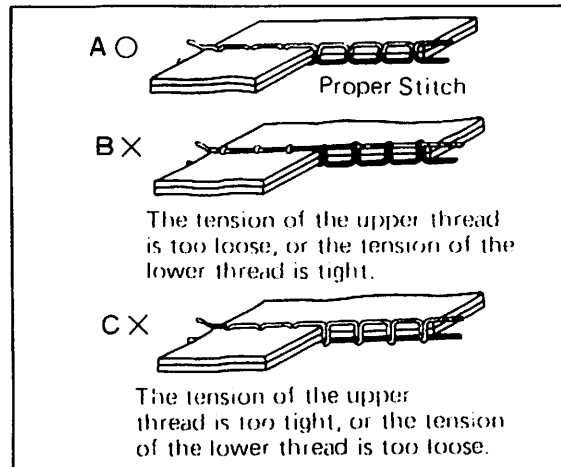

8. Upper thread tension

- ** Upper thread is adjusted according to the lower thread tension.
- ** Upper thread tension is adjusted by tension regulating thumb nut.

For special fabric sewing with special thread, the desired tension can be obtained by adjusting the strength and operating range of thread take-up spring.

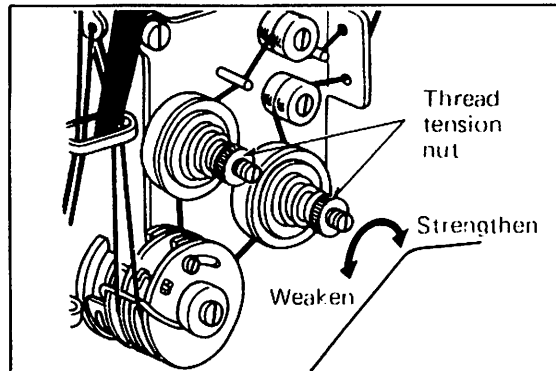

10. Adjustment of pressure on presser foot

Pressure on the presser foot is to be adjusted in accordance with materials to be sewn.

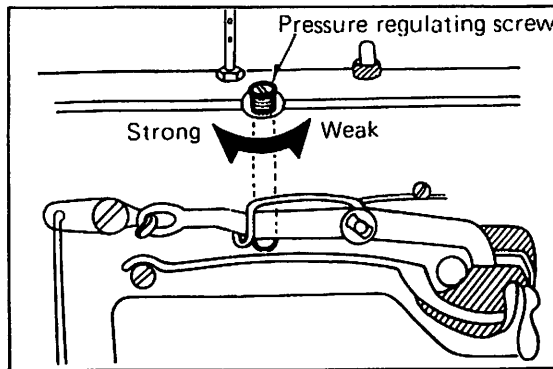

How to use the machine

11. SAFETY CLUTCH DEVICE:

Safety clutch device is installed to prevent the hook and timing belt from damage in case the thread is caught into the hook when the machine is loaded abnormally during operation.

1) FUNCTION OF SAFETY CLUTCH.

- 1) When the safety clutch acts, the timing belt pulley will be unloaded, then the rotation of hook driving shaft will stop. The arm shaft only will rotate, and stop the operation of machine.
- 2) Clean the thread thoroughly which is caught into the hook.
- 3) Turn the timing belt bushing by hand, and check whether the hook driving shaft rotates lightly and properly, place the clutch device as it was.

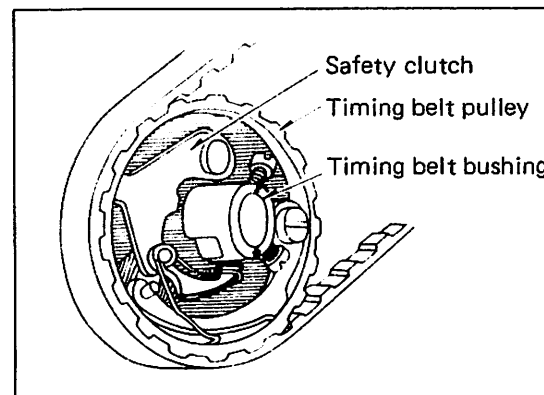
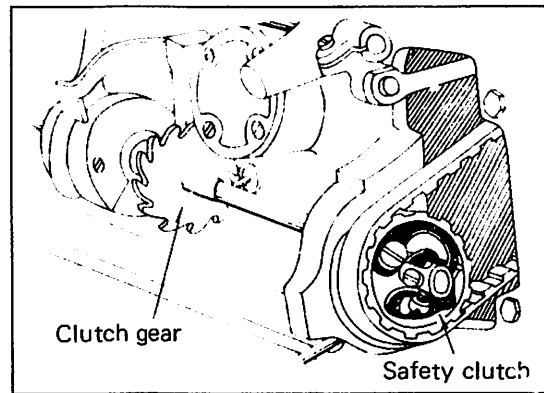

2) HOW TO SET THE SAFETY CLUTCH.

- 1) While pressing down the push button on the opposite side of bed by left hand, turn the balance wheel slowly by right hand away from you as shown in the figure.
- 2) The balance wheel will stop by the gearing plate, but turn the balance wheel more firmly.
- 3) Release the push button.

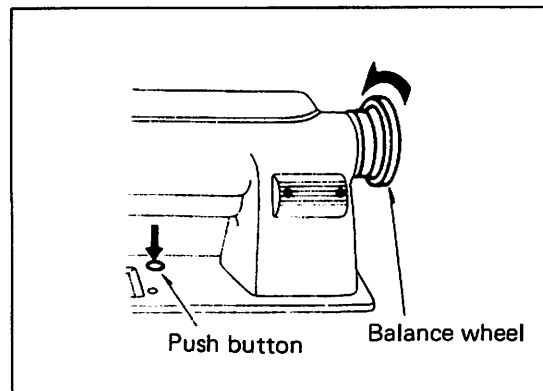

- 4) As shown in the Figure, the safety clutch device is set.

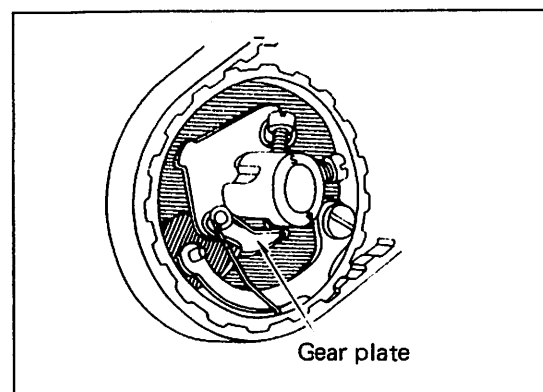

Precaution before starting to operate

1. Lubrication-1

Before starting to operate pour oil upto the position, arm, bed and hook saddle of oil tank.

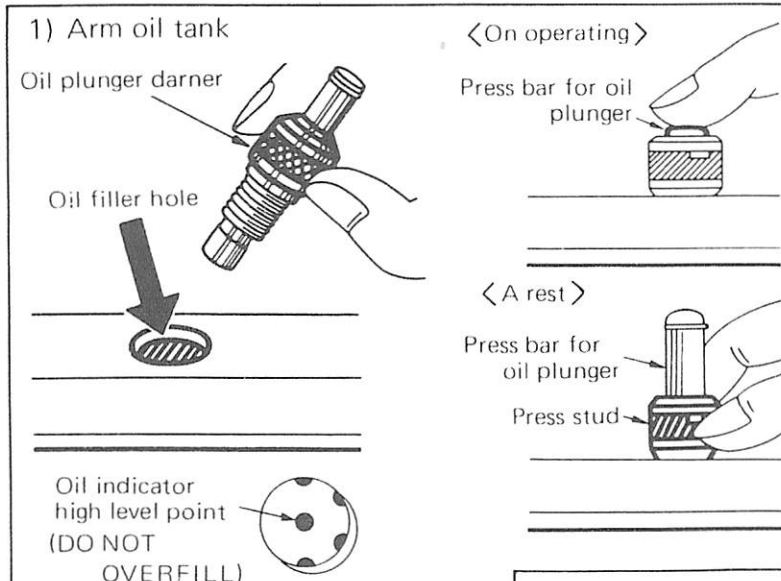

Lubrication-2

The volume of lubrications

..... 5 - 6 drops.

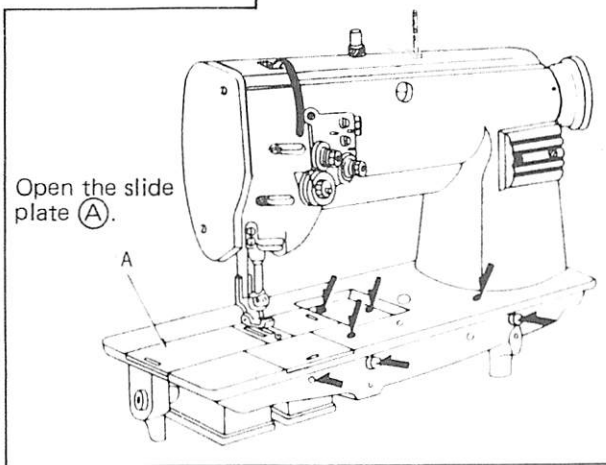
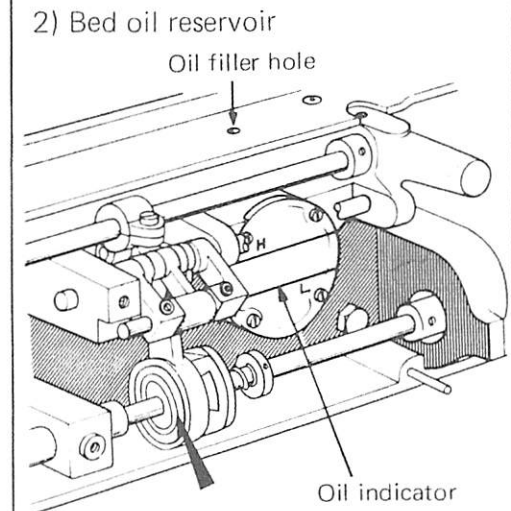
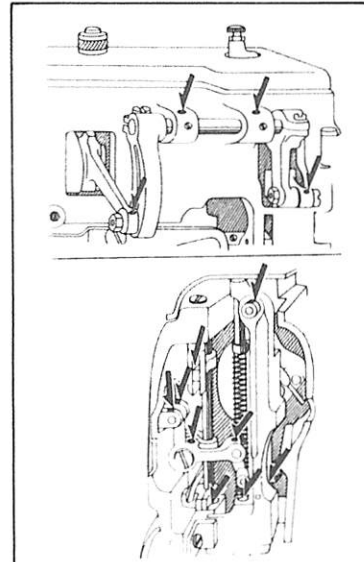

2. Adjustment of rotating hook oil flow regulator

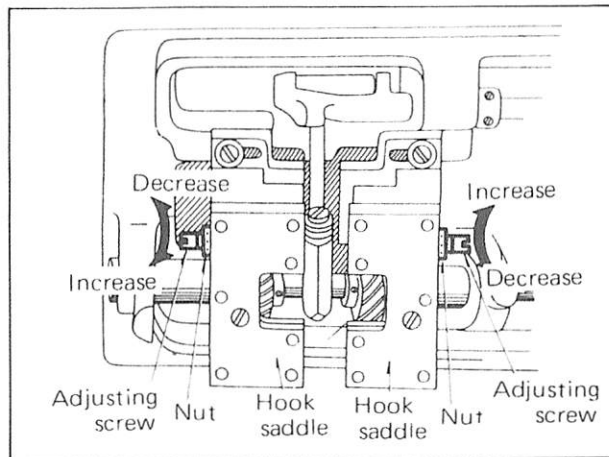
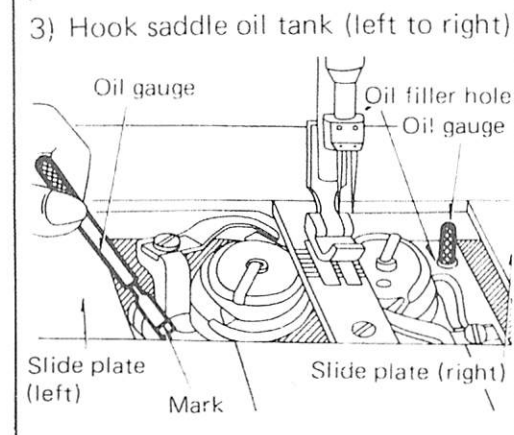

How to mount vibration-preventing rubber with table

The vibration-preventing rubber is used to prevent the machine from vibrating and thereby to provide smooth operation of the machine. Fit these rubber at the four corners of the table as shown in Fig.

- **Achieve spot facing** of 20 mm radius and 13 mm depth at the four corners of the table. Be sure to give smooth facing to the face A where spot facing is achieved.
- **Nail the vibration-preventing rubbers** down at the four corners of the table as shown in Fig.

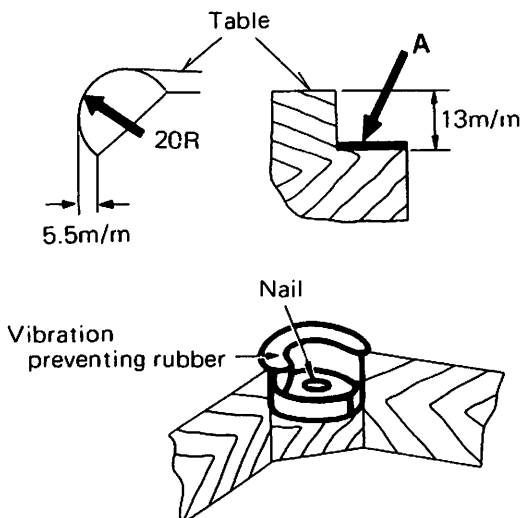

Specifications

Model <Single needle>	DU-100-12	DU-100-22	DU-105-12	DU-105-22
Material weight	Heavy			
Max. speed (spm)	3500	2500	3000	2500
Hook size	Regular	Large	Regular	Large
Reverse lever	No		Yes	

Model <Double needle>	DU-120-12	DU-120-22	DU-125-12	DU-125-22	
Material weight	Heavy material				
Max. speed (spm)	3000	2500			
Hook size	Regular	Large	Regular	Large	
Reverse lever	No	No	Yes	Yes	
Needle gauges	mm	6.4, 9.5, 12.7, 16, 19, 25.4			
	in	1/4, 3/8, 1/2, 5/8, 3/4, 1			

[Common Specifications]

Max. stitch length	7mm (3 1/2 spi)	
Needle-bar stroke	33.4mm (1-5/16")	
Walking-foot stroke	2 - 6mm (5/64 - 1/4")	
Presser-foot clearance	Knee lifter	12.7mm (1/2")
	Hand	9.0mm (23/64")
Space at right of needle	245mm (9-5/8")	
Needle type	Organ	DPx17 #23
	Singer	135x17 #23
	Schmetz	37 : 20 Nm 160
Bed dimensions	517 x 178mm (20-3/8 x 7")	

- Needle type (Organ needles are standard.)

MITSUBISHI ELECTRIC CORPORATION
 HEAD OFFICE MITSUBISHI DENKI BLDG MARUNOUCHI TOKYO 100 TELEX J24532 CABLE MELCO TOKYO
 MITSUBISHI ELECTRIC CORPORATION

Printed in Japan