

# 三菱工業用ミシン部品カタログ

## MITSUBISHI Industrial Sewing Machine Parts Catalog

Model  
DB-130E

目次	INDEX	Page
1. 機 構 図	Total assembly	
2. 本 体 関 係	Arm bed & its accessories	2
3. 本 体 関 係	Arm bed & its accessories	4
4. 天 秤 ・ 上 軸 関 係	Thread take-up lever & arm shaft mechanism	6
5. 針 棒 ・ 豎 軸 関 係	Needle bar & vertical shaft mechanism	8
6. 送 り 調 節 器 関 係	Stitch length regulator mechanism	10
7. 押 エ 関 係	Presser foot mechanism	12
8. 水 平 送 り 軸 ・ 上 下 送 り 軸 関 係	Feed rock shaft & feed lifting shaft mechanism	14
9. 下 軸 ・ カ マ 関 係	Rotating hook shaft & rotating hook mechanism	16
10. 給 油 関 係	Lubrication mechanism	18
11. 付 属 品 箱 関 係	Accessory box & accessories	20
12. 油 槽 ・ ソノ他 付 属 品 関 係	Oil reservoir & other accessories	22

 三菱電機株式会社

197805

DB-130E形 機構図  
TOTAL ASSEMBLY

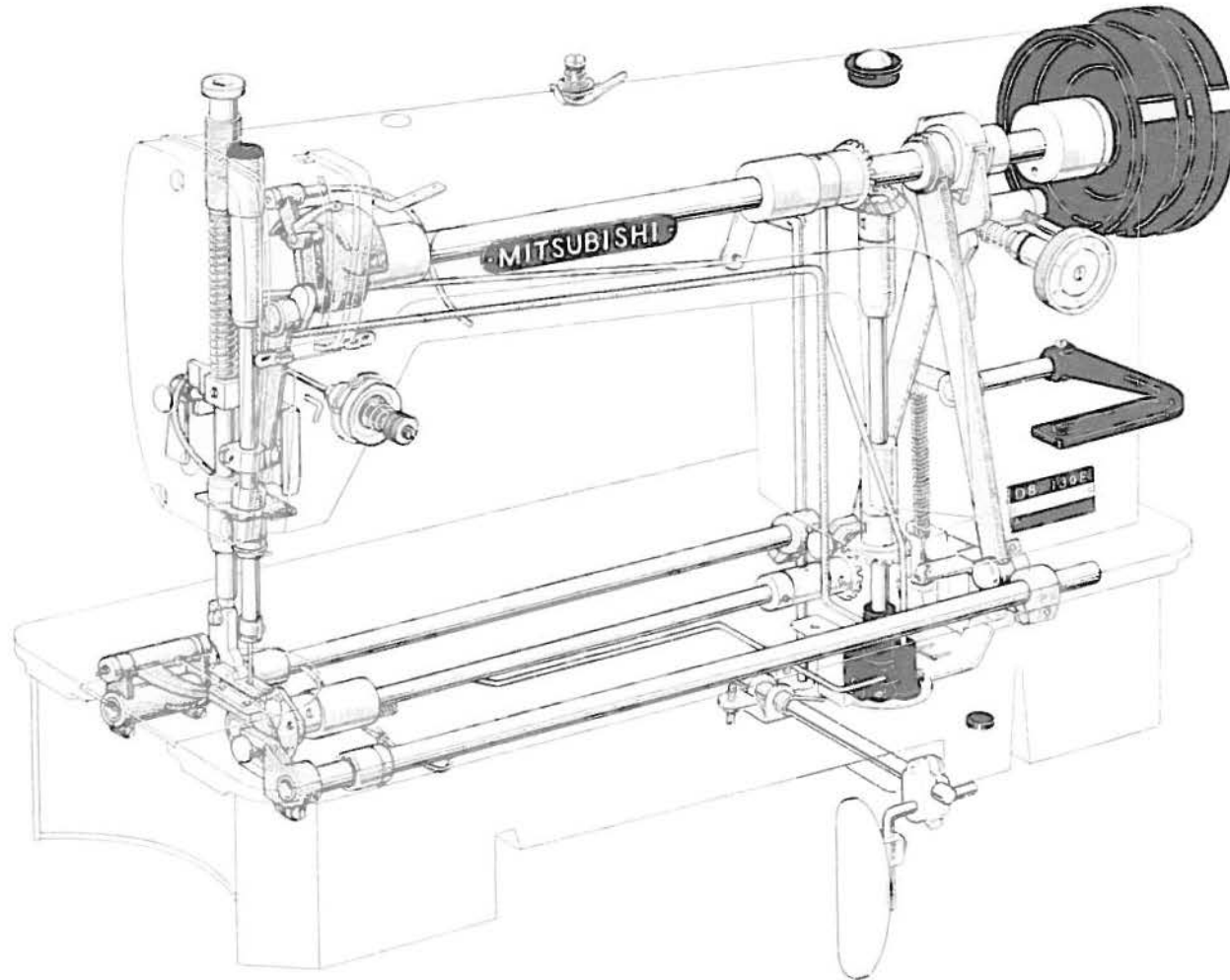

DB-130E-10

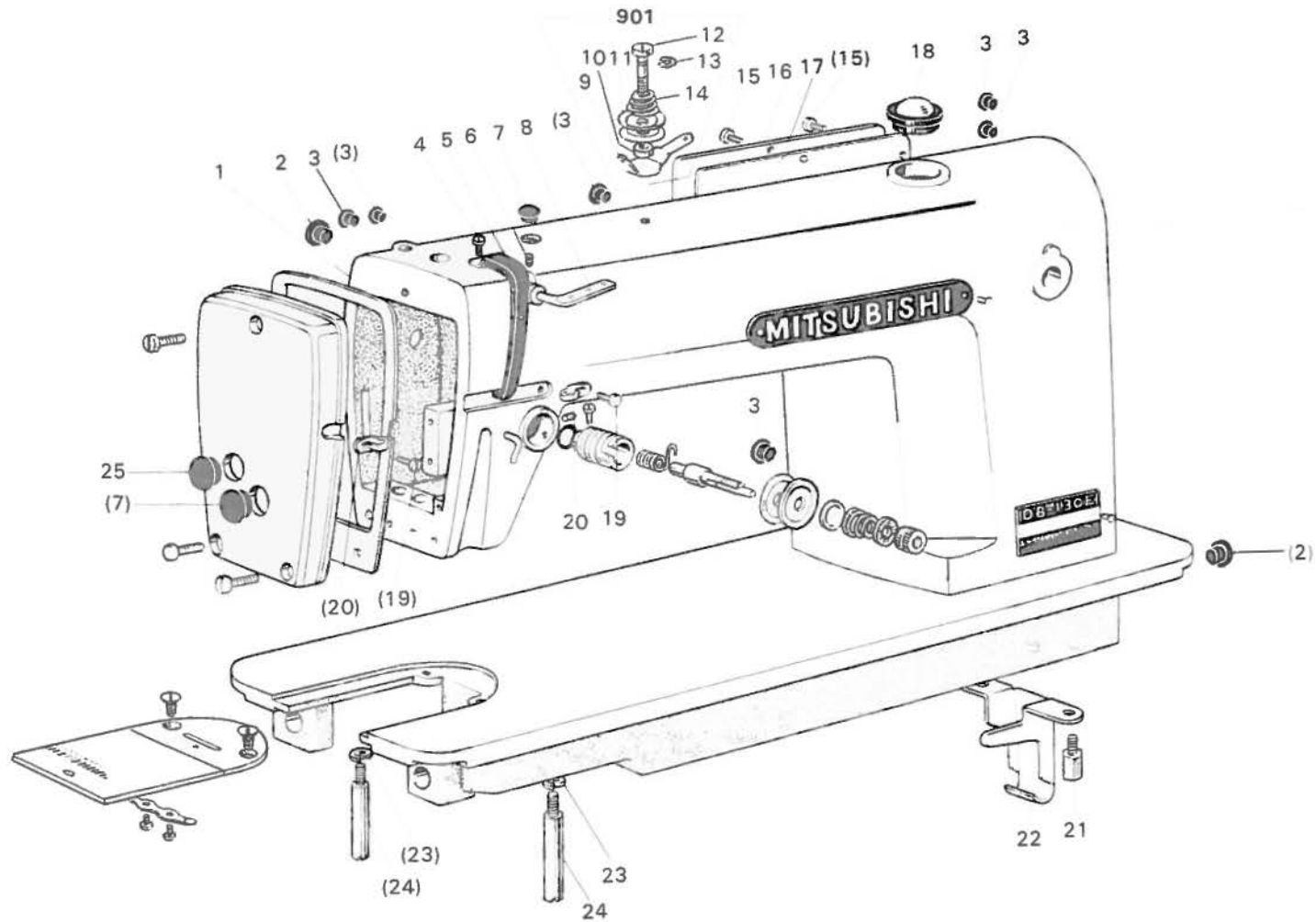

本体関係

ARM BED & ITS ACCESSORIES

Fig. No.	部品コード Parts No.	資材コード Ref No	部 品 名	Description	使用 個数 Amt. Req	共通部品 Common Parts												
						DB-130E-10	DB-130E-10L	DB-130E-11	DB-130E-12	DB-130E-12-7	DB-130E-13	DB-130E-22	DB-130-10	DB-130-11	DB-130-12			
1	MF 70E0 164	W229939G01	アームベッド	Arm & bed	1													
2	M9 1900 080	W501374H01	ゴム栓 19	Rubber plug (19 )	2													
3	M9 0880 080	W50 320H01	ゴム栓 (8.8φ)	Rubber plug (8.8 )	5													
4	M9 1107 002	W500092H01	平ネジ 11/64(40)×5.5	Screw (for Fig.5) 11 64(40)×5.5	2													
5	MF 10A0 584	W468291H01	天祥カバー	Thread take-up cover	1													
	MF 17B0 584	W458150H01	天祥カバー (2倍カマ)	Thread take up cover	1													
6	M9 1108 001	B 503846H01	頭ナシ止メネジ 11 64(40)×5.5	Set screw (for Fig.8) 11 64(40)×5.5	1													
7	M9 1180 080	W502069H01	ゴム栓 (11.8 )	Rubber plug (11.8.)	2													
8	MF 10A0 180	B 409034H01	糸案内上 (三ノ目糸掛)	Three hole thread guide	1													
9	MF 70A0 180	W481446H01	糸案内 (フリテンション)	Threed guide for pre-tension	1													
10	MF 20A0 476	W470268H01	スペーサ ( )	Spacer for pre-tension	1													
11	MF 10A1 555	W501636H01	テンションディスク ( )	Tension discs for pre-tension	2													
12	M9 1104 016	W470267H01	設付丸平ネジ 11 64(40)×16	Screw type tension stud	1													
13	M9 0503 065	S 592411H03	E型止メ 3	E-type stop ring	1													
14	MF 20A0 245	W475419H01	円ネ (フリテンション)	Tension spring for pre-tension	1													
901	MF 70E0 550	W341647G01	プリテンション ( )	Pre-tension complete	1													
15	M9 1101 004	W466810H01	フラマイネジ 11 64(40)×8	Screw (for Fig 16) 11 64(40)×8	6													
16	MF 70A0 880	W341642H01	側蓋	Arm side cover	1													
17	MF 70A0 691	W341643H01	ガスケット (横蓋)	Gasket (for Fig.16)	1													
18	MF 20A0 135	P 674006X01	油窓	Oil check window	1													
19	M9 0909 003	W501901H01	丸平ネジ 9 64(40)×6	Screw (for Fig.20) 9 64(40)×6	1													
20	MF 10A0 181	W452151H01	糸案内 (中)	Arm & face plate thread guide	2													
	MF 17B0 181	W470968H01	糸案内 (中) (2倍カマ)	Arm & face plate thread guide	2													
21	M9 1502 031	W481675H01	特殊ホルト 15 64(28)×25	Special bolt 15 64(28)×25	2													
22	MF 70A0 150	W481676H01	脚 (右)	Leg (right)	1													
23	M9 0621 053	S 561111H02	ネ金 6 (左)	Spring washer (for Fig.24)	2													
24	MF 10A0 151	W452343H01	脚 (左)	Leg (left)	2													
25	M9 5002 080	W472710H01	ゴム栓 19 黒色	Rubber plug (black 19 )	1													

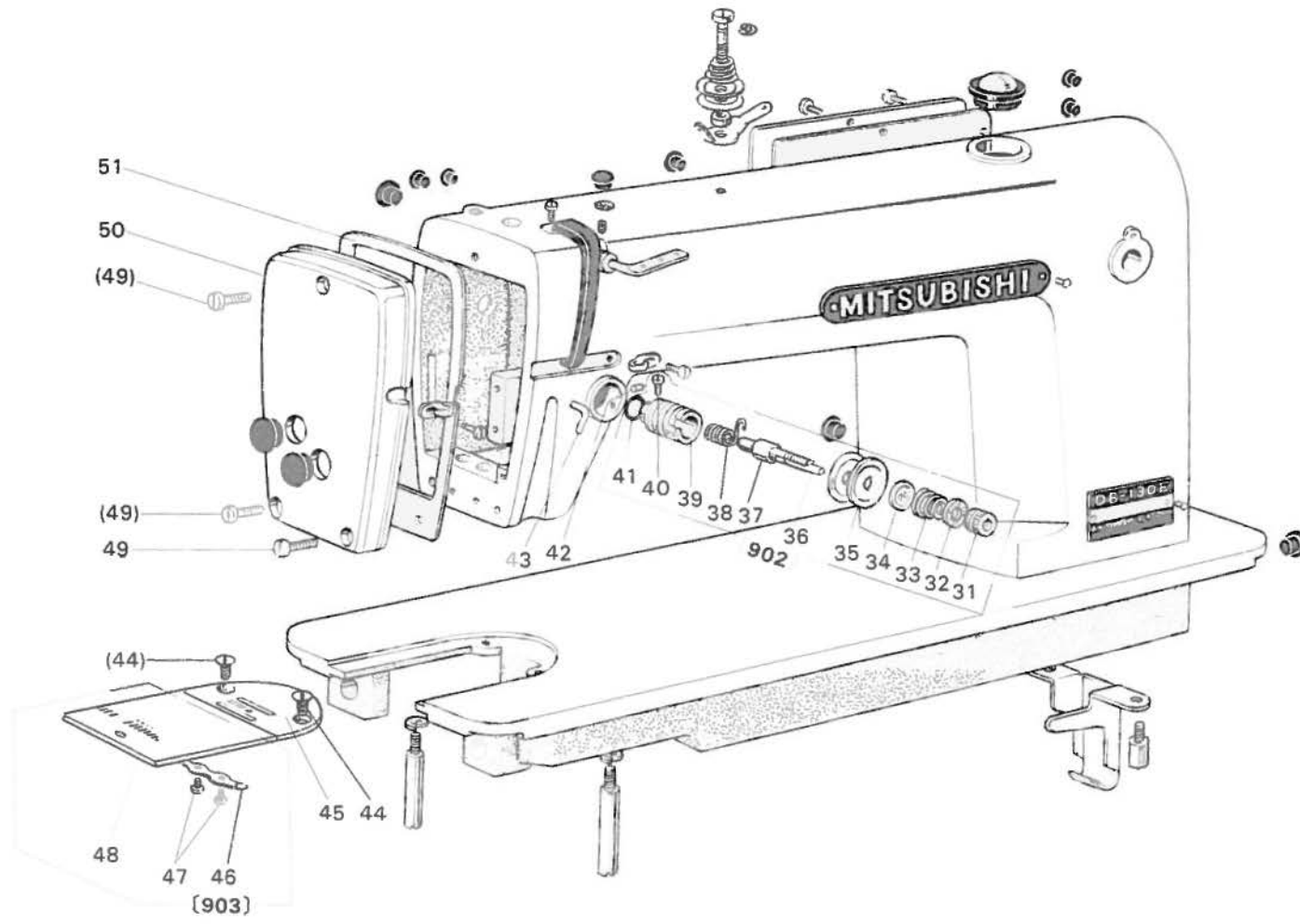

本体関係

ARM BED & ITS ACCESSORIES

Fig. No.	部品コード Parts No.	資材コード Ref. No.	部品名	Description	使用 個数 Amt Req	共通部品 Common Parts														
						DB-130E-10	DB-130E-10L	DB-130E-11	DB-130E-12	DB-130E-127	DB-130E-13	DB-130E-22	DB-130-10	DB-130-11	DB-130-12					
31	M9 1608 046	W476469H01	ナット (上糸調節器) 1/4 40	Thread tension regulating thumb nut	1															
32	MT 60A0 802	W476470H01	回り止メ (上糸調節器)	Thumb nut revolution stopper	1															
33	MF 11D0 245	W461780H01	円錐バネ (上糸調節器)(標準)	Thread tension spring	1															
	MT 60A0 245	W473335H01	円錐バネ (上糸調節器)(薄物L)	Thread tension spring	1															
	MF 10A0 245	W450071H01	円錐バネ (上糸調節器)(薄物)	Thread tension spring	1															
	MF 23C0 245	W461786H01	円錐バネ (上糸調節器)(極厚)	Thread tension spring	1															
34	MM 11A0 556	W477611H01	調子皿押エ (上糸調節器)	Thread tension releasing disc	1															
35	MF 10A0 555	W444059H01	調子皿 (上糸調節器)	Thread tension discs	2															
36	M9 0204 060	B 509216H01	ピン (上糸調節器) 2φ×28.4	Thread tension releasing pin	1															
37	MF 10A0 553	B 419178H01	調子棒 (上糸調節器)	Thread tension stud	1															
38	MF 10A0 187	W475488H01	糸取りバネ (上糸調節器)(標準)	Thread take-up spring	1															
	MF 71D0 187	W481632H01	糸取りバネ (上糸調節器)(薄物)	Thread take-up spring	1															
	MF 12B0 187	W461748H01	糸取りバネ (上糸調節器)(厚物)	Thread take-up spring	1															
39	MF 10A0 709	W453140H01	ブッシュ (上糸調節器)	Thread tension regulator bushing	1															
40	M9 0901 002	W500741H01	平ネジ 9/64(40)×4	Set screw (for Fig 37)	1															
41	M9 1501 085	P 648001X01	Oリング NO-KS15	Rubber ring (for Fig. 39)	1															
902	MF 70E0 210	W462751G02	上糸調節器(組)(標準)	Thread tension regulator complete	1															
	MF 72E0 210	W335284G02	上糸調節器(組)(厚物)	Thread tension regulator complete	1															
	MF 71E0 210	W341658G01	上糸調節器(組)(薄物L)	Thread tension regulator complete	1															
	MF 73E0 210	ZM00041	上糸調節器(組)(極厚)	Thread tension regulator complete	1															
42	M9 1508 001	B 509088H01	頭ナシ止メネジ 15/64(28)×8	Set screw (for Fig 902) 15 64(28)×8	1															
43	MF 70A1 180	W481679H01	糸案内(下)	Thread guide (under)	1															
44	M9 1102 011	W500197H01	丸皿ネジ 11/64(40)×7	Screw (for Fig. 45) 11 64(40)×7	2															
45	MF 10A0 101	W326261H01	針板 (B1.6)	Needle plate (B1.6)	1															
	MF 24D0 101	W322714H01	針板 (A1.2)	Needle plate (A1.2)	1															
	MF 11D0 101	W324529H01	針板 (A1.6)	Needle plate (A1.6)	1															
	MF 12B0 101	W324587H01	針板 (B2.5)	Needle plate (B2.5)	1															
	MF 26B0 101	W322721H01	針板 (B2.6)	Needle plate (B2.6)	1															
46	MF 10A0 471	B 419207H01	板バネ (スベリ板)	Spring (for Fig 48)	1															
47	M9 0604 002	B 509070H01	平ネジ 3.32(56)×2.2	Screw (for Fig 46) 3.32(56) 2.2	2															
48	MF 10A0 470	B 419208H01	スベリ板	Slide plate	1															
903	MF 10E0 470	W461757G01	スベリ板(組)	Slide plate complete	1															
49	M9 1102 004	W467880H01	フラマイネジ 11 64(40)×10	Screw (for Fig 50) 11 64(40)×10	3															
50	MF 70A0 830	W343906H01	面板	Face plate	1															
51	MF 20A1 891	W470264H01	ガスケット(面板)	Gasket (for Fig 50)	1															

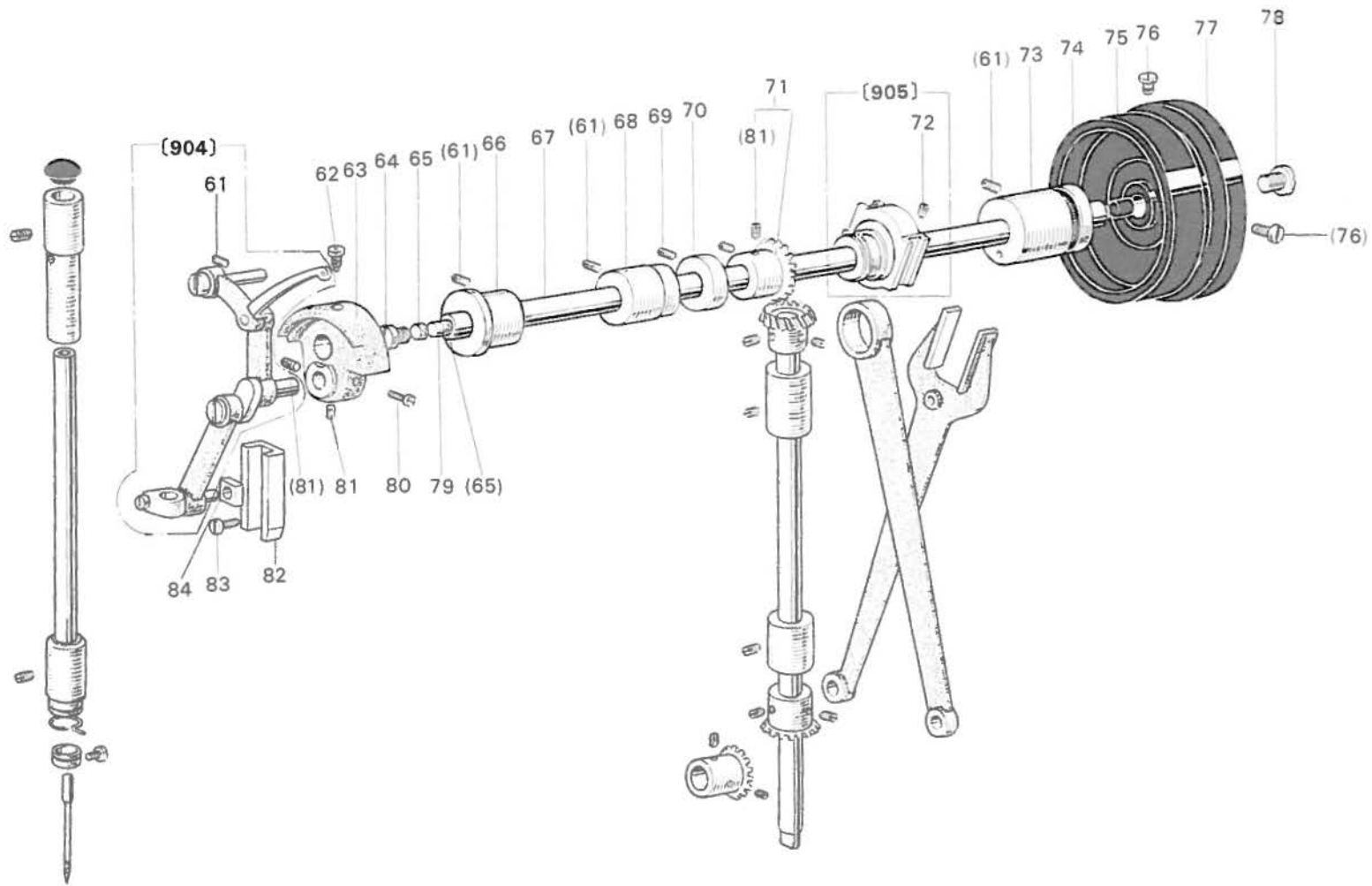

天秤・上軸関係

THREAD TAKE-UP LEVER & ARM SHAFT MECHANISM

Fig. No	部品コード Parts No	資材コード Ref No	品名	Description	使用 個数 Amt. Req.	共通部品 Common Parts														
						DB-130E-10	DB-130E-10L	DB-130E-11	DB-130E-12	DB-130E-127	DB-130E-13	DB-130E-22	DB-130-10	DB-130-11	DB-130-12					
904	MF 10E0 580	W324586G01	天秤針ク(組)(標準)	Thread take-up lever complete	1	○	○	○	○	○	○	○	○	○	○	○	○	○	○	○
	MF 71E0 580	W324586G05	天秤針ク(組)(薄物)	Thread take-up lever complete	1	○	○	○	○	○	○	○	○	○	○	○	○	○	○	○
	MF 12E0 580	W335283G01	天秤針ク(組)(厚物)	Thread take-up lever complete	1	○	○	○	○	○	○	○	○	○	○	○	○	○	○	○
	MF 17E0 580	W335291G01	天秤針ク(組)(2倍カマ)	Thread take-up lever complete	1	○	○	○	○	○	○	○	○	○	○	○	○	○	○	○
61	M9 1516 001	W500006H01	頭ナシ止メネジ 15 64(28)×15	Set screw (for Fig.904) 15 64(28)×15	4	○	○	○	○	○	○	○	○	○	○	○	○	○	○	
62	M9 1802 006	B 503851H01	棒先平ネジ 9/32(28)×14	Set screw (for Fig.63) 9 32(28)×14	1	○	○	○	○	○	○	○	○	○	○	○	○	○	○	
63	MF 70A0 383	W481447H01	クランク(標準)	Crank	1	○	○	○	○	○	○	○	○	○	○	○	○	○	○	
	MF 71D0 383	W471445H02	クランク薄物L	Crank	1	○	○	○	○	○	○	○	○	○	○	○	○	○	○	
	MF 21D0 383	W472544H01	クランク薄物	Crank	1	○	○	○	○	○	○	○	○	○	○	○	○	○	○	
64	M9 2001 011	W502474H01	丸皿オン 5 16(28)×7	Screw for arm shaft front 5 16(28)×7	1	○	○	○	○	○	○	○	○	○	○	○	○	○		
65	MF 10A2 740	W500003H01	フェレット上軸	Felt for arm shaft front	3	○	○	○	○	○	○	○	○	○	○	○	○	○	○	
66	MF 70A0 232	W481453H01	上軸左	Arm shaft bushing (left)	1	○	○	○	○	○	○	○	○	○	○	○	○	○	○	
67	MF 70A0 230	W341641H01	上軸	Arm shaft	1	○	○	○	○	○	○	○	○	○	○	○	○	○	○	
68	MF 70A0 234	W481 52H01	上軸	Arm shaft bushing (middle)	1	○	○	○	○	○	○	○	○	○	○	○	○	○	○	
69	M9 1602 001	W500036H01	頭ナシ止メネジ 1 4(40) 4	Set screw (for Fig.70) 1 4(40)×4	2	○	○	○	○	○	○	○	○	○	○	○	○	○	○	
70	MF 70A0 352	W476422H01	カラ上	Arm shaft collar	3	○	○	○	○	○	○	○	○	○	○	○	○	○	○	
71	MF 10A0 331	P 611003X01	傘歯車(上軸)(ネシ付)	Bevel gear (arm shaft)	1	○	○	○	○	○	○	○	○	○	○	○	○	○	○	
72	M9 1508 001	B 509088H01	頭ナシ止メネジ 15 64(28)×8	Set screw (for Fig.905) 15 64(28)×8	2	○	○	○	○	○	○	○	○	○	○	○	○	○	○	
905	MF 70E0 280	W481451G01	偏心輪(組)(送りカム)	Feed cam complete	1	○	○	○	○	○	○	○	○	○	○	○	○	○	○	
73	MF 70A0 233	W481413H01	上軸メタル右	Arm shaft bushing (right)	1	○	○	○	○	○	○	○	○	○	○	○	○	○	○	
74	M9 1473 086	W481476H01	オイルシール上軸右	Oil seal for arm shaft right	1	○	○	○	○	○	○	○	○	○	○	○	○	○	○	
75	M9 0740 080	W478175H0	ゴム栓上軸 7 4 10	Rubber plug for arm shaft (right)	1	○	○	○	○	○	○	○	○	○	○	○	○	○	○	
76	M9 1502 002	W500509H01	ネジ 15 64(28)×12	Set screw (for Fig.77) 15 64(28)×12	4	○	○	○	○	○	○	○	○	○	○	○	○	○	○	
77	MF 10A0 682	W453500H01	スミ	Balance wheel	1	○	○	○	○	○	○	○	○	○	○	○	○	○	○	
78	M9 2201 003	W46 726H01	丸平ネジ 11 32(28)×10	Screw (for Fig 67) 11 32(28)×10	1	○	○	○	○	○	○	○	○	○	○	○	○	○	○	
79	MF 10A0 500	W501905H01	アルミ栓上軸	Alumi-plug for arm shaft (front)	1	○	○	○	○	○	○	○	○	○	○	○	○	○	○	
80	M9 1801 002	W500306H01	ネジ 9 32(28)×13	Set screw (for Fig.63) 9 32(28)×13	1	○	○	○	○	○	○	○	○	○	○	○	○	○	○	
81	M9 1606 001	P 911000X01	頭ナシ止メネジ 1 4 40 7	Set screw (for Fig.63) 1 4(40)×7	4	○	○	○	○	○	○	○	○	○	○	○	○	○	○	
82	MF 10A0 662	W44 056H01	クラクイト案内	Needle bar connecting link guide	1	○	○	○	○	○	○	○	○	○	○	○	○	○	○	
83	M9 1110 002	W50029 H01	ネジ 11 64(40)×8	Screw (for Fig.82) 11 64(40)×8	2	○	○	○	○	○	○	○	○	○	○	○	○	○	○	
84	MF 10A0 325	W44393 0	タテ	Square block (for Fig.904)	1	○	○	○	○	○	○	○	○	○	○	○	○	○	○	



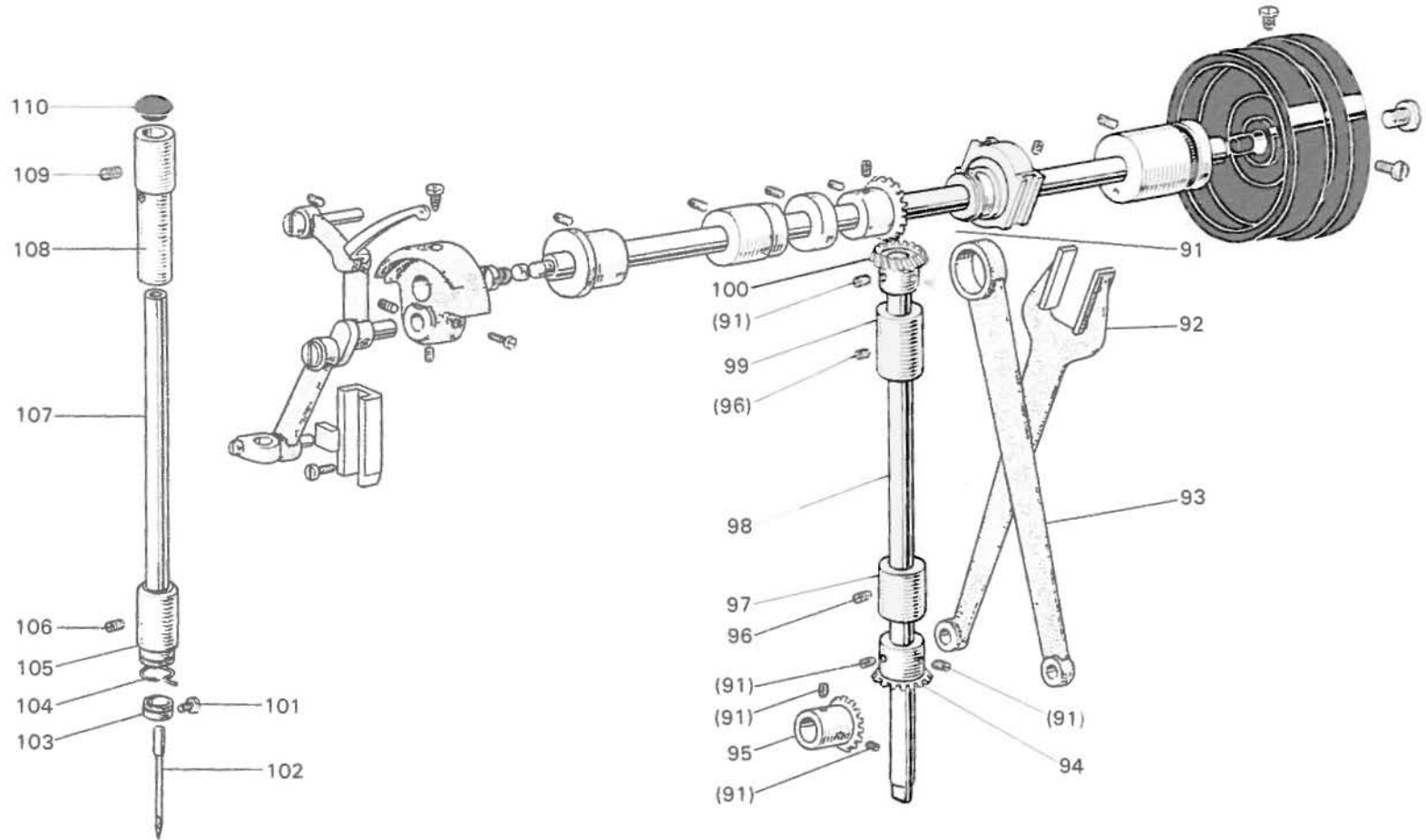

針棒・豎軸関係

NEEDLE BAR & VERTICAL SHAFT MECHANISM

Fig. No.	部品コード Parts No.	資料コード Ref No	部品名	Description	使用 個数 Amt Req	共通部品 Common Parts												
						DB-130E-10	DB-130E-10L	DB-130E-11	DB-130E-12	DB-130E-12.7	DB-130E-13	DB-130E-22	DB-130-10	DB-130-11	DB-130-12			
91	M9 1606 001	P 911000X01	頭ナシ止メネジ 1 4(40)×7	Set screw (for Fig.97) 1 4(40)×7	6													
92	MF 10A0 744	W320448H01	フタ又	Feed forked connecting rod	1													
	MF 26B0 744	W327698H01	フタ又 (7mm)	Feed forked connecting rod (7mm feed)	1													
93	MF 70A0 384	W450961H01	クランクロッド (連接棒)	Crank rod (feed lifting rock)	1													
94	MF 10A0 334	P 611001X01	傘歯車 (豎軸下)(ネジ付)	Bevel gear (vertical shaft lower)	1													
95	MF 10A0 332	P 611002X01	傘歯車 (下軸)(ネジ付)	Bevel gear (hook shaft)	1													
96	M9 1508 001	B 509088H01	頭ナシ止メネジ 15 64(28)×8	Set screw (for Fig 97) 15 64(28)×8	2													
97	MF 70A0 522	W481418H02	豎軸メタル下	Vertical shaft bushing (lower)	1													
	MF 74B0 522	W481696H01	メタル下 2音カマ	Vertical shaft bushing (lower)	1													
98	MF 70A0 520	W481437H01	豎軸	Vertical shaft	1													
99	MF 70A0 521	W481418H01	メタル上	Vertical shaft bushing (upper)	1													
100	MF 10A0 333	P 611000X01	傘歯車 上ネジ付	Bevel gear (vertical shaft upper)	1													
101	M9 0802 003	W502074H01	ネジ 1 8(44) 4.5	Needle clamp screw 1 8(44)×4.5	1													
	MF 70A0 128	S 970010 01	針 DBX1-2-14	Needle DBX1-2-14	1													
	MF 71D0 128	S 970010H03	針 DBX1-2-11	Needle DBX1-2-11	1													
102	MF 21D0 128	S 970001H01	針 DAX1-11	Needle DAX1-11	1													
	MF 72B0 128	S 970010H02	針 DBX1-2-21	Needle DBX1-2-21	1													
	MF 23C0 128	S 970002H04	針 DBX1-23	Needle DBX1-23	1													
103	MF 10A2 181	W50	針棒(標準)	Needle bar thread guide	1													
	MF 21D0 181	W46 2 H01	針棒(薄物)	Needle bar thread guide	1													
104	MF 10A1 181	W5020 3H01	針棒メタル下	Needle bar bushing thread guide	1													
105	MF 10A0 664	W450055H01	針棒メタル上	Needle bar bushing (lower)	1													
	MF 17B0 664	W457585H01	針棒メタル下 2音カマ	Needle bar bushing (lower)	1													
106	M9 1102 001	W500489H01	頭ナシ止メネジ 11 64(40)×2.7	Set screw (for Fig.105) 11 64(40)×2.7	1													
	MF 10A0 660	W450053H01	針棒	Needle bar	1													
	MF 71D0 660	W482338G01	針棒 L	Needle bar	1													
107	MF 11D0 660	W461764H01	針棒	Needle bar	1													
	MF 12B0 660	W461770H01	針棒	Needle bar	1													
	MF 17B0 660	W461796H01	針棒 2音カマ	Needle bar	1													
108	MF 70A0 663	W481449H01	針棒上	Needle bar bushing (upper)	1													
109	M9 1503 001	B 508971H01	止ネジ 15 64(28) 4.5	Set screw (for Fig.108) 15 64(28)×4.5	1													
110	M9 0880 080	W501320 0	ゴム垫 8.8	R bber pl g 8.8 (for Fig.108)	1													

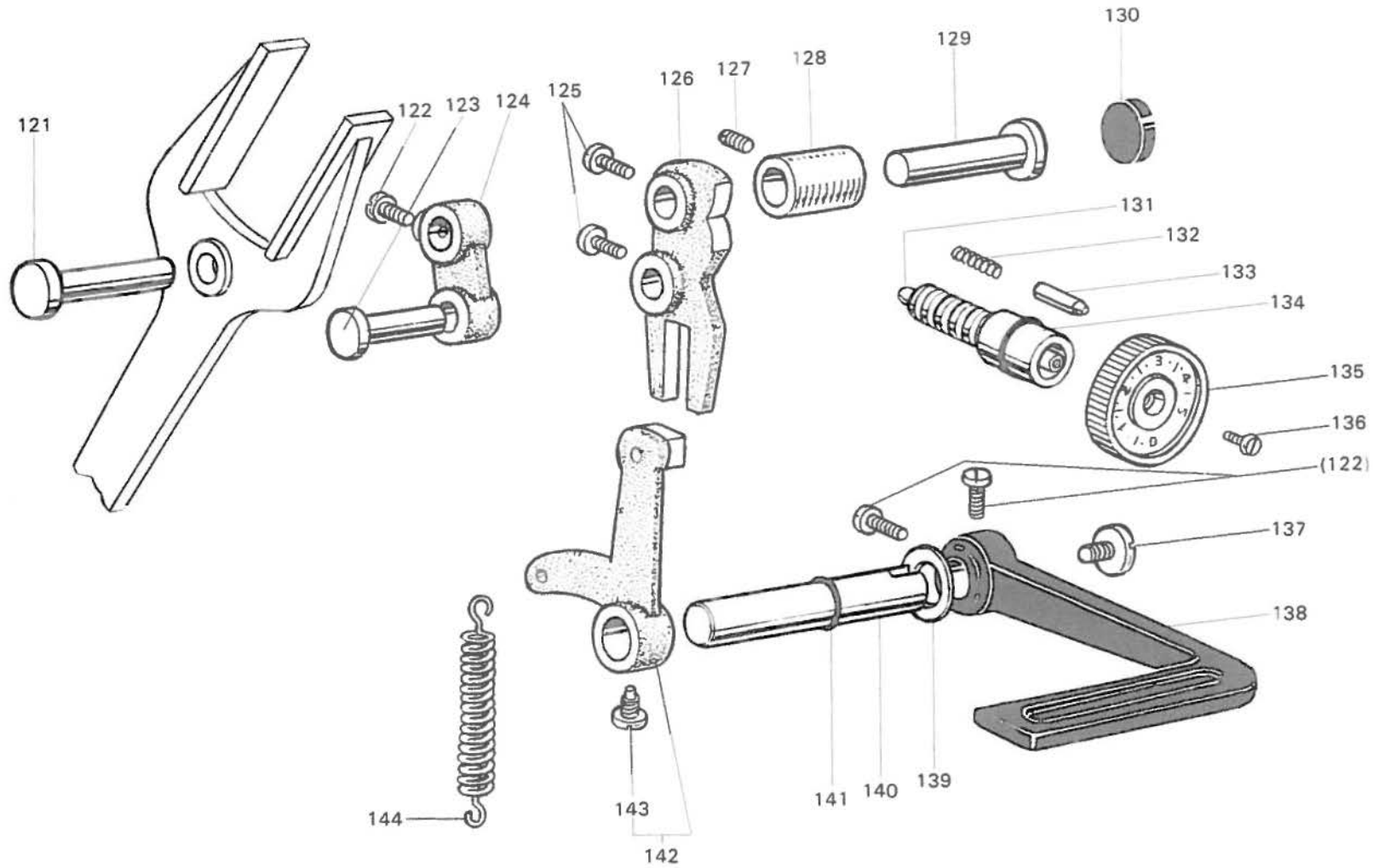

送り調節器関係

STITCH LENGTH REGULATOR MECHANISM

Fig. No	部品コード Parts No	資材コード Ref No	品名	Description	使用 件数 Amt Req.	共通部品 Common Parts											
						DB-130E 10	DB-130E 10L	DB-130E 11	DB-130E 12	DB-130E 127	DB-130E 13	DB-130E 22	DB-130-10	DB-130-11	DB-130-12		
121	M9 0718 063	W481425H01	段付キ軸(フタ又) 7.2φ×19	Set pin (for Fig.92) 7.2φ×19	1												
122	M9 1501 002	W502945H01	平ネシ 15 64(28)×8.5	Set screw (for Fig 121) 15 64(28)×8.5	3												
123	M9 0905 063	W501377H01	ヒン 案内テコ継キ	Set pin (for Fig 124)	1												
124	MF 70A0 153	W481677H01	連接桿 案内テコ継キ	Feed connecting l k	1												
125	M9 1504 002	B 508963H01	平ネシ 15 64(28)×10	Set screw (for Fig 126) 15 64(28)×10	2												
126	MF 10A0 152	W447221H01	案内テコ	Feed regulator	1												
	MF 74B0 152	W336661H01	案内テコ (7mm)	Feed regulator (7mm. feed)	1												
127	M9 1513 001	B 509060H01	噛ナシ上メネシ 15 64(28)×11	Set screw (for Fig.128) 15 64(28)×11	1												
128	MF 70A0 750	W479396H02	フッシユ 案内テコ	Feed regulator bushing	1												
129	M9 0904 063	W479395H01	段付キ軸 (案内テコ)	Set pin (for Fig 126)	1												
130	M9 2001 080	W479394H01	ゴム栓 案内テコ 20,×4	Rubber plug (for Fig.129) 20	1												
131	MF 10A0 640	W447227H01	ネシ	Screw bar	1												
132	MF 10A2 572	B 509164H01	ノレ巻ハネ 戻り止メ	Spring (for Fig.133)	1												
133	MF 10A0 852	B 419163H01	戻り止メ目 タイヤル	Stopper pin (for Fig.135)	1												
134	M9 1000 085	S 648001H06	Oリング P10 ネン	O-ring (for Fig.131) P10	1												
135	MF 10A0 631	W331475H01	ダイヤル目 0-5	Stitch length regulator dial (0-5)	1												
	MF 11D0 631	W331486H01	ダイヤル目加減 0-4	Stitch length regulator dial (0-4)	1												
	MF 26B0 631	W331487H01	ダイヤル (縫目加減) 0-7	Stitch length regulator dial (0-7)	1												
136	M9 1209 002	B 503887H01	平ネジ 3 16(28)×8	Screw (for Fig.135) 3 16(28)×8	1												
137	M9 1207 003	B 509288H01	丸平ネジ 3 16(28)×6.5	Screw (for Fig.138) 3 16(28)×6.5	1												
138	MF 26B0 632	W465387H01	レハ (縫目加減)	Reverse sewing lever	1												
139	M9 5003 053	B 503895H01	ハネ座金 (レバー)	Spring washer (for Fig.138)	1												
140	MF 10A0 633	W450088H01	軸 (縫目加減軸)	Shaft (for Fig.138)	1												
141	M9 0600 085	S 648001H01	Oリング P6 軸	O-ring (for Fig.140) P6	1												
142	MF 10E0 635	W462614G01	目加減 コロ・ネシ付	Reverse sewing crank	1												
143	M9 1501 007	B 509256H01	丸平ネシ 15 64(28)×14.5	Set screw (for Fig 142)	1												
144	MF 10A0 572	W447225H01	レ巻ハネ 縫目	Spring (for Fig 142)	1												

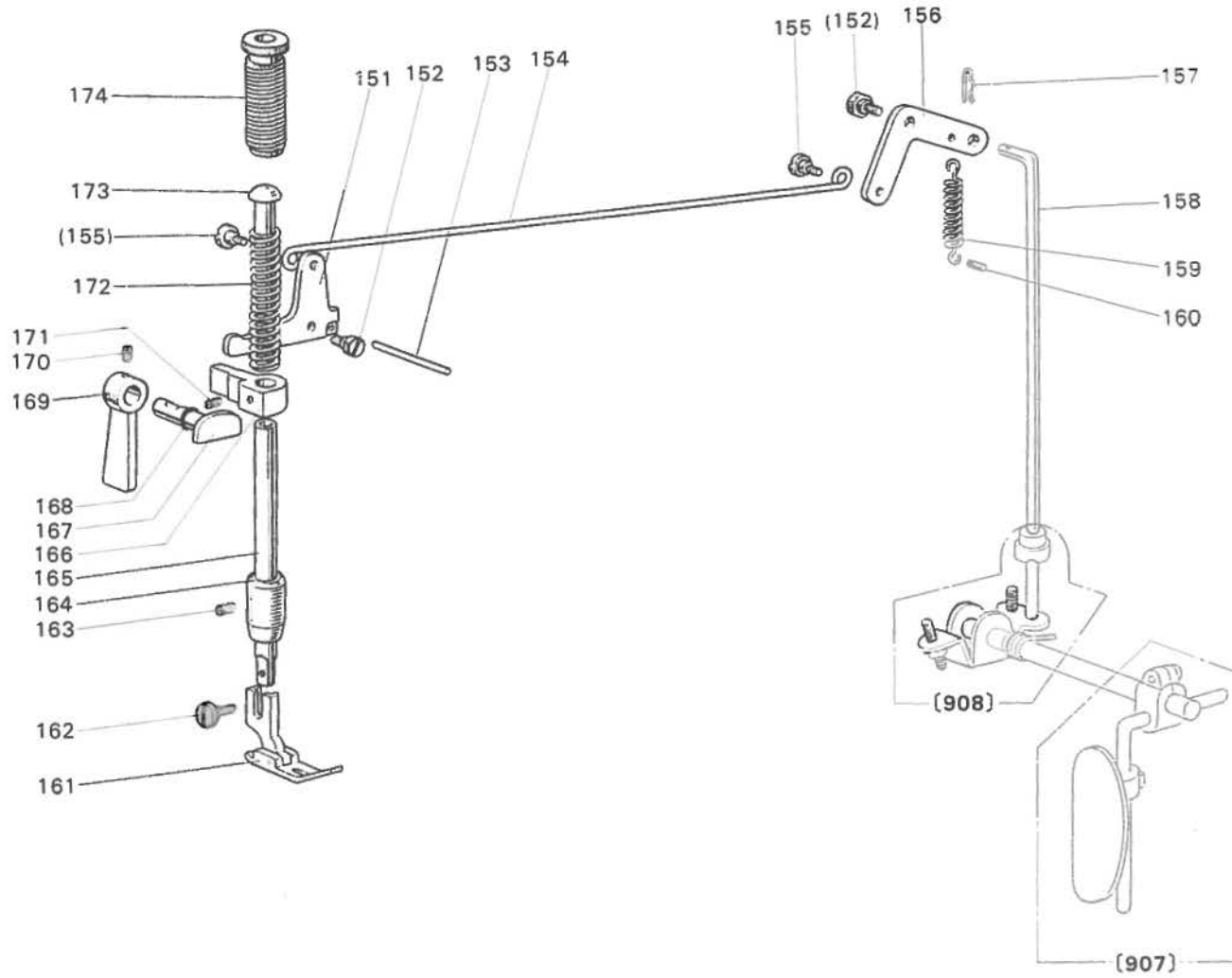

押工関係

PRESSER FOOT MECHANISM

Fig. No	部品コード Parts No.	資材コード Ref No.	部 品 名	Description	使用 個数 Amt. Req.	共通部品 Common Parts												
						DB-130E-10	DB-130E-10L	DB-130E-11	DB-130E-12	DB-130E-127	DB-130E-13	DB-130E-22	DB-130-10	DB-130-11	DB-130-12			
151	MF 70A0 950	W481457H01	押エ上ケレバー (左)	Knee lifter lever (left)	1	○	○	○	○	○	○	○	○	○	○	○	○	○
152	M9 1503 031	W481459H01	段付キボルト (押エ上ケレバー)	Bolt (for Fig. 151)	2	○	○	○	○	○	○	○	○	○	○	○	○	
153	M9 0314 060	W481434H01	ヒン (押エ上ケレバー)3.×40	Tension releasing pin	1	○	○	○	○	○	○	○	○	○	○	○	○	
154	MF 70A0 738	W481477H01	引 棒 (押エ上ゲ)	Knee lifter rod	1	○	○	○	○	○	○	○	○	○	○	○	○	
155	M9 1219 015	W481460H01	段付平ネジ 3 16(28)×6.7	Screw (for Fig. 154) 3 16(28)×6.7	2	○	○	○	○	○	○	○	○	○	○	○	○	
156	MF 70A1 950	W481458H01	押上ケレバー (右)	Knee lifter lever (right)	1	○	○	○	○	○	○	○	○	○	○	○	○	
157	M9 0102 062	P 587009X01	スナップヒン (突上ゲ棒)	Snap pin (for Fig. 158)	1	○	○	○	○	○	○	○	○	○	○	○	○	
158	MF 70A0 511	W481456H01	操 作 棒 (突上ゲ棒)	Knee lifter rod connecting rod	1	○	○	○	○	○	○	○	○	○	○	○	○	
159	MF 70A0 571	W481478H01	ツル巻バネ (押上ケレバー)	Spring (for Fig. 156)	1	○	○	○	○	○	○	○	○	○	○	○	○	
160	M9 0506 060	P 587011X01	溝付ヒン (BX形)5 /×24	pin (for Fig. 159)	1	○	○	○	○	○	○	○	○	○	○	○	○	
	MF 10A0 105	W450580G01	押 エ (標準)	Presser foot	1	○	○	○	○	○	○	○	○	○	○	○	○	
	MF 71D0 105	P 974005X01	押 エ (薄物L)	Presser foot	1	○	○	○	○	○	○	○	○	○	○	○	○	
161	MF 21D0 105	W472730G01	押 エ (薄物)	Presser foot	1	○	○	○	○	○	○	○	○	○	○	○	○	
	MF 12B0 105	W331472G01	押 エ (厚物)	Presser foot	1	○	○	○	○	○	○	○	○	○	○	○	○	
	MF 23C0 105	W452333G01	押 エ (極厚)	Presser foot	1	○	○	○	○	○	○	○	○	○	○	○	○	
162	M9 0922 002	W464016H01	平 ネジ 9 64(40)×8	Screw (for Fig. 16) 9 64(40)×8	1	○	○	○	○	○	○	○	○	○	○	○	○	
163	M9 1102 001	W500489H01	頭ナシ止メネジ 11 64(40)×2.7	Set screw (for Fig. 164) 11 64(40)×2.7	1	○	○	○	○	○	○	○	○	○	○	○	○	
164	MF 10A0 267	W502081H01	メ タ ル (押エ棒)	Presser bar bushing	1	○	○	○	○	○	○	○	○	○	○	○	○	
165	MF 10A0 262	W502079H01	押 エ 棒	Presser bar	1	○	○	○	○	○	○	○	○	○	○	○	○	
	MF 11D0 262	W502943H01	押 エ 棒 (薄物)	Presser bar	1	○	○	○	○	○	○	○	○	○	○	○	○	
166	MF 70A0 265	W481461H01	押 エ 棒 タキ	Presser bar lifting bracket	1	○	○	○	○	○	○	○	○	○	○	○	○	
167	MF 70A0 253	W481455H01	押 エ 上ゲカム	Presser bar lifting cam	1	○	○	○	○	○	○	○	○	○	○	○	○	
168	M9 0800 086	P 625001X01	オイルシール (押エ上ゲカム)	Oilseal (for Fig. 167)	1	○	○	○	○	○	○	○	○	○	○	○	○	
169	MF 70A0 252	W481454H01	押 エ 上ゲ	Presser bar lifter	1	○	○	○	○	○	○	○	○	○	○	○	○	
170	M9 1108 001	B 503846H01	頭ナシ止メネジ 11 64(40)×5.5	Set screw (for Fig. 169) 11 64(40)×5.5	1	○	○	○	○	○	○	○	○	○	○	○	○	
171	M9 1508 001	B 509088H01	頭ナシ止メネジ 15 64(28)×8	Set screw (for Fig. 165) 15 64(28)×8	1	○	○	○	○	○	○	○	○	○	○	○	○	
172	MF 10A0 259	W502444H01	押 エ ハネ (標準)	Presser spring	1	○	○	○	○	○	○	○	○	○	○	○	○	
	MF 12B0 259	W502441H01	押 エ バネ (厚物)	Presser spring	1	○	○	○	○	○	○	○	○	○	○	○	○	
173	MF 20A0 703	W475491H01	案内 棒 (押エバネ)	Presser bar guide	1	○	○	○	○	○	○	○	○	○	○	○	○	
174	M9 3209 035	W481436H01	ソ マ ミ ネジ (押工調節 1 2(28)×6.3	Presser regulating thumb screw	1	○	○	○	○	○	○	○	○	○	○	○	○	

水平送り軸・上下送り軸関係

FEED ROCK SHAFT & FEED LIFTING SHAFT MECHANISM

DB-130E-10

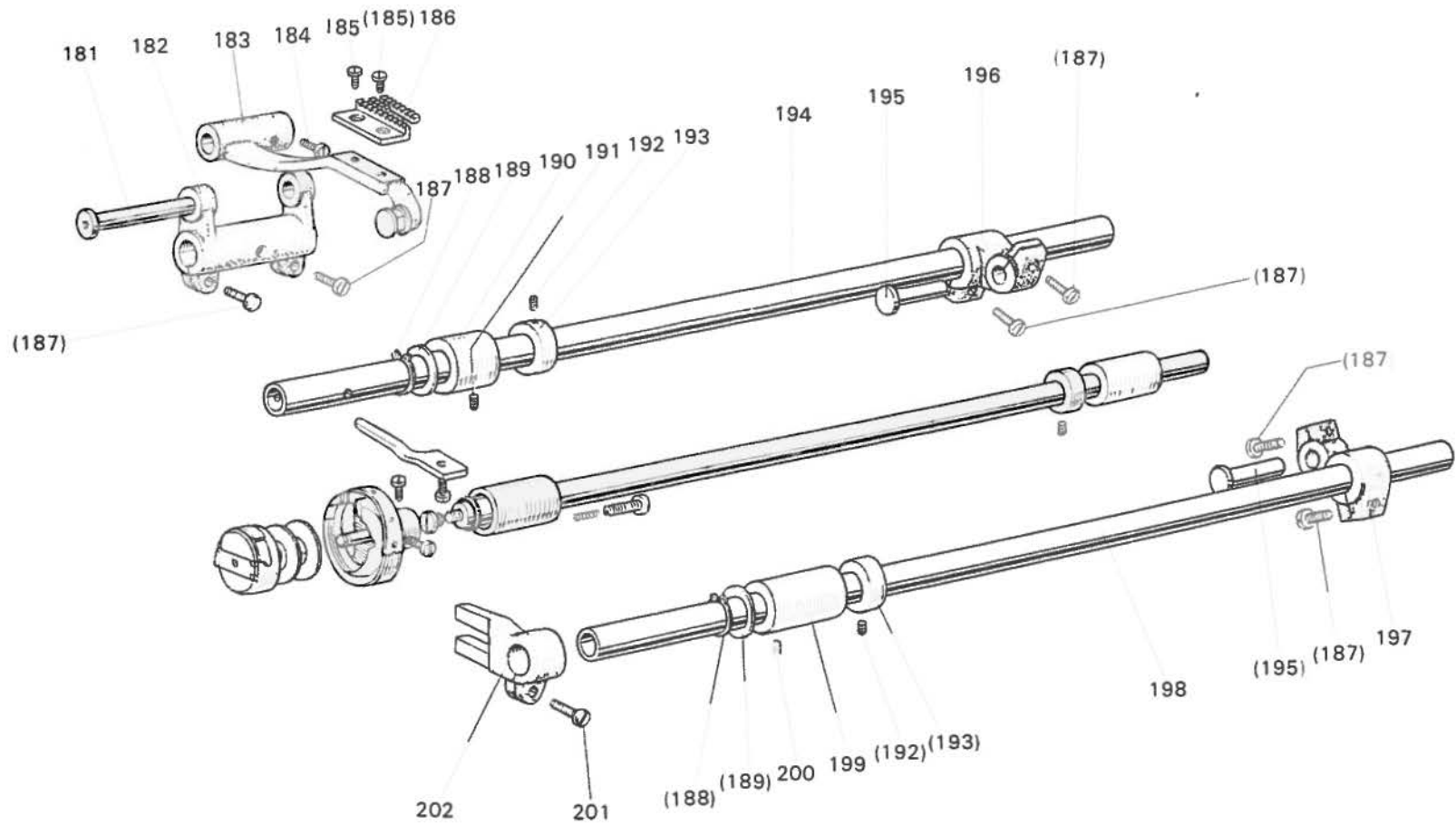

水平送り軸・上下送り軸関係

FEED ROCK SHAFT & FEED LIFTING SHAFT MECHANISM

Fig. No	部品コード Parts No.	資材コード Ref. No.	部品名	Description	使用 個数 Amt Req	共通部品 Common Parts												
						DB-130E 10	DB-130E 10L	DB-130E 11	DB-130E 12	DB-130E 127	DB-130E 13	DB-130E 22	DB-130-10	DB-130-11	DB-130-12			
181	MF 70AO 283	W481422H01	軸 (送り台支エ)	Feed bar shaft	1													
182	MF 70AO 278	W481421H01	送り腕 (水平左)	Feed rock shaft crank (left)	1													
183	MF 70AO 281	W481466H01	送り台	Feed bar	1													
184	M9 1103 002	B 509062H01	平ネジ 11 64(40)×5	Set screw (for Fig 183) 11 64(40)×5	1													
185	M9 0806 002	B 508857H01	平ネジ 1 8(44)×6	Screw (for Fig 186) 1 8(44)×6	2													
	MF 10AO 104	W462604H01	送り標準3枚歯	Feed dog	1													
186	MF 24DO 104	W454802H01	送り薄物L4枚歯	Feed dog	1													
	MF 11DO 104	W457555H01	送り薄物4枚歯	Feed dog	1													
187	M9 1203 002	B 509178H01	平ネジ 3 16(28)×15	Screw (for Fig 182) 3 16(28)×15	6													
188	M9 0315 065	S 591411H15	C形止メ輪M5	C-type stop ring (for Fig 194 198)	2													
189	M9 3001 052	W502467H01	特殊座金	Slide washer (for Fig 194 198)	2													
190	MF 70AO 286	W481663H01	水平送り軸メタル (左)	Feed rock shaft bushing (left)	1													
191	M9 1503 001	B 508971H01	頭ナシ止メネジ 15 64(28)×4.5	Set screw (for Fig 190) 15 64(28)×4.5	1													
192	M9 1602 001	W500036H01	頭ナシ止メネジ 1 4(40)×4	Set screw (for Fig 193) 1 4(40)×4	4													
193	MF 70AO 352	W476422H01	カラ (水平送り軸)	Collar (for Fig 194 198)	2													
194	MF 70AO 491	W481420H01	水平送り軸	Feed rock shaft	1													
195	M9 0904 060	W502476H02	ピン 9.53×21	Set pin for feed forked connecting rod	2													
196	MF 70AO 279	W481473H01	送り腕 (水平右)	Feed rock shaft crank (right)	1													
	MF 26BO 279	W447855H01	送り腕 (水平右) 7mm	Feed rock shaft crank (right) 7mm feed	1													
197	MF 70AO 277	W481472H01	上下送り腕 (右)	Feed lifting rock shaft crank (right)	1													
198	MF 70AO 460	W481673H01	上下送り軸	Feed lifting rock shaft	1													
199	MF 70A1 286	W481475H01	上下送り軸メタル (左)	Feed lifting rock shaft bushing (left)	1													
200	M9 1516 001	W500006H01	頭ナシ止メネジ 15 64(28)×15	Set screw (for Fig.199) 15 64(28)×15	1													
201	M9 1112 002	B 501889H01	平ネジ 11 64(40)×12	Screw (for Fig.202) 11 64(40)×12	1													
202	MF 70AO 276	W481471H01	上下送り軸フタ又	Feed lifting rock shaft forked crank	1													



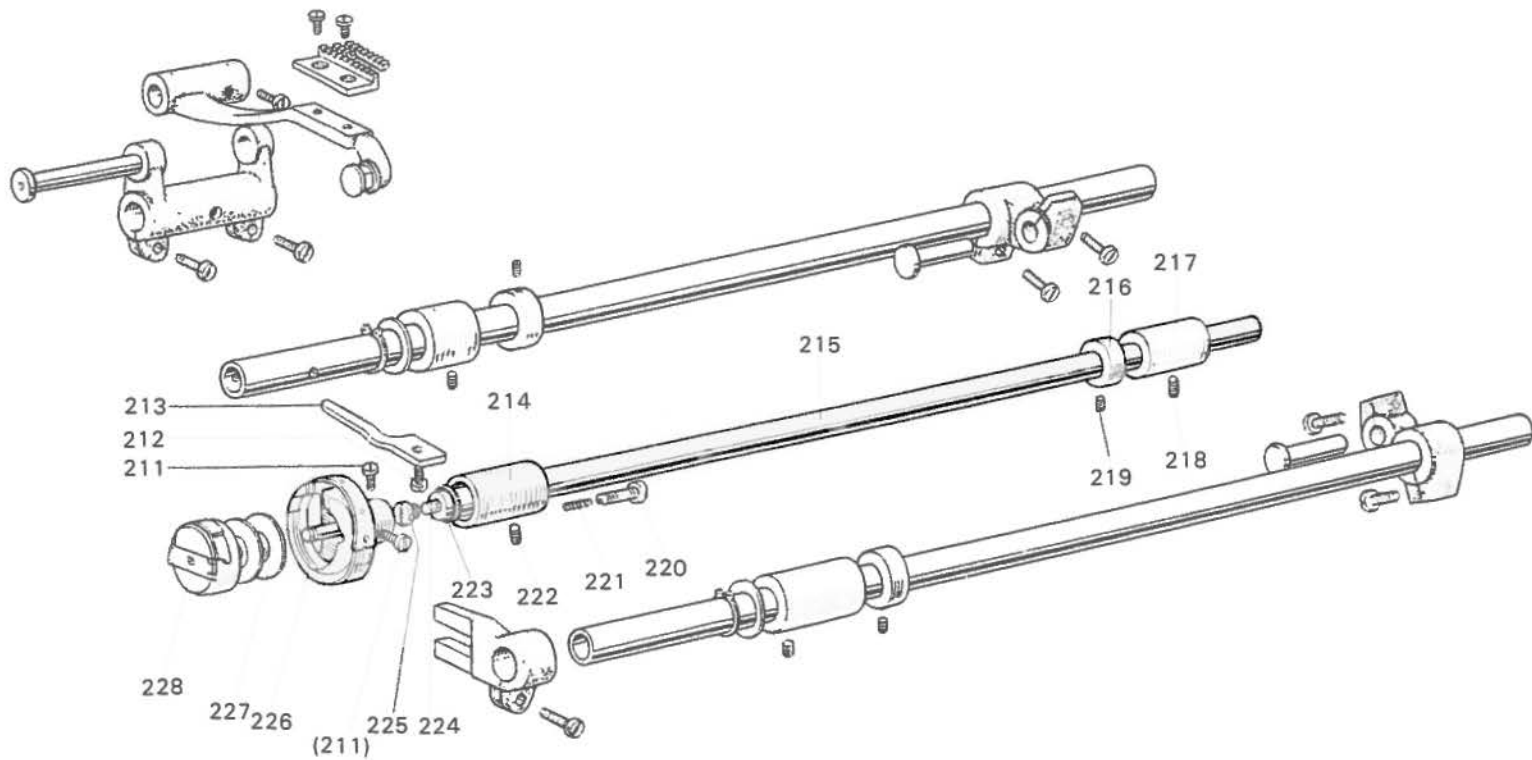

下軸・カマ関係

ROTATING HOOK SHAFT & ROTATING HOOK MECHANISM

Fig. No.	部品コード Parts No.	資材コード Ref. No.	部 品 名	Description	使用 個数 Amt. Req.	共通部品 Common Parts											
						DB-130E-10	DB-130E-10L	DB-130E-11	DB-130E-12	DB-130E-12-7	DB-130E-13	DB-130E-22	DB-130-10	DB-130-11	DB-130-12		
211	M9 1101 002	W500194H01	平ネシ 11/64(40)×14	Set screw (for Fig.226) 11/64(40)×14	2	○	○	○	○	○	○	○	○	○	○	○	○
212	M9 1118 002	B 509061H01	平ネシ 11/64(40)×10	Screw (for Fig.213) 11/64(40)×10	1	○	○	○	○	○	○	○	○	○	○	○	○
213	MF 10AO 229	W462633H01	内カマ止メ(標準)	Rotating hook positioner	1	○	○	○	○	○	○	○	○	○	○	○	○
	MF 17B0 229	W470246H01	内カマ止メ(極厚)	Rotating hook positioner	1	○	○	○	○	○	○	○	○	○	○	○	○
	MF 20AO 229	W468837H01	内カマ止メ(2倍カマ)	Rotating hook positioner	1	○	○	○	○	○	○	○	○	○	○	○	○
214	MF 70AO 451	W481463H01	下軸メケル(左)	Rotating hook shaft bushing (left)	1	○	○	○	○	○	○	○	○	○	○	○	○
215	MF 70AO 450	W481462H01	下軸	Rotating hook shaft	1	○	○	○	○	○	○	○	○	○	○	○	○
	MF 74B0 450	W461683H01	下軸(2倍ガマ)	Rotating hook shaft	1	○	○	○	○	○	○	○	○	○	○	○	○
216	MF 10AO 352	B 422844H01	カラ(下軸)	Collar (for Fig. 215)	1	○	○	○	○	○	○	○	○	○	○	○	○
217	MF 70AO 452	W481419H01	下軸メケル(右)	Rotating hook shaft bushing (right)	1	○	○	○	○	○	○	○	○	○	○	○	○
218	M9 1516 001	W500006H01	頭ナン止メネシ 15/64(28)×15	Set screw (for Fig.217) 15/64(28)×15	1	○	○	○	○	○	○	○	○	○	○	○	○
219	M9 1503 001	B 508971H01	頭ナン止メネシ 15/64(28)×4.5	Set screw (for Fig.216) 15/64(28)×4.5	2	○	○	○	○	○	○	○	○	○	○	○	○
220	M9 0909 030	W481464H01	特殊ネシ(油調節) 9/64(40)×15	Oil adjusting screw 9/64(40)×15	1	○	○	○	○	○	○	○	○	○	○	○	○
221	MF 70A1 572	W481664H01	ツル巻バネ(油調節)	Spring (for Fig.220)	1	○	○	○	○	○	○	○	○	○	○	○	○
222	M9 1513 001	B 509060H01	頭ナン止メネシ 15/64(28)×11	Set screw (for Fig 214) 15/64(28)×11	1	○	○	○	○	○	○	○	○	○	○	○	○
223	M9 0802 086	W468257H01	オイルシール(下軸)	Oil seal for rotating hook shaft	1	○	○	○	○	○	○	○	○	○	○	○	○
224	MF 10E3 148	W500231H01	油紐(下軸)	Oil cotton braid (for Fig.215)	1	○	○	○	○	○	○	○	○	○	○	○	○
225	M9 1251 030	W500190H01	特殊ネシ 3/16(32)×6.7	Special screw (for Fig.215) 3/16(32)×6.7	1	○	○	○	○	○	○	○	○	○	○	○	○
226	MF 10AO 120	W218864H01	カマ(HSL-BSJ/KHS-12SM)	Rotating hook	1	○	○	○	○	○	○	○	○	○	○	○	○
	MF 22B0 120	P 975010X01	カマ(HSL-AN/KHS-12R)	Rotating hook	1	○	○	○	○	○	○	○	○	○	○	○	○
227	MF 25B0 120	P 975005X02	カマ(HSM A/KHS-20RM2)	Rotating hook	1	○	○	○	○	○	○	○	○	○	○	○	○
	MF 10AO 123	W462632H01	ホビン(標準)	Bobbin	1	○	○	○	○	○	○	○	○	○	○	○	○
	MF 41D0 123	W466807H01	ホビン(薄物L)	Bobbin	1	○	○	○	○	○	○	○	○	○	○	○	○
228	MF 25B0 123	W470215H01	ホビン(2倍カマ)	Bobbin	1	○	○	○	○	○	○	○	○	○	○	○	○
	MF 10E0 125	W461742G01	ホビンケース	Bobbin case	1	○	○	○	○	○	○	○	○	○	○	○	○
	MF 25E0 125	W473391H01	ホビンケース(2倍カマ)	Bobbin case	1	○	○	○	○	○	○	○	○	○	○	○	○

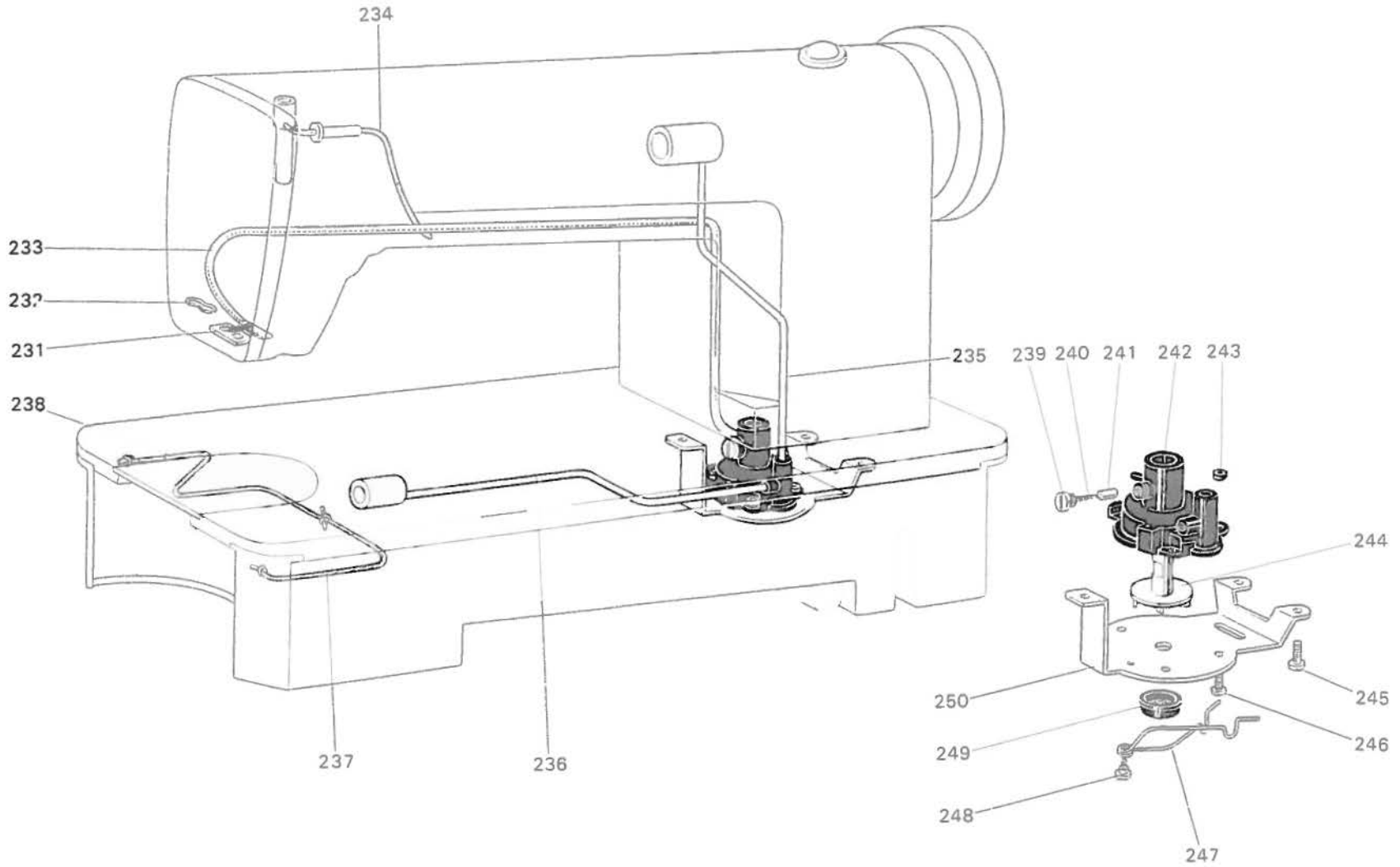

給油関係

LUBRICATION MECHANISM

Fig No	部品コード Parts No.	資材コード Ref. No.	部 品 名	Description	使用 個数 Amt Req	共通部品 Common Parts											
						DB-130E-10	DB-130E-10L	DB-130E-11	DB-130E-12	DB-130E-12-7	DB-130E-13	DB-130E-22	DB-130-10	DB-130-11	DB-130-12		
231	MF 70E0 740	W482321G01	フェルト(組)	Felt pouch (return oil filter)	1	○	○	○	○	○	○	○	○	○	○	○	○
232	MF 70A0 605	W479329H01	フェルト押エ	Felt pouch supporter	1	○	○	○	○	○	○	○	○	○	○	○	○
233	MF 70A0 731	W482323H01	ビニールパイプ	Oil return pipe	1	○	○	○	○	○	○	○	○	○	○	○	○
234	MF 10E2 148	W444138H01	油 紐 (針標メタル上)2.5φ×240	Oil cotton braid (for Fig.904,108 oiling)	1	○	○	○	○	○	○	○	○	○	○	○	○
235	MF 70A0 688	W341645H01	パイプ(上軸)	Oil pipe for arm shaft	1	○	○	○	○	○	○	○	○	○	○	○	○
236	MF 70A1 688	W341646H01	パイプ(下軸)	Oil pipe for rotating hook shaft	1	○	○	○	○	○	○	○	○	○	○	○	○
237	MF 10E2 148	W444138H01	油 紐 (上下送り機) 2.5φ×240	Oil cotton braid for feed lifting mecha	1	○	○	○	○	○	○	○	○	○	○	○	○
238	MF 10E2 148	W462982H01	油 紐 (水平送り機) 2.5φ×330	Oil cotton braid for feed rock mecha	1	○	○	○	○	○	○	○	○	○	○	○	○
239	M9 1601 002	W501102H01	平 ネジ 1/4(40)×5	Oil adjusting screw 1/4(40)×5	1	○	○	○	○	○	○	○	○	○	○	○	○
240	MF 70A2 572	W481441H01	ツル巻バネ(プランジャー)	Spring (for Fig.241)	1	○	○	○	○	○	○	○	○	○	○	○	○
241	MF 70A0 753	W481440H01	プランジャー(オイルポンプ)	Plunger for oil pump	1	○	○	○	○	○	○	○	○	○	○	○	○
242	MF 70A0 783	W341644H01	ポンプケース	Oil pump (body)	1	○	○	○	○	○	○	○	○	○	○	○	○
243	M9 1002 045	S 541121H02	ナット M4×3.2	Nut (for Fig.246) M4×3.2	3	○	○	○	○	○	○	○	○	○	○	○	○
244	MF 70A0 685	W481435H01	羽根車	Oil pump impeller	1	○	○	○	○	○	○	○	○	○	○	○	○
245	M9 1103 004	W467868H01	ブラマイネジ 11/64(40)×13	Screw (for Fig 250) 11/64(40)×13	3	○	○	○	○	○	○	○	○	○	○	○	○
246	M9 0410 037	S 512131H08	Pナベネジ M4×8	Screw (for Fig 242) M4×10	3	○	○	○	○	○	○	○	○	○	○	○	○
247	MF 70A1 605	W481442H01	バネ(フィルタストップ)	Oil pump screen set spring	1	○	○	○	○	○	○	○	○	○	○	○	○
248	M9 1219 015	W481460H01	設付ネジ 3/16(28)×6.7	Screw (for Fig 247) 3/16(28)×6.7	1	○	○	○	○	○	○	○	○	○	○	○	○
249	MF 70E0 337	W481445G01	フィルタ(組)	Oil pump screen	1	○	○	○	○	○	○	○	○	○	○	○	○
250	MF 70A0 601	W341680H01	ポンプ取付板	Oil pump fitting plate	1	○	○	○	○	○	○	○	○	○	○	○	○

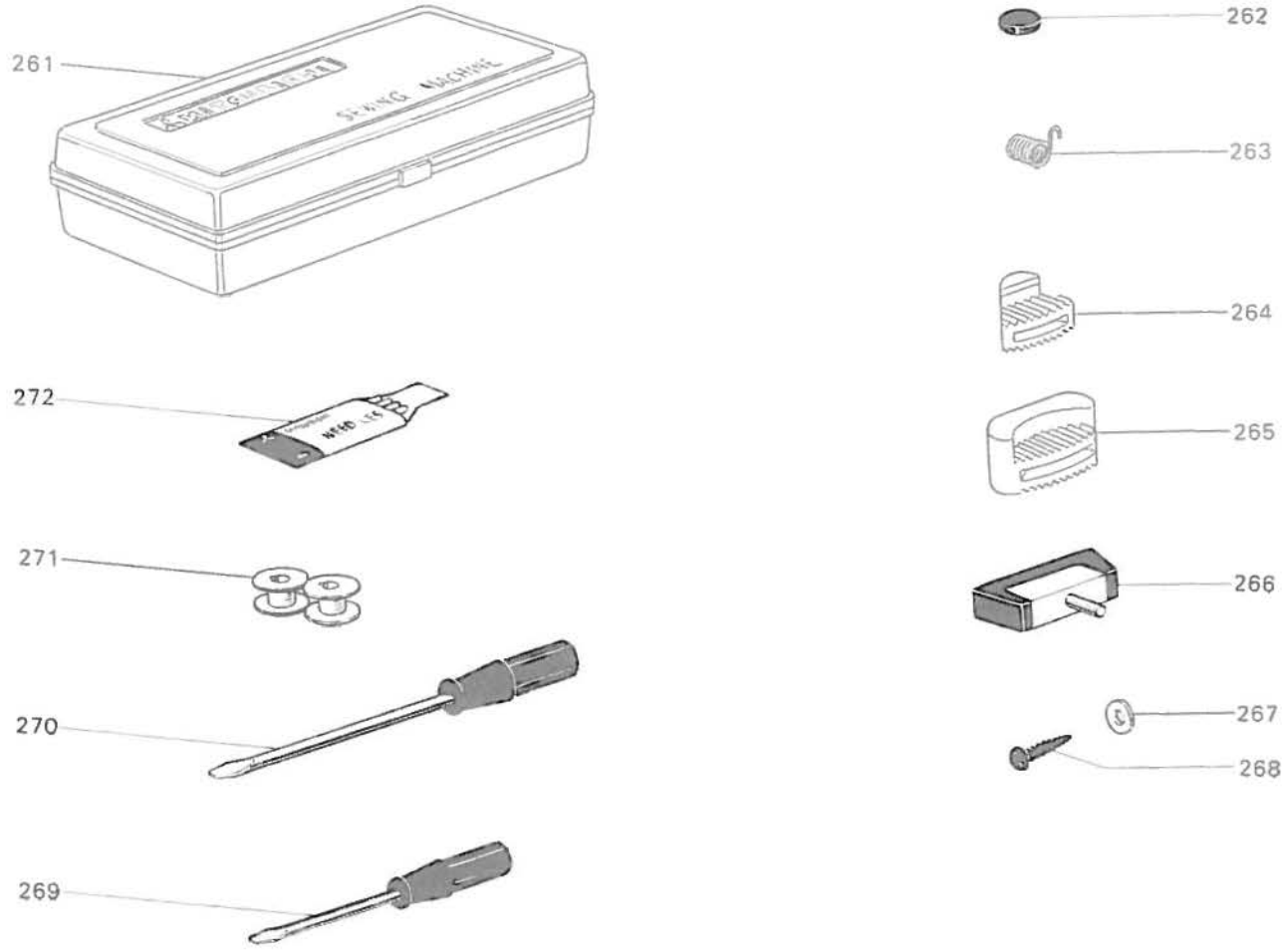

付属品箱関係

ACCESSORY BOX & ACCESSORIES

Fig. No	部品コード Parts No	資材コード Ref. No.	部 品 名	Description	使用 個数 Amt Req	#通部品 Common Parts													
						DB-130E-10	DB-130E-10L	DB-130E-11	DB-130E-12	DB-130E-127	DB-130E-13	DB-130E-22	DB-130-10	DB-130-11	DB-130-12				
261	MF 60AO 749	P 833000X01	付 属 品 箱	Accessory box	1														
262	M9 0701 099	P 463000X01	OP-S 磁 石	Magnet block for oil reservoir	1														
	MF 10AO 187	W475488H01	糸 取 リ バ ネ	Thread take-up spring	1														
263	MF 12BO 187	W461748H01	糸 取 リ バ ネ (厚物)	Thread take-up spring	1														
	MF 71DO 187	W481632H01	糸 取 リ バ ネ (薄物L)	Thread take-up spring	1														
264	MF 70A1 419	W476426H02	防 振 コ ム (小)	Vibration preventing rubber (small)	2														
265	MF 70AO 419	W476425H02	防 振 コ ム (大)	Vibration preventing rubber (large)	2														
266	MF 70EO 418	W481678G02	ゴ ム ヒ ン ジ (組)	Table hinge with rubber cushion	2														
267	M9 0608 050	S 562131H04	座 金 6	Washer for bobbin winder	2														
268	M9 0401 041	S 519132H01	丸 木 ネ シ 4.5×20	Screw for bobbin winder	2														
269	MB 02A1 608	P 842002X01	ネ シ 回 シ (小)	Screw driver (small)	1														
270	MB 02AO 608	P 842003X01	ネ シ 回 シ (中)	Screw driver (middle)	1														
	MF 10AO 123	W462632H01	ボ ビ ン	Bobbin	4														
271	MF 25BO 123	W470215H01	ボ ビ ン (2倍カマ)	Bobbin	4														
	MF 41DO 123	W466807H01	ボ ビ ン (薄物L)	Bobbin	4														
	MF 70AO 128	S 970010H01	ミ シ ン 針 DBX1-2-14	Needle DBX1-2-14	4														
	MF 71DO 128	S 970010H03	ミ シ ン 針 DBX1-2-11	Needle DBX1-2-11	4														
272	MF 21DO 128	S 970001H01	ミ シ ン 針 DAX1 #11	Needle DAX1 #11	4														
	MF 72BO 128	S 970010H02	ミ シ ン 針 DBX1-2-21	Needle DBX1-2-21	4														
	MF 23CO 128	S 970002H04	ミ シ ン 針 DBX1 #23	Needle DBX1 #23	4														

DB-130E-10

油槽・ソノ他付属品関係  
OIL RESERVOIR & OTHER ACCESSORIES

DB-130E-10

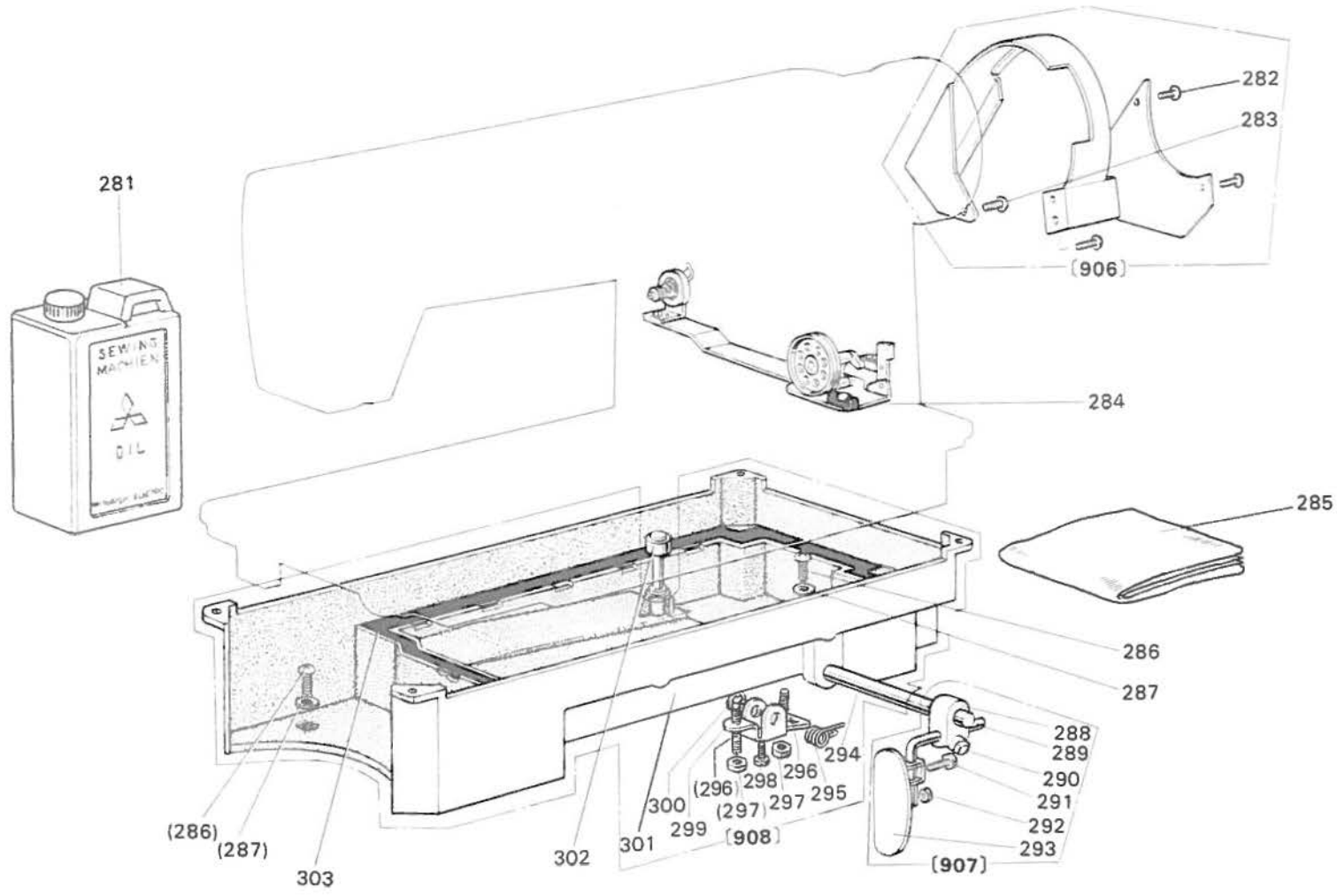

油槽・ソノ他付属品関係

OIL RESERVOIR & OTHER ACCESSORIES

Fig. No.	部品コード Parts No.	資材コード Ref. No.	部 品 名	Description	使用 個数 Amt Req.	共通部品 Common Parts												
						DB-130E-10	DB-130E-10L	DB-130E-11	DB-130E-12	DB-130E-12-7	DB-130E-13	DB-130E-22	DB-130-10	DB-130-11	DB-130-12			
281	MF 10E0 149	W227466H01	油 缶	Oil can	1	○	○	○	○	○	○	○	○	○	○	○	○	○
282	M9 1101 004	W466810H01	フ ラ マ イ ネ シ 11 64(40)×8	Screw (for Fig.906) 11 64(40)×8	3	○	○	○	○	○	○	○	○	○	○	○	○	
283	M9 1103 004	W467868H02	フ ラ マ イ ネ シ 11 64(40)×13	Screw (for Fig 906) 11 64(40)×13	3	○	○	○	○	○	○	○	○	○	○	○	○	
906	MF 20E0 776	W338204G01	ヘルトカバー(組) (≒BE-2)	Belt cover complete (BE-2)	1	○	○	○	○	○	○	○	○	○	○	○	○	
	MF 25E0 776	W339679G01	ヘルトカバー(組) (≒BE-11)	Belt cover complete (BE-11)	1	○	○	○	○	○	○	○	○	○	○	○	○	
284	MF 20E0 190	P 992002X01	糸 巻 仕 掛 (組)	Bobbin winder complete	1	○	○	○	○	○	○	○	○	○	○	○	○	
	MF 25E0 190	P 992008X01	糸 巻 仕 掛 (組) (2倍ガマ)	Bobbin winder complete	1	○	○	○	○	○	○	○	○	○	○	○	○	
285	MF 60A0 734	W220627H02	ビニールカバー	Vinyl covor	1	○	○	○	○	○	○	○	○	○	○	○	○	
286	M9 2001 004	W478196H01	フ ラ マ イ ネ シ 5 16(28)×10.0	Oil drain screw 5 16(28)×10.0	2	○	○	○	○	○	○	○	○	○	○	○	○	
287	M9 7001 052	W470200H01	特 殊 応 全	Washer (for Fig 286)	2	○	○	○	○	○	○	○	○	○	○	○	○	
288	MF 20A0 784	W447074H01	膝 接 手	Knee plate bar bracket	1	○	○	○	○	○	○	○	○	○	○	○	○	
289	MF 20A0 728	W449371H01	操 作 棒	Knee plate bar	1	○	○	○	○	○	○	○	○	○	○	○	○	
290	M9 2001 031	B 509174H01	角 頭 ホ ル ト 5 16(18)×13	Set screw (for Fig 288) 5 16(18)×13	2	○	○	○	○	○	○	○	○	○	○	○	○	
291	M9 2051 022	W469723H01	ナ ッ ト M8×16	Set screw (for Fig 293) M8×16	1	○	○	○	○	○	○	○	○	○	○	○	○	
292	M9 2071 045	W469724H01	ナ ッ ト M8×6 5	Nut (for Fig 291) M8	1	○	○	○	○	○	○	○	○	○	○	○	○	
293	MF 20A0 510	W325888H01	換 作 板	Knee plate	1	○	○	○	○	○	○	○	○	○	○	○	○	
907	MF 20E0 727	W227492G01	膝 上 ケ 仕 掛 (組)	Knee lifter complete	1	○	○	○	○	○	○	○	○	○	○	○	○	
294	MF 20A1 723	W478169H01	膝 上 ゲ 軸	Knee lifter rock shaft	1	○	○	○	○	○	○	○	○	○	○	○	○	
295	MF 20A1 729	W479331H01	ヒ ネ リ ハ ネ	Spring (for Fig.299)	1	○	○	○	○	○	○	○	○	○	○	○	○	
296	M9 1520 001	B 503980H01	頭 ナ シ 止 メ ネ シ 15 64(28)×28	Stopper screw (for Fig.907) 15 64(28)×28	2	○	○	○	○	○	○	○	○	○	○	○	○	
297	M9 1501 045	B 509260H01	ナ ッ ト 15 64(28)×3	Nut (for Fig.296) 15 64(28)	2	○	○	○	○	○	○	○	○	○	○	○	○	
298	M9 1502 002	W500509H01	平 ネ ジ 15 64(28)×12	Set screw (for Fig 299) 15 64(28)×12	1	○	○	○	○	○	○	○	○	○	○	○	○	
299	MF 20A1 724	W477606H01	膝 上 ケ 腕	Knee lifter crank	1	○	○	○	○	○	○	○	○	○	○	○	○	
300	M9 0509 065	S 592411H08	E 形 止 メ 輪 9	E-type stop ring	1	○	○	○	○	○	○	○	○	○	○	○	○	
301	MF 70A0 139	P 997000X02	油 槽	Oil reservoir	1	○	○	○	○	○	○	○	○	○	○	○	○	
908	MF 70E0 139	ZM00040	油 槽 (組)	Oil reservoir complete	1	○	○	○	○	○	○	○	○	○	○	○	○	
302	MF 70A0 578	W481685H01	膝 上 ケ ビ ン	Knee lifter lifting rod	1	○	○	○	○	○	○	○	○	○	○	○	○	
303	MF 20A2 691	W471440H02	ガ ス ケ ッ ト (小) (油槽)	Gasket for oil reservoir (small)	1	○	○	○	○	○	○	○	○	○	○	○	○	
	MF 20A3 691	W471441H02	ガ ス ケ ッ ト (大) (油槽)	Gasket for oil reservoir (large)	1	○	○	○	○	○	○	○	○	○	○	○	○	



