

Purchasing Dept
Copy

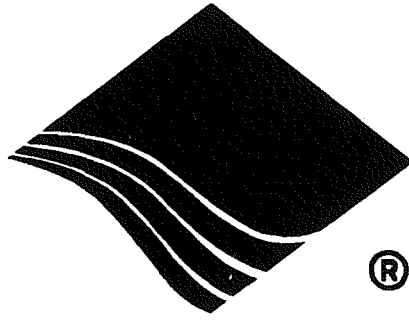

HIGHLEAD

GK600 SERIES

High-speed Stretch Sewing Machine

Instruction Manual
Parts Catalog

SHANGHAI HUIGONG NO.3 SEWING MACHINE FACTORY

From the library of: Superior Sewing Machine & Supply LLC

— INTRODUCTION —

Thank you very much for purchasing 600 Series machine.

This instruction manual describes daily routine maintenance and safety precautions to keep the machine in the best possible conditions.

Please study this manual very carefully before operating the machine.



CAUTION

OBSERVE THESE SAFETY PRECAUTIONS

Though Pegasus takes the utmost care to produce safe sewing machines and devices, operators should follow these basic safety rules.

- To prevent accidents, do not remove safety devices or parts while operating the machine.
- Do not leave tools or other unnecessary objects on the machine table while operating the machine.
- Before maintenance, adjusting, cleaning, threading or replacing the needle, and to prevent accidents, be sure the power is turned off. Check that the machine will not operate when the pedal is pressed.



NOTE

In case a crutch type motor is used, it will keep on rotating by inertia after turning off power supply

- ①. If the machine pedal ② is stepped on inadvertently, it is dangerous because the machine will move unexpectedly. Keep on stepping on the machine pedal ② until the machine comes to a stop after turning off power supply ①.

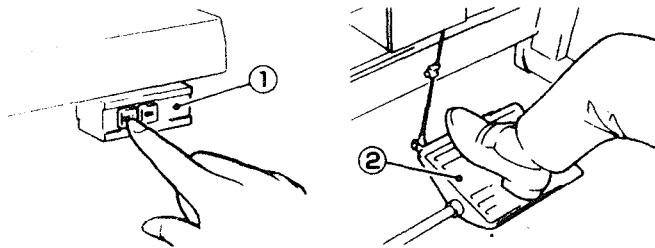

- Turn the power off before leaving the machine table.
- In the event of a power failure, be sure to turn the machine off.
- Check that the machine is securely grounded.

— CONTENTS —

■ **BEFORE OPERATING**

1. Lubrication	1
2. Manual lubrication	2
3. Filling the HR device with silicon oil	3
4. Threading	4
5. Threading diagram (2-needle、3-needle)	5

■ **TEST SEWING**

1. Adjusting the presser foot pressure	6
2. Adjusting the diff. feed ratio	7
3. Adjusting the stitch length	8
4. Adjusting the thread tension	9

■ **MAINTENANCE DURING USE**

1. Cleaning the machine	10
2. Replacing the needle	11
3. Checking the oil circulation	12
4. Checking and replacing the oil filter	13
5. Replacing the oil	14

■ **PARTS CATALOG**

.....	15-20
-------	-------

■ BEFORE OPERATING

Lubrication

After filling the oil pan, the oil surface should lie between (H) and (L) lines.

Add oil when the oil surface reaches or goes below (L).

Note : Use recommended oil (HIGH SPEED SEWING MACHINE OIL) (ISO VG22)

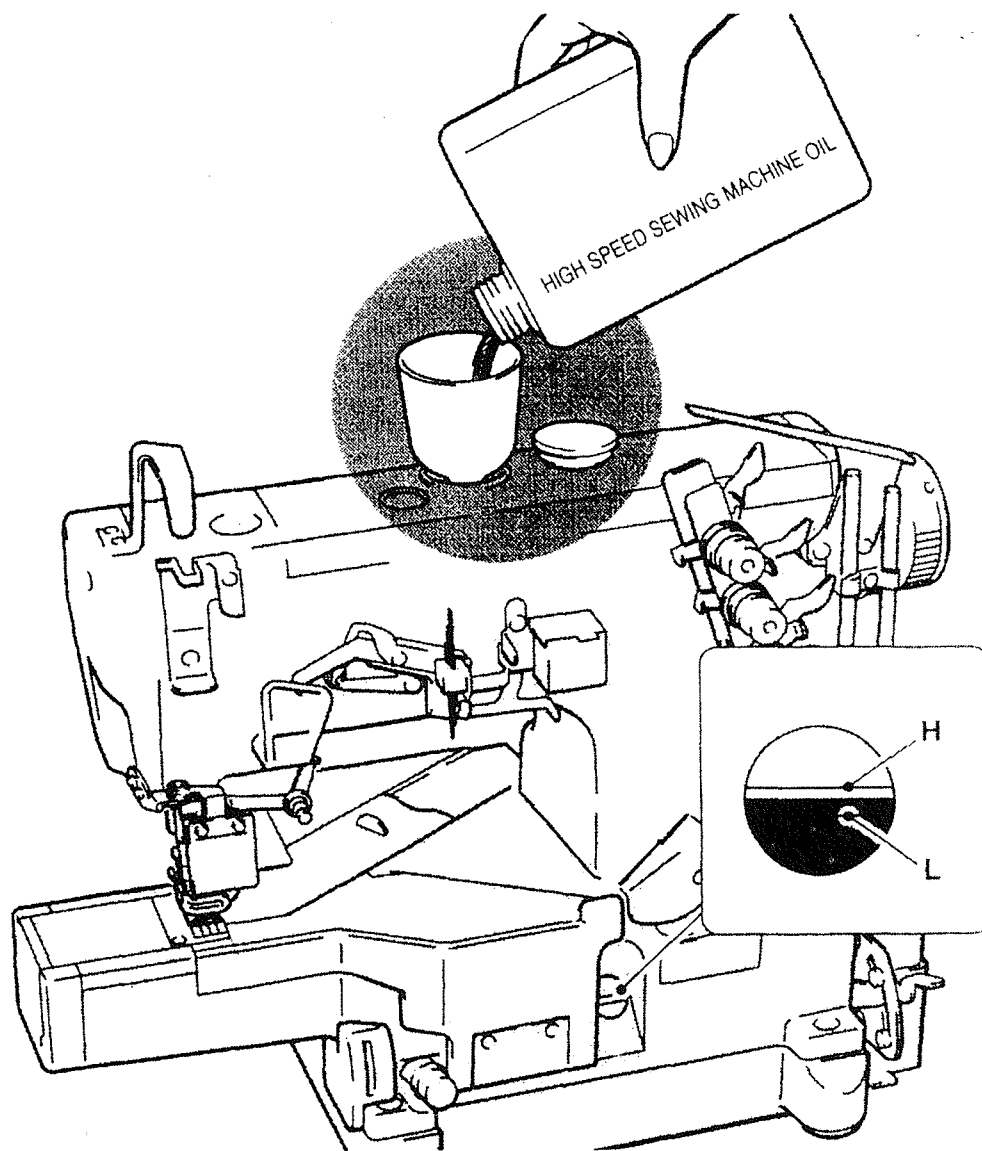

■ BEFORE OPERATING

Manual lubrication

Apply 2 or 3 drops of oil by hand when the machine is used for the first time or has been left unused for some time.

Note : Use recommended oil (HIGH SPEED SEWING MACHINE OIL) (ISO VG22)

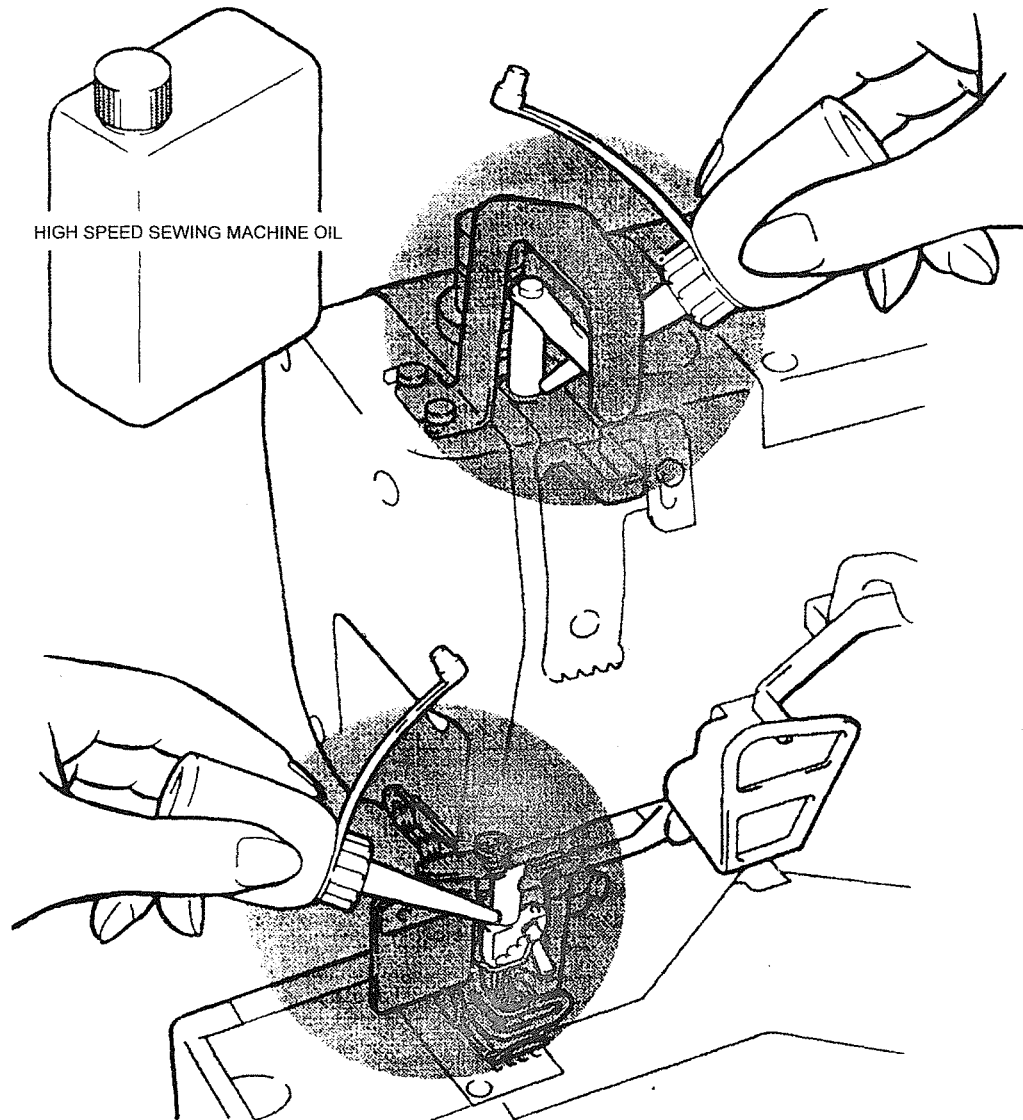

■ BEFORE OPERATING

Filling the HR device with silicon oil

Fill the HR device with oil before it is too low in order to prevent needle thread breakage and fabric damage.

Note : Use recommended silicon oil

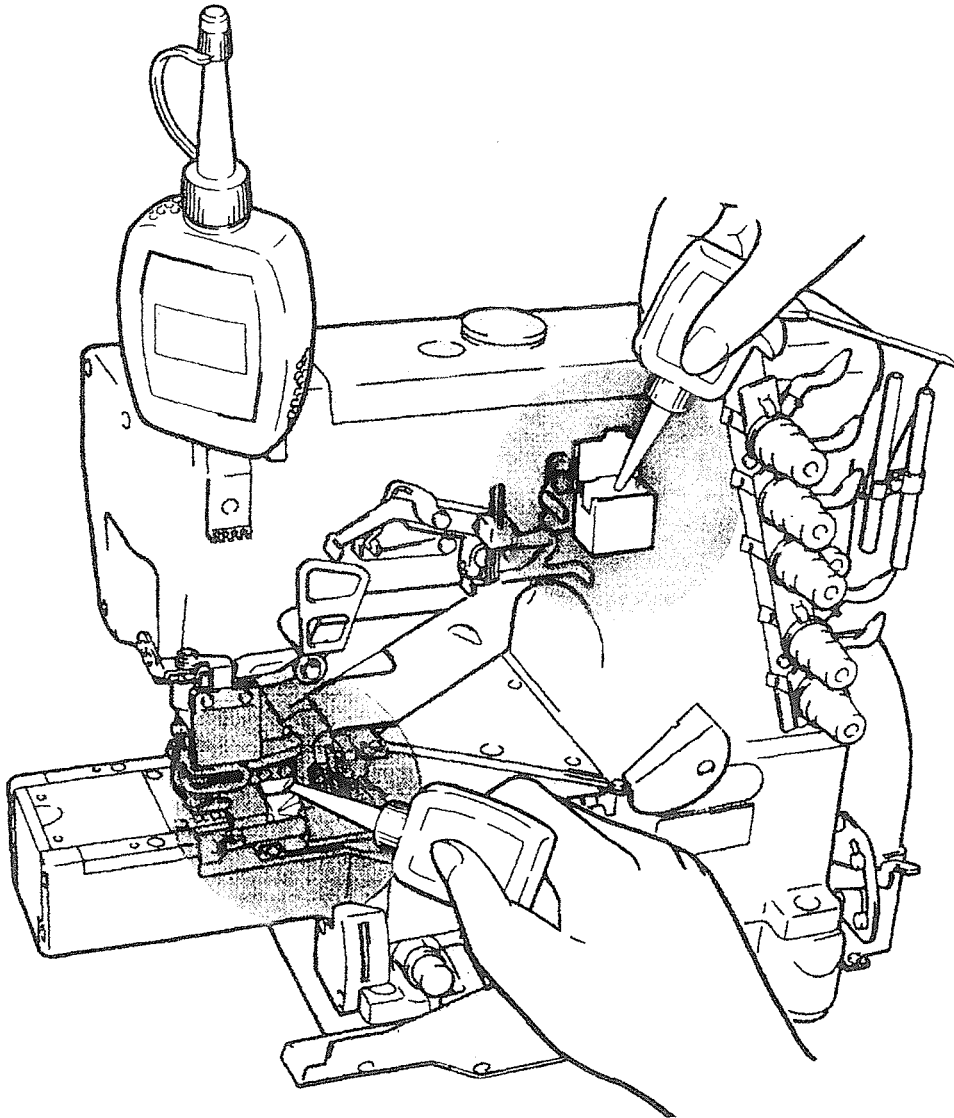

■ BEFORE OPERATING

Threading

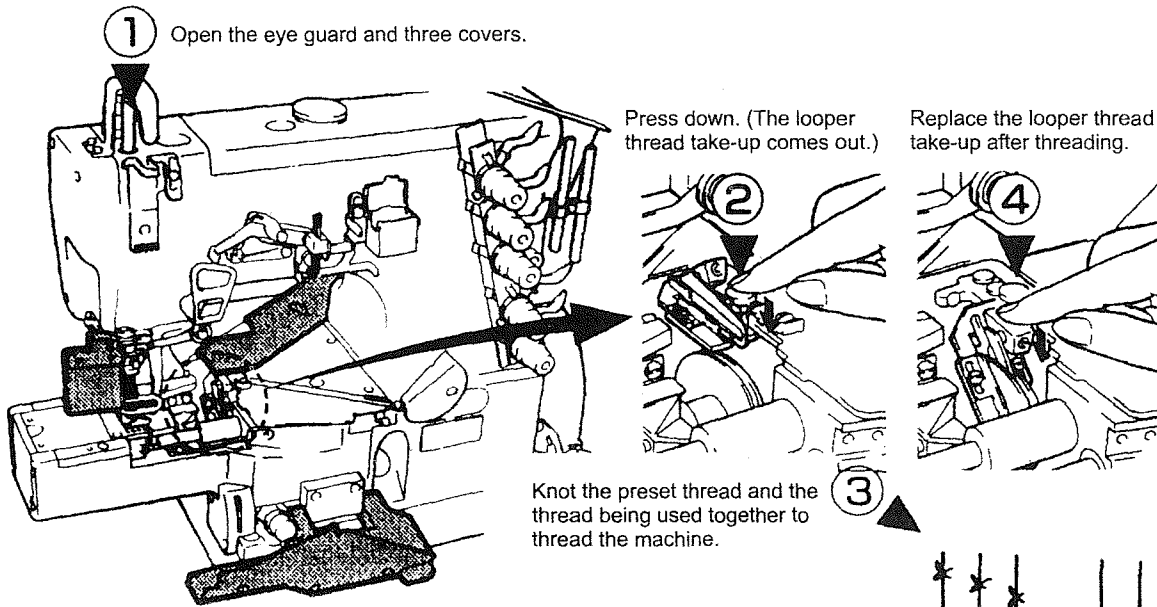

Needle thread

Tirm the knots off neatly before passing through the eye of the needle to tethread.

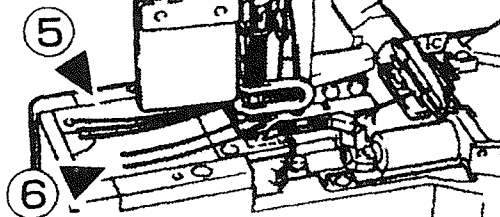

Looperthread, Top coverthread

Tirm the knots off neatly after passing through the eye of the looper.

Be sure to thread the machine correctly by referring to the threading diagram. (See P.5)

■ BEFORE OPERATING

Threading diagram (2-needle, 3-needle)

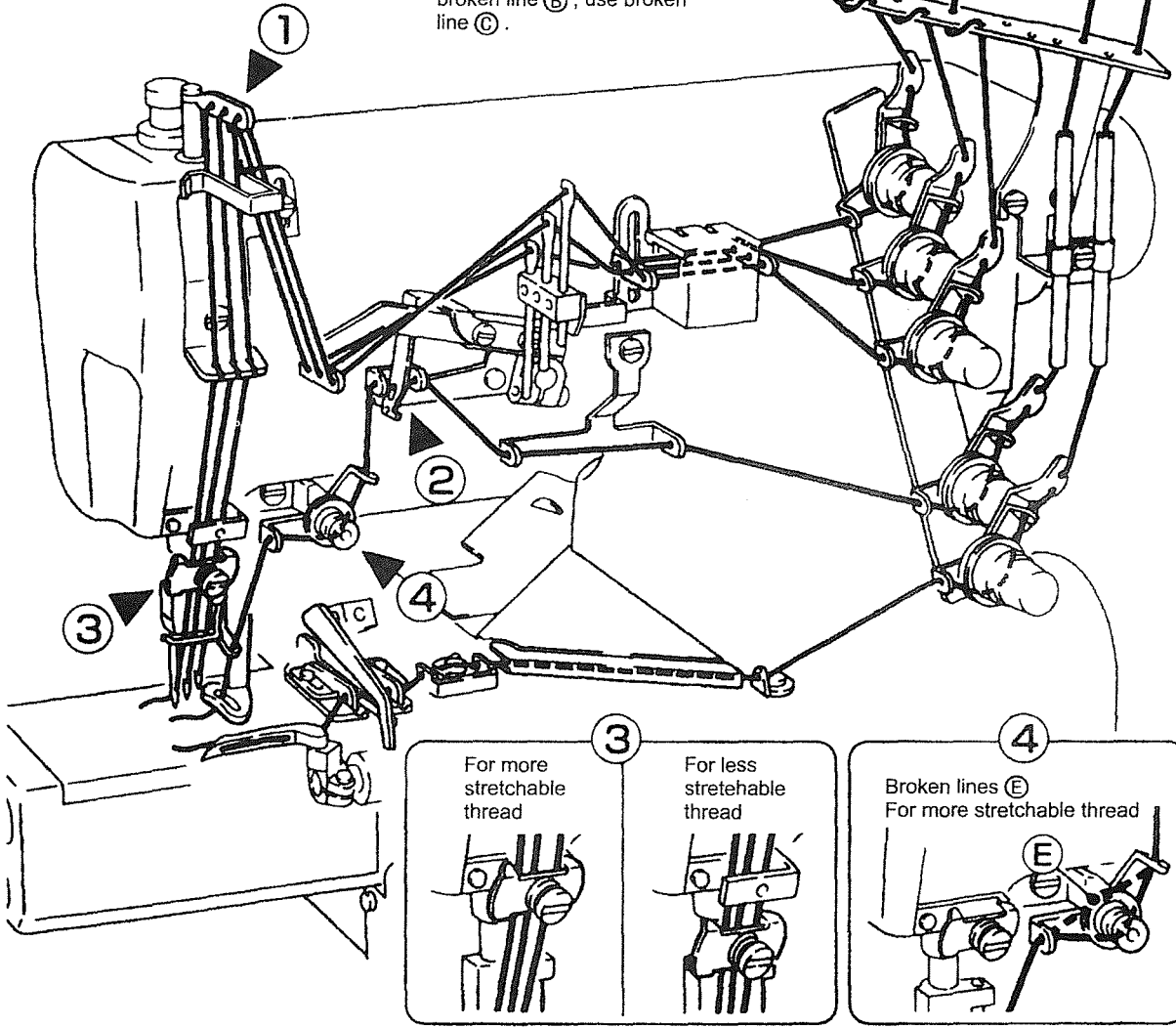
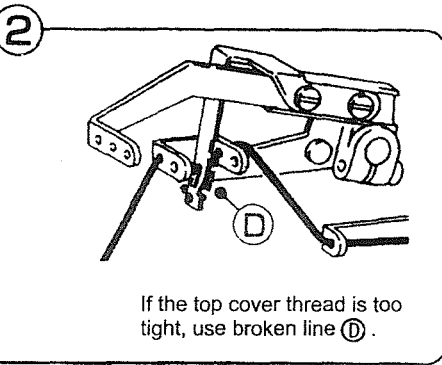
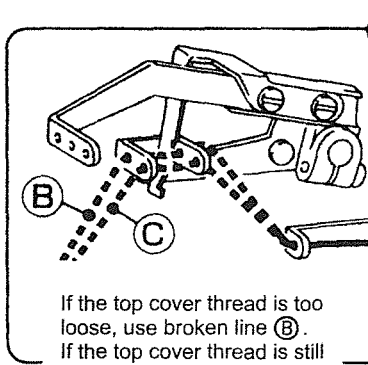
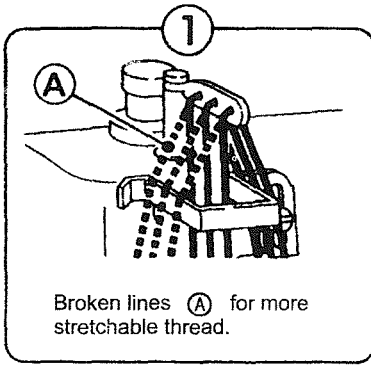

■ TEST SEWING

Adjusting the presser foot pressure

Loosen adjusting nut ① and turn adjusting screw ② to adjust the presser foot pressure. It should be as light as possible, yet be sufficient to obtain the proper stitch formation.

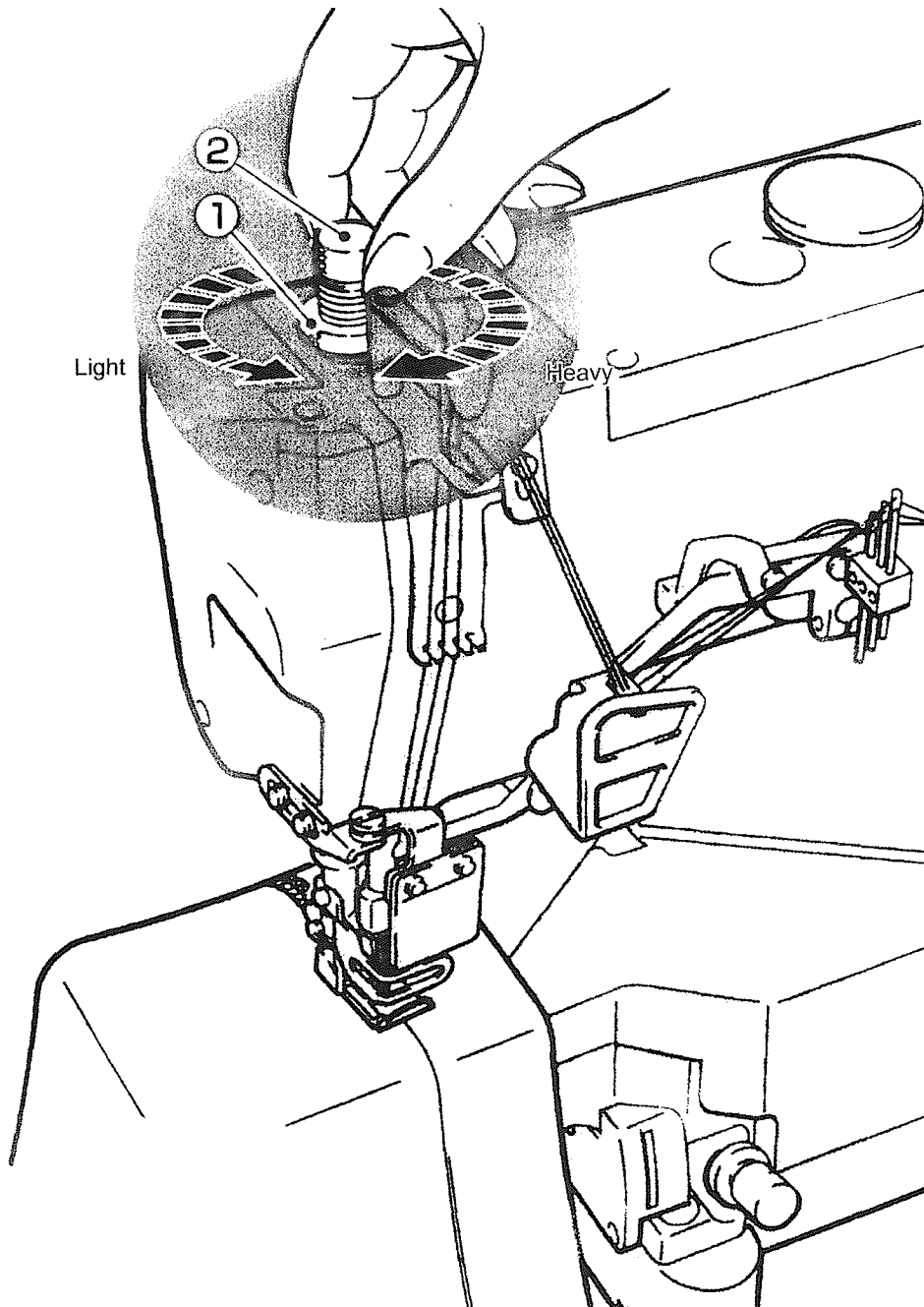

■ TEST SEWING

Adjusting the diff. feed ratio

Loosen nut ① and move the lever up ② and down to obtain the correct differential feed ratio, then tighten nut ①.

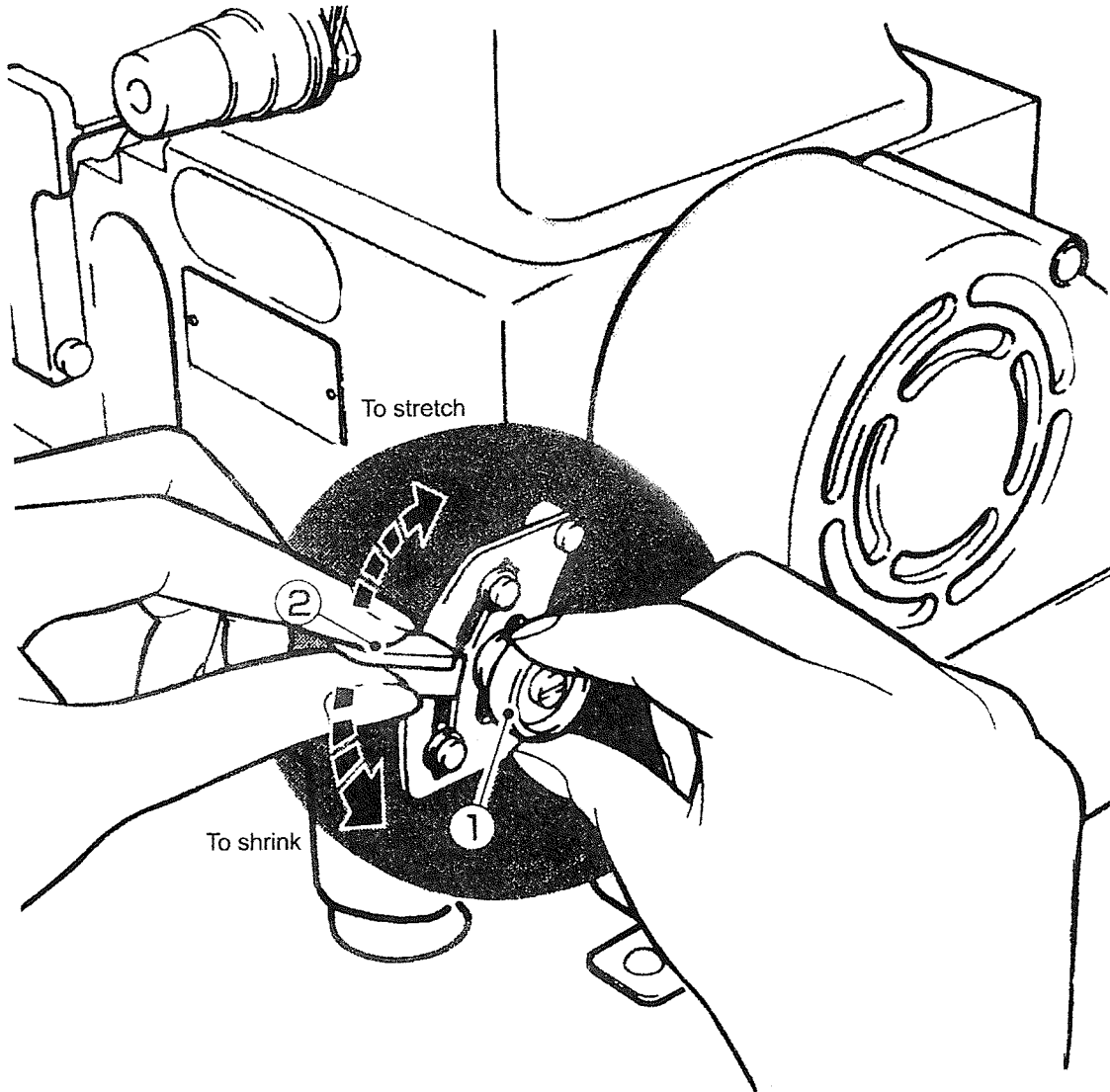

■ TEST SEWING

Adjusting the thread tension

Make tension adjustments with the needle thread knob ①, top cover thread knob ② and the lower looper knob ③.

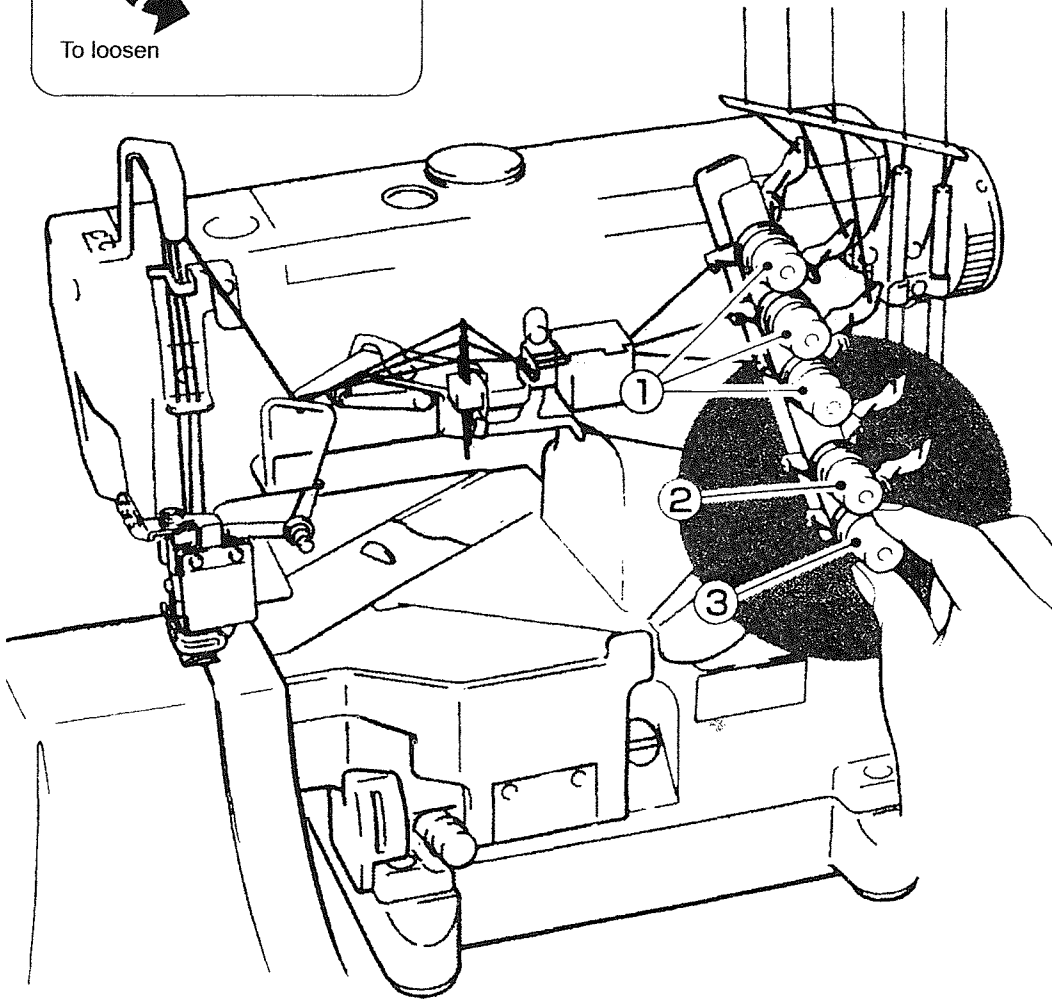
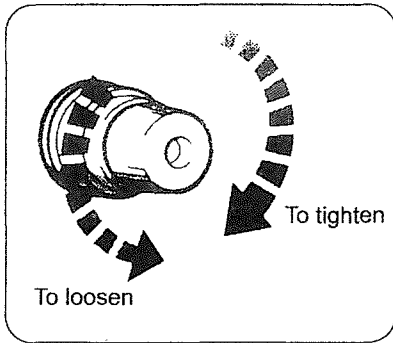

■ TEST SEWING

Adjusting the stitch length

Loosen adjusting screw ① and adjusting nut ② to adjust the stitch length.

Note : Stitch length adjustment must only be made after the differential feed ratio has been changed.

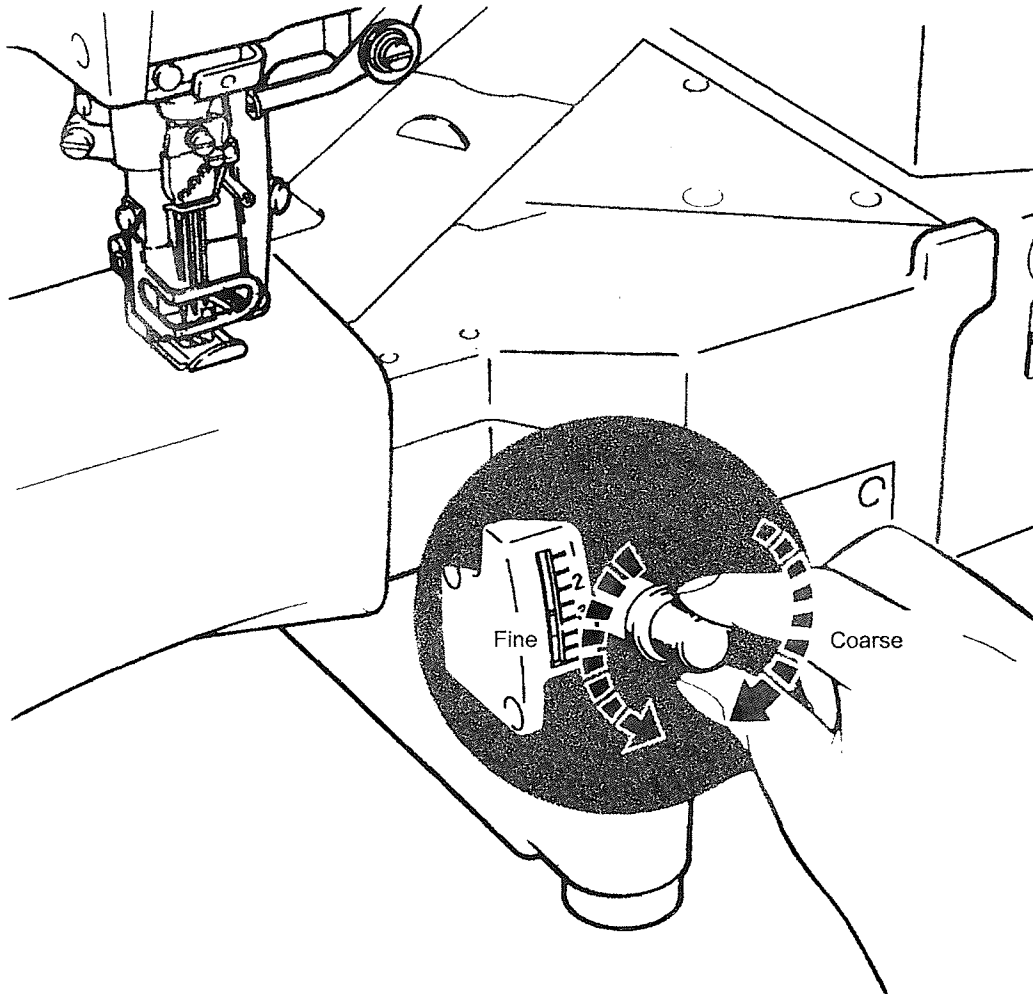

■ MAINTENANCE DURING USE

Cleaning the machine

The slots of the needle plate and the feed dog should be cleaned. It is also necessary to clean the inside of the back rubber plug ①.

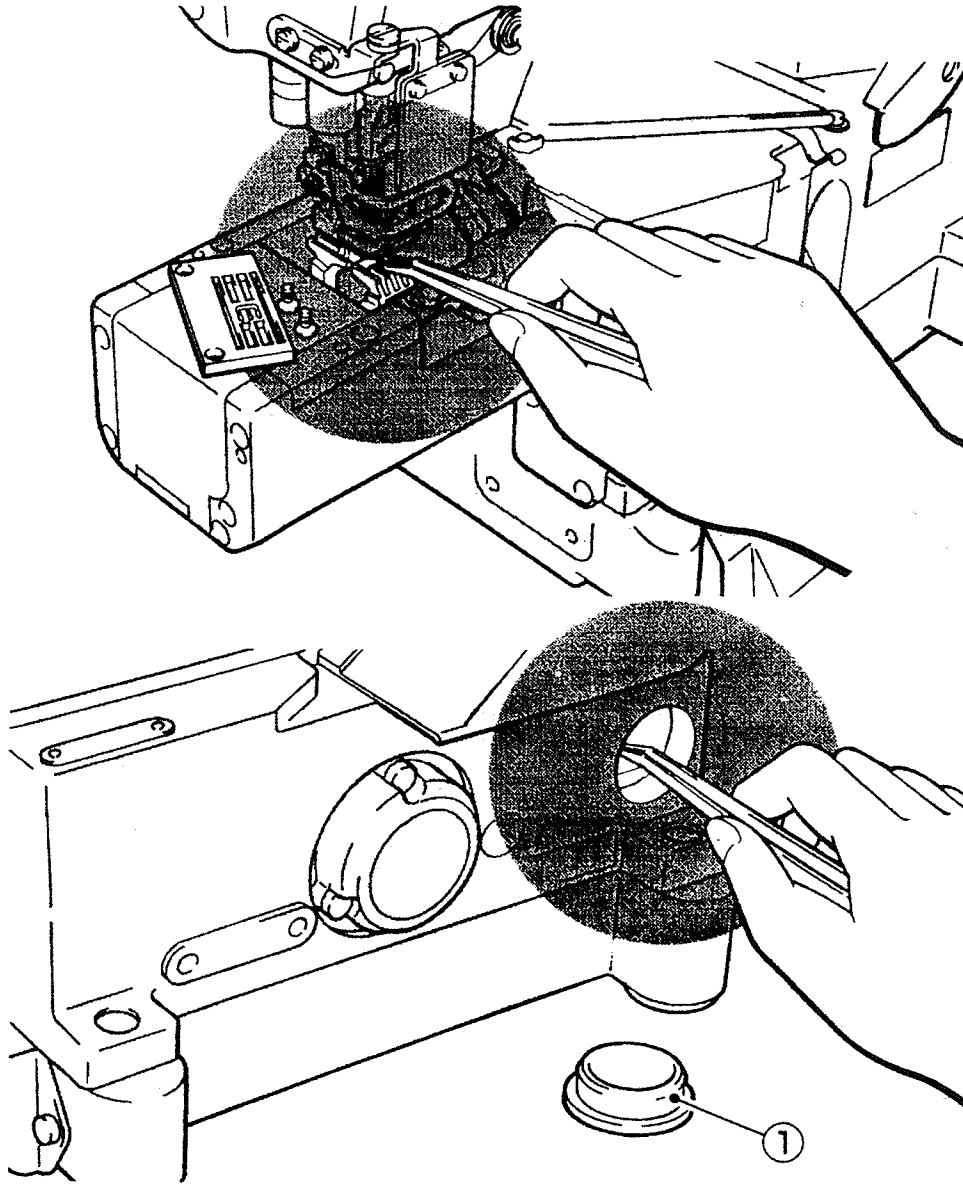

■ MAINTENANCE DURING USE

Replacing the needle

Check the needle carefully to see that the scarf is to the rear of the machine.
Insert the needle to the proper depth, and fasten securely.

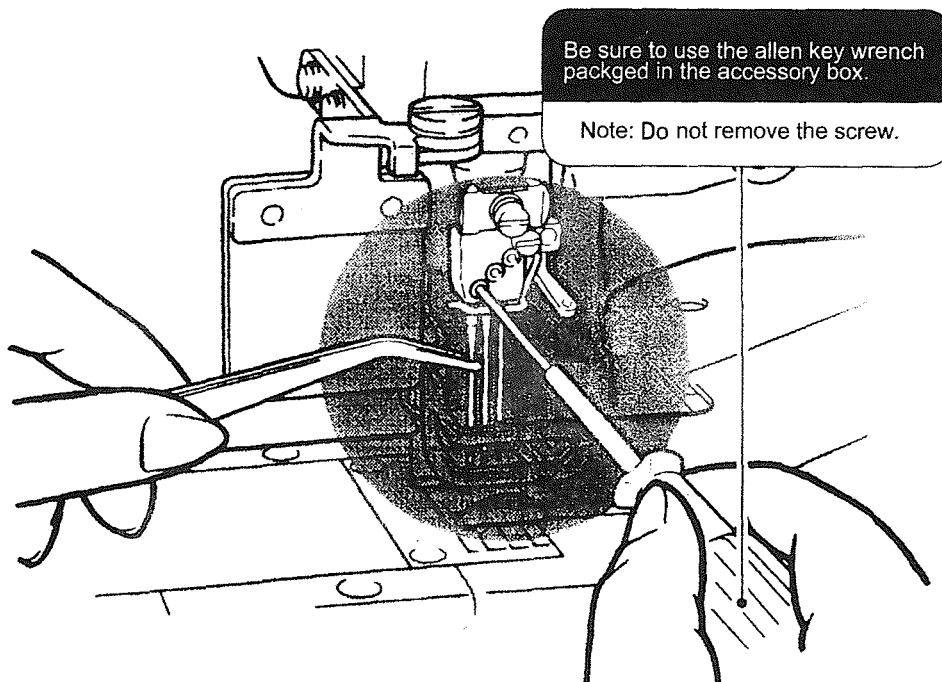
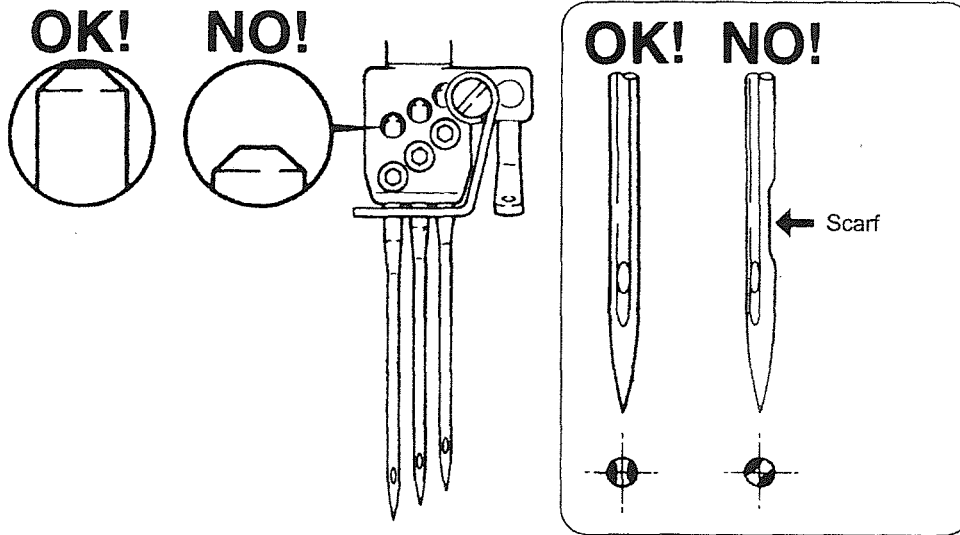

■ MAINTENANCE DURING USE

Checking the oil circulation

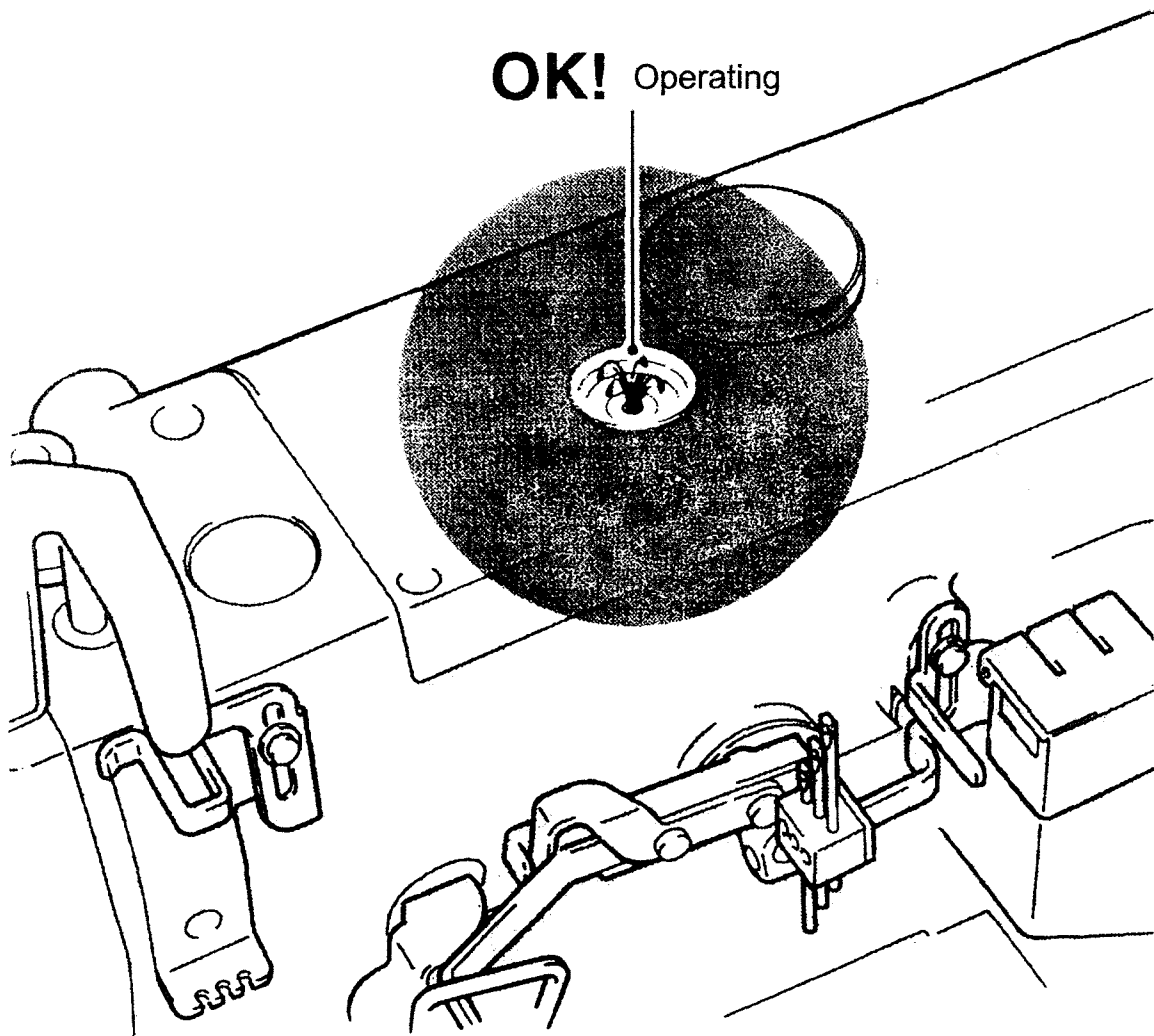

■ MAINTENANCE DURING USE

Checking and replacing the oil filter

Check and replace the oil filter every six months.

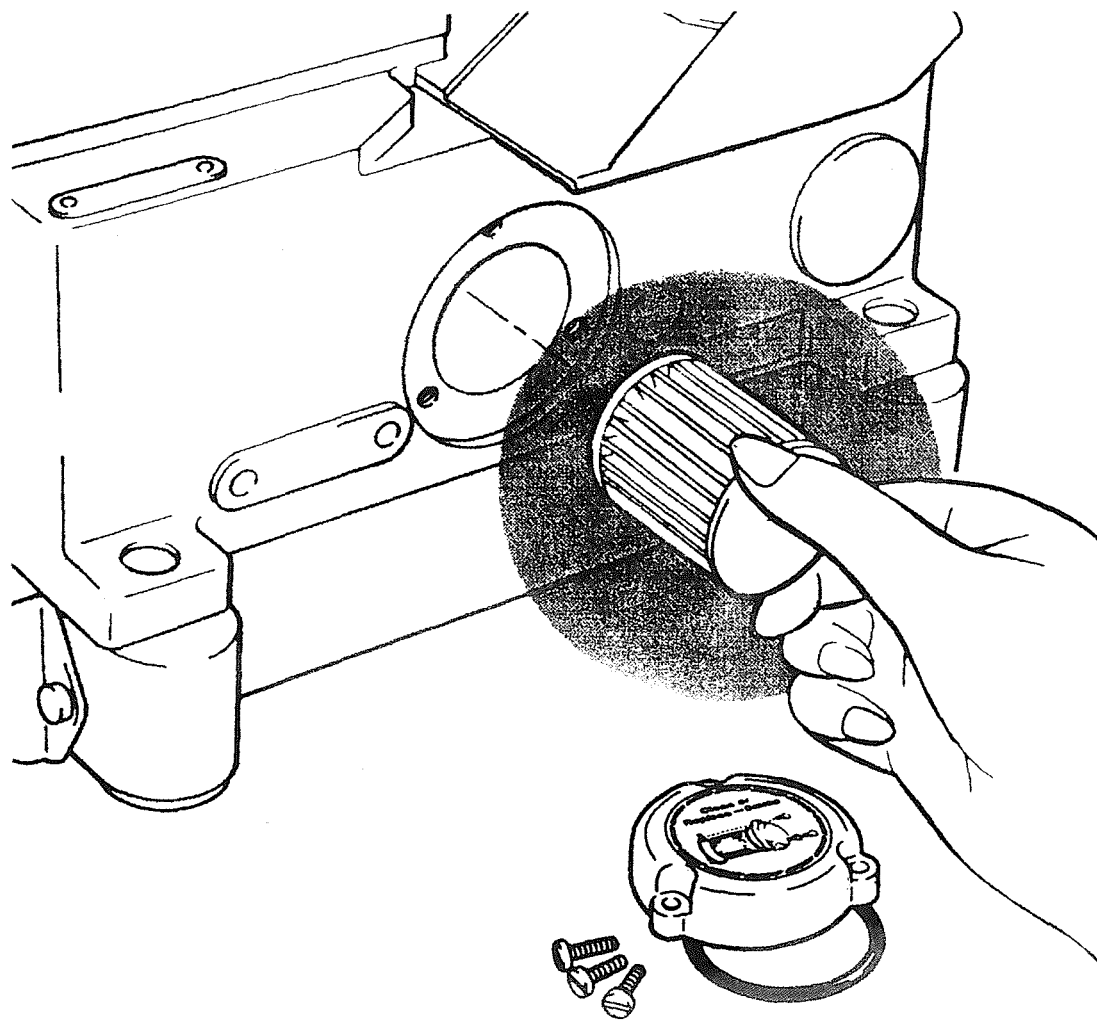

■ **MAINTENANCE DURING USE**

Replacing the oil

Replace the oil one month after the first use and every six months thereafter.

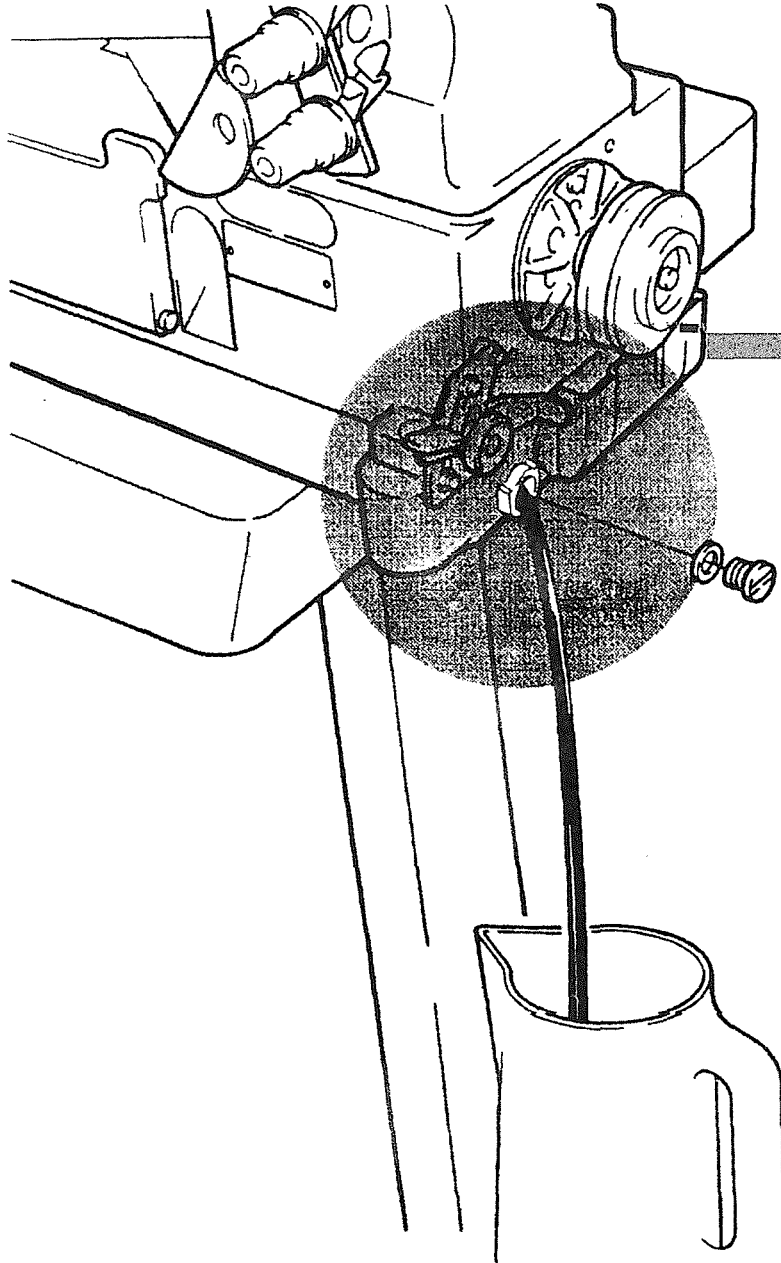

HIGH-SPEED STRETCH SEWING MACHINE

• PARTS CATALOG •

1

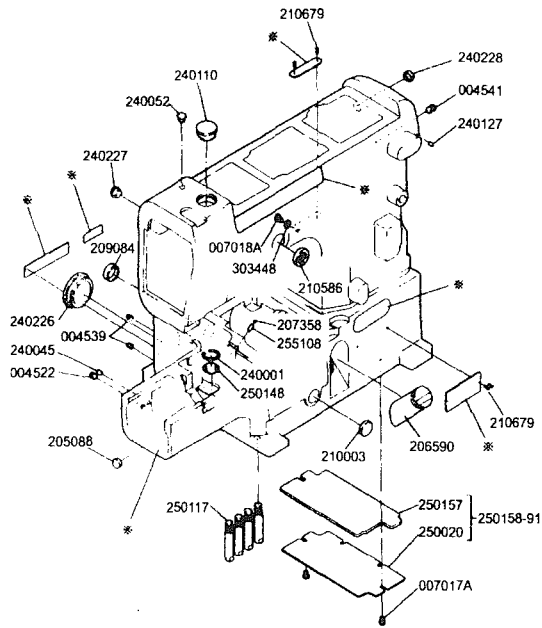

2

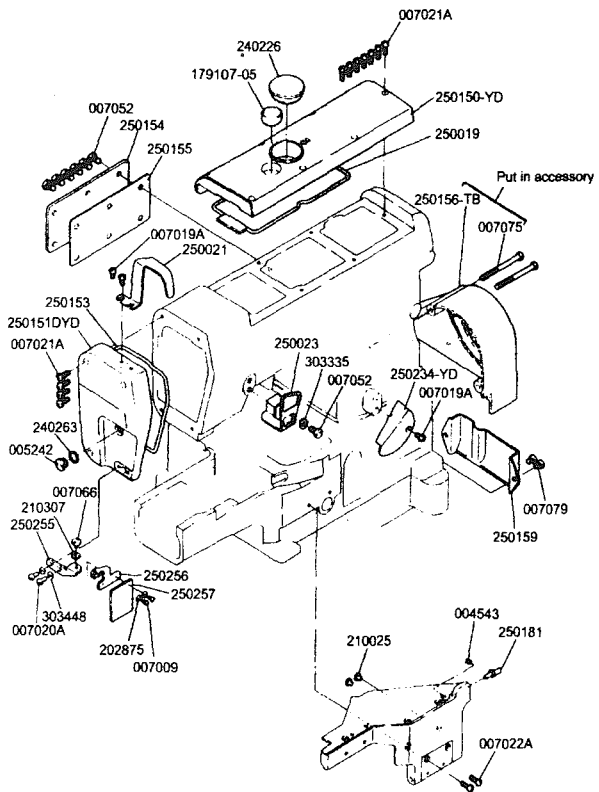

3

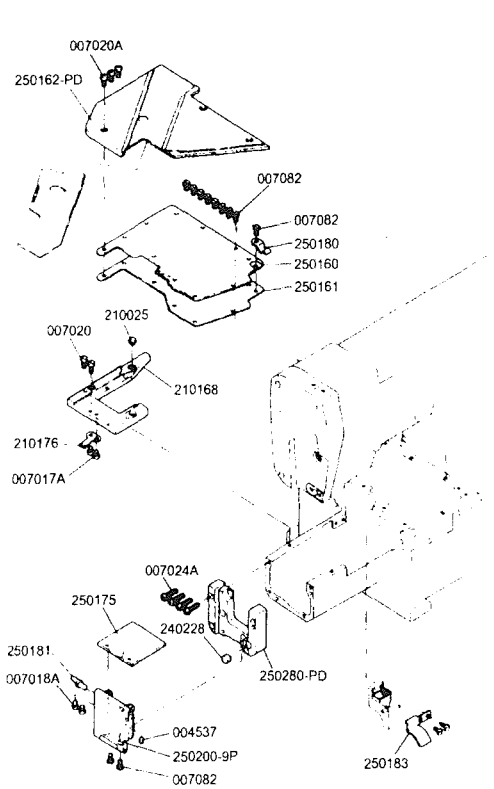

4

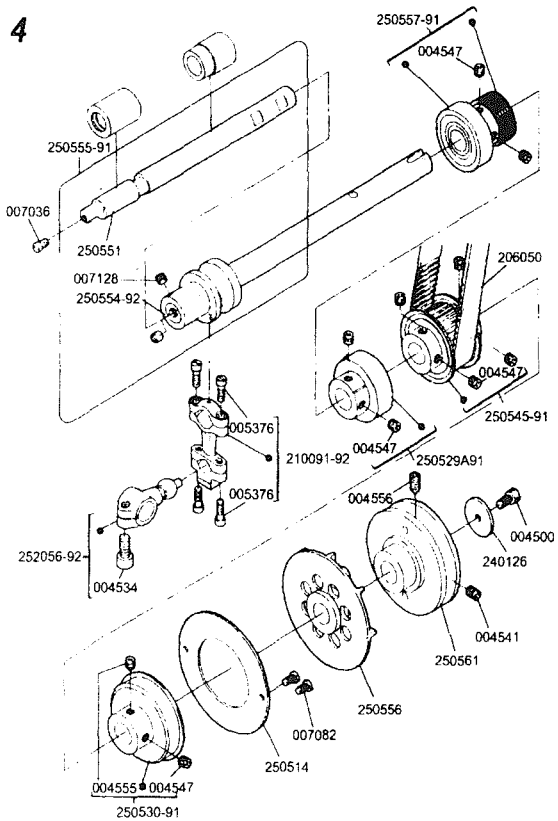

5

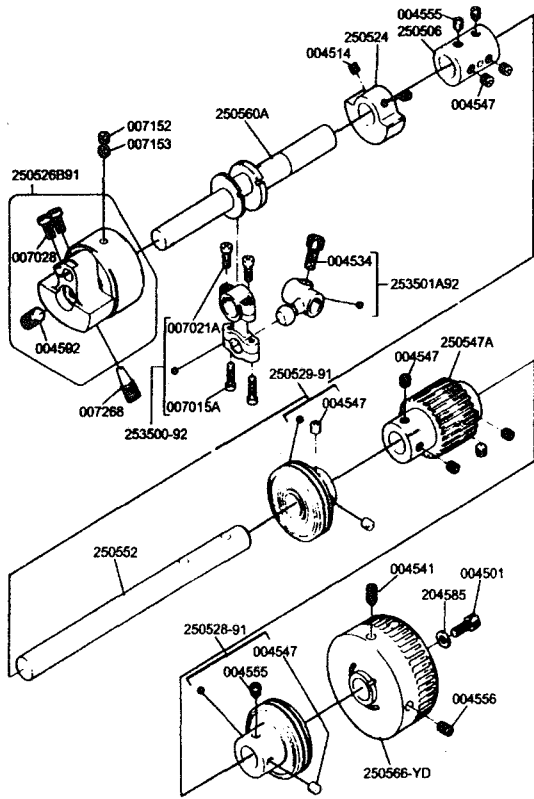

6

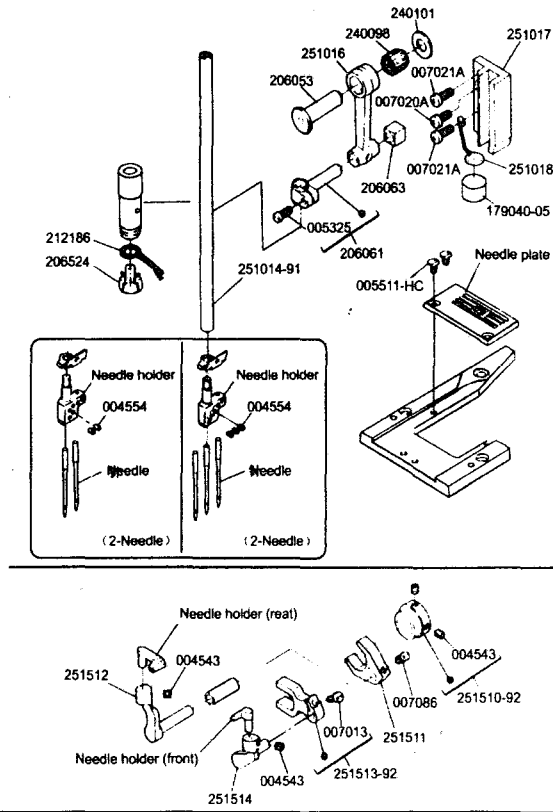

7

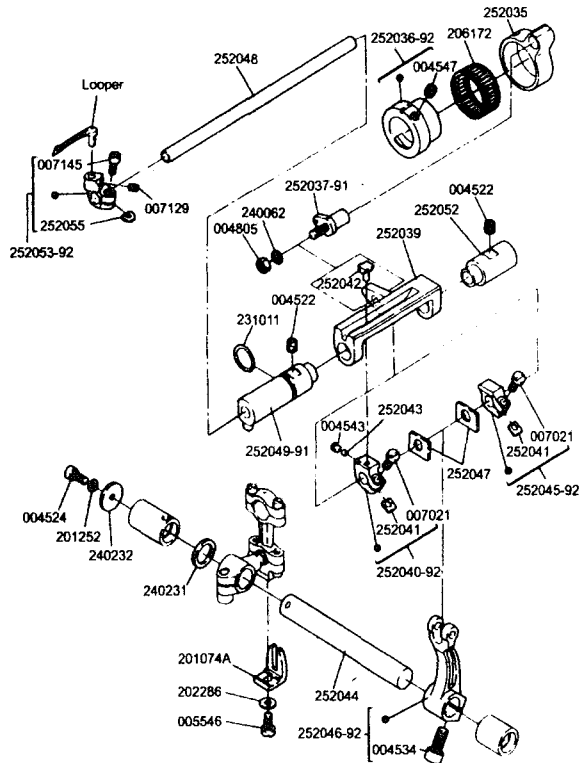

8

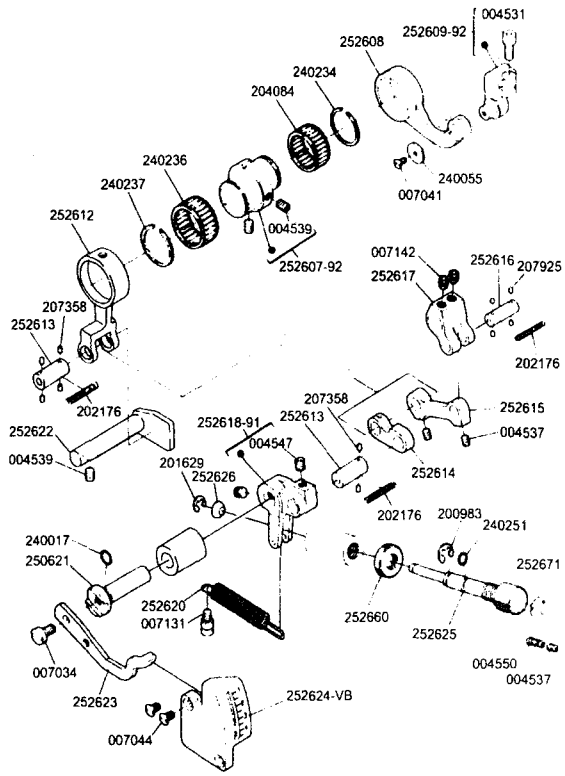

9

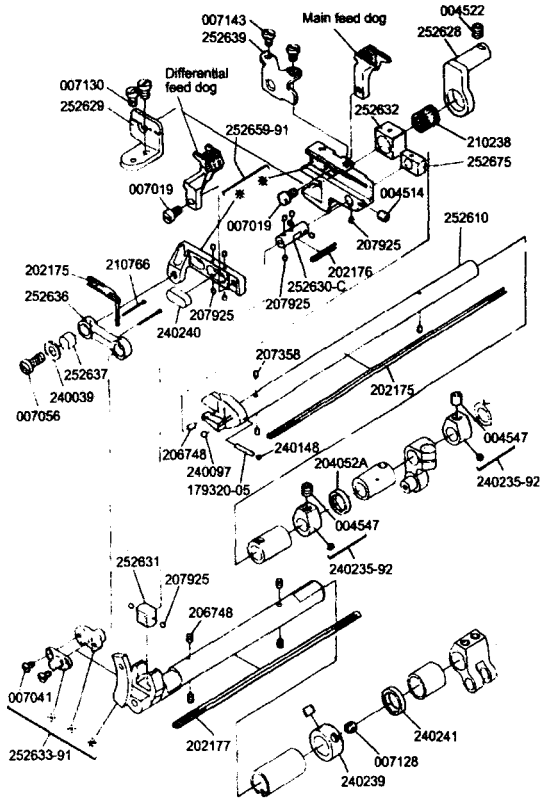

10

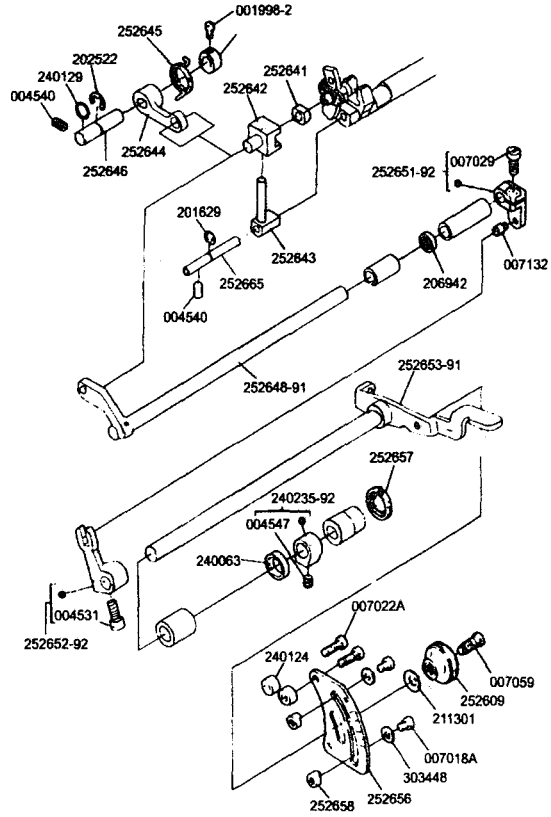

11

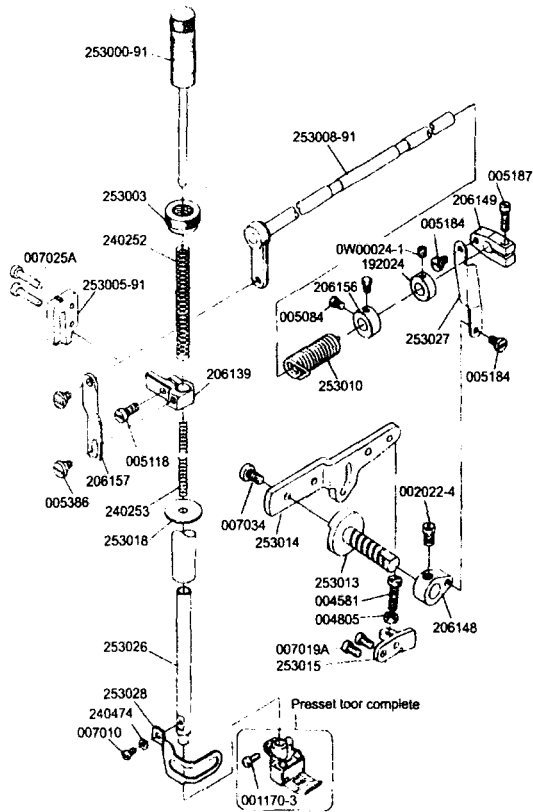

12

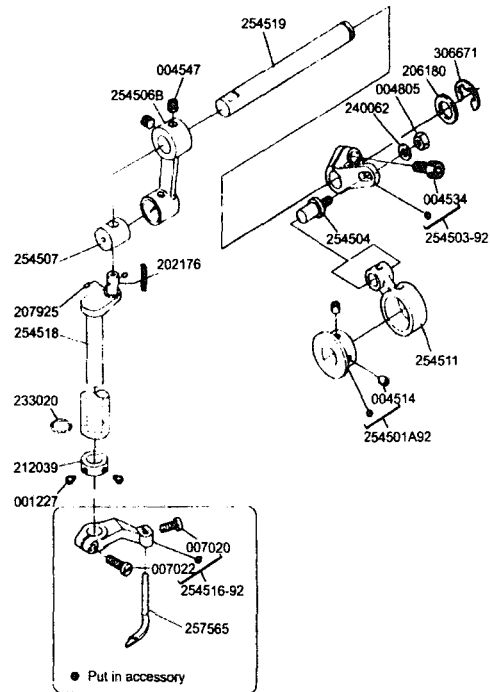

13

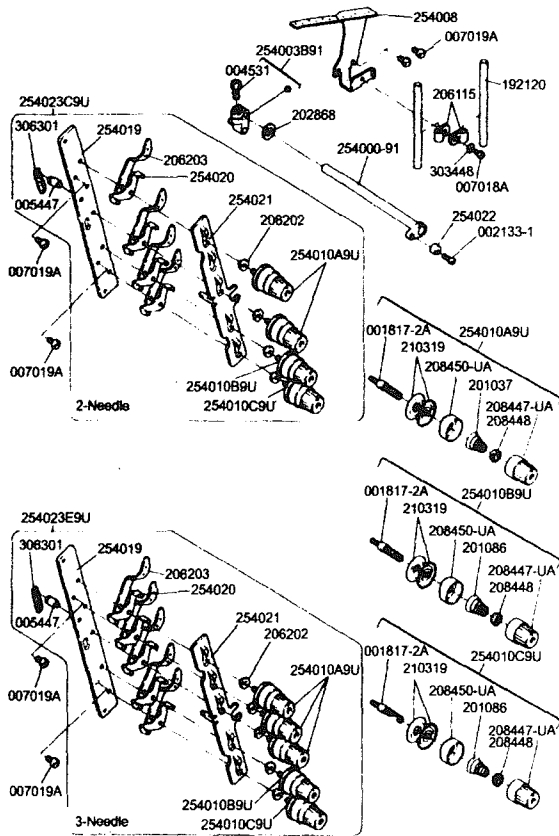

14

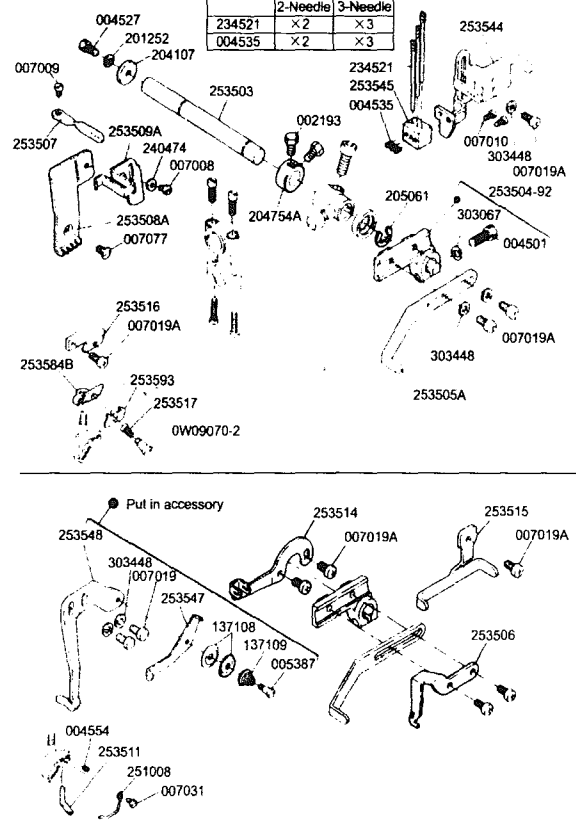

15

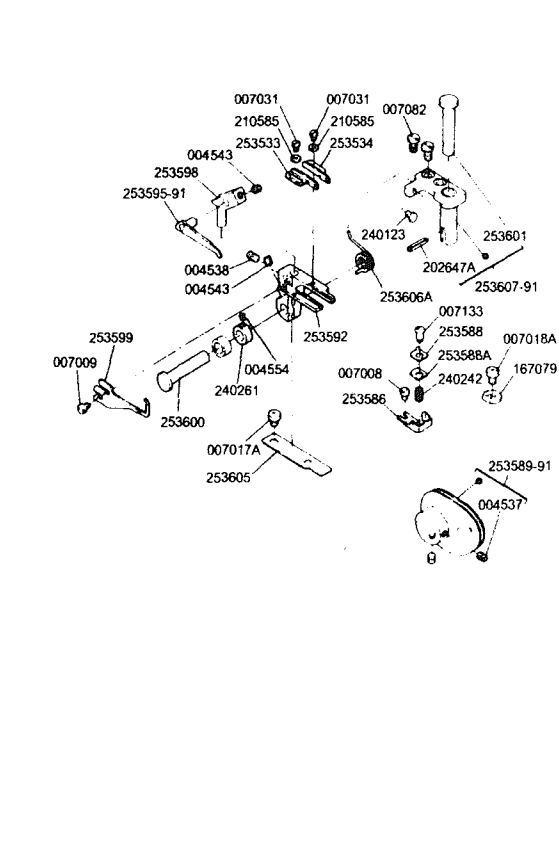

16

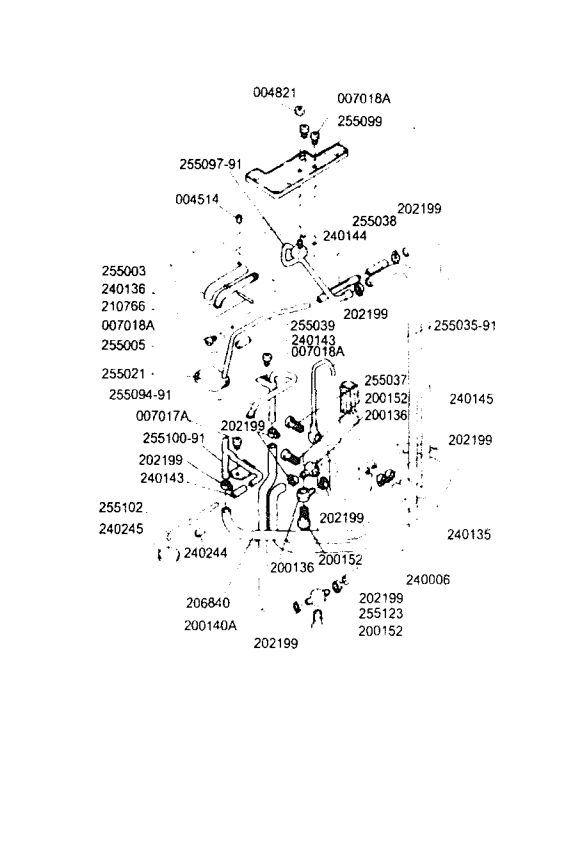

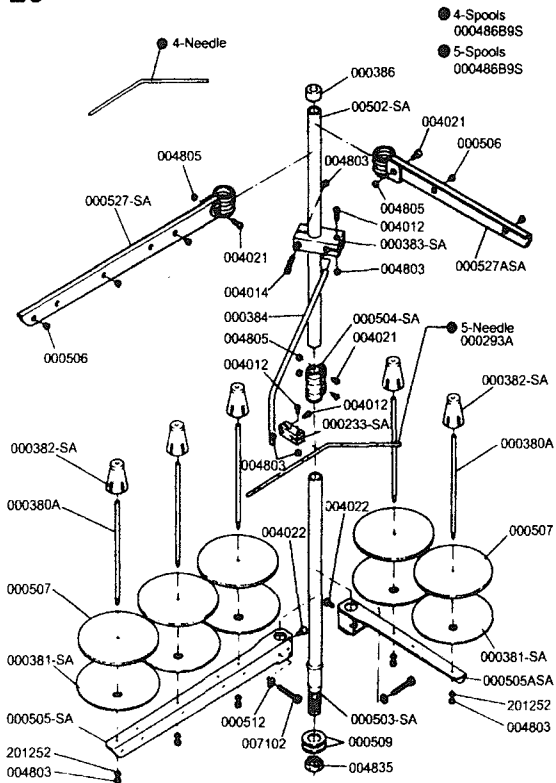
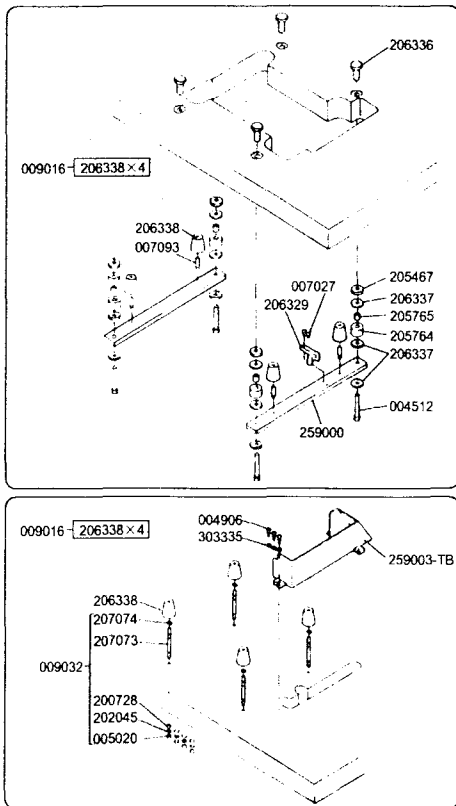
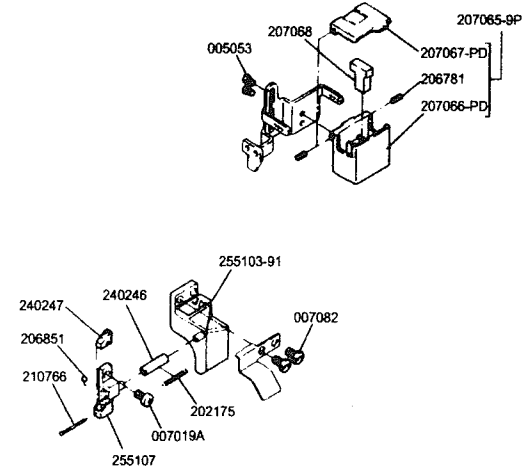
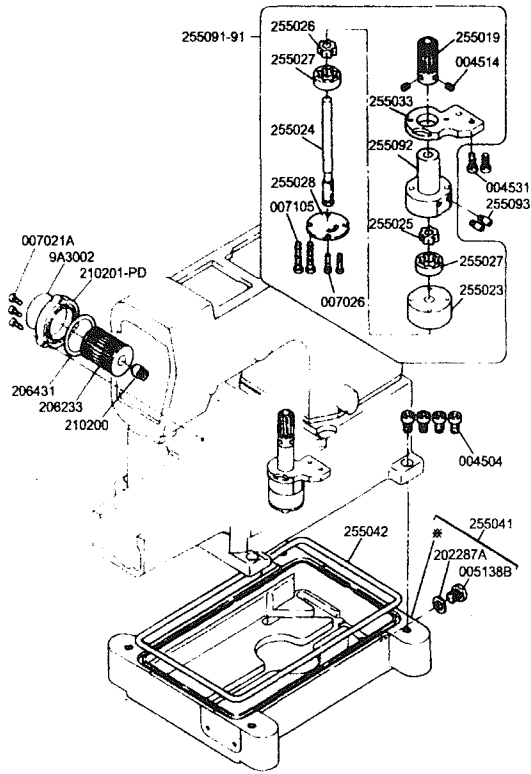

21 • OPTION

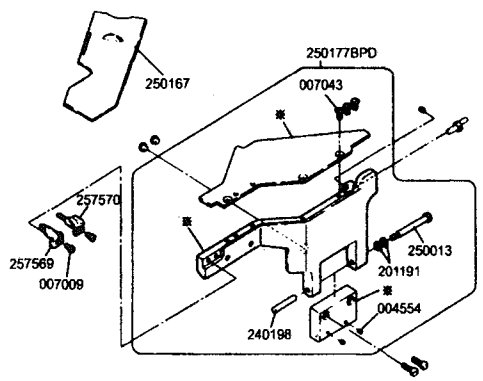
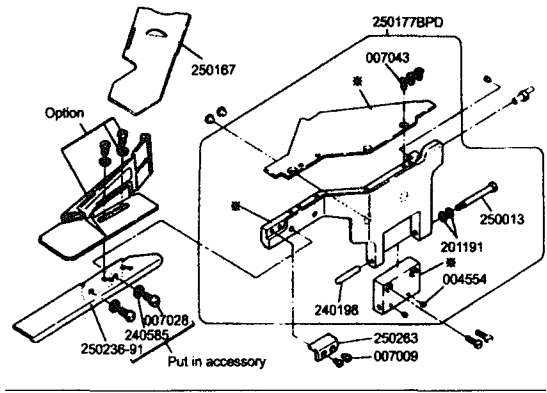

22 • OPTION

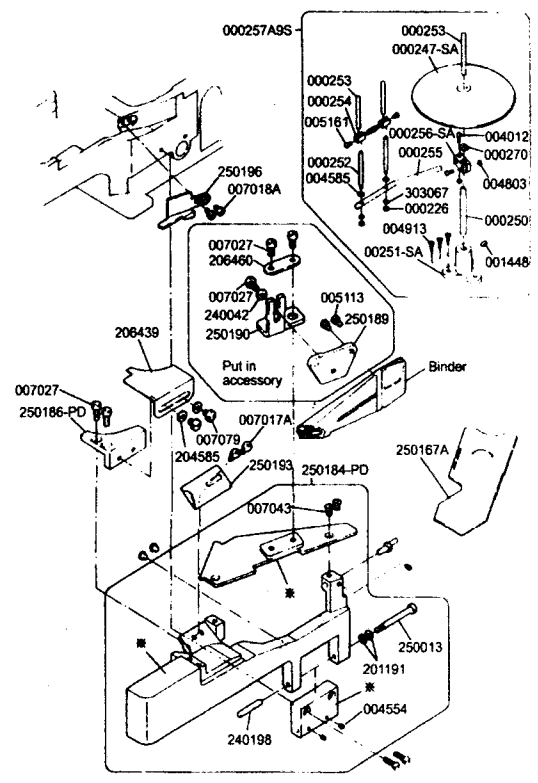

23 • OPTION

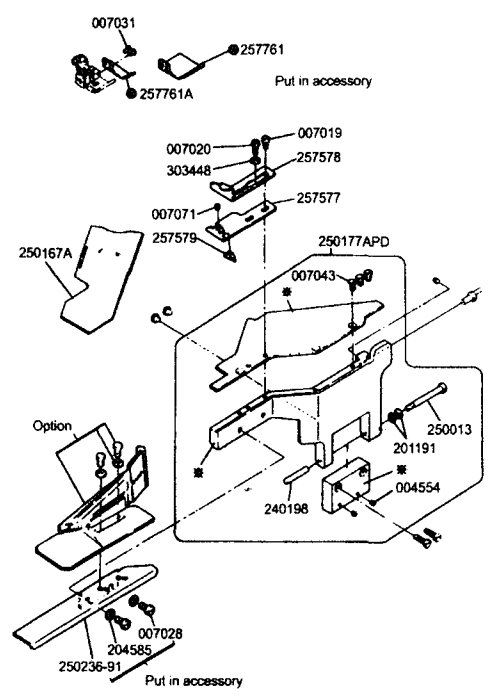

SHANGHAI HUIGONG NO.3 SEWING MACHINE FACTORY

ADD: 1418, Yishan Road, Shanghai, China

Zip Code: 201103

Overseas Business: TEL: 86-21-64853303 FAX: 86-21-64854304

E-mail: highlead@online.sh.cn <http://www.highlead.com.cn>

The description covered in this manual is subject to change for improvement of the commodity without notice

2006.8. Printed

From the library of: Superior Sewing Machine & Supply LLC