

Customer Service
Copy

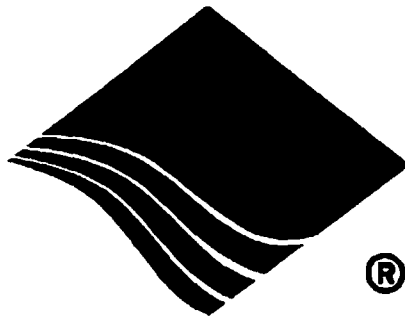

HIGHLEAD

GG0028

**SINGLE NEEDLE FLAT BED ZIGZAG INDUSTRIAL
SEWING MACHINE**

**Instruction Manual
Parts Catalog**

SHANGHAI HUIGONG NO.3 SEWING MACHINE FACTORY

From the library of: Superior Sewing Machine & Supply LLC

**SINGLE NEEDLE FLAT BED ZIGZAG INDUSTRIAL
SEWING MACHINE**

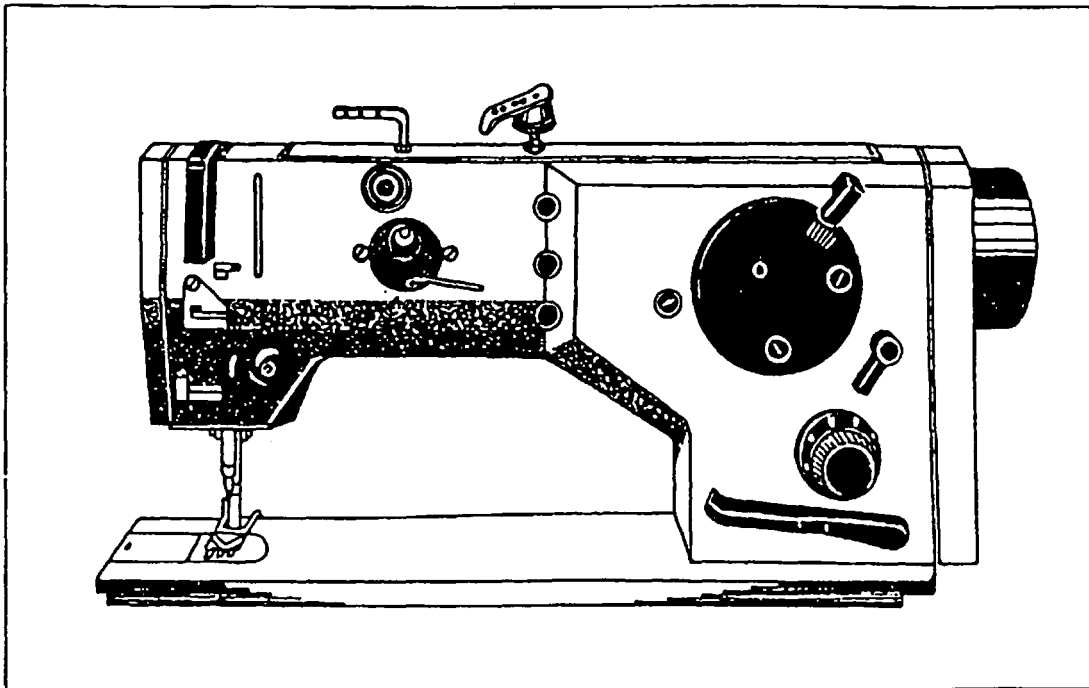

Use of Machine

The machine is used chiefly for stitching upper clothing such as attaching top collar to the under collar tack, stitching collar corners, attaching collar to neck opening, and for other operations consisting in joining rather heavy materials.

Specifications

Machine speed	2200 rpm
Stitch type	two-thread zigzag lockstitch
Stitch length	up to 5 mm, forward and reverse
Stitch width	up to 10 mm
Zigzag stitch width position	median
Needle	Schmetz 134 - 35 Nos. 110 - 130
Hook	R 251
Thickness of sewn material	up to 8 mm
Threads	cotton threads: 14,5 tex x 3 - 35,5 tex x 3 + synthetic threads: PES 25 tex x 1 x 2 25 tex x 1 x 3
Presser foot stroke	8 mm with hand lever 10 mm with knee lever
Clear work space	265 x 120 mm
Machine stand	standard steel profile stand
Weight of machine head	35 kg

+ With synthetic threads, be sure adequately to reduce the machine speed.

Technical description

The machine GG0028 is designed as a flat-bed zigzag two-thread lockstitch sewing machine. The rotary hook, situated in the bed plate and equipped with positive bobbin case opening, rotates in a plane perpendicular to the direction of feed of sewn work. The drive is transmitted, from the lower shaft to the hook, by gear wheels with a gear ratio of 2 to 1, and from the upper shaft to the lower one, by endless belt with a gear ratio of 1 to 1. It is adapted for forward and reverse sewing, and the front part of the machine column holds control elements for setting the stitch length and stitch width. The reverse stitching is actuated by a hand lever, the lifting of the presser foot, by a hand lever or by the left-side treadle. The most important parts of mechanisms subject to increased strain are seated in antifriction bearings. The machine has a group wick lubrication and separate automatic lubrication of the hook. In its basic version, the machine is supplied without lighting, but it is fitted with a screw attachment for fixing a suspension-type lighting.

Machine Equipments and their Use

Ordering No.	Name
522 791 124 027 35	Stitching set - throat plate with needle aperture 1.8 mm; needle Schmetz 134 - 35 No. 120
522 791 149 001 00	Overedging equipment
522 791 995 014 00	Plug for the hole overedging operations
522 792 112 010 00	Built-in frictional bobbin winder
522 794 222 010 00	Suspension-type lighting of work area

The Equipments are supplied on special order only.

Example of application	Thickness of sewn work	Needle Schmetz 134 - 35	Threads	RPM
zigzag stitch, width up to 10 mm	cotton 4 mm	Nos. 100 - 110	cotton 14,5 tex x 2 x 2	3,800
zigzag stitch, width up to 8 mm	cotton 5 mm	Nos. 100 - 110	cotton 20 tex x 3	3,400
zigzag stitch, width 6 to 10 mm	cotton 4 mm with seam crossing up to 8 mm	Nos. 130	cotton 20 tex x 3 35.5 tex x 3	3,000
zigzag stitch, width up to 10 mm	cotton up to 8 mm	Nos. 110 - 130	cotton 20 tex x 3 35.5 tex x 3	2,500
zigzag stitch, width up to 8 mm	blend materials up to 5 mm	Nos. 110	PES 14,5 tex x 3	3,400
zigzag stitch, width up to 10 mm	blend materials up to 8 mm	Nos. 110 - 130	PES 25 tex x 1 x 2 25 tex x 1 x 3	2,500

With blend materials, high sewing speed makes the material melt and stick onto the needle, thus causing thread ruptures and skipped stitches. To prevent it, the machine speed should be adequately reduced.

I. INSTRUCTIONS FOR SERVICING OF MACHINE

A. GENERAL INSTRUCTIONS

1. Read the instructions of the manual carefully and adhere to them.
2. During transport and while unpacking the machine, proceed in accordance with the instructions and marks on the packing.
3. Report any damage which may have occurred during transport to the railway authorities or to the forwarding agents at once. Immediately after unpacking, check the contents against the order and report any discrepancies to us. We cannot recognise delayed claims.
4. Having transported the machine to its work site, remove the preserving grease coating and all dirt. Make sure that no machine part has become loose and that its mechanism is free of any foreign bodies.
5. Lubricate the machine daily!
Before lubrication, always check whether the lubrication places are clean. It is advisable to lubricate frequently in small quantities. Those parts of the machine which are subjected to increased friction or strain should be lubricated several times a day as needed. Top up the oil tank of the hook as needed.
6. Clean the machine daily, especially the parts which become choked by impurities from the sewn material. During the cleaning, carefully check that the machine parts have not become loose.
7. Once a week, during through cleaning, carefully check the whole machine to see that no parts are damaged and that all machine mechanisms operate correctly. Any faults ascertained must be repaired immediately. Once a year, a general overhaul should be carried out, i.e., the whole machine should be dismantled, thoroughly cleaned, all individual pieces and parts of electrical equipment inspected, and faulty or worn out pieces repaired or replaced.
8. Adhere to the safety regulations. Never clean the machine or repair defects while the machine is in operation. Do not remove covers or other safety devices.
9. Electrical equipment of the machine should be kept in a good and safe state in accordance with the electrotechnical and safety regulations. If the machine is provided with a plug always make sure before plugging in that all switches are off. Never try to repair any defects of the electrical equipment by yourself but call in an expert electrician.
10. We cannot assume any responsibility for faults resulting from non-observance of these instructions.

B. PACKING, UNPACKING, CLEANING AND LUBRICATION OF MACHINE

1. Packing of machine

The machine head is seated in a separate case, the stand either in crating or in a separate case (for severe climate conditions).

2. Unpacking of machine

When taking over the machine from the railway authorities or in the works ascertain whether it has arrived in good order. Report any damage which has occurred during the transport to the railway authorities or to the forwarding agents immediately. Unpacking should be carried out carefully so as to prevent damage to machine parts. Further check the accessories of the machine against the order and report any discrepancy immediately, as we cannot consider belated claims.

3. To set the machine on stand

After the machine has been brought to its work site, set it on the rubber washers of the stand. When seated properly, a gap of approximately 1.5 mm will appear between the bed plate and the rim of the stand plate on the whole of its circumference.

4. To set and fix the machine

Fix the machine using the levelling foot of the stand fitted with adjusting screw. Otherwise, the machine is designed as a stable unit with the stand requiring no fixing to the floor.

5. To clean and lubricate the machine (Fig. 1; Tabs. 16, 17)

Before putting the unpacked machine into operation, remove the protective grease coating and clean the machine thoroughly. For oiling all machine mechanisms and the hook is recommended heavy white vaseline oil with viscosity of $50 \text{ mm}^2 \cdot \text{s}^{-1}$ at 20°C . With an oil can, drip oil into the marked holes of the machine arm once a day, before the beginning of the work shift. Check also the level of oil at the indicator of the hook oil tank. The gear wheels of the hook gear box receive oil from the felt inlay situated on the gear box bottom. The hook and its mechanism should be cleaned several times a day. Apply two or three drops of kerosene to all soiled parts of the hook and of the surrounding mechanism, let the machine run at high speed, then stop it wipe off flushed out dirt, and oil the hook with its mechanism with oil. This cleaning should be carried out daily, especially after the end of the work shift, in order to prevent dirt from drying on the hook and its mechanism. From time to time, use grease nipple to refill the shafts (7, Tab. 16) and (6, Tab. 17) with lubrication grease. Before proceeding to clean the machine, thread and take the hook bobbin out of the hook. Once a week, the machine should be thoroughly freed of settled oil and of all impurities.

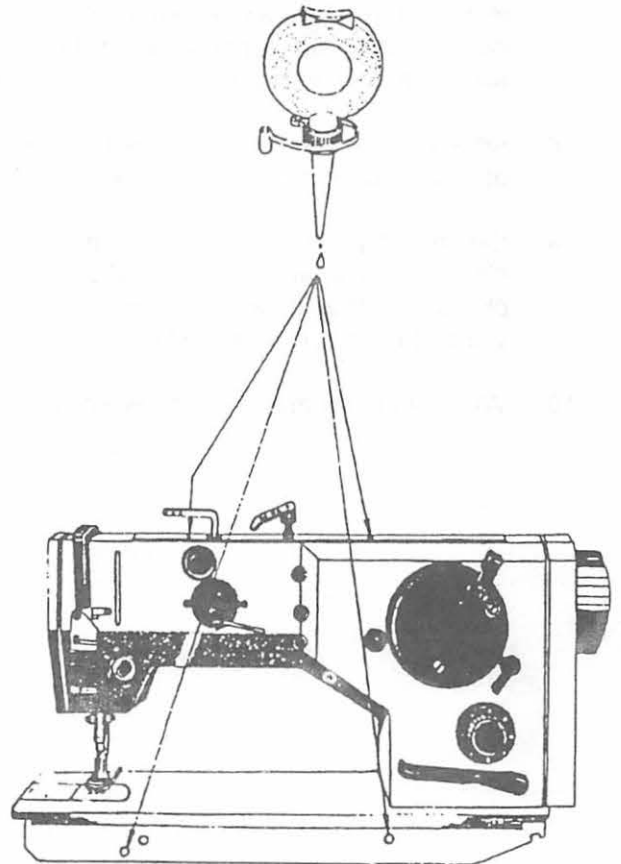

Fig.



Warning I

Before proceeding to clean and lubricate the machine, be sure to switch off the main switch and hold your feet away from the machine stand treadles in order to avoid accidental machine start by treadle actuation.

6. To adjust the hook lubrication (Fig. 2)

To adjust the oil flow to the hook, turn with a screwdriver the adjusting pin (1), located on the front side of the oil tank under the bed plate, from zero to maximum (to the left, anticlockwise). Adjusted at zero, the regulation still provides for a minimum oil flow to the hook preventing it from seizing. After the machine has been put into service, check at regular intervals the oil level both in the hook oil tank and in the oil tank situated on the machine arm.

Caution I

At the beginning of work after a relatively long interval, e.g., at the beginning of the morning shift, it is advisable to remove from the hooks the gathered superfluous oil, either by letting the machine run idly for a short period time or by producing a few stitches (20 cm approximately) on a test material, to prevent the threads and, consequently, the sewn work from getting soiled by oil.

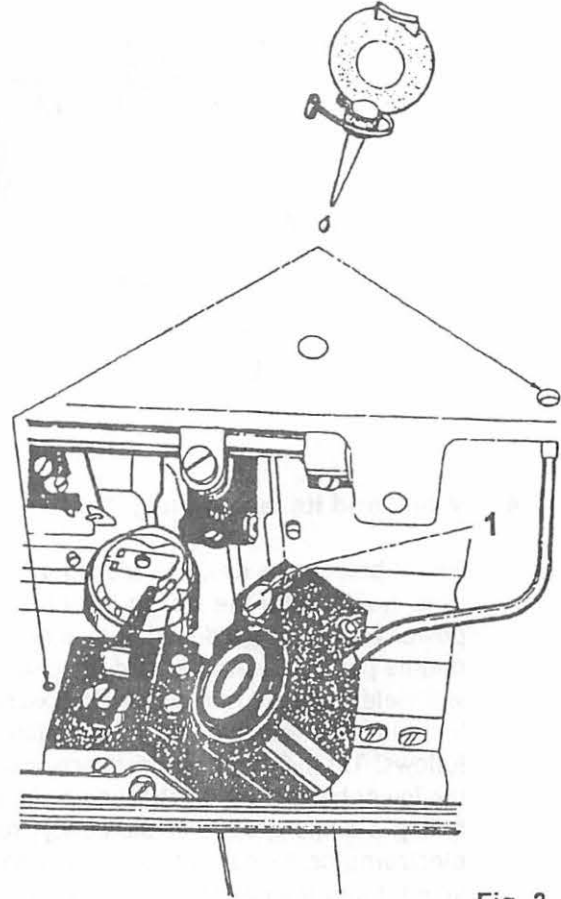

Fig. 2

C. TO PREPARE THE MACHINE FOR SEWING

1. General inspection

Inspect the machine thoroughly for loose parts as well as for the presence of foreign bodies. Rotating the hand wheel by hand, check first whether it revolves freely and whether the machine is adjusted correctly. Further check the correct working of the mechanism controlling the lifting and sinking of the presser foot by means of the knee lever, and the reverse stitching by means of the hand lever or of the left treadle.

2. Sense of rotation

The handwheel must turn in the direction of the red arrow on the belt guard.

3. Electrical equipment

An electrician connects the machine to the mains. Switch on the electric motor and check whether the pulley turns in the correct direction, i.e., to the left. If this is not the case, the plug of the lead-in cable must be taken out and the cable must be switched over on the plug or on the terminal board of the electric motor. An incorrect sense of rotation of the pulley is inadmissible.



Warning I

Avoid any intervention into the electrical equipment of the machine but call in an electrician. Unqualified intervention involves the risk of accident by electric shock.

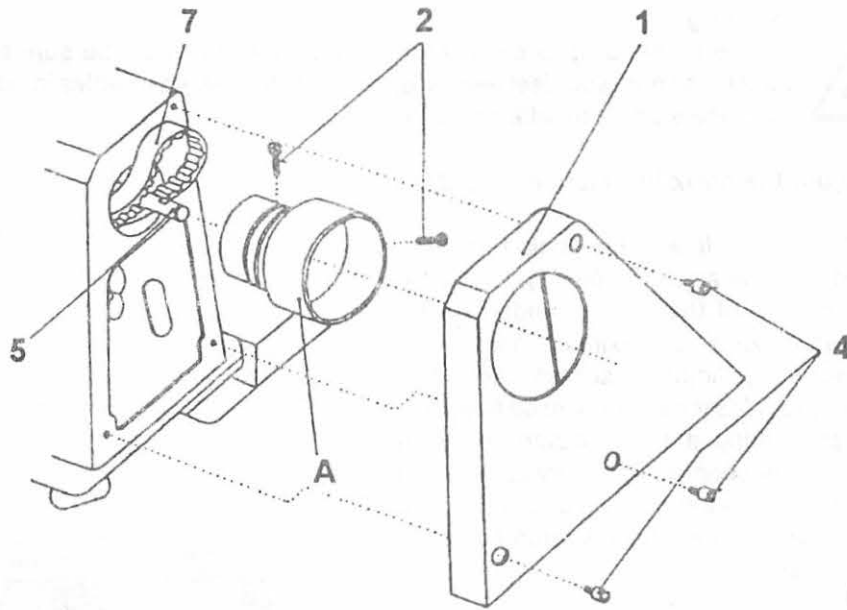

Fig. 3

4. V-belt and its tension (Fig. 3)

The V-belt can be easily tensioned by means of the electromotor that can be displaced in the guiding of its holder after the loosening of two screws. The correct belt tension ensures transmission of full power with losses reduced to minimum. To check the tension of the V-belt, depress it lightly in the middle part between the hand wheel and the pulley; if the belt tension is correct, the pressed-on part will yield some 20 mm sideways. Excessive tension of the V-belt reduces the machine output and increases both the power consumption and the wear of bearings. To remove the V-belt, proceed as follows: Tilt the machine head, screw out the screws (4), remove the upper belt guard (1), and from the lower belt guard the sheet piece fixed by screws to the stand plate and protecting the V-belt from falling out the groove of the pulley, remove the V-belt, mount a new one onto the pulley of the electromotor, fix it by attaching back the sheet piece, pass it between the tank and stand plate, and insert it into the hand wheel groove. Lift the machine to its operational position, check the V-belt for correct tension, and mount the upper belt guard.

5. To lift the presser foot (Fig. 4)

The lifting and sinking of the presser foot is controlled by the knee lever mechanism. To lift the presser foot and to lock it in the lifted position, the hand lifting lever (12) situated at the rear side of the machine arm also can be used. To sink the presser foot onto the sewn work, first slightly depress the knee lever thus disengaging the locking of the lifted presser foot by tilting the hand lever, and then release the knee lever to let the presser foot sink onto the sewn work. Never start the machine if the presser foot has been sunk onto the throat plate directly, with no material interposed between them.

6. Needles and threads

The machine requires the use of needles Schmetz 134, 134 LR and 797 CFCF Nos. 110 - 130. Considering the high machine performance and the resulting needle heating, it is advised to use chromium plated needles.

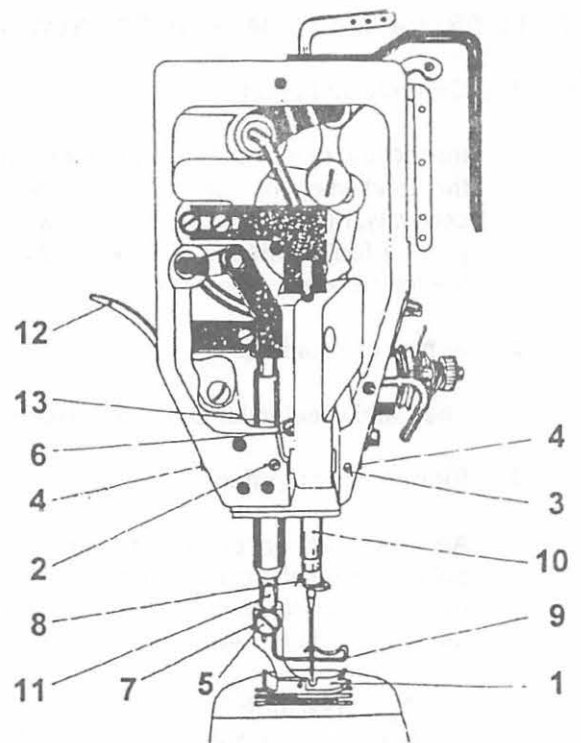

Fig. 4

The size of the needle depends on the size of the thread, since it must pass freely through the needle ear. It is advisable to choose a rather thin needle, just permitting the free passage of the thread through the needle ear but helping to prevent the upper thread from being threaded out of the needle ear at the beginning of stitching after the previous thread trimming. The needle size should be adequate to the thickness of sewn work. A needle too thin with respect to the thickness of sewn work is subject to excessive strain (impacts at the needle punches into the work, upper thread tension, heat generated by friction between the needle and the sewn work, etc.) and exposed to the risk of deviations from the correct needle course followed by irregular formation of the upper thread loops and resulting in skipped stitches. Only high-class threads should be used. Especially suitable are conical cross-wound bobbins. S-twist threads should be used for the needle, while both S-twist and Z-twist thread is suitable as lower thread. A coarse thread or one which has to overcome considerable resistance when passing through the needle ear reduces the machine performance and increases its trouble incidence. With synthetic threads, the sewing speed should be reduced accordingly, to prevent the threads from melting.

7. To insert the needle (Fig. 4)

To facilitate the needle insertion, sink the presser foot onto a bit of material and rotate the hand wheel toward you until the needle bar has reached its top position, i. e., until the greatest possible distance between the needle bar and the throat plate has been obtained. Loosen the screw (8) on the lower part of the needle bar and insert the needle up to the stop. Be sure that the long groove of the needle is directed toward the operator. Looking through the cross slot provided in the needle bar check whether the needle shaft has reached the bottom of the needle channel, and fix the needle by tightening the screw. Each time you insert a new needle check whether it is straight and whether it passes through the centre of the needle aperture provided in the throat plate. Never use a needle chosen haphazardly but choose it with respect to the character of the sewn work and to the thread size.



Warning I

Before proceeding to exchange the needle, be sure to switch off the main switch and hold your feet away from the machine stand treadles in order to avoid accidental machine start by treadle actuation.

8. To thread the upper thread (Fig. 5)

Put the bobbin on the bobbin stand, unwind a sufficient portion of it, and pass it through the thread guide of the bobbin stand, then through the thread guides (4) and (1) between the tensioner disks (8), then lead it through the adjusting spring (2), the thread guides (3 and 6), and the auxiliary thread guide (9) into the thread take-up lever (A), then downwards through the thread guide (6) and the lower thread guide (7) to the thread guide (5) on the needle bar, and from there to the needle. Insert it into the needle ear from the front side (i. e., from the side of the operator) to the rear side.



Warning I

Before proceeding to thread the machine, be sure to switch off the main switch and hold your feet away from the machine stand treadles in order to avoid accidental machine start by treadle actuation.

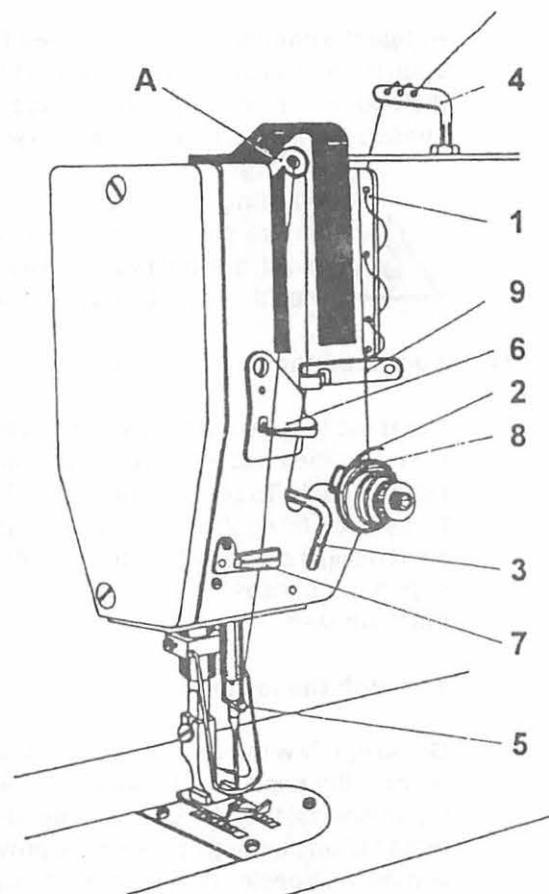

Fig. 5

9. To wind the hook bobbin (Fig. 6)

To wind the lower thread on the hook bobbin, a built-in bobbin winder, supplied separately as Equipment No. 522 792 112 010 00, can be mounted onto the front side of the machine arm. Lead the thread from the bobbin stand through the apertures provided on the arm of the bobbin stand and in the thread guide (6) to the bobbin mounted on the winder shaft, wind it a few times anticlockwise on the bobbin, lead the thread end to the spring (2), insert it between the spring coils, and apply mild pressure so as to cut it by the knife situated inside the spring. When mounting the bobbin on the winder shaft be sure that the carrier spring enters the notch of the bobbin front. Swinging the control lever (5) between the bobbin fronts will render the bobbin winder operative. Switch on the electric motor and depress the right treadle to start the machine and by this the winder as well. During the winding, the thread is evenly distributed along the whole of the bobbin width. As soon as the bobbin is fully wound, the control lever springs off thus disconnecting the winder drive and braking the winder shaft. The winding is completed. Using the knife mounted in the spring (2) cut off the threads end. For timing the winding stop, loosen the screw (4) of the control lever (5) mounted on the disconnecting pin (3), hold the disconnecting pin in its position with a screwdriver and adjust the angular position of the control lever on the disconnecting pin as required.

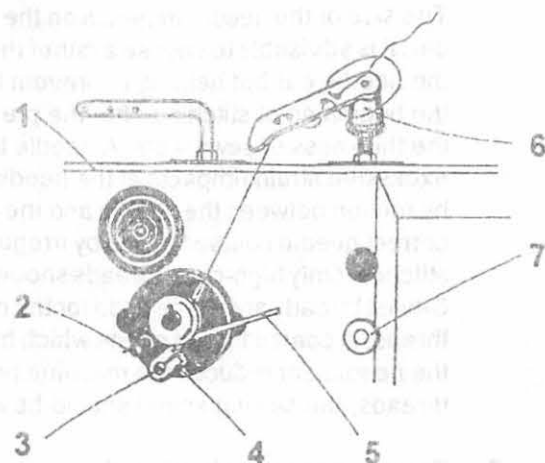

Fig. 6

10. To take out the hook bobbin

Rotate the hand wheel until the thread take-up lever has reached its top position. With your left hand, open the lock of the bobbin case and take the bobbin case out. As long as the bobbin case lock is open the bobbin is held in the bobbin case. Release the lock and take the bobbin out of the bobbin case. Loosen the lock, turn the bobbin case upside down, and the bobbin will fall out.



Warning !

Before proceeding to exchange the bobbin of the hook, be sure to switch off the main switch and hold your feet away from the machine stand treadles in order to avoid accidental machine start by treadle actuation.

11. To thread the lower thread

Insert the fully wound bobbin into the bobbin case and the thread end first into the notch of the bobbin case and then under the pressure spring of the bobbin case. Insert the bobbin case with the bobbin into the hook. To prevent the bobbin from falling out of the case, while being inserted into the hook, tilt the lock fixing the bobbin in the case. With your thumb, push the bobbin case in until you hear a short distinct sound. The correct position of the bobbin case in the hook signalled by this sound is very important, because otherwise a needle rupture or another breakdown could occur at the following machine start.

12. To catch the lower thread

Grasp lightly with your left hand the end of the upper thread without stretching it. With your right hand revolve the hand wheel towards you until the threaded needle reaches subsequently its bottom and top positions, thereby catching the lower thread. Draw then lightly the upper thread until the lower thread shows through the aperture provided in the throat plate. Lay the two thread ends in the direction behind the needle. While threaded, the machine may be started only after a bit of material has been inserted under the presser foot. Both when starting and when finishing the sewing, the thread take-up lever should be placed in its top position to avoid the risk that the upper thread in its top position to avoid the risk than the upper thread will thread out and possibly catch in the hook course.

13. Sewing - work proper

Insert the material to be sewn under the presser foot and switch on the electromotor. Start the machine by gradually depressing the right treadle. The sewing speed increases up to the maximum obtained with the treadle has reached its lowest position. By releasing the treadle, the clutch of the electromotor is disengaged, the electromotor braked, and the machine stopped. During the sewing, avoid pulling the material but guide it only. By pulling the material, you bend the needle with the risk of breaking it in case of a collisions with the edge of the needle aperture provided in the throat plate. Repeated collisions of this kind burr the needle aperture which, in its turn, causes thread ruptures. After the machine stop, set the needle to its top position, lift the presser foot, remove the sewn work from under it, and cut the two threads with scissors. After that, the machine is ready for stitching another seam.

To observe:

Having put the new machine in use do not charge it fully from the very beginning. During the first two or four weeks, when the machine is running-in, increase its speed gradually from about 3 000 stitches per min. and check carefully its running. Throughout this time, pay special attention to the machine lubrication. By keeping to these rules you will obtain a long service life and perfect precision of the machine even at its full performance.

II. INSTRUCTIONS FOR ADJUSTMENT OF MACHINE MECHANISMS

This section of the Manual describes adjustments of the type that can be carried out on the work site. Larger adjustments, requiring more time, should be carried out by a skilled sewing machine mechanician.

1. Stitch length adjustment (Fig. 7)

The stitch length can be steplessly adjusted by turning the knob (4) provided on the column of the machine arm, from zero to 5 mm. By turning it in the sense of the arrow "A" (i. e., to the right), you increase the stitch length, by turning it in the sense of the arrow "B" (i. e., to the left), you decrease it. For reverse stitching, depress either the left treadle, or the hand lever (1) towards the machine bed plate. When released, the lever automatically resumes its previous position and the machine restarts forward stitching.

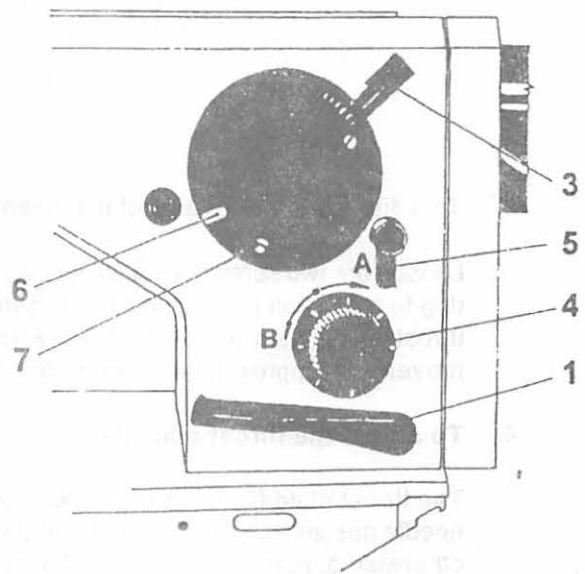

Fig. 7

2. To adjust the zigzag stitch width (Fig. 7)

Before any adjustment of the zigzag stitch width, the machine must be stopped with the needle outside the sewn work. The locking lever (5) must be turned to the left (anticlockwise) and held there until the adjustment is carried out, because its normal position, i. e., turned to the right, serves to lock the adjusted stitch width. The stitch width can be adjusted steplessly from zero to 10 mm by means of the lever (3) protruding over the cover of the zigzag stitch mechanism. By displacing the lever to the right, i. e., towards the hand wheel, you increase the zigzag stitch width up to the maximum, by displacing it to the left, you decrease it down to zero. Lock the adjusted stitch width by displacing the locking lever (5) to the right.

3. Thread tension adjustment

The tension of the upper and the lower thread must be so interrelated that the stitch binding place in the middle layer of the sewn material. To adjust the upper thread tension, turn the tensioner nut either to the right, i.e., clockwise, to increase the tension, or inversely, to decrease it. To adjust the lower thread tension, use the screw situated in the middle part of the pressure spring on the bobbin case. By turning the screw to the right you increase the pressure of the spring on the bobbin case and, consequently, the tension of the lower thread that passes between the spring and the bobbin case, and inversely. If the lower thread tension has been originally adjusted correctly, the adjustment of the upper thread tension by means of the tensioner nut will be sufficient, as a rule, to resort to the desired quality of stitching.

4. To adjust the feed-dog height above the throat plate (Fig. 8)

The height of the teeth of the feed-dog (A) should be adjusted to 0.8 - 1.2 mm, according to the kind of sewn material. To adjust it, loosen the screw (2) of the lifting lever (8) on the shaft (6), adjust the required height of the feed-dog teeth, and retighten the screw thoroughly with a screwdriver. To adjust the teeth horizontally, loosen the screw (1) of the feed lever (9) on the shaft (7) and adjust the rear part of the teeth by correspondingly adjusting the angular position of the eccentric pin (5), then retighten the screw (1).

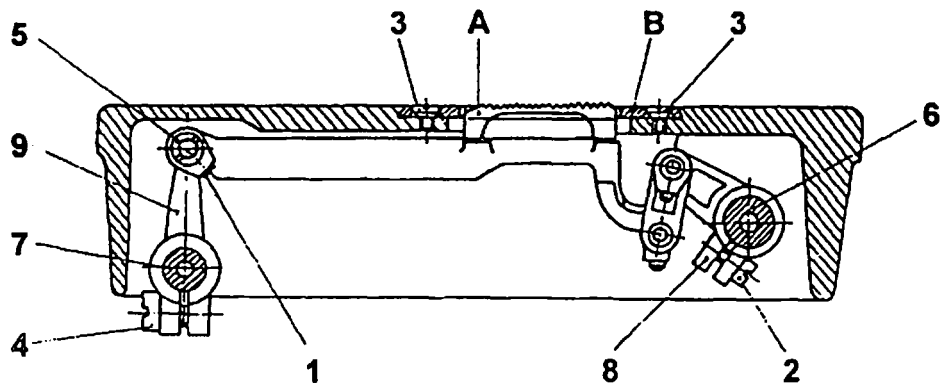

Fig. 8

5. To adjust the movement of the needle with respect to the feed-dog

Loosen the two screws of the lower belt wheel and turn by hand the hand wheel so as to set the feed-dog to a position in which the feeding movement ends and the feed-dog teeth are at a level with the throat plate, then rotate the hand wheel so as to position the needle point, during its downward movement, approximately 5 mm above the throat plate, and retighten the screws of the belt wheel.

6. To adjust the throat plate (Fig. 8)

The throat plate (B) must be properly seated and fixed by screws (3) in a position ensuring that the needle passes through the centre of the needle aperture. The needle aperture must not be burred or otherwise damaged since it would unfavourably affect the quality of stitching.

7. To adjust the presser bar pressure

The presser bar pressure is actuated by the adjusting screw located under the upper cover of the machine arm and accessible through a hole provided in the latter. By turning the adjusting screw to the right increase the pressure, by turning it to the left, decrease it. The pressure of the presser foot must be sufficient to ensure reliable and continuous feeding even at the top speed. On the correct adjustment of the presser bar pressure depends the uniformity of damage-free feeding as well as that of the stitch length.

8. To adjust in height the needle bar (Fig. 4)

The hook must be so interrelated with the needle that at the moment when the hook point begins to take up the upper thread loop, the upper edge of the needle ear is approximately 0.6 mm under the hook point, at the maximum stitch width and in the left position of the needle bar. If the needle bar height is not adequate to this requirement, loosen the respective screws, remove the front plate, loosen the screw (6) of the carrier (13) of the needle bar (10), adjust the needle bar correctly, and mount the front plate.

9. To adjust the hook course

Adjust the stitch width to zero and turn the hand wheel towards you until the needle bar reaches its bottom position and reascends by $2.8 + 0.2$ mm. In this position the hook point must lie in the needle axis, and the distance between the needle and hook must be 0.1 mm or less. If it is not the case remove the throat plate, loosen the screws, adjust the angular position of the hook on the hook shaft, retighten the screws, and mount the throat plate.

10. To adjust the hook holder (Fig. 2)

After the hook course adjustment, loosen the fixing screw and adjust the hook holder (2) so as to obtain a gap of approximately 0.7 mm between the holder lug and the bottom of the inner part of the hook.

11. To adjust the elliptical path of the feed-dog movement (Fig. 8)

If the machine is adjusted correctly the feed-dog describes an elliptical path both with forward and with reverse stitching. The adjustable eccentric is positioned by means of a pin in the aperture of the lower shaft and commands the length of feeding. Another eccentric, stationary and situated in front of the adjustable one, commands the correct interrelation between the major and the minor axe of the ellipse. The stationary eccentric is secured by two screws located in its collar. The eccentricity of the stationary eccentric is constant so that the height of the height of the ellipse remains the same regardless of the height adjustment of the feed-dog teeth. The adjustment should be carried out as follows: When the eccentricity of the adjustable eccentric equals zero (so that no feeding takes place) adjust the feed-dog holder with the feed-dog to the centre of the slot provided in the throat plate, having first loosened the screw (4) of the lever (9) on the feed shaft (7). Ensure that the feed-dog reaches its top height about the middle of the feed-dog movement.

12. To adjust the length of feeding

Loosen the screw of the lever on the pin of the reverse stitching hand lever, set the stitch length regulation knob to its zero position, adjust the traversable sleeve of the adjustable eccentric to a position corresponding to zero, retighten the screw of the lever, and check whether the feeding is equally long at forward and reverse stitching.

13. To adjust the hook opening (Fig. 9)

During the stitching, the gap between the sides of the groove provided in the inner part of the hook and the hook holder (7) is positively periodically opened by means of the opening lever (8) and of eccentric (6) to facilitate the movement of upper thread when leaving the hook. The eccentric is situated on the hook box at the end of the lower shaft. Adjust first the gap between the lug of the hook holder and the recess provided in the inner part of the hook, and simultaneously, the opening lever, i. e., the axial play between the lug of the opening lever and the face of the inner part of the hook. Screw out first the four screws (3) of the hook box cover (9), remove the cover, and take the lubrication inlay out of it. For adjustment, loosen the screw (1) fixing the position of the bobbin case (5) contacted by the pin (4) with the opening lever and adjust a gap of 0.8 mm between the lug of the opening lever and the lower surface of the hook by tapping lightly on the opening lever. At the same time, set the opening lever so as to produce a gap of 0.5 mm between the recess of the inner part and the hook holder required to let the thread pass. Having adjusted the opening lever, retighten the screw (1).

Before proceeding to carry out the adjustment, remove the throat plate. The timing of the opening lever with respect to the looper is best carried out only while the machine is being sewn off. Loosen the two screws (2) of the eccentric (6) and set its angular position on the lower shaft so as to time the opening of the inner part of the hook to begin prior to the moment when the upper thread begins to pass across the recess of the inner part of the hook and the lug of the hook holder. Check also the correct passage of the upper thread around the hook bottom, when the opening lever approaches the opening lug to open the passage around the inner part of the hook for the upper thread. The correct adjustment is best checked on the adjusting spring that must only slightly move while the thread passes freely. After the adjustment of the eccentric, retighten its screws, insert the lubrication inlay, and mount the cover of the hook box.

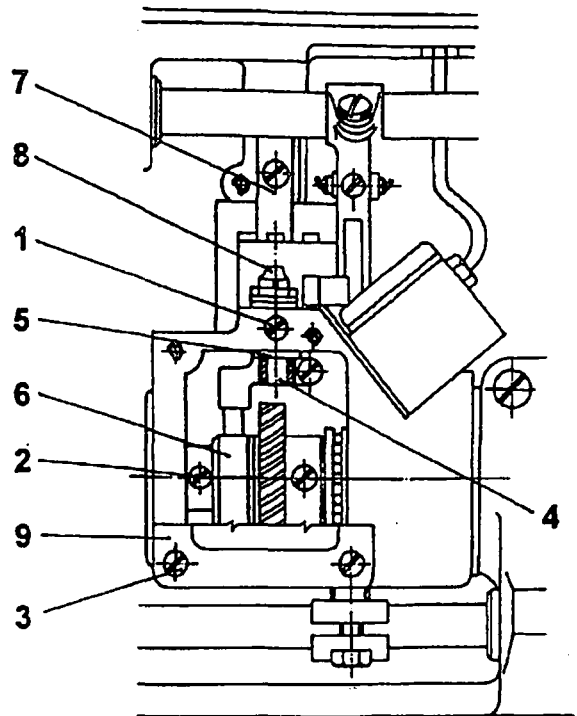

Fig. 9

14. To exchange the presser foot (Fig. 4)

To exchange the presser foot (1), first lift the presser bar (11) to its top position and lock it by the hand lifting lever (12). Lift also the needle to its top position, then loosen the attachment screw (5) of the presser foot together with the washer (7), and remove first the finger guard (9) and then the presser foot from the presser bar. To insert the presser foot, proceed inversely. Having fixed a new presser foot check, in its top position, whether the needle bar, during its movement, does not collide with the presser foot.

15. To dismantle and mount the drive belt (Fig. 10)

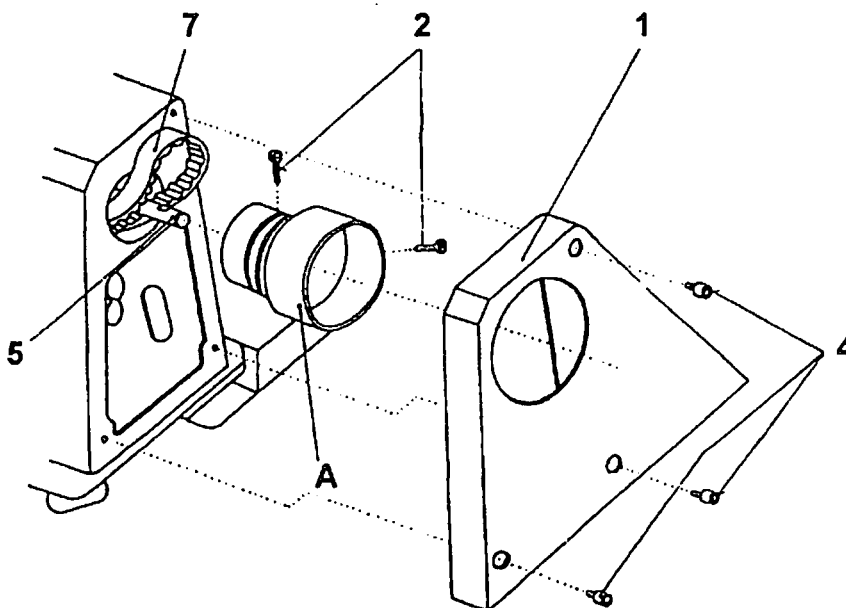

Fig. 10

Screw out the three screws (4), remove the belt guard (1) from the machine arm, tilt the machine head onto the supporting pin situated on the bed plate, take the V-belt out of the hand wheel groove, loosen the two screws (2), and remove the hand wheel from the machine arm and from the upper shaft (5). Pass the drive belt (7) through the aperture thus created in the machine arm, set it on the two belt wheels, and mount the complete hand wheel back on the upper shaft in such a position that the first screw (2), considered in the sense of rotation of the hand wheel, comes to sit on the small surface of the upper shaft, when tightened. Retighten the screws (2) of the hand wheel, tilt the machine back to its operational position, i.e., into the rim of the stand plate, and mount the belt guard.

16. To adjust the needle punches longitudinally into the centre of the slot of the throat plate (Fig. 4)

Adjust the zigzag stitch to the zero width and turn the handwheel until the needle bar with the needle reaches its bottom position. The needle should be in the centre of the throat plate slot both longitudinally and transversely. In case of longitudinal deviation (i.e., in the feed direction of sewn work) screw out the two screws of the front plate, remove the latter, loosen the securing screws (2 and 3), and finely adjust the angular position of the screws (4) both on the front and on the rear side of the machine arm so as to set the needle longitudinally into the centre of the front plate slot. Retighten the screws (2 and 3) and mount the front plate.

To observe:

When tightening the adjustment screws (4) for adjusting the needle position, do not tighten them completely but leave a minimum play between them and the needle bar holder in order not to obstruct the transverse movement of the needle bar holder required for the zigzag stitch.

Absence of play between the adjusting screws (4) and the needle bar holder involves the risk of damages to the needle bar mechanism.

17. To adjust the needle punches transversely into the centre of the slot of the throat plate (Tabs. 1, 3)

Adjust the zigzag stitch to the zero width and turn the hand wheel until the needle bar with the needle reaches its bottom position. In this position, the needle should be at the centre of the groove both in the transverse and in the longitudinal direction. If this is not the case, screw out the screw (26) and take the cover (25, Tab. 1) out of the front part of the machine arm, and the opposite plug, out of its rear part. Then loosen with a screwdriver the two screws (27, Tab. 3) and adjust the complete needle bar holder (4) so as to set the needle at the centre of the throat plate groove, and reinsert the cover and the plug. Check the needle punch position at the maximum stitch width and be sure that there is a play between the needle and the slot side in each lateral position of the needle. With zigzag stitch width adjusted at zero, the needle bar with the needle should react with no lateral movement to the hand wheel rotation. If it does react, the basic zero position of the zigzag stitch drive mechanism should be adjusted by an experienced sewing machine mechanic since such adjustment is rather extensive.

18. To adjust the needle bar lateral movement (Fig. 11)

If the machine is adjusted properly the needle bar begins to carry out its lateral movement, even at the maximum width of the zigzag stitch, only after the needle reascends by about 4 mm above the throat plate. For correct adjustment, screw out the four screws (6), remove the upper cover (1), loosen the screws (2) of the gear wheel (3) on the upper shaft (4), adjust the angular position of the handwheel accordingly, retighten the screws (2) thoroughly, and mount the upper cover (1) by screwing in the four screws (6).

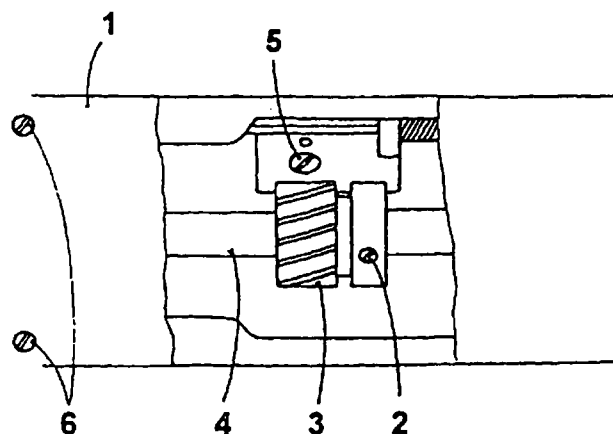

Fig. 11

19. To adjust the control force required for stepless adjustment of the zigzag stitch width (Figs. 12, 13)

For the stepless tilting of the zigzag stitch bracket, the inlay (10, Fig. 12) of the body of the zigzag stitch mechanism contains the braking roller (1) with the spring (5) and with the adjustment screw (8). Turning the screw to the right increases the pressure exerted on the roller and, consequently, the force required to adjust the stitch width. A mechanism actuated by the lever (7) serving to fix the adjusted stitch width must be turned to the left prior to proceeding to the stitch width adjustment which is carried out by the lever (2) whose extreme left position, defined by a stop, produces the zero zigzag stitch width that can be increased up to 10 mm by displacing the lever to the right. The number marking on the cover (1, Fig. 13) shows the approximative stitch width value at each lever position. To adjust the control force, first take the complete zigzag stitch mechanism out of the machine arm column. For this purpose, screw out the two screws (2) from the body of the mechanism, remove the cover (1), screw out the three attachment screws (3, Fig. 12) from the body of the zigzag stitch mechanism, then screw out the securing screw (3, Fig. 13) on the pin (5), remove the pin from the guiding (4), loosen the fixing lever (7, Fig. 12) and take the pin (6, Fig. 13) out of engagement, thus releasing the body of the zigzag stitch mechanism that can be then taken out of the machine arm. For the assembly, proceed inversely.

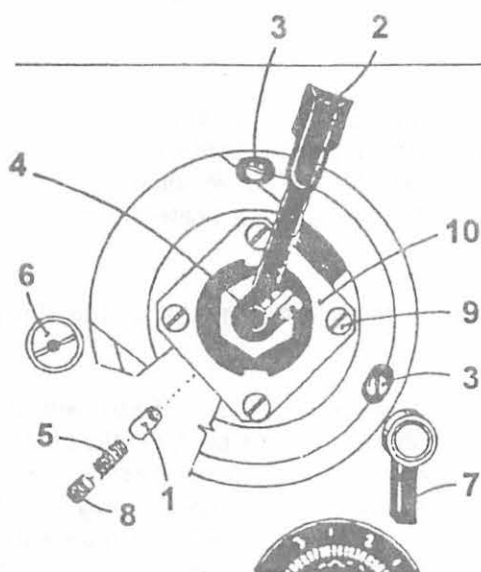

Fig. 12

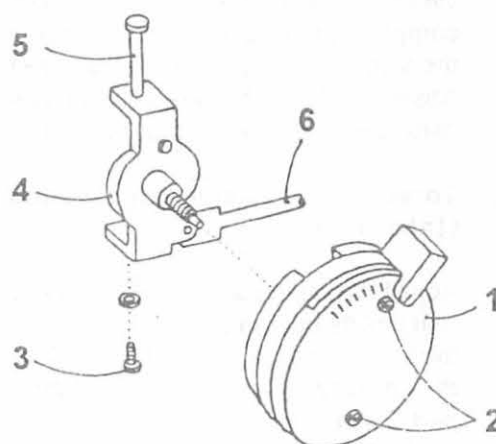

Fig. 13

20. To adjust the tooth play of the zigzag transmission mechanism (Figs. 11, 12)

The tooth play of the zigzag stitch transmission mechanism is actuated by the eccentric pin (6, Fig. 12). To adjust the tooth play, first screw out the four attachment screws (6, Fig. 11), remove the upper cover (1), and loosen the screw (5) located in the lug of the machine arm. By turning then the eccentric pin (6, Fig. 12) adjust the tooth play of the zigzag transmission mechanism, i. e., between the complete cam and the gear wheel (3, Fig. 11) mounted on the upper shaft (4), then lock the adjusted position by thoroughly tightening the screw (5).

21. To adjust the position of the needle bar with respect to that of the hook shaft (Figs. 14, 15)

After a substantial adjustment of machine mechanism should be checked the median (vertical) needle bar position with respect to that of the hook shaft. The hook shaft axis is displaced to the left of the needle bar axis. For adjustment, loosen the two screws (1, Fig. 14) ensuring the locking joint between the bed plate and the hook gear box. In correct position, the hook gear box is in direct contact with the lug of the bed plate. Lock the gear box position by tightening the two screws (1).

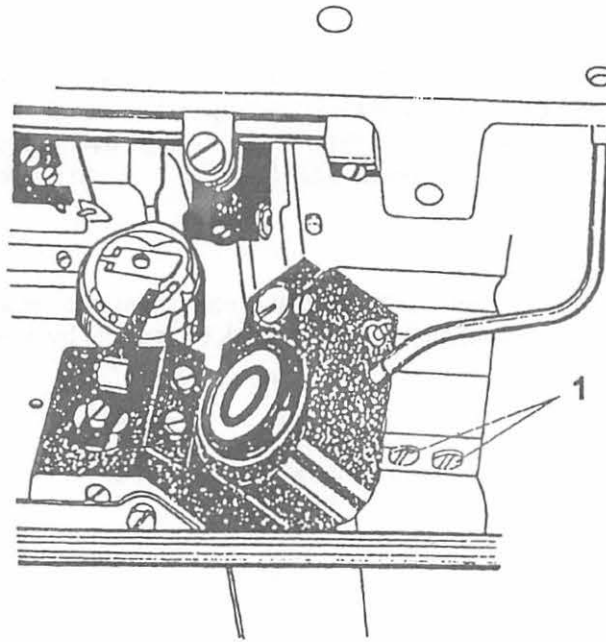

Fig. 14

To observe:

If the gear box of the hook has been removed be sure to reinstall it so as to ensure the parallelism of the hook shaft axis with the bed plate plane. Check the parallelism for instance by means of two shafts laid onto the upper surface of the bed plate and onto the worked surface of the gear box, and measure the value (B, Fig. 15).

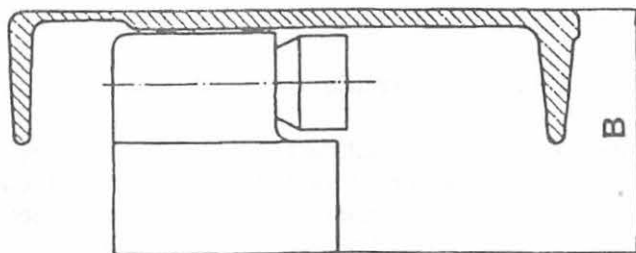

Fig. 15

22. To adjust the operation of the adjusting spring (Fig. 16)

Loosen the screw (1) and take the complete upper thread tensioner out of the machine arm. To adjust the tension of the adjusting spring (2), loosen the screw (3) on the bushing (4) and adjust the angular position of the pin (5). Turning the pin to the left will decrease the spring tension, and inversely. By this adjustment is adjusted the spring arm stroke as well. Displace the right-side sliding plate, sew a few stitches, and check the adjustment of the adjusting spring. With correct adjustment, the thread passing around the hook bottom shall produce a slight movement of the adjusting spring without being stretched.

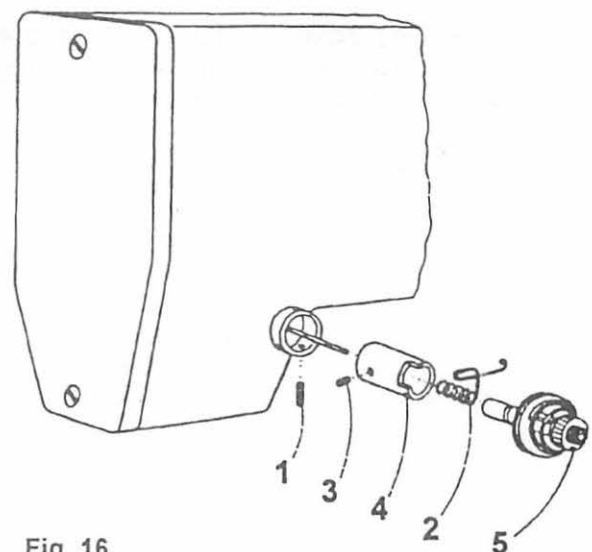

Fig. 16

23. Electrical equipment of machine

The machine is fitted with an electromotor mounted in the machine stand. The electrical equipment of the machine should be kept in good state according to the electrotechnical and security regulations. To change the sense of rotation of the electromotor change over the lead-in cable either at the plug or at the terminal board of the electromotor. In the latter case, do not omit first to take the plug of the lead-in cable out of the socket.



Warning I

Avoid any intervention into the electrical equipment of the machine but call in an electrician. Unqualified intervention involves the risk of accident by electric shock.

III. MAINTENANCE

1. Machine cleaning

Plain machine lines help to keep clean outer machine parts. From time to time, it is necessary to remove the waste between the feed-dog and the throat plate. Otherwise, the machine should be cleaned daily.



Warning I

Before proceeding to clean and lubricate the machine, be sure to switch off the main switch and hold your feet away from the machine stand treads in order to avoid accidental machine start by treadle actuation.

2. General overhaul and repair of the machine

Should be carried out once a year. The machine should be set out of operation, cleaned, dismantled, faulty pieces exchanged and due repairs carried out. The machine should be then assembled and tested. The electromotor and the electrical equipment should be inspected and tested. The general overhaul of the machine should be carried out so thoroughly as to enable the machine to run without major defects for another year.

3. To store the machine

After the machine has been set out of operation, it should be cleaned, inspected, and faulty pieces exchanged, if any. The machine should be then tested, coated with protective grease, and stored with all the tools and accessories.

IV. FAULTS AND HOW TO REMOVE THEM

Fault	Cause	Removal
a) Heavy machine run	The machine has been out of use for considerable time, dried oil and impurities deposited in the bearings.	Inject some drops of kerosene into all lubrication holes and on sliding surfaces and let the machine run rapidly so as to clean the lubrication holes in the bearings. Then oil the machine carefully (see par. 5, page 6).
b) Slow machine start	Insufficient belt tension.	Increase the belt tension by tilting the electromotor.
c) Upper thread breakage	<ol style="list-style-type: none">1. Slashed thread guides.2. Too sharp hook point.3. Faulty feeding.4. Faulty upper thread guiding or needle threading.5. Incorrect upper thread tension.6. Bad needle quality or bent needle.7. Thread size is inadequate to the thickness of sewn material.8. Machine considerably soiled.9. Thread wound on the hook.10. Thread is too thin or not strong enough.	<ol style="list-style-type: none">1. Ascertain and exchange them.2. Repair it.3. Adjust it see par. 5, page 12.4. Thread the upper thread correctly see par. 8, page 9.5. Adjust it see par. 3, page 12.6. Exchange the needle see par. 7, page 9.7. Use adequate thread.8. Unscrew the throat plate, clean the mechanism, and set the throat plate see par. 6, page 12.9. Remove the thread.10. Use adequate thread.
d) Lower thread breakage	<ol style="list-style-type: none">1. The thread is incorrectly threaded into the bobbin case.2. Thread is too thin or not strong enough.3. Thread is wound incorrectly on the bobbin.4. Damaged bobbin.5. Too sharp pressure spring on the bobbin case.	<ol style="list-style-type: none">1. Thread it correctly see par. 11, page 10.2. Use adequate thread.3. Wind it on the bobbin correctly.4. Exchange it.5. Exchange the spring.
e) Skipped stitches	<ol style="list-style-type: none">1. Needle inserted incorrectly.2. Blunt or bent needle.3. Slashed or broken hook point.4. Excessive needle aperture in the throat plate.	<ol style="list-style-type: none">1. Insert it correctly see par. 7, page 9.2. Exchange it see par. 7, page 9.3. Exchange the hook.4. Exchange the throat plate and set it correctly.

Fault	Cause	Removal
	<ul style="list-style-type: none"> 5. Broken adjusting spring for upper thread tension. 6. Needle bar positioned too high or too low. 7. Overturned hook, incorrect hook course. 8. Soiled hook mechanism. 	<ul style="list-style-type: none"> 5. Exchange the spring and adjust the upper thread tension see par. 3, page 12. 6. Adjust it see par. 8, page 13. 7. Adjust the hook course see par. 9, page 13. 8. Clean it with kerosene and oil it with oil.
f) Needle breakage	<ul style="list-style-type: none"> 1. Feed-dog positioned too high. 2. Faulty attendance - pulling the material. 3. Needle too thin with respect to material. 4. Needle inserted incorrectly. 5. Loosened throat plate. 6. Excessive upper thread tension. 	<ul style="list-style-type: none"> 1. Adjust it in height see par. 4, page 12. 2. Let the material pass freely. 3. Exchange the needle see par. 7, page 9. 4. Insert it correctly see par. 7, page 9. 5. Set the throat plate correctly see par. 6, page 12 and fix it by screws. 6. Adjust it see par. 3, page 12.
g) Heavy and irregular feeding	<ul style="list-style-type: none"> 1. Feed-dog positioned too low. 2. Worn-out feed-dog. 3. Clogged or blunt teeth of feed-dog. 4. Insufficient pressure of presser foot. 	<ul style="list-style-type: none"> 1. Adjust it in height see par. 4, page 12. 2. Exchange it. 3. Clean or exchange the feed-dog. 4. Increase the pressure see par. 7, page 12.
h) Stitch forming below sewn material	<ul style="list-style-type: none"> 1. Tensioner disks slashed by upper thread. 2. The thread does not pass smoothly around the looper or catches the bobbin case. 3. The upper thread is not thread between the tensioner disc. 4. Thread broken and caught between the tensioner disks. 5. Incorrect proportion between the upper and lower thread tensions. 	<ul style="list-style-type: none"> 1. Exchange them and adjust the upper thread tension see par. 3, page 12. 2. Clean the hook and adjust the bobbin case. 3. Thread it correctly. 4. Clean the thread tensioner and adjust it see par. 3, page 12. 5. Correct the proportion see par. 3, page 12 and check it from time to time.
i) Stitch forming above sewn material	<ul style="list-style-type: none"> 1. Damaged spring on the bobbin case, the lower thread is braked insufficiently. 	<ul style="list-style-type: none"> 1. Exchange the spring.

Fault	Cause	Removal
	2. Lower thread is not threaded under the spring of the bobbin case. 3. Lower thread broken and caught under the spring of the bobbin case. 4. Incorrect proportion between the upper and lower thread tensions. 5. Premature feeding.	2. Tread it correctly. 3. Remove the thread. 4. Correct the proportion see par. 3, page 12. 5. Adjust it see par. 5, page 12.
j) Locked hook	Thread rests caught in the hook.	Rotate the hand wheel in each direction regardless of the considerable resistance until the caught thread rests are cut to pieces. Remove them and start the unthreaded machine. Let it run for a period, then drip two or three drops of oil recommended in par. 5, page 6 onto the hook.

TABLES OF PARTS

tab. 1

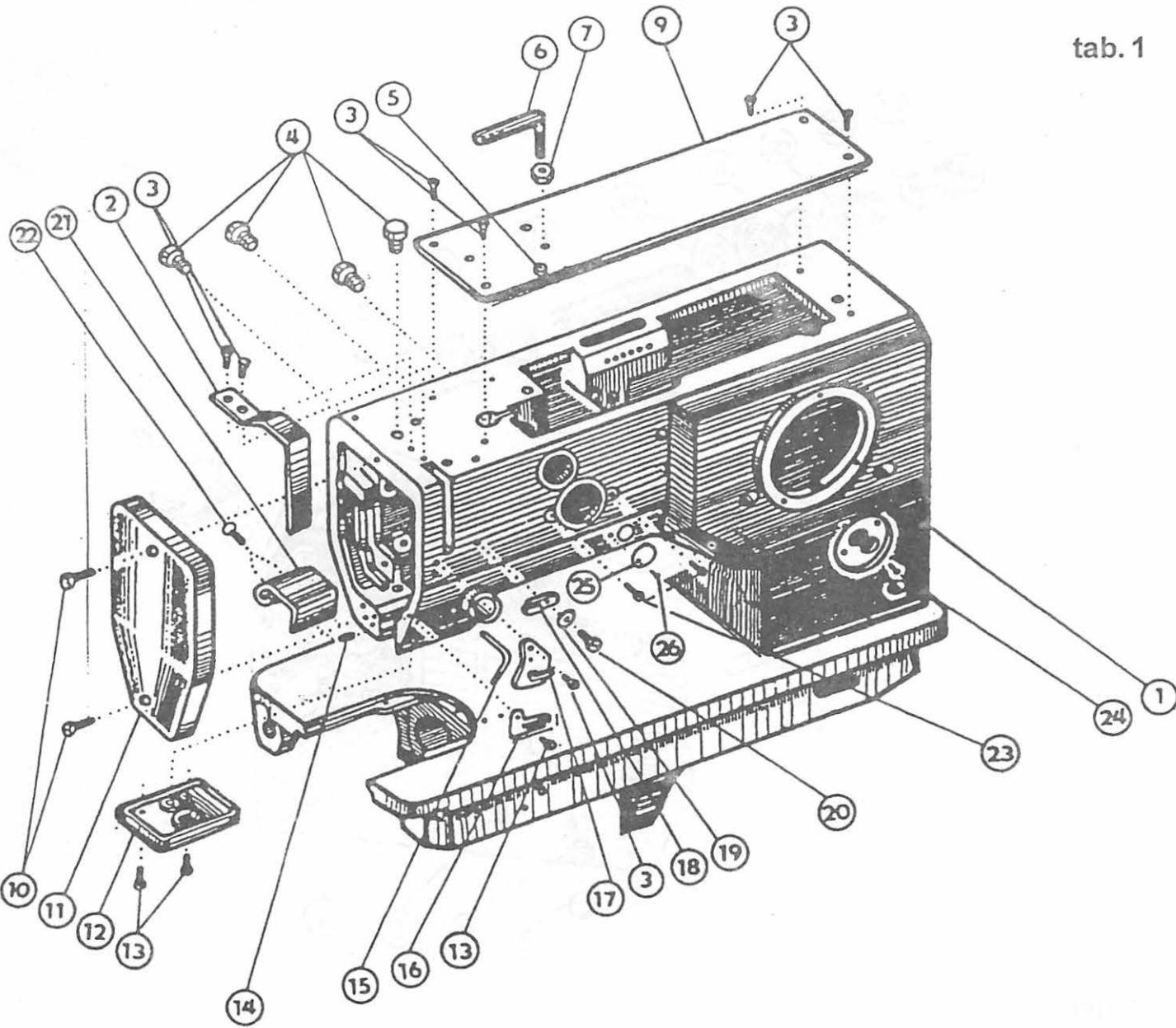

2	522 980	831 348
3	522 080	123 117
4	321 161	001 000
5	522 080	840 073
6	522 080	313 204
7	522 080	161 138
9	522 080	815 007
10	522 080	120 248
11	522 080	721 173
12	522 080	827 180
13	522 080	123 122
14	522 080	111 227
15	522 080	271 184
16	522 080	821 115
17	522 080	821 077
18	522 080	821 113
19	522 080	190 368
20	522 080	120 361
21	522 080	823 115
22	722 923	126 063
23	522 080	132 112
25	522 080	831 494
26	522 080	123 166

tab. 2

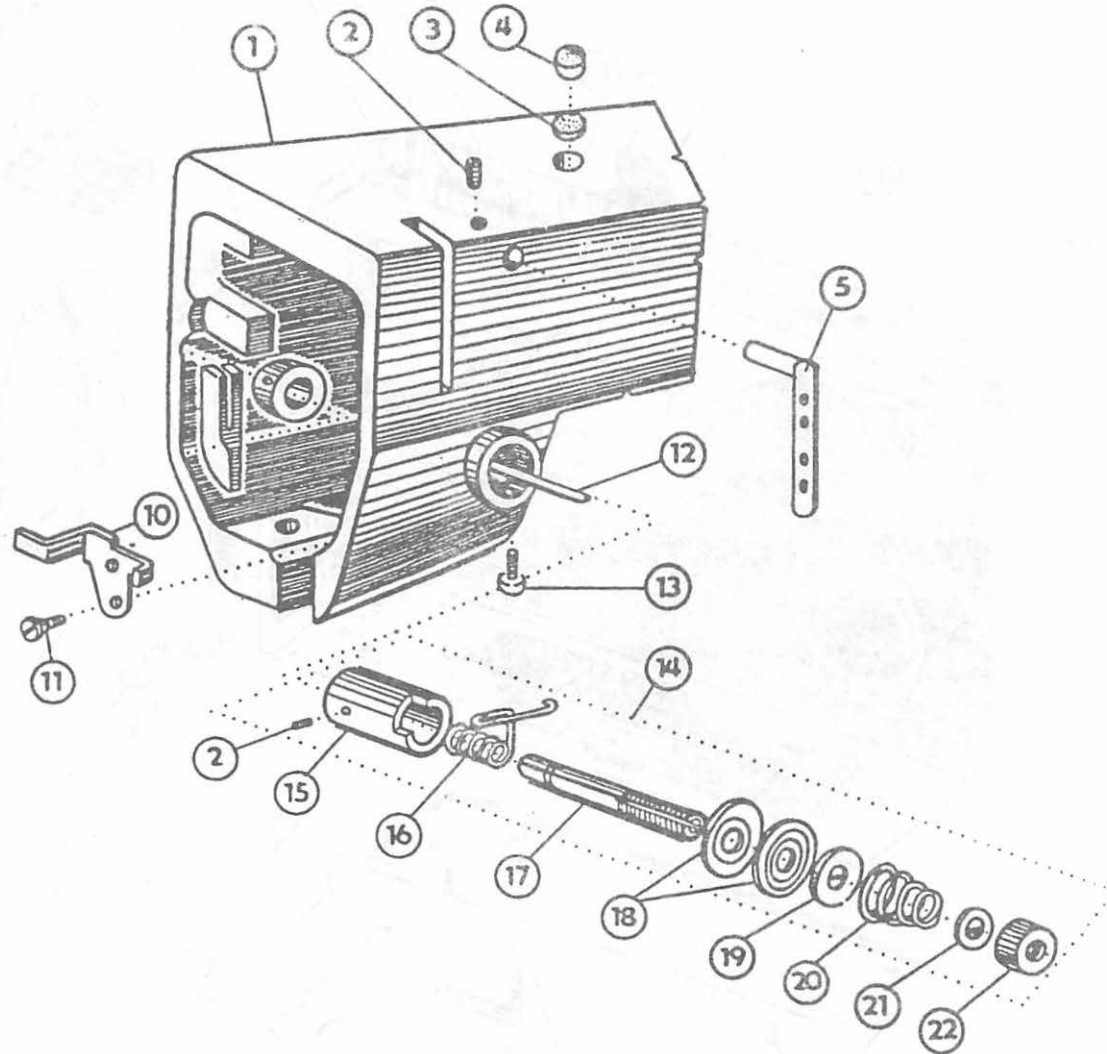

2	522 080	111 227
3	522 080	945 100
4	522 080	945 188
5	522 080	272 039
10	522 080	822 424
11	522 080	131 027
12	522 080	310 428
13	522 080	120 360
14	522 980	025 244
15	315 231	264 294
18	522 080	828 079
19	522 080	828 080
20	522 080	262 074
21	522 080	195 041
22	522 080	171 037

tab. 3

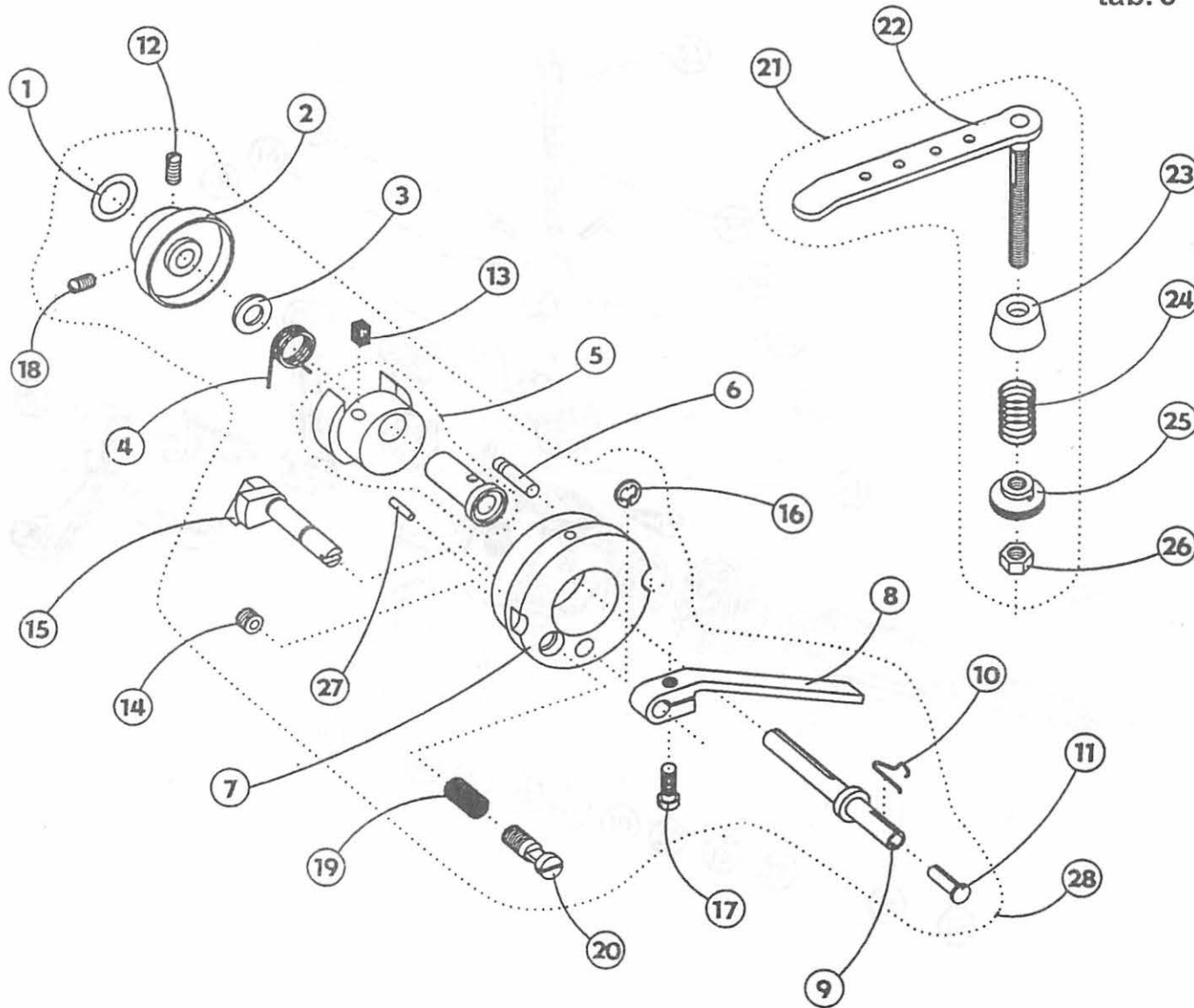

1	273 111	025 410
2	522 080	441 560
3	522 080	190 593
4	522 080	264 281
5	522 980	035 654
6	522 080	310 377
7	522 080	441 308
8	522 080	613 468
9	522 080	343 074
10	522 080	265 037
11	321 861	953 200
12	522 080	112 115
13	522 080	945 296
14	522 080	111 094
15	522 080	672 174
16	311 732	910 040
17	522 080	124 050
18	522 080	111 230
19	522 080	260 483
20	522 080	870 170
21	522 980	025 248
22	522 980	025 249
23	522 080	827 194
24	522 080	260 510
25	522 080	163 106
26	522 080	161 138
27	311 515	601 606
28	522 980	036 122

tab. 4

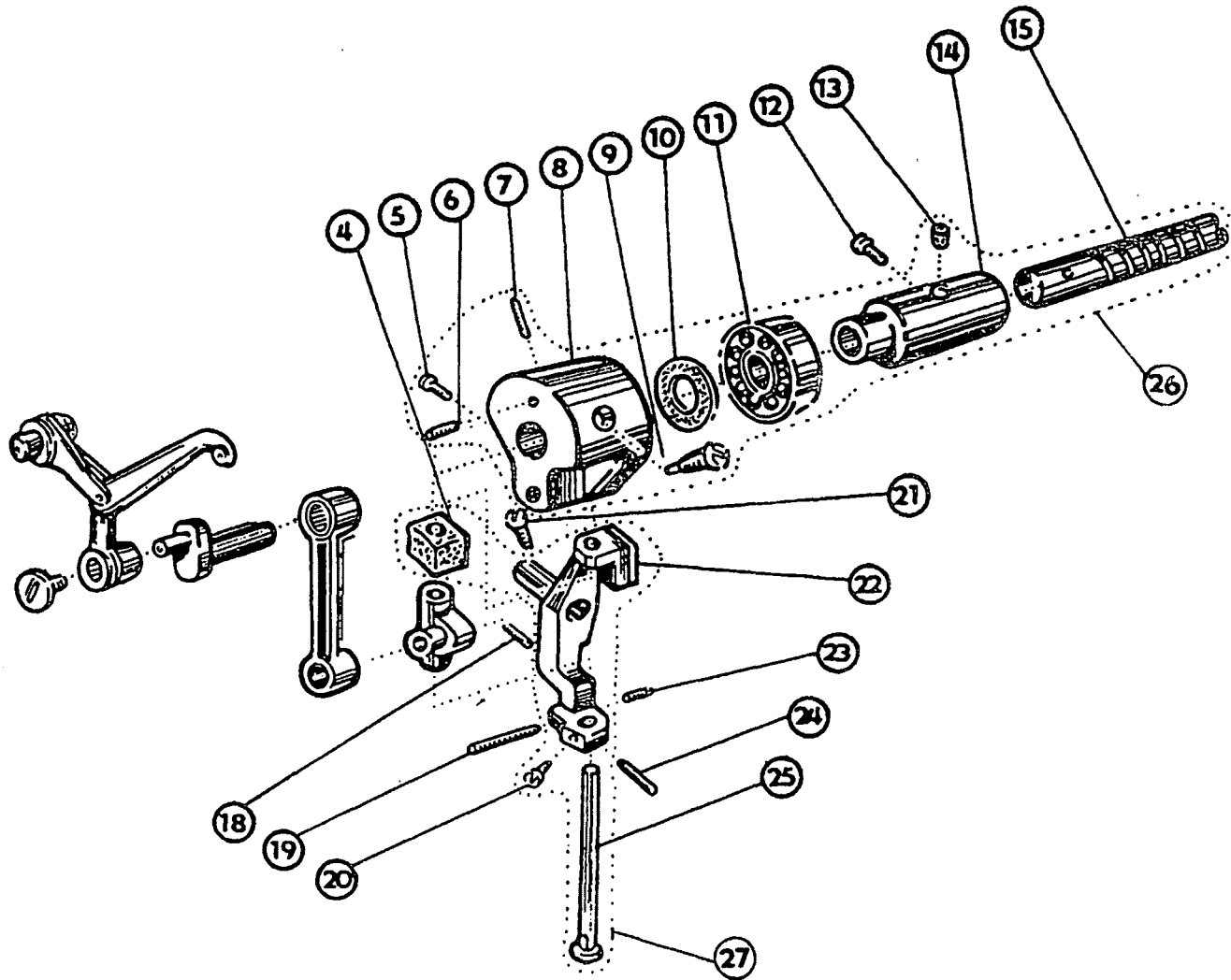

4	522 080	953 159
5	522 080	122 007
6	522 080	111 238
7	522 080	112 015
9	522 080	138 009
12	522 080	120 006
13	522 080	953 139
18	522 080	111 273
19	522 080	111 126
20	522 080	120 216
21	522 080	120 220
23	522 080	111 214
24	522 080	111 295
26	522 980	043 343
27	522 980	035 318

tab. 5

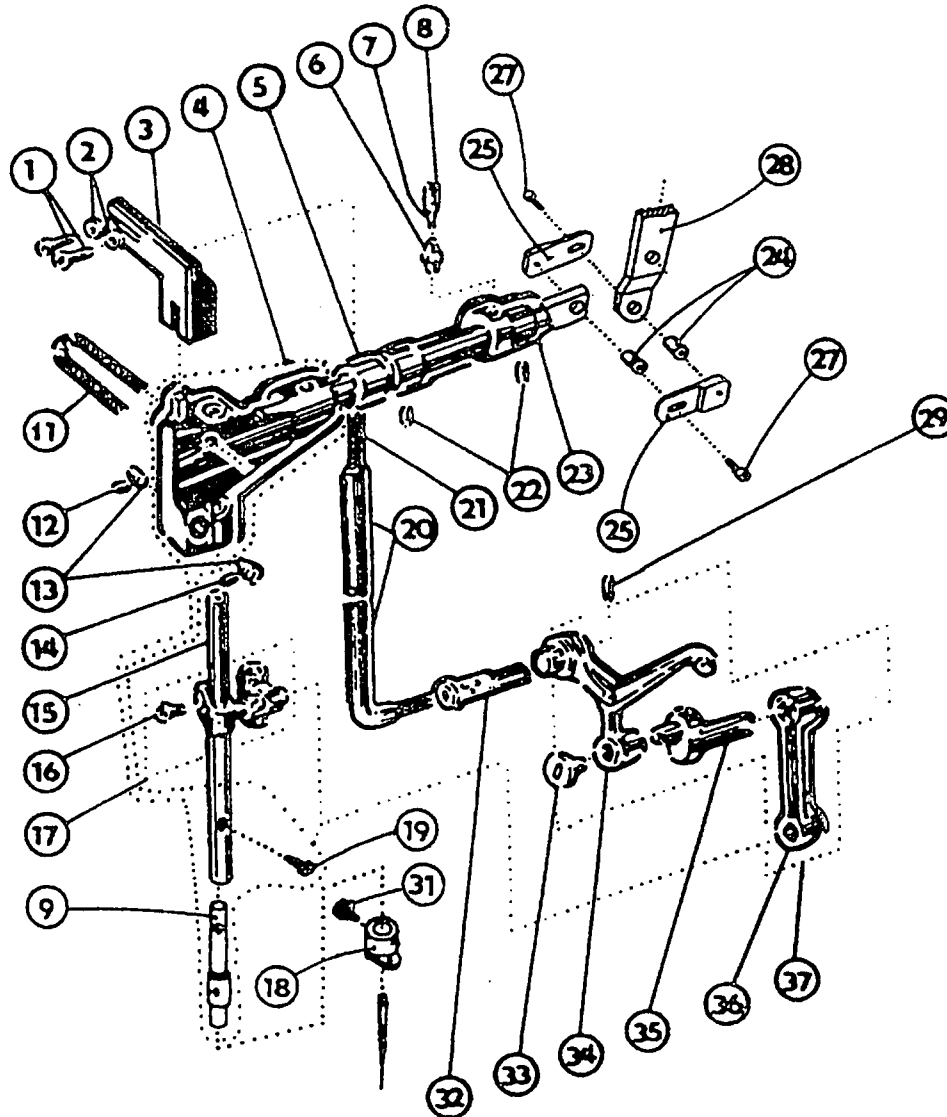

1	522 080	120 276
2	522 080	190 353
3	522 080	646 104
4	522 980	021 394
5	522 080	413 311
6	522 080	424 051
7	708 420	002 105
	ø 1,5 x 250 mm	
8	283 366	002 001
	ø 3,5/ø 4,8 x 190 mm	
9	522 080	394 167
11	708 420	002 105
	ø 1,5 x 80 mm	
12	522 080	111 229
13	522 080	113 115
14	522 080	111 248
15	522 080	391 176
16	522 080	124 050
17	522 980	035 499
18	522 080	627 170
19	522 080	136 082
20	283 366	002 001
	ø 3,5/ø 4,8 x 70 mm	
21	708 420	130 003
	ø 3 x 250 mm	
22	522 080	111 122
23	522 080	421 341
24	522 080	410 595
25	522 080	648 132
27	522 080	120 589
28	522 080	613 519
29	522 080	112 014
31	522 080	135 029
32	522 080	328 005
33	522 080	120 062
37	522 980	044 727

tab. 6

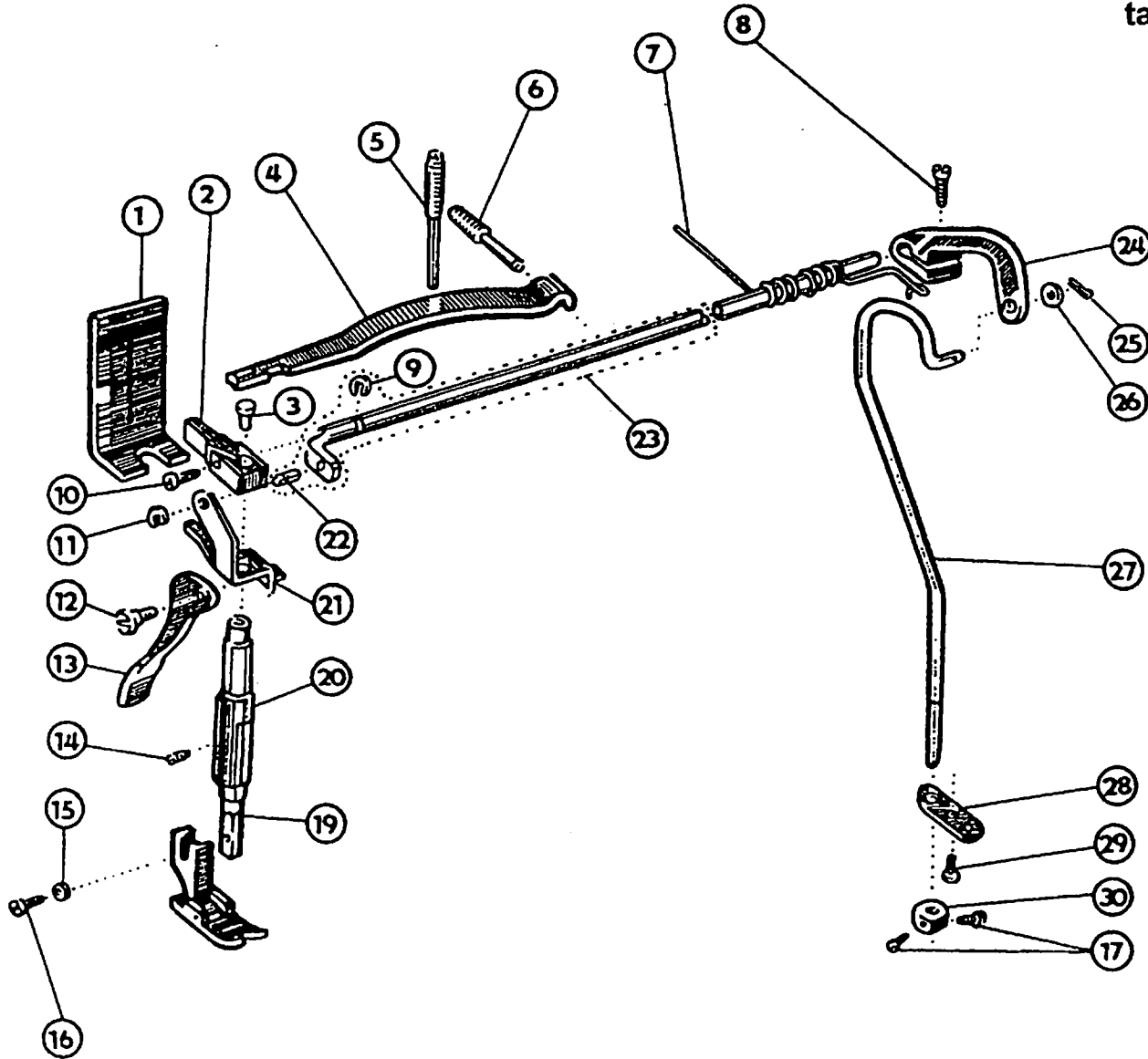

1	522 080	945 317
2	522 080	623 249
3	522 080	326 213
4	522 080	283 152
5	522 080	113 122
6	522 080	113 123
7	522 080	264 296
8	522 080	120 221
9	311 732	910 060
10	522 080	120 543
11	311 732	910 040
12	522 080	136 023
13	522 080	615 021
14	522 080	112 014
15	522 080	190 554
16	522 080	120 239
17	522 080	120 050
19	522 080	392 105
20	522 080	421 330
21	522 080	839 215
23	522 980	044 713
24	522 080	613 453
25	522 080	271 337
26	522 080	190 346
27	522 080	383 168
28	522 080	814 014
29	522 080	120 217
30	522 080	436 331

tab. 7

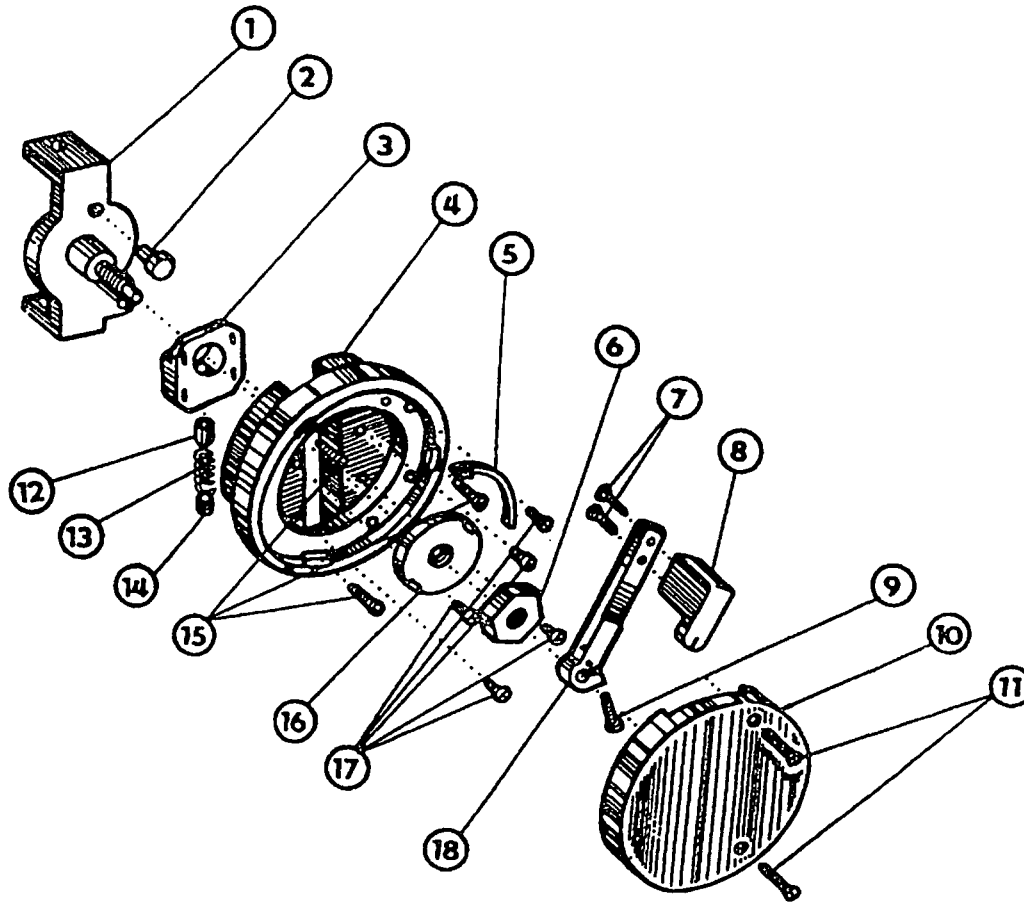

1	522 080	646 027
2	522 080	322 247
3	522 080	646 120
4	522 080	442 530
5	522 080	839 010
6	522 080	161 236
7	522 080	126 101
8	522 080	952 251
9	522 080	120 543
10	522 080	954 048
11	522 080	123 130
12	321 841	020 000
13	522 080	260 139
14	522 080	111 099
15	522 080	120 276
16	522 080	174 066
17	522 080	120 219
18	522 080	613 472

tab. 8

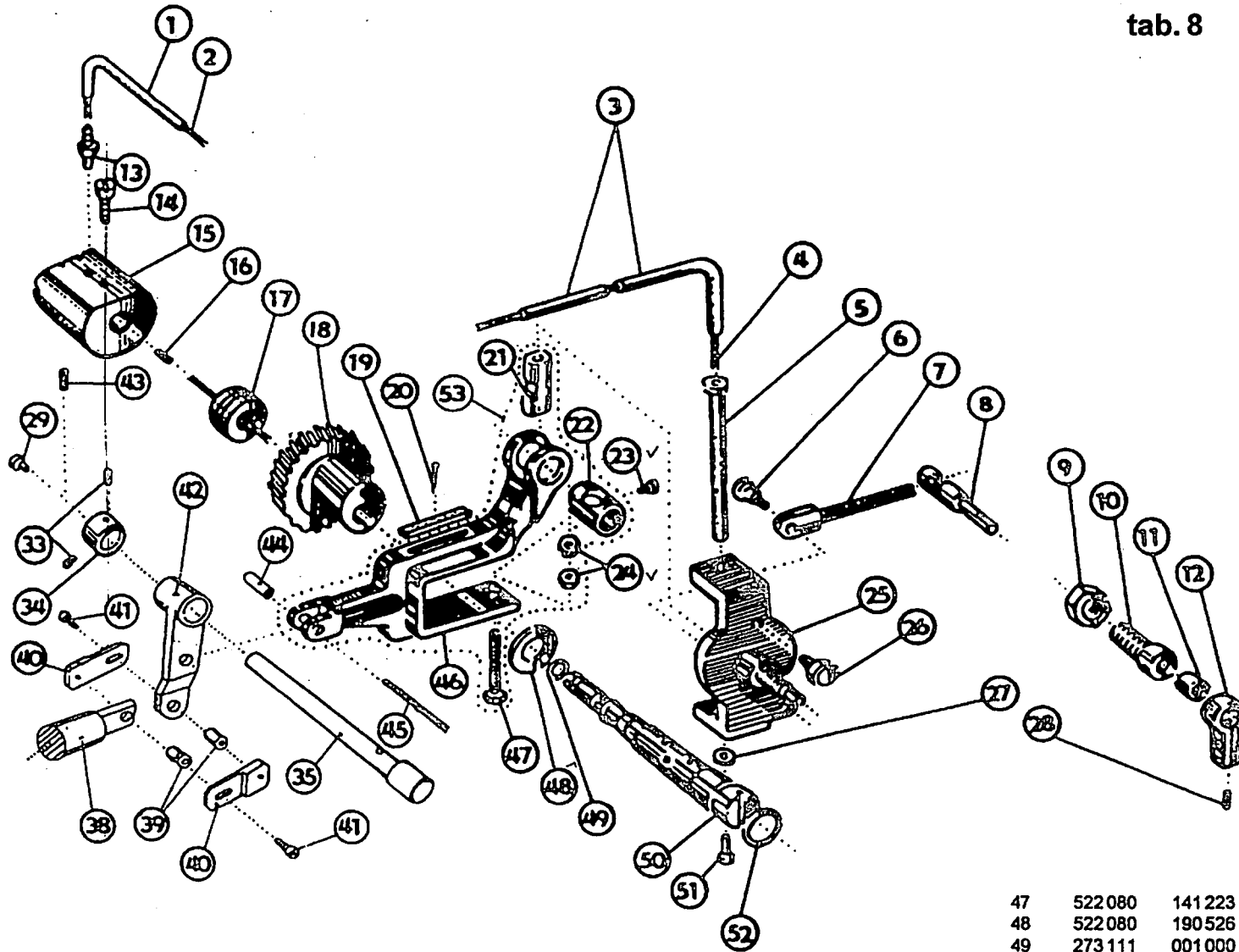

47	522 080	141 223
48	522 080	190 526
49	273 111	001 000
50	522 080	335 105
51	522 080	120 221
52	273 111	007 000
53	522 980	024 263

1	283 366	002 001
	ø 3,5/ø 4,8x100 mm	
2	708 420	130 002
	ø 2 x 140 mm	
3	283 366	002 001
	ø 3,5/ø 4,8x210 mm	
4	708 420	130 002
	ø 2 x 270 mm	
5	522 080	335 101
6	522 080	131 391
7	522 080	152 099
8	522 080	334 097
9	522 080	161 237
10	522 080	422 184
11	522 080	163 093
12	522 080	612 342
13	522 080	424 051
14	522 080	120 233
16	522 080	951 327
17	324 311	010 000
18	522 980	035 598
19	522 080	945 326
20	738 923	002 000
23	522 080	120 281
24	522 080	161 233
25	522 080	646 027
26	522 080	322 247
27	522 080	190 359
28	522 080	112 101
29	425 111	041 000
33	522 080	112 013
34	522 080	436 000
35	522 080	320 289
38	522 980	021 394
39	522 080	410 595
40	522 080	648 132
41	522 080	120 589
42	522 080	613 519
43	522 080	132 203
44	522 080	318 210
45	522 080	130 002
	ø 2 x 150 mm	

tab. 9

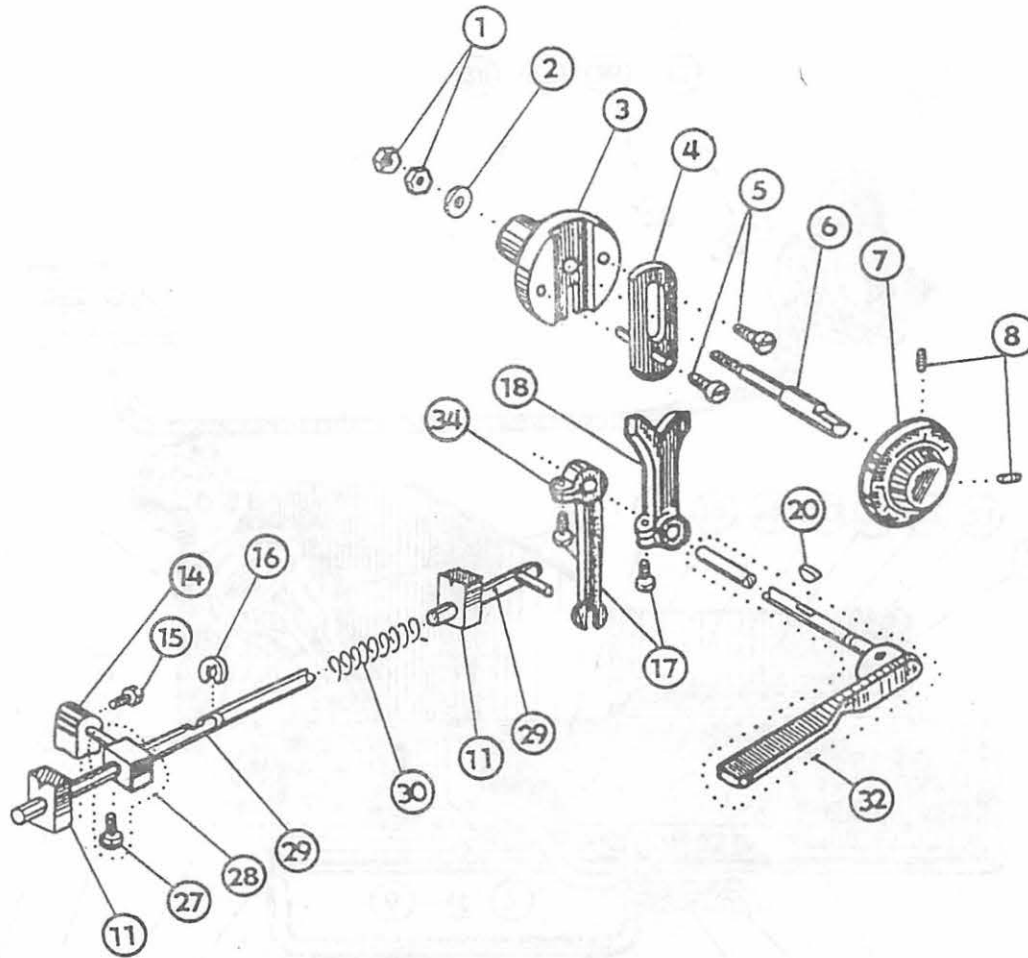

1	522 080	161 142
2	522 080	192 061
3	522 080	441 187
4	522 980	049 785
5	522 080	120 246
6	522 080	342 258
7	522 080	233 031
8	522 080	112 013
14	522 080	627 023
15	522 080	141 102
16	311 732	910 070
17	522 080	120 221
18	522 080	613 328
20	311 728	502 537
27	522 080	120 227
28	522 980	022 126
29	522 980	043 301
30	522 080	260 383
32	522 980	044 714
34	522 080	613 373

tab. 10

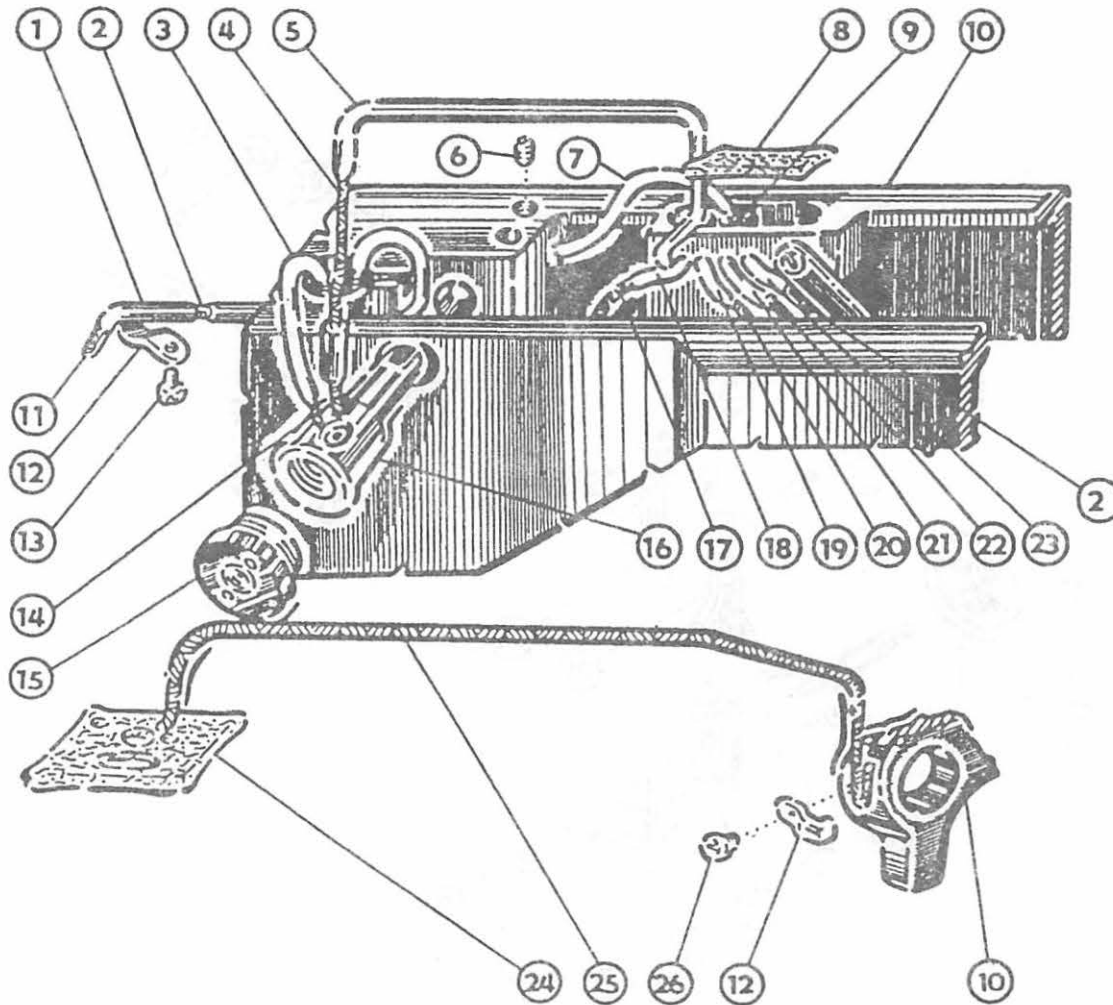

1	283 366	002 001
	ø 3,5/ø 4,8 x 65 mm	
2	708 420	130 002
	ø 2 x 140 mm	
3	283 366	002 001
	ø 3,5/ø 4,8 x 75 mm	
4	708 420	130 003
	ø 3 x 300 mm	
5	283 366	002 001
	ø 3,5/ø 4,8 x 150 mm	
6	522 080	111 245
7	283 366	002 001
	ø 3,5/ø 4,8 x 200 mm	
8	522 080	945 316
9	708 420	130 002
	ø 2 x 250 mm	
11	522 080	945 180
12	522 080	824 095
13	522 080	120 245
14	708 420	130 003
	ø 3 x 110 mm	
15	821 891	001 000
16	522 080	441 313
17	708 420	130 002
	ø 2 x 320 mm	
18	283 366	002 001
	ø 3,5/ø 4,8 x 250 mm	
19	283 366	002 001
	ø 3,5/ø 4,8 x 210 mm	
20	708 420	130 002
	ø 2 x 270 mm	
21	283 366	002 001
	ø 3,5/ø 4,8 x 90 mm	
22	708 420	130 002
	ø 2 x 130 mm	
23	283 366	002 001
	ø 3,5/ø 4,8 x 100 mm	
24	522 080	945 286
25	708 420	130 005
	ø 5 x 640 mm	
26	522 080	120 216

tab. 11

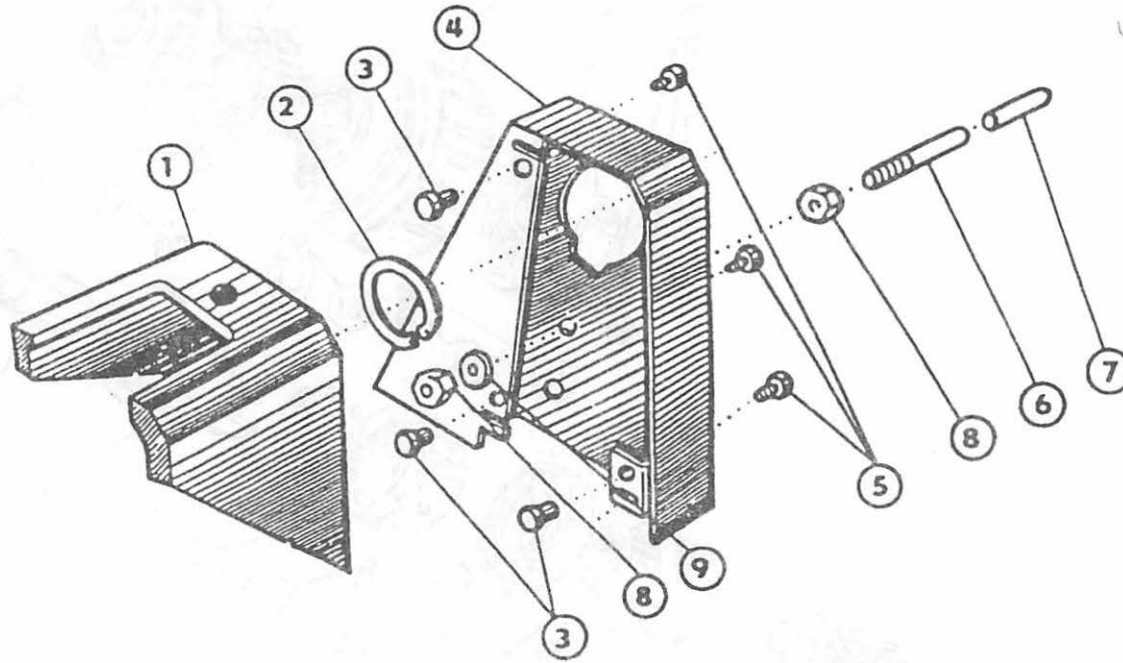

2	311 733	100 620
3	273 199	005 000
4	522 980	041 162
5	522 080	120 346
6	522 080	316 096
7	283 362	003 001
	ø 5/6 x 25 mm	
8	522 080	161 151
9	522 080	191 112

tab. 12

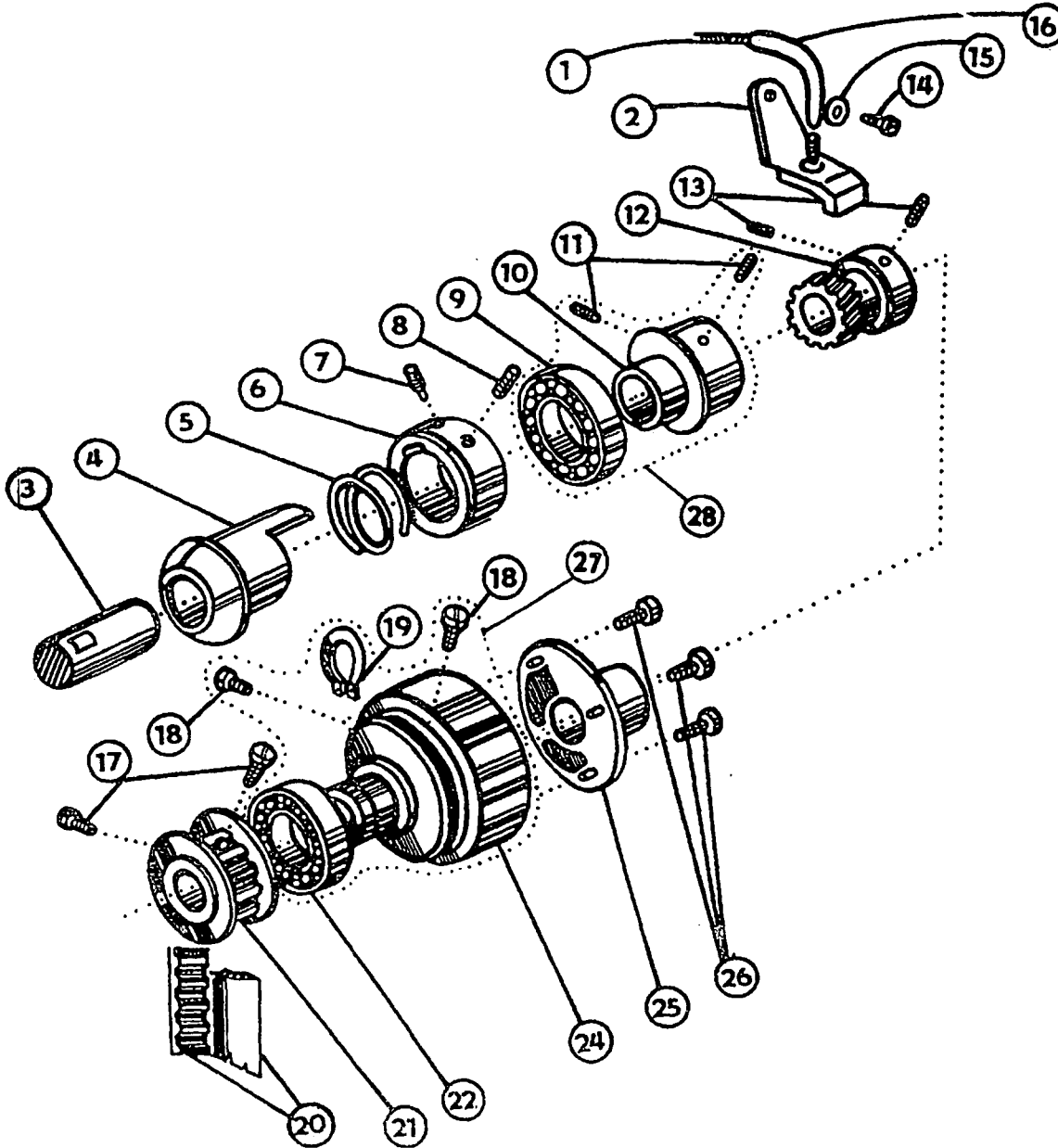

1	708 420	130 002
	ø 2 x 130 mm	
2	522 980	041 176
4	522 980	441 541
5	522 080	260 467
6	522 080	436 338
7	522 080	113 115
8	522 080	112 013
11	522 080	111 225
12	522 980	045 330
13	522 080	111 343
14	522 080	120 259
15	522 080	190 359
16	283 366	002 001
	ø 3,5/ø 4,8 x 90 mm	
17	522 080	122 029
18	522 080	120 006
19	311 733	000 300
20	272 213	011 015
21	522 980	045 314
25	522 080	442 548
26	522 080	120 252
27	522 980	045 301
28	522 980	035 849

tab. 13

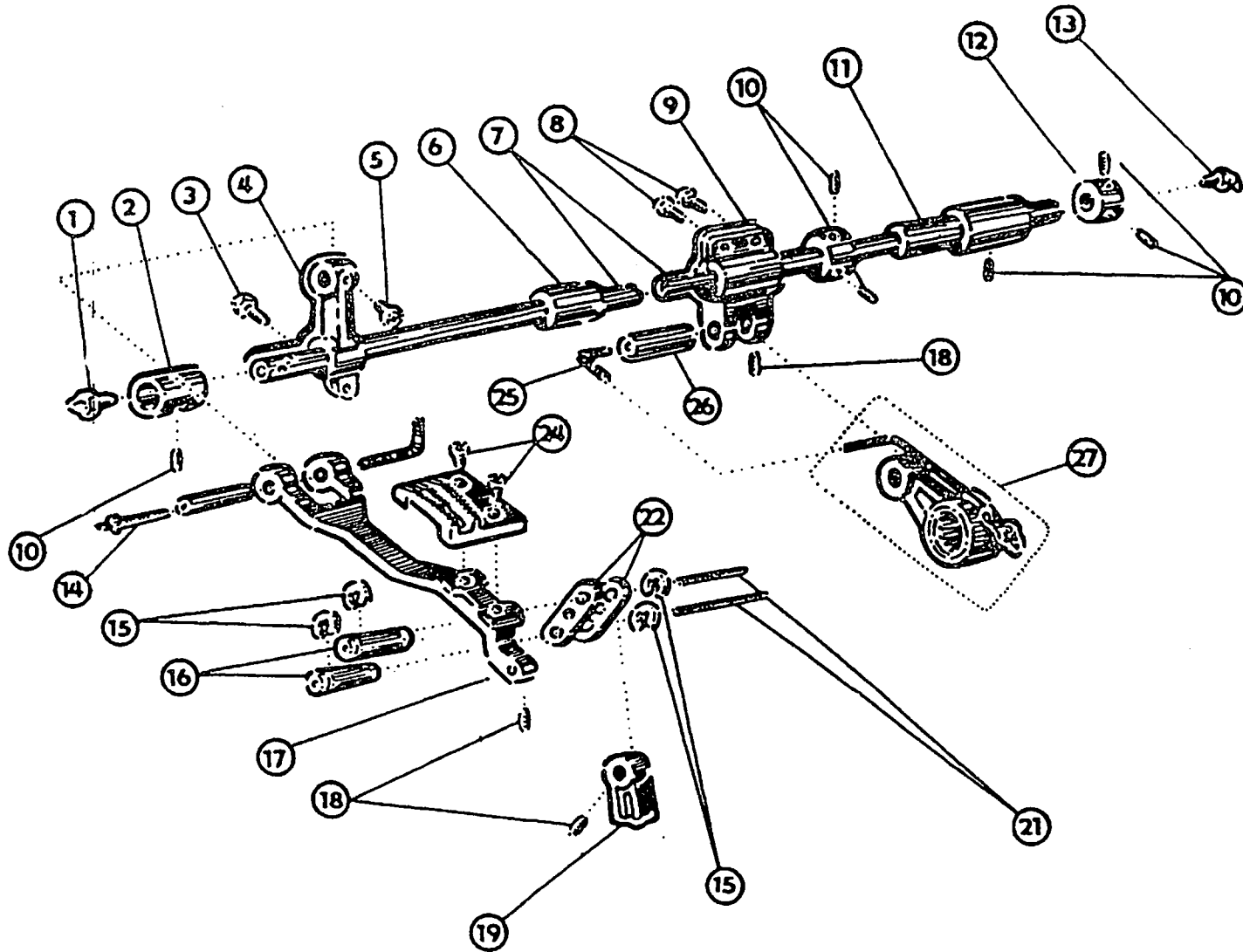

1	425 111	041 000
2	522 080	413 252
3	522 080	141 133
4	522 080	613 495
5	522 080	124 050
6	522 080	410 532
7	522 080	345 067
8	522 080	120 229
9	522 080	613 216
10	522 080	112 013
11	522 080	412 193
12	522 080	436 000
13	425 111	061 000
14	708 420	130 002
	ø 2 x 160 mm	
15	311 732	910 050
16	522 080	318 144
17	522 080	622 092
18	522 080	111 227
19	522 080	613 195
21	708 420	130 002
	ø 2 x 60 mm	
22	522 080	612 109
23	522 080	338 069
24	522 080	121 157
25	708 420	002 105
	ø 1,5 x 350 mm	
26	522 080	344 035
27	522 980	044 045

tab. 14

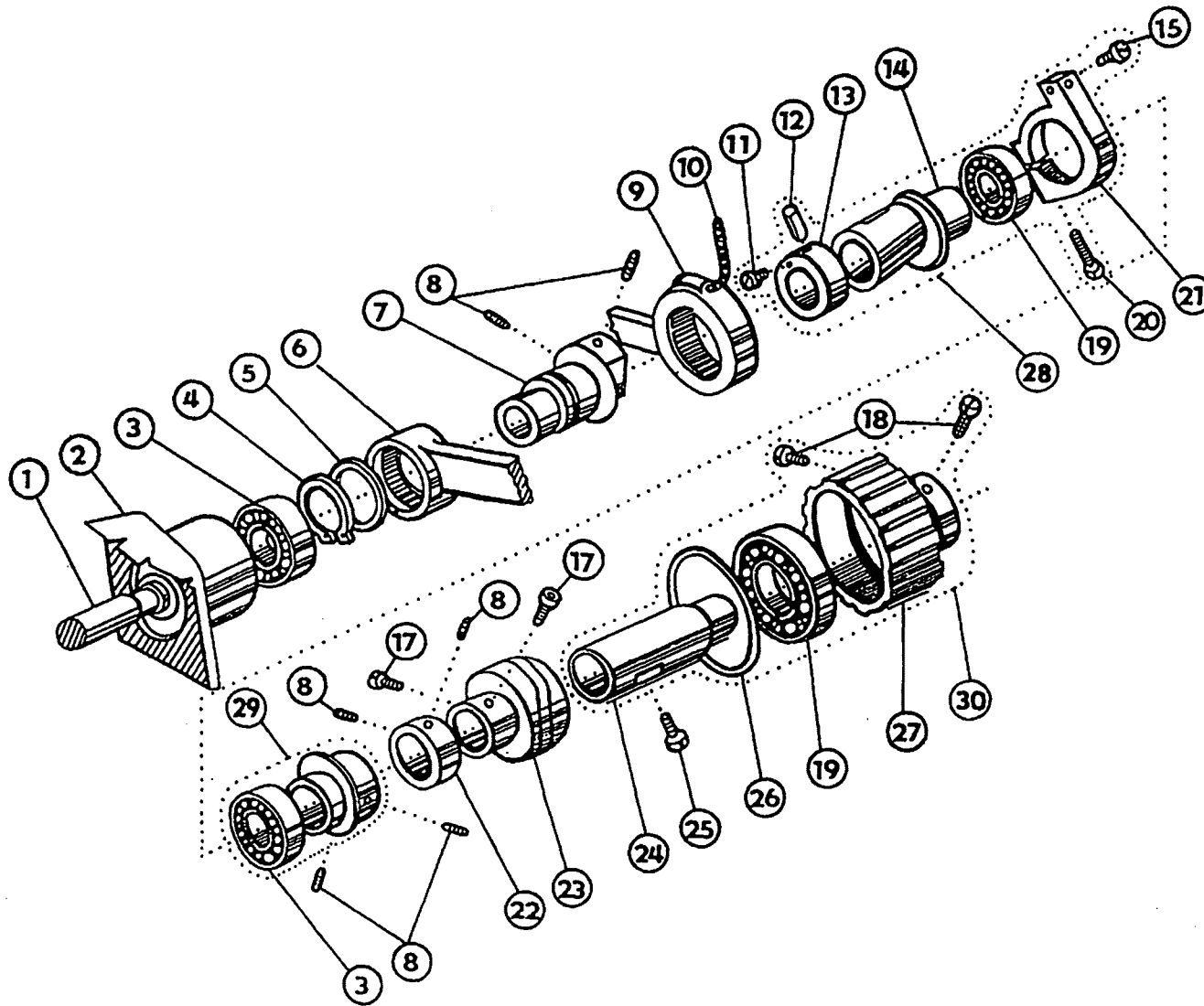

1	522 080	342 243
2	522 080	724 134
3	324 165	020 093
4	311 733	000 108
5	522 080	814 338
6	522 080	630 248
7	522 080	671 152
8	522 080	111 343
9	522 980	044 045
10	708 420	002 105
	ø 1,5 x 350 mm	
11	522 080	141 088
12	522 080	318 103
15	522 080	141 102
17	522 080	627 023
18	522 080	122 029
21	522 080	122 031
22	522 080	271 062
28	522 980	035 422
29	522 980	035 420
30	522 980	045 231

tab. 15

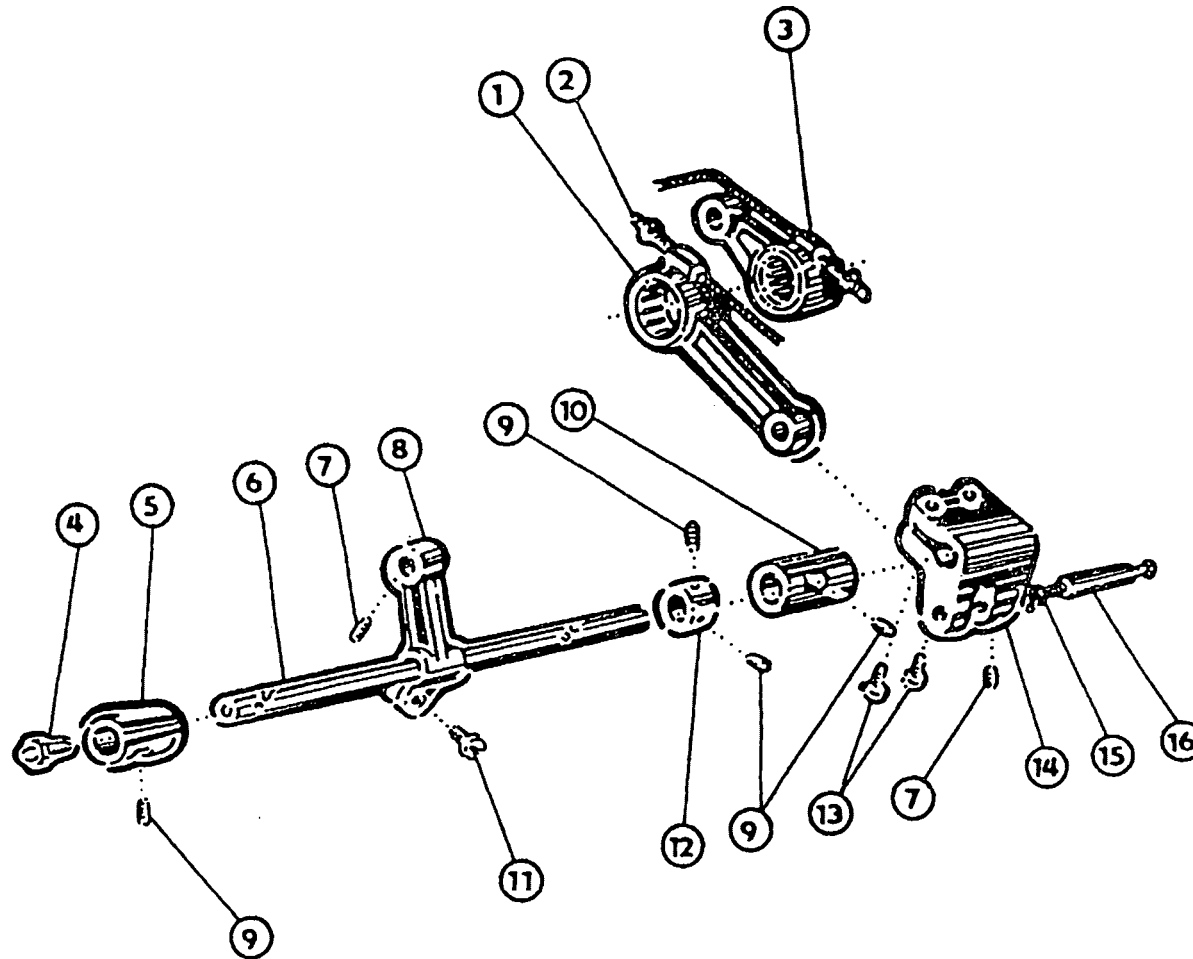

1	522 080	630 248
2	708 420	002 105
	ø 1,5 x 220 mm	
3	522 980	044 045
4	425 111	041 000
5	522 080	413 251
6	522 080	345 065
7	522 080	111 227
8	522 080	613 195
9	522 080	112 013
10	522 080	410 538
11	522 080	120 229
12	522 080	436 000
13	522 080	120 231
14	522 080	613 152
15	708 420	130 002
	ø 2 x 60 mm	
16	522 080	344 035

tab. 16

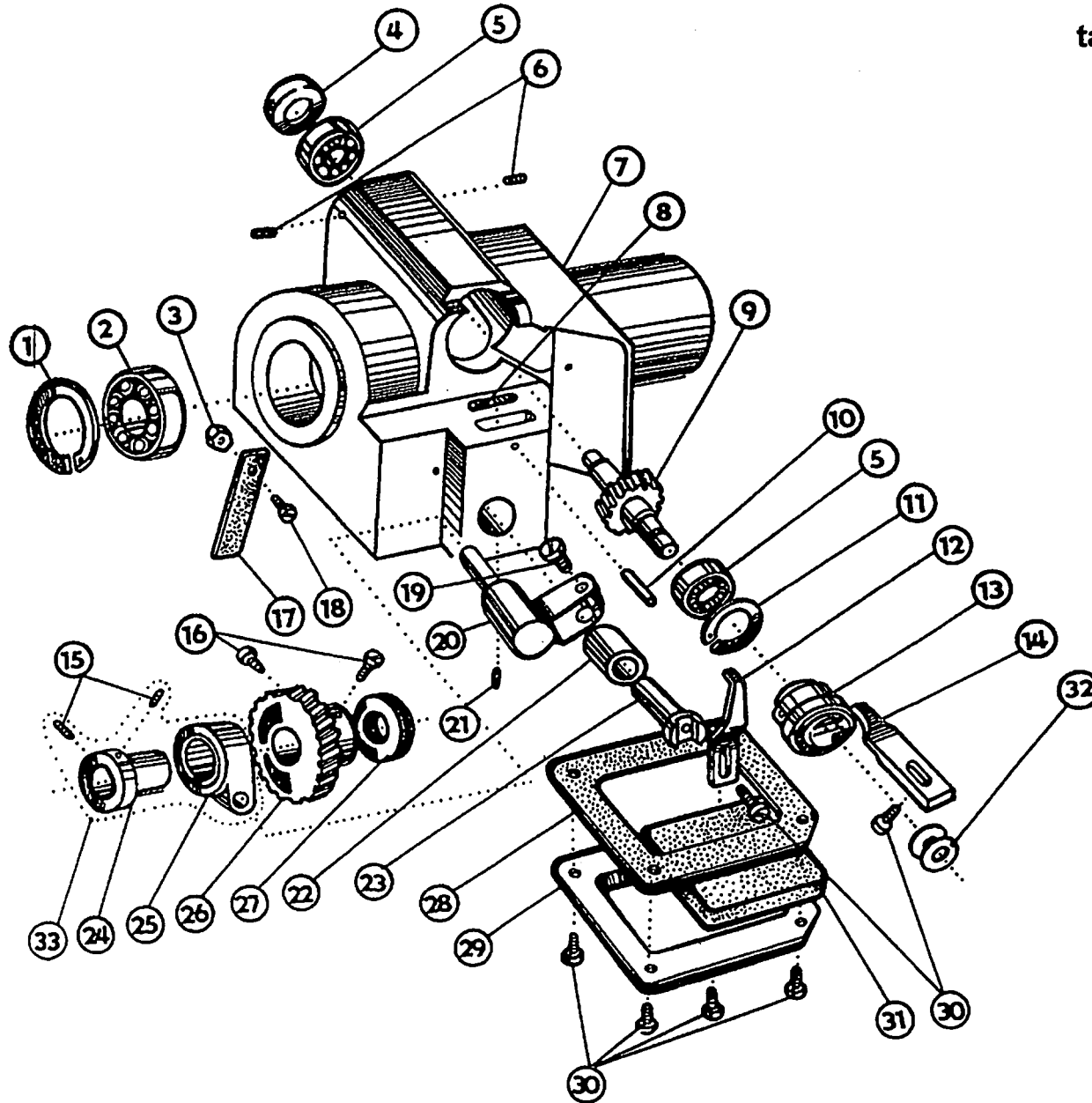

1	311 733	100 260
2	324 152	920 796
4	522 080	441 287
5	324 155	910 093
6	522 080	111 219
7	522 080	724 134
8	708 420	130 002
9	522 080	552 168
10	311 515	601 612
11	311 733	100 220
12	522 080	825 740
13	522 980	008 251
14	522 080	825 744
15	522 080	111 343
16	522 080	122 007
17	522 080	945 283
18	522 080	120 601
19	522 080	120 226
20	522 080	613 466
21	522 080	111 094
22	522 080	410 530
23	522 080	323 155
26	522 080	552 167
27	324 311	010 000
28	522 080	990 134
29	522 080	827 179
30	522 080	120 246
31	522 080	945 285
32	522 080	685 051
33	522 980	035 406

tab. 17

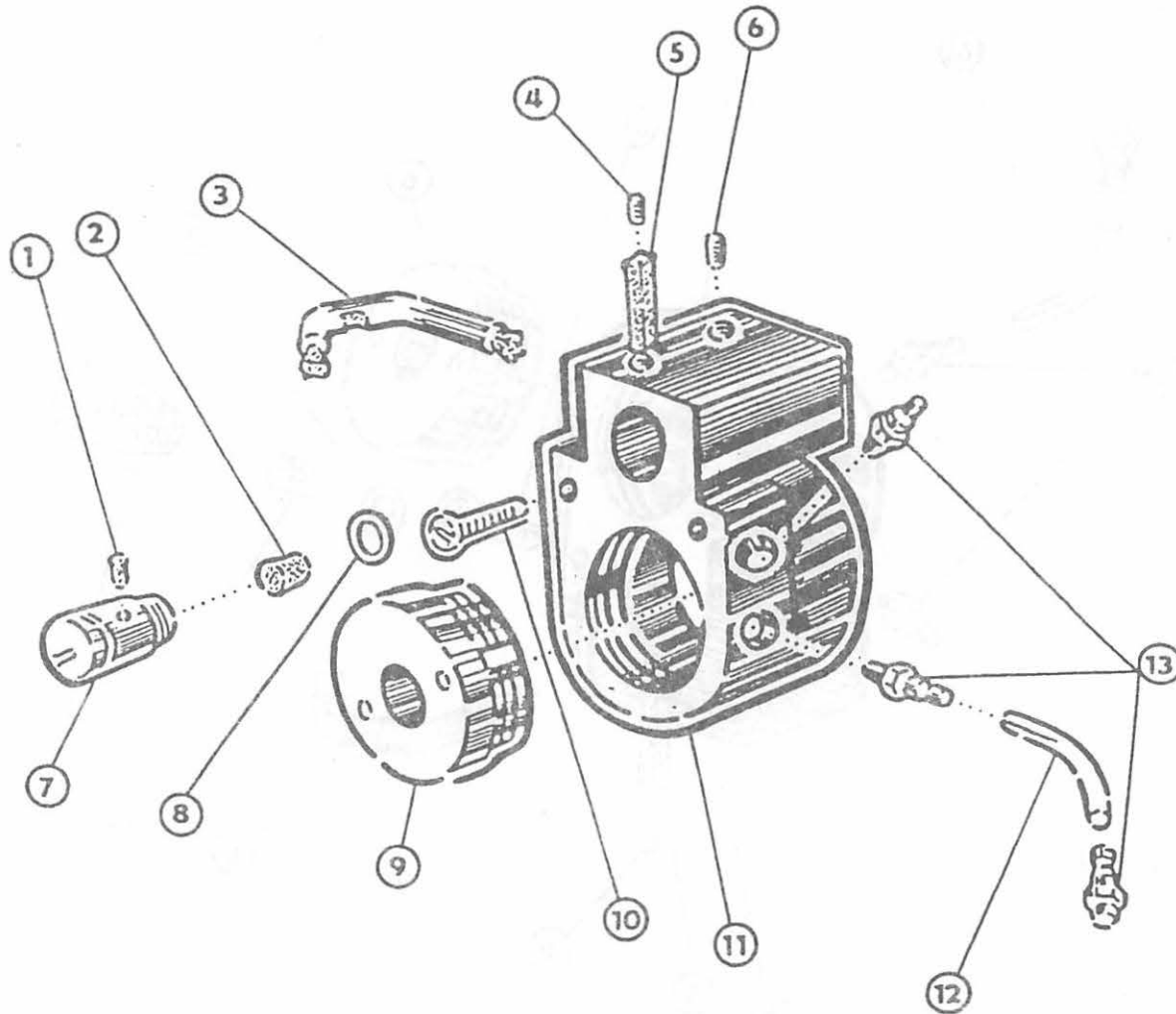

1	522 080	120 269
2	522 980	035 528
3	283 366	002 001
	ø 3,5/ø 4,8 x 100 mm	
4	522 080	424 051
5	522 080	424 060
6	708 420	130 005
	ø 5 x 300 mm	
7	522 080	724 134
8	522 080	120 425
10	283 366	002 001
	ø 3,5/ø 4,8 x 170 mm	

tab. 18

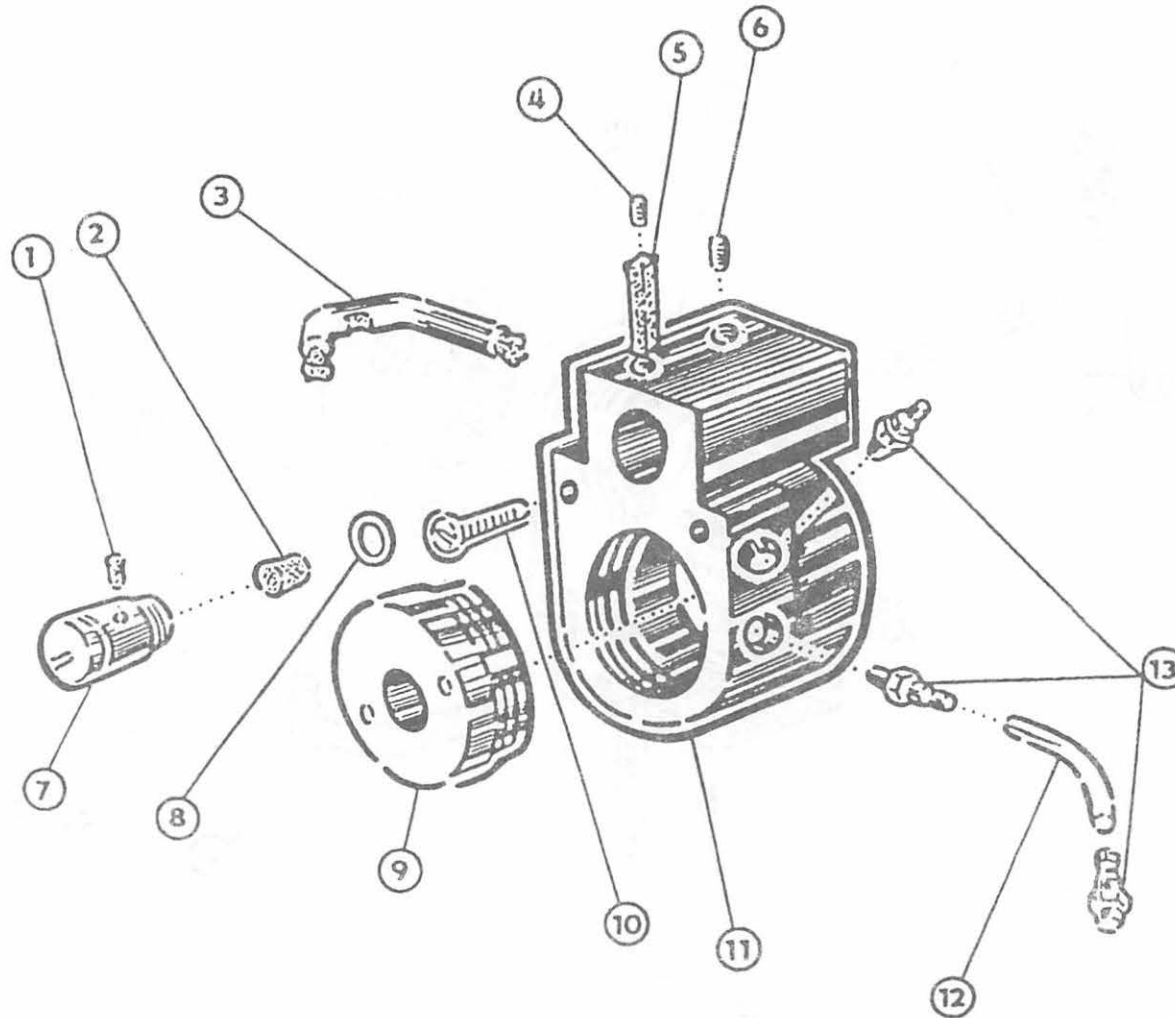

1	522 080	945 170
2	522 080	945 077
3	522 080	035 525
4	522 080	111 252
5	522 080	945 185
6	522 080	111 233
7	522 080	346 053
8	273 111	001 000
9	321 891	001 000
10	522 080	120 269
11	522 080	725 023
12	283 366	002 001
		∅ 3,5/∅ 4,8 x 100 mm
13	522 080	424 051

tab. 19

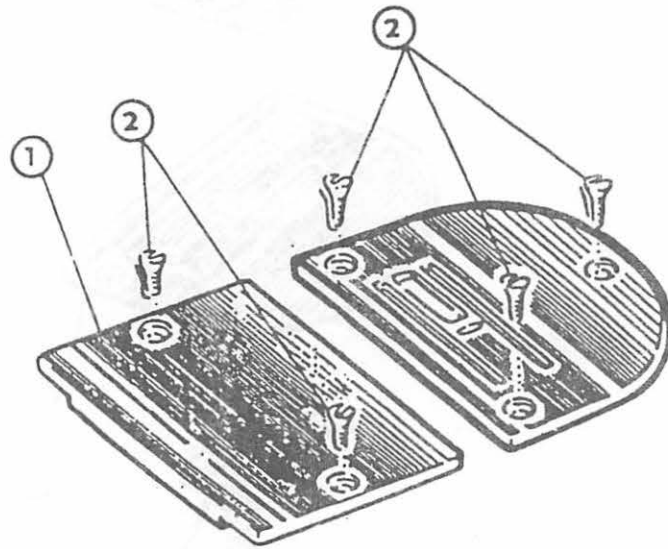

- | | | |
|---|---------|---------|
| 1 | 522 080 | 647 228 |
| 2 | 522 080 | 123 117 |

tab. 20

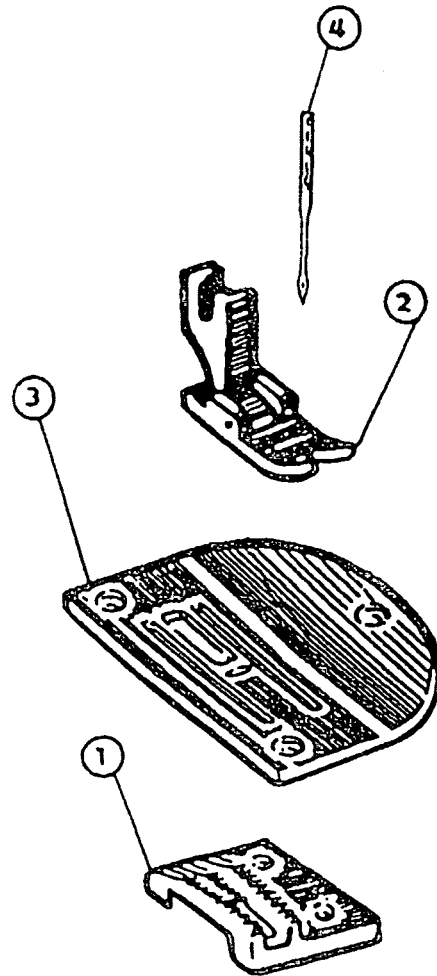

1	522080	651336
2	522980	031602
3	522080	811557
4	134 - 35	No. 120 - 11x

tab. 21

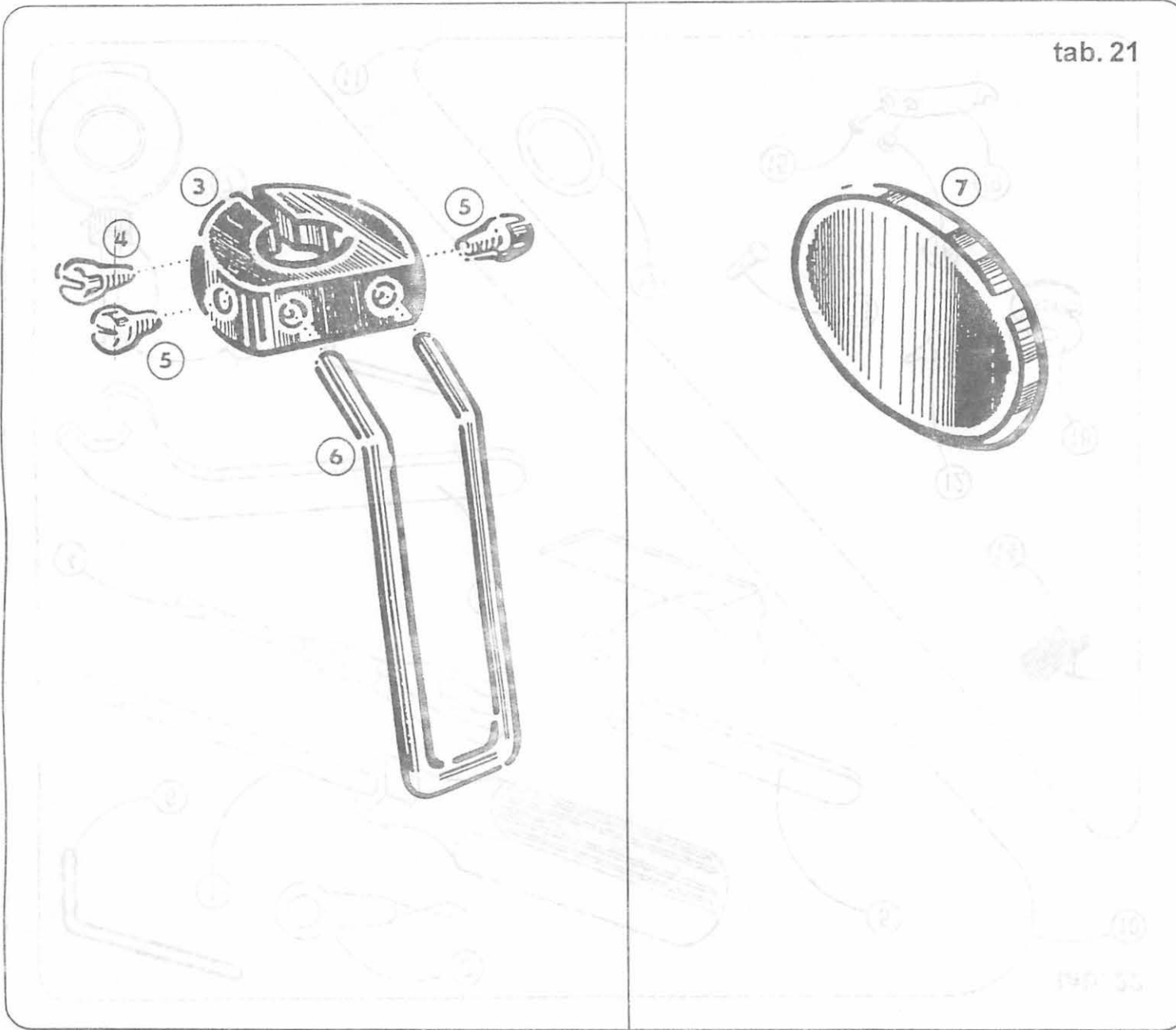

3	522 080	646 136
4	522 080	120 225
5	522 080	120 037
6	522 080	271 441

522 791 995 014

7	522 080	814 355
---	---------	---------

19	522 080	646 136	1
20	522 080	611 091	107
21	522 080	1028 410	107
22	522 080	816 065	107
23	522 080	1075 063	107
24	522 080	1075 063	107
25	522 080	1075 063	107
26	522 080	1075 063	107
27	522 080	1075 063	107
28	522 080	1075 063	107
29	522 080	1075 063	107
30	522 080	1075 063	107
31	522 080	1075 063	107
32	522 080	1075 063	107
33	522 080	1075 063	107
34	522 080	1075 063	107
35	522 080	1075 063	107
36	522 080	1075 063	107
37	522 080	1075 063	107
38	522 080	1075 063	107
39	522 080	1075 063	107
40	522 080	1075 063	107

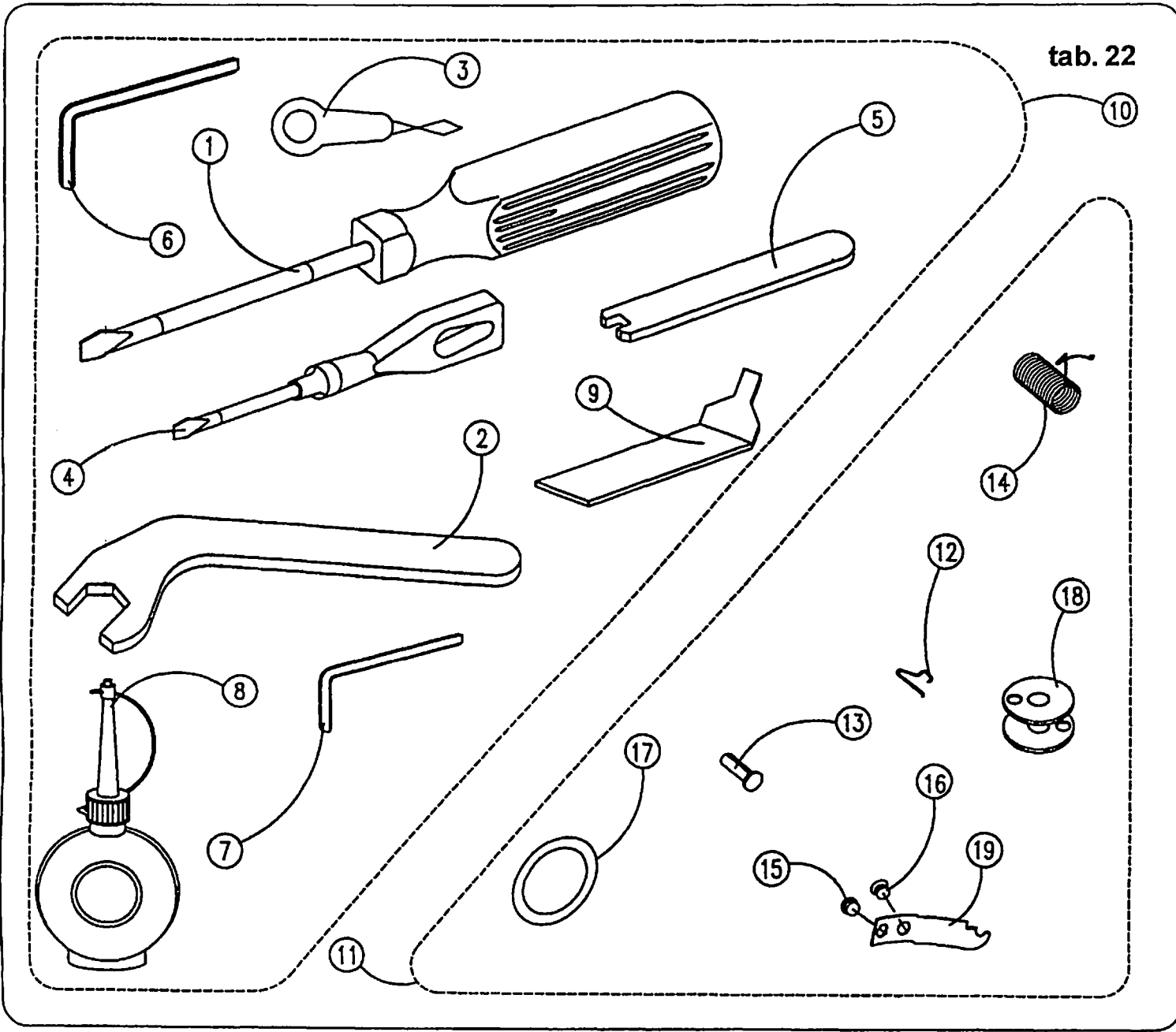

1	413621	731023	
2	522080	818273	
3	548151	001000	
4	413624	310002	
5	522080	813481	
6	413324	000500	
7	413324	000400	
8	562813	002000	
9	522080	829796	
10	522980	09222035	
11	522980	09222935	
12	522080	265037	4 x
13	321861	953200	2 x
14	315231	264294	4 x
15	522080	683063	4 x
16	522080	683053	4 x
17	273111	025410	4 x
18	522080	685051	10 x
19	522080	690029	4 x

tab. 23

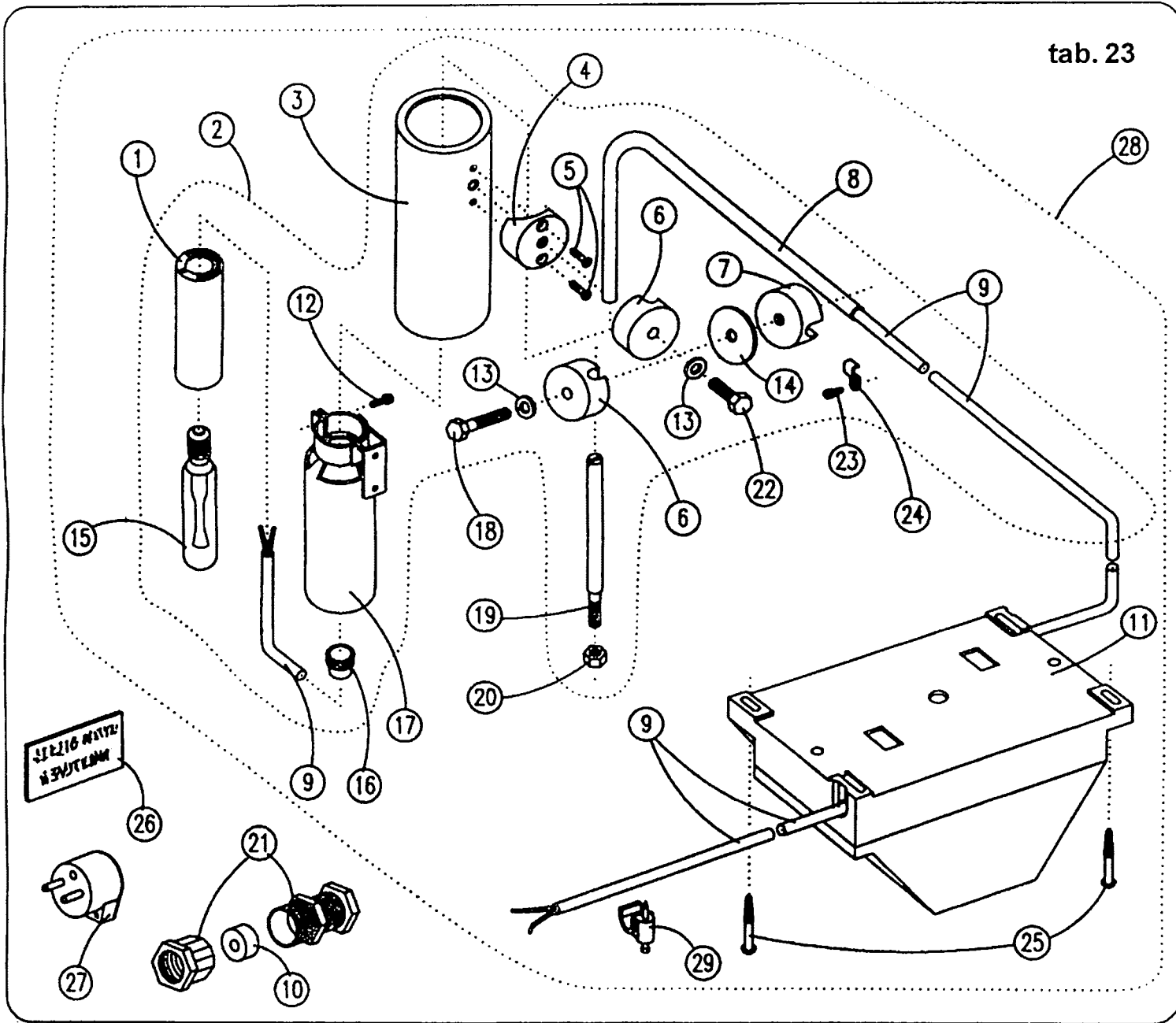

1	345 111	008 000
2	522 980	091 660
3	522 080	831 506
4	522 080	441 501
5	522 080	126 085
6	522 080	441 502
7	522 080	441 570
8	522 080	841 541
9	341 414	028 052
10	345 722	201 000
11	522 980	091 814
12	522 080	120 279
13	522 080	190 347
14	522 080	839 169
15	347 170	002 000
16	321 161	001 000
17	522 980	057 091
18	522 080	141 154
19	522 080	330 088
20	522 080	161 163
21	273 211	006 000
22	522 080	141 265
23	522 080	120 261
24	522 080	824 095
25	522 080	225 018
26	735 413	975 176
27	345 553	620 040
28	522 980	091 816
29	345 711	005 000

8 x

tab. 24

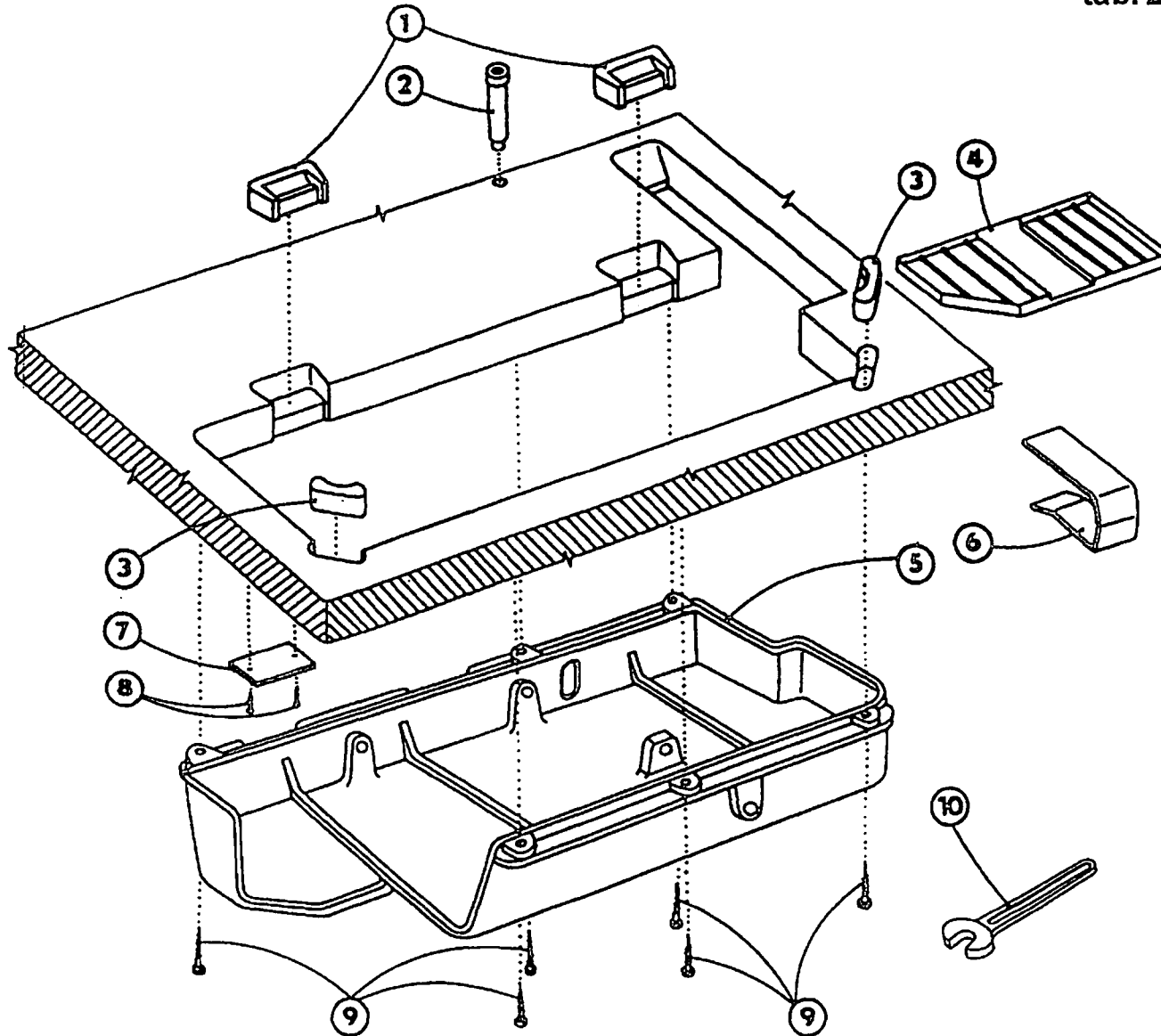

1	273 141	940 127
2	522 980	043 051
3	273 141	940 141
4	321 861	953 251
5	522 080	725 050
6	522 080	826 199
7	522 080	941 091
8	314 140	016 020
9	522 080	225 031
10	413 312	100 130

tab. 25

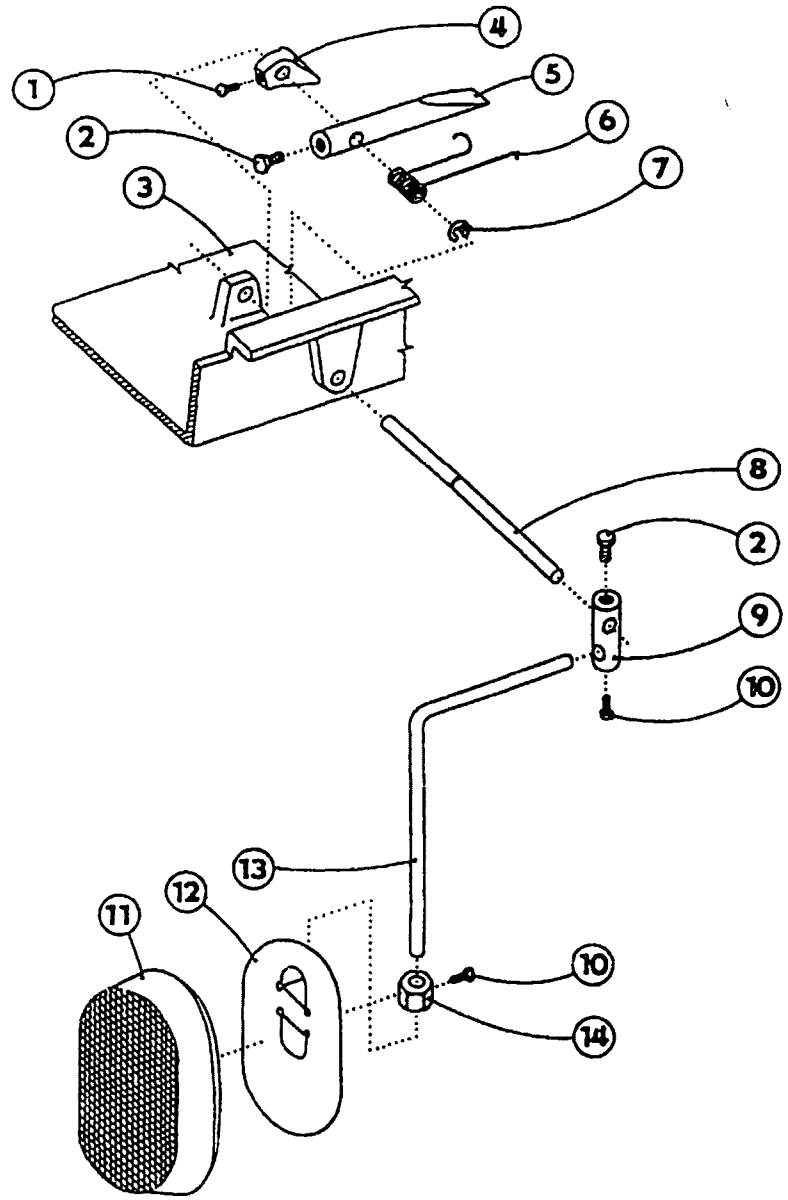

1	522 080	141 141
2	522 080	141 121
3	522 080	725 050
4	522 080	625 022
5	522 080	384 052
6	522 080	264 168
7	311 732	910 070
8	522 080	314 065
9	522 080	318 069
10	522 080	141 112
11	273 412	001 000
12	522 080	827 173
13	522 080	383 022
14	522 080	436 271

tab. 26

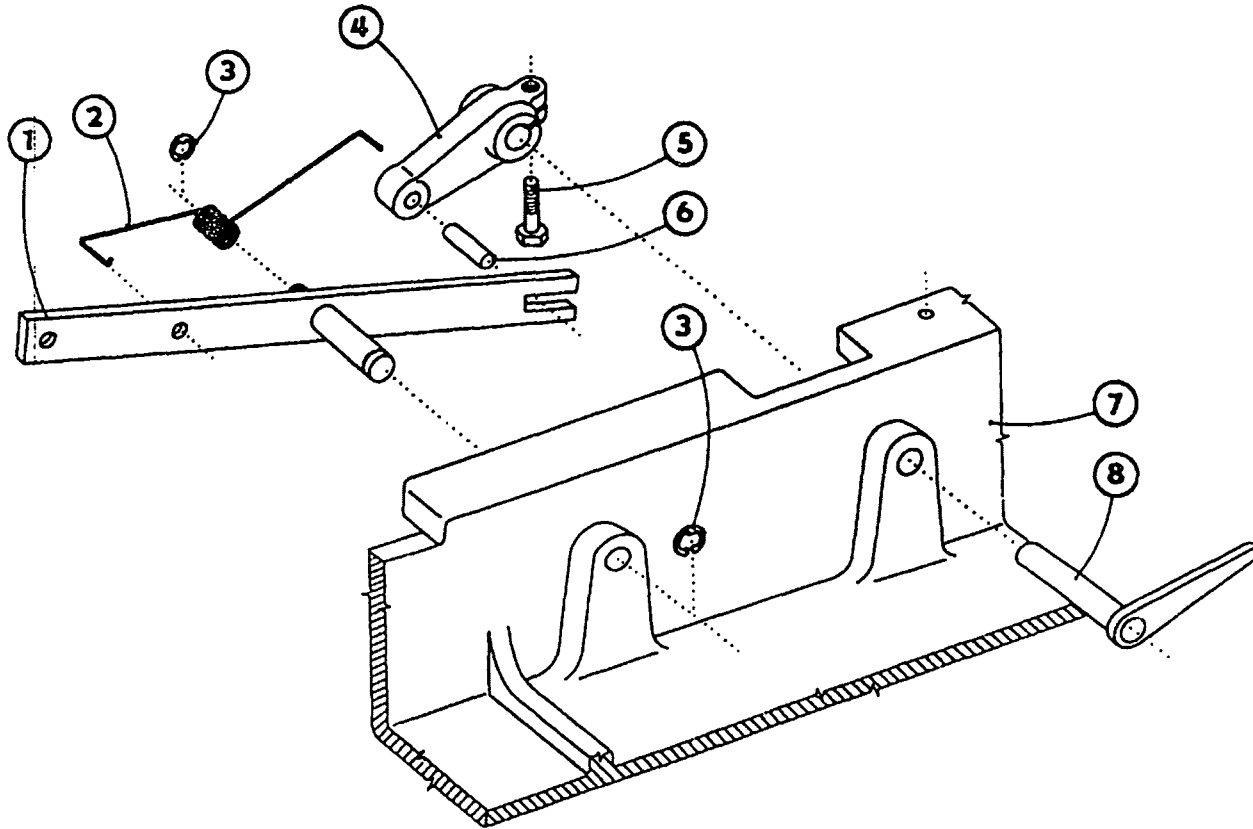

1	522 980	049 109
2	522 080	264 290
3	311 732	910 070
4	522 080	613 480
5	522 080	141 109
6	311 515	006 016
7	522 080	725 050
8	522 980	044 142

tab. 27

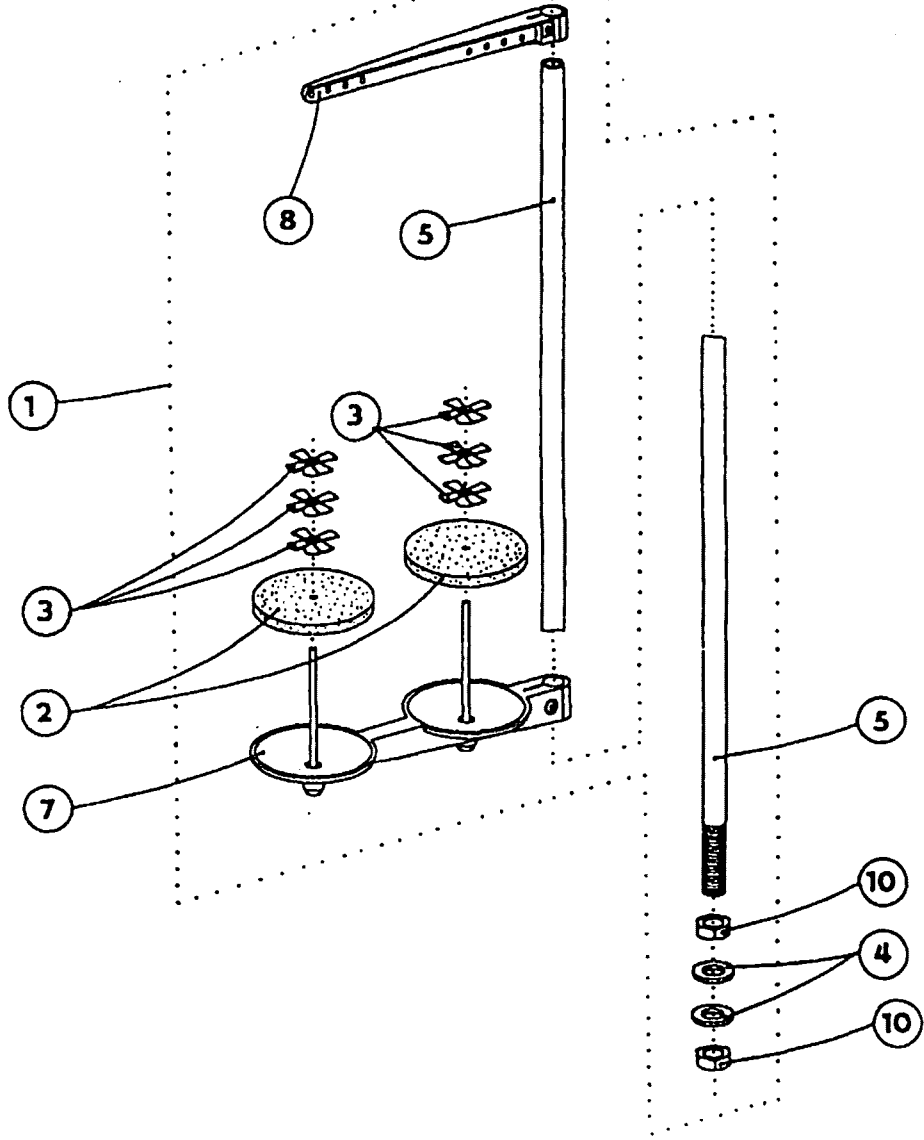

1	522 981	036 163 00	
2	522 077	110 220 80	4 x
3	522 077	110 230 80	12 x
4	522 330	000 177 80	
5	522 791	001 081 80	
7	522 791	001 091 80	2 x
8	522 791	001 096 80	2 x
10	522 995	340 617 80	

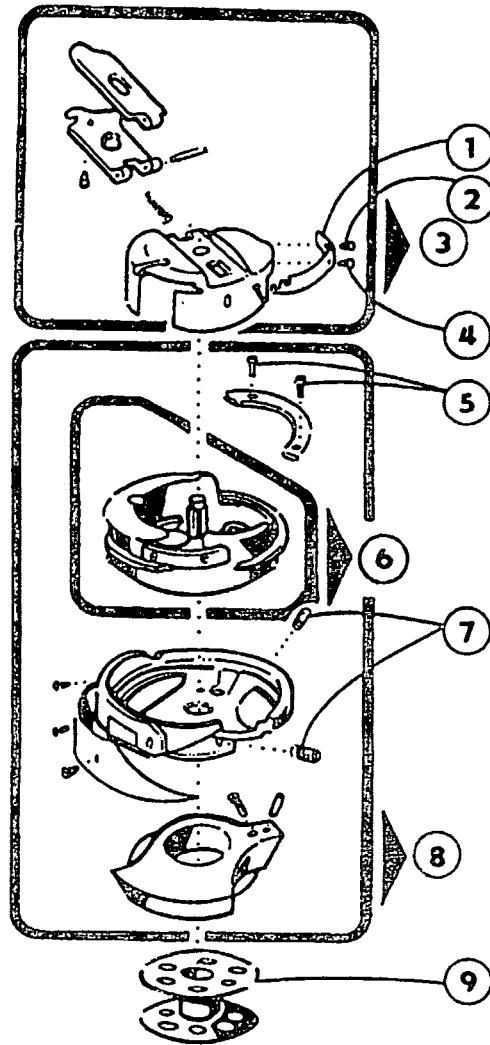
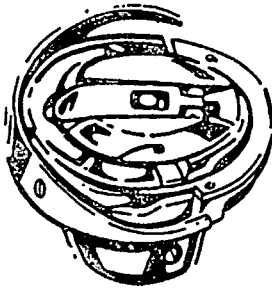

1	522 080	690 029	
2	522 080	683 063	
3	522 980	081 122	
4	522 080	683 053	
5	522 080	683 064	2 x
6	522 980	081 161	
7	522 080	683 067	2 x
8	522 980	081 160	
9	522 080	685 051	

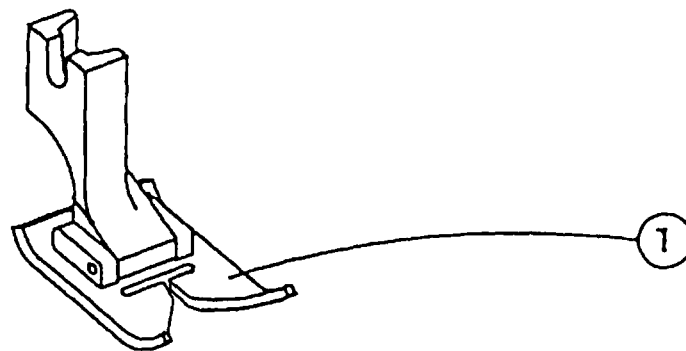

1 522980 031652

SHANGHAI HUIGONG NO.3 SEWING MACHINE FACTORY

ADD: 1418, Yishan Road, Shanghai, China

Zip Code: 201103

Overseas Business: TEL: 86-21-64853303 FAX: 86-21-64854304

E-mail: highlead@online.sh.cn <http://www.highlead.com.cn>

The description covered in this manual is subject to change for improvement of the commodity without notice

2005.1. Printed

From the library of: Superior Sewing Machine & Supply LLC