

Purchasing Dept
Copy

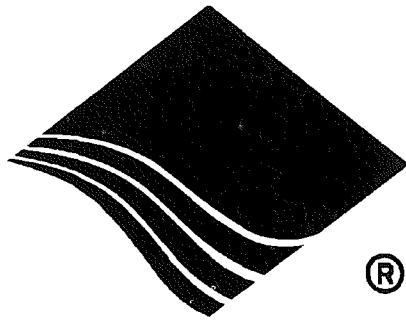

HIGHLEAD

GC24698-2B/-BL/-BR

Super Post Bed Compound Feed Lockstitch Sewing Machine

Instruction Manual
Parts Catalog

SHANGHAI HUIGONG NO.3 SEWING MACHINE FACTORY

From the library of: Superior Sewing Machine & Supply LLC

--- CONTENTS ---

Instruction Manual

▪ Preparation for operation	1
1、 Safety precautions	1
2、 Precautions before starting operation	1
3、 Precautions for operating conditions	1
▪ Cautions on use	1
1、 Lubrication (1)	1
2、 Lubrication (2)	1
3、 Condition of oil lubrication	1
4、 Cautions on operation	2
▪ Operation	2
1、 How to attach needle	2
2、 How to wind the lower thread	2
3、 Selection of Thread	3
4、 How to route the upper thread	3
5、 Adjustment of stitch length and reverse sewing	4
6、 Setting bobbin	4
7、 Threading of bobbin thread	4
8、 Balance of thread tension	4
9、 Lower thread tension	4
10、 Upper thread tension	4
11、 Adjustment of pressure of presser foot	5
12、 Timing between rotating hook motion and needle motion	5
13、 Adjustment of Feed dog height	5
14、 Walking foot and presser foot vertical stroke adjustment	6
15、 Safety clutch device	6
16、 Installation of Belt cover	7
Specifications	7

Parts Catalog

A、 ARM BED AND ITS ACCESSORIES	8
B、 THREAD TENSION REGULATOR MECHANISM	10

C、 ARM SHAFT MECHANISM 13

D、 UPPER SHAFT & PRESSER FOOT MECHANISM 15

E、 TAKE-UP THREAD AND SHAFT MECHANISM 18

F、 STITCH REGULATOR MECHANISM 21

G、 LOWER SHAFT & FEED ROCK SHAFT MECHANISM 23

H、 HOOK SADDLE MECHANISM 26

I、 OIL LUBRICATION MECHANISM 30

J、 ACCESSORIES 33

■ Preparation for operation:

1. Safety precautions:

- 1) When turning the power on, keep your hands and fingers away from the area around/under the needle and the area around the pulley.
- 2) Power must be turned off when the machine is not in use, or when the operator leaves the seat.
- 3) Power must be turned off when tilting the machine head, installing or removing the “V” belt, adjusting the machine, or when replacing.
- 4) Avoid placing fingers, hairs, bars etc. near the pulley, “V” belt, bobbin winder pulley, or motor when the machine is in operation.
- 5) Do not insert fingers into the thread take-up cover, under/around the needle, or pulley when the machine is in operation.
- 6) If a belt cover, finger guard, eye guard are installed, do not operate the machine without these safety devices.

2. Precautions before starting operation:

- 1) Never operate the machine before filling the machine’s oil pan.
- 2) When a new sewing machine is first turned on, verify the rotational direction of the pulley with the power on.
- 3) Verify the voltage and phase (single or three) with those given on the machine nameplate.

3. Precautions for operating conditions:

- 1) Avoid using the machine at abnormally high temperatures (35°C or higher) or low temperatures (5°C or lower) .
- 2) Avoid using the machine in dusty conditions.

■ Cautions on use:

1. Lubrication (1) (Fig.1)

Pour oil up to position “H” of the oil tank.

During operation, check the oil level periodically, and in cases where the oil level is below position “L”, replenish the oil supply up to position “H”.

Use white spindle oil.

2. Lubrication (2) (Fig.2a, Fig.2b)

When a new sewing machine is used for the first time, or sewing machine left out of use for a long time is used again, replenish a suitable amount of oil to the portions indicated by arrow in the fig.

Note: Lubricate the Hook Base everyday.

3. Condition of oil lubrication (Fig.3):

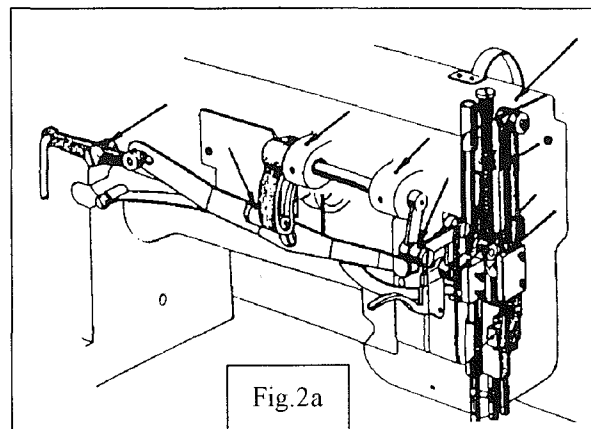
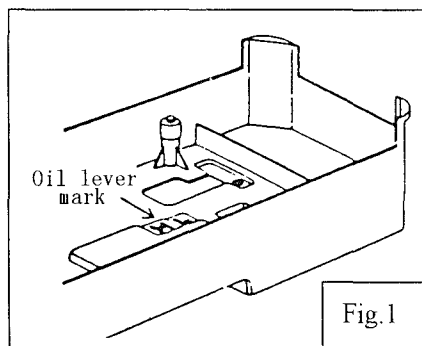

While operating the machine, check the condition of oil lubrication through the oil check window.

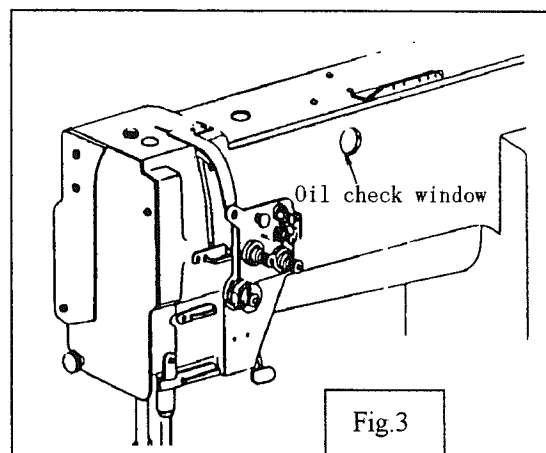
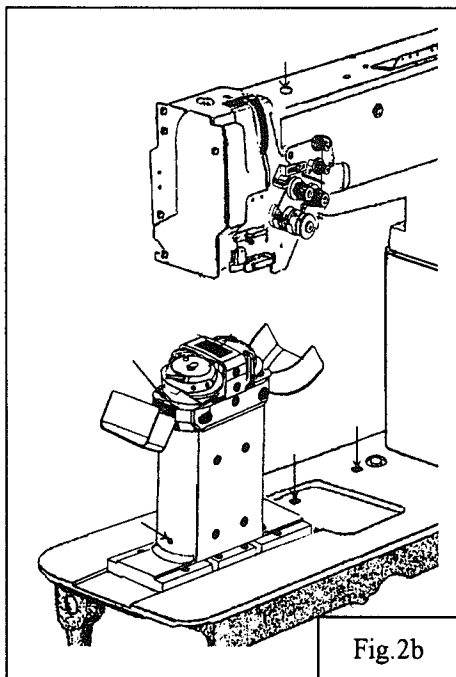

4. Cautions on operation

- 1) When the power is turned on or off, keep foot away from the pedal.
- 2) It should be noted that the brake might not work when the power is interrupted or power failure occurs during sewing machine operation.
- 3) Periodical ly clean the machine.

■ Operation

1. How to attach needle (Fig.4):

Note: Before attach needle, be sure to turn off the power.

- 1) Turn the balance wheel by hand to raise the needle bar to its highest position;
- 2) Loosen the needle clamping screw;
- 3) Hold the needles so that the two needles side with the long grooved (faces each other), and insert it as deeply as it will go into the needle clamping holes(model GC24698-2B);Hold the needle to its side with the long groove side(left),then insert the needle as deeply as it will go into the needle clamping hole(model GC24698-BL/BR).
- 4) Tighten the needle clamping screw.

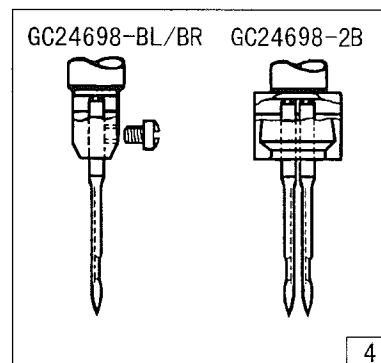

2. How to wind the lower thread (Fig.5):

Strength of winding: Particularly in the case of nylon or polyester thread, wind the bobbin loosely.

Uneven winding: If the bobbin is wound unevenly, slide the thread guide toward the less wound portion of bobbin.

Winding amount: When the bobbin is wound excessively, loosen the adjusting screw. When the bobbin is wound

insufficiently, tighten the adjusting screw.

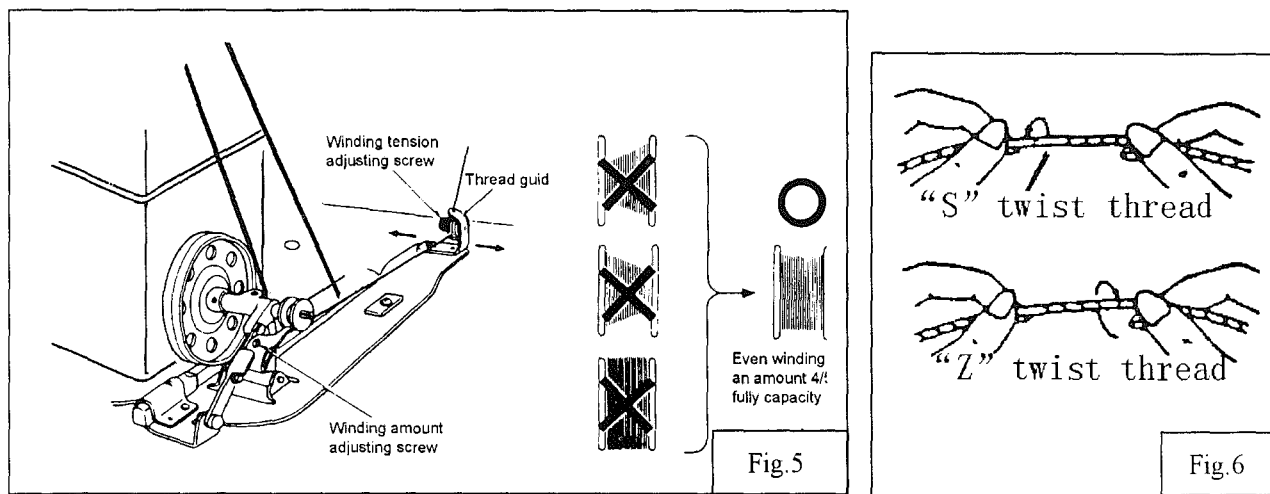

3. Selection of Thread (Fig.6) :

It is recommended to use "S" twist thread in the left needle (Viewed from front), and "Z" twist thread in the right needle.

When discriminate use of needle thread is impossible, use "Z" twist thread in the needle. For bobbin thread, "S" twist thread as well as "Z" twist thread can be used.

4. How to route the upper thread (Fig.7, Fig.8):

1) Pass each upper thread through thread guide A

Note: when thin slippery thread (polyester thread for example) is used pass the thread through thread guide B as show in Fig.7

2) With the take-up lever located at the upper most position, pass each thread in the order in Fig.8.

Note: Pressing the upper thread loosening button, the upper thread can be pulled out easily.

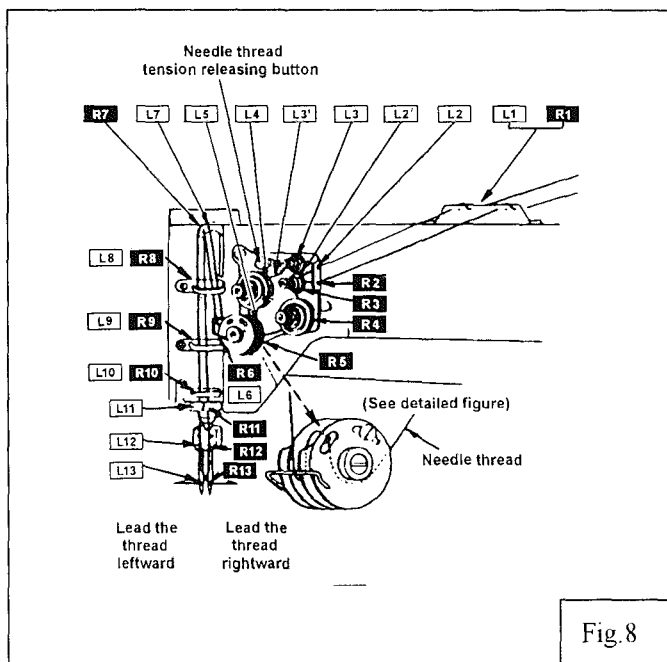
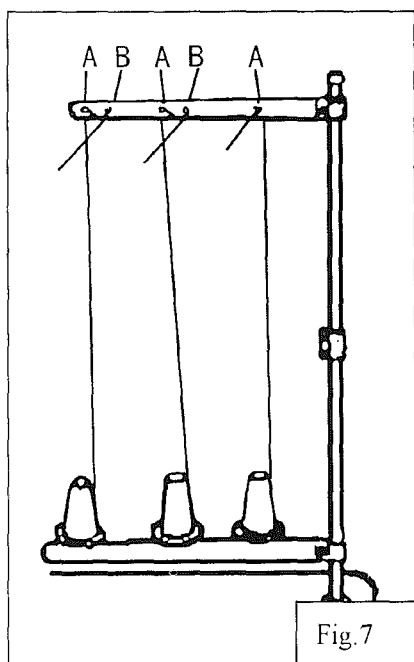

5. Adjustment of stitch length and reverse sewing (Fig.9):

- 1) Rotate the stitch length adjusting dial to change the stitch length
- 2) Pressing the stitch length adjusting lever for reverse stitching.

6. Setting bobbin (Fig.10):

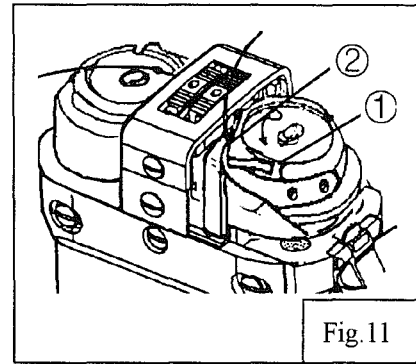
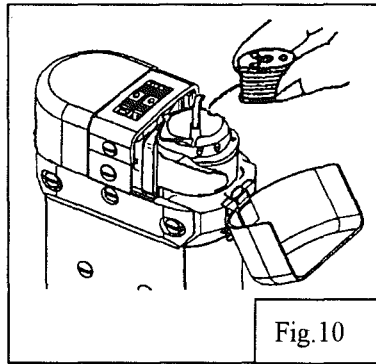
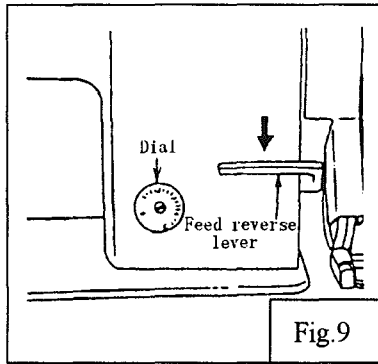

- 1) Pulling out 5cm thread tail from the bobbin;
- 2) Hold the bobbin so that the bobbin thread is would in tight direction and put it into the hook.

7. Threading of bobbin thread (Fig.11, Fig.12):

1) Flap down the latch lever, from the slit 1 of the hook, pass the thread through underneath of the hook body 2, pull the thread outside (Fig.11);

2) While holding the needle thread by left hand, rotate the hand wheel one turn by right hand. By pulling up the needle thread, the bobbin thread will be lifted. Close the slide plate (Fig.12)

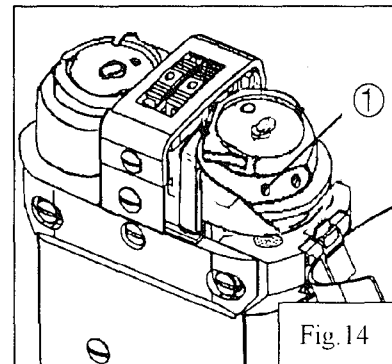
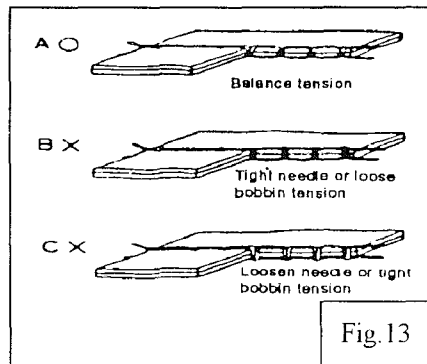
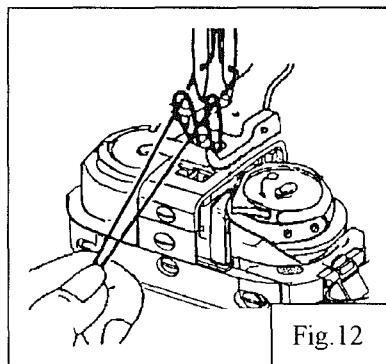

8. Balance of thread tension (Fig.13):

9. Lower thread tension (Fig.14):

There is virtually no need to adjust the lower thread tension, except for special kind of the fabrics or thread, when slight adjustment will be necessary.

Turning the screw 1 clockwise will increase the tension of lower thread, otherwise, the tension of lower thread will decrease. (Fig.14).

10. Upper thread tension (Fig.15):

1) The upper thread can be adjusted based on the lower thread tension.

2) Adjustment can be done by rotating the thread tension nut.

11. Adjustment of pressure of presser foot

(Fig.16):

1) Pressure should be adjusted according to the material to be sewn.

2) Turning the pressure adjusting screw to adjust the pressure of presser foot

12. Timing between rotating hook motion and needle motion (Fig.17):

1) Set stitch length to "6";

2) When needle is lifted 2.4mm from the lower dead point, the following position relationship should be maintained:

- The upper edge of needle eye should be 2.3mm below the hook point
- The hook point should be located at the center of needle axis.
- Gap between the hook point and the side face of needle should be 0.05 mm

13. Adjustment of Feed dog height (Fig.18):

Height of feed dog should be adjusted for individual fabrics with the following cautions:

1) Fabric will be damaged if the feed dog extends too high or pressure of presser foot is too large

2) Even stitch length cannot be assured if the feed dog is too low or pressure of presser foot is too small

3) Feed dog height should be measured at the point where the needle is at the top position.

For light fabric: Approx 0.8mm

For usual fabric: Approx 1.0mm

For heavy fabric: Approx 1.2mm

Adjustment procedure:

1) Lay down the machine bed toward the other side;

2) Turn the balance wheel by hand stop when the feed dog is raised to its highest position from the surface of needle plate;

3) Loosen the Screw and adjust the height of the feed dog;

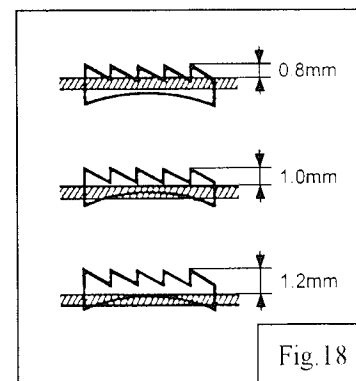
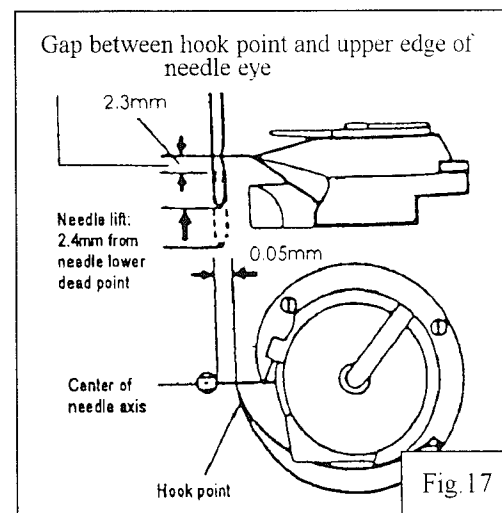
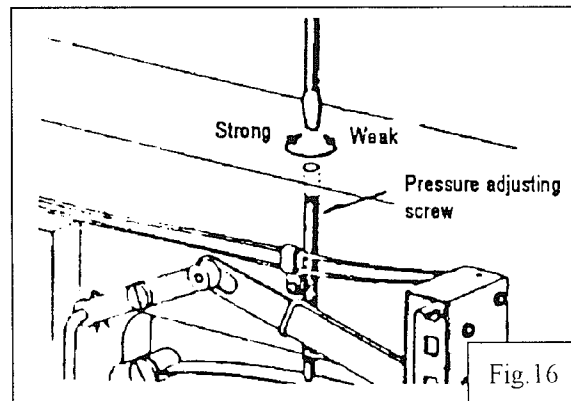
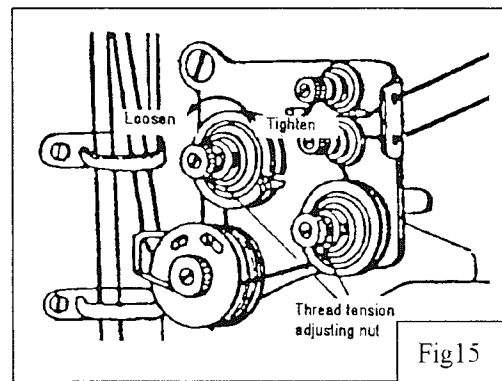

4) After adjusted, tighten the screw.

The feed dog height is factory-adjusted to 1.2mm

14. Walking foot and presser foot vertical stroke adjustment (Fig.19):

When fabric with large elasticity is sewn, or when thickness of fabric changes, the vertical stroke (movable range) of the presser feet should be adjusted as follows:

- 1) Loosen the special bolt;
- 2) The vertical strokes of presser feet become maximum when the crank rod is moved downward and set;
- 3) The vertical strokes of presser feet become minimum when the crank rod is moved upward and set;
- 4) After the adjustment, tighten the special nut.

The vertical strokes of presser feet can be adjusted within a range from 2mm to 6mm.

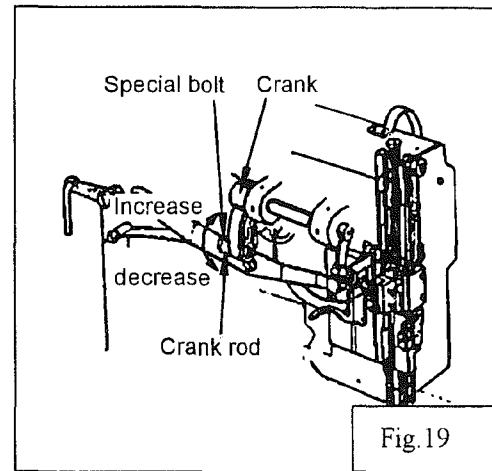

15. Safety clutch device (Fig.20, Fig.21)

Safety clutch device is installed to prevent the hook and cog belt from damage in case the thread is caught into the hook when the machine is loaded abnormally operation.

1) Function of safety clutch:

- A. When the safety clutch acts, the cog belt pulley will be unloaded. Then the rotation of hook shaft will stop. The arm shaft only will rotate. Stop the operation of machine.
- B. Clean the thread thoroughly which is caught into the hook.
- C. Turn the cog belt hub by hand, and check whether the hook shaft rotates lightly and properly, place the clutch device as follows.

2) How to set the safety clutch (Fig.20)

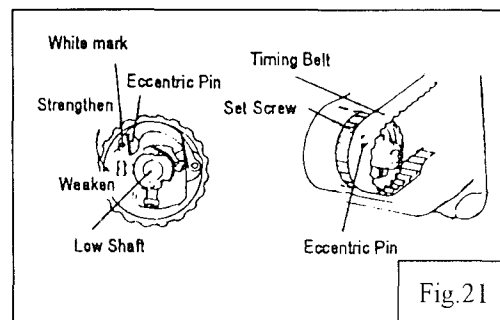
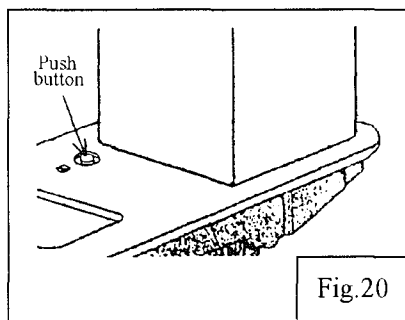

- A. While pressing down the push button on the opposite side of bed by left hand, turn the balance wheel slowly by right hand away from you;
- B. The balance wheel will stop by the gear plate, but turn the balance wheel more firmly;
- C. Release the push button, the safety clutch device is set.

3) Force applied to the safety clutch (Fig.21)

- A. The force applied to the safety clutch is the smallest when the mark of eccentric pin faces the center of the lower shaft. The force proportionally increases as the mark faces the outside;
- B. To adjust the force slide the timing belt, loosen the set screw, and turn the eccentric pin;
- C. After the adjustment, tighten the set screw.

16. Installation of Belt cover:

- 1) Fixed 1 to the arm with screws
- 2) Fixed 3 to 1 with screws
- 3) Fixed 4 to 3 and arm with screws

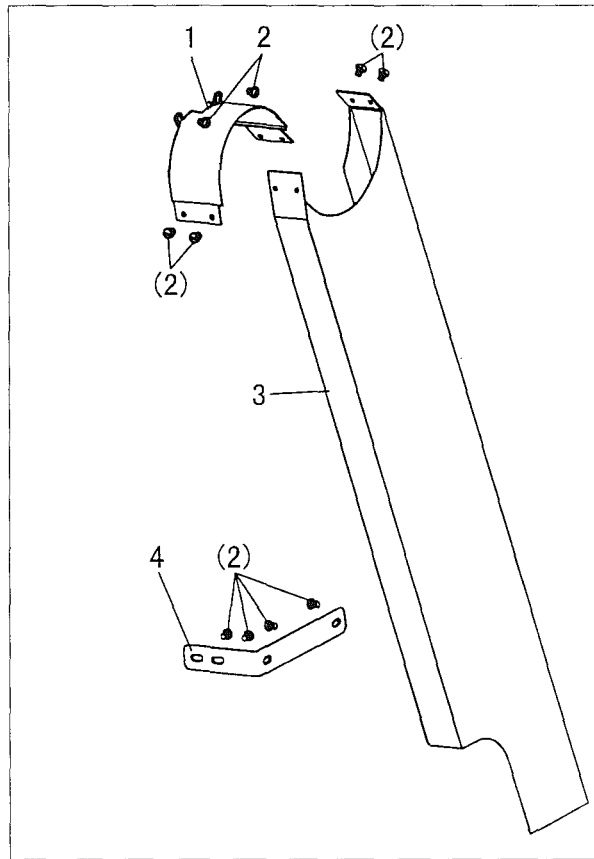

Specifications:

Spec		Model	GC24698-2B	GC24698-BL/BR
Material weight		Medium Heavy material		
Max. sewing speed		2000rpm		
Stitch length		0-7mm		
Needle bar stroke		36mm		
Presser foot stroke	By hand	8mm		
	By knee	16mm		
Alternating movement		2-6mm		
Stitch-length adjusting		Dial type		
Alternating movement		Automatic		
Needle		DP×17 (22#--24#)		
Motor		Clutch motor 370W		
Needle gauge		7.94mm 9.52mm		

A. ARM BED AND ITS ACCESSORIES

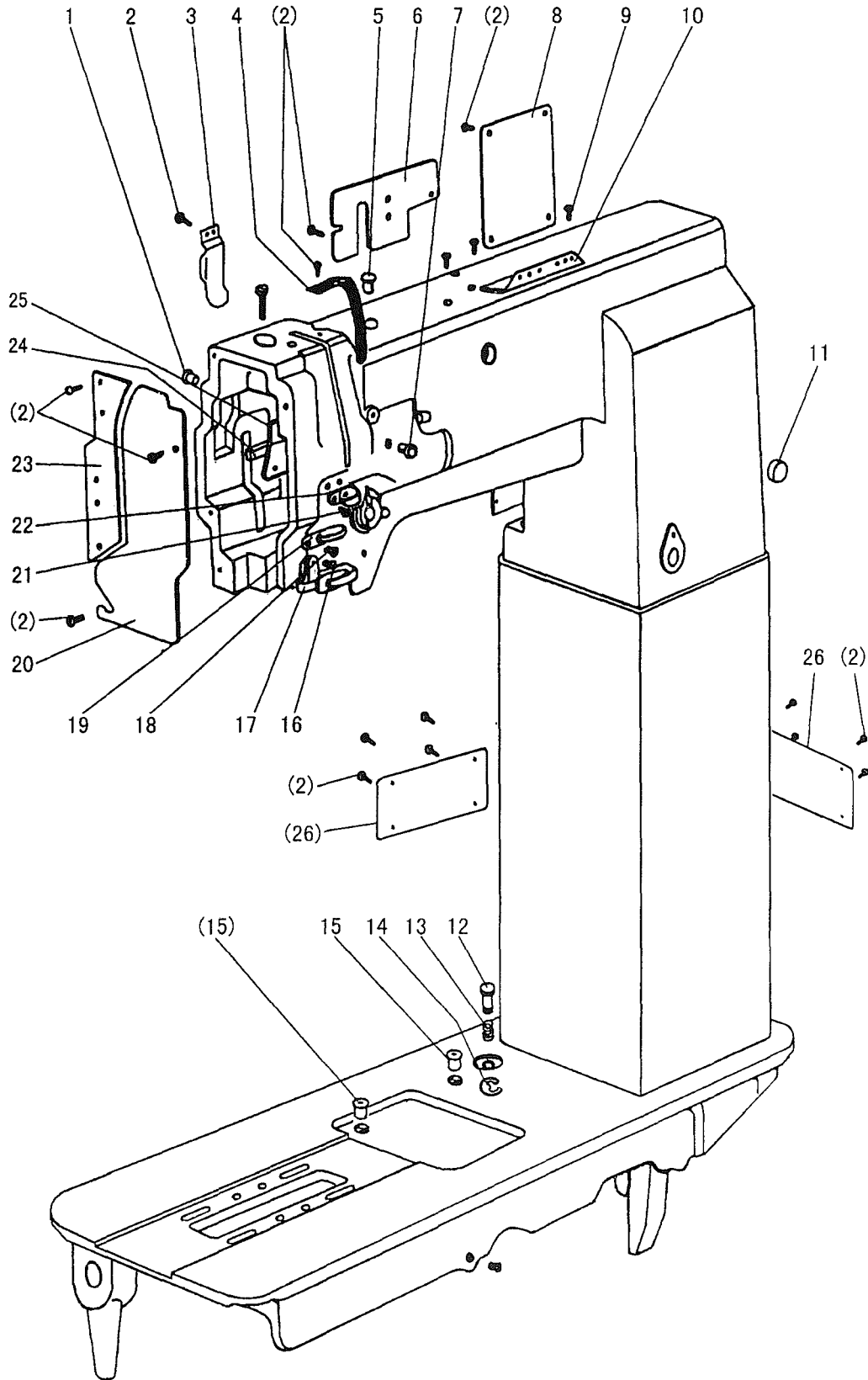

A.ARM BED AND ITS ACCESSORIES

Fig. No.	Part No.	Description	GC24698-2B	GC24698-BL	GC24698-BR	Remarks
A01	HA300B2090	Rubber plug	2	2	2	
A02	HA300B2170	Screw	42	42	42	11/64 (40) ×9
A03	H4716B8001	Oil guide plate	1	1	1	
A04	H4717B8001	Thread take-up cover	1	1	1	
A05	H4715B8001	Rubber plug	1	1	1	
A06	H4718B8001	Arm side cover (left)	1	1	1	
A07	H2000B2010	Rubber plug	1	1	1	
A08	H4719B8001	Arm side cover (right)	1	1	1	
A09	HA700B2060	Screw	2	2	2	11/64 (40) ×8
A10	H2400B2100	Thread guide	1	1	1	
A11	HA307B0673	Rubber plug	1	1	1	
A12	H4715H8001	Push button	1	1	1	
A13	H4714H8001	Spring	1	1	1	
A14	H007013050	E-type ring	1	1	1	
A15	H2000M0090	Cap	2	2	2	
A16	H3200B2100	Screw	1	1	1	9/64 (40) ×6.5
A17	H3212B0066	Thread guide	1	1	1	
A18	H3000D2160	Screw	1	1	1	9/64 (40) ×4.5
A19	H4727B8001	Face plate	1	1	1	
A20	H4726B8001	Thread guide	1	1	1	
A21	H2400B2080	Screw	2	2	2	3/16 (28) ×12.1
A22	H2400B2070	Thread guide	1	1	1	
A23	H4730B8001	Guide mounting plate	1	1	1	
A24	H2400B2060	Spacer	1	1	1	
A25	H3200B2060	Oil guide plate	1	1	1	
A26	H7117B8001	Arm side cover	2	2	2	

B. THREAD TENSION REGULATOR MECHANISM

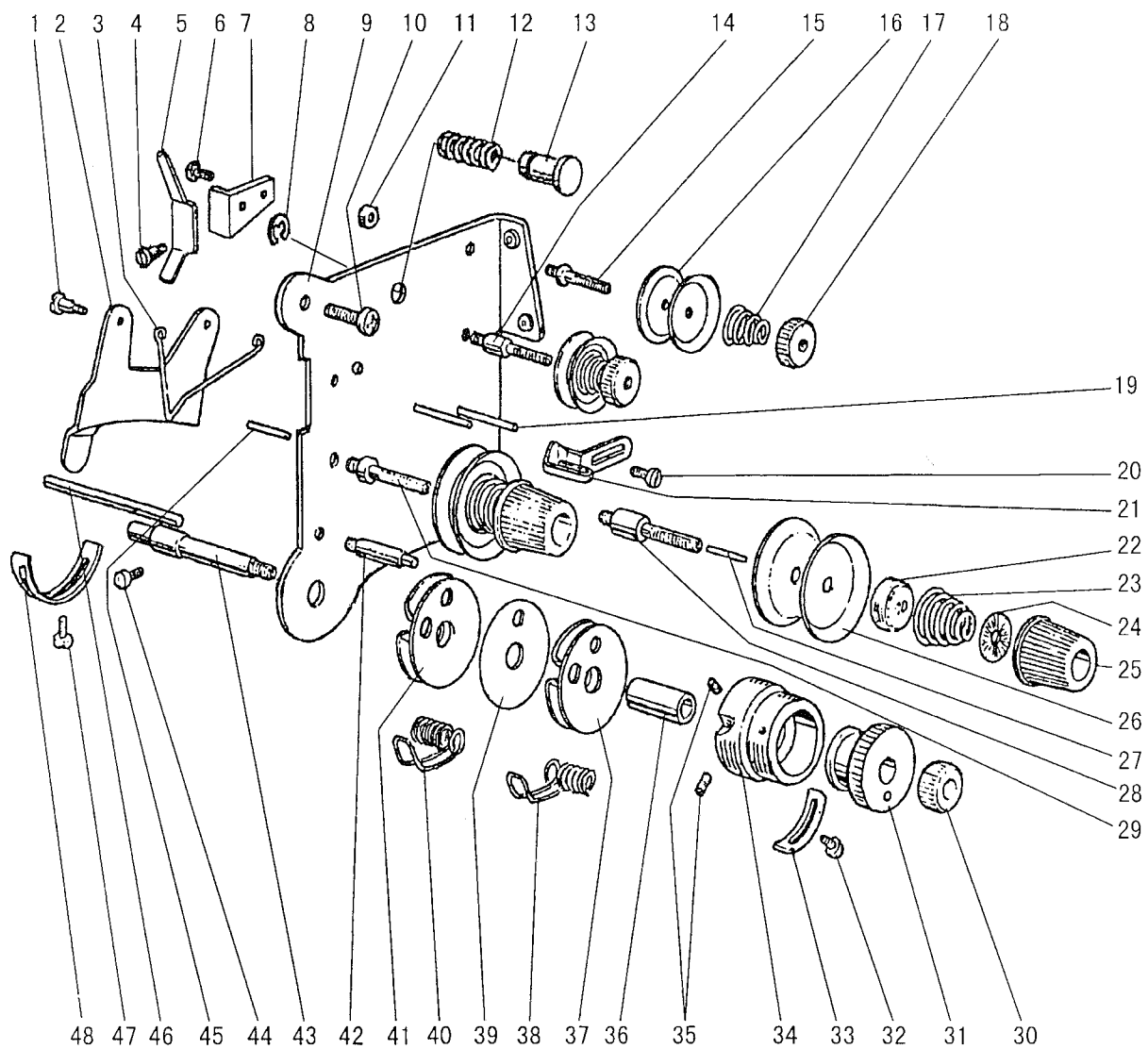

B.THREAD TENSION REGULATOR MECHANISM

Fig. No.	Part No.	Description	GC24698-2B	GC24698-BL	GC24698-BR	Remarks
B01	H2504C6510	Screw	2	2	2	9/64 (40) ×3
B02	H3221B3142	Tension releasing plate	1	1	1	
B03	H3221B6812	Tension releasing spring	1	1	1	
B04	H4705C8001	Screw	1	1	1	
B05	H4706C8001	Lever	1	1	1	
B06	HA7311C306	Screw	1	1	1	9/64 (40) ×7
B07	H4707C8001	Mounting plate	1	1	1	
B08	H007013050	E-type ring	1	1	1	
B09	H3221B6820	Mounting plate	1	1	1	
B10	HA300C2030	Screw	2	2	2	11/64 (40) ×8
B11	H3221B6810	Nut	2	2	2	
B12	H4708C8001	Spring	1	1	1	
B13	H4709C8001	Push button	1	1	1	
B14	H3221B0685	Thread tension stud	1			11/64 (40) ×14
B15	H3221B0683	Thread tension stud	1	1	1	11/64 (40) ×14
B16	HA112B0693	Thread tension disc	4	2	2	
B17	H3221B0684	Spring		1	1	
B17	H3300B2040	Spring	2			
B18	HA710B0671	Thumb nut	2	1	1	
B19	H3221B0682	Pin	3	2	2	
B20	HA106B0676	Screw	1	1	1	9/64 (40) ×6
B21	H3306B0661	Thread guide	1	1	1	
B22	HA310B0702	Tension releasing disc	2	1	1	
B23	H4710C8001	Spring	2	1	1	
B24	HA115B7010	Thumb nut revolution stopper	2	1	1	
B25	HA310B0701	Thumb nut	2	1	1	
B26	HA310B0705	Thread tension disc	4	2	2	
B27	H3221B6816	Pin	1			
B28	H3221B0689	Thread tension stud	1			1/4 (40) ×23
B29	H3221B0686	Thread tension stud	1	1	1	1/4 (40) ×23
B30	H32481B721	Thumb nut	1	1	1	
B31	H32481B621	Take-up spring guide	1			
B32	H32481BC21	Screw	1			9/64 (40) ×6
B33	H32481BB21	Stopper	1			
B34	H32481B921	Thread tension post	1			
B35	H32481B521	Screw	2			1/8 (44) ×3.9
B36	H32481B821	Bushing	1			
B37	H32481BF21	Plate complete	1			
B38	H4712C8001	Thread take-up spring	1			
B39	H32481BE21	Plate complete	1			
B40	H4713C8001	Thread take-up spring	1	1	1	
B41	H32481BD21	Plate complete	1	1	1	
B42	H32481B421	Thread tension stud	1			9/64 (40) ×2.9

B.THREAD TENSION REGULATOR MECHANISM

Fig. No.	Part No.	Description	GC24698-2B	GC24698-BL	GC24698-BR	Remarks
B42	H4804C8001	Thread tension stud		1	1	9/64 (40) ×2.9
B43	H32481B121	Thread tension stud	1			1/4 (40) ×38.5
B43	H4805C8001	Thread tension stud		1	1	1/4 (40) ×14.5
B44	H3230K0751	Screw	1	1	1	11/64 (40) ×10
B45	H3221B6817	Pin	1	1	1	
B46	H4769E8001	Pin	1	1	1	
B47	H3200B2100	Screw	1	1	1	9/64 (40) ×6.5
B48	H3221B6819	Stopper	1	1	1	

C. ARM SHAFT MECHANISM

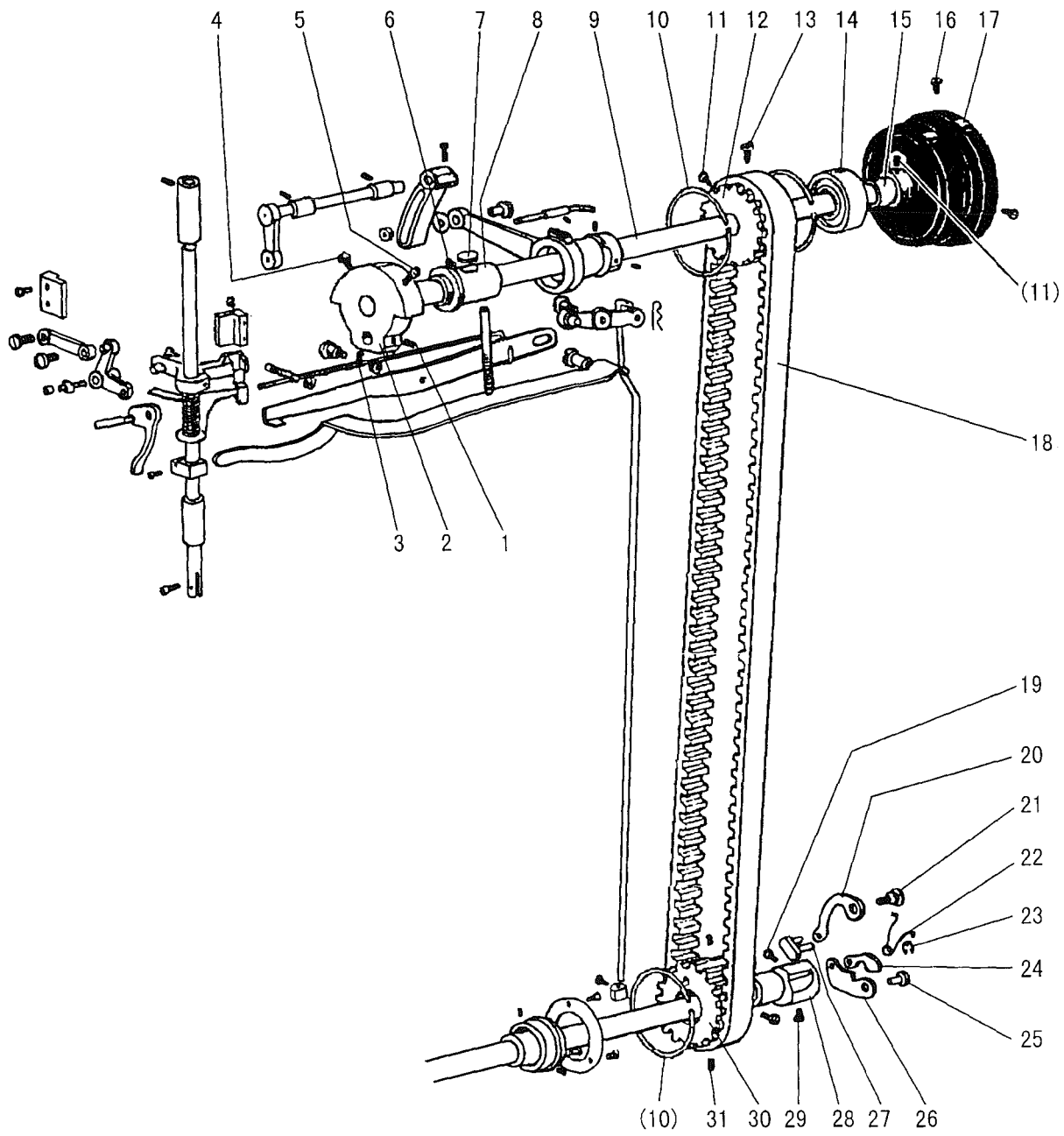

C.ARM SHAFT MECHANISM

Fig. No.	Part No.	Description	GC24698-2B	GC24698-BL	GC24698-BR	Remarks
C01	HA307C0662	Set screw	1	1	1	1/4 (40) ×6
C02	H4706D8001	Crank	1	1	1	
C03	HA105D0662	Set screw	1	1	1	1/4 (40) ×4
C04	HA100C2060	Screw	1	1	1	9/32 (28) ×13
C05	HA100C2070	Screw	1	1	1	9/32 (28) ×14
C06	H4708D8001	Set screw	1	1	1	1/4(24)×13
C07	H32111B104	Felt	1	1	1	
C08	H32111B204	Arm shaft bushing (left)	1	1	1	
C09	H4709D8001	Arm shaft	1	1	1	
C10	H3205C0661	Spring flange	3	3	3	
C11	HA113F0684	Screw	1	1	1	15/64 (28) ×8.5
C12	H3205C1021	Pulley	1	1	1	
C13	HA100F2130	Screw	1	1	1	15/64 (28) ×14.5
C14	H3205J0662	Bearing	1	1	1	
C15	H3205J0661	Collar	1	1	1	
C16	HA110D0672	Screw	2	2	2	15/64 (28) ×12
C17	H4100C2040	Pulley	1	1	1	
C18	H7104D8001	Cog belt	1	1	1	
C19	HA104F0654	Screw	1	1	1	15/64 (28) ×10
C20	H4713D8001	Link	1	1	1	
C21	H4714D8001	Pin	1	1	1	
C22	H4716D8001	Spring	1	1	1	
C23	H007013025	E-type ring	1	1	1	
C24	H4717D8001	Link	1	1	1	
C25	H4718D8001	Pin	1	1	1	
C26	H4719D8001	Link	1	1	1	
C27	H4715D8001	Pin	1	1	1	
C28	H4720D8001	Bushing	1	1	1	
C29	H4721D8001	Screw	1	1	1	15/64(28)×10.5
C30	H4722D8001	Pulley	1	1	1	
C31	H4723D8001	Screw	2	2	2	15/64(28)×4.5

D. UPPER SHAFT & PRESSER FOOT MECHANISM

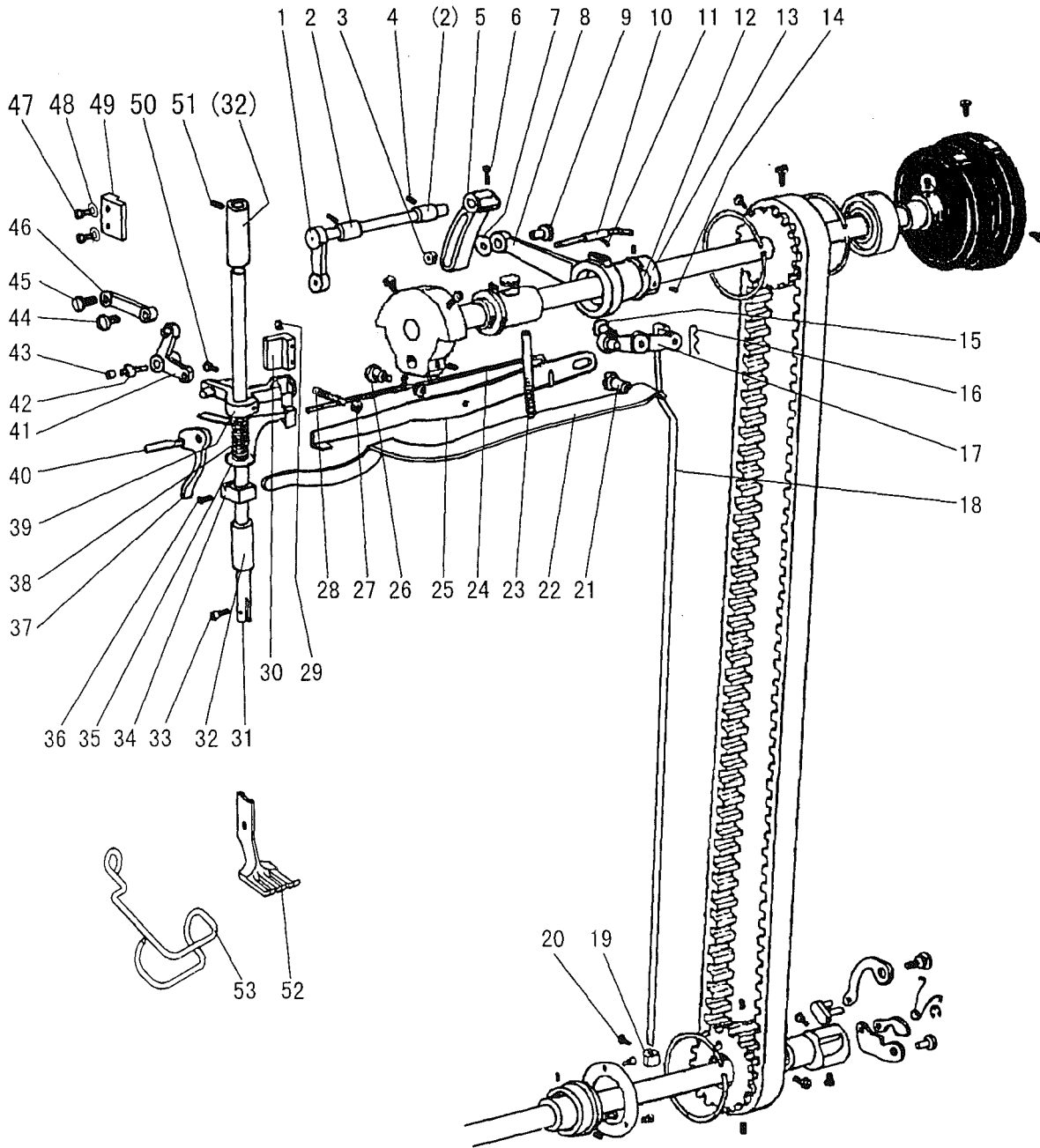

D.UPPER SHAFT & PRESSER FOOT MECHANISM

Fig. No.	Part No.	Description	GC24698-2B	GC24698-BL	GC24698-BR	Remarks
D01	H4705E8001	Feed lifting rock shaft	1	1	1	
D02	H4707E8001	Bushing	2	2	2	
D03	H003055060	Nut	1	1	1	
D04	H4706E8001	Set screw	2	2	2	1/4 (24)×7
D05	H4709E8001	Crank	1	1	1	
D06	H3115F0671	Screw	1	1	1	1/4 (28) ×16
D07	H2013J0065	Washer	1	1	1	
D08	H2014J0066	Connecting rod	1	1	1	
D09	H2000J2100	Screw	1	1	1	
D10	H4713E8001	Oil wick	1	1	1	
D11	H20111C106	Holder	1	1	1	
D12	H007009250	C-type ring	1	1	1	
D13	H4714E8001	Eccentric	1	1	1	
D14	HA307C0662	Screw	2	2	2	1/4 (40) ×6
D15	H4732E8001	Screw	1	1	1	1/4 (24) ×14
D16	H4739E8001	Snap pin	1	1	1	
D17	H4734E7101	Knee lifter lifting lever	1	1	1	
D18	H7104E8001	Operation rod	1	1	1	
D19	H4741E8001	Collar	1	1	1	
D20	H4742E8001	Screw	1	1	1	11/64 (40) ×5.5
D21	H3100G2170	Screw	1	1	1	1/4 (24) ×17
D22	H4730E8001	Lever spring	1	1	1	
D23	H4729E8001	Screw	1	1	1	15/64 (28) ×79
D24	H4727E8001	Twist spring	1	1	1	
D25	H4728E8001	Knee lifting lever	1	1	1	
D26	H3100G2130	Screw	1	1	1	1/4 (24) ×7
D27	H4726E8001	Nut	1	1	1	
D28	H4725E8001	Screw	1	1	1	1/4 (24) ×19
D29	HA111G0683	Screw	2	2	2	11/64(40)×12
D30	H4723E8001	Guide	1	1	1	
D31	H4754E8001	Presser bar	1	1	1	
D32	H4744E8001	Bushing	1	1	1	
D33	H3200E2020	Screw	1	1	1	1/8(44)×9
D34	H4746E8001	Spring bracket	1	1	1	
D35	H4768E8001	Thread releasing plate	1	1	1	
D36	H2404I0034	Screw	1	1	1	9/64 (40) ×8.5
D37	H4748E8001	Lift lever	1	1	1	
D38	H4767E8001	Spring	1	1	1	
D39	H4752E8001	Bracket	1	1	1	
D40	H4749E8001	Screw	1	1	1	11/64 (40) ×8.5
D41	H4715E8001	Bell crank	1	1	1	
D42	H2004J0655	Screw	1	1	1	3/16 (28) ×10
D43	H4717E8001	Roller	1	1	1	

D. UPPER SHAFT & PRESSER FOOT MECHANISM

Fig. No.	Part No.	Description	GC24698-2B	GC24698-BL	GC24698-BR	Remarks
D44	H4718E8001	Screw	1	1	1	11/64(32)×6
D45	H2004J0662	Screw	1	1	1	1/4(40)×5
D46	H4719E8001	Link	1	1	1	
D47	HA100E2150	Screw	2	2	2	11/64 (40) ×10
D48	H4722E8001	Washer	2	2	2	
D49	H4721E8001	Bell crank guide	1	1	1	
D50	H4753E8001	Screw	1	1	1	11/64 (40) ×17.5
D51	H4708D8001	Set screw	2	2	2	1/4(24)×13
D52	H3100G2110	Lifting presser			1	
D52	HF504E8001	Lifting presser		1		
D52	H4762E8001	Lifting presser	1			3/8
D52	H4761E8001	Lifting presser	1			5/16
D53	HE013N8001	Finger gusrd	1			
D53	HE204I8001	Finger gusrd		1	1	

E. TAKE-UP THREAD AND ARM SHAFT MECHANISM

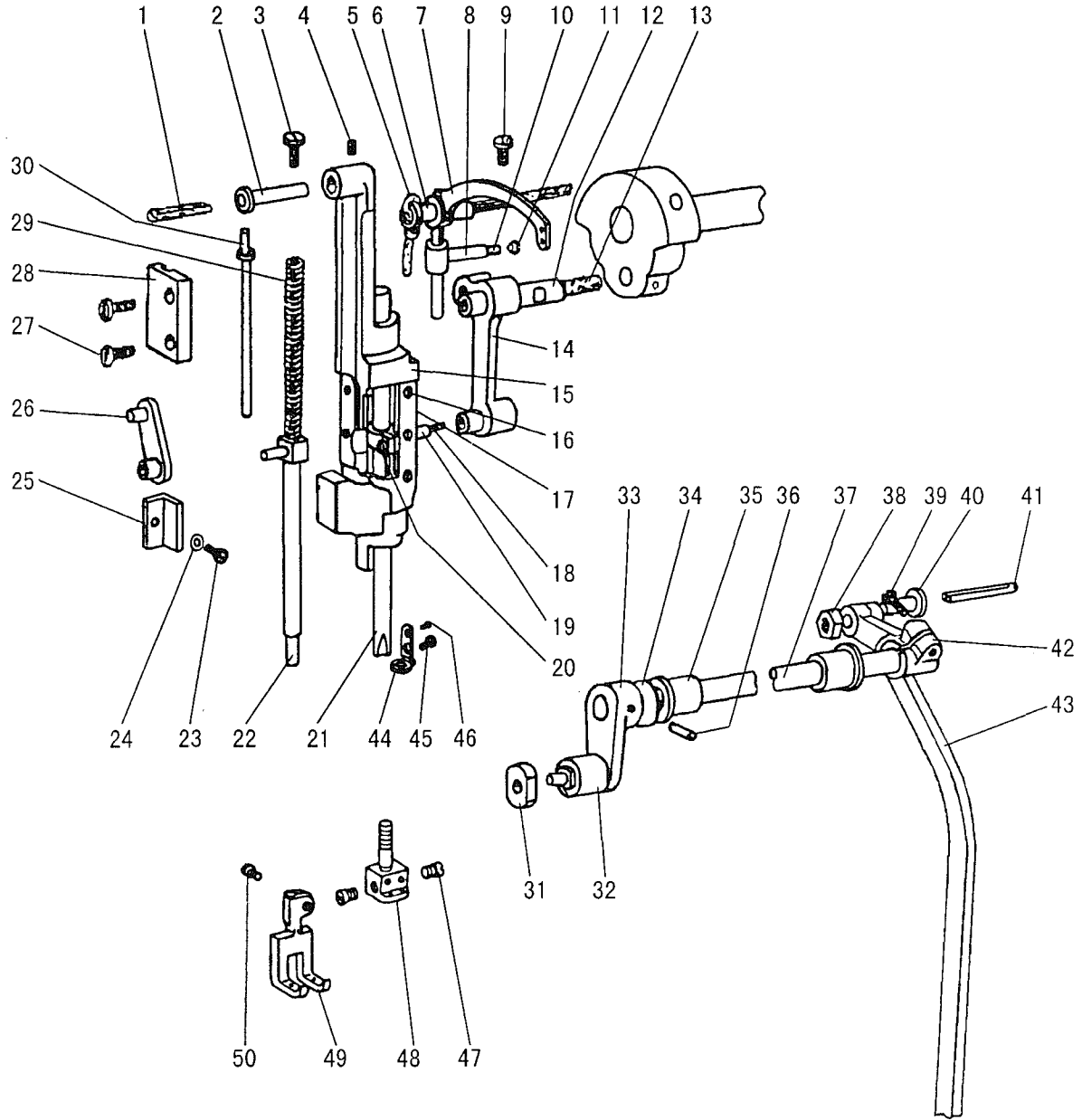

E.TAKE-UP THREAD AND ARM SHAFT MECHANISM

Fig. No.	Part No.	Description	GC24698-2B	GC24698-BL	GC24698-BR	Remarks
E01	H24211DN05	Oil wick	1	1	1	
E02	H4706F8001	Needle bar guide bracket stud	1	1	1	
E03	H4707F8001	Screw	1	1	1	5/16 (28) ×10.4
E04	HA100C2020	Set screw	1	1	1	15/64 (28) ×10
E05	H24211DN05	Oil wick	1	1	1	
E06	H24211DM05	Thread take-up lever support stud	1	1	1	
E07	H4712F8001	Thread take-up lever	1	1	1	
E08	H2405D1112	Thread take-up slide brock	1	1	1	
E09	HA110D0672	Screw	1	1	1	15/64 (28) ×12
E10	H24211D405	Oil wick	1	1	1	
E11	H24211D305	Plug	1	1	1	
E12	H2405D0662	Needle bar crank pin	1	1	1	
E13	H4716F8001	Oil wick	1	1	1	
E14	H4717F8001	Needle bar connecting link	1	1	1	
E15	H4719F8001	Needle bar rock frame	1	1	1	
E16	H32111D304	Screw	6	6	6	3/32 (56) ×4
E17	H4721F8001	Washer	2	2	2	
E18	H3204D6513	Felt	1	1	1	
E19	H4722F8001	Needle bar connecting stud	1	1	1	
E20	H32111D604	Screw	1	1	1	9/64 (40) ×8.5
E21	H4724F8001	Needle bar	1			
E21	H4806F8001	Needle bar		1	1	
E22	H4725F8001	Vibrating presser bar	1	1	1	
E23	H3400C2020	Bolt	1	1	1	
E24	H3200I2030	Washer	1	1	1	
E25	H3400C2010	Needle bar guide	1	1	1	
E26	H4726F8001	Vibrating presser bar link	1	1	1	
E27	H4753E8001	Screw	2	2	2	11/64 (40) ×17.5
E28	H4728F8001	Vibrating presser bar guide	1	1	1	
E29	H4729F8001	Spring	1	1	1	
E30	H4730F8001	Vibrating presser spring guide	1	1	1	
E31	H3410C301P	Square block	1	1	1	
E32	H3406C0671	Screw	1	1	1	15/64(28)×10
E33	H3406C0672	Needle bar vibrating crank(left)	1	1	1	
E34	H4734F8001	Washer	1	1	1	
E35	H3204B0652	Bushing	2	2	2	
E36	H602040240	Taper pin	1	1	1	
E37	H4736F8001	Needle bar vibrating shaft	1	1	1	
E38	H7107F8001	Nut	1	1	1	
E39	H2012N0652	Screw	1	1	1	1/4 (24) ×16
E40	H7108F8001	Screw	1	1	1	5/16 (24) ×5
E41	H32311D406	Oil wick	1	1	1	
E42	H7104F8001	Needle bar vibrating crank(right)	1	1	1	

E.TAKE-UP THREAD AND ARM SHAFT MECHANISM

Fig. No.	Part No.	Description	GC24698-2B	GC24698-BL	GC24698-BR	Remarks
E43	H7105F8001	Connecting link	1	1	1	
E44	H3129F0693	Thread guide		1	1	
E45	HA100C2170	Screw		1	1	1/8 (44) ×4.5
E46	H3129F0691	Screw		1	1	3/32 (56) ×2.5
E47	H32132D104	Screw	2			9/64 (40) ×3
E48	H4754F8001	Needle clamp (3/8 ")	1			3/8
E48	H4753F8001	Needle clamp (5/16 ")	1			5/16
E49	H4745F8001	Vibrating presser foot	1			3/8
E49	H4744F8001	Vibrating presser foot	1			5/16
E49	H4807F8001	Vibrating presser foot		1	1	
E50	HA700F2100	Screw	1	1	1	11/64 (40) ×7

F. STITCH REGULATOR MECHANISM

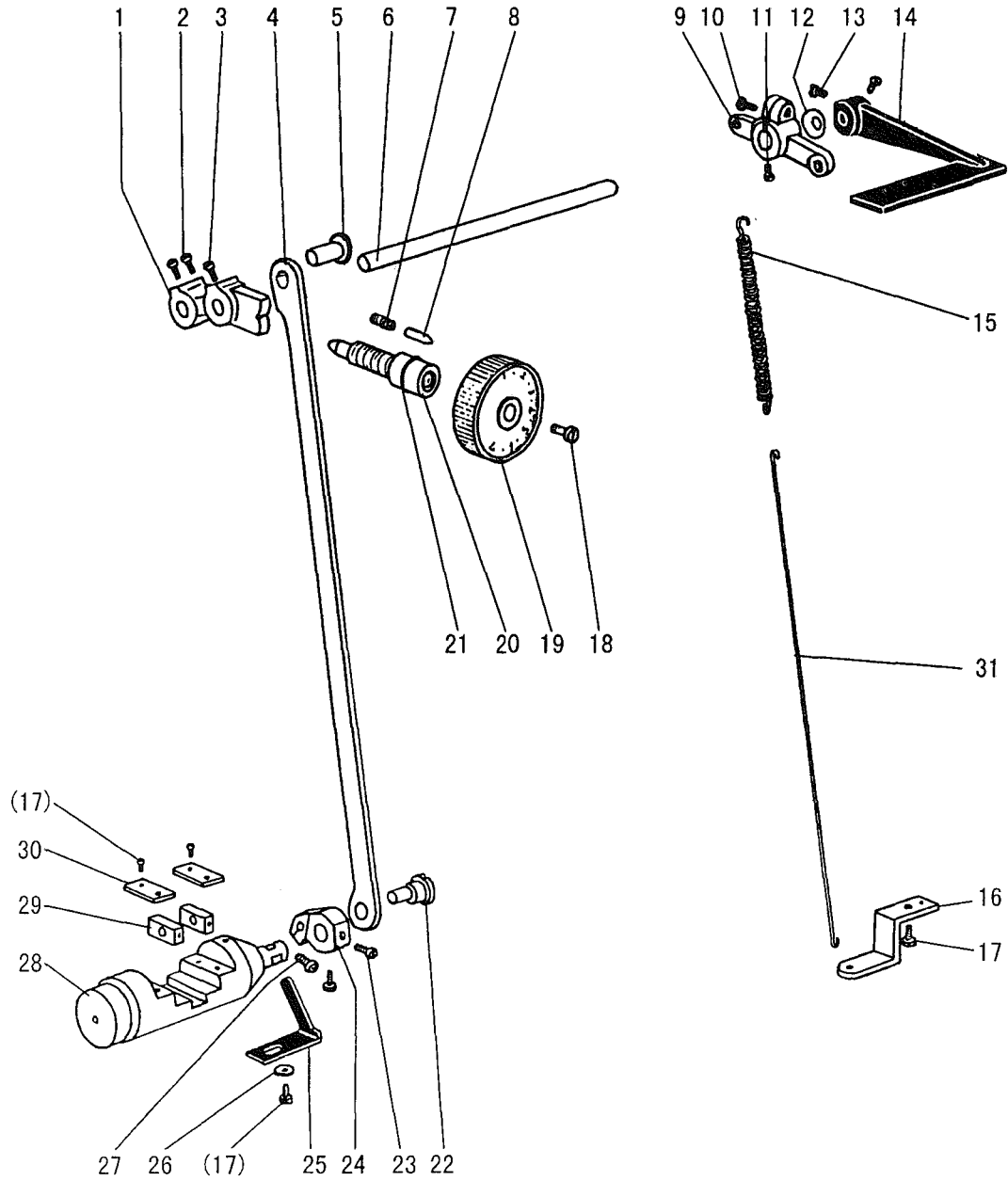

F.LOWER SHAFT & FEED ROCK SHAFT MECHANISM

Fig. No.	Part No.	Description	GC24698-2B	GC24698-BL	GC24698-BR	Remarks
F01	H6309F8001	Feed regulator	1	1	1	
F02	HA113F0684	Screw	2	2	2	15/64 (28) ×8.5
F03	H3200F2020	Screw	1	1	1	15/64 (28) ×12
F04	HB8251F081	Link	1	1	1	
F05	HA100G2070	Eccentric shaft	1	1	1	
F06	H0204G8001	Reverse stitch shaft	1	1	1	
F07	H3200F2110	Spring	1	1	1	
F08	HA100F2080	Stopper pin	1	1	1	
F09	H3207F0671	Reverse stitch crank	1	1	1	
F10	HA800F2020	Screw	1	1	1	15/64 (28) ×13.5
F11	H3207F0672	Screw	1	1	1	11/64 (40) ×8.5
F12	HA100F2110	Washer	1	1	1	
F13	HA113F0684	Screw	2	2	2	15/64 (28) ×8.5
F14	H4711G8001	Feed reversing lever	1	1	1	
F15	H3207F0673	Spring	1	1	1	
F16	H3200F2050	Bracket for spring	1	1	1	
F17	HA300C2030	Screw	4	4	4	11/64 (40) ×8
F18	HA109F0673	Screw	1	1	1	3/16 (28) ×8.6
F19	H3304F0652	Dial	1	1	1	
F20	HA109F0671	Screw bar	1	1	1	T7/16 (8) ×54.3
F21	HA109F0674	O-ring	1	1	1	
F22	H3206F0662	Pin	1	1	1	
F23	H3210F0681	Screw	2	2	2	M5×6
F24	H3210F0683	Reverse stitch shaft crank	1	1	1	
F25	H3200F2080	Holding plate	1	1	1	
F26	HA703R0067	Washer	1	1	1	
F27	H3210F0682	Screw	1	1	1	M5×14
F28	H3212F0692	Reverse bar	1	1	1	
F29	H3208G0672	Square block	2	2	2	
F30	H3212F0691	Guide plate	2	2	2	
F31	H7105G8001	Spring hook	1	1	1	

G. LOWER SHAFT & FEED ROCK SHAFT MECHANISM

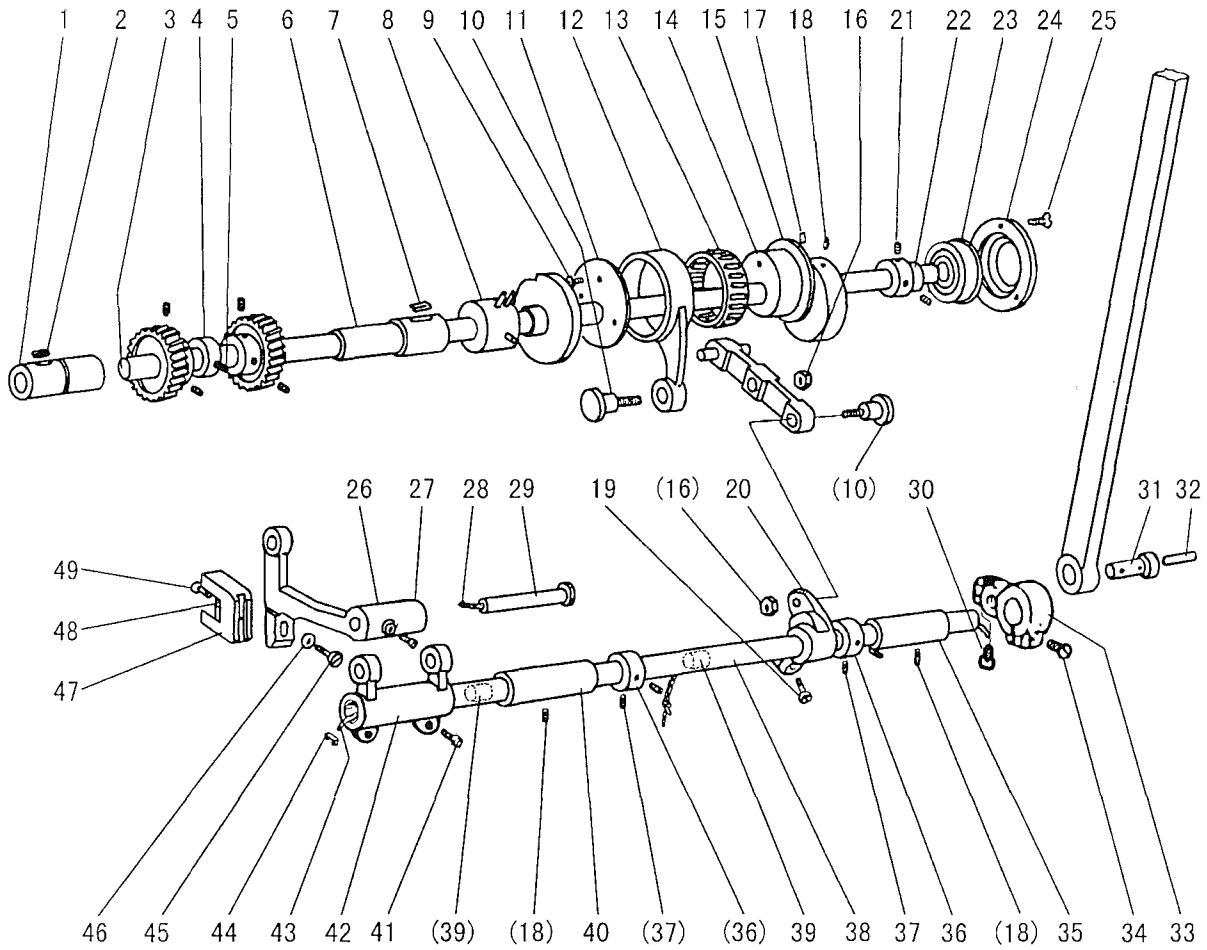

G.LOWER SHAFT & FEED ROCK SHAFT MECHANISM

Fig. No.	Part No.	Description	GC24698-2B	GC24698-BL	GC24698-BR	Remarks
G01	H6315B8001	Lower shaft bushing(left)	1	1	1	
G02	H32132B204	Oil wick	1	1	1	
G03	H0204H8001	Lower shaft	1	1	1	
G04	H3205H0655	Feed lifting cam	1	1	1	
G05	H3205H0654	Set screw	1	1	1	1/4(40)×5
G06	H6317B8001	Lower shaft bushing(right)	1	1	1	
G07	H32132B204	Oil wick	1	1	1	
G08	H3204B0054	Lower shaft bushing(middle)	1	1	1	
G09	HA700F2100	Screw	3	3	3	11/64 (40) ×7
G10	H3208G0674	Screw	2	2	2	1/4 (24) ×15
G11	H32372G208	Washer	1	1	1	
G12	H32372G408	Feed connecting rod	1	1	1	
G13	H32372G308	Needle bearing	1	1	1	
G14	H3305G1011	Lever feed connecting cam	1	1	1	
G15	H3208G2011	Link	1	1	1	
G16	H3208G0675	Nut	2	2	2	
G17	H2405D0664	Set screw	1	1	1	15/64 (28) ×14
G18	H3208G0676	Screw	3	3	3	15/64 (28) ×14
G19	H3208G0676	Screw	1	1	1	15/64 (28) ×14
G20	H3208G0673	Connecting rod crank(middle)	1	1	1	
G21	HA105D0662	Set screw	2	2	2	1/4 (40) ×4
G22	H3208H0662	Bushing	1	1	1	
G23	H3208H0661	Ball bearing	1	1	1	
G24	H3200H2060	Bearing holder	1	1	1	
G25	HA7311C306	Screw	3	3	3	9/64 (40) ×7
G26	H6305G8001	Feed bar	1	1	1	
G27	H429050050	Screw	1	1	1	
G28	H3205G0662	Oil wick	1	1	1	
G29	H32243G205	Feed bar shaft	1	1	1	
G30	HA104G0012	Screw	1	1	1	3/16 (28) ×12
G31	H3407C0664	Pin	1	1	1	
G32	H24211D405	Oil wick	1	1	1	
G33	H3407C0663	Connecting rod crank(right)	1	1	1	
G34	H2012N0652	Screw	1	1	1	1/4 (24) ×16
G35	H3204B0656	Feed rock shaft bushing(right)	1	1	1	
G36	HA108G0066	Collar	2	2	2	
G37	HA105D0662	Screw	4	4	4	1/4 (40) ×4
G38	H3204G0651	Feed rock shaft	1	1	1	
G39	H3204G0652	Felt	2	2	2	
G40	HA100G2120	Feed rock shaft bushing(left)	1	1	1	
G41	HA104G0012	Screw	2	2	2	3/16 (28) ×12
G42	H3205G1032	Feed rock shaft crank(left)	1	1	1	
G43	H3204G0031	Oil wick	1	1	1	

G.LOWER SHAFT & FEED ROCK SHAFT MECHANISM

Fig. No.	Part No.	Description	GC24698-2B	GC24698-BL	GC24698-BR	Remarks
G44	H3200G2030	Holder	1	1	1	
G45	H3200H2040	Bolt	1	1	1	
G46	H2013J0065	Washer	1	1	1	
G47	H3205H0651	Feed bar connecting fork	1	1	1	
G48	H3205H0652	Felt	1	1	1	
G49	H3205H0653	Screw	1	1	1	1/8 (44) ×4

H. HOOK SADDLE MECHANISM

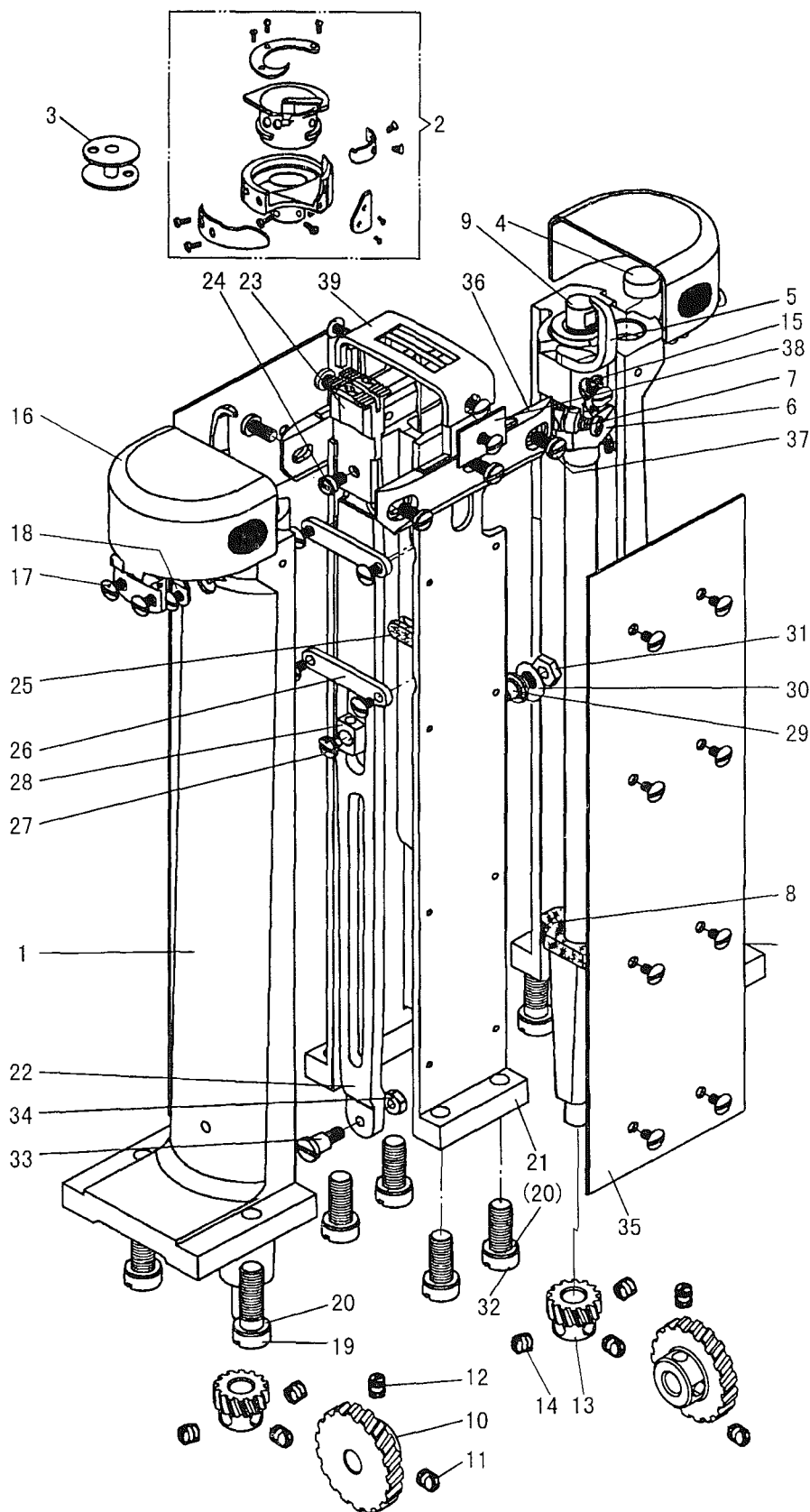

H. HOOK SADDLE MECHANISM

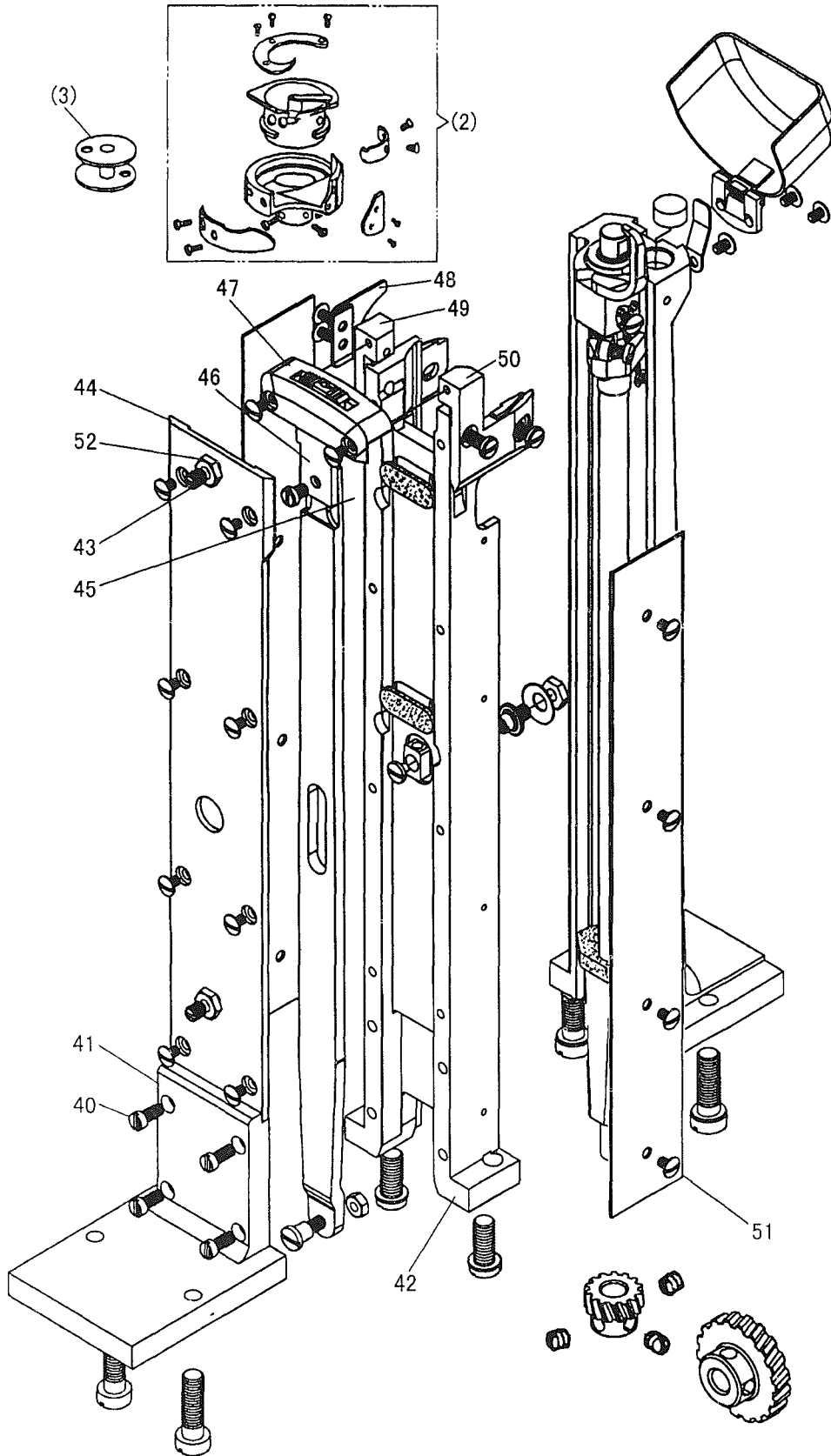

H.HOOK SADDLE MECHANISM

Fig. No.	Part No.	Description	GC24698-2B	GC24698-BL	GC24698-BR	Remarks
H01	HB8251I081	Hook saddle	2	1	1	
H02	HD804I7101	Hook	2	1	1	
H03	HD806I8001	Bobbin	2	1	1	
H04	HE511J8001	Felt	2	1	1	
H05	HE512J8001	Opener	2	1	1	
H06	HE513J8001	Crank	2	1	1	
H07	HE022K8001	Screw	2	1	1	11/64 (32) ×9
H08	HE514J8001	Felt	2	1	1	
H09	HB8254I081	Hook shaft	2	1	1	
H10	H32142I104	Gear(large)	2	1	1	
H11	HA307C0662	Set screw	2	1	1	1/4 (40) ×6
H12	H3204I6510	Set screw	2	1	1	1/4(40)×6.5
H13	H32142I204	Gear (small)	2	1	1	
H14	HA105D0662	Set screw	6	3	3	1/4 (40) ×4
H15	HE516J8001	Oil wick	2	1	1	
H16	HE518J7101	Slide plate	2	1	1	
H17	HE517J8001	Screw	32	24	24	9/64 (40) ×5.5
H18	HE524J8001	Spring plate	2	1	1	
H19	HE525J8001	Screw	4	4	4	5/16 (20) ×26
H20	H005001080	Washer	8	6	6	
H21	HB8256I081	Feed bar set bracket	1			
H22	HB8258I081	Feed bar	1	1	1	
H23	HE531J8001	Feed dog	1			
H24	HE012E8001	Screw	1			11/64 (32) ×6.5
H25	HE532J8001	Felt	2			
H26	HE533J8001	Support plate	2			
H27	HE123I8001	Screw	1	1	1	1/8 (44) ×4
H28	HE535J8001	Square block	1	1	1	
H29	HE536J8001	Screw	1	1	1	7/32 (32) ×4.5
H30	HE045D8001	Washer	1	1	1	
H31	HE021B8001	Nut	1	1	1	
H32	HE538J8001	Screw	4	2	2	5/16 (20) ×18
H33	H0204I8001	Screw	1	1	1	3/16 (32) ×7.5
H34	HE540J8001	Nut	1	1	1	
H35	HB8259I081	Cover plate	2			
H36	HE542J8001	Hook support bracket	2			
H37	HE543J8001	Screw	6	4	4	3/16 (32) ×9.5
H38	HE544J8001	Plate	2			
H39	HE545J8001	Needle plate	1			
H40	HE416I8001	Screw		4	4	11/64 (32) ×14
H41	HE408I8001	Support plate		1	1	
H42	HB9252I081	Feed bar set bracket		1	1	
H43	HE028E8001	Screw		2	2	7/32 (32) ×7

H.HOOK SADDLE MECHANISM

Fig. No.	Part No.	Description	GC24698-2B	GC24698-BL	GC24698-BR	Remarks
H44	HB9251I081	Cover plate		1	1	
H45	HE410I8001	Felt		2	2	
H46	HE409I8001	Feed dog			1	
H46	HF504I8001	Feed dog		1		
H47	HE411I8001	Needle plate		1	1	
H48	HE406I8001	Cover plate		1	1	
H49	HE405I8001	Needle plate support bracket		1	1	
H50	HE404I8001	Needle plate support bracket		1	1	
H51	HB9253I081	Cover plate		2	2	
H52	HE021B8001	Nut		2	2	

I. OIL LUBRICATION MECHANISM

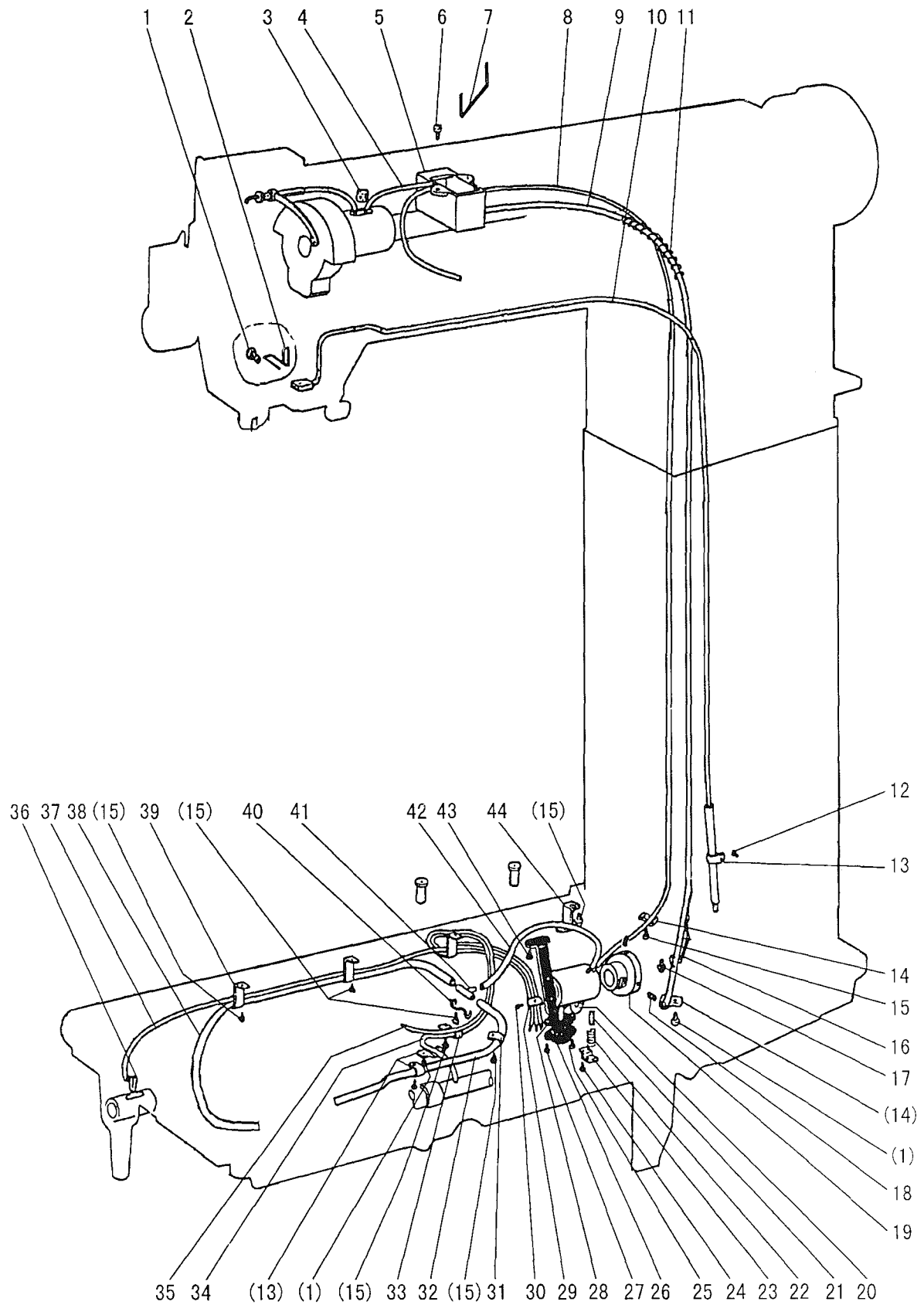

I.OIL LUBRICATION MECHANISM

Fig. No.	Part No.	Description	GC24698-2B	GC24698-BL	GC24698-BR	Remarks
I01	HA300C2030	Screw	3	3	3	11/64 (40) ×8
I02	H4731J8001	Holder	1	1	1	
I03	H32175B304	Felt	1	1	1	
I04	H4705J7101	Oil pipe & wick complete	1	1	1	
I05	H3204K0011	Oil tank complete	1	1	1	
I06	H411040160	Screw	2	2	2	
I07	H4707J8001	Holder	1	1	1	
I08	H7109K8001	Oil pipe	1	1	1	
I09	H7110K8001	Oil pipe	1	1	1	
I10	H7111K7101	Oil pipe complete	1	1	1	
I11	H4710J8001	Spring	2	2	2	
I12	HA7311CC06	Screw	7	7	7	9/64 (40) ×6.5
I13	H2000M0110	Holder	1	1	1	
I14	H3200K0190	Holder	2	2	2	
I15	HA300B2130	Screw	6	6	6	11/64 (40) ×5.5
I16	H3200K0200	Holder	1	1	1	
I17	HA300B2170	Screw	1	1	1	11/64 (40) ×9
I18	H3230K0751	Set screw	2	2	2	11/64 (40) ×10
I19	H0209K8001	Bushing	1	1	1	
I20	H3215K0696	Oil pipe	1	1	1	
I21	H1100I2070	Plunger	1	1	1	
I22	H1100I2090	Coil spring	1	1	1	
I23	H1100I2110	Guide plate	1	1	1	
I24	H3204D6510	Screw	1	1	1	1/8 (44) ×4.8
I25	H3215K0693	Screw	1	1	1	9/64 (40) ×5
I26	H3215K0692	Filter	1	1	1	
I27	H3215K0694	Screw	1	1	1	9/64 (40) ×7
I28	H3215K4011	Base plate complete	1	1	1	
I29	H3215K0695	Holder	1	1	1	
I30	HA106B0676	Screw	1	1	1	9/64 (40) ×6
I31	H32311D606	Holder	1	1	1	
I32	H3210K0672	Oil pipe	1	1	1	
I33	H3200K0170	Holder	1	1	1	
I34	H3218K0072	Oil pipe complete	1	1	1	
I35	H3217K0071	Oil pipe complete	1	1	1	
I36	H3200K0180	Oil wick	1	1	1	
I37	H3216K0070	Oil pipe complete	1	1	1	
I38	H3204K0655	Oil pipe	1	1	1	
I39	H3200K0160	Holder	3	3	3	
I40	H3210K0674	Holder	1	1	1	
I41	H3210K0671	Oil pipe connector	1	1	1	
I42	H3210K0673	Oil pipe	1	1	1	
I42	H6204K8001	Oil pipe	1	1	1	

I.OIL LUBRICATION MECHANISM

Fig. No.	Part No.	Description	GC24698-2B	GC24698-BL	GC24698-BR	Remarks
143	HA100E2150	Screw	1	1	1	11/64 (40) ×10
144	H3200K0250	Holding plate	1	1	1	

J. ACCESSORIES

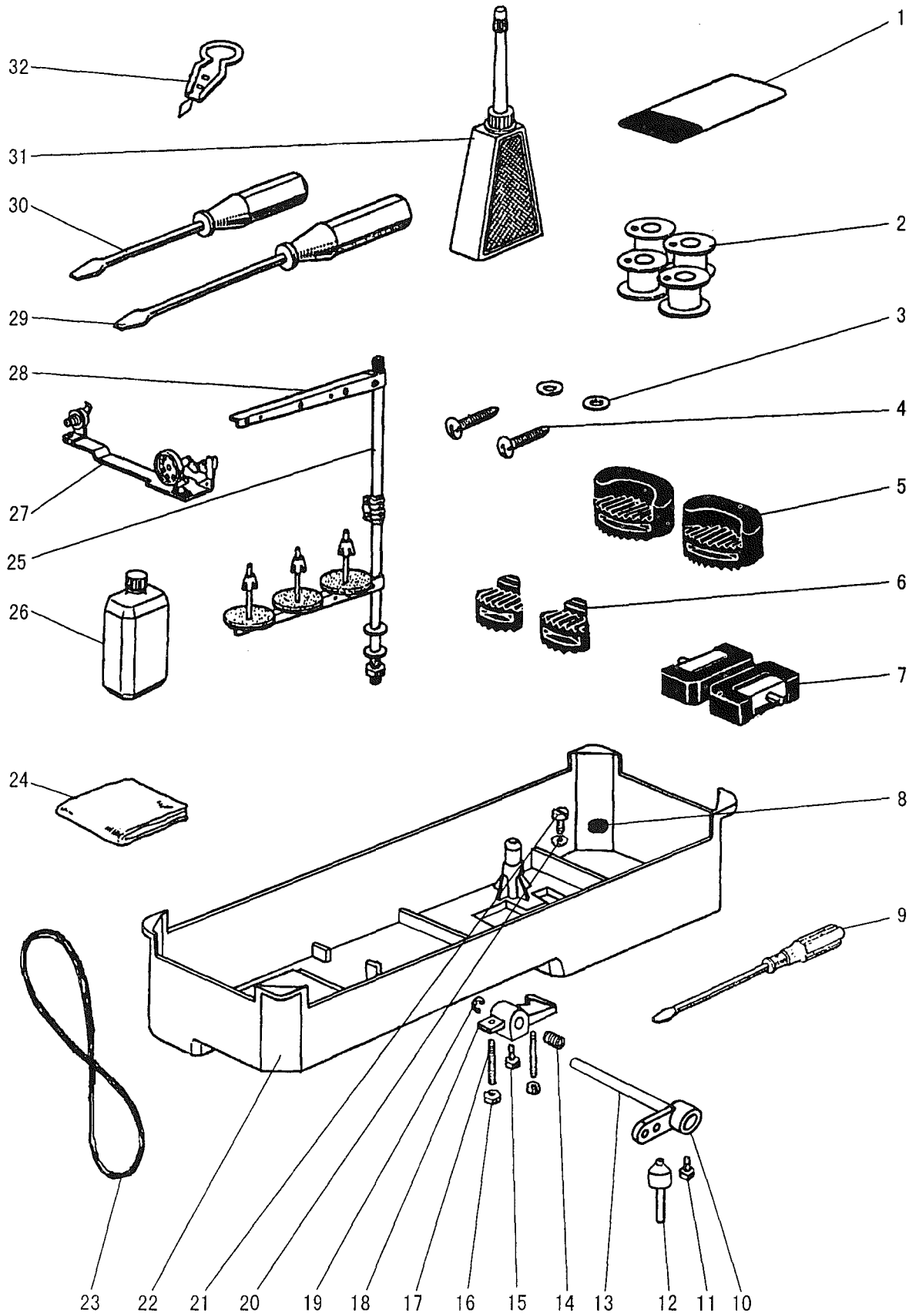

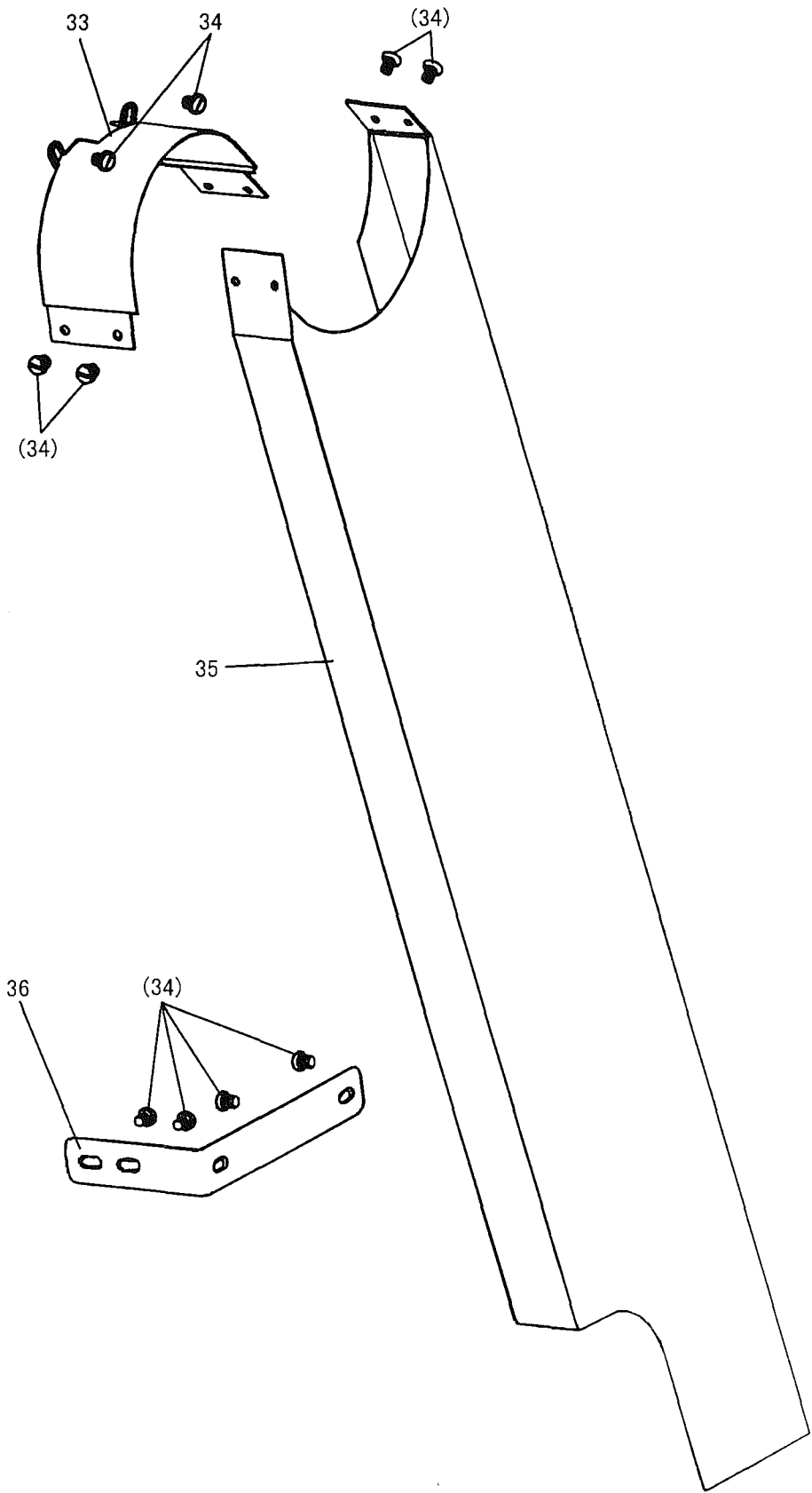

J.ACCESSORIES

Fig. No.	Part No.	Description	GC24698-2B	GC24698-BL	GC24698-BR	Remarks
J01	H4740F8001	Needle	1	1	1	DP×17 23#
J02	HD806I8001	Bobbin	4	2	2	
J03	HA300J2230	Washer	4	4	4	
J04	H801045200	Wood screw	4	4	4	
J05	H3200L0020	Vibration preventing rubber	2	2	2	
J06	H3200L0030	Vibration preventing rubber	2	2	2	
J07	HA307J0067	Hinge complete	2	2	2	
J08	HA100J2120	Magnet	1	1	1	
J09	HA300J2070	Screw driver (larger)	1	1	1	
J10	H7122L8001	Crank	1	1	1	
J11	HA106J0664	Screw	1	1	1	
J12	H3214L2011	Knee lifter pin	1	1	1	
J13	H3213L0662	Knee lifter shaft	1	1	1	
J14	HA104J0657	Spring	1	1	1	
J15	HA104J0659	Screw	2	2	2	15/64 (28) ×28
J16	HA104J6510	Nut	2	2	2	
J17	HA106J0664	Screw	1	1	1	15/64 (18) ×13
J18	H3213L0664	Knee lifter crank	1	1	1	
J19	H007013090	E-type ring	1	1	1	
J20	HA104J0653	Washer	1	1	1	
J21	HA104J0652	Screw	1	1	1	5/16 (28) ×10
J22	H3213L0661	Oil reservoir	1	1	1	
J23	H7116L8001	M-type belt	1	1	1	
J24	H7114L8001	Vinyl cover	1	1	1	
J25	H7112L8001	Cotton stand pipe	1	1	1	
J26	H3200L0130	Oil tank	1	1	1	
J27	HA706S0067	Bobbin winder	1	1	1	
J28	H3200L0120	Cotton stand	1	1	1	
J29	HA100J2140	Screw driver(middle)	1	1	1	
J30	HA100J2150	Screw driver (small)	1	1	1	
J31	HA100J2110	Oiler	1	1	1	
J32	H3207L0065	Thread a needle kit	1	1	1	
J33	H2008O0068	Belt cover (upper)	1	1	1	
J34	HA300B2170	Screw	10	10	10	
J35	H7115L8001	Belt cover	1	1	1	
J36	H7123L8001	Belt cover stand	1	1	1	

SHANGHAI HUIGONG NO.3 SEWING MACHINE FACTORY

ADD: 1418, Yishan Road, Shanghai, China

Zip Code: 201103

Overseas Business: TEL: 86-21-64853303 FAX: 86-21-64854304

E-mail: highlead@online.sh.cn <http://www.highlead.com.cn>

The description covered in this manual is subject to change for improvement of the commodity without notice

2004.5. Printed

From the library of: Superior Sewing Machine & Supply LLC