

Purchasing Dept  
Copy

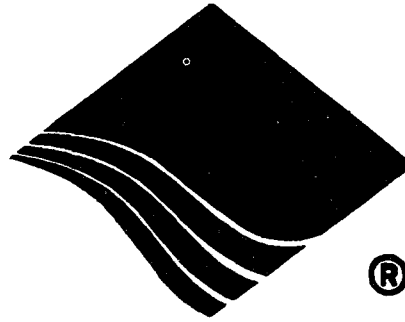

**HIGHLEAD**

**GC24518-1/GC24518-2**

**Single-Needle.Double-Needle Post Bed Needle Feed  
Lockstitch Sewing Machine**

**Instruction Manual  
Parts Catalog**

**SHANGHAI HUIGONG NO.3 SEWING MACHINE FACTORY**

From the library of: Superior Sewing Machine & Supply LLC



# --- CONTENTS ---

## Instruction Manual

1、Precautions before starting operation .....	1
2、How to Attach Needle .....	2
3、How to Wind the Lower Thread .....	2
4、Lead the Upper Thread .....	2
5、Adjustment of stitch length and reverse sewing .....	2
6、Adjust the thread guide .....	3
7、Adjust the pressure of presser foot .....	3
8、How to place the bobbin into the hook .....	3
9、How to lead the lower thread .....	3
10、How to adjust the lower thread .....	4
11、Adjustment of upper thread .....	4
12、Adjustment of the thread tension .....	4
13、Adjusting thread take-up spring .....	4
14、Lubrication .....	5
15、Installation of belt cover .....	5

## Parts Catalog

A、ARM BED AND ITS ACCESSORIES .....	6
B、THREAD TENSION REGULATOR MECHANISM .....	8
C、UPPER SHAFT & PRESSER FOOT MECHANISM .....	11
D、THRED TAKE-UP LEVER & NEEDLE BAR MECHANISM .....	14
E、STICH REGULATOR MECHANISM .....	16
F、LOWER SHAFT & FEED ROCK SHAFT MECHANISM .....	18
G、HOOK SADDLE MECHANISM .....	21
H、OIL LUBRICATION MECHANISM .....	24
I、ACCESSORIES .....	27
OTHER REPLACEMENT PARTS .....	30



# 1. Precautions before starting operation

## 1) Safety precautions:

(1) When turning the power on, keep your hands and fingers away from the area around/under the needle and the area around the pulley.

(2) Power must be turned off when the machine is not in use, or when the operator leaves the seat.

(3) Power must be turned off when tilting the machine head, installing or removing the “V” belt, adjusting the machine, or when replacing.

(4) Avoid placing fingers, hairs, bars etc., near the pulley, “V” belt, bobbin winder pulley, or motor when the machine is in operation.

(5) Do not insert fingers into the thread take-up cover, under/around the needle, or pulley when the machine is in operation.

(6) If a belt cover, finger guard, eye guard are installed, do not operate the machine without these safety devices.

## 2) Precautions before starting operation:

(1) If the machine’s oil pan has an oil sump, never operate the machine before filling it.

(2) If the machine is lubricated by a drop oiler, never operate the machine before lubricating.

(3) When a new sewing machine is first turned on, verify the rotational direction of the pulley with the power on. (The pulley should rotate counterclockwise when viewed from the pulley)

(4) Verify the voltage and (single or three) phase with those given on the machine nameplate.

## 3) Precautions for operating conditions:

1) Avoid using the machine at abnormally high temperatures (35°C or higher) or low temperatures (5°C or lower)

2) Avoid using the machine in dusty conditions.

## 4) Specifications:

Model		GC24518-2	GC24518-1
Specifications			
Sewing Material		Medium-heavy Material	
Max Speed (rpm)		2500	
Stitch Length (mm)		0-5	
Needle Bar Stroke (mm)		33.4	
Presser Foot	By Hand	7.0	
Stroke (mm)	By Knee	10.0	
Hook		Standard Hook	
Stitch Length Adjustment		Dial	
Lubrication System		Automatic	
Needle		DP×5 16#	
Motor		Clutch Motor	
Gauge		2.4 2.0	

## 2.How to Attach Needle (Fig.1):

Note: Before using the following procedures, be sure to turn the power switch off.

- 1).Loosen the needle clamping screw;
- 2).Hold the needle to its side with the long groove side toward left, and insert it as deeply it will go into the needle clamping hole.(GC24518-1);Hold the needles so that the two needles side with the long grooved face to face, and insert it as deeply it will go into the needle clamping hole.(GC24518-2);
- 3).Tighten the needle clamping screw.

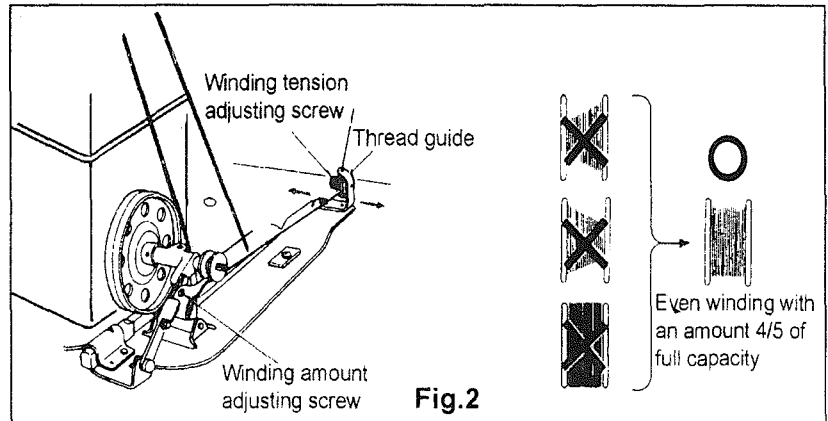
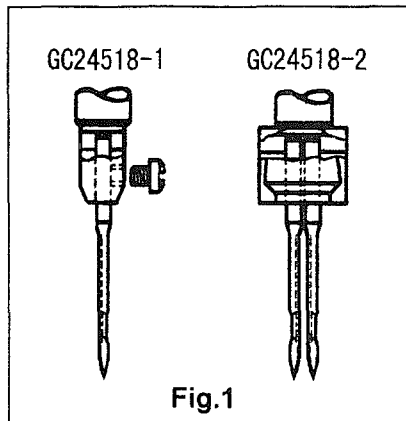

## 3.How to Wind the Lower Thread ( Fig. 2 ):

Strength of winding: Particularly in the case of nylon or polyester thread, wind the bobbin loosely.

Uneven winding: If the bobbin is wound unevenly, slide the thread guide toward the less wound portion of bobbin.

Winding amount: When the bobbin is wound excessively, loosen the adjusting screw. When the bobbin is insufficiently tighten the adjusting screw.

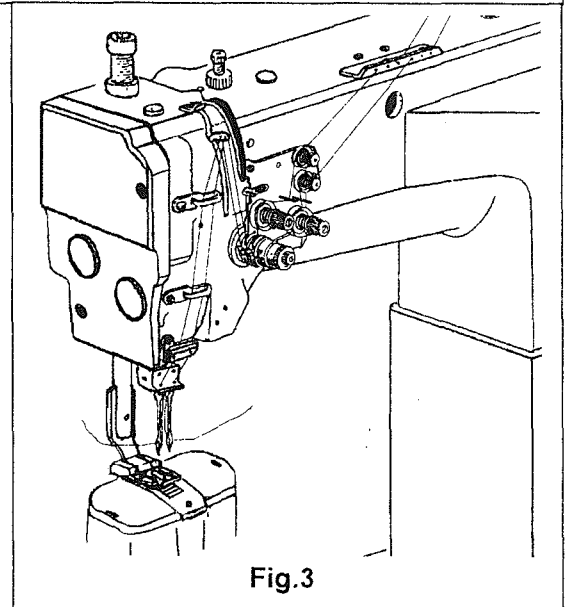

## 4.Lead the Upper Thread ( Fig.3 ) :

Raise the thread take-up lever to its highest position and lead the upper thread as shown in fig.3.

## 5.Adjustment of stitch length and reverse sewing

(Fig.4):

- a) Stitch length can be adjusted by turning Dial;
- b) The figures on Dial Plate show stitch length in mm;

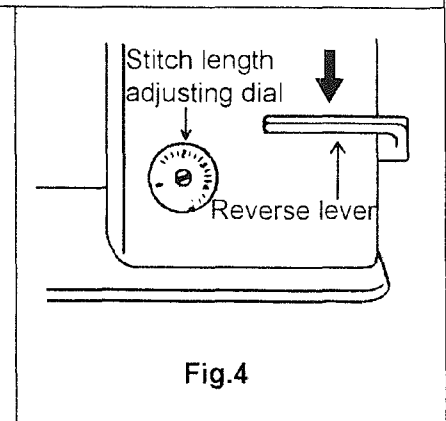

c) Reverse feeding starts when Reverse Feed Lever is depressed, and the machine will feed forward again if Reverse Feed Lever is released.

## 6.Adjust The Thread Guide(List.1):

The position of the thread guide affects stitch tightness, and therefore must be adjusted according to sewing materials and sewing conditions.

## 7.Adjust the Pressure of Presser Foot

( Fig.5):

As shown in Fig.5, Turn the pressure regulating thumb screw to increase or decrease the pressure of presser foot.

## 8.How to place the Bobbin into the Hook ( Fig.6):

Pull the bobbin thread about 5cm, Hold the bobbin as shown in fig.6, then place the bobbin into the hook base.

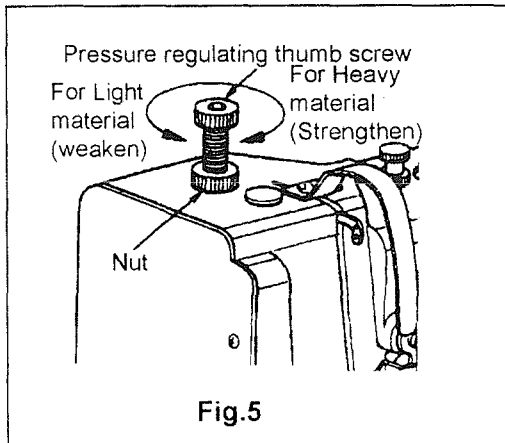

Thread guide position	Leftward	Center	Rightward
Material weight	Heavy	Medium	Light
Supply	More	Standard	Less

**List.1**

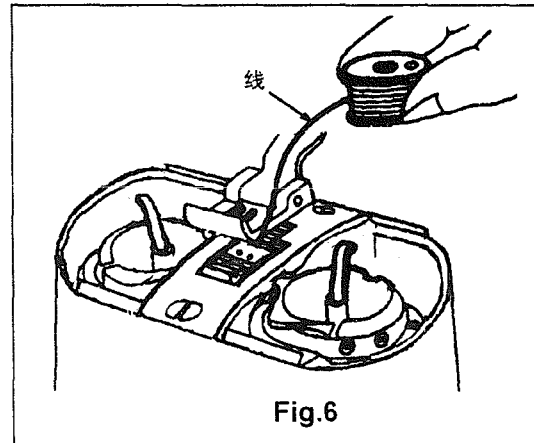

## 9.How to lead the lower thread (Fig.7、 Fig.8):

1) As shown in fig.7, from the slit (1) pass the thread underneath the hook body, and pull it to the right diagonally, and thread will pass through the tension spring (single needle); From the slit (1) pass the thread underneath the hook body, and pull the left thread to the left and the right thread to the right diagonally, and thread will pass through the tension spring (double needle).

2) As shown in fig.8, holding the end of upper thread by left hand, turn the balance wheel slowly one around by right hand, the upper thread will hook out pulling the lower thread simultaneously through the hole of needle plate, and leave the lower thread to the other side of the needle plate. Close the slide plate.

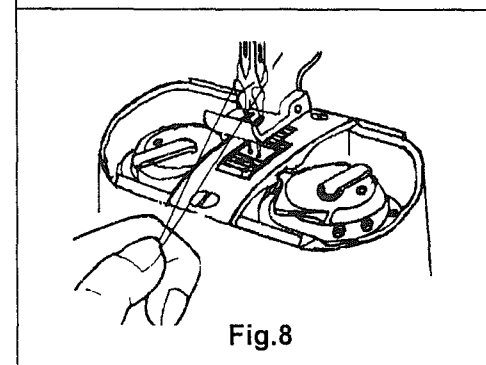
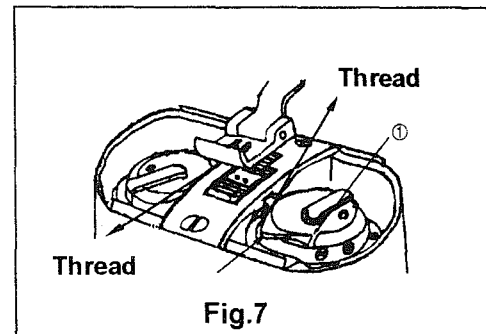

## 10. How to adjust the lower thread ( Fig.9):

The lower thread tension can be adjusted by rotating the screw 2, turn the screw 2 clock-wise for more tension, or turn the screw 2 counter-clockwise for less tension.

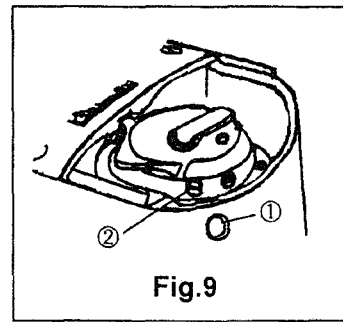

Fig.9

## 11. Adjustment of upper thread ( Fig.10):

Turn the Thread Tension Nut left or right to loosen or tighten the pressure of upper thread.

## 12. Adjustment of the thread tension ( Fig.11):

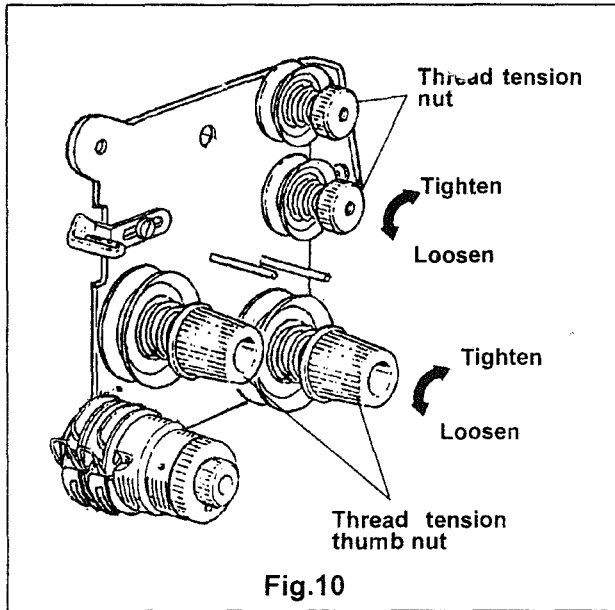

Fig.10

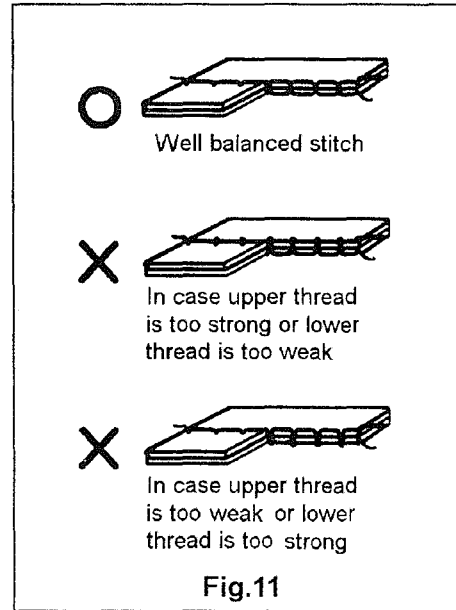

Fig.11

## 13. Adjusting thread take-up spring ( Fig.12 )

1) Adjusting the thread take-up spring stroke:

a. Thread take-up spring for left upper thread 1: Loosen the screw 2, adjusting the stopper block 3.

b. Thread take-up spring for right upper thread 4: Loosen the screw 5, adjusting the stopper block 6.

2) Adjusting the thread take-up spring tension:

a. Thread take-up spring tension

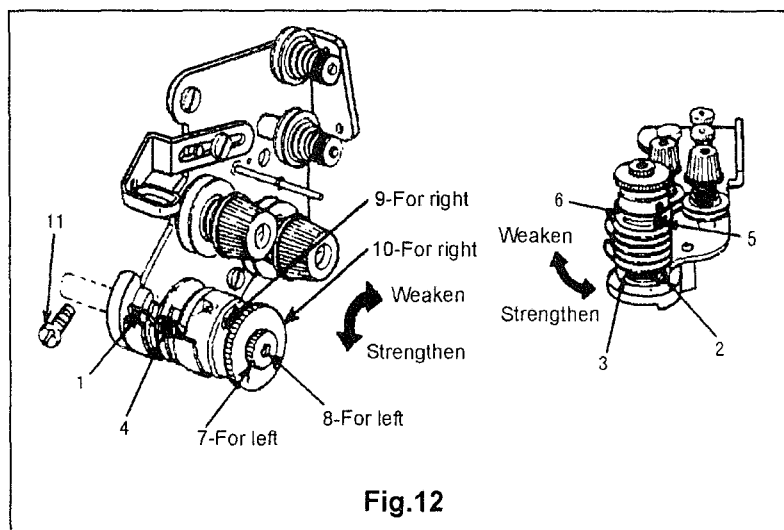

Fig.12

for left upper thread: Loosen the nut 7 and screw 11, then adjusting the tension screw. After adjustment, tighten



the nut 7 and screw 11.

b. Thread take-up spring tension for right upper thread: Loosen the screw 9, adjusting the nut 10. After adjustment, tighten screw 9

#### 14. Lubrication ( Fig.13、 Fig.14、 Fig.15):

1) Before starting operation, be sure to pour oil up to the position H of oil tank. If the oil below position L, replenish the oil supply up to position H. ( Fig.13 )

2) When a new sewing machine is first operated, or when a sewing machine which left out of use for a long period of time is operated, it will be necessary to oil through the oilholes after removing the rubber plugs shown below

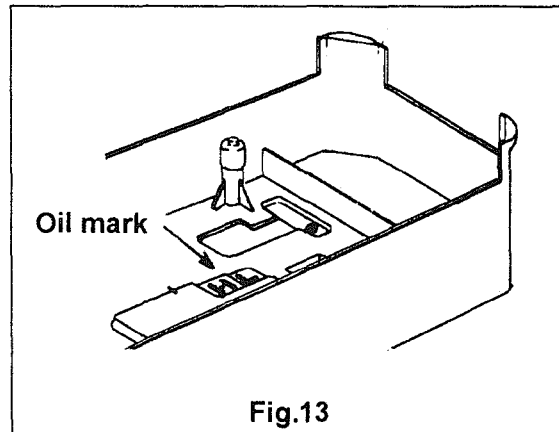

Fig.13

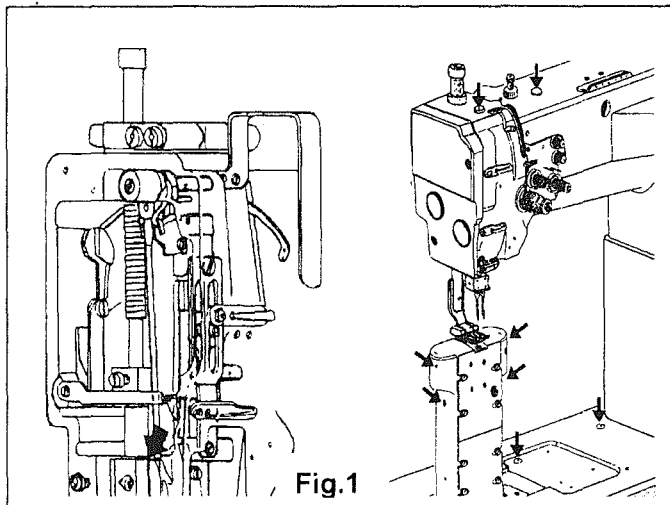

Fig.1

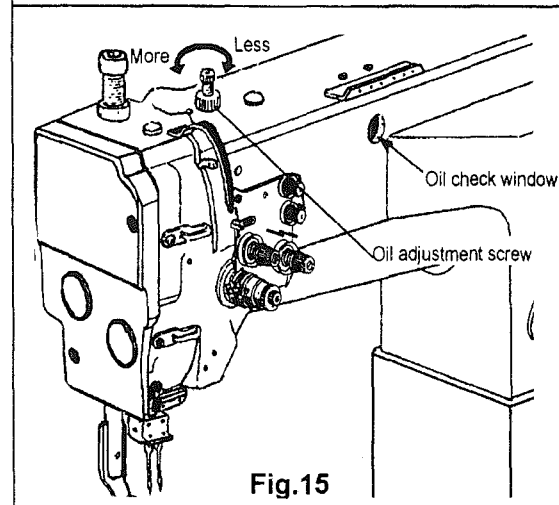

Fig.15

(the direction shown in arrows). ( Fig. 14 )

3) While operating the machine, check the condition of oil lubrication through the oil check window. The oil amount can be adjusted by oil adjustment screw. ( Fig.15 )

#### 15. Installation of Belt cover ( Fig.16 ):

Set the screws 4、 6 and the washer 7 on the arm as illustrated. Assemble the belt guard 3 in the direction of the arrow, tighten it's screw. The assembling of the belt guard 5 is the same as the belt guard 3, then, insert the belt guard 1 from the top of the pulley into the inside of the 3 and 5, tighten the screws 2 .

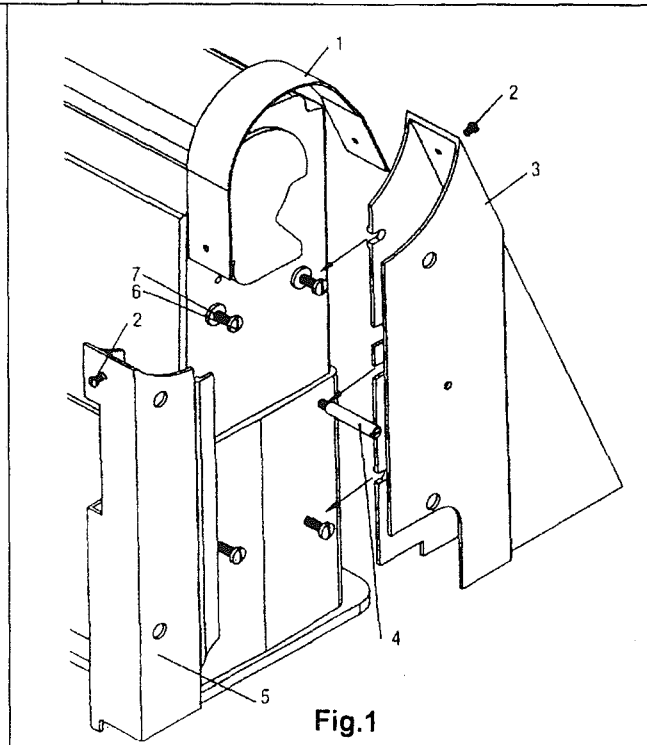
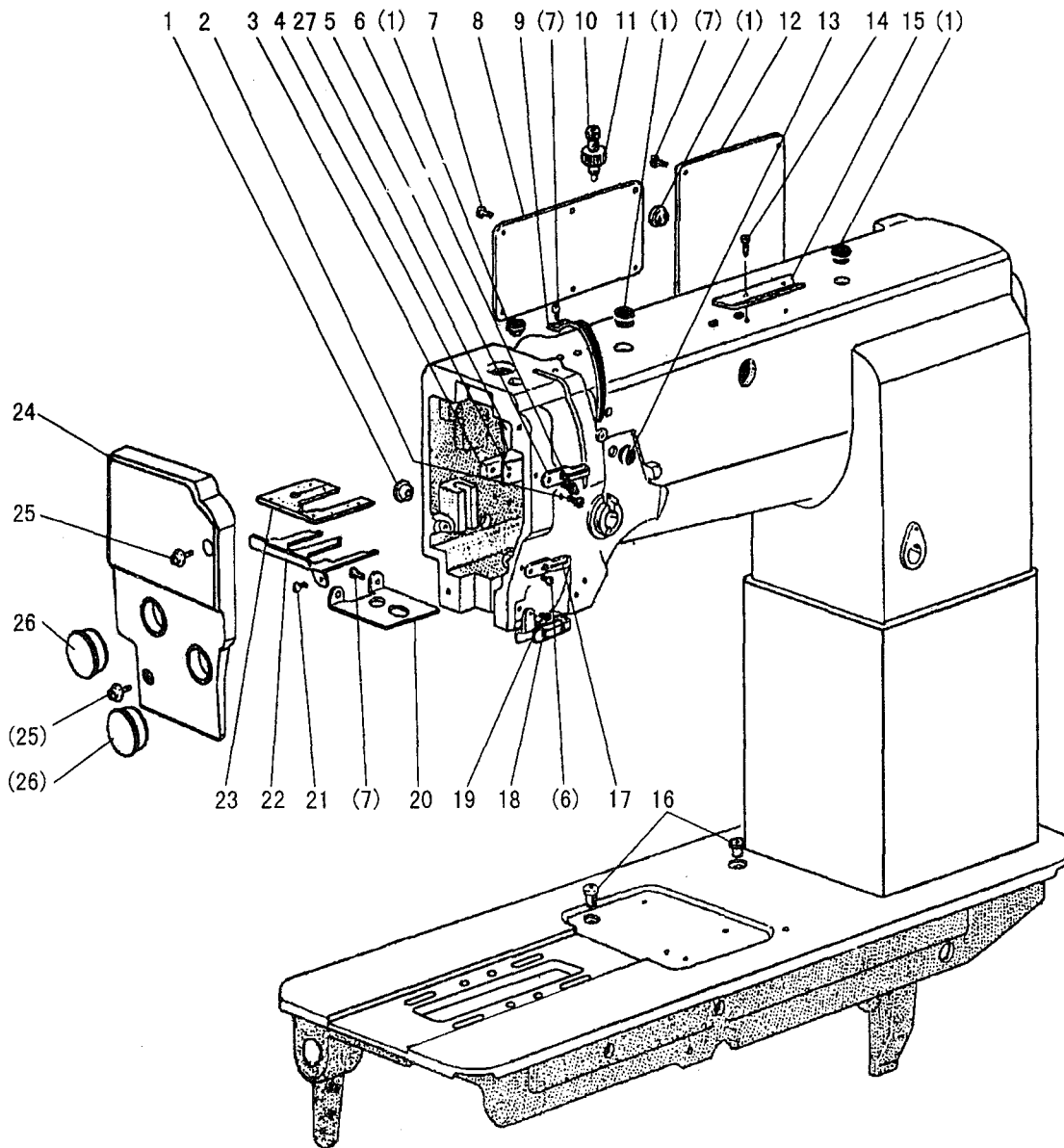

Fig.1

# A. ARM BED AND ITS ACCESSORIES

---



## A.ARM BED AND ITS ACCESSORIES

Fig. No.	Part No.	Description	GC24518-1	GC24518-2	Remarks
A01	H4715B8001	Rubber plug	5	5	φ13
A02	H2400B2080	Screw	2	2	SM3/16(28)×12.1
A03	H2400B2060	Spacer	1	1	
A04	H2400B2050	Oil guard plate	1	1	
A05	H3200B2070	Thread guide	1	1	
A06	H3000D2160	Screw	2	2	SM9/64(40)×4.5
A07	HA300B2170	Screw	13	13	SM11/64(40)×9
A08	H3200B2030	Side cover (left)	1	1	
A09	H3200B2050	Thread take-up cover	1	1	
A10	H3200K0210	Thumb screw	1	1	M10×33
A11	H3200K0220	Special nut	1	1	M10×8.5
A12	H6311B8001	Side cover (right)	1	1	
A13	H2000B2010	Rubber plug	1	1	
A14	HA700B2060	Screw	2	2	SM11/64(40)×8
A15	H2400B2100	Thread guide	1	1	
A16	H2000M0080	Cap	2	2	
A17	H3200B2080	Thread guide (middle)	1	1	
A18	H3212B0066	Thread guide complete(lower)	1	1	
A19	H3200B2100	Screw	1	1	SM9/64(40)×6.5
A20	H3200K0240	Cover	1	1	
A21	H2004J0067	Screw	2	2	SM9/64(40)×7
A22	H3229K0741	Oil guard plate	1	1	
A23	H3229K0742	Felt	1	1	
A24	H3200B2020	Face plate	1	1	
A25	HA300B2160	Screw	2	2	SM11/64(40)×10
A26	HA307B0673	Rubber plug	2	2	
A27	H2400B2050	Oil guard plate	1	1	

# B. THREAD TENSION REGULATOR MECHANISM

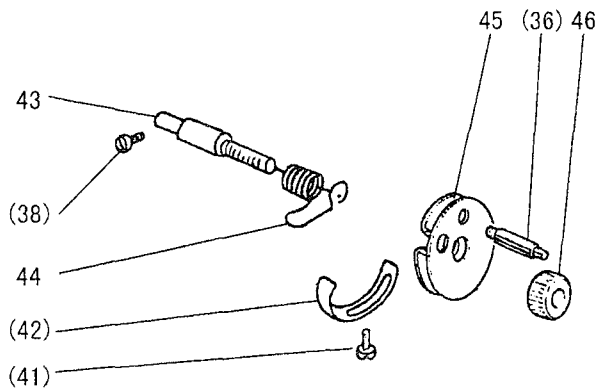
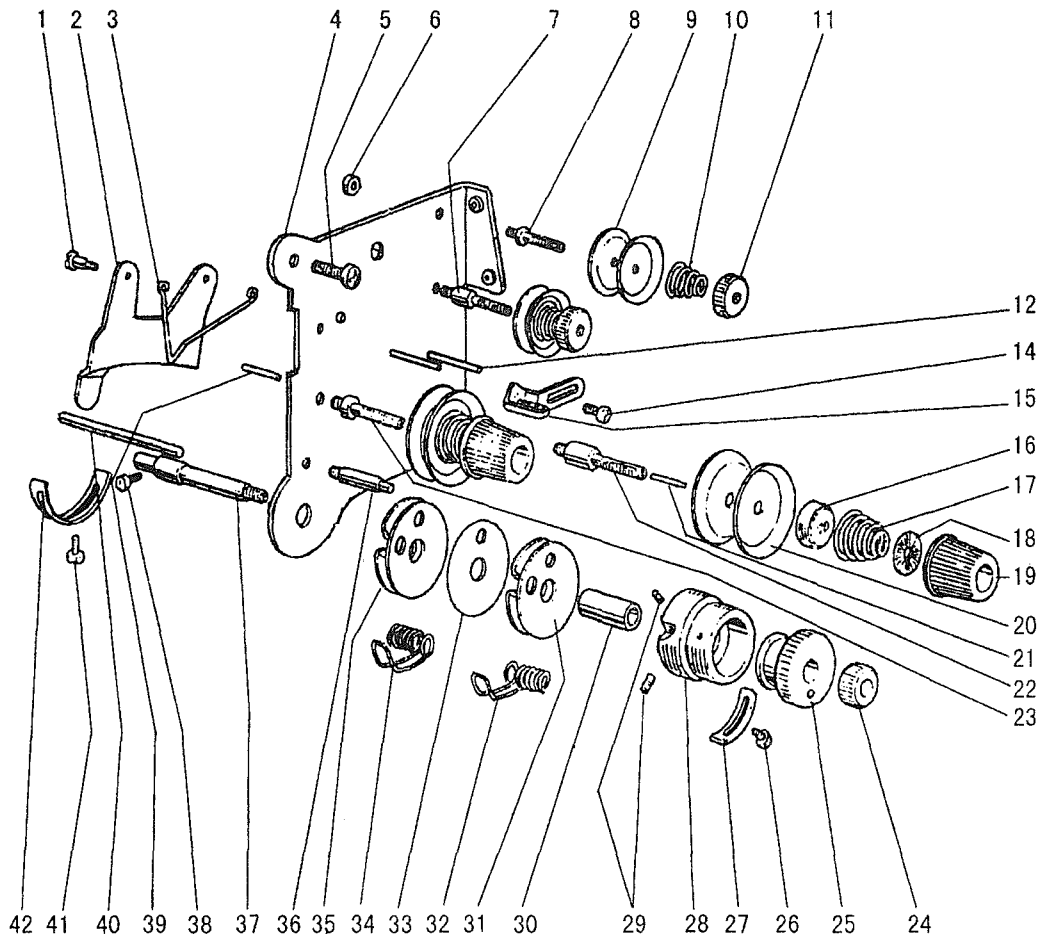

## B.THREAD TENSION REGULATOR MECHANISM

Fig. No.	Part No.	Description	GC24518-1	GC24518-2	Remarks
B01	H3221B6811	Screw	2	2	SM9/64(40)×3
B02	H3221B3142	Tension releasing plate	1	1	
B03	H3221B6812	Tension releasing spring	1	1	
B04	H3221B6820	Mounting plate	1	1	
B05	HA300C2030	Screw	2	2	SM11/64(40)×8
B06	H3221B6810	Nut	2	2	SM11/64(40)×3
B07	H3221B0685	Thread tension stud		1	SM11/64(40)×14
B08	H3221B0683	Thread tension stud	1	1	SM11/64(40)×14
B09	HA112B0693	Thread tension disc	2	4	
B10	H3221B0684	Spring	1	2	
B11	HA710B0671	Thumb nut	1	2	
B12	H3221B0682	Pin	2	3	
B14	HA106B0676	Screw	1	1	SM9/64(40)×6
B15	H3221B0687	Thread guide	1	1	
B16	HA310B0702	Thread tension releasing disc	1	2	
B17	HA607B0068	Spring	1		
B17	HA115B0703	Spring		2	
B18	HA115B7010	Thumb nut revolution stopper	1	2	
B19	HA310B0701	Thumb nut	1	2	
B20	HA310B0705	Thread tension disc	2	4	
B21	H3221B6816	Pin		1	
B22	H3221B0689	Thread tension stud		1	SM1/4(40)×23
B23	H3221B0686	Thread tension stud	1	1	SM1/4(40)×23
B24	H32481B721	Thumb nut		1	SM1/4(40)×4.5
B25	H32481B621	Take-up spring guide		1	
B26	H32481BC21	Screw		1	SM9/64(40)×6
B27	H32481BB21	Stopper		1	
B28	H32481B921	Thread tension post		1	
B29	H32481B521	Screw		2	SM1/8(44)×3.5
B30	H32481B821	Bushing		1	
B31	H32481BF21	Plate complete		1	
B32	H32481B321	Thread Take-up spring		1	
B33	H32481BE21	Plate		1	
B34	H32481B221	Thread Take-up spring		1	
B35	H32481BD21	Plate complete		1	
B36	H32481B421	Screw	1	1	SM9/64(40)×22
B37	H32481B121	Thread tension stud		1	SM1/4(40)×64
B38	H2004J0067	Screw	1	1	SM9/64(40)×7
B39	H3221B6817	Pin	1	1	
B40	H3221B6818	Tension releasing pin	1	1	
B41	H3200B2100	Screw	1	1	SM9/64(40)×6.5
B42	H3221B6819	Stopper	1	1	
B43	H2504C0652	Thread tension stud	1		

## B.THREAD TENSION REGULATOR MECHANISM

Fig. No.	Part No.	Description	GC24518-1	GC24518-2	Remarks
B44	H32481B221	Thread Take-up spring	1		
B45	H32481BD21	Plate complete	1		
B46	H2504C0658	Thumb nut	1		

C. UPPER SHAFT & PRESSER FOOT MECHANISM

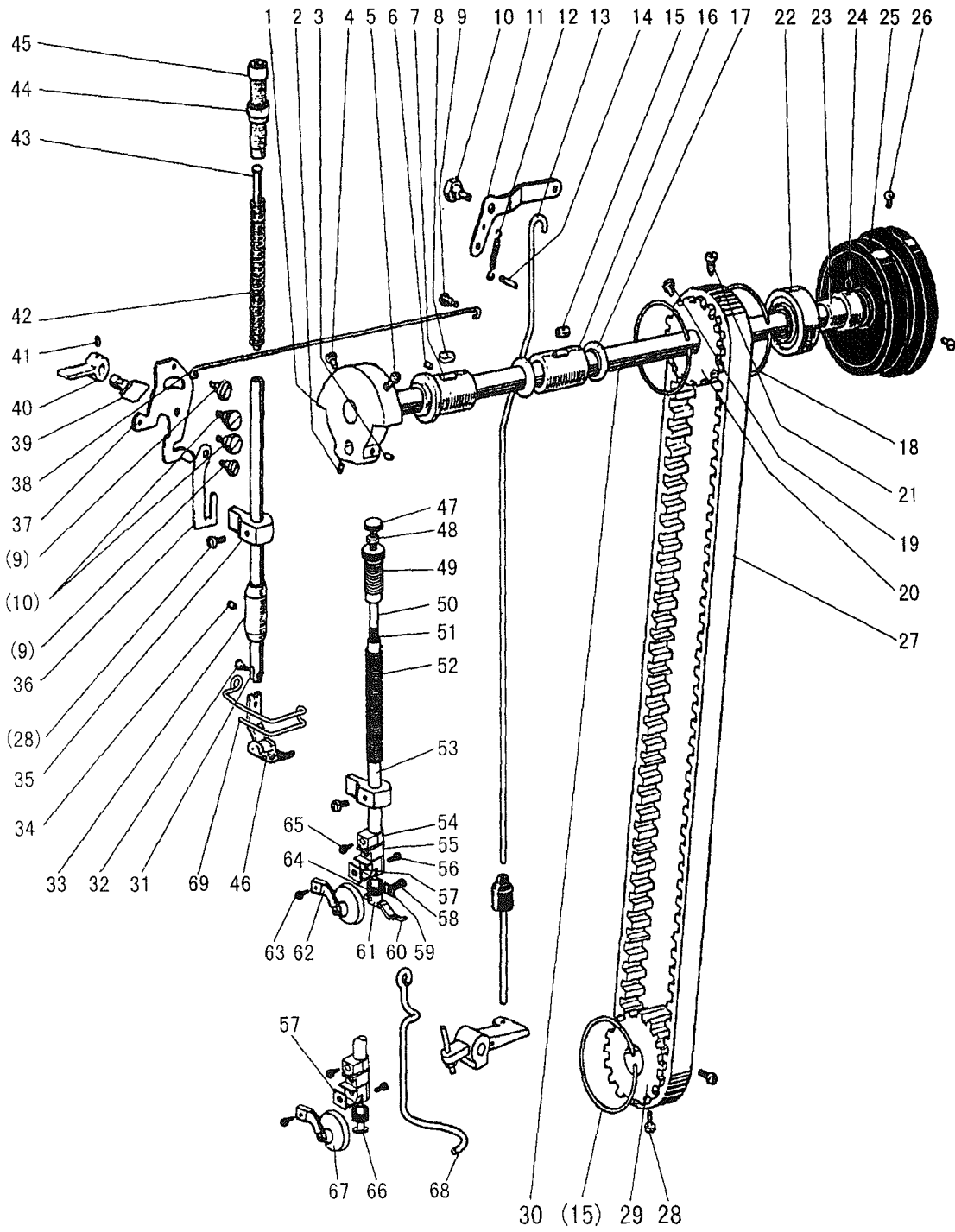

## C. UPPER SHAFT & PRESSER FOOT MECHANISM

Fig. No.	Part No.	Description	GC24518-1	GC24518-2	Remarks
C01	H3204C0021	Needle bar crank complete	1	1	
C02	HA105D0662	Screw	1	1	SM1/4(40)×4
C03	HA307C0662	Screw	1	1	SM1/4(40)×6
C04	HA100C2060	Screw	1	1	SM9/32(28)×13
C05	HA100C2070	Screw	1	1	SM9/32(28)×10
C06	H2405D0664	Screw	1	1	SM15/64(28)×14
C07	H3204B0011	Arm shaft bushing left (complete)	1	1	
C08	H32111B104	Felt	1	1	
C09	HA107H0662	Screw	3	3	SM3/16(28)×2.5
C10	HA100H2050	Bolt	3	3	
C11	H3211E0691	Knee lifter lever (right)	1	1	
C12	H3211E0692	Spring	1	1	
C13	H6307E8001	Knee lifter connecting rod	1	1	
C14	H3200E2090	Pin	1	1	
C15	H32175B304	Felt	1	1	
C16	H32175B104	Arm shaft bushing (middle)	1	1	
C17	HA306D0066	Oil seal	2	2	
C18	H3205C0661	Spring flange	2	2	
C19	HA113F0684	Screw	1	1	SM15/64(28)×8.5
C20	H3205C1021	Pulley	1	1	
C21	HA100F2130	Screw	1	1	SM15/64(28)×6.7
C22	H3205J0662	Ball bearing	1	1	
C23	H3205J0661	Bushing	1	1	
C24	HA113F0684	Screw	2	2	SM15/64(28)×8.5
C25	H4100C2040	Pulley	1	1	
C26	HA110D0672	Screw	2	2	SM15/64(28)×12
C27	H6304C8001	Cog belt	1	1	
C28	HA104F0654	Screw	3	3	SM15/64(28)×10
C29	H3207C0067	Pulley complete	1	1	
C30	H3204C0651	Arm shaft	1	1	
C31	H3200E2010	Presser bar	1	1	
C32	H3200E2020	Screw	1	1	SM1/8(44)×9
C33	HA704B0651	Bushing	1	1	
C34	HA100C2020	Screw	2	2	SM15/64(28)×14
C35	H3207E0661	Presser bar guide bracket	1	1	
C36	H3210E0683	Operation plate	1	1	
C37	H3210E0682	Knee lifter lever left	1	1	
C38	H3210E0681	Knee lifter rod	1	1	
C39	H3200E2060	Presser bar lifting cam	1	1	
C40	H3208E0067	Presser bar lifter (complete)	1	1	
C41	HA100B2110	Screw	2	2	SM11/64(40)×5.5
C42	H3200E2100	Spring	1	1	
C43	HA100H2120	Presser spring guide	1	1	



## C.UPPER SHAFT & PRESSER FOOT MECHANISM

Fig. No.	Part No.	Description	GC24518-1	GC24518-2	Remarks
C44	HA117H0692	Special nut	1	1	
C45	HA309H0681	Thumb nut	1	1	
C46	H6304E7101	Presser foot complete		1	(3/32)
C46	H6204E7101	Presser foot complete	1		
C47	H2400G2150	Screw	1	1	SM11/64(40)×26.5
C48	H2400G2160	Nut	1	1	
C49	H2400G2140	Screw	1	1	SM1/2(28)×26.5
C50	H2400G2170	Pin	1	1	
C51	H2000J2050	Spring	1	1	
C52	H2400G2050	Spring	1	1	
C53	H2404G0651	Presser bar	1	1	
C54	H2404G0653	Stopper	1	1	
C55	H2404G0652	Bracket	1	1	
C56	H2404G0657	Screw	1	1	SM9/64(40)×3.5
C57	H2404G0659	Spacer	1	1	
C58	H2504G0013	Screw		1	SM11/64(32)×7
C59	H2504G0014	Spacer		1	
C60	H6308E8001	Presser foot		1	3/32
C61	H2504G0011	Spring stud		1	
C62	H6310E7101	Roller presser (complete)		1	
C63	H2404G0658	Screw	1	1	SM11/64(32)×7.7
C64	H2404G0655	Spring	1	1	
C65	H2404G0654	Screw	1	1	SM15/64(28)×8
C66	H2404G0656	Spring stud	1		
C67	H2430G0076	Roller presser (complete)	1		
C68	H6314E8001	Finger guard		1	
C68	H6206E8001	Finger guard	1		
C69	H3200E2250	Finger guard	1	1	

# D. THRED TAKE-UP LEVER & NEEDLE BAR MECHANISM

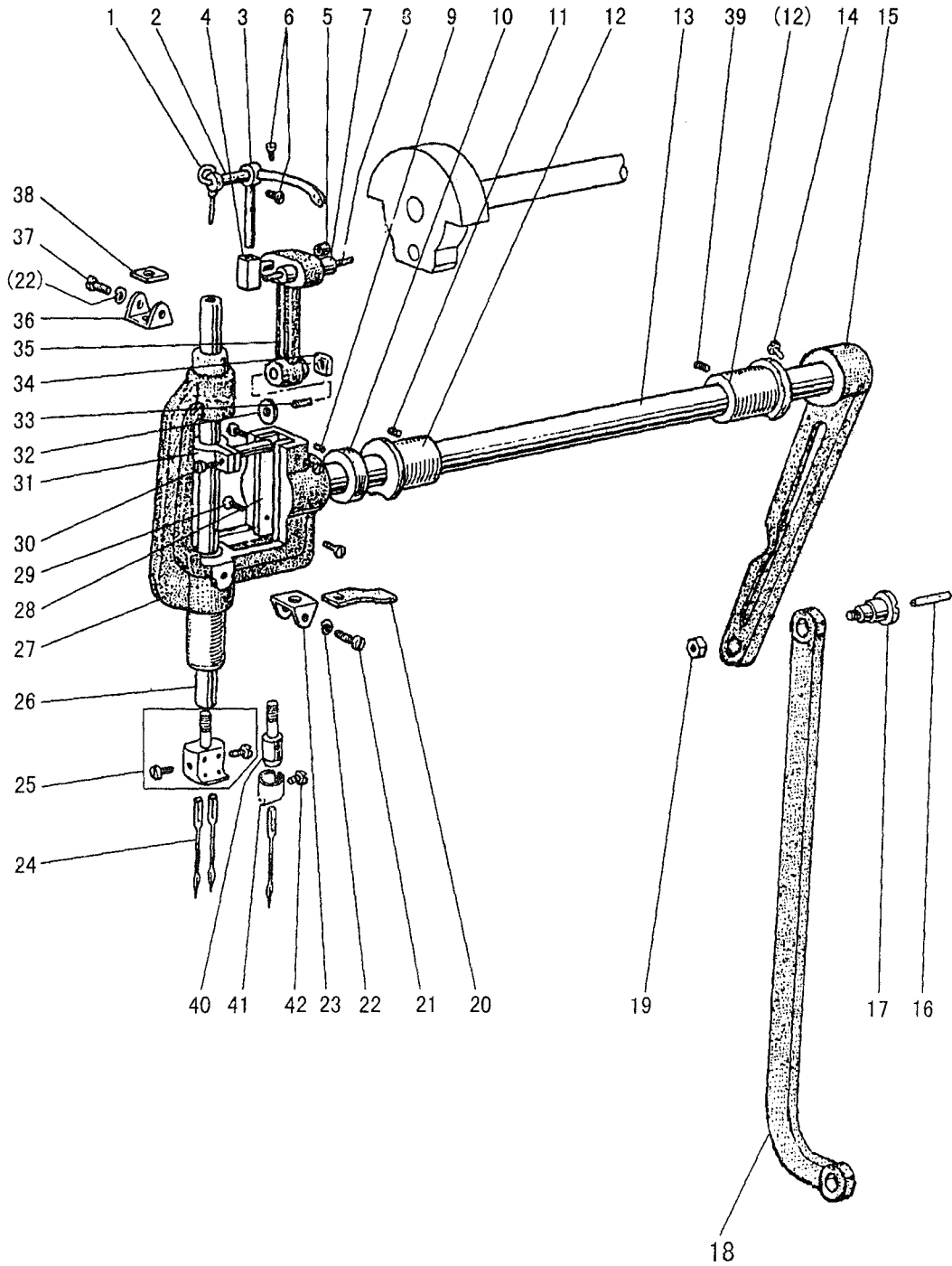

## D.THRED TAKE-UP LEVER & NEEDLE BAR MECHANISM

Fig. No.	Part No.	Description	GC24518-1	GC24518-2	Remarks
D01	H2405D1122	Oil wick	1	1	2.5×240
D02	H32422C108	Thread Take-up guide bracket pin	1	1	
D03	H3504B0651	Thread Take-up lever		1	
D03	H2405D1111	Thread Take-up lever	1		
D04	H2405D1112	Thread Take-up slide block	1	1	
D05	H24211D305	Plug	1	1	
D06	HA110D0672	Screw	3	3	SM15/64(28)×12
D07	H2405D0662	Thread take-up crank pin	1	1	
D08	H2405D0662	Oil wick	1	1	
D09	HA307C0662	Screw	1	1	SM1/4(40)×6
D10	H3205D0066	Coller (complete)	1	1	
D11	HA3411D308	Screw	1	1	SM15/64(28)×7
D12	H3204B0652	Needle bar rock shaft bushing	2	2	
D13	H3204D0652	Needle bar rock shaft	1	1	
D14	H2012N0652	Screw	1	1	SM1/4(24)×15
D15	H6306D8001	Needle bar rock shaf crank	1	1	
D16	H32311D406	Oil wick	1	1	
D17	H32311D306	Screw	1	1	SM5/16(24)×26.2
D18	H6304D8001	Link	1	1	
D19	H32311D506	Nut	1	1	SM5/16(24)×5.5
D20	H3204D0656	Felt	1	1	
D21	H3204D6510	Screw	2	2	SM1/8(44)×4.8
D22	H005008030	Spring washer	4	4	GB/T93 3
D23	H3204D0657	Holder	1	1	
D24	H2404D0653	Needle	1	2	DP×5 #16
D25	H3200D2040	Needle clamp complete		1	
D26	H32111D404	Needle bar	1	1	
D27	H32111D104	Needle bar rock frame	1	1	
D28	H32111D204	Spacer	2	2	
D29	H32111D304	Screw	4	4	SM3/32(56)×4
D30	H32111D604	Screw	1	1	SM9/64(40)×8.5
D31	H32111D504	Needle bar connecting	1	1	
D32	H3204D6512	Washer	1	1	
D33	H3204D6513	Felt	1	1	
D34	H32111D804	Square block	1	1	
D35	H32111D704	Needle bar connecting link	1	1	
D36	H3204D0655	Holder	1	1	
D37	H3204D6511	Screw	2	2	SM1/8(44)×3.5
D38	H3204D0654	Felt	1	1	
D39	HA100C2020	Screw	1	1	SM15/64(28)×14
D40	H6204D8001	Needle clamp	1		
D41	HA500C2030	Needle bar thread guide	1		
D42	HA100C2170	Screw	1		SM1/8(44)×4.5

# E. STITCH REGULATOR MECHANISM

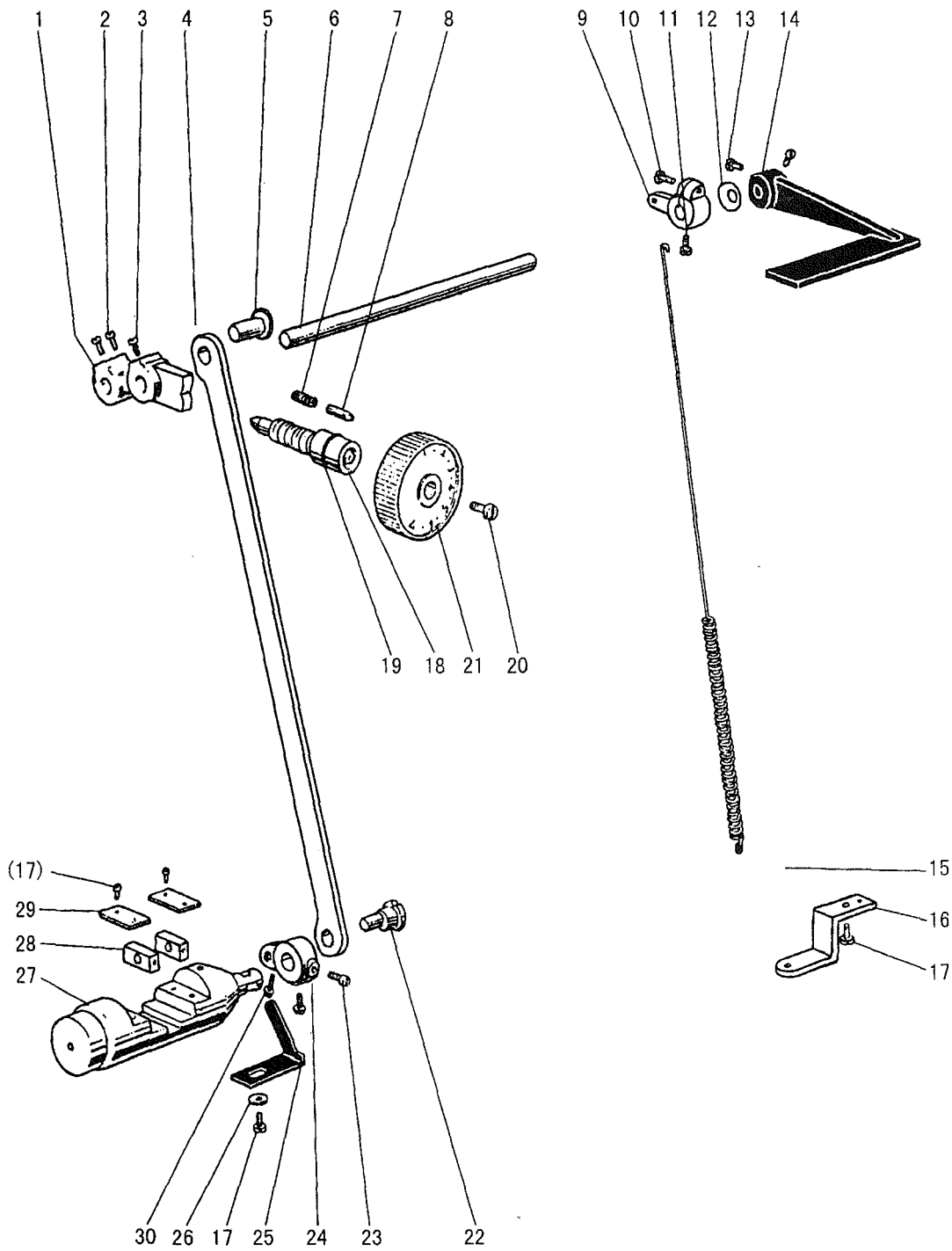

## E.STITCH REGULATOR MECHANISM

Fig. No.	Part No.	Description	GC24518-1	GC24518-2	Remarks
E01	H6309F8001	Feed regulator	1	1	
E02	HA113F0684	Screw	2	2	SM15/64(28)×8.5
E03	H3200F2020	Screw	1	1	SM15/64(28)×12
E04	H6304F8001	Connecting link	1	1	
E05	HA100G2070	Hinge pin	1	1	
E06	H3200F2060	Reverse stitch shaft	1	1	
E07	H3200F2110	Spring	1	1	
E08	HA100F2080	Pin	1	1	φ4×16
E09	H6306F8001	Reverse stitch shaft crank	1	1	
E10	HA800F2020	Screw	1	1	SM15/64(28)×12
E11	H3207F0672	Screw	1	1	SM11/64(40)×8.5
E12	HA100F2110	Spring washer	1	1	
E13	HA113F0684	Screw	2	2	SM15/64(28)×8.5
E14	H3216F0071	Reverse sewing lever(complete)	1	1	
E15	H6307F8001	Spring	1	1	
E16	H6308F8001	Bracket for spring	1	1	
E17	HA300C2030	Screw	6	6	SM11/64(40)×8
E18	HA109F0671	Screw bar	1	1	
E19	HA109F0674	O-ring	1	1	
E20	HA109F0673	Screw	1	1	SM3/16(28)×6
E21	H3404F0651	Dial	1	1	
E22	H3206F0662	Eccentric shaft	1	1	
E23	H3210F0681	Screw	2	2	SM15/64(28)×10
E24	H3210F0683	Stitch regulating crank lower	1	1	
E25	H3200F2080	Holding plate of reverse bar	1	1	
E26	HA703R0067	Washer	1	1	
E27	H3212F0692	Reverse bar	1	1	
E28	H3208G0672	Square block	2	2	
E29	H3212F0691	Guide plate	2	2	
E30	H3210F0682	Screw	1	1	M5×14

# F. LOWER SHAFT & FEED ROCK SHAFT MECHANISM

---

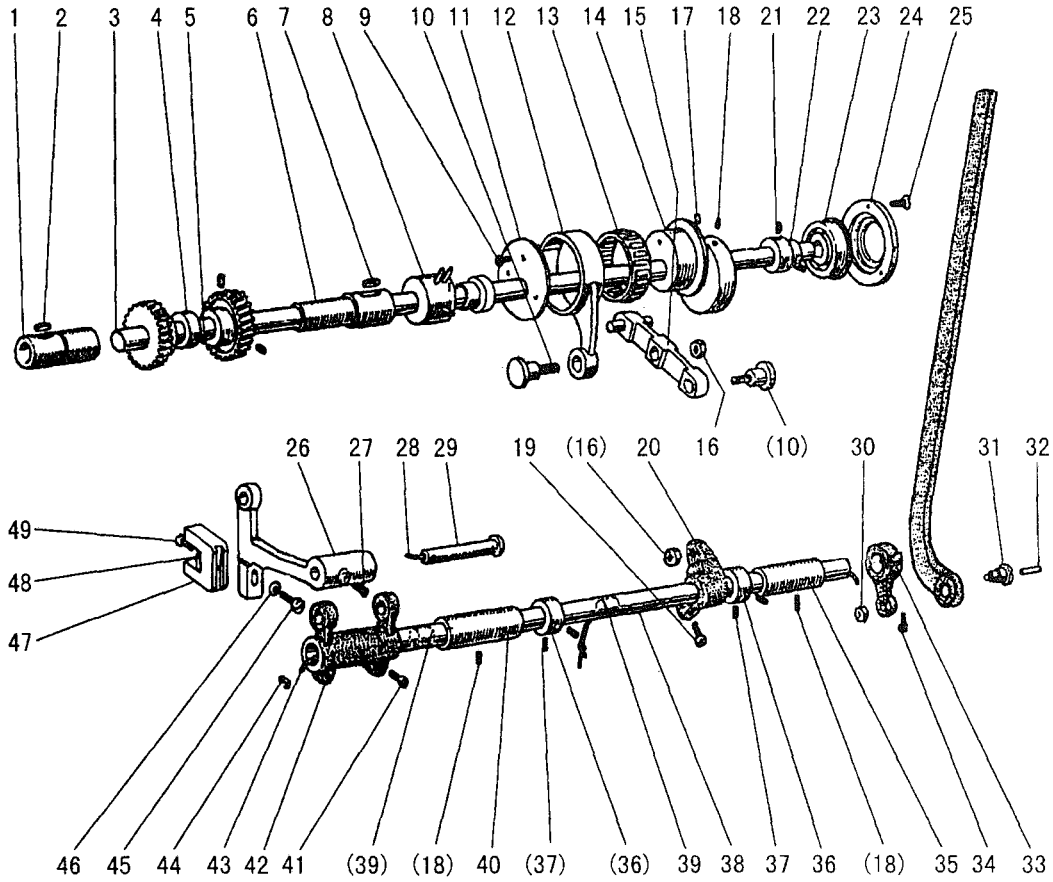

## F.LOWER SHAFT & FEED ROCK SHAFT MECHANISM

Fig. No.	Part No.	Description	GC24518-1	GC24518-2	Remarks
F01	H6314B7101	Lower shaft bushing left	1	1	
F02	H32132B204	Oil wick	1	1	
F03	H6304H8001	Lower shaft	1	1	
F04	H3205H0655	Feed lifting cam	1	1	
F05	H3205H0654	Screw	1	1	SM1/4(40)×5
F06	H6316B7101	Lower shaft bushing right (complete)	1	1	
F07	H32132B204	Oil wick	1	1	
F08	H3204B0054	Lower shaft bushing middle (complete)	1	1	
F09	HA700F2100	Screw	3	3	SM11/64(40)×7
F10	H3208G0674	Screw	2	2	SM1/4(24)×22
F11	H32372G208	Washer	1	1	
F12	H32372G408	Feed Connecting rod	1	1	
F13	H32372G308	Needle bearing	1	1	
F14	H32372G108	Level feed connecting cam	1	1	
F15	H3208G2011	Link (complete)	1	1	
F16	H3208G0675	Nut	2	2	SM1/4(24)×3.5
F17	HA100C2020	Screw	1	1	SM15/64(28)×14
F18	H2405D0664	Screw	3	3	SM15/64(28)×14
F19	H3208G0676	Screw	1	1	SM15/64(28)×14
F20	H3208G0673	Connecting rod crank(middle)	1	1	
F21	HA105D0662	Screw	2	2	SM1/4(40)×4
F22	H3208H0662	Bushing	1	1	
F23	H3208H0661	Ball bearing	1	1	
F24	H3200H2060	Bearing holder	1	1	
F25	HA7311C306	Screw	3	3	SM9/64(40)×7
F26	H6305G8001	Feed bar	1	1	
F27	H431050050	Screw	1	1	GB/T80 M5×5
F28	H3205G0662	Oil wick	1	1	
F29	H32243G205	Feed bar shaft	1	1	
F30	H3206D0674	Nut	1	1	SM5/16(24)×5
F31	H32311D306	Screw	1	1	SM5/16(24)×26.2
F32	H32311D406	Oil wick	1	1	
F33	H6305D8001	Feed rock shaft crank(right)	1	1	
F34	H2012N0652	Screw	1	1	SM1/4(24)×15
F35	H3204B0656	Feed rock shaft bushing(right)	1	1	
F36	HA108G0066	Coller (complete)	2	2	
F37	HA105D0662	Screw	4	4	SM1/4(40)×4
F38	H3204G0651	Feed rock shaft	1	1	
F39	H3204G0652	Felt	2	2	
F40	HA100G2120	Feed rock shaft bushing(left)	1	1	
F41	HA104G1012	Screw	2	2	SM3/16(28)×12
F42	H3205G1032	Feed bar assy crank	1	1	
F43	H3204G0031	Oil wick	1	1	

## F.LOWER SHAFT & FEED ROCK SHAFT MECHANISM

Fig. No.	Part No.	Description	GC24518-1	GC24518-2	Remarks
F44	H3200G2030	Holder	1	1	
F45	H3200H2040	Bolt	1	1	SM15/64(28)×18
F46	H005001060	Washer	1	1	GB/T97.1 6
F47	H3205H0651	Feed bar connecting fork	1	1	
F48	H3205H0652	Felt	1	1	
F49	H3205H0653	Screw	1	1	SM1/8(44)×4



# G. HOOK SADDLE MECHANISM

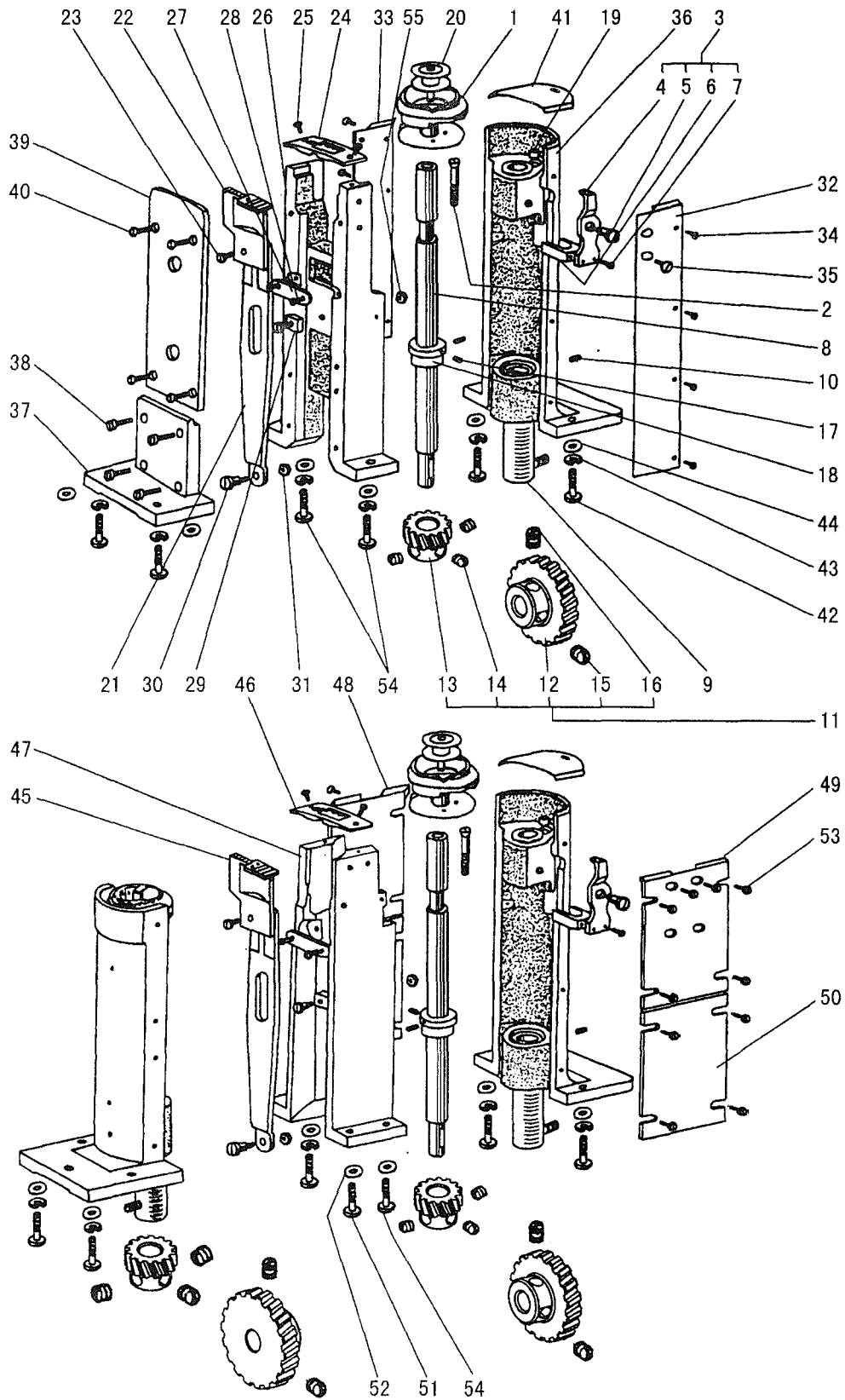

## G.HOOK SADDLE MECHANISM

Fig. No.	Part No.	Description	GC24518-1	GC24518-2	Remarks
G01	H2404I0651	Hook complete	1	2	
G02	H2404I0652	Screw	1	2	SM9/64(40)×13
G03	H2404I0653	Opener(comeplete)	1	2	
G04	H2404I0031	Opener	1	2	
G05	H2404I0032	Screw	1	2	SM9/32(28)×4
G06	H2404I0033	Opener bracket	1	2	
G07	H2404I0034	Screw	1	2	SM9/64(40)×8.5
G08	H6305I8001	Hook shaft	1	2	
G09	H6306I7101	Hook shaft bushing	1	2	
G10	HA100B2110	Screw	1	2	SM11/64(40)×5.5
G11	H6308I7101	Gear(comeplete)	1	2	
G12	H32142I104	Gear(large)	1	2	
G13	H32142I204	Gear(small)	1	2	
G14	HA105D0662	Screw	3	6	SM1/4(40)×4
G15	H3204I6510	Screw	1	2	SM1/4(40)×6.5
G16	HA307C0662	Screw	1	2	SM1/4(40)×6
G17	HA105D0662	Screw	2	4	SM1/4(40)×4
G18	H2404I0081	Coller	1	2	
G19	H2404I0659	Felt	1	2	
G20	H2400I2020	Bobbin	1	2	
G21	H2406I0661	Feed plate	1	1	
G22	H6204I8001	Feed dog	1		3/32
G23	HA300B2130	Screw	1	1	SM11/64(40)×5.5
G24	H6205I8001	Needle plate	1		
G25	H2406I0664	Screw	2	2	SM9/64(40)×7.5
G26	H2406I0665	Feed plate set bracket	1		
G27	H2406I0666	Supporter plate	1	1	
G28	HA300B2190	Screw	2	2	SM11/64(40)×6.5
G29	H2406I0667	Square block(comeplete)	1	1	
G30	H6311I8001	Screw	1	1	SM11/64(40)×6.5
G31	H2000M0120	Nut	1	1	
G32	H2400I2050	Cover plate	1		
G33	H2400I2060	Cover plate	1		
G34	H2400I2070	Screw	8		SM9/64(40)×4
G35	H2400I2080	Screw	3	4	SM11/64(40)×3
G36	H2404I0654	Hook shaft supporter	1	2	
G37	H2400I2090	Side cover bracket	1		
G38	HA111G0683	Screw	1		SM11/64(40)×12
G39	H2400I2100	Rear cover plate	1		
G40	HA100C2190	Screw	1		SM11/64(40)×8
G41	H2400I2110	Slide plate	1	2	
G42	H2400I2120	Screw	4	4	SM9/64(40)×2
G43	H005008080	Spring washer	4	6	GB/T93 8

# G.HOOK SADDLE MECHANISM

Fig. No.	Part No.	Description	GC24518-1	GC24518-2	Remarks
G44	H005004080	Washer	6	6	GB/T848 8
G45	H6310I8001	Feed dog		1	3/32
G46	H6309I8001	Needle plate		1	3/32
G47	H2504I0653	Feed plate set bracket		1	
G48	H2500I2030	Cover plate		1	
G49	H2500I2020	Cover plate		1	
G50	H2500I2040	Cover plate		2	
G51	H2500I2050	Screw		2	SM1/4(24)×16.5
G52	H005004080	Washer		2	GB/T848 8
G53	HA7311C606	Screw		16	SM11/64(40)×15
G54	H6312I8001	Screw	2	2	SM5/16(24)×18.5
G55	H2000I2160	Nut	1	1	

# H. OIL LUBRICATION MECHANISM

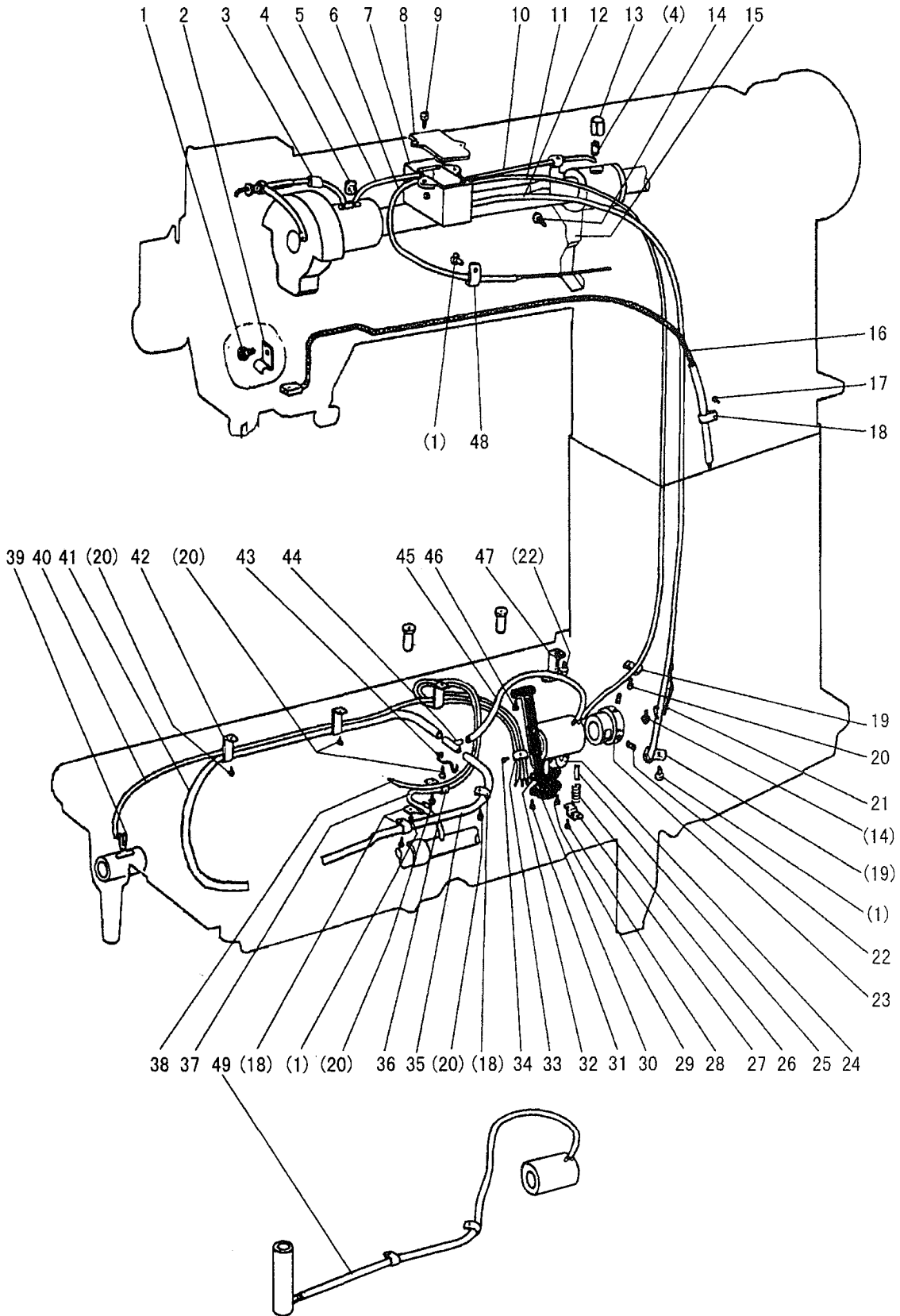

## H.OIL LUBRICATION MECHANISM

Fig. No.	Part No.	Description	GC24518-1	GC24518-2	Remarks
H01	HA300C2030	Screw	4	4	SM11/64(40)×8
H02	H3200K0050	Holder	1	1	
H03	H32422C208	Pipe	1	1	
H04	H32175B304	Felt	2	2	
H05	H3204K0032	Oil pipe & wick complete	1	1	
H06	H3204K0043	Oil pipe & wick complete	1	1	
H07	H3204K0011	Oil tank complete	1	1	
H08	H3204K0659	Gasket	1	1	
H09	H411040160	Screw	2	2	GB/T819.1 M4×16
H10	H3204K0074	Oil pipe & wick complete	1	1	
H11	H6304K8001	Pipe	1	1	
H12	H6305K8001	Pipe	1	1	
H13	H3200K0230	Pipe	1	1	
H14	HA300B2170	Screw	3	3	SM11/64(40)×9
H15	H3200K0040	Holder	1	1	
H16	H3209K0066	pipe & felt complete	1	1	
H17	HA7311CC06	Screw	7	7	SM9/64(40)×6.5
H18	H32311D606	Holder	3	3	
H19	H3200K0190	Holder	2	2	
H20	HA300B2130	Screw	6	7	SM11/64(40)×5.5
H21	H3200K0200	Holder	1	1	
H22	H3230K0751	Screw	2	2	SM11/64(40)×10
H23	H3230K0752	Bushing	1	1	
H24	H3215K0696	Pipe	1	1	
H25	H1100I2070	Pin	1	1	
H26	H1100I2090	Spring	1	1	
H27	H1100I2110	Spring holder	1	1	
H28	H3204D6510	Screw	1	1	SM1/8(44)×4.8
H29	H3215K0693	Screw	1	1	SM9/64(40)×5
H30	H3215K0692	Filter	1	1	
H31	H3215K0694	Screw	1	1	SM9/64(40)×7
H32	H3215K4011	Base plate complete	1	1	
H33	H3215K0695	Holder	1	1	
H34	HA106B0676	Screw	1	1	SM9/64(40)×6
H35	H3210K0672	Pipe	1	1	
H36	H3200K0170	Holder	1	1	
H37	H3218K0072	Oil pipe & wick complete	1	1	
H38	H3217K0071	Oil pipe & wick complete	1	1	
H39	H3200K0180	Oil wick	3	3	
H40	H3216K0070	Oil pipe & wick complete	1	1	
H41	H3204K0655	Pipe		1	
H42	H3200K0160	Holder	3	3	
H43	H3210K0674	Holder		1	

## H.OIL LUBRICATION MECHANISM

Fig. No.	Part No.	Description	GC24518-1	GC24518-2	Remarks
H44	H3210K0671	Oil pipe connector		1	SM11/64(40)×10
H45	H3210K0673	Pipe		1	
H46	HA100E2150	Screw	2	2	
H47	H3200K0250	Holding plate	1	1	
H48	H3200K0030	Holder	1	1	
H49	H6204K8001	Pipe	1		

# I. ACCESSORIES

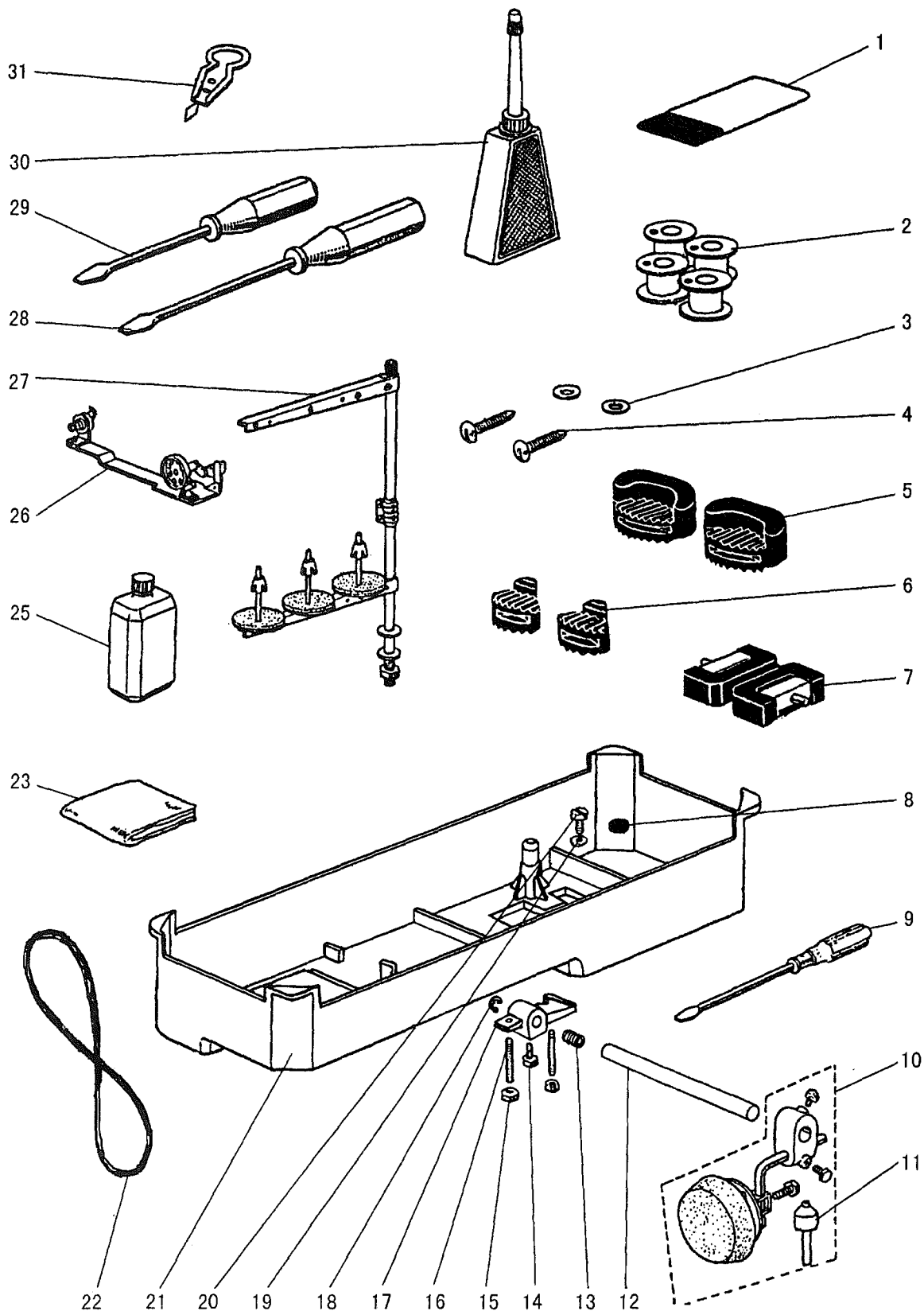

I. ACCESSORIES

---

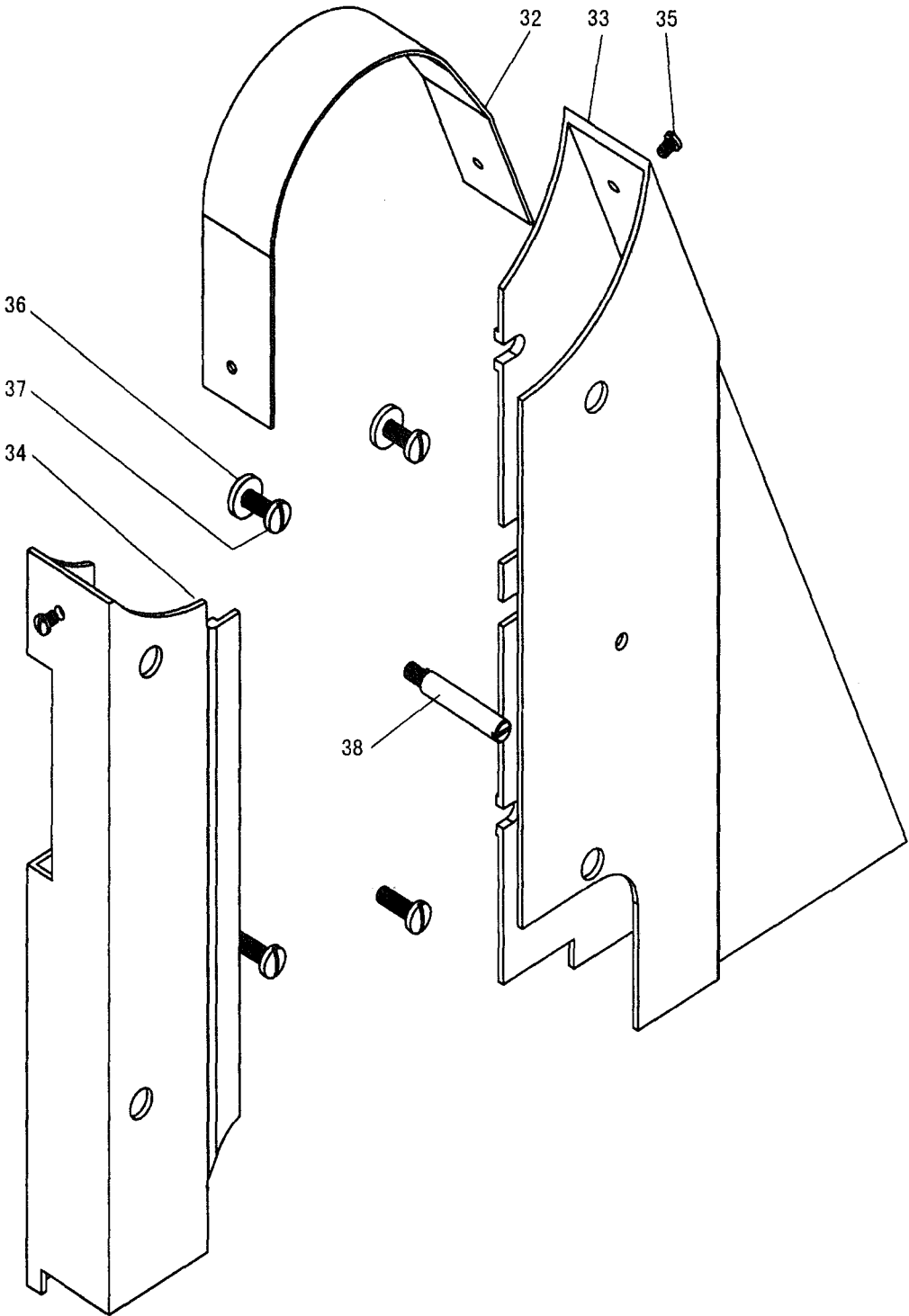



# I.ACCESSORIES

Fig. No.	Part No.	Description	GC24518-1	GC24518-2	Remarks
I01	H2404D0653	Needle		6	
I02	H2400I2020	Bobbin	2	4	
I03	H3200L0050	Washer	4	4	
I04	H801045200	Screw	4	4	GB/T99 4.5×20
I05	H3200L0020	Vibration preventing rubber	2	2	
I06	H3200L0030	Vibration preventing rubber	2	2	
I07	HA307J0067	Hinge complete	2	2	
I08	HA100J2120	Magnet block for reservoir	1	1	
I09	HA300J2070	Screw driver(large)	1	1	
I10	H3214L0067	Small parts	1	1	
I11	H3214L2011	Knee lifter pin	1	1	
I12	H3213L0662	Knee lifter shaft	1	1	
I13	HA104J0657	Spring	1	1	
I14	HA106J0664	Bolt	1	1	
I15	HA104J6510	Nut	2	2	
I16	HA104J0659	Screw	2	2	SM15/64"(28)×27
I17	H3213L0664	Knee lifter crank	1	1	
I18	H007013090	E-type stop ring	1	1	GB/T896 9
I19	HA104J0653	Washer	1	1	
I20	HA104J0652	Screw	1	1	SM5/16"(28)×12
I21	H3213L0661	Oil reservoir	1	1	
I22	H2400K0080	V-belt	1	1	M55
I23	HA100J2180	Vinyl cover	1	1	
I25	H3200L0130	Oil can	1	1	
I26	HA706S0067	Bobbin windér	1	1	
I26	HA200J2030	Cotton stand	1		
I27	H3200L0120	Cotton stand		1	
I28	HA300J2200	Screw driver(middle)	1	1	
I29	HA300J2210	Screw driver(small)	1	1	
I30	HA100J2110	Oiler	1	1	
I31	H3207L0065	Thread needle kit	1	1	
I32	H6307L8001	Belt cover (upper)	1	1	
I33	H6309L8001	Belt cover (right)	1	1	
I34	H6310L8001	Belt cover (left)	1	1	
I35	H2000O0360	Screw	2	2	SM11/64" (40) ×6.2
I36	H6722N8001	Washer	2	2	
I37	H0207L8001	Screw	4	4	SM15/64" (28) ×18
I38	H0208L8001	Screw	1	1	SM15/64" (28) ×10

OTHER REPLACEMENT PARTS:

Description Width	Feed Dog	Needle Plate	Spacer	Needle Clamp	Presser Foot	Quantity
2.0mm(5/64")	H6319I8001	H6320I8001	H2404G0659	H2504D0021	H6308E8001	1
2.4mm(3/32")	H6319I8001	H6320I8001	H2404G0659	H2504D0021	H6308E8001	1
3.2mm(1/8")	H6318I8001	H6317I8001	H2504G0041	H3200D2200	H6313E8001	1



**SHANGHAI HUIGONG NO.3 SEWING MACHINE FACTORY**

**ADD: 1418, Yishan Road, Shanghai, China**

**Zip Code: 201103**

**Overseas Business: TEL: 86-21-64853303 FAX: 86-21-64854304**

**E-mail: [highlead@online.sh.cn](mailto:highlead@online.sh.cn) <http://www.highlead.com.cn>**

The description covered in this manual is subject to change for improvement of the commodity without notice

2004.2. Printed