

HIGHLEAD

GC20688-DC/GC20688-BDC

**Compound-Feed, Heavy Material Lockstitch Sewing
Machine With Edge Cutter**

**Instruction Manual
Parts Catalog**

SHANGHAI HUIGONG NO.3 SEWING MACHINE FACTORY

From the library of: Superior Sewing Machine & Supply LLC

----- CONTENTS -----

1. PRECAUTIONS BEFORE STARTING OPERATION	1
1) Safety precautions.....	1
2) Precaution before Starting Operation.....	1
3) Precaution for Operating Conditions.....	1
2. SPECIFICATIONS	1
3. PREPARATION BEFORE STARTING TO OPERATE	2
1) Connection of control box	2
2) Oil pan.....	3
3) Operation panel.....	3
4) Adjusting the needle stop position.....	3
5) Lubrication	4
4. HOW TO USE THE MACHINE	4
1) Threading.....	4
2) Adjusting of the thread regulator.....	5
3) Adjusting of upper thread tension.....	5
4) Winding the lower thread.....	5
5) Threading the lower thread.....	5
6) Adjusting the lower-thread tension	6
7) Installing the needle	6
8) Alternating presser foot movement amount	6
9) Adjusting the presser foot pressure	6
10) Adjusting the stitch length	6
11) Using the manual switches	7
12) Cleaning	7
13) Lubrication	7
14) Adjusting the trailing length after thread trimming.....	8
15) Back tacking	8
16) Adjusting the feed dog.....	9
17) Adjusting the needle bar height.....	9
18) Adjusting the gap between the needle and the rotary hook tip.....	10
19) Adjusting of the needle and the hook timing	10
20) Hook protection.....	10
21) Adjusting the needle and feed mechanism timing.....	11
22) Adjusting the opener position	12
23) Adjusting the presser foot height.....	12
24) Adjusting the alternating presser foot movement amount	13

25) Adjusting the presser foot timing	14
26) Adjusting the fixed knife position.....	15
27) Adjusting the thread holding spring position	15
28) Adjusting the knife timing position	15
29) Adjusting the driving knife height.....	15
30) Adjusting the driving knife stop position.....	16
31) Adjusting the driving knife operating position	16
32) Adjusting the thread trimming timing.....	17
33) Safety clutch	17
34) Regulate the atmospheric pressure	18
5. HOW TO USE THE VERTICAL CUTTER	18
1) Idle of the knife when the vertical cutter is turned off.....	19
2) Timing of the deactivation of the knife	19
3) Position of the release block	19
4) Lubrication of the eccentric	19
5) Stroke of the knife	19
6) Timing of knife movement	20
7) Knife overlap	20
8) Setting and pressure of the knife blades	20

----- PARTS LIST -----

A. ARM BED AND ITS ACCESSORIES.....	21
B. THREAD TENSION REGULATOR MECHANISM	25
C. SEWING MECHANISM.....	28
D. PRESSER FOOT MECHANISM	31
E. UPPER FEED LIFTING ROCK SHAFT MECHANISM.....	34
F. STITCH REGULATOR MECHANISM.....	37
G. FEEDING AND FEED LIFTING & ROTATING HOOK SHAFT MECHANISM	40
H. HOOK SADDLE MECHANISM (RIGHT).....	43
I. OIL LUBRICATION MECHANISM	47
J. ACCESSORIES.....	50
K. PNEUMATIC CONTROL MECHANISM.....	52
L. KNIFE MECHANISM	54

1. PRECAUTIONS BEFORE STARTING OPERATION

1) Safety precautions

- (1) When turning the power on, keep your hands and fingers away from the area around/under the needle and the area around the pulley.
- (2) Power must be turned off when the machine is not used, or when the operator leaves his/her seat.
- (3) The power must be turned off before tilting the machine head, installing or adjusting the machine, or when replacing.
- (4) Avoid placing fingers, hairs, bars etc. nears the pulley, bobbin winder pulley, when the machine is operation. Injury could result.
- (5) Do not insert fingers into the thread take-up cover, under/round the needle, or pulley when the machine is in operation.
- (6) If a mini motor cover, finger guard, and/or eye guard are installed, do not operate the machine without these safety devices.

2) Precaution before starting operation

- (1) If the machine's oil pan has an oil sump, never operate the machine before filling it.
- (2) If the machine is lubricated by a drop oiler, never operate the machine before lubricating.
- (3) When a new sewing machine is first turned on, verify the rotational direction of the pulley with the power on. (The pulley should rotate counterclockwise when viewed from the pulley.)
- (4) Verify the voltage and (single or three) phase with those given on the machine nameplate.

3) Precaution for Operating Conditions

- (1) Avoid using the machine at abnormally high temperature (35°C or higher) or low temperatures (5°C or lower). Otherwise, machine failure may result.
- (2) Avoid using the machine in dusty conditions. Avoid using the machine in areas where too much electrical noise, resulted from the high-frequency welder and others, is generated

2. SPECIFICATIONS

Item		GC20688-DC	GC20688-BDC
Max. Speed		3000rpm	2800rpm
Stitch length		0 to 6mm	0 to 6mm
Needle bar stroke		34mm	34mm
Presser foot clearance	By hand	9 mm	9 mm
	By knee	16 mm	16 mm
Rotating hook		1.6 times	2.5 times
Needle		DP×17 #18-#25	DP×17 #18-#25
Presser foot alternation		1-7mm	1-7mm
Auto presser foot lifter		Pneumatic	Pneumatic
Oil lubrication method		Automatic lubrication	Automatic lubrication
Bed dimensions		300×120 mm	300×120 mm
Needle gauge (mm)		3	8

If sewing with stitch length of 6 mm or more, set the sewing speed to 2000 rpm or less.

3. PREPARATION BEFORE STARTING TO OPERATE

1) Connection of control box

It shows the connection of the electrical wires of the whole machine on the right picture.

When the machine needs to be assembled, each line should be linked to the right joint according to the instruction of the picture.

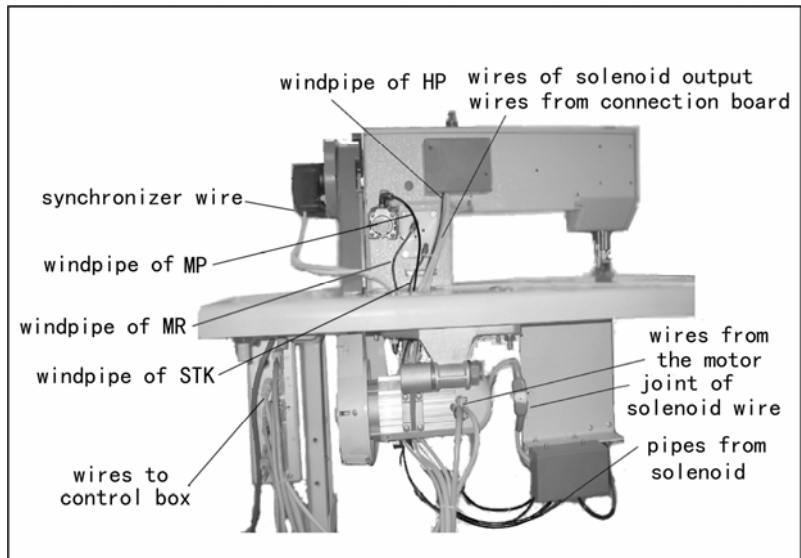

All the pins on the control box have signals of function showing, and usually, different wires have different kinds of joint.

Caution: the pin of synchronizer wire is the same with another two external pins and if there is a misconnection, the synchronizer might be burn.

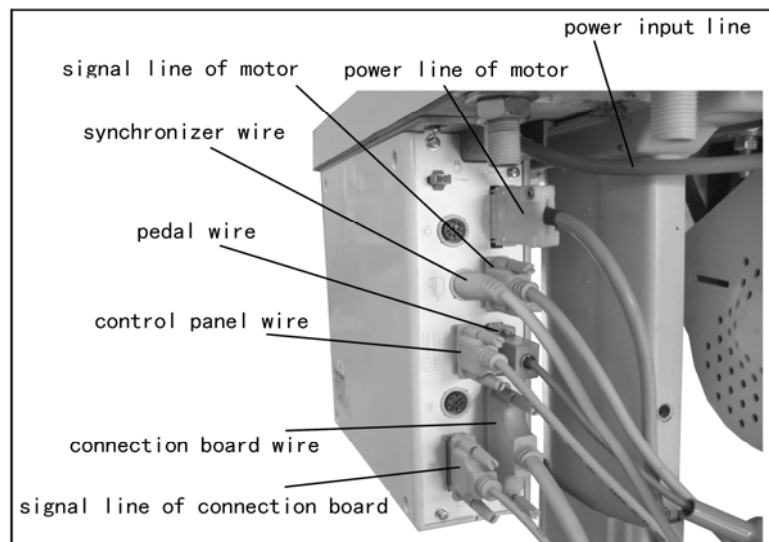

When connecting the pipes, please check the joint at the picture of the whole machine above as reference.

And also there have an instruction mark of each joint of the solenoid at the setting board.

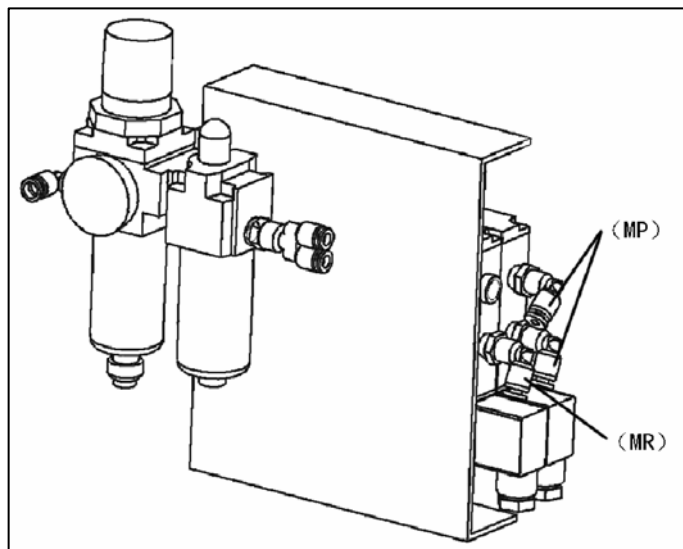

2) Oil pan

(1) Install the oil pan 3 to the underside of the worktable 1 in the place shown in the illustration using the nails 2.

(2) From front view, the oil pan 3 to the side is 60mm; from right view, the oil pan 3 to the side is 80mm.

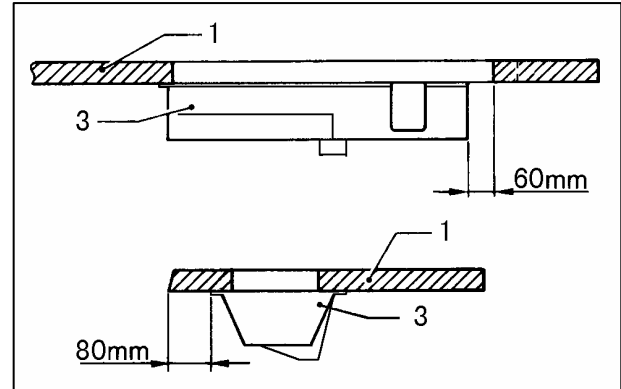
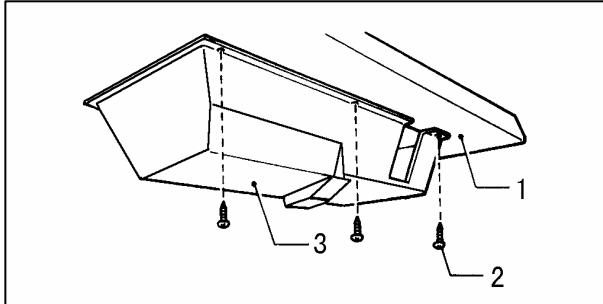

3) Operation panel

(1) Install the operation panel 1 to the set plate 2 with the three screws 3.

(2) Install the set plate 2 to the back of the machine arm with the two screws 4.

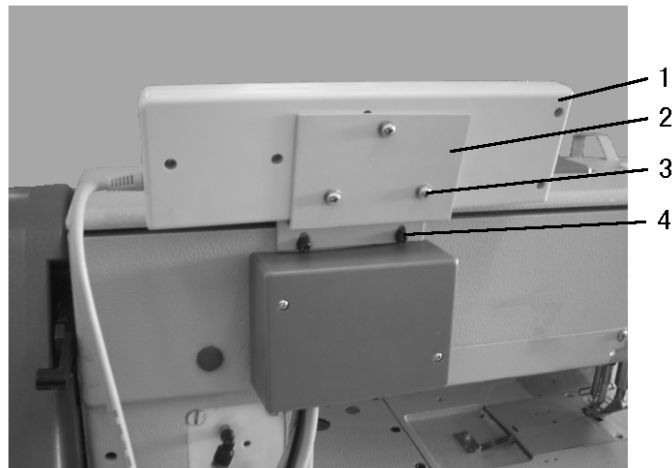

4) Adjusting the needle stop position

(1) Adjusting the needle up stop position

When the sewing machine stops in the needle up stop position (the stop position of trimming) and the treadle is pressed back, the red mark on the pulley should be consistent with the mark on the belt cover A. Adjust as follows:

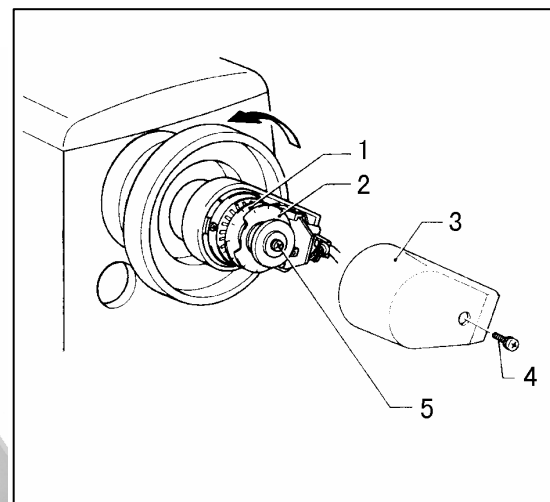
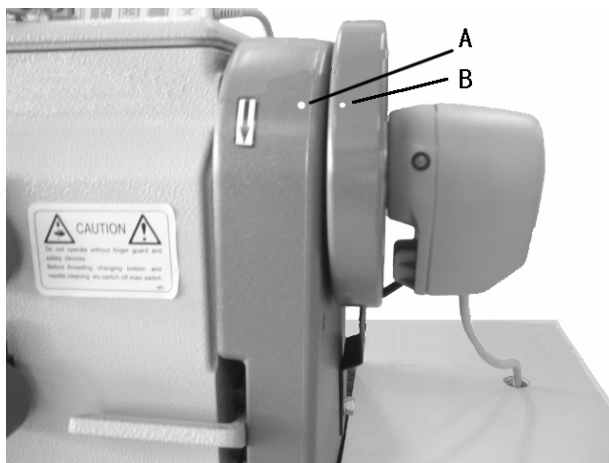

a. Turn off the power switch.

b. Loosen the screw 4, and then remove the cover 3.

c. When the red mark stops in a position over the mark on the belt cover, the needle up stop position disc 1 should be turned in the opposite direction as the direction of machine pulley rotation. When the red mark stops in a position under the mark on the belt cover, Turn the disc 1 in the same direction as the pulley rotation direction.

(2) Adjusting the needle down stop position

When the sewing machine stops in the needle down stop position, the black mark on the pulley should be consistent with the mark on the belt cover A. Adjust as follows:

a. Turn off the power switch.

b. When the black mark stops in a position over the mark on the belt cover, the needle down stop position disc 2 should be turned in the opposite direction as the direction of machine pulley rotation. When the black mark stops in a position under the mark on the belt cover, Turn the disc 2 in the same direction as the pulley rotation direction.

c. After adjusting, install the cover 3, with screw 4.

Note: There is no need to loosen the screw 5, when turning the discs.

5) Lubrication

Before the new machine is used, please loosen the screw 2 and full the oil into the oil case. Set the oil level between “EMPTY” and “FULL”. Then replace oil-filling screw 2.



4. HOW TO USE THE MACHINE

1) Threading

Raise the thread take-up lever to its highest position and thread the upper thread in the following order.

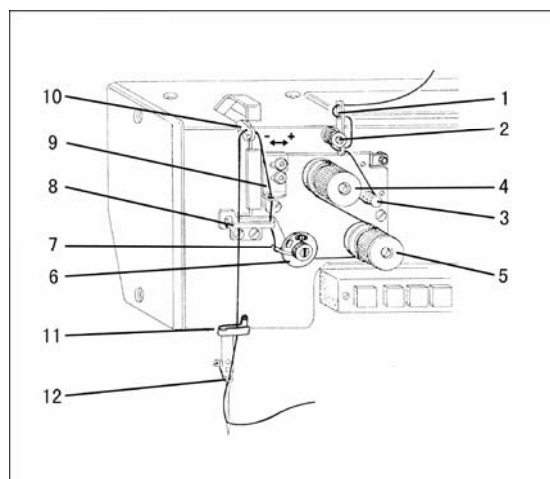

2) Adjusting of the thread regulator

The thread regulator 9 (see the right picture) regulates the amount of needle thread necessary for stitch formation. The setting depends on the following factors: material thickness, yarn characteristics and stitch length.

The thread regulator is fitted with slots for this purpose. Moving in the “+” direction increases the quantity of needle thread; Moving in the “-” direction reduces the quantity of needle thread.

3) Adjusting of upper thread tension

Tension should be as low as possible. The crossover point should be in the center of the material. Upper thread tension can be adjusted by thread tension nut 4 and 5 (see the picture of above). Turn the thread tension nut clockwise to increase the needle thread tension. Turn the thread tension nut counter-clockwise to decrease the needle thread tension.

4) Winding the lower thread

(1) Place the bobbin onto the bobbin winder shaft.

(2) Pass the thread for winding thread as shown in the figure, and wind the end of the thread clockwise around the bobbin several times.

(3) Push the bobbin presser 1 toward the bobbin.

(4) The operation will automatically stop when winding is completed. The amount of thread wound onto the bobbin should be a maximum of 80% if the bobbin capacity. The amount of thread would be regulated by screw 2.

(5) After the thread has been wound on, remove the bobbin and cut the thread with the thread-trimming knife 3.

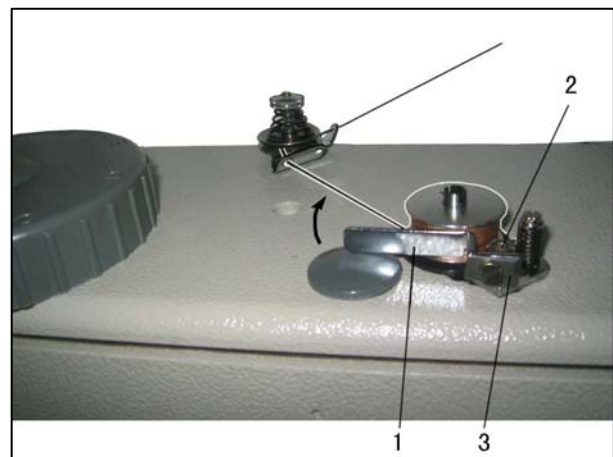

5) Threading the lower thread

(1) Raise flap 1 and remove the empty bobbin.

(2) Insert bobbin 2 in such a way that when the thread is unwound from it moves in the opposite direction to the gripper.

(3) Pass the thread through slit 3 and below spring 6, pass the thread through slit 4 and pull about 3 cm through.

(4) Close flap 1 and pass the thread through the flap's guide 5.

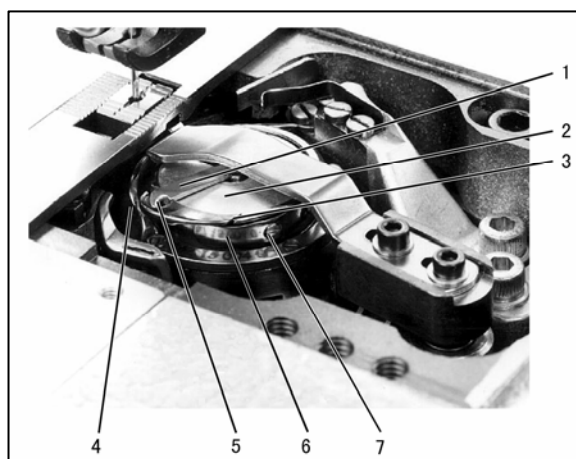

6) Adjusting the lower-thread tension

The lower-thread tension should be set in accordance with the type of seam required. Adjust the tension with screw 7. (See the picture of above)

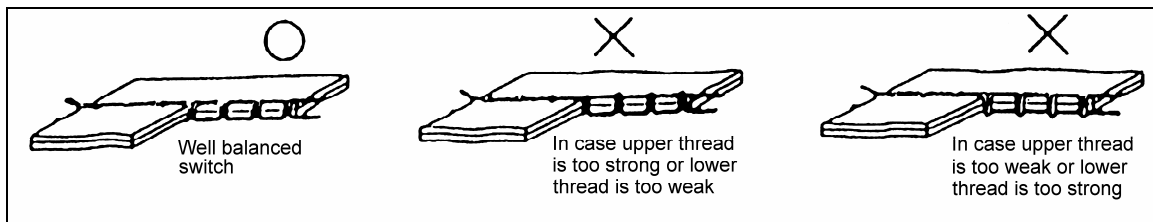

7) Installing the needle

Note: Before attach needle, be sure to turn off the power.

- 1) Turn the balance wheel by hand to raise the needle bar to its highest position;
- 2) Loosen the needle clamping screw;
- 3) Hold the needles so that the two needles side with the long grooved (faces each other), and insert it as deeply as it will go into the needle clamping holes(model GC20688-2-D);Hold the needle to its side with the long groove side(left),then insert the needle as deeply as it will go into the needle clamping hole(model GC20688-1-D).

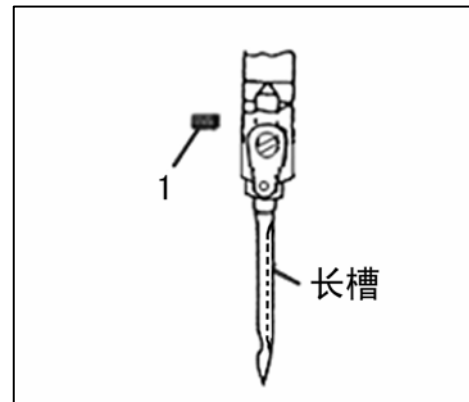

- 4) Tighten the needle clamping screw.

8) Alternating presser foot movement amount

The alternating movement amount for the inner presser foot and the outer presser foot can be adjusted within the range of 1-7 mm using the alternating presser foot movement dial 1. Turn the alternating presser foot movement dial 1 clockwise or counterclockwise to align the mark. (MIN. A, B, C, D, E, F MAX.)

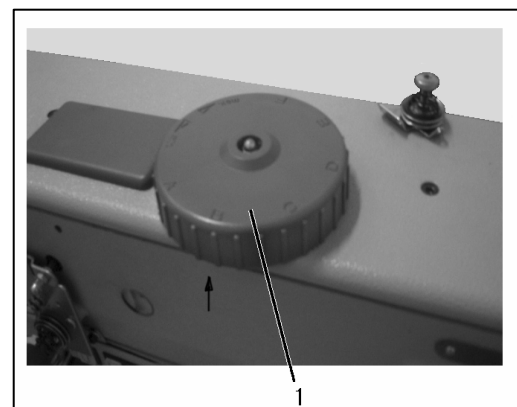

9) Adjusting the presser foot pressure

The presser foot pressure should be set as weak as possible, but strong enough so that the material does not slip. If the presser-adjusting dial 1 is turned clockwise, the presser foot pressure will become stronger, and if it is turned counterclockwise, the pressure will become weaker.



10) Adjusting the stitch length

The feed adjustment dials 2 and 3 can be used to set two different types of stitch length. (See the picture of

above) Use feed adjustment dial 2 to set the big stitch length. Use feed adjustment dial 3 to set the little stitch length. The sewing machine will switch between the two stitch lengths each time the stitch length change switch is pressed.

11) Using the manual switches

(1) Quick reverse switch

Back tacking is carried out during sewing only while the switch 1 is being pressed.

(2) Auto back tacking select switch

If the switch 3 is pressed when either start back tacking or end back tacking has been set to ON at the operation panel, back tacking is canceled for the first time only. Furthermore, if the switch 3 is pressed when neither starting nor end back tacking has been set, back tacking is carried out for the first time only.

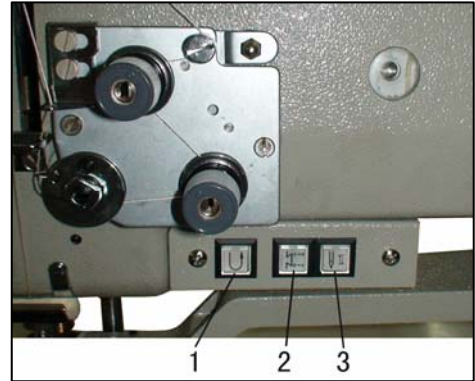

(3) Needle up or down switch

If the switch 4 is pressed, The needle will move up to the needle up stop position from down stop position or move down to the needle down stop position from up stop position.

12) Cleaning

- (1) The area around the feed dog and the hook should be cleaned every day.
- (2) Remove any thread scraps from inside the rotary hook.
- (3) Keep the control box clean.

13) Lubrication

- (1) Check the oil level at the sight glass 1 every week. If the oil is not enough, remove oil-filling screw 2 and pour in oil. Check oil level at sight glass 2. The oil level must be between “EMPTY” and “FULL”. Replace oil-filling screw 2. After running for 500 hours since buying the new sewing machine, the oil must be changed. Then change the oil every two years.



- (2) The oil quantity is pre-set at a relatively high level in order to ensure adequate lubrication during running-in. This setting should be checked and corrected after running-in.

(approx. 50 hours). The hook is to have positive lubrication with the least possible amount of oil. Let the sewing machine run approx. 2 minutes. And run in intervals.

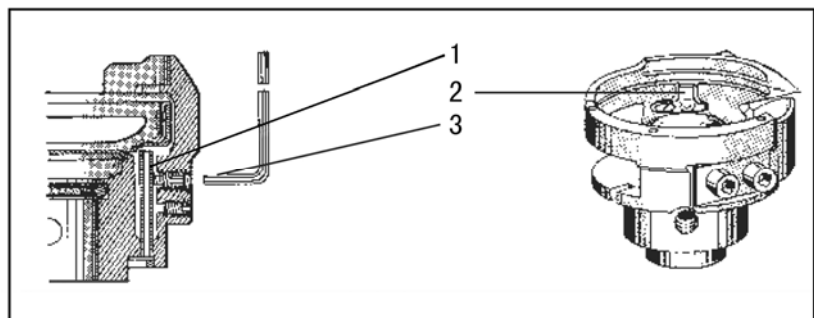

Hold a piece of paper next to the hook and check if sufficient oil is spun onto the paper. Remove cover plate 2. Loosen screw 3 until the tube 1 no longer moves. This is the case when the tube is in the center of the drilled hole. Turn screw 3 in until the tube movement just starts and then a 1/8 turn farther. The hook lubrication is preset. Attach cover plate 2 again. Setting the hook lubrication with screw 3.

(3) Lubricating wicks and felt (see the picture of above)

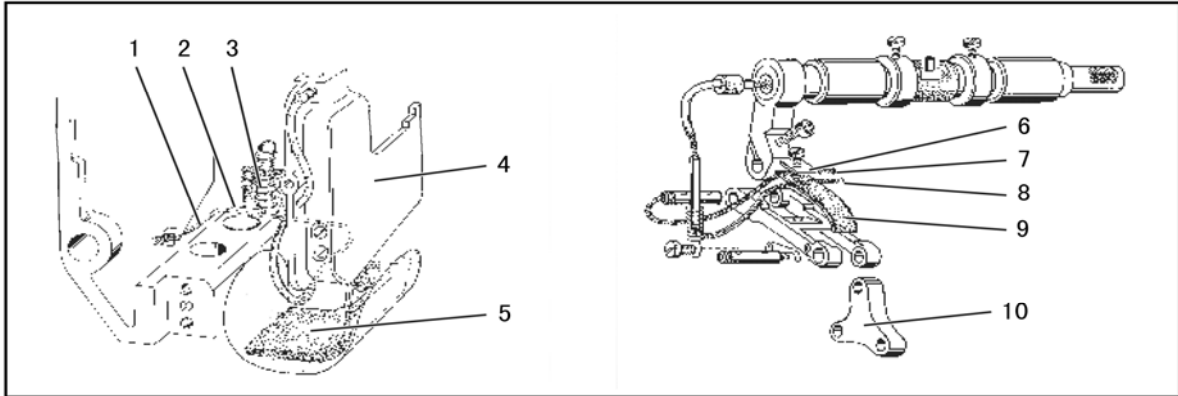

- a. The wick 1 leading from the oil sump to the oscillating crank 4 must be fixed between the groove 2 in the arm and the spring 3 of the recirculation wick.
- b. When the oil satchel is changed, the flock side should be faced to connecting plate 10. The oil wick 7 and 8 should be set between the oil satchel 9 and plate 8.

(4) Checking the lubrication oil.

Turn on the power switch. Depress the treadle gently and check that the oil level rises in the oil sight glass.



14) Adjusting the trailing length after thread trimming

Adjust by turning the pre-tensioner 1. If the tension of the pre-tension is increased, the lengths of the threads trailing from the needle tips will be reduced; if the tension is reduced, the lengths will be increased.

15) Back tacking

When the reverse lever 1 or the quick reverse switch is pressed during sewing, the feed direction will be reversed. When it is released, the feed direction will return to normal.

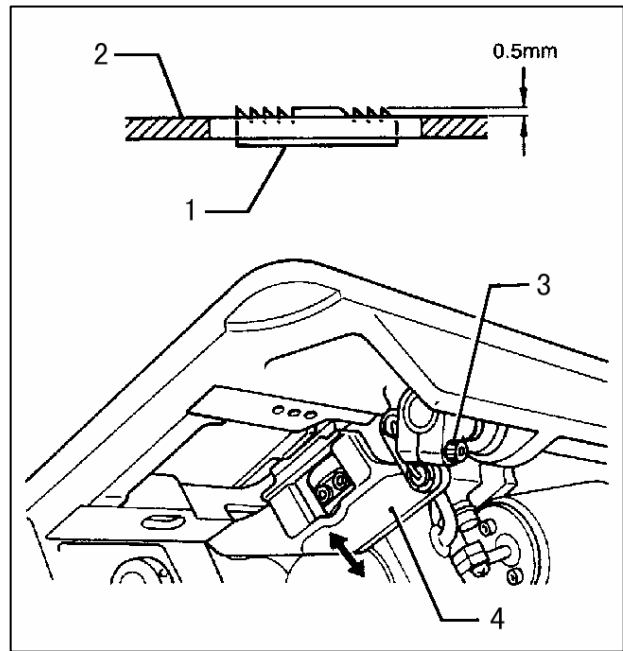
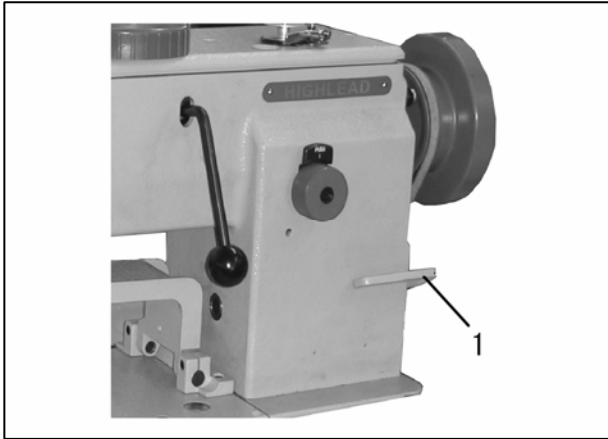

16) Adjusting the feed dog

Set the feed adjustment dials to the minimum settings. Then adjust as follows so that the feed dog 1 is at its highest position (0.5mm above the top of the needle plate 2) when the needle bar is at its lowest position.

- (1) Turn the machine pulley to set the feed dog 1 is at its highest position.
- (2) Loosen the screw 3.
- (3) Adjust the feed dog's height.
- (4) Tighten the screw 3.

17) Adjusting the needle bar height

Set the feed adjustment dials to the minimum settings. Then adjust so that the distance from the setting surface of the needle plate 2 to the end of the needle bar 1 is 18.5mm when the needle bar 1 is at its lowest position.

Set the feed adjustment dials to the minimum settings. Then adjust so that the distance from the setting surface of the needle plate 2 to the end of the needle bar 1 is 18.5mm when the needle bar 1 is at its lowest position.

- (1) Remove the face plate.
- (2) Set the feed adjustment dials to "0".
- (3) Turn the pulley to set the needle bar 1 to its lowest position.

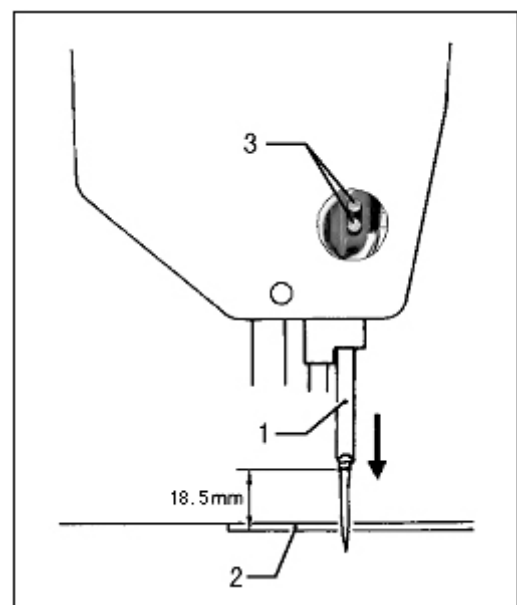

(4) Loosen the screw 3 and then move the needle bar 1 up or down to adjust so that the distance from the setting surface of the needle plate 2 to the end of the needle bar 1 is 18.5 mm.

(5) Tighten the screw 3, install the face plate.

18) Adjusting the gap between the needle and the rotary hook tip

The gap between the needle and the rotary hook tip 1 is 0.1 mm.

Set the rotary hook tip at the level of the middle of the needle. Then adjusting the gap as follow:

(1) Loosen the screws 2 and 5 (see the picture of below).

(2) Set the hook base 6 to the fit position.

(3) Rotate the adjusting plate 3, let the hook base 6 depend on the bed plate 4.

(4) Tighten the screws 2 and 5.

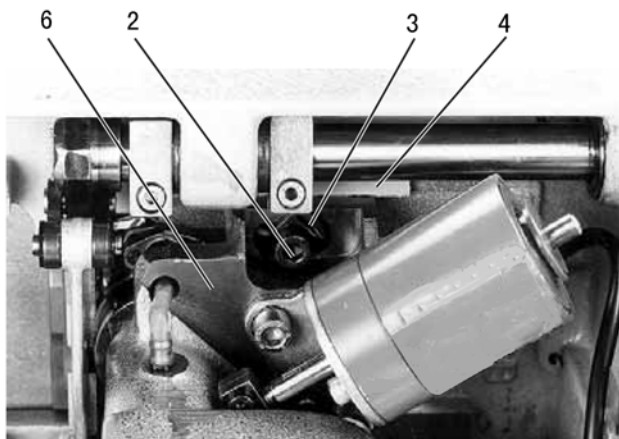
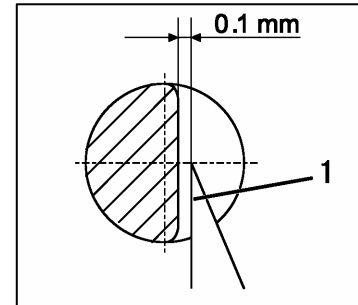

19) Adjusting of the needle and the hook timing

(1) Set the stitch length to "0".

(2) Remove the needle plate.

(3) Overturn the arm.

(4) Loosen the screw 1

(5) Turn the machine pulley to raise the needle bar from its low position to the point that the needle rises 2mm.

(6) Turn the rotary hook to align the rotary hook tip with the center of the needle.

(7) Tighten the screw 1.

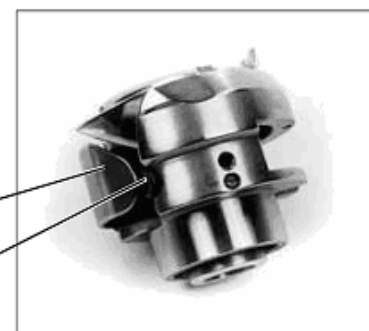
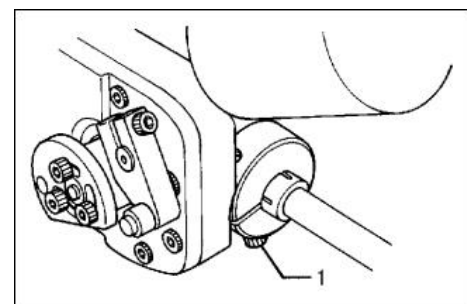

20) Hook protection

In looping stroke position the needle must abut on the hook

protection 1 without being displaced.

Move needle in looping stroke position by pulley. In looping stroke position the hook tip is at the level of the middle of the needle. Press needle against hook protection 1 manually. The needle should not touch the hook tip.

21) Adjusting the needle and feed mechanism timing

(1) Horizontal feed direction

Set the feed adjustment dials to the maximum settings. Then turn the machine pulley until the needle bar is at its lowest position. Then adjust so that the needle and the feed dog do not move even when the reverse lever is moved up and down at this time.

- a. Remove the bed upper cover 1.
- b. Set the feed adjustment dial to the maximum settings.
- c. Loosen the two screws 2.
- d. Turn the machine pulley until the needle bar is at its lowest position.

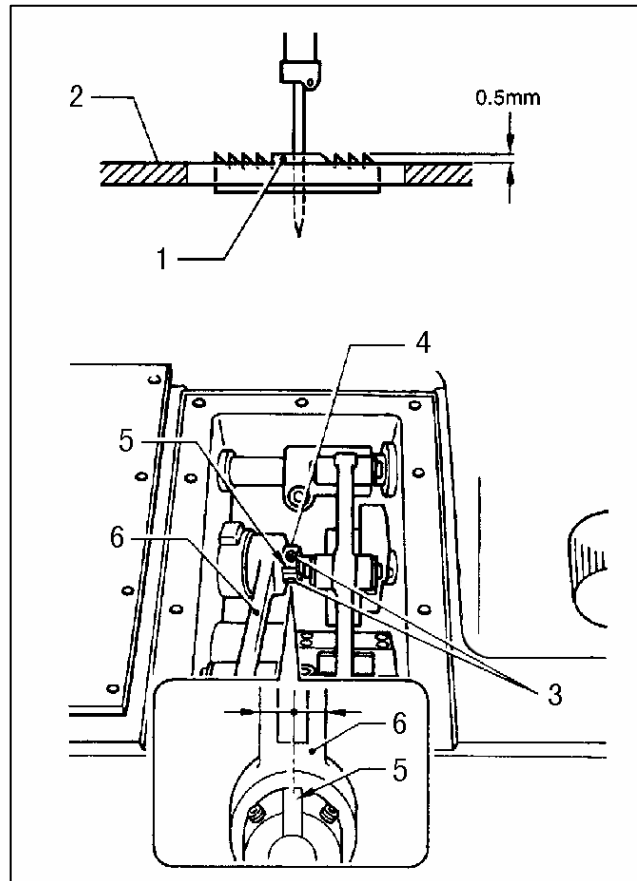
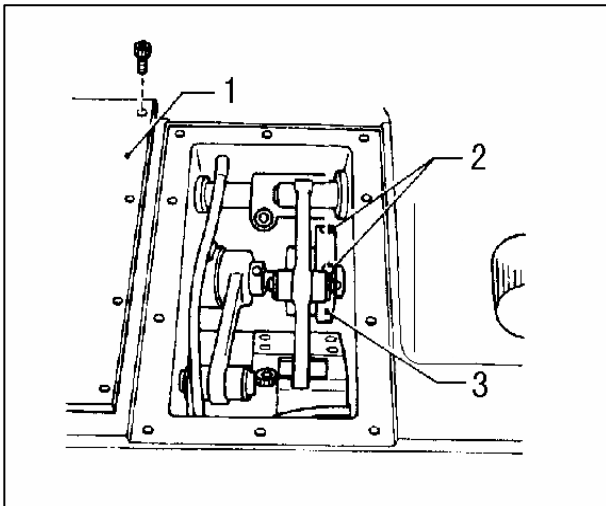

e. Turn the lower feed cam 3 gradually until it is at the position where the needle and the feed dog do not move even when the reverse lever is moved up and down.

- f. Tighten the two screws 2.

(2) Vertical feed direction

Set the feed adjustment dials to the minimum settings. Then adjust as follows so that the feed dog 1 is at its highest position (0.5mm above the top of the needle plate 2) when the needle bar is at its lowest position.

- a. Loosen the two screws 3
- b. Turn the machine pulley to set the needle bar to its lowest position.
- c. Turn feed cam 4 to align the point 5 of feed cam 4 with the centerline of feed rod 6

d. Tighten the screws 3

22) Adjusting the opener position

Adjust so that the clearance between the needle plate 3 and the stopper 4 of the inner rotary hook 2 is 0.5-0.7 mm when the opener 1 is at its closest position to the inner rotary hook 2.

(1) Turn the machine pulley to move the opener 1 in direction “a” (opening direction), and then loosen the screw 5

(2) Turn the machine pulley to move the opener 1 in direction “b” (closing direction), and then loosen the screw 6.

(3) Turn the machine pulley to move the opener 1 as close to the inner rotary hook 2 as possible.

(4) While pressing the opener 1 against the inner rotary hook 2 with your finger, adjust so that the clearance between the needle plate 3 and the stopper 4 of the inner rotary hook 2 is 0.5-0.7 mm.

(5) Tighten the screw 6.

(6) Turn the machine pulley to move the opener 1 in direction “a” (opening direction), and then tighten the screw 5.

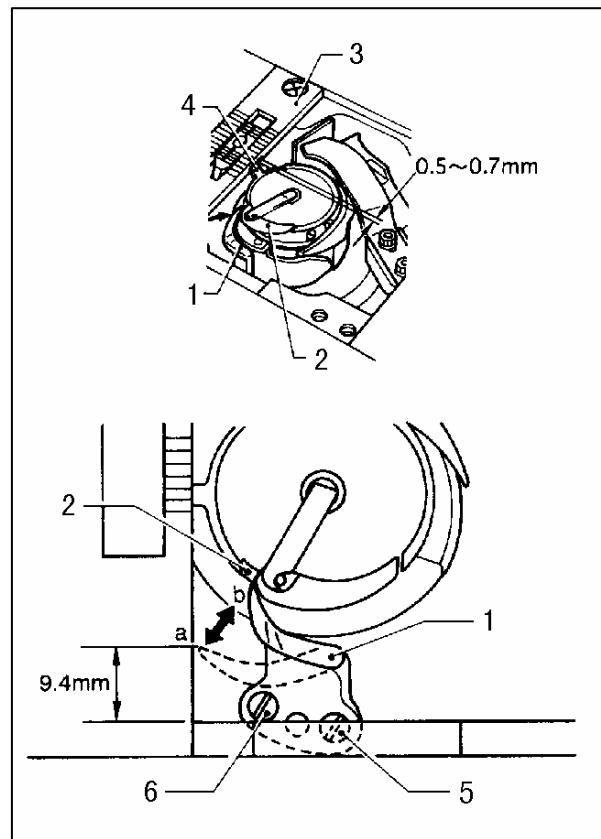

23) Adjusting the presser foot height

The standard height of the outer presser foot 7 is 9 mm when it is raised by the presser lifter bar 1.

(1) Remove the belt cover.

(2) Loosen the presser adjusting screw, to release the presser foot pressure.

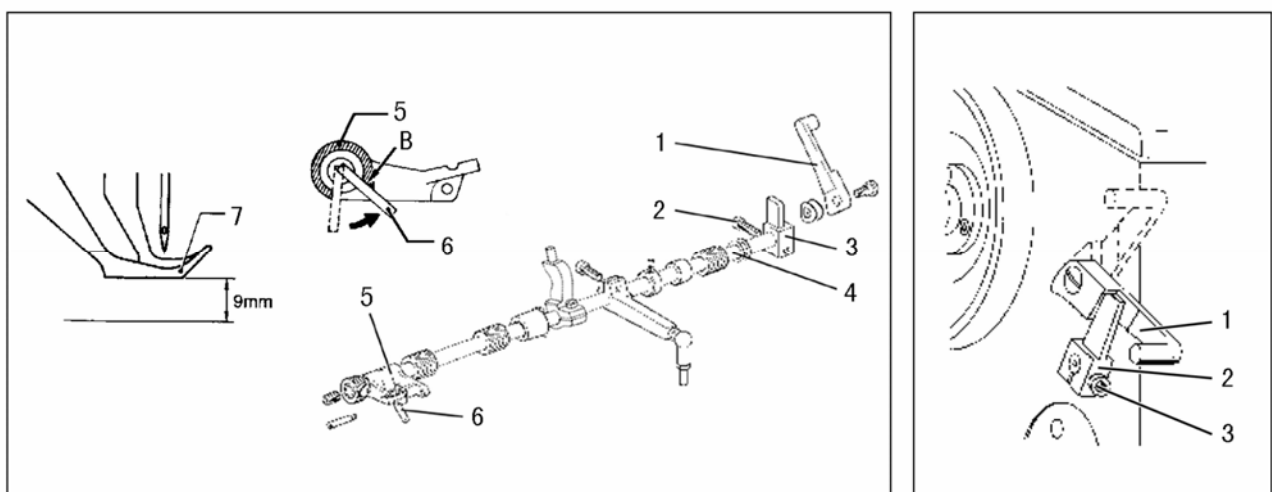

(3) Raise the presser lifters bar 1 and then loosen the screw 2.

(4) Move the outer presser bar up or down to adjust so that the height of the outer presser foot 7 is 9 mm.

(5) While the stopper pin 6 is touching against the notch B in the presser foot lifter connection 5 and while pushing the presser lifter shaft so that there is no play in the thrust direction, tighten the screw 2.

(6) Turn the presser adjusting screw to adjust the presser foot pressure.

(7) Install the belt guards.

24) Adjusting the alternating presser foot movement amount

(1) Maximum alternating presser foot movement amount. Carry out the following adjustment to set the maximum alternating movement amounts for the inner presser foot 1 and outer presser foot 2 to the maximum of 7 mm.

a. Remove the upper plate.

b. Remove the adjusting bracket 3.

c. Loosen screw 5 of adjusting bracket collar 4.

d. Adjust the adjusting bracket collar 4. If the adjusting bracket collar 4 is be installed at the highest position, the alternating presser foot movement amount is 1-6mm. If it is at the lowest position, the alternating presser foot movement amount is 1.6-7mm.

e. Tighten the screw 5.

f. Install the adjusting bracket 3.

d. Loosen the bolt 6 and turn connecting lever 7 to adjust so that the distance from the outer edge of the arm to the outer edge of the pin 7 is 78 mm at this time. Then tighten the bolt 6. (When installing the upper plate, set the alternating presser foot movements dial to the “min.” position.)

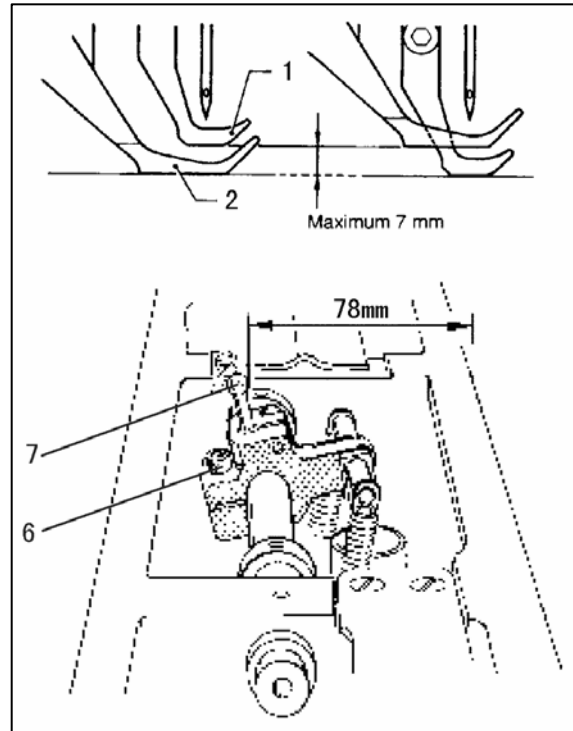

the outer edge of the pin 7 is 78 mm at this time. Then tighten the bolt 6. (When installing the upper plate, set the alternating presser foot movements dial to the “min.” position.)

(2) Inner presser foot 1 and outer presser foot 2 movement amounts. Carry out the following adjustment to make the movement amounts for the inner presser foot 1 and outer presser foot 2 equal when the presser feet

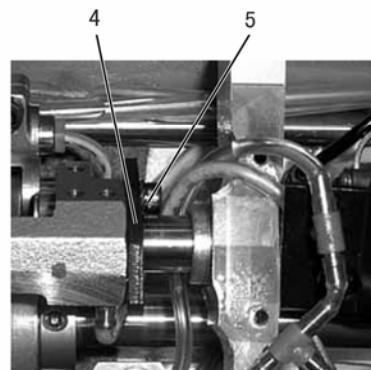
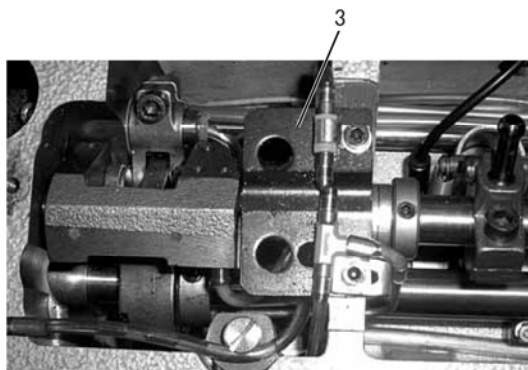

are lowered and the machine pulley is turned.

a. Set the feed adjustment dials to the maximum settings.

b. Open the cover 4

c. Turn the alternating presser foot movement dial to the “B” position.

d. Loosen the screw 3

e. Turn the machine pulley toward you to align the tip of the needle and the top of the feed dog with the top of the needle plate.

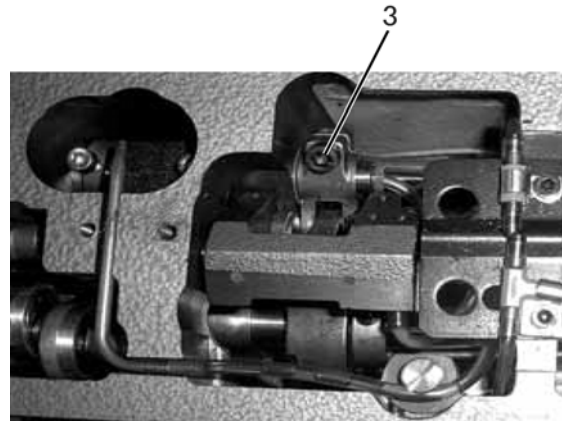

f. Move the connecting lever to adjust so that both the inner presser foot 2 and outer presser foot 1 are in contact with the top of the needle plate at this time. Then tighten the screw 3.

25) Adjusting the presser foot timing

When the presser feet are lowered and the machine pulley is turned toward you. The inner presser foot should touch the feed dog before the needle arrives at the feed dog. Then when the needle lifts up, the tip of the needle should move away from the feed dog before the inner presser foot moves away.

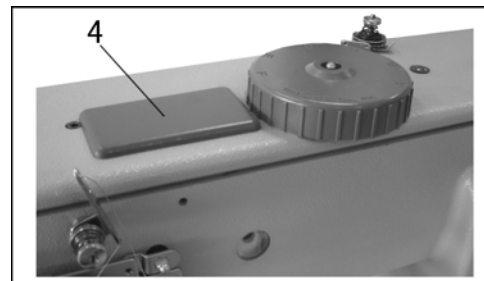

(1) Remove the upper cover 4.

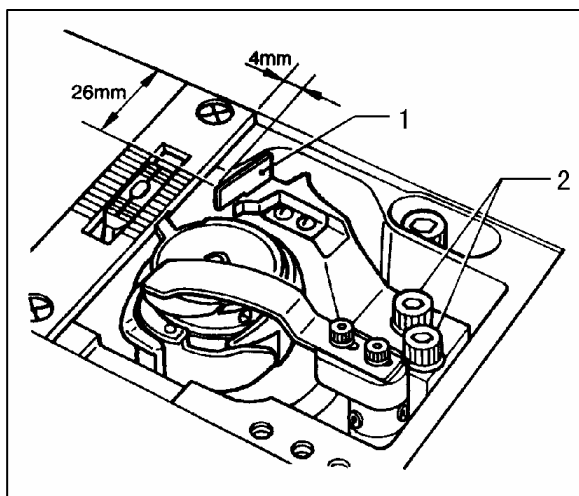
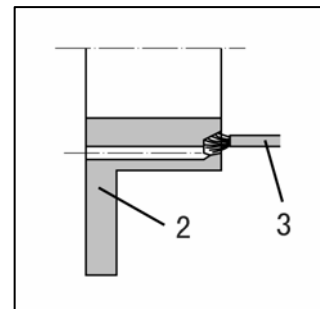

(2) Loosen the two screws 1.

(3) Turn the machine pulley until the needle tip and the feed dog's up face is the same plane.

(4) Turn inner presser cam to adjust so that the point of inner presser cam is facing straight up.

(5) Tighten the screws 2.

(6) When installing the upper plate, set the alternating presser foot movement dial to the “MIN.” position.

26) Adjusting the fixed knife position

The distance from the groove of slide plate to the fixed knife 1 should be 26 mm. Furthermore, the distance from the edge of the needle plate to the left edge of the tip of the fixed knife 1 should be 4 mm.

- (1) Loosen the two bolts 2.
- (2) Adjust the position of the fixed knife 1, and then tighten the bolts 2.

27) Adjusting the thread holding spring position (see the picture of above)

The thread holding spring 1 holds the lower thread after thread trimming to prepare it for the next sewing operation. The clearance between the thread holding spring 1 and the side of the fixed knife 2 should be 1.4-1.6 mm.

- (1) Loosen the two screws 3.

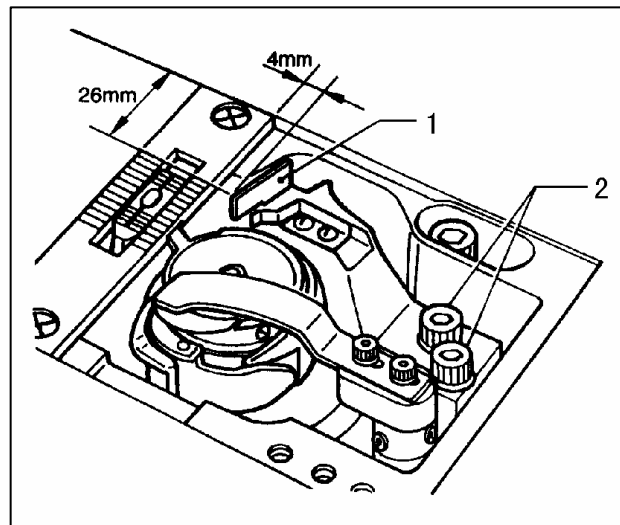
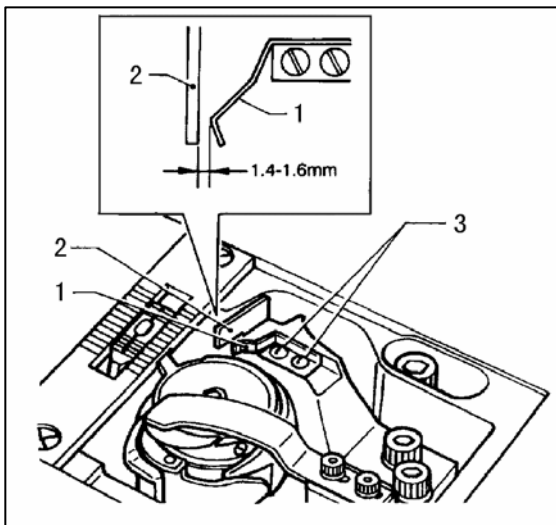

- (2) Move the thread holding spring 1 to adjust its position, and then tighten the screws 3.

28) Adjusting the knife timing position

After adjusting the position of the fixed knife 1, adjust the knife timing position.

Adjust so that the driving knife 1 starts touching the fixed knife at a position 5.5 mm along the front edge of the driving knife 1.

- (1) Loosen the two bolts 3 and 4.
- (2) Move the driving knife 1 to the left or right to adjust its position.
- (3) Then tighten the bolts 3 and 4.

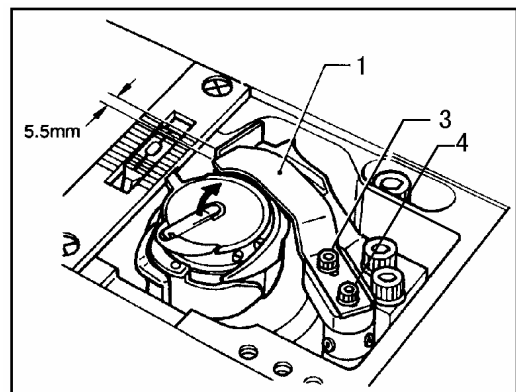

29) Adjusting the driving knife height

The clearance between the lower blade edge of the driving knife 1 and the lower surface of the inner rotary hook should be 0.3-0.4mm.

- (1) Loosen the two screws 2 and 5.

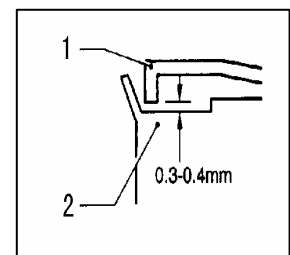

(2) Move the driving knife shaft 6 up or down to adjust the position of the driving knife 1.

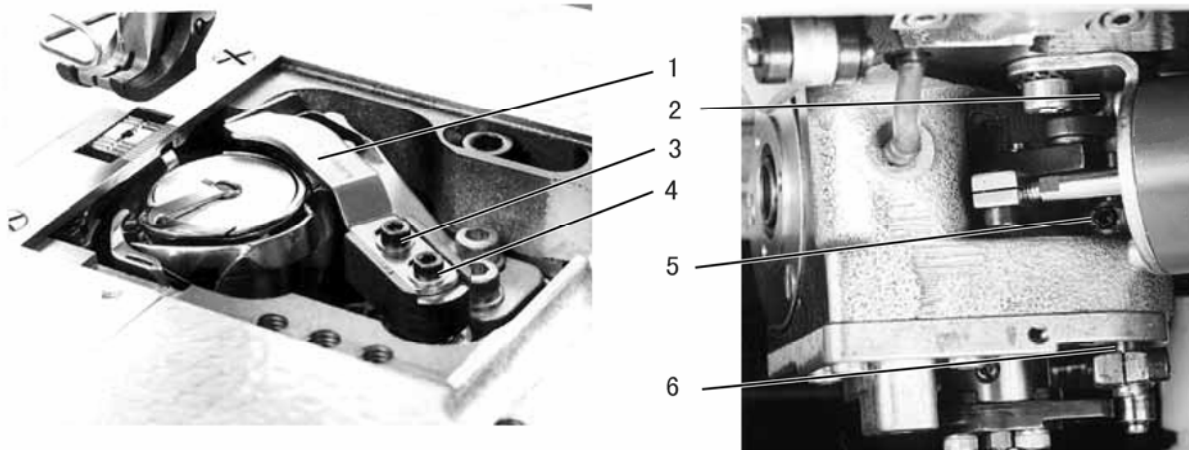

(3) Tighten the screws 2 and 5 on the setting collars again.

30) Adjusting the driving knife stop position

The distance from the blade of the fixed knife 2 to the end of the driving knife 1 should be 0.5mm when the driving knife 1 has moved as far as possible toward the fixed knife 2.

(1) Tilt back the machine head.

(2) Turn the machine pulley to move the roller 6 of the driving knife arm 5 to the outermost side (right side) of the thread trimmer cam 7.

(3) Loosen the bolt 4.

(4) Move the driving knife 1 so that the distance between the blade of the fixed knife 2 to the end of the driving knife 1 is 0.5 mm, and then tighten the bolt 4.

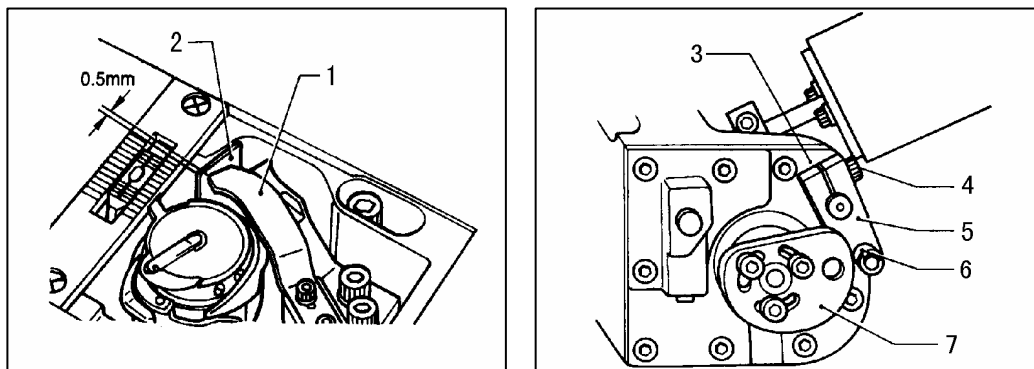

31) Adjusting the driving knife operating position

The standard distance from the left side of driving knife arm 1 to the screw tip on the plunger 2 of the thread trimming solenoid is 1 mm. The clearance between the outermost side (right side) of the thread trimmer cam 5 and the roller 6 of the driving knife arm should be 0.1 mm.

(1) Overturn the arm.

(2) Loosen the bolt 3

(3) Turn the plunger 2 of the thread trimming solenoid so that the distance from the left side of driving knife arm 1 to the screw tip on the plunger 2 of the thread trimming solenoid is 1 mm, and then tighten the bolt 3.

(4) Loosen the bolt 4.

(5) Set the plunger 2 to the position where it projects as far as possible to the left.

(6) Turn the machine pulley to move the roller 6 of the driving knife arm to the outermost side (right side) of the thread trimmer cam 5.

(7) Move the roller 6 so that the clearance between the outermost side (right side) of the thread trimmer cam 5 and the roller 6 is 0.1mm, and then tighten the bolt 4.

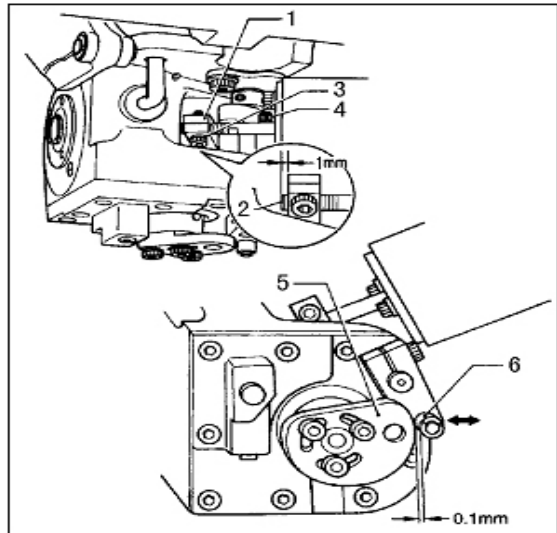

32) Adjusting the thread trimming timing

The center of the pin 1, the center of the reference hole 3 and the center of the roller 4 of the driving knife arm should be in a straight line when the thread take-up lever is at the highest position. (The white point on the pulley and the point on the belt cover are in a straight line.)

(1) Turn the machine pulley until the white point on the pulley and the point on the belt cover are in a straight line.

(2) Overturn the arm.

(3) Loosen the three bolts 5

(4) Turn the thread trimmer cam 2 to adjust the position of the thread trimmer cam 2 so that the center of the pin 1, the center of the reference hole 3 and the center of the roller 4 of the driving knife arm are in a straight line.

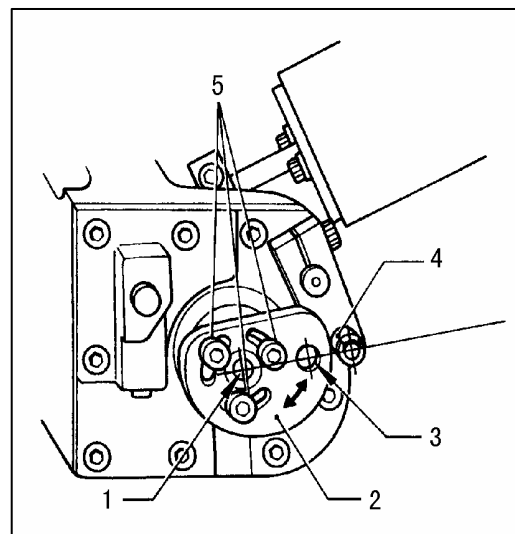

(5) Tighten the bolts 5.

33) Safety clutch

The standard safety clutch 2 in the lower toothed belt wheel protects the hook from being displaced or damaged in case of thread jamming in the hook path. When the hook is blocked, the safety clutch 2 must come out.

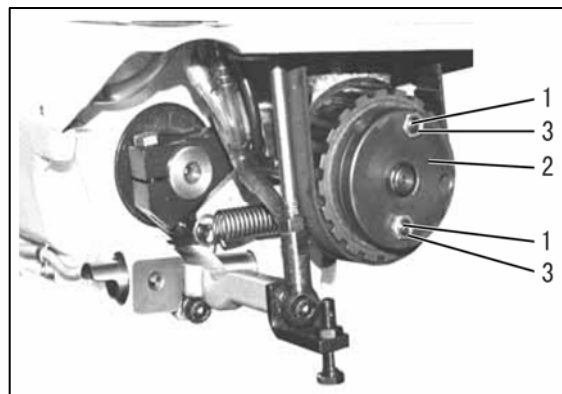
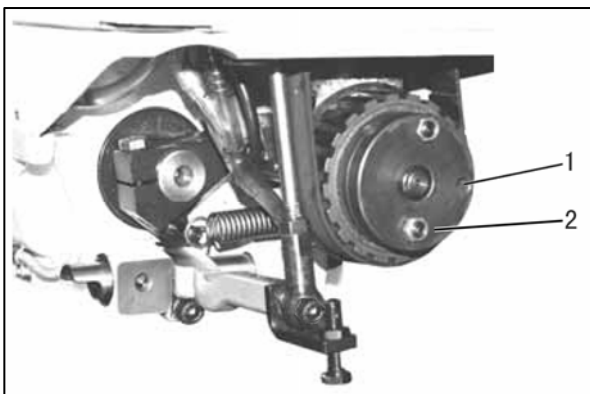

- (1) Set free blocked hook.
- (2) Stick a pin in drill-hole 1 of the outer clutch disc.
- (3) Turn the pulley until the pin can be stuck in the drill-holes of both clutch parts.
- (4) Turn the pulley forwards and backwards until the hook is freely movable again.
- (5) Pull out pin.
- (6) Hold down hook and turn the pulley until safety clutch 2 engages.

Adjust transmittable torque

Standard checking

The supplier by means of a torque spanner should adjust the torque transmittable from safety clutch .

- (1) Loosen counter-nuts 3.
- (2) Adjust torque
- (3) Tighten counter-nuts 3 again.

34) Regulate the atmospheric pressure

When the air cylinder works normally, the necessary atmospheric pressure is 5.5~6.5bar. Can find out through the dial plate of the filtering .

(1) Lifting knob 1, clockwise rotation , the pressure increases.

(2)Lifting knob 1, anticlockwise rotation, the pressure is reduced

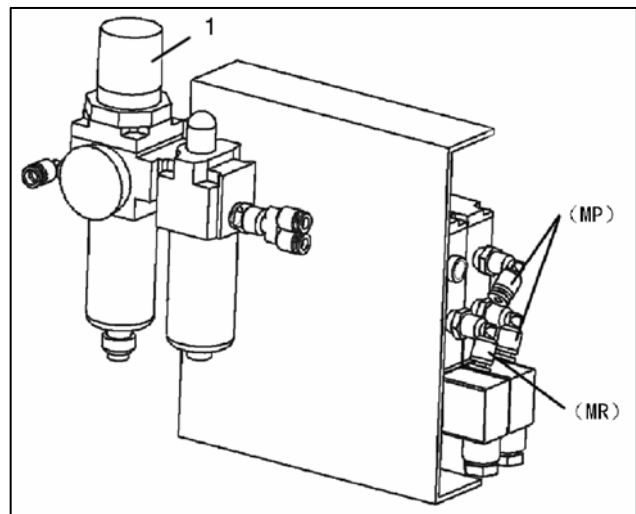

5. HOW TO USE THE VERTICAL CUTTER

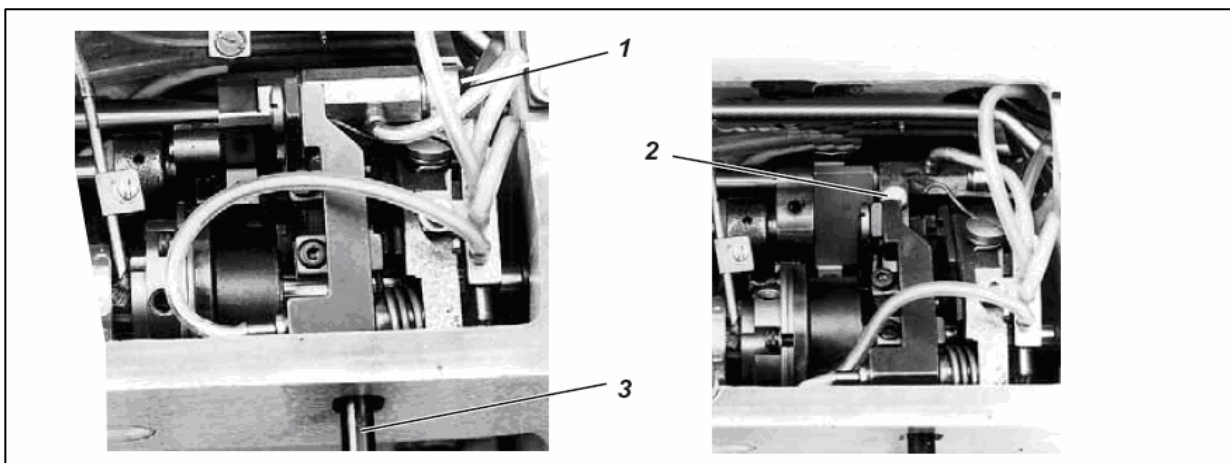

Sewing machines with this device make possible the cutting of the material during the sewing sequence. The vertical cutter does not function during each pneumatic lift of the sewing feet. During operation of the knee lever this is only the case after 2/3 lift. To start the vertical cutter after the operating lever down.

Caution Risk of Injury!

Turn the main switch off. Set the vertical cutter only with the sewing machine turned off.

1) Idle of the knife when the vertical cutter is turned off.

Press the operating lever 3 to the right. The vertical cutter does not function. Turn the hand-wheel. When the vertical cutter is turned off the knife should not move during the sewing machine operation. If it does, then the stop screw 2 is to be set accordingly.

2) Timing of the deactivation of the knife during lifting of the sewing feet with the knee lever

Through this setting a lifting of the sewing feet up to a certain position should be made possible (e.g. to turn the material), without the knife being put out of operation. Loosen gudgeon 1 and set its position. By sewing foot lift with the knee lever, the vertical cutter should be put out of operation when the feet are 2/3 lifted. Tighten gudgeon 1 again.

3) Position of the release block

Loosen screw 1. Turn block 2. With the vertical cutter turned on, the clearance between the release block 3 and the latch 4 should be 0.5mm. the block 2 should not touch the arm shaft. Tighten screw 1 again.

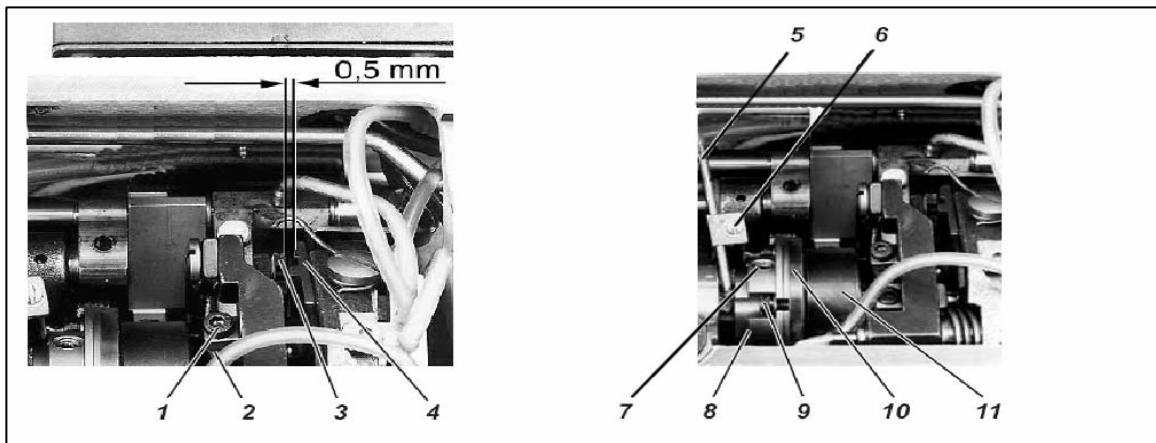

4) Lubrication of the eccentric

Loosen screw 6. Set the position of the oil tube 5. The wick must touch the groove in the eccentric with its knots. Tighten screw 6 again.

5) Stroke of the knife

Loosen screw 9 (3×). Set the position of the eccentric sleeve 10 in the radial direction. The stroke (8 to 12 mm) should be appropriate to the material thickness. A stroke of 8 mm is set at the factory. Tighten screws 9 (3 ×) again. Correct the knife overlap. (See further down in this Chapter)

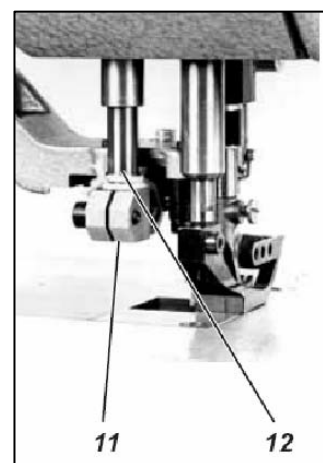
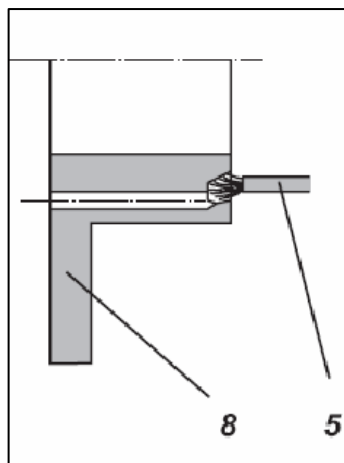
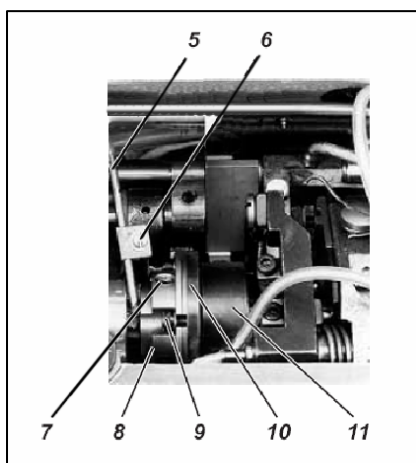

6) Timing of knife movement

Loosen screws 7(2×). Turn eccentric 8 on the shaft. The knife and the presser foot should reach their upper dead centers at the same time. Tighten screws 7(2×) again. The tie rod 11 must touch the groove in the eccentric with its knots.

7) Knife overlap

Prerequisite is that the block 11 is seated flush on the rod 12. This results in an optimum clamping effect. Loosen screw 6. (Insert the wrench through the hole in the housing wall). Turn shaft 5. When the knife 9 is at the lower dead center the overlap should be 0.5mm. Tighten screw 6 again. The block 7 should not touch the link 8.

Note: When the knife has been reground often it may no longer be possible to set the overlap of 0.5mm. In this case the spacer plate 4 can be moved from below the knife carrier 3 to above the knife carrier.

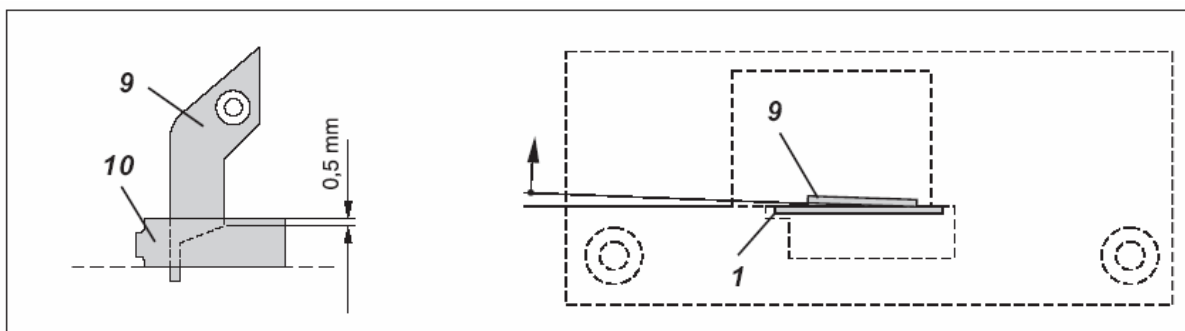
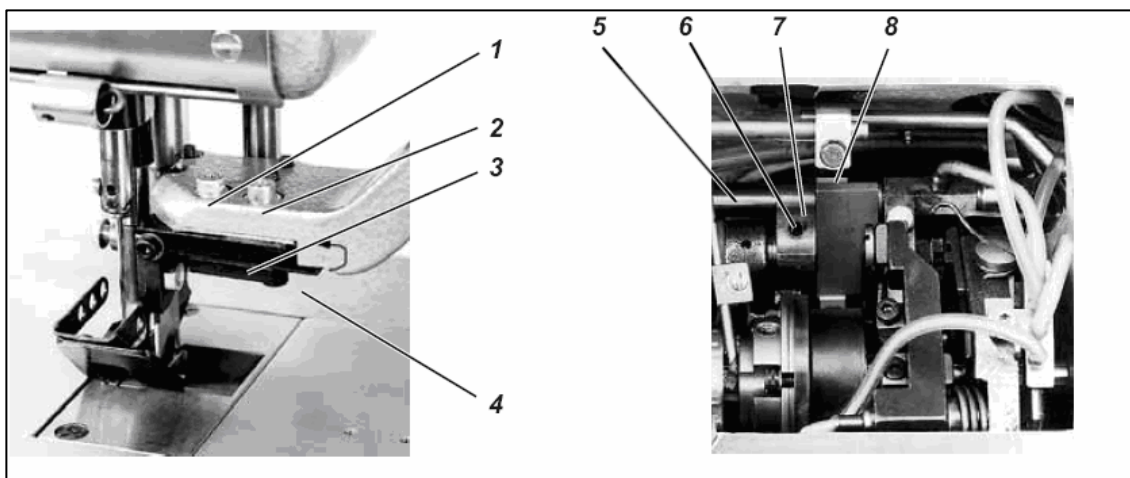

8) Setting and pressure of the knife blades

Loosen screws 1 and 2. Set the position of the knife. The knife 9 should lie a little inclined to the counter knife 10. The knife should cut securely with the least possible pressure. Tighten screws 1 and 2 again.

Note: The higher the knife pressure, the higher the knife wear!

A. ARM BED MECHANISM

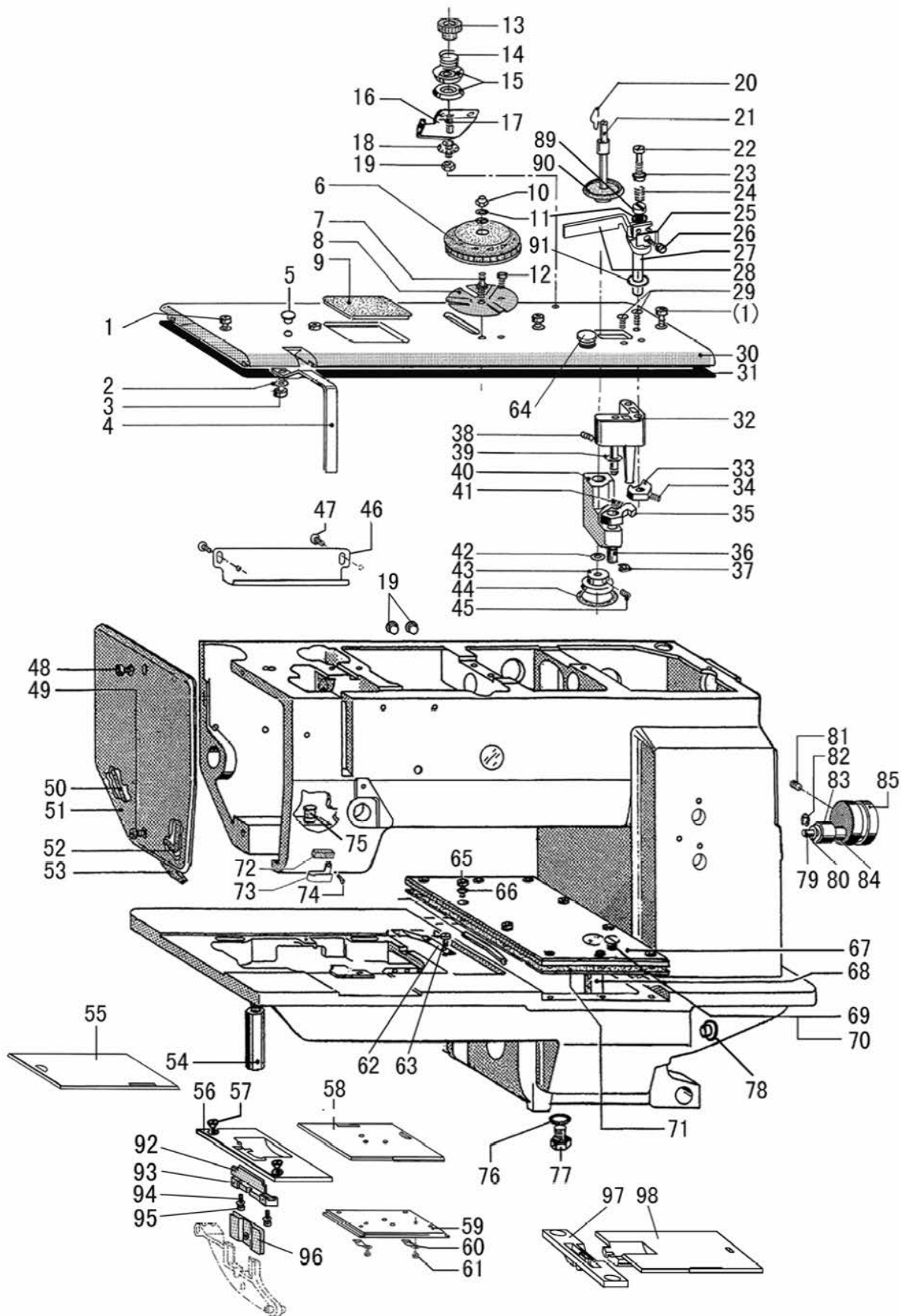

A.ARM BED MECHANISM

Fig. No.	Part No.	Description	GC20688-DC	GC20688-BDC	Remarks
A01	HF914B8001	Screw M5×12	4	4	
A02	H005001040	Washer	1	1	
A03	H415040080	Screw	1	1	M4×8
A04	HF927B8001	Thread take-up cover	1		
A04	HE41B38001	Thread take-up cover		1	
A05	HF930B8001	Plug	1	1	
A06	HF933B8001	Dial	1	1	
A07	HF935B8001	Dial shaft	1	1	
A08	HF936B8001	Guard plate	1	1	
A09	HF931B8001	Cover	1	1	
A10	H003024040	Hexagonal nut	1	1	M4
A11	H005001040	Washer	2	2	
A12	H401040060	Screw	1	1	M4×6
A13	HA710B0671	Pre-tension adjusting nut	1	1	
A14	H6739B8001	Thread tension spring	1	1	
A15	HA310B0705	Thread tension discs	2	2	
A16	H6736B8001	Thread guide	1	1	
A17	HF974B8001	Thread tension stud	1	1	
A18	H7212I8001	Washer	1	1	
A19	H4715B8001	Plug	2	2	
A20	HF965B8001	Fixing clamp	1	1	
A21	HF964B8001	Winder shaft	1	1	
A22	H401030120	Screw	1	1	M3×12
A23	HF952B8001	Disc	1	1	
A24	H5731F8001	Presser spring	1	1	
A25	HF954B8001	Knife	1	1	
A26	H401030040	Screw	1	1	M3×4
A27	HF947B7101	Release lever	1	1	
A28	HF949B8001	Winder lever	1	1	
A29	H403040080	Screw	2	2	M4×8
A30	HF922B8001	Arm cover	1	1	
A31	HF923B8001	Washer	1	1	
A32	HF942B7101	Winder block	1	1	
A33	HF944B8001	Release cam	1	1	
A34	H431050060	Screw	1	1	M5×6
A35	HF958B8001	Block	1	1	
A36	HF956B8001	Bushing	1	1	
A37	H007013035	E-type stop ring 3.5	1	1	
A38	HF961B8001	Presser spring	1	1	
A39	HF957B8001	Washer	1	1	
A40	HF960B8001	Arm	1	1	
A41	HF959B8001	Presser spring	1	1	
A42	HF966B8001	Washer	2	2	

A.ARM BED MECHANISM

Fig. No.	Part No.	Description	GC20688-DC	GC20688-BDC	Remarks
A43	HF967B8001	Winder wheel	1	1	
A44	H7331D8001	Rubber ring	1	1	
A45	H431050050	Screw	1	1	M5×5
A46	HF999B8001	Cord cover	1	1	
A47	H7331G8001	Screw	1	1	
A48	HF914B8001	Screw M5×12	1	1	
A49	HF915B8001	Screw M5×12	1	1	
A50	HF918B8001	Bar	1	1	
A51	HF913B8001	Face plate	1	1	
A52	HF919B8001	Bar	1	1	
A53	HF920B8001	Oil pillow	1	1	
A54	HF998B8001	Leg	1	1	
A55	HE61B68001	Slide Plate	1		
A56	HE61B98001	Needle plate	1		8mm
A56	HE62B38001	Needle plate	1	1	3mm
A57	HF989B8001	Screw	2	2	
A58	HE61B78001	Slide Plate	1		
A59	HF985B8001	Slide Plate	1	1	
A60	HF986B8001	Spring for slide plate	2	2	
A61	H401020025	Screw	2	2	M2×2.5
A62	HF982B8001	Stopper	1	1	
A63	H7331G8001	Screw	2	2	
A64	H4735B8001	Plug	1	1	
A65	HF914B8001	Screw M5×12	10	10	
A66	HF997B8001	Gasket	10	10	
A67	HF991B8001	Cover	1	1	
A68	HF992B8001	Oil indicator	1	1	
A69	HF993B8001	Screw	1	1	
A70	HF994B8001	Gasket	1	1	
A71	HF995B8001	Gasket	1	1	
A72	H3108B0692	Felt	1	1	
A73	H3108B0691	Thread guide	1	1	
A74	HF938C8001	Screw	1	1	
A75	HA307B0674	Rubber plug	1	1	
A76	HF90AB8001	Gasket	2	2	
A77	100010	Screw	1	1	M10×1
A78	HG605H8001	Rubber plug	1	1	
A79	HF981I8001	Pin	1	1	
A80	H7335C8001	Washer	2	2	
A81	H428080120	Screw	1	1	M8×12
A82	H007013060	E-type stop ring 6	1	1	
A83	628ZZ	Bearing	2	2	GB/T 276 628ZZ
A84	HF980I8001	Spacer	1	1	

A.ARM BED MECHANISM

Fig. No.	Part No.	Description	GC20688-DC	GC20688-BDC	Remarks
A85	HF979I8001	Belt tensioner	1	1	
A89	H415040060	Screw	1	1	M4×6
A90	HF970B8001	Bobbin seat	1		
A90	HE41B58001	Bobbin seat		1	
A91	HF946B8001	Washer	1	1	
A92	HE62B08001	Fixed knife	1	1	8mm
A92	HE62B88001	Fixed knife	1	1	3mm
A93	HE62B18001	Fixed knife plate	1	1	
A94	H415030100	Screw	2	2	M3×10
A95	H005004030	Washer	2	2	3
A96	HE60I77101	Pushing plate	1	1	

B. THREAD TENSION REGULATOR MECHANISM

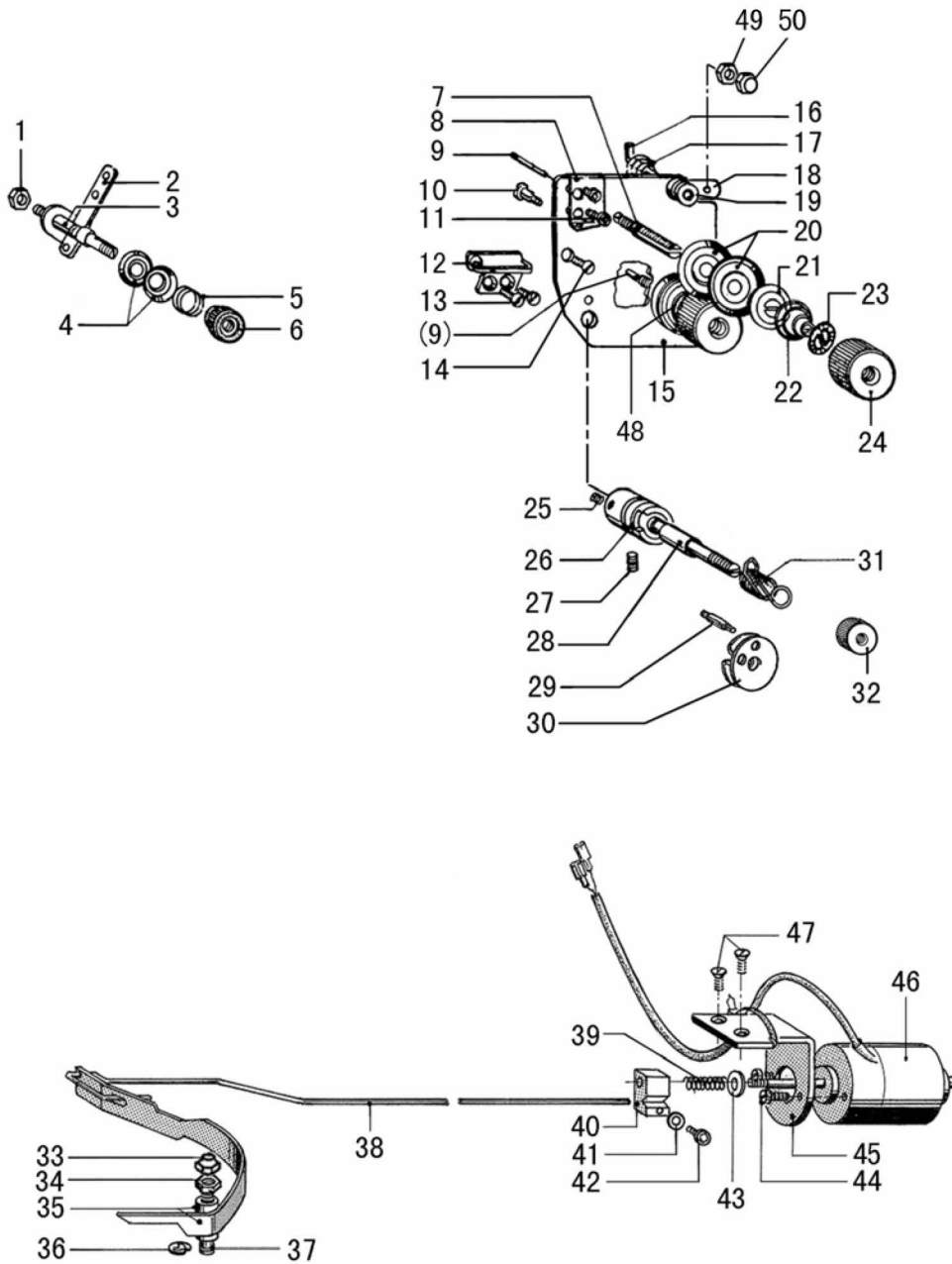

B.THREAD TENSION REGULATOR MECHANISM

Fig. No.	Part No.	Description	GC20688-DC	GC20688-BDC	Remarks
B01	H003002050	Nut	1	2	M5
B02	HF930C8001	Thead hook	1	2	
B03	HF929C8001	Thread tension stud	1	2	
B04	HA112B0693	Thread tension discs	1	2	
B05	HA710B0672	Tension spring	1	2	
B06	HA710B0671	Tension adjusting nut	1	2	
B07	HF907C8001	Thread tension stud	2		
B08	HF917C8001	Thread guide	1	1	
B09	H3221B6817	Thread tension releasing pin	2	1	
B10	H3221B6811	Shoulder screw	2	2	
B11	H7316B8001	Screw	2	2	
B12	HF925C8001	Thread guide	1		
B13	H7322B8001	Screw	2	2	
B14	H7316B8001	Screw	2	2	
B15	HF905C8001	Tension plate	1	1	
B16	HF923C8001	Rod	1	1	
B17	HF924C8001	Sping	1	1	
B18	HF915C8001	Tension release plate	1	1	
B19	HF916C8001	Thread guide	1	1	
B20	HA310B0705	Tension discs	4	4	
B21	HA310B0702	Tension release discs	2	2	
B22	HA115B0703	Tension spring	1		
B23	HA115B7010	Stopper	2	2	
B24	HA310B0701	Tension nut	2	2	
B25	H431040040	Screw	1	1	M4×4
B26	HF936C8001	Thread tension post	1	1	
B27	H431050050	Screw	1	1	M5×5
B28	H4805C8001	Thread tension stud	1	1	
B29	H4804C8001	Screw	1	1	
B30	H32481BD21	Plate complete	1	2	
B31	H4713C8001	Thread take-up spring	1	1	
B32	H32481B721	Thumb nut	1	1	
B33	H003045050	Nut	1	1	M5
B34	H003002050	Nut	1	1	M5
B35	HF918C8001	Release lever	1	1	
B36	H007013050	E-type stop ring 5	1	1	
B37	HF919C8001	Bolt	1	1	
B38	HE60C58001	Hook	1	1	
B39	HF908C8001	Spring	1	1	
B40	HF909C8001	Block	1	1	
B41	H005001040	Washer	1	1	
B42	H415040080	Screw	1	2	M4×8
B43	HF927I8001	Washer	1	1	

B.THREAD TENSION REGULATOR MECHANISM

Fig. No.	Part No.	Description	GC20688-DC	GC20688-BDC	Remarks
B44	H415040100	Screw	2	1	
B45	HF906C8001	Magnet support	1	1	
B46	HF922C8001	Solenoid	1	1	
B47	H403050120	Screw	2	2	M5×12
B48	H4710C8001	Tension spring	1	1	
B49	H003002040	Nut		1	
B50	H003045040	Nut		1	

C. NEEDLE BAR AND THREAD TAKE-UP MECHANISM

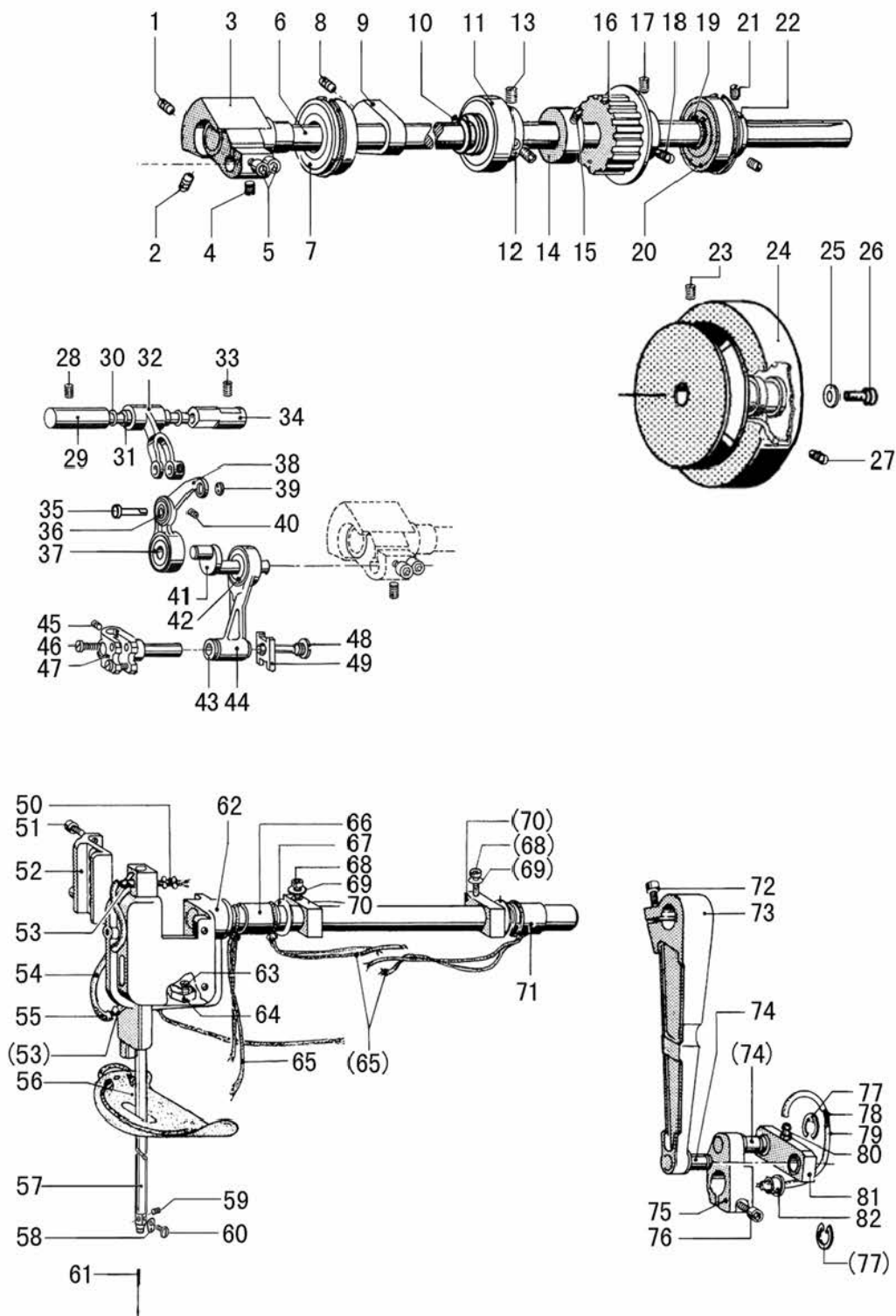

C.NEEDLE BAR AND THREAD TAKE-UP MECHANISM

Fig. No.	Part No.	Description	GC20688-DC	GC20688-BDC	Remarks
C01	H6715C8001	Screw	1	1	
C02	H431060060	Screw	1	1	M6×6
C03	HF907D8001	Crank	1	1	
C04	H431060060	Screw	1	1	M6×6
C05	HF914B8001	Screw	2	2	
C06	HF905D8001	Upper shaft	1	1	
C07	H3205J0662	Ball bearing	1	1	
C08	H431080100	Screw	1	1	M8×10
C09	HF913D8001	Counterweight	1	1	
C10	H007009200	Retainer ring	1	1	
C11	HF921D8001	Ball bearing	1	1	
C12	HF918D8001	Bushing	1	1	
C13	H431060060	Screw	2	2	M6×6
C14	HF943D8001	Bobbin winder driving wheel	1	1	
C15	H431060100	Screw	2	2	M6×10
C16	HF923D8001	Belt pulley(upper)	1	1	
C17	H431060080	Screw	1	1	M6×8
C18	H429060100	Screw	1	1	M6×10
C19	H007009200	Retainer ring	1	1	
C20	HF932D8001	Ball bearing	1	1	
C21	H431060080	Screw	2	2	M6×8
C22	HF929D8001	Bushing	1	1	
C23	H431060100	Screw	1	1	M6×10
C24	HF934D8001	Pulley	1	1	
C25	H005008080	Washer	1	1	
C26	H415080250	Screw	1	1	M8×25
C27	H429060100	Screw	1	1	M6×10
C28	H428050060	Screw	1	1	M5×6
C29	HF913G8001	Thread take-up pin	1	1	
C30	HF918G8001	Gasket	2	2	
C31	H7221G8001	Needle bearing	2	2	
C32	HF916G8001	Thread take-up support	1	1	
C33	H428050120	Screw	1	1	M5×12
C34	HF911G8001	Thread take-up pin bushing	1	1	
C35	HF919G8001	Support screw	1	1	
C36	HF909G8001	Bearing	1	1	
C37	H6722I8001	Bearing	1	1	
C38	HF907G8001	Thread take-up lever	1		
C38	HE40G78001	Thread take-up lever		1	
C39	HF908G8001	Bushing	1	1	
C40	H431030040	Nut	1	1	M3
C41	HF920G8001	Thread take-up crank	1	1	
C42	HF923G8001	Bearing	2	2	

C.NEEDLE BAR AND THREAD TAKE-UP MECHANISM

Fig. No.	Part No.	Description	GC20688-DC	GC20688-BDC	Remarks
C43	HF926G8001	Bushing	1	1	
C44	HF922G8001	Needle bar link	1	1	
C45	H431030050	Screw	1	1	M3×5
C46	HD726G8001	Screw	2	2	M4×12
C47	HF924G8001	Needle bar holder	1	1	
C48	HF928G8001	Threaded bolt	1	1	
C49	HF927G8001	Slide block	1	1	
C50	HF938G8001	Oil wick	1	1	
C51	H415040100	Screw	2	2	M4×10
C52	HF933G8001	Slide guide	1	1	
C53	HF939G8001	Oil feeding pipe	2	2	
C54	HF936G8001	Oil pipe	1	1	
C55	HF937G8001	Oil wick	1	1	
C56	HF940G7101	Rubber	1	1	
C57	HE60G58001	Needle bar	1	1	
C58	HF971G8001	Thread guide	1	1	
C59	H402030040	Screw	1	2	M3×4
C60	HF972G8001	Screw	1	1	
C61	JZDP1700P2301	Needle	1	2	DP×17 #23
C62	HF931G7101	Needle bar bracket	1	1	
C63	H403040100	Screw	1	1	M4×10
C64	HF943G8001	Oil satchel	1	1	
C65	HF947G8001	Oil wick	3	3	
C66	HF927E8001	Bushing	1	1	
C67	HF968G8001	Support disc	2	2	
C68	H415040120	Screw	2	2	M4×12
C69	H005001040	Washer	2	2	
C70	HF965G8001	Collar	2	2	
C71	HF924E8001	Bushing	1	1	
C72	H415060200	Screw	1	1	M6×20
C73	HF962G8001	Upper feed connecting rod	1	1	
C74	HF951G8001	Shoulder screw	1	1	
C75	HF949G8001	Connecting lever	1	1	
C76	H415060160	Screw	1	1	M6×16
C77	H007013080	E-type stop ring 8	2	2	
C78	HF958G8001	Oil wick	1	1	
C79	HF957G8001	Oil pipe	1	1	
C80	HF956G8001	Oil feeding pipe	1	1	
C81	HF952G7101	Pull rod	1	1	
C82	HF959G8001	Plug	1	1	

D. PRESSER FOOT MECHANISM

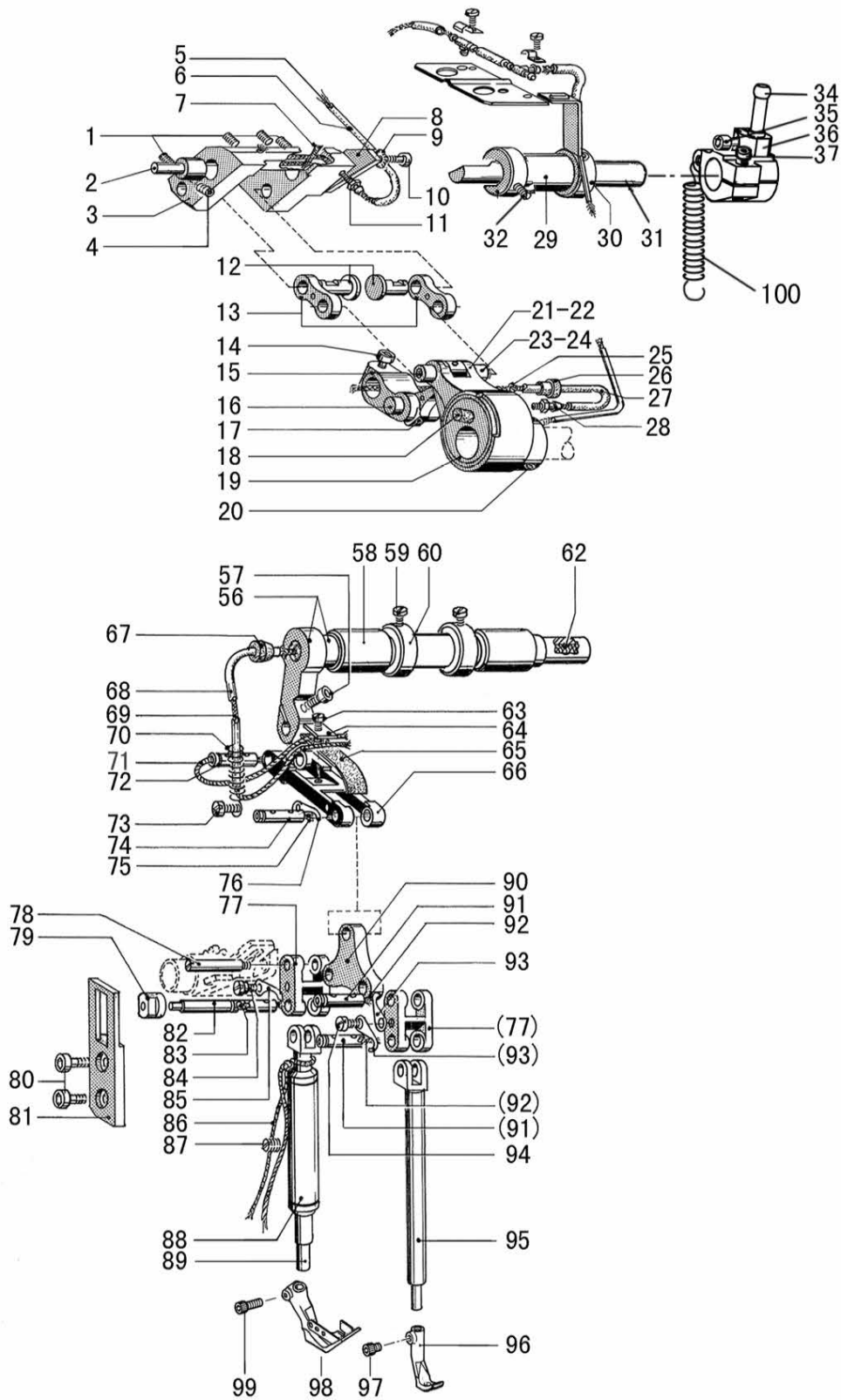

D.PRESSER FOOT MECHANISM

Fig. No.	Part No.	Description	GC20688-DC	GC20688-BDC	Remarks
D01	H428050080	Screw	4	4	M5×8
D02	HF919E8001	Support pin	1	1	
D03	HF906E8001	Adjusting bracket	1	1	
D04	H428050080	Screw	1	1	M5×8
D05	HF912E8001	Oil wick	1	1	
D06	HF911E8001	Oil pipe	1	1	
D07	HF908E8001	Oil wick	2	2	
D08	HF913E8001	Plate	1	1	
D09	H005018050	Washer	1	1	
D10	H415050100	Screw	1	1	M5×10
D100	HE60E88001	Pull spring	1	1	
D11	HF956G8001	Oil feeding pipe	1	1	
D12	HF917E8001	Link pin	2	2	
D13	HF916E8001	Link	2	2	
D14	H415060200	Screw	1	1	M6×20
D15	HF951E8001	Connecting lever	1	1	
D16	HF956E8001	Pin	1	1	
D17	HF953E7101	Link	1	1	
D18	HA104D0652	Plug	1	1	
D19	HF942E8001	Inner presser cam	1	1	
D20	H428060060	Screw	2	2	M6×6
D21	HF946E8001	Inner presser rod	1	1	
D22	HF947E8001	Bearing	1	1	
D23	HF948E8001	Rod pin	1	1	
D24	HF949E8001	Oil wick	1	1	
D25	HF960E8001	Oil wick	1	1	
D26	HF961E8001	Plug	1	1	
D27	HF959E8001	Oil pipe	1	1	
D28	HF956G8001	Oil feeding pipe	1	1	
D29	HF924E8001	Bushing	1	1	
D30	HF923E8001	Collar	2	2	
D31	HE60E48001	Adjusting shaft	1	1	
D32	H431050050	Screw	2	2	M5×5
D34	HF928E8001	Ball pin	1	1	
D35	H415050120	Screw	1	1	M5×12
D36	HE60E78001	Lever	1	1	
D37	H415060200	Screw	1	1	M6×20
D56	HF962E7101	Shaft	1	1	
D57	H415040120	Screw	1	1	M4×12
D58	HF924E8001	Bushing	2	2	
D59	H402050080	Screw	2	2	M5×8
D60	HF923E8001	Collar	2	2	
D62	HF964E8001	Oil wick	1	1	

D.PRESSER FOOT MECHANISM

Fig. No.	Part No.	Description	GC20688-DC	GC20688-BDC	Remarks
D63	H415030060	Screw	1	1	M3×6
D64	HF974E8001	Plate	1	1	
D65	HF973E8001	Oil satchel	1	1	
D66	HF972E8001	Draught rod	1	1	
D67	HF961E8001	Plug	1	1	
D68	HF983E8001	Oil pipe	1	1	
D69	HF984E8001	Oil wick	1	1	
D70	HF982E8001	Spring	1	1	
D71	HF986E8001	Oil wick	1	1	
D72	HF977E8001	Pin	1	1	
D73	H401040040	Screw	1	1	M4×4
D74	HF977E8001	Pin	1	1	
D75	HF978E8001	Oil wick	1	1	
D76	HF979E8001	Stopper claw	1	1	
D77	HF925F8001	Joint	1	1	
D78	HF926F8001	Pin	1	1	
D79	HF933F8001	Slide block	1	1	
D80	HF914B8001	Screw	2	2	
D81	HF934F8001	Guide	1	1	
D82	HF928F8001	Pin	1	1	
D83	HF930F8001	Oil wick	1	1	
D84	HF932F8001	Screw	1	1	
D85	HF979E8001	Stopper claw	1	1	
D86	HF939F8001	Oil wick	1	1	
D87	H431050100	Screw	1	1	M5×10
D88	HF940F8001	Bushing	1	1	
D89	HF938F8001	Outer presser bar	1	1	
D90	HF946F8001	Presser connecting plate	1	1	
D91	HF977E8001	Connecting pin	2	2	
D92	HF978E8001	Oil wick	2	2	
D93	HF979E8001	Stopper claw	2	2	
D94	H401040040	Screw	1	1	M4×4
D95	HF956F8001	Inner presser bar	1	1	
D96	HE61F28001	Inner presser foot	1	1	8mm
D96	HE61F68001	Inner presser foot	1	1	3mm
D97	HF960F8001	Screw	1	1	
D98	HE60F88001	Outer presser foot	1	1	8mm
D98	HE61F68001	Outer presser foot	1	1	3mm
D99	HF944F8001	Screw	1	1	M4×10

E. UPPER FEED LIFTING ROCK SHAFT MECHANISM

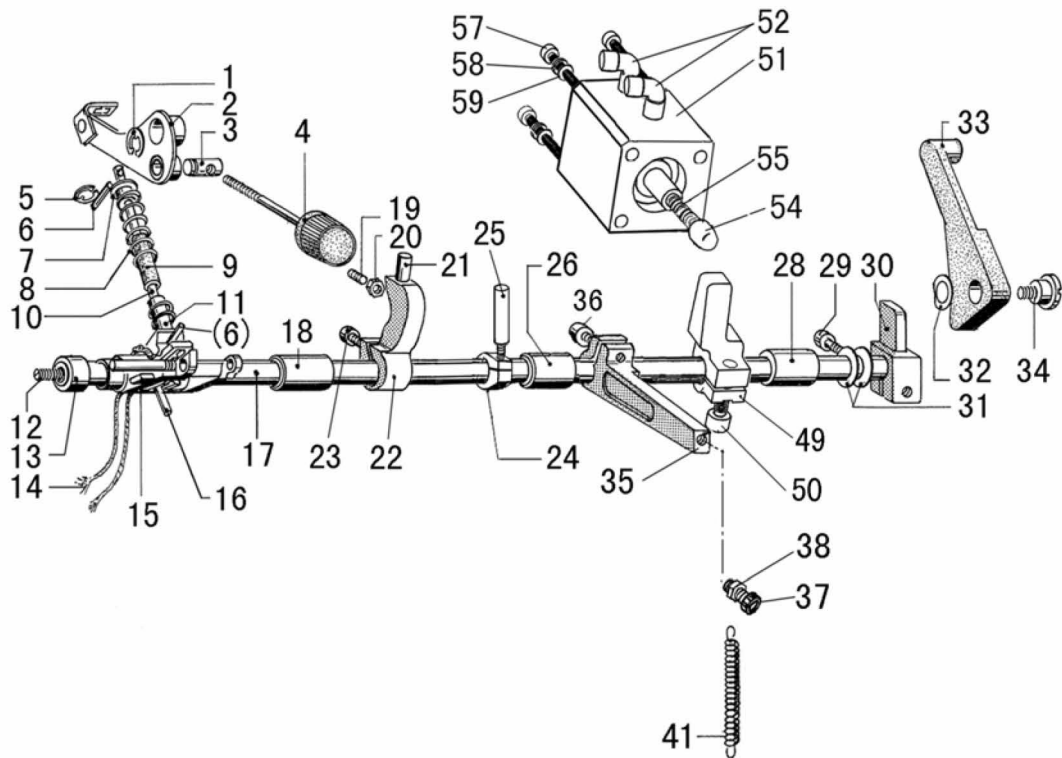

E.UPPER FEED LIFTING ROCK SHAFT MECHANISM

Fig. No.	Part No.	Description	GC20688-DC	GC20688-BDC	Remarks
E01	H007013080	E-type retaining ring 8	1	1	
E02	HF965F7101	Press adjusting plate assy	1	1	
E03	HF963F8001	Pin	1	1	
E04	HF961F7101	Press adjusting dial	1	1	
E05	H007013050	E-type retaining ring 5	1	1	
E06	H609030080	Spring pin	2	2	
E07	HF976F8001	Spring support (U)	1	1	
E08	HF972F8001	Spring	1	1	
E09	HF975F8001	Hose	1	1	
E10	HF973F8001	Shaft	1	1	
E11	HF974F8001	Spring support (D)	1	1	
E12	H428080120	Bolt	1	1	M8×12
E13	HF905F8001	Press-foot lifter shaft bush(L)	1	1	
E14	HF922F8001	Oil wick	1	1	
E15	HF919F7101	Press-foot lifter connection assy	1	1	
E16	H605050320	Pin	1	1	
E17	HF904F8001	Press bar lifter shaft	1	1	
E18	HF906F8001	Spreader shaft bush(L2)	1	1	
E19	H424050160	Set screw	1	1	
E20	H003002050	Nut	1	1	
E21	HF997F8001	Stopper	1	1	
E22	HE61F88001	Crack	1	1	
E23	H415060160	Screw	1	1	M6×16
E24	HE60F58001	Set screw collar	1	1	
E25	HE60F68001	Screw	1	1	
E26	HF908F8001	Bushing(R2)	1	1	
E28	HF907F8001	Bushing(R)	1	1	
E29	H415060200	Screw	1	1	M6×20
E30	HF913F8001	Crack	1	1	
E31	HF915F8001	Washer	2	2	
E32	H005014080	Wave washer	1	1	
E33	HF916F8001	Lifter lever	1	1	
E34	HF917F8001	Screw	1	1	
E35	HF980F8001	Lever(U)	1	1	
E36	H415060160	Screw	1	1	M6×16
E37	H415050180	Screw	1	1	M5×18
E38	H003002050	Nut	1	1	M5
E41	HF982F8001	Main spring	1	1	
E49	HF901F8001	Crack	1	1	
E50	H415060160	Screw	1	1	
E51	HF911F8001	Pump	1	1	SDA32×30
E52	HF912M8001	Windpipe joint	2	2	EPL4-01 φ4-1/8"
E54	HF91BF8001	Coupling	1	1	

E.UPPER FEED LIFTING ROCK SHAFT MECHANISM

Fig. No.	Part No.	Description	GC20688-DC	GC20688-BDC	Remarks
E55	H428060160	Screw	1	1	
E57	H415040550	Screw	4	4	
E58	H005008040	Spring washer	4	4	
E59	H005004040	Washer	4	4	

F. STITCH REGULATOR MECHANISM

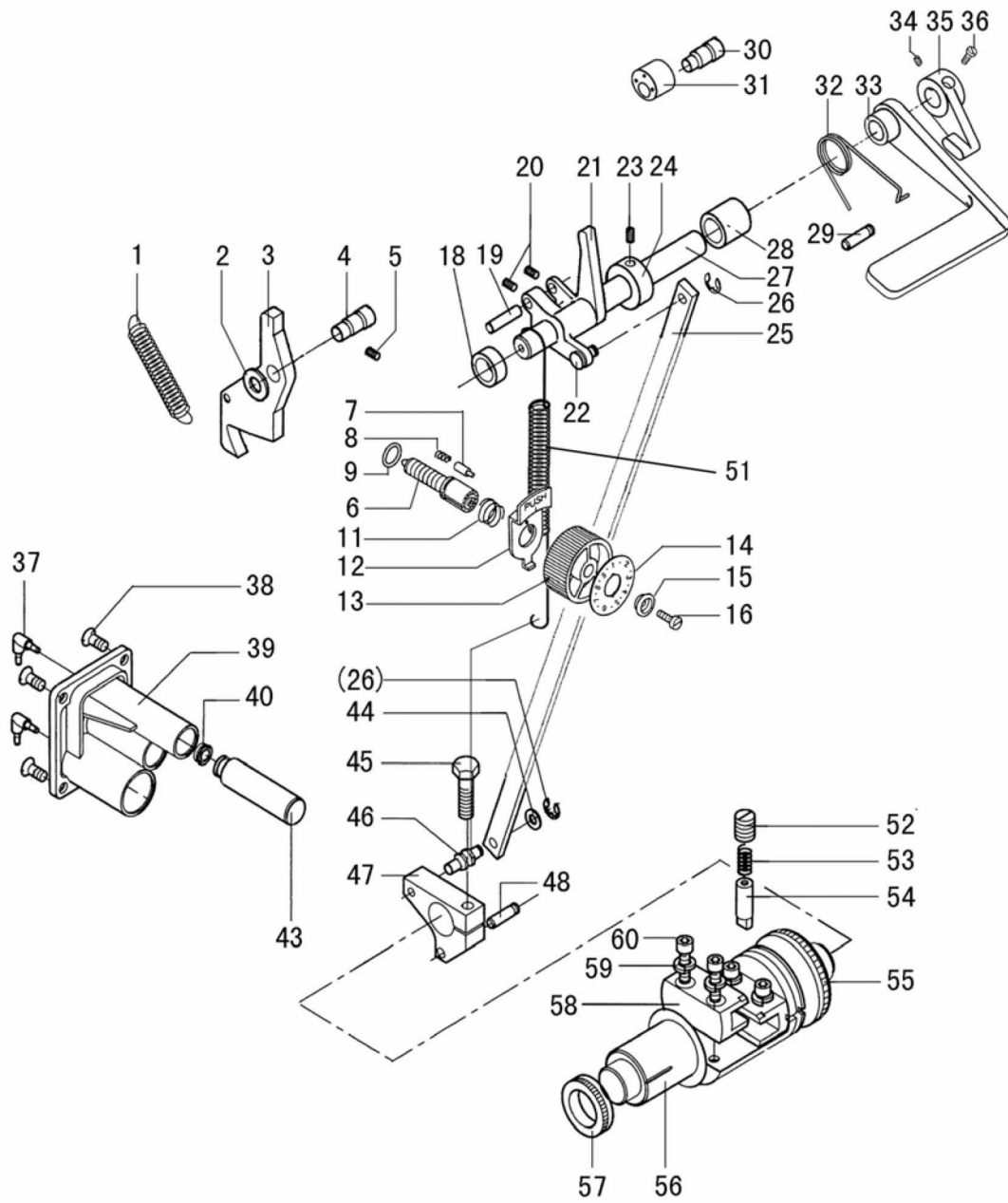

F.STITCH REGULATOR MECHANISM

Fig. No.	Part No.	Description	GC20688-DC	GC20688-BDC	Remarks
F01	HF925H8001	Spring	1	1	
F02	HF924H8001	Washer	1	1	
F03	HF922H8001	Feed adjusting arm	1	1	
F04	HF923H8001	Pin	1	1	
F05	H431050080	Bolt	1	1	M5×8
F06	HF914H8001	Feed adjusting screw (long)	1	1	
F07	HA700F2030	Positioning pin	1	1	
F08	H3200F2110	Spring	1	1	
F09	HA109F0674	O ring	1	1	
F11	HA720F0687	Spring	1	1	
F12	HA720F0683	Support plate	1	1	
F13	HA7421F120	Feed adjusting dial	1	1	
F14	HF909H8001	Feed adjusting dial plate(L)	1	1	
F15	HA720F0685	Bushing	1	1	
F16	HA720F0686	Screw	1	1	
F18	HF928H8001	Reverse shaft bushing(L)	1	1	
F19	HF932H8001	Pin	1	1	
F20	H428060080	Bolt	2	2	M6×8
F21	HF930H8001	Reverse stitching arm(U)	1	1	
F22	HF934H8001	Pin	1	1	
F23	H428060060	Bolt	1	1	M6×6
F24	HF927H8001	Collar	1	1	
F25	HF933H8001	Rod	1	1	
F26	H007013050	E-tpye retaining ring 5	2	2	
F27	HF970H8001	Reverse stitching shaft	1	1	
F28	HF931H8001	Reverse shaft bushing(R)	1	1	
F29	H6511H8001	Pin	1	1	
F30	H4937L8001	Bolt	1	1	
F31	H4938L8001	Rubber ring	1	1	
F32	HF969H8001	Spring	1	1	
F33	HF968H8001	Reverse stitching lever	1	1	
F34	HA3411D308	Bolt	1	1	
F35	H4936L8001	Reverse stitching lever block	1	1	
F36	HA113F0684	Bolt	1	1	
F37	HF937E8001	Coupling	1	1	
F38	H403060120	Screw	4	4	M6×12
F39	HF947H8001	Pump	1	1	
F40	HF954H8001	Ring	1	1	
F43	HF953H8001	Piston	1	1	
F44	H005001060	Washer	1	1	
F45	H104060250	Screw(D)	1	1	M6×25
F46	HF939H8001	Bolt	1	1	
F47	HF937H8001	Reverse stitching arm(D)	1	1	

F.STITCH REGULATOR MECHANISM

Fig. No.	Part No.	Description	GC20688-DC	GC20688-BDC	Remarks
F48	HF941H8001		1	1	
F51	HF973H8001	Pull spring	1	1	
F52	H424100100	Thread pin	1	1	M10×10
F53	H3100D2090	Presser spring	1	1	
F54	HF963H8001	Key	1	1	
F55	HF966H8001	Oil seal	1	1	
F56	HF958H8001	Shaft	1	1	
F57	HF967H8001	Oil seal	1	1	
F58	HF961H8001	Guide	2	2	
F59	H005009050	Elastic washer	4	4	
F60	H415050160	Screw	4	4	M5×16
F61	HF974H8001	Pothead	1	1	

G. FEEDING AND FEED LIFTING & HOOK SHAFT MECHANISM

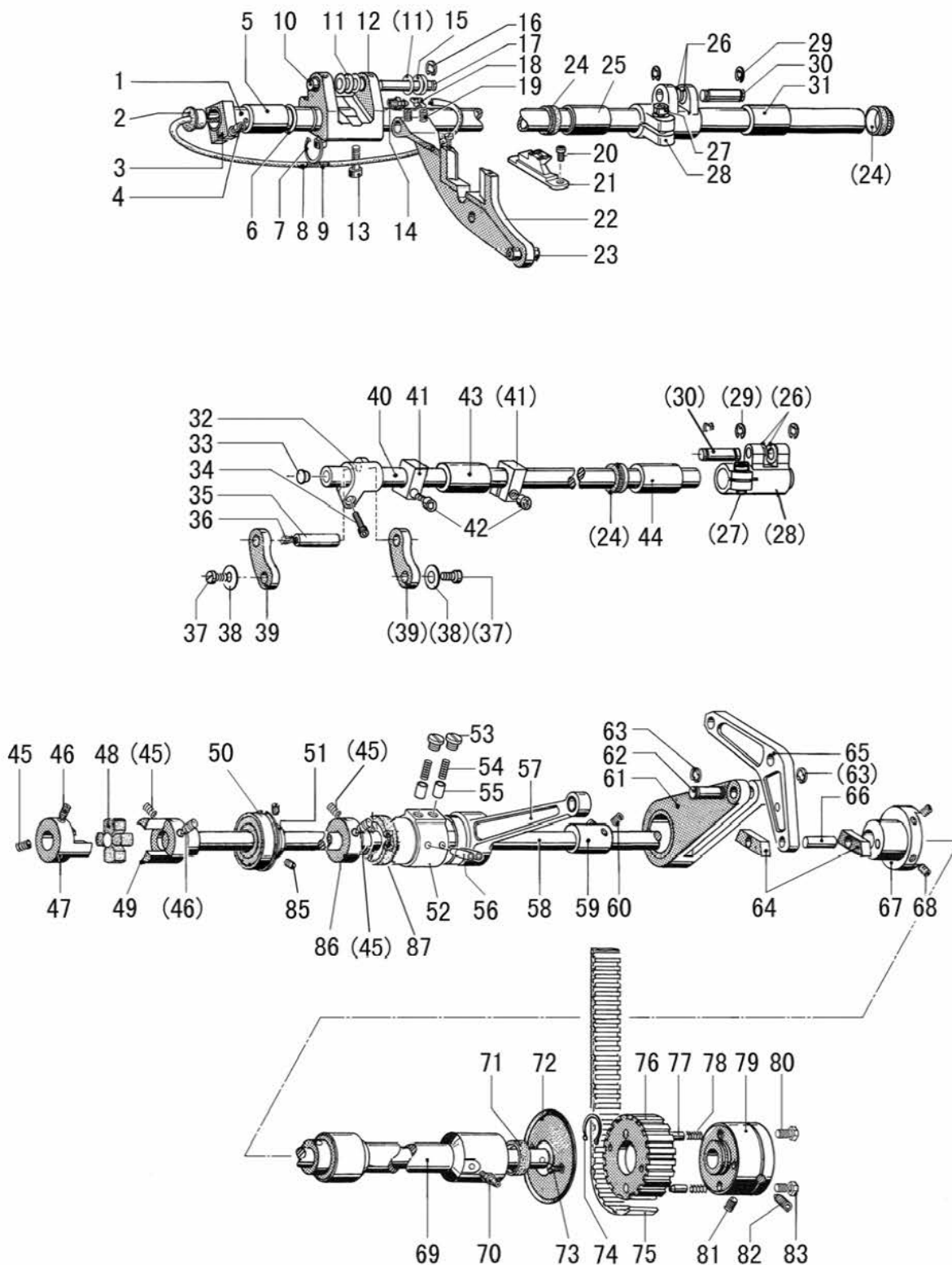

G.FEEDING AND FEED LIFTING & HOOK SHAFT MECHANISM

Fig. No.	Part No.	Description	GC20688-DC	GC20688-BDC	Remarks
G01	HF928I8001	Feed shaft	1	1	
G02	HF959G8001	Rubber cap	1	1	
G03	HF965G8001	Adjusting shaft collar	1	1	
G04	H415040120	Bolt	1	1	M4×12
G05	HF927E8001	Bushing(L)	1	1	
G06	HF931I8001	Thurst ring	1	1	
G07	HF930I8001	C-type retaining ring	1	1	
G08	HF941I8001	Tube	1	1	
G09	HF942I8001	Oil wick	1	1	
G10	HF937I8001	Bushing	4	4	
G11	HF945I8001	Washer	3	3	
G12	HF935I8001	Feed arm(L)	1	1	
G13	HF936I8001	Bolt(L)	2	2	
G14	HF956G8001	Oil joint	1	1	
G15	HF946I8001	Spring	2	2	
G16	H007013050	E-type retaining ring 5	1	1	
G17	HF944I8001	Pin	1	1	
G18	HF939I8001	Tube support	1	1	
G19	HF948I8001	Bolt	2	2	
G20	HF951I8001	Screw	2	2	
G21	HE60I68001	Feed dog	1	1	8mm
G21	HE61I18001	Feed dog	1	1	3mm
G22	HF949I8001	Feed bracket	1	1	
G23	HF953I8001	Pin	1	1	
G24	HF929I8001	Oil seal	3	3	
G25	HF924E8001	Feed shaft bushing(L)	1	1	
G26	HF927I8001	Washer	4	4	
G27	H415060120	Bolt(R)	2	2	M6×12
G28	HF923I8001	Feed shaft arm(R)	2	2	
G29	H007013050	E-type retaining ring 5	4	4	
G30	HF926I8001	Pin	2	2	
G31	HF924E8001	Feed shaft bushing(R)	2	2	
G32	HF957I8001	Feed connecting arm(L)	1	1	
G33	HA719B0707	Rubber cap	1	1	
G34	H415050160	Bolt	1	1	M5×16
G35	HF958I8001	Pin(L)	1	1	
G36	HF961I8001	Oil wick	1	1	
G37	H401030080	Bolt	2	2	
G38	HF954I8001	Washer	2	2	
G39	HF952I8001	Feed link	2	2	
G40	HF959I8001	Shaft	1	1	
G41	HF965G8001	Adjusting shaft collar	2	2	
G42	H415040120	Bolt	2	2	M4×12

G.FEEDING AND FEED LIFTING & HOOK SHAFT MECHANISM

Fig. No.	Part No.	Description	GC20688-DC	GC20688-BDC	Remarks
G43	HF927E8001	Bushing(L)	1	1	
G44	HF90E18001	Bushing(R)	1	1	
G45	H428060100	Bolt	2	2	M6 × 10
G46	H429060100	Bolt	2	2	M6 × 10
G47	HF975J8001	Coupling claw(L)	1	1	
G48	HF978J8001	Toothed wreath	1	1	
G49	HF977J8001	Coupling craw(R)	1	1	
G50	HC01118026	O ring	1	1	
G51	HF988I8001	Oil seal	1	1	
G52	HF987I8001	Bushing(L)	1	1	
G53	HF992I8001	Bolt	1	1	
G54	H34412C110	Plunger spring	2	2	
G55	HF966I8001	Plunger	2	2	
G56	HA110E0672	Oil feeding pipe	2	2	
G57	HF971I7101	Feed rod	1	1	
G58	HF905I8001	Lower shaft	1	1	
G59	HF963I8001	Feed cam	1	1	
G60	H428060050	Bolt	2	2	M6 × 5
G61	HF919I7101	Lowe feed connecting rod assy	1	1	
G62	HF926I8001	Pin	1	1	
G63	H007013050	E-tpye retaining ring 5	2	2	
G64	HF961H8001	Slide block	2	2	
G65	HF925I8001	Back sylinder connection	1	1	
G66	HF960H8001	Pin	1	1	
G67	HF917I8001	Lower feed cam	1	1	
G68	H428060080	Bolt	2	2	M6 × 8
G69	HF990I8001	Bushing(R)	1	1	
G70	HF956G8001	Oil joint	1	1	
G71	HF991I8001	Sealing ring	1	1	
G72	HF915I8001	Disk	1	1	
G73	HF916I8001	Stunk screw	2	2	
G74	H007009220	Retainer ring	1	1	
G75	HF907I8001	Toothed belt	1	1	
G76	HF908I8001	Belt pulley(D)	1	1	
G77	HF911I8001	Piston	2	2	
G78	H3404D0658	Presser spring	2	2	
G79	HF910I8001	Body	1	1	
G80	H431060120	Adjusting screw	2	2	M6 × 12
G81	H431080120	Bolt	1	1	M8 × 12
G82	H430080120	Bolt	1	1	M8 × 12
G83	H003002060	Nut	2	2	M6

H. HOOK SADDLE MECHANISM

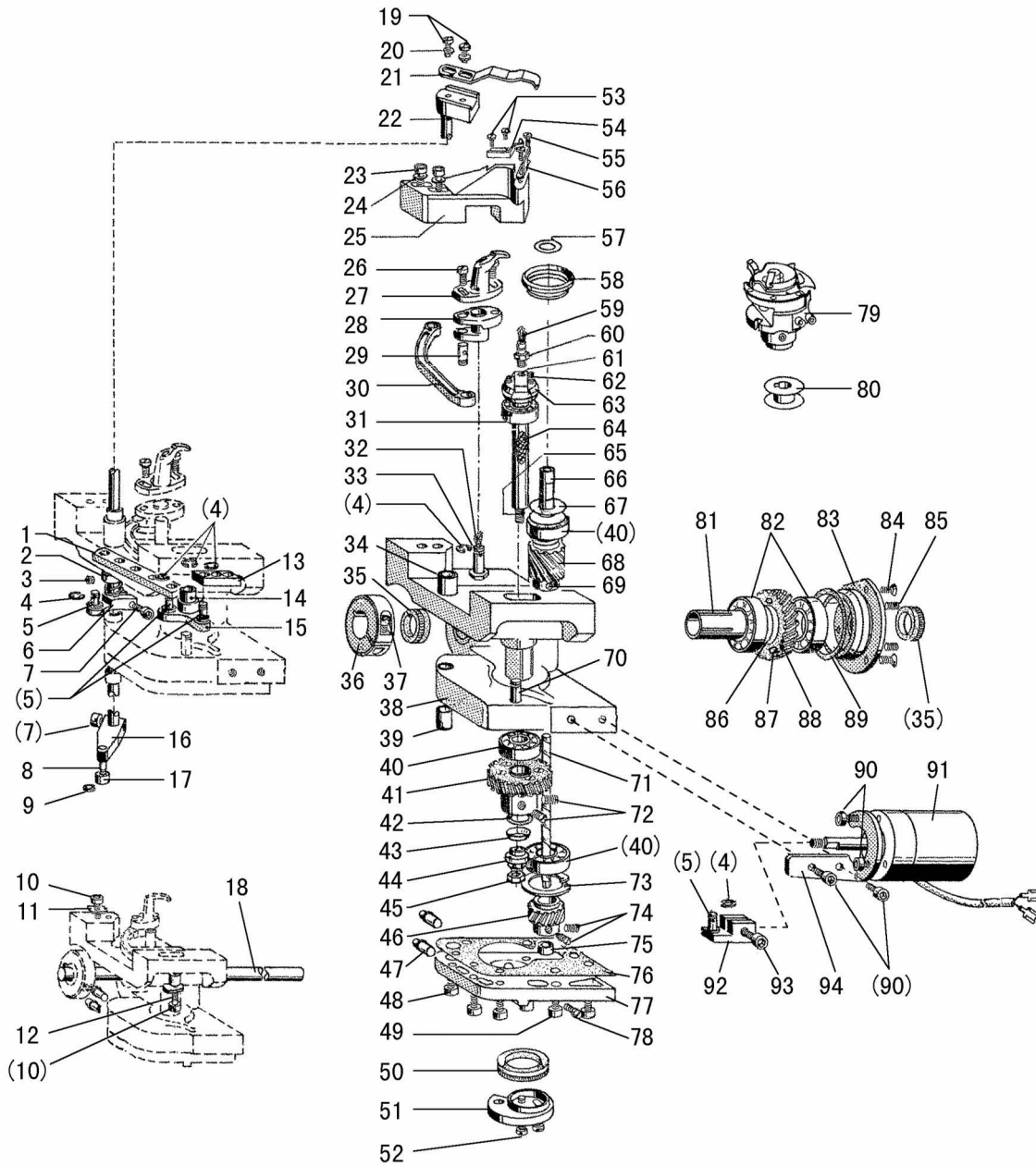

H.HOOK SADDLE MECHANISM

Fig. No.	Part No.	Description	GC20688-DC	GC20688-BDC	Remarks
H01	HG013J8001	Link lever	1	1	
H02	HF920J8001	collar	1	1	
H03	H428050050	Bolt	1	1	M5×5
H04	H007013040	E-type stop ring 4	6	6	
H05	HF934J8001	Pin	4	4	
H06	HG012J8001	Thread trimmer arm(S)	1	1	
H07	H415040120	Bolt	2	2	M4×12
H08	HF939J8001	Pin	1	1	
H09	H007013030	E-type stop ring 4	1	1	
H10	H415060220	Bolt	2	2	M6×22
H11	HF92BJ8001	Spacer	1	1	
H12	HF92CJ8001	Eccentric collar	1	1	
H13	HG017J8001	Driving knife connection	1	1	
H14	HF919J8001	Bushing	1	1	
H15	HG016J8001	Crack	1	1	
H16	HF937J8001	Thread trimmer arm(L)	1	1	
H17	HF940J8001	Roller	1	1	
H18	HG021J8001	Driving shaft mandril	1	1	
H19	H415030060	Bolt	2	2	M3×6
H20	H005004030	Washer	2	2	
H21	HF914J8001	Driving knife	1		
H21	HE40J88001	Driving knife		1	
H22	HF913J8001	Driving knife shaft	1	1	
H23	H415050250	Bolt	2	2	M5×25
H24	H005005050	Washer	2	2	
H25	HF905J8001	Fixed knife support bracket	1		
H25	HE40J68001	Fixed knife support bracket		1	
H26	HF90HJ8001	Screw	2	2	
H27	HF90GJ8001	Opener	1		
H27	HE41J28001	Opener		1	
H28	HF90FJ8001	Opener setting bracket	1		
H28	HE41J18001	Opener setting bracket		1	
H29	HF90EJ8001	Pin	1	1	
H30	HF90DJ8001	Opener shaft	1	1	
H31	HF996J8001	Bearing	1	1	
H32	HG008J8001	Oil wick	1	1	
H33	HG007J8001	Oil joint	1	1	
H34	HF917J8001	Bushing	1	1	
H35	HF964J8001	Oil seal	2	2	
H36	HF973J8001	Collar	1	1	
H37	H415060200	Bolt	1	1	M6×20
H38	HG006J8001	Horizontal hook base	1	1	
H39	HF919J8001	Bushing	1	1	

H.HOOK SADDLE MECHANISM

Fig. No.	Part No.	Description	GC20688-DC	GC20688-BDC	Remarks
H40	HF984J8001	Bearing	3	3	
H41	HF91CJ7101	Gear base assy	1	1	
H42	HC01095018	Wave washer	1	1	
H43	H005014060	Belleville spring washer	1	1	
H44	HF91IJ8001	Adjusting block	1	1	
H45	HF91JJ8001	Hexagonal nut	1	1	
H46	HF91AJ8001	Driving gear	1	1	
H47	HF947J8001	Oil joint(M)	2	2	
H48	H415040080	Bolt(short)	6	6	M4×8
H49	H415040120	Bolt(long)	3	3	M4×12
H50	HF958J8001	Oil seal	1	1	
H51	HF942J8001	Thread trimmer cam	1	1	
H52	H415040080	Bolt	3	3	M4×8
H53	H402025060	Screw	2	2	M2. 5×6
H54	HF910J8001	Thread holding spring	1	1	
H55	H402025060	Screw	2	2	M2. 5×6
H56	HF908J8001	Fixed knife	1	1	
H57	HF989J8001	Uncork washer	5	5	
H58	HF991J8001	Hook support	1	1	
H59	HF90AJ8001	Oil wick	1	1	
H60	HF999J8001	Adjusting pin	1	1	
H61	HF90BJ8001	Adjusting guide rail	1	1	
H62	HF997J8001	Bolt	2	2	
H63	HF995J8001	Shaft	1	1	
H64	HF92AJ8001	Oil wick	1	1	
H65	H424050300	Bolt	1	1	M5×30
H66	HF992J8001	Spacer	1	1	
H67	HF981J8001	Hook shaft	1	1	
H68	HF983J8001	Driven gear	1	1	
H69	H431050050	Bolt	2	2	M5×5
H70	HG014J8001	Arm adjusting pin	1	1	
H71	HF990J8001	Lubrication shaft	1	1	
H72	H415050060	Bolt	2	2	M5×6
H73	H007007260	Retainer ring	1	1	
H74	H431050050	Bolt	2	2	M5×5
H75	HF956J8001	Bushing	1	1	
H76	HF954J8001	Sheet pack	1	1	
H77	HG010J8001	Cover(L)	1	1	
H78	H402030040	Bolt	1	1	M3×4
H79	HF985J7101	Horizontal hook assy	1		
H79	HE41J07101	Horizontal hook assy		1	
H80	HF971B8001	Bobbin	1		
H80	HE41J38001	Bobbin		1	

H.HOOK SADDLE MECHANISM

Fig. No.	Part No.	Description	GC20688-DC	GC20688-BDC	Remarks
H81	HF967J8001	Driving shaft	1	1	
H82	HF963J8001	Boll bushing	2	2	
H83	HF962J8001	Lower shaft holder	1	1	
H84	HF965J8001	Screw	3	3	
H85	HF966J8001	Bolt	3	3	
H86	HF970J8001	Washer	1	1	
H87	HF969J8001	Driving gear	1	1	
H88	H403030080	Screw	4	4	
H89	HC01387018	O-ring	1	1	
H90	H415040100	Bolt	4	4	M4×10
H91	HG025J8001	Thread trimmer solenoid	1	1	
H92	HG019J8001	Solenoid setting bracket	1	1	
H93	H415040080	Bolt	1	1	M4×8
H94	HG020J8001	Solenoid setting plate	1	1	

I. OIL LUBRICATION MECHANISM

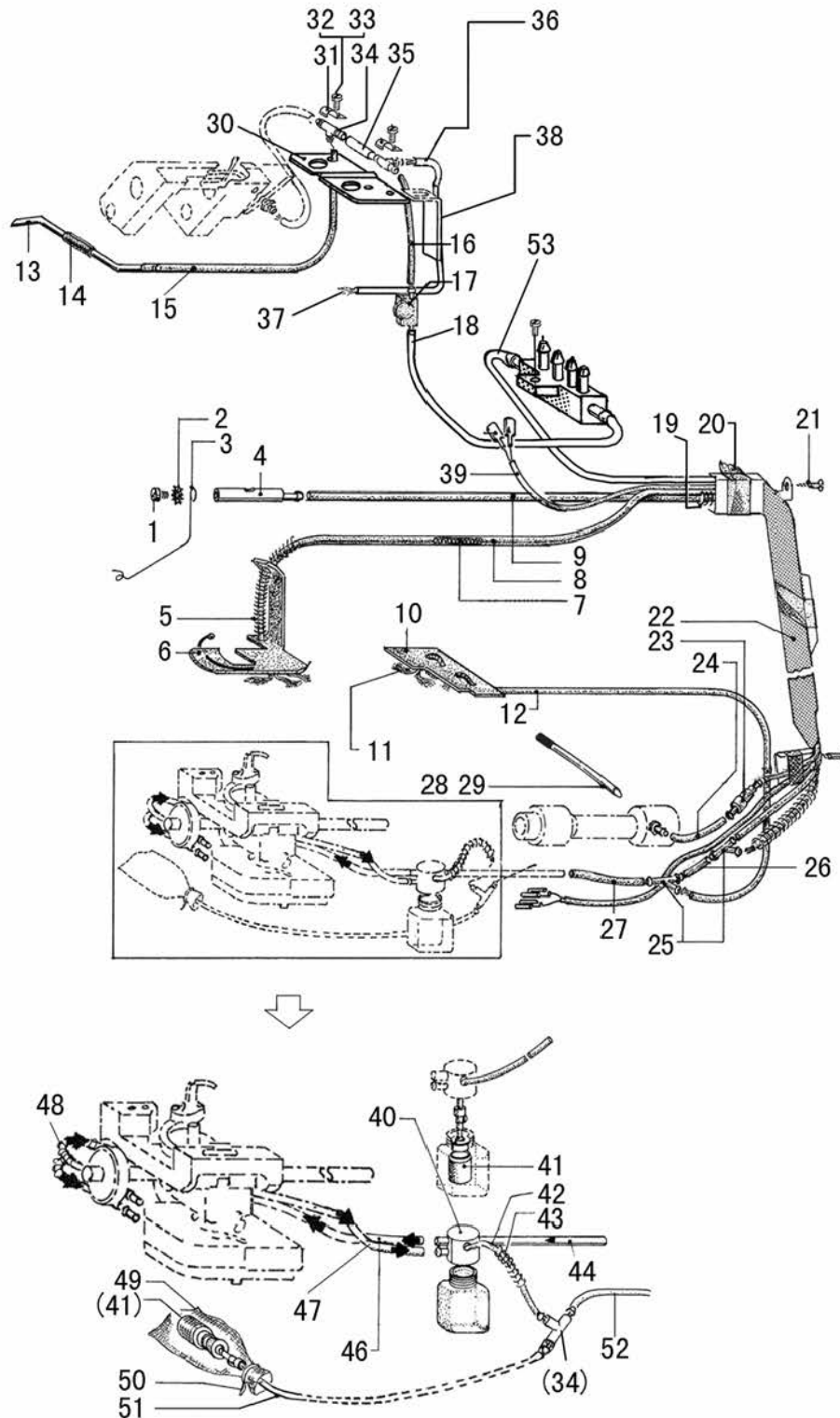

I.OIL LUBRICATION MECHANISM

Fig. No.	Part No.	Description	GC20688-DC	GC20688-BDC	Remarks
I01	H401050080	Bolt	1	1	M5×8
I02	H005018050	Spacer	1	1	
I03	HF909K8001	Oil wick support	1	1	
I04	HF917K8001	Oil joint	1	1	
I05	HF908K8001	Tube guide	1	1	
I06	HF906K8001	Felt	1	1	
I07	HF907K8001	Oil wick	1	1	φ 4×850
I08	HF905K8001	Oil tube	1	1	φ 7× φ 5×740
I09	HF918K8001	Oil tube	1	1	φ 7× φ 5×600
I10	HF914K8001	Felt	1	1	
I11	HF915K8001	Oil wick	1	1	φ 4×680
I12	HF913K8001	Oil tube	1	1	φ 7× φ 5×580
I13	HF948K8001	Pipe	1	1	
I14	HF950K8001	Oil tube	1	1	φ 3× φ 5×25
I15	HF949K8001	Hose	1	1	φ 3× φ 5×210
I16	HF936K8001	Oil pipe	1	1	φ 3× φ 5×60
I17	HF959K8001	Oil window	1	1	
I18	HE60K78001	Oil pipe	1	1	φ 3× φ 5×150
I19	HF919K8001	Spring	1	1	
I20	HF962K8001	Tape	1	1	
I21	HA04042160	Screw	2	2	
I22	HF960K8001	Guard plate	1	1	
I23	HF956K7101	Valve	1	1	
I24	HF955K8001	Main oil pipe	1	1	φ 3× φ 5×110
I25	HF920K8001	Oil joint	2	2	
I26	HF921K8001	Oil pipe	1	1	φ 7× φ 5×25
I27	HF922K8001	Oil pipe	1	1	φ 7× φ 5×120
I28	HF938K8001	Oil joint	1	1	
I29	HF939K8001	Oil pipe	1	1	φ 7× φ 5×140
I30	HF951K8001	Oil pipe setting plate	1	1	
I31	H3200K0170	Oil wick setting plate	2	2	
I32	H415040100	Screw	2	2	M4×10
I33	H005001040	Washer	2	2	
I34	H3210K0671	T-joint	3	3	
I35	HF942K8001	Hose	1	1	φ 3× φ 5×21
I36	HF947K8001	Hose	1	1	φ 3× φ 5×30
I37	HF946K8001	Oil wick	1	1	φ 3× φ 5×30
I38	HF943K8001	Oil pipe plate assy	1	1	
I39	HF92FJ7101	Wire assy	1	1	
I40	HF927K7101	Oil hose assy	1	1	
I41	HF963K7101	Filter pot assy	2	2	
I42	HF929K8001	Oil pipe	1	1	φ 3× φ 5×150
I43	HF930K8001	Support spring	1	1	

I.OIL LUBRICATION MECHANISM

Fig. No.	Part No.	Description	GC20688-DC	GC20688-BDC	Remarks
I44	HF923K8001	Oil pipe	1	1	
I46	HE60K48001	Oil pipe	1	1	$\phi 7 \times \phi 5 \times 100$
I47	HE60K58001	Oil pipe	1	1	$\phi 7 \times \phi 5 \times 110$
I48	HF926K8001	Support spring	2	2	
I49	HF932K8001	Felt part	1	1	
I50	HA300I2040	Cable tie	1	1	
I51	HF934K8001	Oil pipe	1	1	$\phi 3 \times \phi 5 \times 250$
I52	HF937K8001	Oil pipe	1	1	$\phi 3 \times \phi 5 \times 600$
I53	HE60K88001	Oil pipe	1	1	$\phi 3 \times \phi 5 \times 600$

J. ACCESSORIES

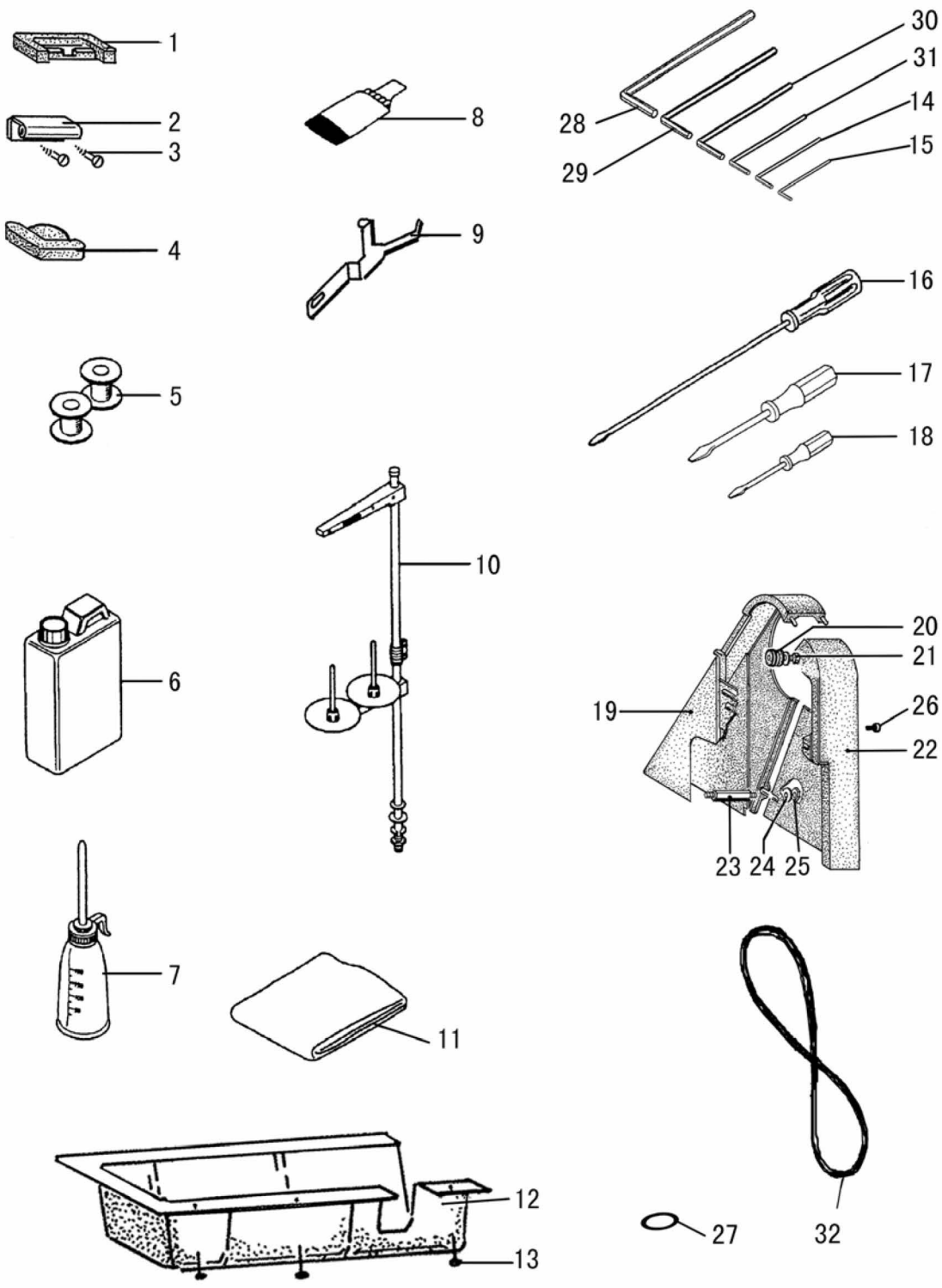

J.ACCESSORIES

Fig. No.	Part No.	Description	GC20688-DC	GC20688-BDC	Remarks
J01	HA307J0671	Hinge support	2	2	
J02	HF914L8001	Hinge	2	2	
J03	H411060100	Screw	4	4	
J04	HF905L8001	Head cushion	2	2	
J05	HF971B8001	Bobbin	2		
J05	HE41J38001	Bobbin		2	
J06	HA100J2170	Oil tank	1	1	
J07	H200400069	Oiler	1	1	
J08	HF904B7101	Neddle	4	4	
J09	HF913L8001	Detector setting plate	1	1	
J10	HA200J2030	Cotton stand assy	1	1	
J11	HA100J2180	Cover	1	1	
J12	HF904L8001	Oil plate	1	1	
J13	16250	Nail	10	10	
J14	HB01001025	Hexagonal wrench (2.5)	1	1	
J15	HB01001015	Hexagonal wrench (1.5)	1	1	
J16	HA300J2070	Screw driver(L)	1	1	
J17	HA300J2200	Screw driver(M)	1	1	
J18	HA300J2210	Screw driver(S)	1	1	
J19	HF908L8001	Belt guard(R)	1	1	
J20	HF915L8001	Rubber washer	1	1	
J21	H401060120	Bolt	1	1	
J22	HF907L8001	Belt guard(L)	1	1	
J23	HF911L8001	Bolt	1	1	
J24	H005001060	Washer	1	1	
J25	H7316E8001	Nut	1	1	
J26	H409060080	Screw	1	1	
J27	H7331D8001	Rubber ring	3	3	
J28	HB01001060	Hexagonal wrench (6)	1	1	
J29	HB01001050	Hexagonal wrench (5)	1	1	
J30	HB01001040	Hexagonal wrench (4)	1	1	
J31	HB01001030	Hexagonal wrench (3)	1	1	

K. PNEUMATIC CONTROL MECHANISM

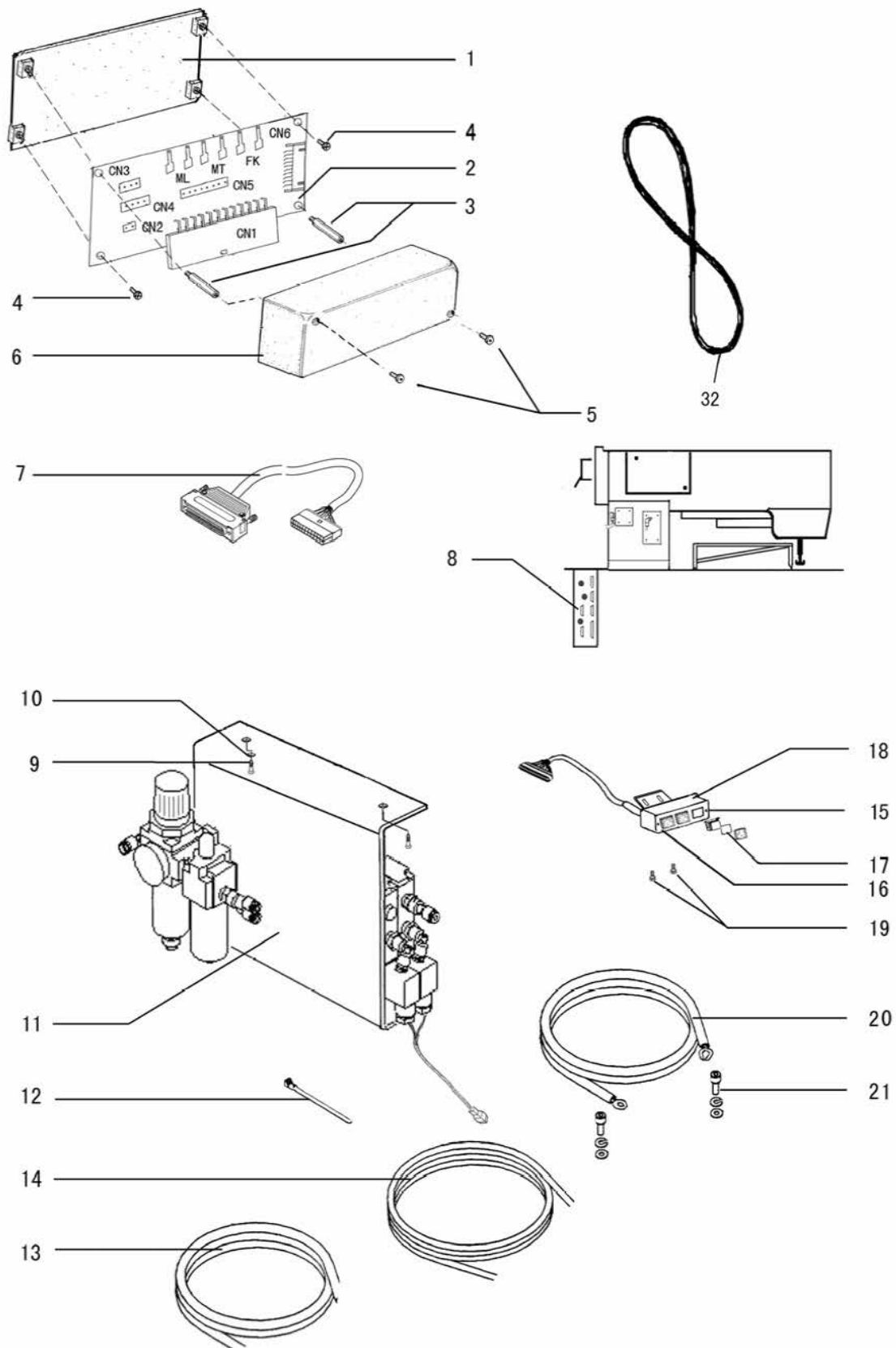

K.PNEUMATIC CONTROL MECHANISM

Fig. No.	Part No.	Description	GC20688-DC	GC20688-BDC	Remarks
K01	HF930M8001	connecting box base	1	1	
K02	HF924M8001	PCB board	1	1	
K03	HF932M8001	connecting box screw	2	3	
K04	H409040160	screw	2	3	
K05	H415030120	screw	2	3	
K06	HF931M8001	connecting box cover	1	2	
K07	HF925M7101	control box wire assy	1	1	CN1
K09	H801045200	screw	2	2	
K10	HA300J2230	washer	4	4	
K11	HE60M47101	pneumatic assy	1	1	
K12	HA300I2040	nylon fixer	1	1	
K13	HF958M8001	windpipe	2	2	300mm ϕ 6
K14	HF914M8001	windpipe	3	3	800mm ϕ 4
K15	H409040060	screw	2	2	
K16	HE60M77101	button wires connecting assy	1	1	
K17	HE64M77101	plotting	4	4	
K18	HE60M68001	button set frame	1	1	
K19	H415040080	screw	2	2	
K20	HF943M7101	grounding assy	1	1	
K21	HZ11040100	screw assy	2	2	

L. KNIFFE MECHANISM

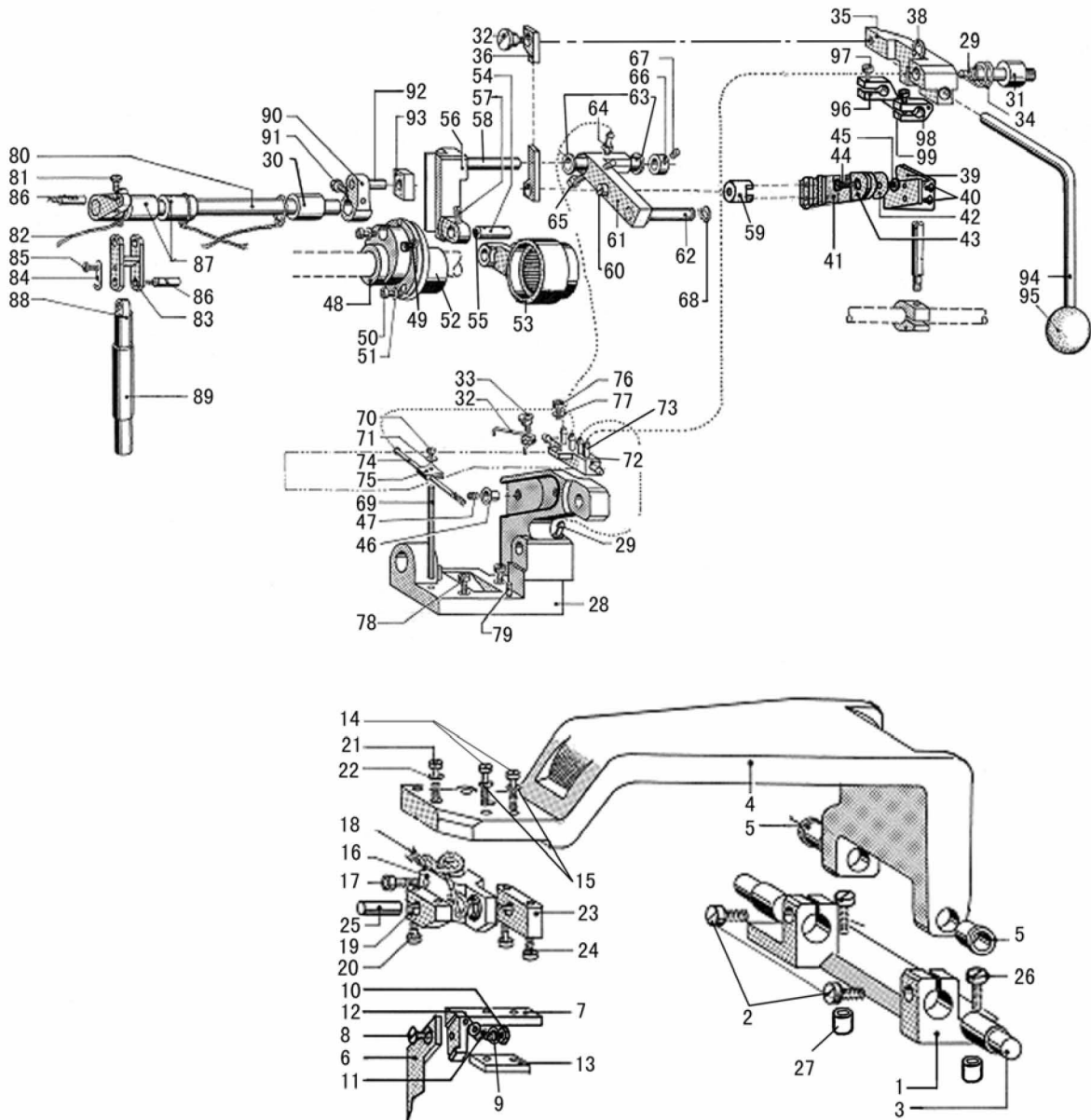

L.KNIFFE MECHANISM

Fig. No.	Part No.	Description	GC20688-DC	GC20688-BDC	Remarks
L01	HE60N68001	pedestal	1	1	
L02	H415040160	screw	2	2	M4×16
L03	HE60N78001	shaft	2	2	
L04	HE60N98001	Setting bracket	1	1	
L05	HE61N08001	bushing	2	2	
L06	HE61N18001	knife	1	1	8mm
L06	HE69N38001	knife	1	1	3mm
L07	HE61N28001	bracket	1	1	
L08	H411040100	screw	1	1	M4×10
L09	H005001040	washer	1	1	4
L10	H003002040	nut	1	1	4
L11	H415030060	screw	1	1	M3×6
L12	H005001030	washer	1	1	3
L13	HE61N38001	connecting block	1	1	
L14	H415040200	screw	2	2	M4×20
L15	H005001040	washer	2	2	4
L16	HE61N47101	bearing complete	1	1	
L17	H415050160	screw	1	1	M5×16
L18	HE61N78001	oil wick	1	1	
L19	HE61N88001	supporting block	1	1	
L20	H415040250	screw	1	1	M4×25
L21	H415030140	screw	1	1	M3×14
L22	H005001030	washer	1	1	3
L23	HE61N98001	supporting block	1	1	
L24	H415040250	screw	2	2	M4×25
L25	HE62N08001	shaft	1	1	
L26	H415050180	screw	2	2	M5×18
L27	HE62N18001	washer	2	2	
L28	HE62N48001	setting platform	1	1	
L29	HE62N58001	oil nozzle	2	2	
L30	HE62N68001	bushing	1	1	
L31	HE62N78001	shaft	1	1	
L32	HE62N88001	spring	1	1	
L33	HE62N98001	screw	1	1	
L34	HE63N08001	spring	1	1	
L35	HE63N28001	crank	1	1	
L36	HE63N38001	link	1	1	
L37	HE62N98001	screw	1	1	
L38	H007013070	Retaining ring	1	1	7
L39	HE63N58001	spring hook	1	1	
L40	H403030060	screw	2	2	M3×6
L41	HE63N67101	board complete	1	1	
L42	HE64N08001	washer	1	1	

L.KNIFFE MECHANISM

Fig. No.	Part No.	Description	GC20688-DC	GC20688-BDC	Remarks
L43	HE64N18001	washer	1	1	
L44	H417040180	screw	1	1	M4×18
L45	H003002040	nut	1	1	4
L46	HE64N28001	bushing	1	1	
L47	HE64N38001	Spring	1	1	
L48	HE64N57101	Cam wheel assy	1	1	
L49	H428060080	screw	2	2	M6×8
L50	H415040080	screw	3	3	M4×8
L51	H005001040	washer	3	3	4
L52	HE64N88001	wheel	1	1	
L53	HE64N97101	link	1	1	
L54	HE65N18001	pin	1	1	
L55	HE65N28001	oil wick	1	1	
L56	HE65N48001	link	1	1	
L57	H427050060	screw	1	1	M5×6
L58	HE65N68001	shaft	1	1	
L59	HE65N78001	bushing	1	1	
L60	HE65N88001	screw	1	1	
L61	HE66N08001	link	1	1	
L62	HE66N18001	shaft	1	1	
L63	HE61N08001	bushing	2	2	
L64	HE66N28001	oil nozzle	1	1	
L65	H102050300	screw	1	1	M5×30
L66	HE66N38001	collar	1	1	
L67	H428040040	screw	1	1	M4×4
L68	H007013070	Retaining ring	1	1	
L69	HE66N48001	Setting block	1	1	
L70	H401030080	screw	1	1	M3×8
L71	H005001030	washer	1	1	
L72	HE66N57101	Oil allocator	1	1	
L73	HE62N58001	Oil joint	6	6	
L74	HE67N38001	oil tube	1	1	
L75	HE67N48001	Tube support	1	1	
L76	H415040100	screw	1	1	M4×10
L77	H005001040	washer	1	1	4
L78	H415050120	screw	2	2	M5×12
L79	H6510H8001	pin	2	2	B5×14
L80	HE67N77101	shaft complete	1	1	
L81	H415030100	screw	1	1	M3×10
L82	HE68N08001	oil wick	3	3	
L83	HE68N18001	link	1	1	
L84	HF979E8001	spacer	1	1	
L85	H401040040	screw	1	1	M4×4

L.KNIFFE MECHANISM

Fig. No.	Part No.	Description	GC20688-DC	GC20688-BDC	Remarks
L86	HE68N28001	pin	2	2	
L87	HE62N68001	bushing	2	2	
L88	HE68N48001	lever	1	1	
L89	HE68N58001	bushing	1	1	
L90	HE68N68001	link	1	1	
L91	H415050100	screw	1	1	
L92	HE68N88001	pin	1	1	
L93	HE68N98001	block	1	1	
L94	HE69N08001	control lever	1	1	
L95	HF01080300	hand knob	1	1	M8×30
L96	HE69N18001	block	1	1	
L97	H415030120	screw	1	1	M3×12
L98	HE69N28001	block	1	1	
L99	H415040080	screw	1	1	

SHANGHAI HUIGONG NO.3 SEWING MACHINE FACTORY

ADD: 1418, Yishan Road, Shanghai, China

Zip Code: 201103

Overseas Business: TEL: 86-21-64853303 FAX: 86-21-64854304

E-mail: highlead@online.sh.cn <http://www.highlead.com.cn>

The description covered in this manual is subject to change for improvement of the commodity without notice

2010.1. Printed

From the library of: Superior Sewing Machine & Supply LLC