

Purchasing Dept  
Copy

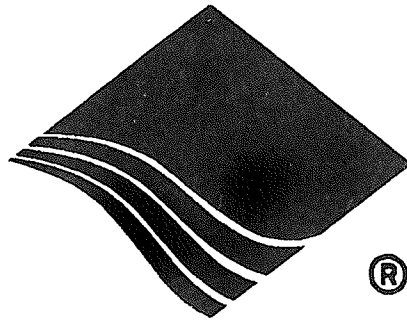

**HIGHLEAD**

**GC188-M/-H/-B**

**High Speed Single Needle Lockstitch Sewing  
Machine**

**Instruction Manual  
Parts Catalog**

**SHANGHAI HUIGONG NO.3 SEWING MACHINE FACTORY**

From the library of: Superior Sewing Machine & Supply LLC



---

## CONTENTS

|   |    |
|---|----|
| 1. PRECAUTIONS BEFORE STARTING OPERATION.....     | 2  |
| 2. MAIN SPECIFICATIONS.....                       | 2  |
| 3. PREPARATION AND LUBRICATION.....               | 3  |
| 4. REPLACE NEEDLES.....                           | 3  |
| 5. NEEDLE, THREAD AND MATERIAL TO BE SEWN.....    | 4  |
| 6. THREADING.....                                 | 4  |
| 7. WINDING ADJUSTMENT.....                        | 4  |
| 8. SET STITCH LENGTH AND REVERSE FEEDING.....     | 5  |
| 9. POSITION PRESSER BAR.....                      | 5  |
| 10. ADJUST THE PRESSURE OF PRESSER FOOT.....      | 5  |
| 11. ADJUST THREAD TAKE-UP SPRING.....             | 5  |
| 12. ADJUST THREAD TENSION.....                    | 6  |
| 13. ADJUST THREAD GUIDE AND THREAD TENSION.....   | 6  |
| 14. TIME NEEDLE TO ROTATING HOOK.....             | 7  |
| 15. REPLACE ROTATING HOOK.....                    | 8  |
| 16. ADJUST THE HEIGHT OF FEED DOG.....            | 8  |
| 17. ADJUST THE POSITION OF FEED DOG.....          | 9  |
| 18. TIME FEED MOTION TO NEEDLE MOTION.....        | 9  |
| 19. ADJUST OPENING TIME OF THE TENSION DISCS..... | 10 |
| 20. LUBRICATION ADJUSTMENT.....                   | 10 |
| 21. REGULAR CLEANING.....                         | 11 |

# 1. PRECAUTIONS BEFORE STARTING OPERATION

## 1) Safety Precautions:

- (1) When turning the power on, keep your hands and fingers away from the area around/under the needle and the area around the balance wheel.
- (2) Power must be turned off when the machine is not in use, or when the operator leaves the seat.
- (3) Power must be turned off when tilting the machine head, installing or removing the "V" belt, adjusting the machine, or when replacing.
- (4) Avoid placing fingers, hairs, bars etc., near the balance wheel, "V" belt, bobbin winder balance wheel, or motor when the machine is in operation.
- (5) Do not insert fingers into the thread take-up cover, under/around the needle, or balance wheel when the machine is in operation.
- (6) If a belt cover, finger guard, eye guard are installed, do not operate the machine without these safety devices.

## 2) Precautions before Starting Operation:

- (1) If the machine's oil pan has an oil sump, never operate the machine before filling it.
- (2) If the machine is lubricated by a drop oiler, never operate the machine before lubricating.
- (3) When a new sewing machine is first turned on, verify the rotational direction of the balance wheel with the power on. (The balance wheel should rotate counter-clockwise when viewed from the balance wheel)
- (4) Verify the voltage and (single or three) phase with those given on the machine nameplate.

## 3) Precautions for Operating Conditions:

- (1) Avoid using the machine at abnormally high temperature (35°C or higher) or low temperature (5°C or lower).
- (2) Avoid using the machine in dusty conditions.

# 2. MAIN SPECIFICATIONS

| Item                 | M                     | H                     | B                     |
|----------------------|-----------------------|-----------------------|-----------------------|
| Material             | Light                 | Medium-Heavy          |                       |
| Max. sewing speed    | 5000 rpm              | 3500 rpm              | 3000 rpm              |
| Stitch length        | 0-5mm                 | 0-8mm                 |                       |
| Needle bar stroke    | 31.8mm                | 35mm                  |                       |
| Presser              | By hand               | 6mm                   |                       |
|                      | By knee               | 13mm                  |                       |
| Needle               | DB / 1 #14            | DP / 5 #18            | DB / 1 #22            |
| Reversing mechanism  | <input type="radio"/> | <input type="radio"/> | <input type="radio"/> |
| Trimming mechanism   | <input type="radio"/> | <input type="radio"/> | <input type="radio"/> |
| Touch back mechanism | <input type="radio"/> | <input type="radio"/> | --                    |

### 3. PREPARATION AND LUBRICATION

#### 1) Cleaning the machine

Before leaving the factory, the machine parts are coated with rust-preventive grease, which may be hardened and contaminated by dust during storage and shipment. This grease must be removed with gasoline.

#### 2) Examination

Though every machine is confirmed by strict inspection and test before leaving the factory, the machine parts may be loose or deformed after long distance transportation with jolt. A thorough examination must be performed after cleaning the machine. Turn the balance wheel to see if there is running obstruction, parts collision, uneven resistance or abnormal noise. If these exist, adjustment must be made accordingly before run-in operation.

#### 3) Oiling (Fig.1)

##### (1) Required amount of oil

Line (A) on the oil reservoir: Max. Oil level

Line (B) on the oil reservoir: Min. Oil level

If oil level goes down under line (B), oil cannot be distributed to each part of the machine, thus causing the parts a seizure.

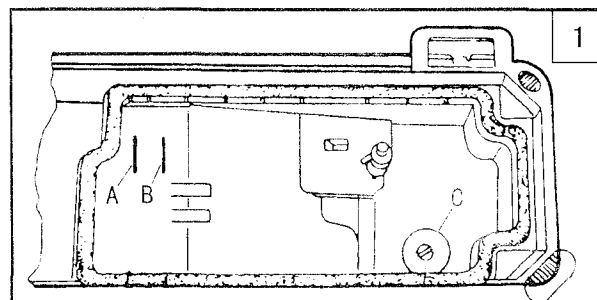

##### (2) Replenishing

Always use only No. 18 special machine oil for high speed sewing. Be sure to replenish oil to line (A) before starting operation.

##### (3) Replacing oil

To replace oil, remove screw (C) to drain oil. After completely draining off oil, clean the oil reservoir and securely tighten screw (C), then fill the reservoir with fresh oil.

#### 4. REPLACE NEEDLES (Fig.2)

Turn the balance wheel to lift needle bar to the upper end of its stroke. Loosen needle clamp screw (A). While keeping the long groove of the needle leftward fully insert the needle shank up to the bottom of the needle socket. Then tighten needle clamp screw (A).

**Note:** Fig. (b): insufficient insertion.

Fig. (c): wrong direction of long groove.

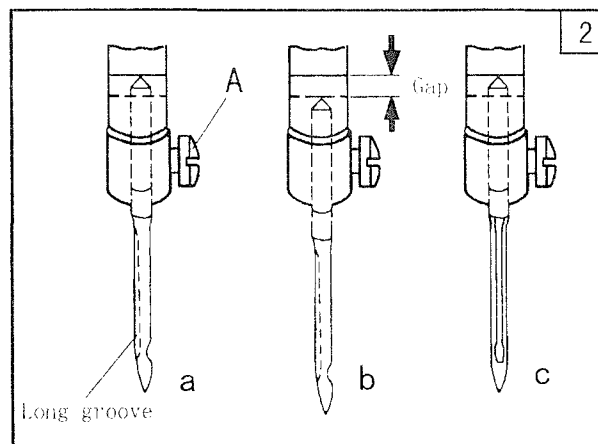

## 5. NEEDLE, THREAD AND MATERIAL TO BE SEWN

| Needle Size | Thread Number | Material                        |
|-------------|---------------|---------------------------------|
| No.9        | No.100- No.80 | crepe, georgette, organdie      |
| No.11       | No.80- No.60  | silk, muslin, poplin            |
| No.14       | No.60- No.50  | cotton, light, woolen           |
| No.16       | No.50- No.30  | woolen, tarpaulin, thin leather |

## 6. THREADING (Fig.3)

To thread the needle thread, raise needle bar to the upper end of its stroke, lead the thread from spool and perform threading as shown in Fig.3. To draw the bobbin thread, hold the end of the needle thread and turn the balance wheel to lower the needle bar and then to lift it to its highest position. Pull the needle thread and the bobbin thread is drawn up. Put the ends of needle thread and bobbin thread forward under presser foot.

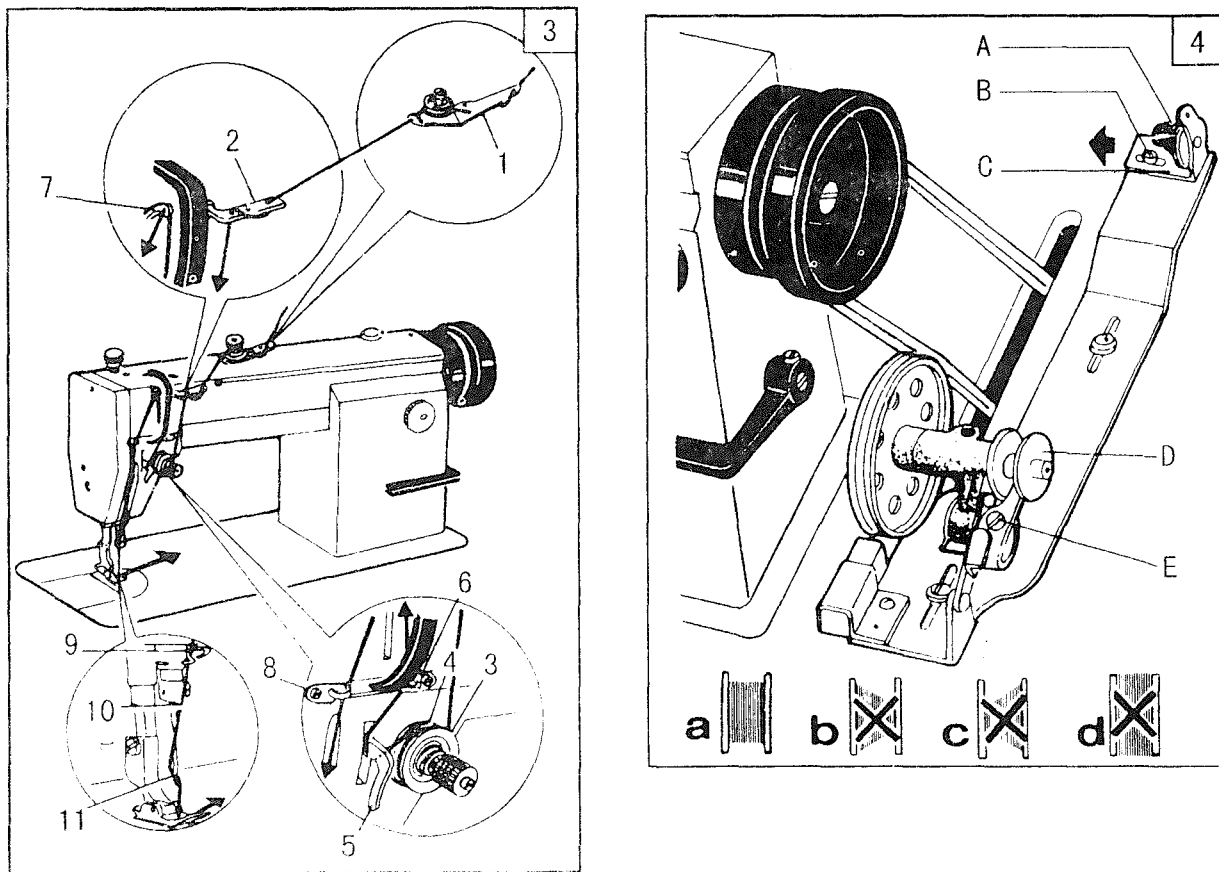

## 7. WINDING ADJUSTMENT (Fig.4)

1) The wound bobbin thread should be neat and tight, if not, adjust the winding tension by turning tension stud nut (A) of bobbin winder tension bracket.

**Note:** nylon or polyester thread should be wound with little tension; otherwise, bobbin (D) might break or deform.

2) When the wound thread layer does not present a cylindrical shape as shown in Fig 4 (a), loosen set screw (B) of bobbin winder tension bracket and slide bracket (C) leftward or rightward. If thread is wound as shown in Fig 4 (b), move the bracket rightward, but if thread is wound as shown in Fig 4 (c), move the bracket leftward.

After adequately positioning the bracket, tighten set screw (B).

3) Do not overfill the bobbin. The optimum length of thread will fill about 80% of bobbin capacity. This can be adjusted by adjusting screw (E) of bobbin winder stop latch.

## 8. SET STITCH LENGTH AND REVERSE FEEDING (Fig.5)

1) Stitch length can be set by turning dial (A).

2) The figures on face (B) of dial show stitch length in mm.

3) Reverse feeding starts when reverse feed lever (C) is depressed, and the machine will feed forward again if reverse feed lever (C) is released.

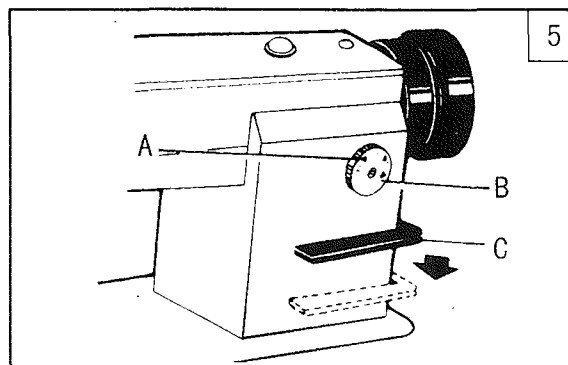

## 9. POSITION PRESSER BAR (Fig.6)

1) Loosen lock nut (E) and pressure regulating thumb screw (A).

2) Remove Rubber Plug from face plate (B).

3) Loosen screw (C) and adjust the position of Presser Bar till the presser foot is 6 mm above the throat plate will the presser foot lifted to its highest.

4) Tighten screw (C) and put in the rubber plug.

5) Tighten pressure regulating thumb screw (A) and lock nut (E).

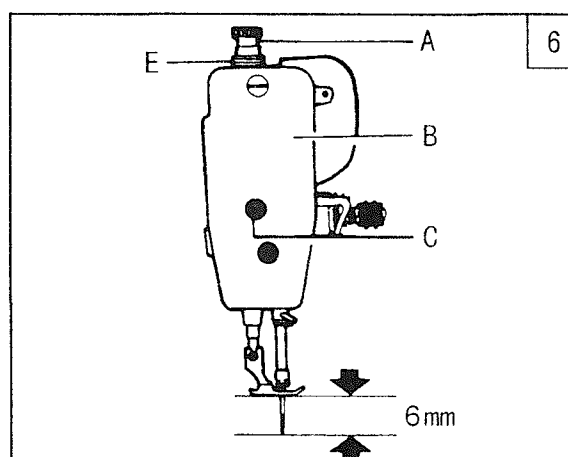

## 10. ADJUST THE PRESSURE OF PRESSER FOOT (Fig.7)

Pressure of presser foot is to be adjusted in accordance with thickness of materials to be sewn.

First loosen lock nut (A). For heavy materials, turn the pressure regulating thumb screw as shown in Fig.7 (a) to increase the pressure, while for light materials, turn the pressure regulating thumb screw as shown in Fig.7 (b) to decrease the pressure. Then tighten lock nut (A).

The pressure of presser foot is recommended to be less as long as normal feeding is ensured.

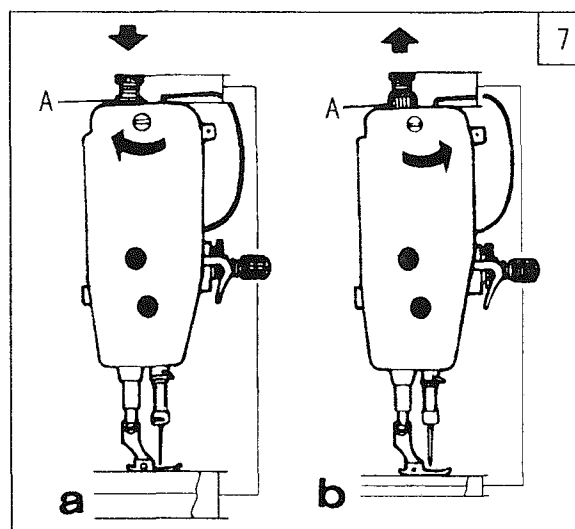

## 11. ADJUST THREAD TAKE-UP SPRING (Fig.8, 9)

### 1) Adjusting the thread take-up spring tension

Loosen set screw (A), turn tension stud (B) clockwise to increase the spring tension, or turn the stud counter-clockwise to decrease the spring tension. After the adjustment, be sure to tighten set screw (A). The thread take-up spring tension should be about 30g. To attain this, First loosen set screw (A), turn tension stud (B) counter-clockwise to decrease the tension of thread take-up spring (C) to zero, then turn tension stud (B)

clockwise until spring (C) comes to the notch of thread tension regulating bushing, and again turn tension stud (B) halfway back (counter-clockwise) After the adjustment, tighten set screw (A).

## 2) Adjusting the thread take-up spring stroke

Loosen set screw (B), turn stud (C) clockwise to increase the stroke or turn stud (C) counter-clockwise to decrease the stroke. After the adjustment, tighten set screw (B).

Before leaving the factory, the thread take-up spring has properly been adjusted. Readjustment is needed only in the case of special material or special thread.

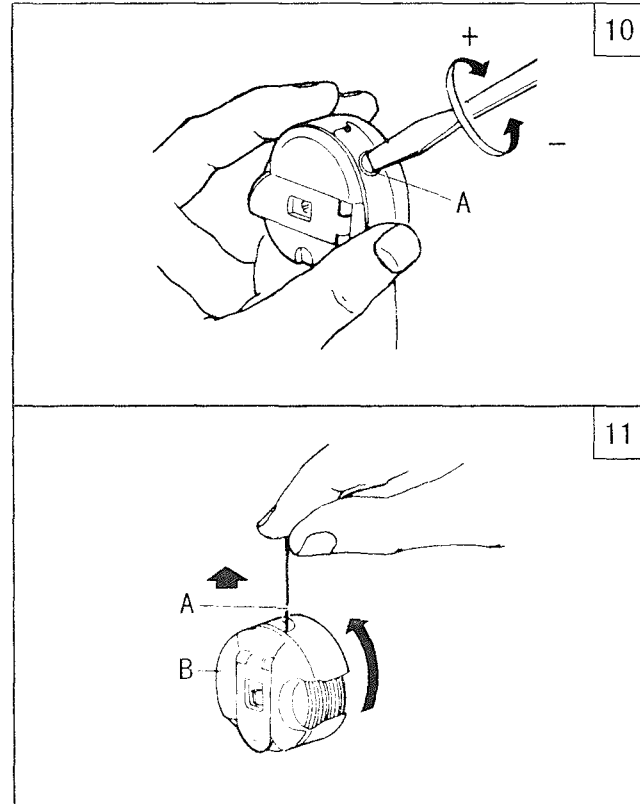
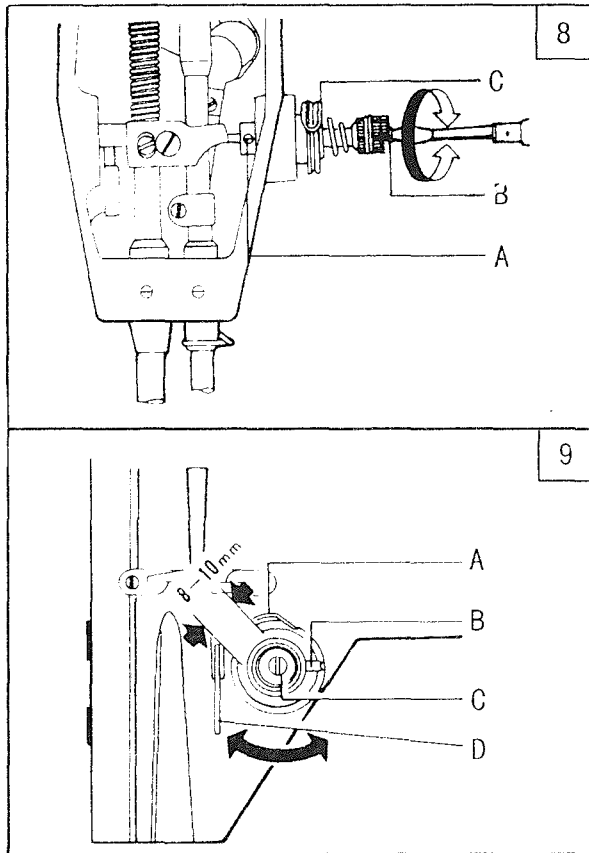

## 12. ADJUST THREAD TENSION (Fig.10, 11)

In principle, thread tension is to be adjusted in accordance with materials, thread and other factors.

In practice, thread tension is adjusted according to the stitches obtained. The needle thread tension should be adjusted with reference to the bobbin thread tension. Turn tension spring regulating screw (A) of bobbin case clockwise for more tension, or turn the screw counter-clockwise for less tension.

It is common practice to test the bobbin test the bobbin thread tension as shown in Fig.11. Hold the end of the thread from delivery eye. If the bobbin case is falling slowly, the proper tension is obtained. The needle thread tension can be adjusted by setting (1) the take-up spring tension, (2) the thread take-up spring stroke and (3) tension spring. All these adjustments will be described in the following.

## 13. ADJUST THREAD GUIDE AND THREAD TENSION (Fig.12, 13)

The position of the thread guide affects stitch tightness and therefore must be adjusted according to sewing materials and sewing conditions.



|                       |          |        |           |
|-----------------------|----------|--------|-----------|
| Thread guide position | 1        | 2      | 3         |
|                       | Leftward | Center | Rightward |
| Material weight       | Heavy    | Medium | Light     |

Fig.12 shows different stitch forms. Normal stitch form should be as shown in Fig.12 (a). When abnormal stitches cause puckering and thread break-age, the tension of needle thread and bobbin thread must be adjusted accordingly.

1) In case needle thread tension is too strong or bobbin thread tension is too weak, as shown in Fig.12 (b), turn the thumb nut counter-clockwise to decrease the needle thread tension, or tighten the tension spring regulating screw of bobbin case to increase the bobbin thread tension (Fig. 13)

2) In case needle thread tension is too weak or bobbin thread tension is too strong, as shown in Fig.12 (c), turn the thumb nut clockwise to increase the needle thread tension, or loosen the tension spring regulating screw of bobbin case to decrease the bobbin thread tension.

3) In case of the stitch forms as shown in Fig.12 (d) and (e), adjustments can be made with reference to the above means.

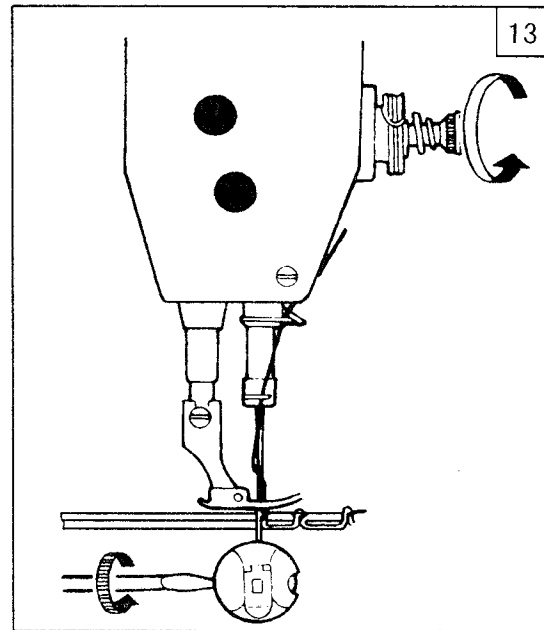
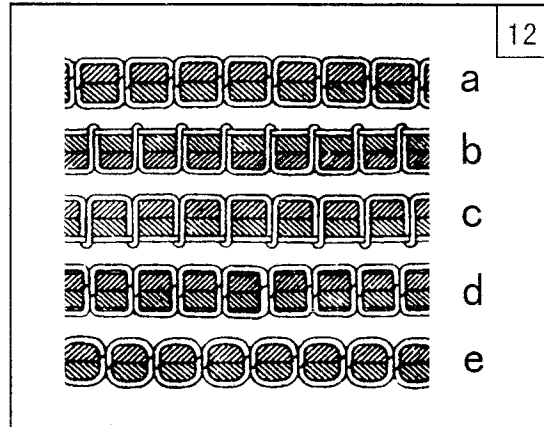

## 14. TIME NEEDLE TO ROTAING HOOK

(Fig. 14, 15, 16, 17)

### 1) Adjusting the needle position (Fig.14)

- (1) Turn balance wheel by hand to bring needle bar (C) to the lowest position of its stroke.
- (2) Remove rubber plug from face plate (A).
- (3) Loosen set screw (B) of needle bar adaptor.
- (4) Move needle bar (C) vertically to adjust needle timing.

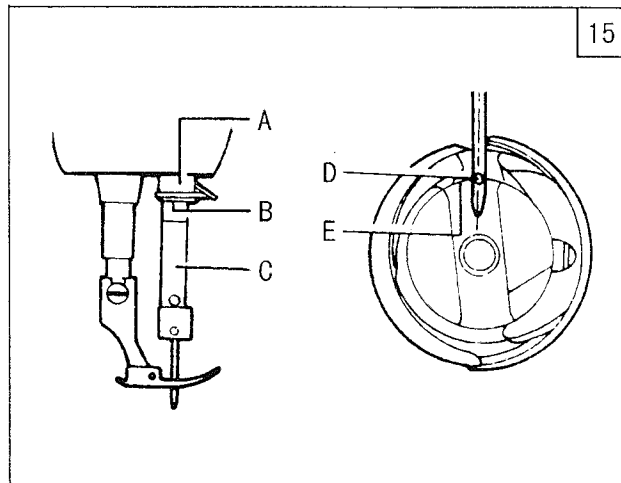
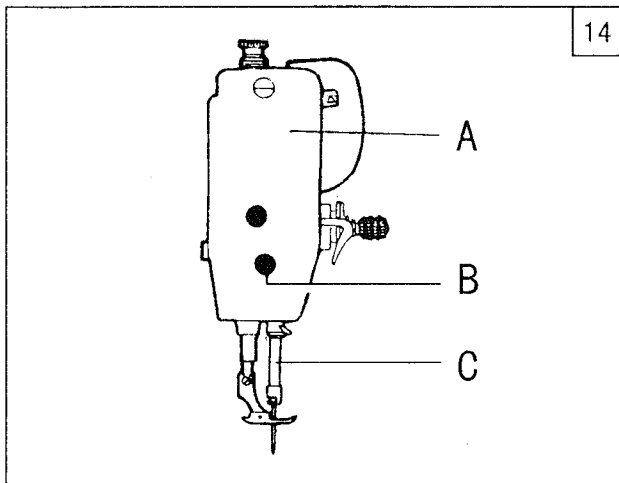

(5) After the adjustment, tighten set screw (B) and put in the rubber plug. The standard needle timing (Fig.15) is to align timing mark (B) on the needle bar and the bottom of needle bar bushing (A) and meanwhile align the inner surface (E) of the hook and the center of needle eye (D) when the needle bar gets down to its lowest position.

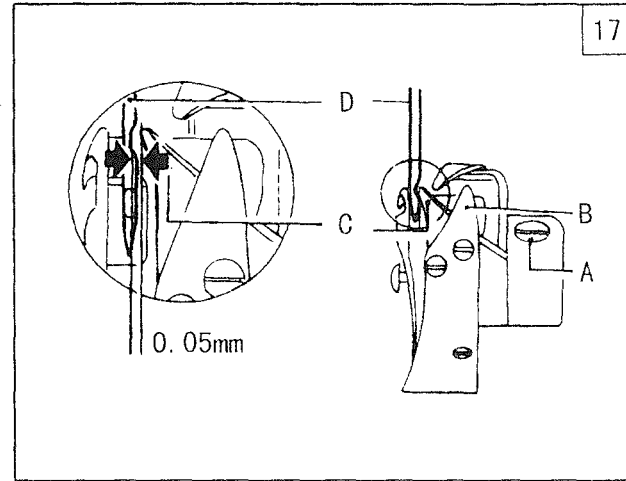
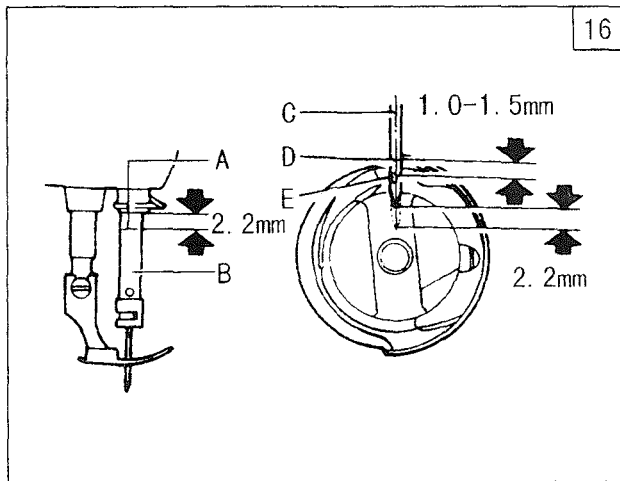

## 2) Adjusting the hook point timing

Timing of needle motion to rotating hook motion has a great effect on sewing performance. The standard hook point timing (Fig.16) is to align hook point (D) and needle centerline (C) when needle bar (B) is lifted by 2.2mm from the lower end of its stroke. Besides, hook point (D) should be 1.0-1.5mm above the upper end of needle eye (E).

When adjusting the hook point timing, also notice that the clearance between the bottom of needle notch and hook point (C) should be approx. 0.05mm (Fig.17)

## 15. REPLACE ROTATING HOOK (Fig.18)

- 1) Lift needle bar to the highest position of its stroke.
- 2) Remove throat plate, take down needle and bobbin case.
- 3) Loosen screw (C) of hook positioner and take down hook positioner (A).
- 4) Loosen two screw (D) of rotating hook.
- 5) Turn the balance wheel to raise feed bar to its highest position, then take down the rotating hook by turning it away from feed bar.
- 6) Installing the hook can be done in reverse sequence. Note that needle (B) and the convex surface of hook positioner (A) should align with a clearance of 0.5-0.7mm between them.

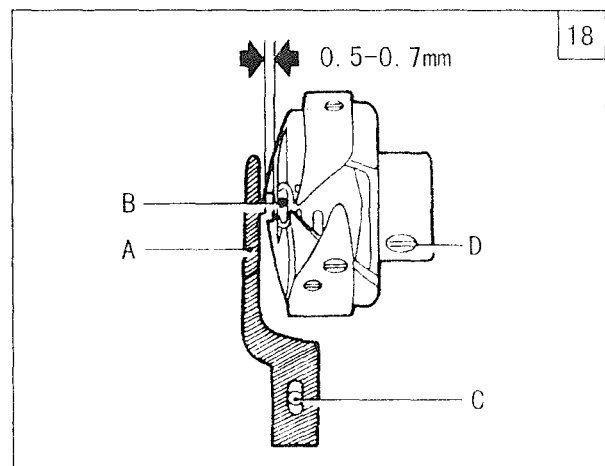

## 16. ADJUST THE HEIGHT OF FEED DOG (Fig.19, 20)

- 1) Turn the balance wheel until feed dog is lifted to its highest position from throat plate surface.

- 2) Loosen screw (A) of feed lifting rock shaft crank right (See Fig.19, b)
- 3) Move feed bar (B) in the direction shown by the arrow in Fig.19 (a) to adjust the height of the feed dog.  
The standard height of feed dog is that the top of feed dog is 0.8mm above throat plate surface (B).
- 4) After the adjustment, be sure to tighten screw (A).

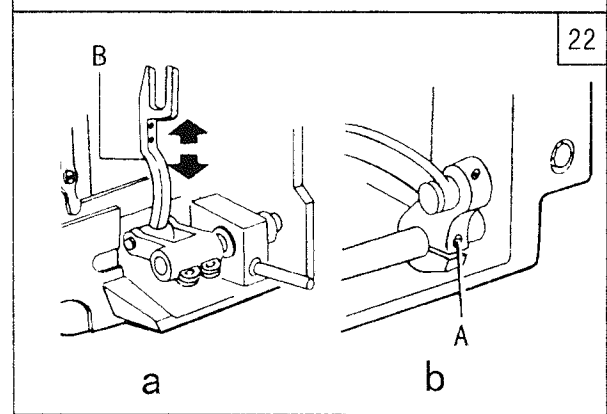
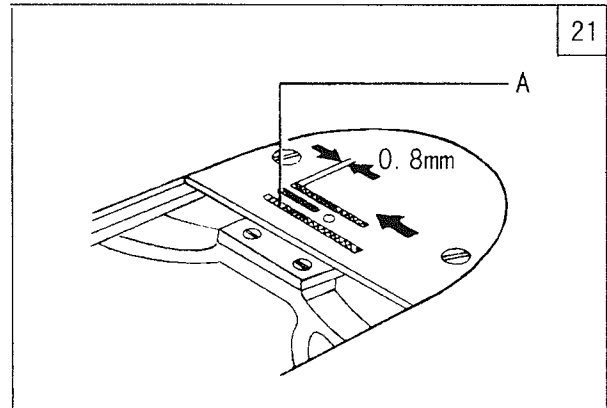
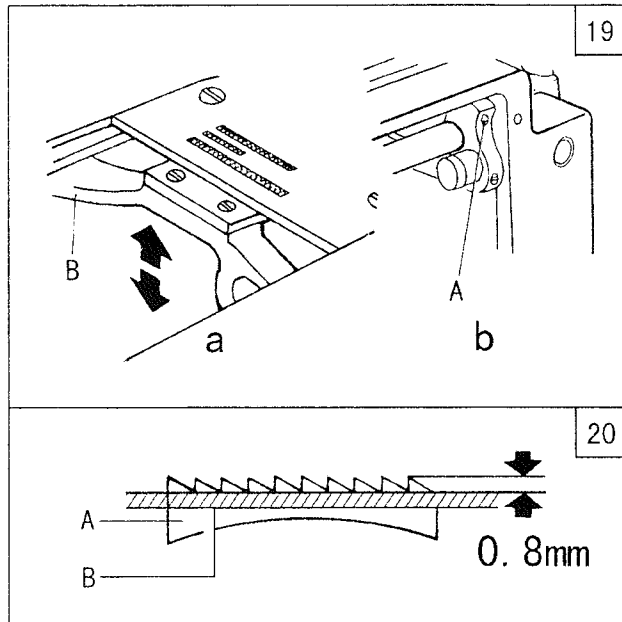

## 17. ADJUST THE POSITION OF FEED DOG (Fig.21, 22)

The standard position of feed dog is that the clearance between the front end of the throat plate slot and the first tooth of the fully advanced feed dog is 0.8 mm, as shown in Fig.21.

- 1) Fully advance the feed dog toward the front end of the throat plate slot.
- 2) Loosen feed rock shaft crank screw (A). See Fig.22 (b).
- 3) Move feed bar (B) in the direction shown by the arrow in Fig. 22 (a) to adjust the feed dog position.
- 4) After the adjustment, be sure to tighten Screw (A).

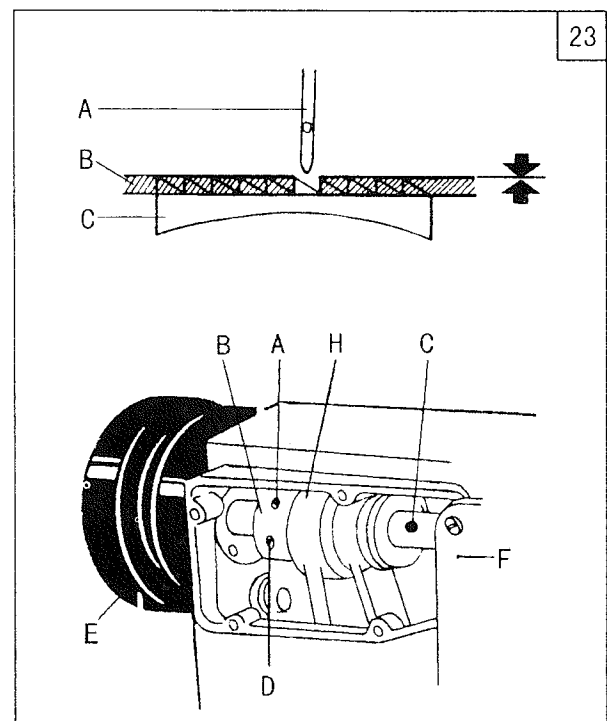

## 18. TIME FEED MOTION TO NEEDLE MOTION (Fig.23, 24)

The standard timing of feed motion to needle motion is that the top of feed dog (C) is flush with throat plate surface (B) when the point of needle (A) reaches throat plate surface (B). (Fig.23.)

If feed motion is not timed to needle motion, adjust as follows (Fig.23 and Fig.24).

1) Remove arm side cover (F).

2) Loosen set screws (A) and (D) of feed and feed lifting eccentric.

3) Hold feed and feed lifting eccentric (B) and turn balance wheel (E) slowly until the upper edge of arm shaft oil hole (C) aligns with the lower edge of reference hole (G) of feed and feed lifting eccentric.

4) Leave a clearance of 0.3-0.5mm between feed and feed lifting eccentric (B) and eccentric sleeve (H), then tighten set screws (A) and (D).

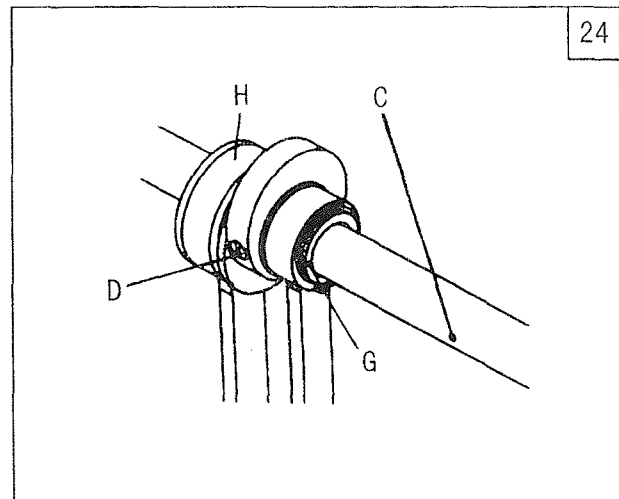

## 19. ADJUST OPENING TIME OF THE TENSION DISCS (Fig.25)

Within the presser foot lift range of 2-7mm opening time of the tension discs can be adjusted as follows:

1) Remove the rubber plug from the back of arm and loosen screw (A) of knee lifter lever (left).

2) Move the tension releasing cam leftward for earlier opening or rightward for later opening. It will facilitate the adjustment to put under the presser foot a block as thick as the presser foot lift.

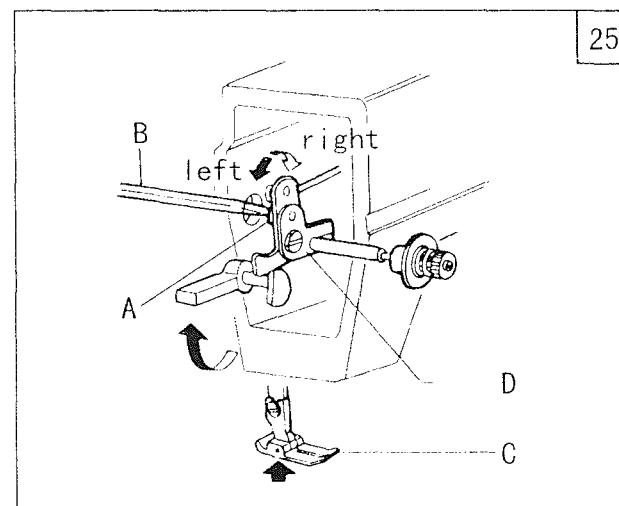

## 20. LUBRICATION ADJUSTMENT (Fig.26)

Adjusting the lubrication of rotating hook.

Oil adjusting screw (A) can adjust the lubrication of the rotating hook as follows:

(1) Turn oil adjusting screw (A) clockwise to increase oil and turn oil adjusting screw (A) counter-clockwise to decrease oil.

(2) Oil adjusting screw (A) adjusts oil amount within 5 turns. When oil adjusting screw (A) is fully tightened, oil amount is maximum.

(3) Readjustment depends on temperature, sewing speed and the like. In practice, oil amount can be judged as follows: remove the throat plate and place a piece of paper on instead, run the machine for about 20 seconds, then check the oil splashed on the paper.

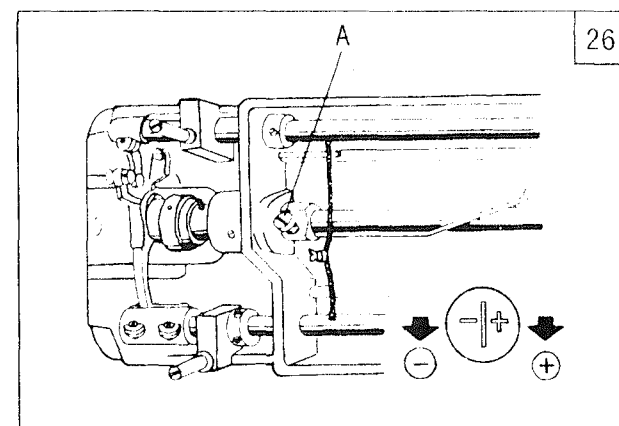

## 21. REGULAR CLEANING (Fig.27)

### 1) Cleaning feed dog

Remove the throat plate and clear off the dust and lint between feed dog tooth slots.

### 2) Cleaning rotating hook

Swing out the machine head and clean the hook. Wipe the bobbin case with soft cloth.

### 3) Cleaning oil pump, screen

Swing out the machine head and clear off the dust and dirt on oil pump screen.

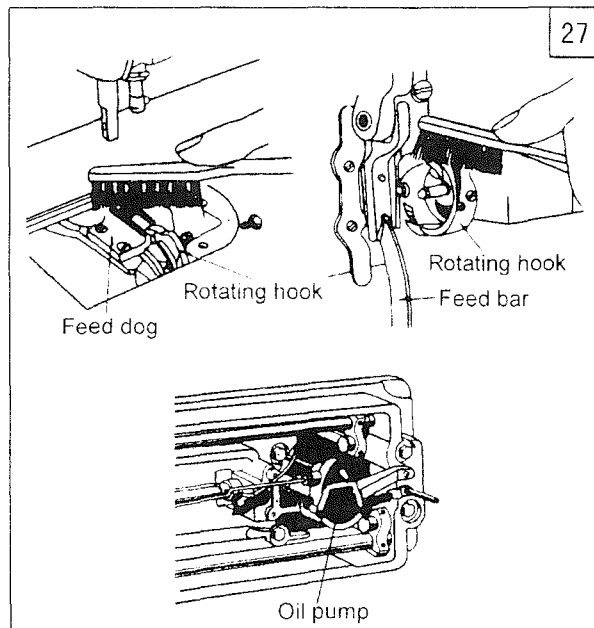

# A.ARM BED AND ITS ACCESSORIES

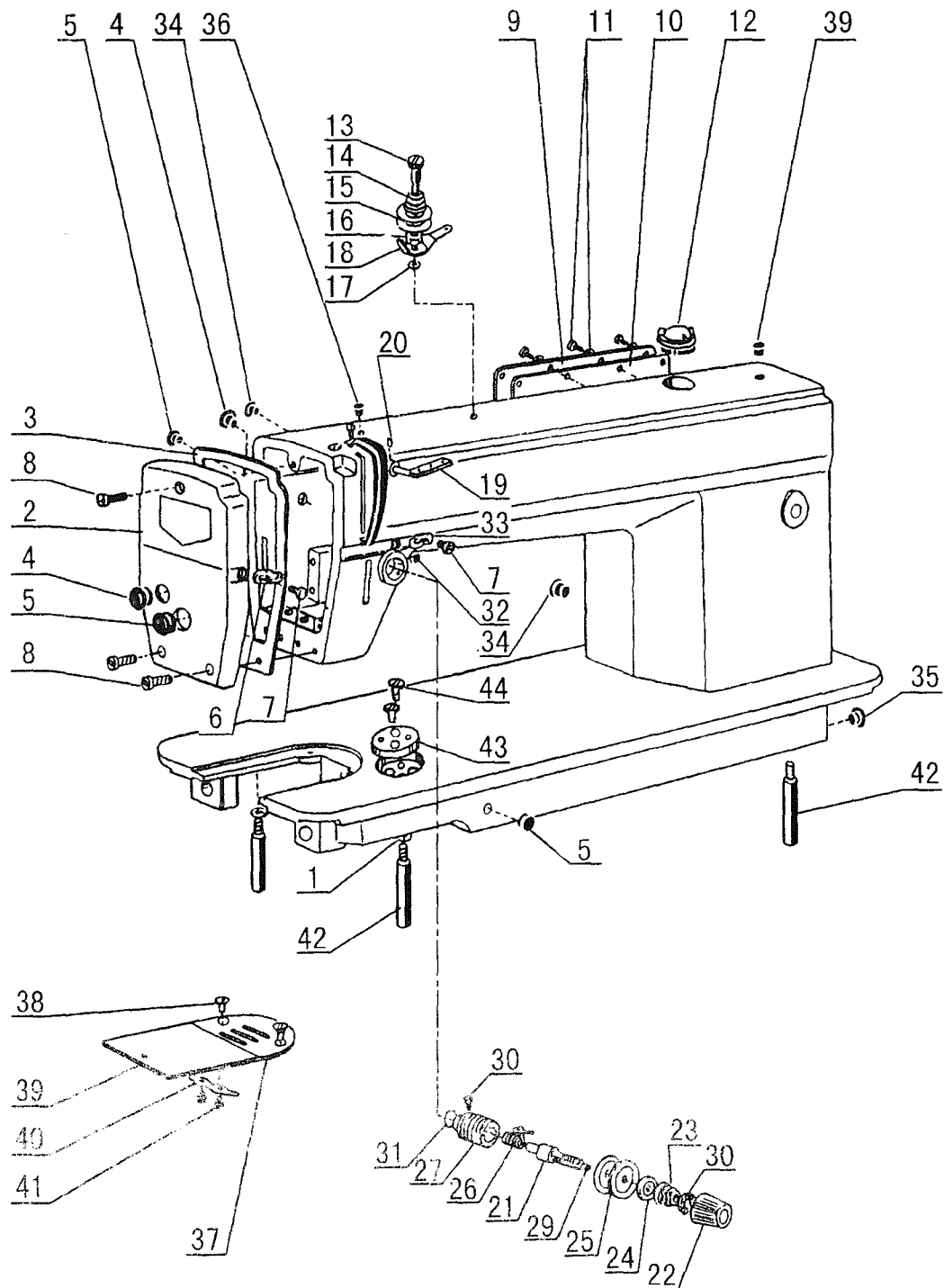

## A.ARM BED AND ITS ACCESSORIES

| Fig. No. | Part No.   | Description                       | M | H | B | Remarks                  |
|----------|------------|-----------------------------------|---|---|---|--------------------------|
| A01      | H005008060 | Spring washer                     | 3 | 3 | 3 |                          |
| A02      | H5408B0661 | Face plate                        | 1 | 1 | 1 |                          |
| A03      | H5408B0662 | Gasket for face plate             | 1 | 1 | 1 |                          |
| A04      | HA307B0673 | Rubber plug( $\Phi$ 19)           | 2 | 2 | 2 |                          |
| A05      | HA307B0674 | Rubber plug( $\Phi$ 11.8)         | 3 | 3 | 3 |                          |
| A06      | HA106B0675 | Thread guide on face plate        | 1 | 1 |   |                          |
| A06      | HA607B0671 | Thread guide on face plate        |   |   | 1 |                          |
| A07      | HA106B0676 | Screw                             | 2 | 2 | 2 | SM9/64(40) $\times$ 6    |
| A08      | HA300B2160 | Screw                             | 3 | 3 | 3 | SM11/64(40) $\times$ 10  |
| A09      | HA308B0681 | Arm side cover                    | 1 | 1 | 1 |                          |
| A10      | HA108B0682 | Gasket for arm side cover         | 1 | 1 | 1 |                          |
| A11      | HA300B2170 | Screw                             | 8 | 8 | 8 | SM11/64(40) $\times$ 9   |
| A12      | H1210B0671 | Oil check window                  | 1 | 1 | 1 |                          |
| A13      | HA112B0691 | Screw type tension stud           | 1 | 1 | 1 |                          |
| A14      | HA112B0692 | Spring for pre-tension            | 1 | 1 | 1 |                          |
| A15      | HA112B0693 | Disk for pre-tension              | 2 | 2 | 2 |                          |
| A16      | HA112B0694 | Space for pre-tension             | 1 | 1 | 1 |                          |
| A17      | H007013030 | Stop ring                         | 1 | 1 | 1 |                          |
| A18      | HA112B0695 | Pre-tension thread guide          | 1 | 1 | 1 |                          |
| A19      | HA100B2100 | Three-hole thread guide           | 1 | 1 | 1 |                          |
| A20      | HA100B2110 | Set screw                         | 1 | 1 | 1 | SM11/64(40) $\times$ 5.5 |
| A21      | HA115B0701 | Thread tension stud               | 1 | 1 | 1 |                          |
| A22      | HA310B0701 | Thumb nut                         | 1 | 1 | 1 |                          |
| A23      | HA115B0703 | Thread tension spring             | 1 |   |   |                          |
| A23      | HA505B0671 | Thread tension spring             |   | 1 |   |                          |
| A23      | HA607B0068 | Thread tension spring             |   |   | 1 |                          |
| A24      | HA310B0702 | Thread tension disc               | 1 | 1 | 1 |                          |
| A25      | HA310B0705 | Thread tension disc               | 2 | 2 | 2 |                          |
| A26      | HA115B0706 | Thread take-up spring             | 1 |   |   |                          |
| A26      | HA505B0672 | Thread take-up spring             |   | 1 | 1 |                          |
| A27      | HA310B0703 | Thread tension regulating bushing | 1 | 1 | 1 |                          |
| A28      | HA115B0708 | Set screw                         | 1 | 1 | 1 | SM9/64(40) $\times$ 6    |
| A29      | HA115B0709 | Thread tension releasing pin      | 1 | 1 | 1 |                          |
| A30      | HA115B7010 | Stop disc                         | 1 | 1 | 1 |                          |
| A31      | HA115B7011 | Rubber ring                       | 1 | 1 | 1 |                          |
| A32      | HA300B2080 | Set screw                         | 1 | 1 | 1 | SM15/64(28) $\times$ 6.8 |
| A33      | HA100B2140 | Thread guide                      | 1 | 1 |   |                          |
| A33      | HA600B2050 | Thread guide                      |   |   | 1 |                          |
| A34      | HA300B2090 | Rubber plug( $\Phi$ 8.8)          | 3 | 3 | 3 |                          |
| A35      | HA300B2100 | Rubber plug( $\Phi$ 27)           | 1 | 1 | 1 |                          |
| A36      | HA300B2110 | Rubber plug( $\Phi$ 5.7)          | 2 | 2 | 2 |                          |
| A37      | HA300B2120 | Needle plate                      | 1 |   |   |                          |
| A37      | HA500B2030 | Needle plate                      |   | 1 | 1 |                          |

## A.ARM BED AND ITS ACCESSORIES

| Fig. No. | Part No.   | Description        | M | H | B | Remarks         |
|----------|------------|--------------------|---|---|---|-----------------|
| A38      | HA300B2190 | Needle plate screw | 2 | 2 | 2 | SM11/64(40)×4.5 |
| A39      | HA124B0711 | Slide plate        | 1 | 1 | 1 |                 |
| A40      | HA124B0712 | Slide plate spring | 1 | 1 | 1 |                 |
| A41      | HA124B0713 | Screw              | 2 | 2 | 2 |                 |
| A42      | HA100B2220 | Leg                | 3 | 3 | 3 |                 |
| A43      | HA300B2140 | Cloth guide plate  | 1 | 1 | 1 |                 |
| A44      | HA300B2130 | Screw              | 2 | 2 | 2 |                 |



# B.NEEDLE BAR AND THREAD TAKE-UP MECHANISM

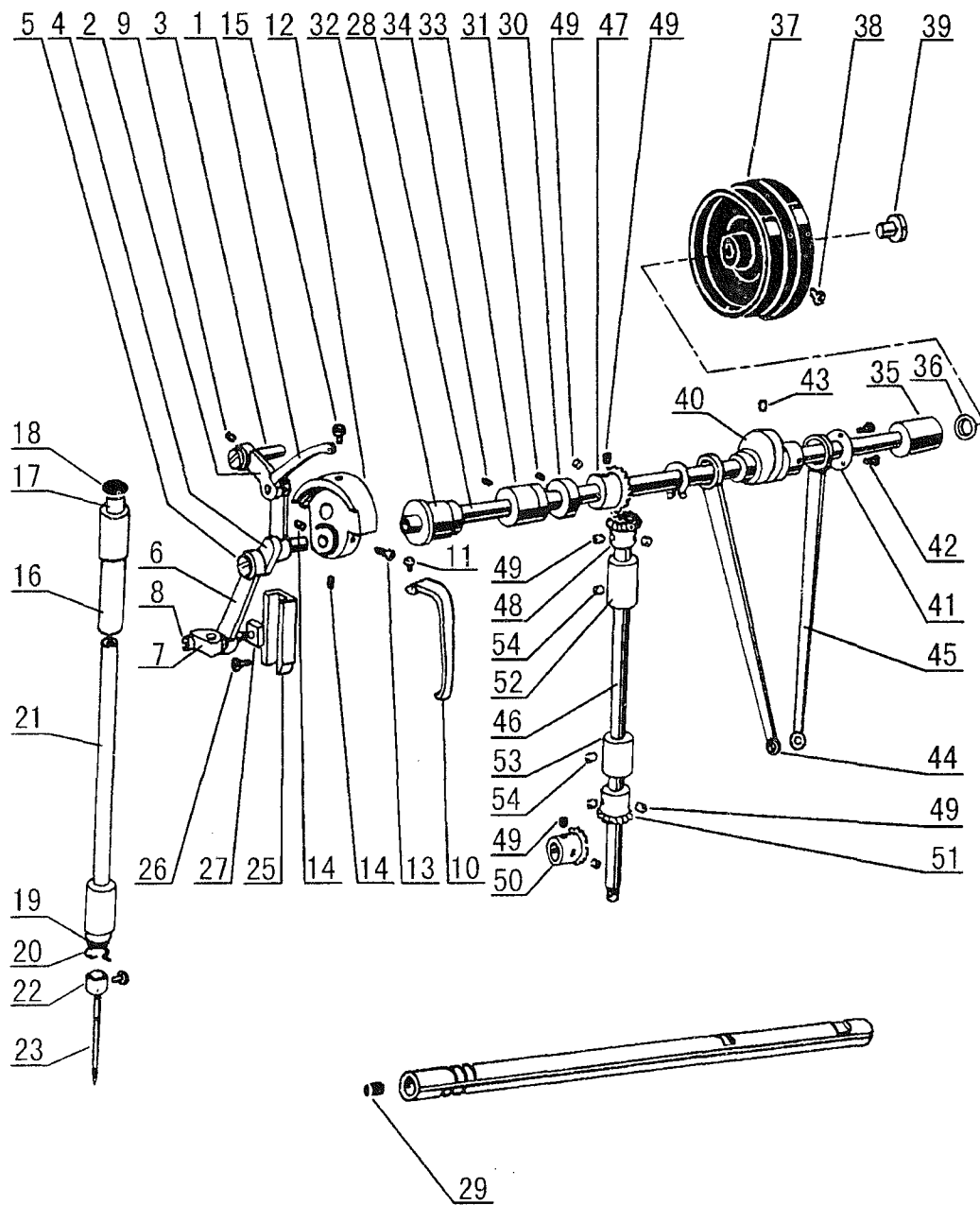

## B.NEEDLE BAR AND THREAD TAKE-UP MECHANISM

| Fig. No. | Part No.   | Description                 | M | H | B | Remarks        |
|----------|------------|-----------------------------|---|---|---|----------------|
| B01      | HA1111C104 | Thread take-up lever        | 1 |   |   |                |
| B01      | HA3111C104 | Thread take-up lever        |   | 1 |   |                |
| B01      | HA6111C104 | Thread take-up lever        |   |   | 1 |                |
| B02      | HA104C0652 | Thread take-up lever link   | 1 |   |   |                |
| B02      | HA304C0012 | Thread take-up lever link   |   | 1 | 1 |                |
| B03      | HA104C0653 | Hinge pin                   | 1 | 1 | 1 |                |
| B04      | HA104C0654 | Thread take-up crank        | 1 |   |   |                |
| B04      | HA504C0651 | Thread take-up crank        |   | 1 | 1 |                |
| B05      | HA104C0656 | Screw(left-handed)          | 1 | 1 | 1 |                |
| B06      | HA1172C104 | Needle bar link             | 1 |   |   |                |
| B06      | HA3172C104 | Needle bar link             |   | 1 | 1 |                |
| B07      | HA104C0658 | Needle bar adaptor          | 1 | 1 | 1 |                |
| B08      | HA106B0676 | Set screw                   | 1 | 1 |   | SM9/64(40)×6   |
| B08      | HA104C0659 | Set screw                   |   |   | 1 | SM9/64(40)×6   |
| B09      | HA100C2020 | Set screw                   | 1 | 1 | 1 | SM15/64(28)×10 |
| B10      | HA300C2020 | Thread take-up guard        | 1 | 1 |   |                |
| B10      | HA600C2020 | Thread take-up guard        |   |   | 1 |                |
| B11      | HA300C2030 | Set screw                   | 1 | 1 | 1 | SM11/64(40)×8  |
| B12      | HA108C0661 | Needle bar crank            | 1 |   |   |                |
| B12      | HA307C0661 | Needle bar crank            |   | 1 | 1 |                |
| B13      | HA100C2060 | Screw                       | 1 | 1 | 1 | SM9/32(28)×13  |
| B14      | HA307C0662 | Screw                       | 2 | 2 | 2 | SM1/4(40)×6    |
| B15      | HA100C2070 | Screw                       | 1 | 1 | 1 | SM9/32(28)×14  |
| B16      | HA100C2080 | Needle bar bushing(upper)   | 1 | 1 | 1 |                |
| B17      | HA100C2100 | Felt plug                   | 1 | 1 | 1 |                |
| B18      | HA300C2050 | Rubber plug                 | 1 | 1 | 1 |                |
| B19      | HA300C2060 | Needle bar bushing(lower)   | 1 |   |   |                |
| B19      | HA804B0652 | Needle bar bushing(lower)   |   | 1 | 1 |                |
| B20      | HA300C2070 | Thread guide                | 1 | 1 | 1 |                |
| B21      | HA300C2080 | Needle bar                  | 1 |   |   |                |
| B21      | HA500C2020 | Needle bar                  |   | 1 | 1 |                |
| B22      | HA100C2150 | Thread guide for needle bar | 1 |   |   |                |
| B22      | HA500C2030 | Thread guide for needle bar |   | 1 | 1 |                |
| B23      | HA100C2160 | Needle                      | 1 |   |   |                |
| B23      | H1000C2010 | Needle                      |   | 1 |   |                |
| B23      | HA500C2040 | Needle                      |   |   | 1 |                |
| B24      | HA100C2170 | Screw                       | 1 | 1 | 1 | SM1/8(44)×4.5  |
| B25      | HA100C2180 | Guide for lide block        | 1 | 1 | 1 |                |
| B26      | HA100C2190 | Set screw                   | 2 | 2 | 2 | SM11/64(40)×8  |
| B27      | HA100C2200 | Slide block                 | 1 | 1 | 1 |                |
| B28      | H1204C0651 | Arm shaft                   | 1 | 1 | 1 |                |
| B29      | HA104D0652 | Rubber plug(Φ7.4×10)        | 2 | 2 | 2 |                |
| B30      | HA108G0661 | Collar for arm shaft        | 1 | 1 | 1 |                |

## B.NEEDLE BAR AND THREAD TAKE-UP MECHANISM

| Fig. No. | Part No.   | Description                          | M | H | B | Remarks        |
|----------|------------|--------------------------------------|---|---|---|----------------|
| B31      | HA105D0662 | Set screw                            | 2 | 2 | 2 |                |
| B32      | HA100D2030 | Arm shaft bushing(left)              | 1 | 1 | 1 |                |
| B33      | HA100D2040 | Arm shaft bushing(middle)            | 1 | 1 | 1 |                |
| B34      | HA100C2020 | Set screw                            | 1 | 1 | 1 |                |
| B35      | HA300D2020 | Arm shaft bushing(right)             | 1 | 1 | 1 |                |
| B36      | HA306D0066 | Oil seal                             | 1 | 1 | 1 |                |
| B37      | HA307D0671 | Balance wheel                        | 1 | 1 |   |                |
| B37      | H2000C2040 | Balance wheel                        |   |   | 1 |                |
| B38      | HA110D0672 | Set screw                            | 2 | 2 | 2 | SM15/64(28)×12 |
| B39      | HA100D2080 | Screw                                | 1 | 1 | 1 | SM11/32(28)×10 |
| B40      | HA7311C106 | Feed and feed lifting eccentric      | 1 |   |   |                |
| B40      | HA8211C105 | Feed and feed lifting eccentric      |   | 1 | 1 |                |
| B41      | HA7311C206 | Washer                               | 1 | 1 | 1 |                |
| B42      | HA7311C306 | Set screw                            | 3 | 3 | 3 |                |
| B43      | HA100C2020 | Set screw                            | 2 | 2 | 2 | SM15/64(28)×10 |
| B44      | HA112D3013 | Crank rod for feed lifting rock      | 1 | 1 | 1 |                |
| B45      | HA7311C506 | Crank rod for feed rock shaft        | 1 | 1 | 1 |                |
| B46      | HA113D0691 | Vertical shaft                       | 1 | 1 | 1 |                |
| B47      | HA113B2112 | Bevel gear for arm shaft             | 1 | 1 | 1 | Z=27           |
| B48      | HA113D2122 | Bevel gear for vertical shaft(up)    | 1 | 1 | 1 | Z=18           |
| B49      | HA108C0663 | Set screw                            | 8 | 8 | 8 | SM1/4(40)×7    |
| B50      | HA113D2212 | Bevel gear for hook shaft            | 1 | 1 | 1 | Z=21           |
| B51      | HA113D2222 | Bevel gear for vertical shaft(lower) | 1 | 1 | 1 | Z=28           |
| B52      | HA100D2110 | Vertical shaft bushing(upper)        | 1 | 1 | 1 |                |
| B53      | HA100D2110 | Vertical shaft bushing(lower)        | 1 | 1 |   |                |
| B53      | HA600D2010 | Vertical shaft bushing(lower)        |   |   | 1 |                |
| B54      | HA100C2020 | Set screw                            | 2 | 2 | 2 | SM15/64(28)×10 |

# C.FEEDING AND FEED LIFTING & LOWER SHAFT MECHANISM

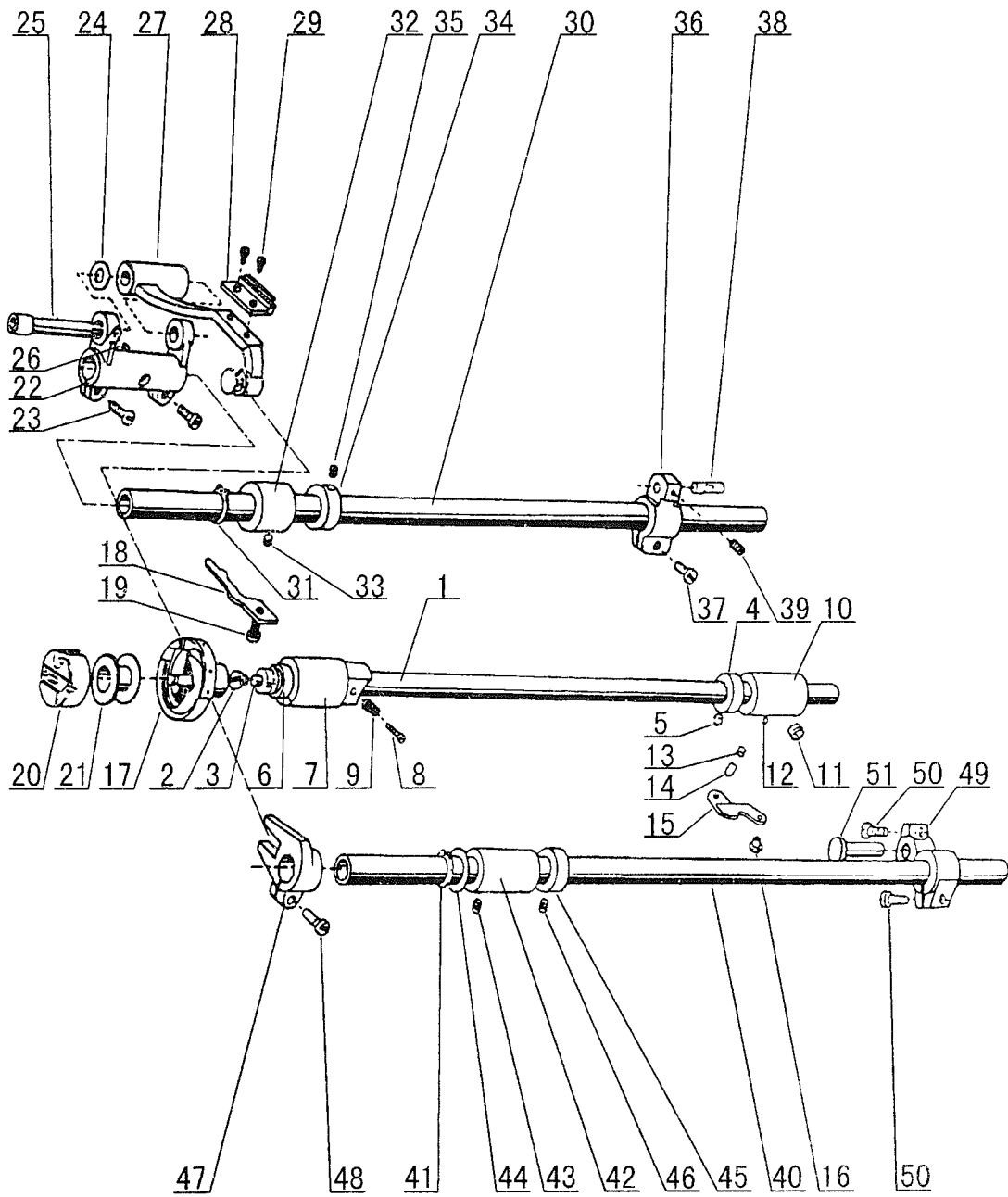

## C.FEEDING AND FEED LIFTING & LOWER SHAFT MECHANISM

| Fig. No. | Part No.   | Description                      | M | H | B | Remarks         |
|----------|------------|----------------------------------|---|---|---|-----------------|
| C01      | HA704E0651 | Rotating hook shaft              | 1 | 1 |   |                 |
| C01      | HA904E0651 | Rotating hook shaft              |   |   | 1 |                 |
| C02      | HA1111E104 | Filter screw                     | 1 | 1 | 1 |                 |
| C03      | HA1111E204 | Filter                           | 1 |   |   |                 |
| C03      | H1006E8001 | Oil wick                         |   | 1 | 1 |                 |
| C04      | HA305E0661 | Collar for rotating hook shaft   | 1 | 1 | 1 |                 |
| C05      | HA305E0662 | Set screw                        | 2 | 2 | 2 | SM15/64(28)×4.5 |
| C06      | HA106E0071 | Oil seal for rotating hook shaft | 1 | 1 | 1 |                 |
| C07      | HA100E2040 | Hook shaft bushing(left)         | 1 | 1 | 1 |                 |
| C08      | HA300E2030 | Oil adjusting screw              | 1 | 1 | 1 |                 |
| C09      | HA100E2060 | Spring for oil adjusting         | 1 | 1 | 1 |                 |
| C10      | HA311E0671 | Hook shaft bushing(right)        | 1 | 1 | 1 |                 |
| C11      | HA100C2020 | Set screw                        | 1 | 1 | 1 | SM15/64(28)×10  |
| C12      | HA110E0672 | Oil pipe for hook shaft bushing  | 1 | 1 | 1 |                 |
| C13      | HA300E2100 | Plunger                          | 1 | 1 | 1 |                 |
| C14      | HA300E2110 | Plunger spring                   | 1 | 1 | 1 |                 |
| C15      | HA100E2100 | Guide plate                      | 1 |   |   |                 |
| C15      | HA300E2040 | Guide plate                      |   | 1 |   |                 |
| C15      | HA600E2020 | Guide plate                      |   |   | 1 |                 |
| C16      | HA104F0654 | Set screw                        | 1 | 1 | 1 | SM15/64(28)×10  |
| C17      | HA115E0069 | Rotating hook complete           | 1 |   |   |                 |
| C17      | HA500E2030 | Rotating hook complete           |   | 1 |   |                 |
| C17      | HA600E2070 | Rotating hook complete           |   |   | 1 |                 |
| C18      | HA300E2050 | Rotating hook positioner         | 1 |   |   |                 |
| C18      | HA500E2020 | Rotating hook positioner         |   | 1 |   |                 |
| C18      | HA600E2040 | Rotating hook positioner         |   |   | 1 |                 |
| C19      | HA100E2150 | Screw                            | 1 | 1 | 1 | SM11/64(40)×10  |
| C20      | HA119E0070 | Bobbin case                      | 1 |   |   |                 |
| C20      | HA300E2070 | Bobbin case                      |   | 1 |   |                 |
| C20      | HA608E0067 | Bobbin case                      |   |   | 1 |                 |
| C21      | HA100E2170 | Bobbin                           | 1 | 1 |   |                 |
| C21      | HA600E2060 | Bobbin                           |   |   | 1 |                 |
| C22      | HA104G0011 | Feed rock shaft crank            | 1 | 1 | 1 |                 |
| C23      | HA104G0012 | Screw                            | 2 | 2 | 2 |                 |
| C24      | HA104G0656 | Washer                           | 1 | 1 | 1 |                 |
| C25      | HA705J0654 | Shaft for feed bar(eccentric)    | 1 | 1 | 1 |                 |
| C26      | HA100C2190 | Screw                            | 1 | 1 | 1 |                 |
| C27      | HA7131J105 | Feed bar                         | 1 | 1 | 1 |                 |
| C28      | HA104G0653 | Feed dog                         | 1 | 1 | 1 |                 |
| C29      | HA104G0654 | Screw                            | 2 | 2 | 2 |                 |
| C30      | HA300G2050 | Feed rock shaft                  | 1 | 1 | 1 |                 |
| C31      | H007009150 | Stop ring                        | 1 | 1 | 1 | 15              |
| C32      | HA100G2040 | Feed rock shaft bushing          | 1 | 1 | 1 |                 |

## C.FEEDING AND FEED LIFTING & LOWER SHAFT MECHANISM

| Fig. No. | Part No.   | Description                          | M | H | B | Remarks        |
|----------|------------|--------------------------------------|---|---|---|----------------|
| C33      | HA305E0662 | Set screw                            | 1 | 1 | 1 |                |
| C34      | HA108G0661 | Collar                               | 1 | 1 | 1 |                |
| C35      | HA105D0662 | Set screw                            | 2 | 2 | 2 |                |
| C36      | HA7311C706 | Feed rock shaft crank(right)         | 1 |   |   |                |
| C36      | HA8211C205 | Feed rock shaft crank(right)         |   | 1 | 1 |                |
| C37      | HA7311C606 | Screw                                | 1 | 1 | 1 |                |
| C38      | HA706C11B1 | Feed rock shaft crank pin            | 1 | 1 | 1 |                |
| C39      | HA7311C806 | Screw                                | 1 | 1 | 1 |                |
| C40      | HA704K0652 | Feed lifting rock shaft              | 1 | 1 | 1 |                |
| C41      | H007009150 | Stop ring                            | 1 | 1 | 1 | 15             |
| C42      | HA100G2120 | Feed lifting rock shaft bushing      | 1 | 1 | 1 |                |
| C43      | HA100C2020 | Set screw                            | 1 | 1 | 1 | SM15/64(28)×10 |
| C44      | HA100G2130 | Washer                               | 1 | 1 | 1 |                |
| C45      | HA108G0661 | Collar for feed lifting rock shaft   | 1 | 1 | 1 |                |
| C46      | HA105D0662 | Set screw                            | 2 | 2 | 2 | SM1/4(40)×4    |
| C47      | HA7111K104 | Feed lifting rock shaft crank(left)  | 1 | 1 | 1 |                |
| C48      | HA111G0683 | Screw                                | 1 | 1 | 1 |                |
| C49      | HA705K0661 | Feed lifting rock shaft crank(right) | 1 |   |   |                |
| C49      | HA306G0671 | Feed lifting rock shaft crank(right) |   | 1 | 1 |                |
| C50      | HA104G0012 | Screw                                | 2 | 2 | 2 | SM3/16(28)×12  |
| C51      | HA100G2070 | Hinge pin                            | 1 | 1 | 1 |                |

# D.STITCH REGULATOR MECHANISM

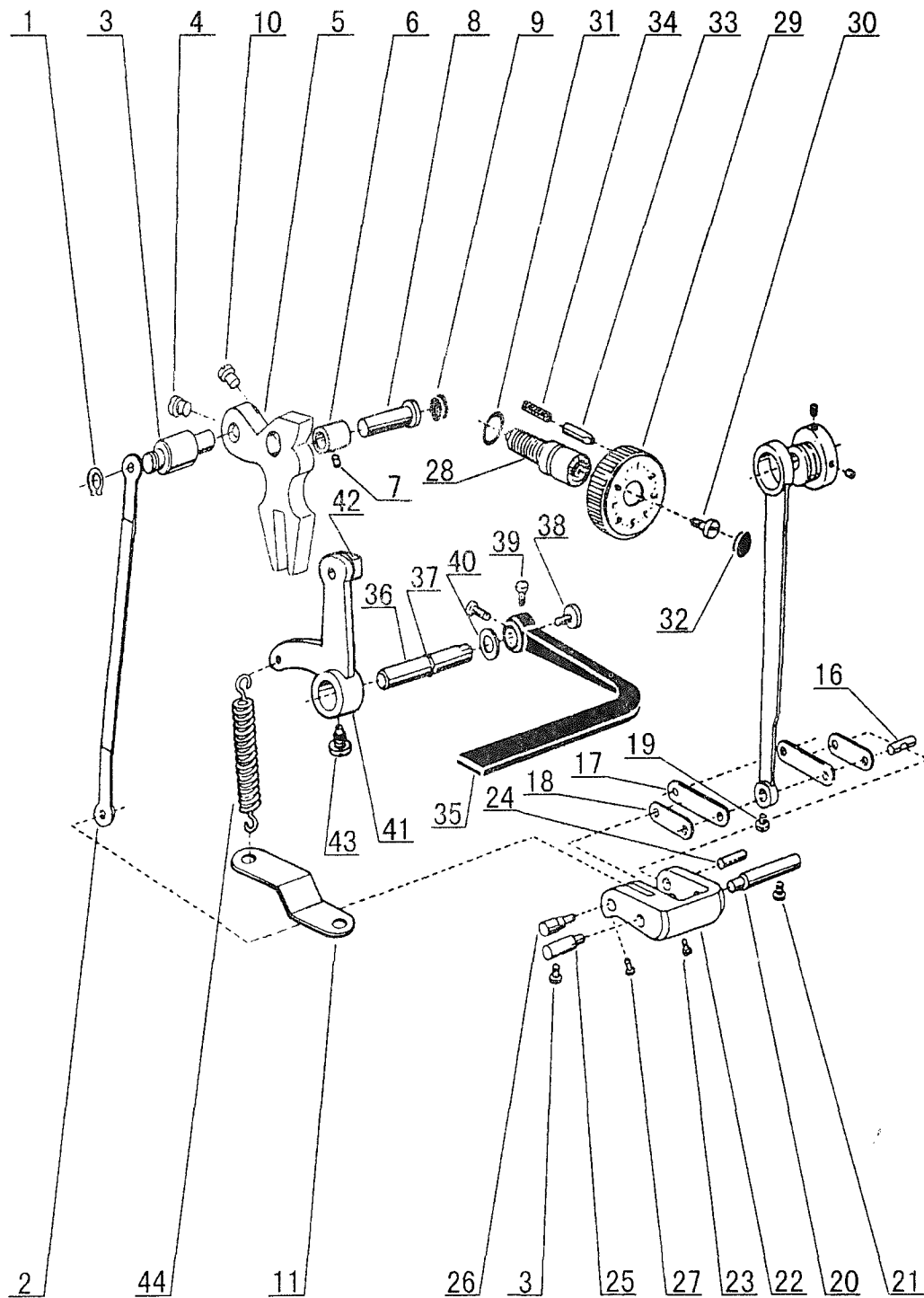

## D.STITCH REGULATOR MECHANISM

| Fig. No. | Part No.   | Description                   | M | H | B | Remarks        |
|----------|------------|-------------------------------|---|---|---|----------------|
| D01      | H007013050 | Stop ring                     | 1 | 1 | 1 | 5              |
| D02      | HA7311C406 | Feed connecting link          | 1 | 1 | 1 |                |
| D03      | H1204E0652 | Hinge pin                     | 1 | 1 | 1 |                |
| D04      | HA100C2190 | Set screw                     | 1 | 1 | 1 |                |
| D05      | H1204E0651 | Feed regulator cam            | 1 |   |   |                |
| D05      | H1404E0651 | Feed regulator cam            |   | 1 | 1 |                |
| D06      | HA704B0655 | Feed regulator bushing        | 1 | 1 | 1 |                |
| D07      | HA100C2020 | Screw                         | 1 | 1 | 1 |                |
| D08      | HA100F2040 | Hinge pin for feed regulator  | 1 | 1 | 1 |                |
| D09      | HA700B2120 | Rubber plug(Φ20×6)            | 1 | 1 | 1 |                |
| D10      | HA104F0654 | Screw                         | 1 | 1 | 1 |                |
| D11      | HA100F2140 | Spring retainer               | 1 | 1 | 1 |                |
| D16      | HA706C11B2 | Link stud                     | 1 | 1 | 1 |                |
| D17      | HA706C1192 | Link(long)                    | 2 |   |   |                |
| D17      | HA8211C305 | Link(long)                    |   | 2 | 2 |                |
| D18      | HA706C1191 | Link(short)                   | 2 | 2 | 2 |                |
| D19      | HA7311C806 | Set screw                     | 1 | 1 | 1 |                |
| D20      | HA700C2040 | Feed regulator shaft(right)   | 1 | 1 | 1 |                |
| D21      | HA111G0683 | Set screw                     | 1 | 1 | 1 |                |
| D22      | HA7311CG06 | Stitch length adjusting crank | 1 | 1 | 1 |                |
| D23      | HA7311CD06 | Set screw                     | 1 | 1 | 1 | SM9/64(40)×8.5 |
| D24      | HA7311CE06 | Link stud                     | 1 | 1 | 1 |                |
| D25      | HA700C2050 | Feed regulator shaft(left)    | 1 | 1 | 1 |                |
| D26      | HA7311CF06 | Link stud                     | 1 | 1 | 1 |                |
| D27      | HA7311CC06 | Screw                         | 1 | 1 | 1 |                |
| D28      | HA109F0671 | Feed regulator screw bar      | 1 | 1 | 1 |                |
| D29      | HA307F0661 | Dial                          | 1 |   |   |                |
| D29      | HA506F0672 | Dial                          |   | 1 |   |                |
| D29      | H2004F0066 | Dial                          |   |   | 1 |                |
| D30      | HA109F0673 | Screw                         | 1 | 1 | 1 | SM3/16(28)×8   |
| D31      | HA109F0674 | O-ring                        | 1 | 1 | 1 |                |
| D32      | HA300F2050 | Rubber plug                   | 1 | 1 | 1 |                |
| D33      | HA100F2080 | Stopper pin                   | 1 | 1 | 1 |                |
| D34      | HA100F2090 | Spring for stopper pin        | 1 | 1 | 1 |                |
| D35      | HA309F0671 | Reverse feed lever            | 1 | 1 | 1 |                |
| D36      | HA113F3021 | Reverse feed lever pin        | 1 | 1 | 1 |                |
| D37      | HA113F3022 | O-ring                        | 1 | 1 | 1 |                |
| D38      | HA113F0683 | Screw                         | 1 | 1 | 1 | SM3/16(28)×6.5 |
| D39      | HA104F0654 | Screw                         | 2 | 2 | 2 | SM15/64(28)×10 |
| D40      | HA100F2110 | Washer                        | 1 | 1 | 1 |                |
| D41      | HA115F0691 | Reverse feed lever crank      | 1 | 1 | 1 |                |
| D42      | HA115F4011 | Reverse feed lever crank pin  | 1 | 1 | 1 |                |
| D43      | HA100F2130 | Screw                         | 1 | 1 | 1 |                |



# D.STITCH REGULATOR MECHANISM

| Fig. No. | Part No.   | Description                     | M | H | B | Remarks |
|----------|------------|---------------------------------|---|---|---|---------|
| D44      | HA115F0692 | Spring for feed regulator crank | 1 | 1 | 1 |         |

# E.PRESSER FOOT MECHANISM

---

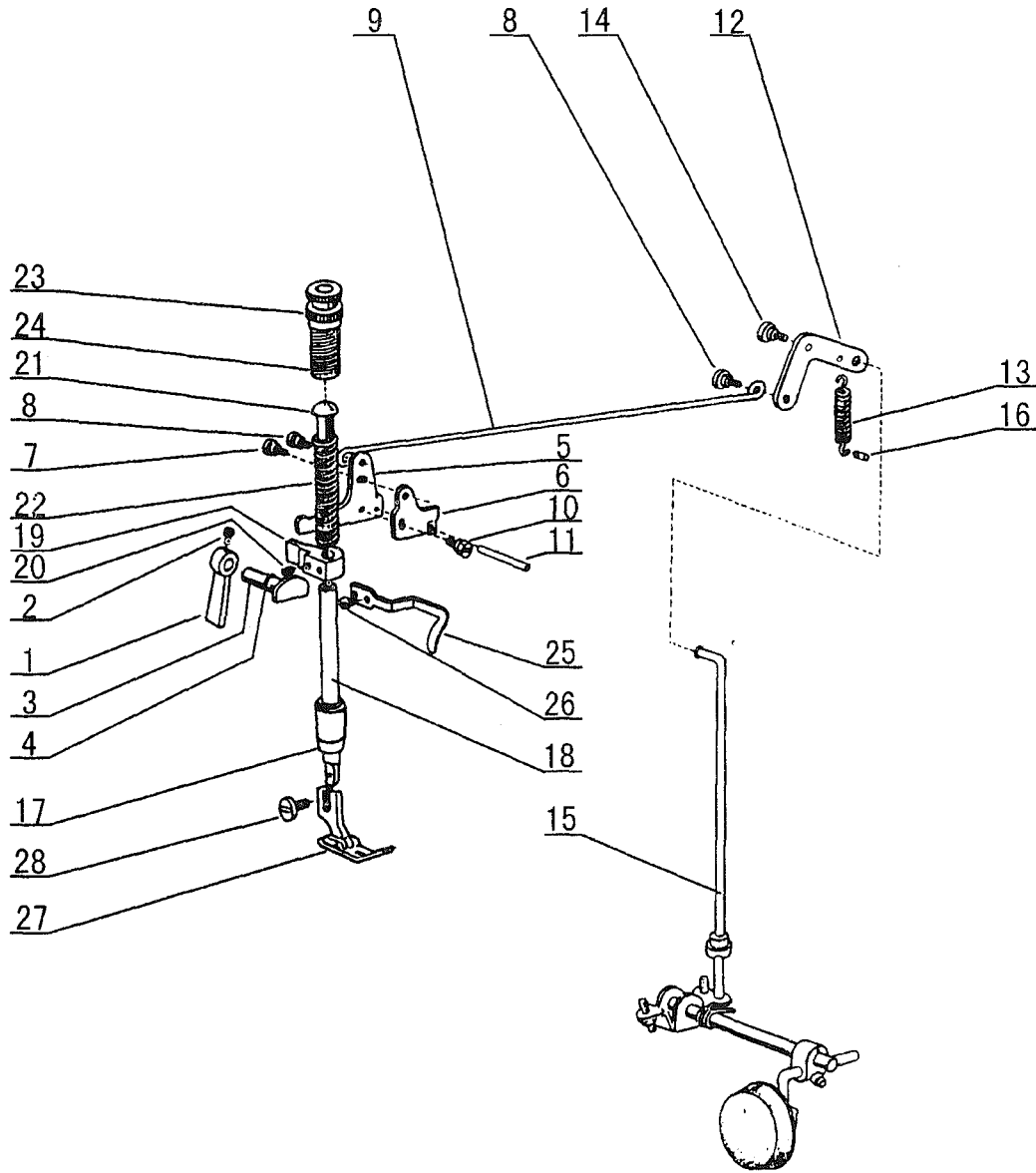

## E.PRESSER FOOT MECHANISM

| Fig. No. | Part No.   | Description                     | M | H | B | Remarks            |
|----------|------------|---------------------------------|---|---|---|--------------------|
| E01      | H1204F0651 | Presser bar lifter              | 1 | 1 | 1 |                    |
| E02      | HA300B2170 | Set screw                       | 1 | 1 | 1 | SM11/64(40)×5.5    |
| E03      | H1205F0661 | Presser bar lifter cam          | 1 | 1 | 1 |                    |
| E04      | HA300H2080 | O-ring                          | 1 | 1 | 1 |                    |
| E05      | HA107H1011 | Knee lifter lever(left)         | 1 | 1 | 1 |                    |
| E06      | HA305H6611 | Tension releasing cam           | 1 | 1 | 1 |                    |
| E07      | HA107H1013 | Screw                           | 1 | 1 | 1 | SM11/64(40)×6.5    |
| E08      | HA107H0662 | Screw                           | 2 | 2 | 2 | SM3/16(28)×3.5     |
| E09      | HA107H0663 | Knee lifter rod                 | 1 | 1 | 1 |                    |
| E10      | HA100H2050 | Screw                           | 1 | 1 | 1 | SM15/64(28) × 13.5 |
| E11      | HA100H2060 | Tension releasing pin           | 1 | 1 | 1 |                    |
| E12      | HA110H0671 | Knee lifter lever(right)        | 1 | 1 | 1 |                    |
| E13      | HA110H0672 | Spring for knee lifter lever    | 1 | 1 | 1 |                    |
| E14      | HA100H2050 | Screw                           | 1 | 1 | 1 | SM15/64(28)×13.5   |
| E15      | HA306H0671 | Knee lifter connecting rod      | 1 | 1 | 1 |                    |
| E16      | HA100H2080 | Pin for spring                  | 1 | 1 | 1 |                    |
| E17      | HA300H2090 | Presser bar bushing             | 1 | 1 | 1 |                    |
| E18      | HA300H2110 | Presser bar                     | 1 | 1 | 1 |                    |
| E19      | HA307H0671 | Presser bar lifting bracket     | 1 | 1 | 1 |                    |
| E20      | HA3411D308 | Screw                           | 1 | 1 | 1 | SM15/64(28)×7      |
| E21      | HA100H2120 | Presser bar spring guide        | 1 | 1 | 1 |                    |
| E22      | HA100H2130 | Presser bar spring              | 1 | 1 | 1 |                    |
| E23      | HA117H0692 | Lock nut                        | 1 | 1 | 1 |                    |
| E24      | HA309H0681 | Pressure regulating thumb screw | 1 | 1 | 1 |                    |
| E25      | HA300H2120 | Upper thread guide              | 1 | 1 | 1 |                    |
| E26      | HA100C2040 | Set screw                       | 1 | 1 | 1 | SM11/64(40)×5.5    |
| E27      | HA310H0069 | Presser foot complete           | 1 | 1 |   |                    |
| E27      | HA106H0066 | Presser foot complete           |   |   | 1 |                    |
| E28      | HA100H2150 | Screw                           | 1 | 1 | 1 | SM9/64(40)×11      |

# F.OIL LUBRICATION MECHANISM

---

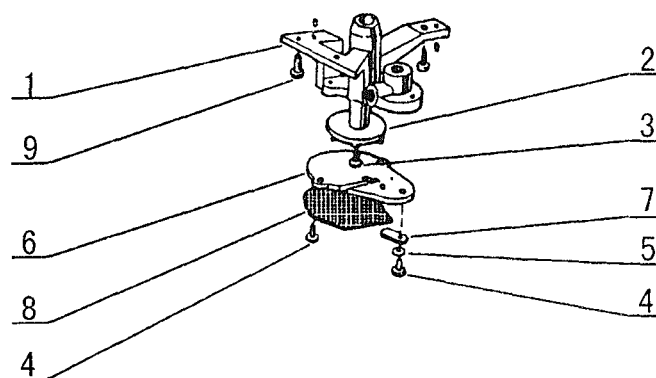
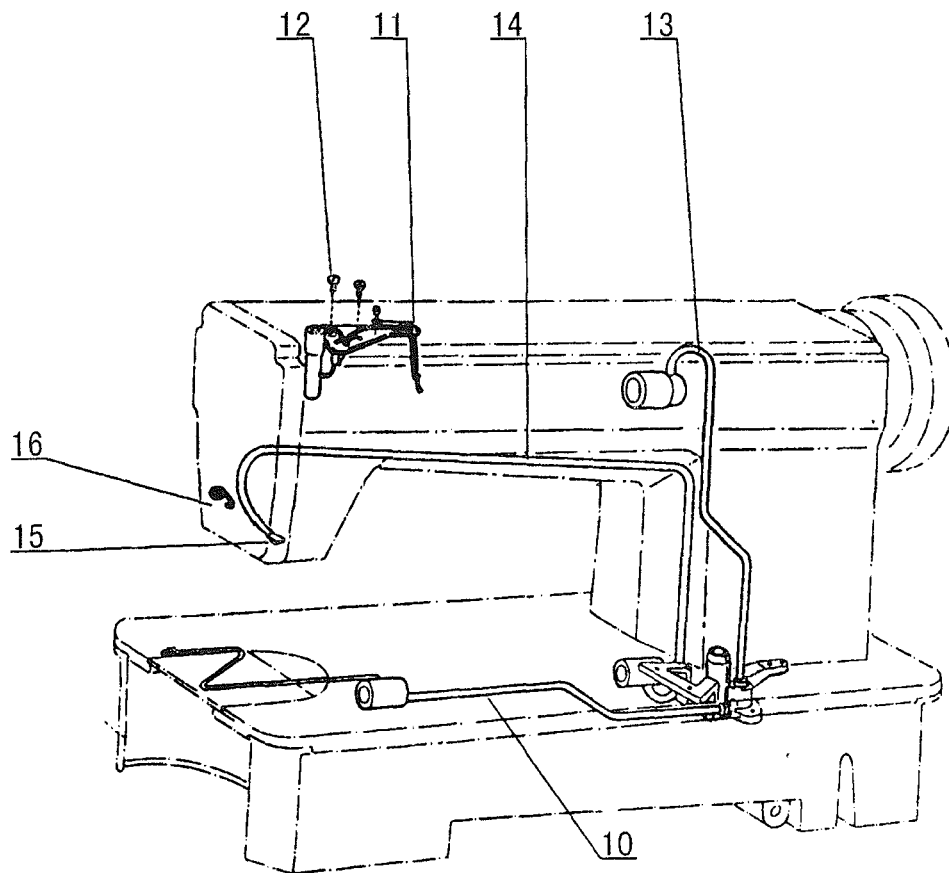

# F.OIL LUBRICATION MECHANISM

| Fig. No. | Part No.   | Description              | M | H | B | Remarks        |
|----------|------------|--------------------------|---|---|---|----------------|
| F01      | HA100I2010 | Oil pump body            | 1 | 1 | 1 |                |
| F02      | HA100I2020 | Oil pump impeller        | 1 | 1 | 1 |                |
| F03      | HA100I2030 | Screw                    | 1 | 1 | 1 | SM1/8(44)×6.5  |
| F04      | HA300I2050 | Screw                    | 3 | 3 | 3 | SM1/8(44)×13   |
| F05      | HA100I2050 | Spring washer            | 1 | 1 | 1 |                |
| F06      | HA100I2060 | Oil pump fitting plate   | 1 | 1 | 1 |                |
| F07      | HA100I2070 | Oil adjusting plate      | 1 | 1 | 1 |                |
| F08      | HA111I0065 | Oil pump screen complete | 1 | 1 | 1 |                |
| F09      | HA100I2090 | Screw                    | 3 | 3 | 3 | SM11/64(40)×13 |
| F10      | HA113I0066 | Oil pipe for hook shaft  | 1 | 1 | 1 |                |
| F11      | HA304I0065 | Oil braid fitting plate  | 1 |   |   |                |
| F11      | HA504I0065 | Oil braid fitting plate  |   | 1 | 1 |                |
| F12      | HA100H2150 | Screw                    | 2 | 2 | 2 |                |
| F13      | HA116I0068 | Oil pipe for arm shaft   | 1 |   |   |                |
| F13      | H5604G0065 | Oil pipe for arm shaft   |   | 1 | 1 |                |
| F14      | HA305I0661 | Oil return pipe          | 1 | 1 | 1 |                |
| F15      | HA100I2150 | Felt pouch               | 1 | 1 | 1 |                |
| F16      | HA300I2060 | Piper holder             | 1 | 1 | 1 |                |

# G.ACCESSORIES

---

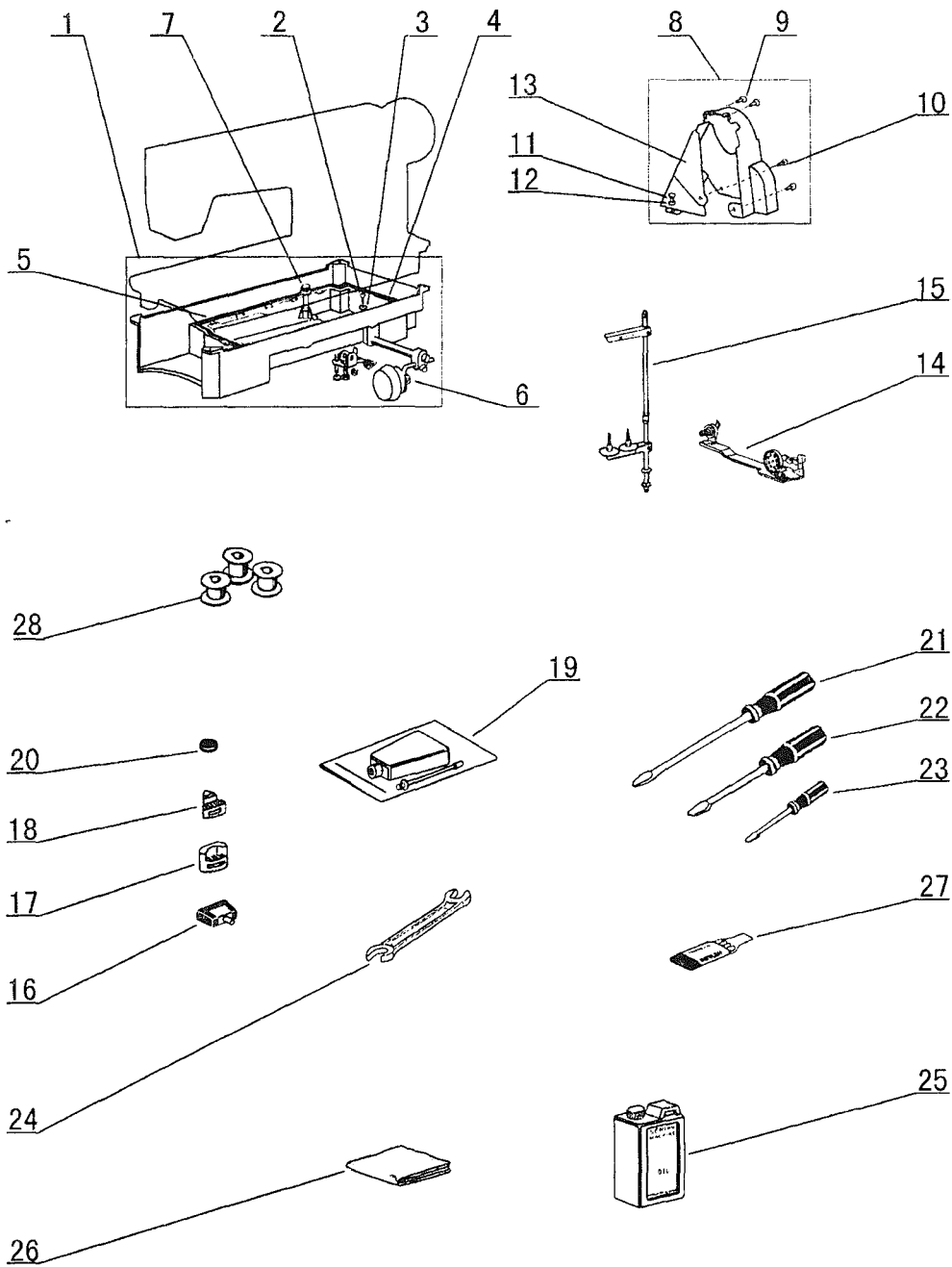

# G.ACCESSORIES

| Fig. No. | Part No.   | Description                     | M | H | B | Remarks       |
|----------|------------|---------------------------------|---|---|---|---------------|
| G01      | HA304J0065 | Oil reservoir                   | 1 | 1 | 1 |               |
| G02      | HA104J0652 | Oil drain screw                 | 1 | 1 | 1 | SM5/16(28)×10 |
| G03      | HA104J0653 | Washer                          | 1 | 1 | 1 |               |
| G04      | HA104J0654 | Gasket for oil reservoir(small) | 1 | 1 | 1 |               |
| G05      | HA104J0655 | Gasket for oil reservoir(large) | 1 | 1 | 1 |               |
| G06      | HA106J0066 | Knee lifter complete            | 1 | 1 | 1 |               |
| G07      | HA106J0661 | Knee lifter lifting rod         | 1 | 1 | 1 |               |
| G08      | HA305J0066 | Belt cover complete             | 1 | 1 | 1 |               |
| G09      | HA300B2170 | Screw                           | 2 | 2 | 2 | SM11/64(40)×9 |
| G10      | HA300J2280 | Screw                           | 2 | 2 | 2 | SM15/64(28)×8 |
| G11      | H801045200 | Screw                           | 4 | 4 | 4 | 4.5×20        |
| G12      | HA300J2230 | Washer                          | 2 | 2 | 2 |               |
| G13      | HA305J0663 | Belt cover                      | 1 |   |   |               |
| G13      | HA305J0665 | Belt cover                      |   | 1 |   |               |
| G13      | H2008O0070 | Belt cover plate complete       |   |   | 1 |               |
| G14      | HA109J0068 | Bobbin winder assy.             | 1 | 1 |   |               |
| G14      | HA905S0066 | Bobbin winder assy.             |   |   | 1 |               |
| G15      | HA200J2030 | Thread stand assy.              | 1 | 1 | 1 |               |
| G16      | HA307J0067 | Table hinge with rubber cushion | 1 | 1 | 1 |               |
| G17      | HA300J2050 | Vibration preventing rubber     | 2 | 2 | 2 |               |
| G18      | HA300J2060 | Vibration preventing rubber     | 2 | 2 | 2 |               |
| G19      | HA100J2110 | Oil with oiler                  | 1 | 1 | 1 |               |
| G20      | HA100J2120 | Magnet block for reservoir      | 1 | 1 | 1 |               |
| G21      | HA300J2070 | Screw driver(large)             | 1 | 1 | 1 |               |
| G22      | HA300J2200 | Screw driver(middle)            | 1 | 1 | 1 |               |
| G23      | HA300J2210 | Screw driver(small)             | 1 | 1 | 1 |               |
| G24      | HA300J2220 | Double-ended spanner            | 1 | 1 | 1 |               |
| G25      | HA300J2170 | Oil box                         | 1 | 1 | 1 |               |
| G26      | HA100J2180 | Cover                           | 1 | 1 | 1 |               |
| G27      | HA100C2160 | Needle                          | 4 |   |   | DB×1 14#      |
| G27      | H1000C2010 | Needle                          |   | 4 |   | DP×5 18#      |
| G27      | HA500C2040 | Needle                          |   |   | 4 | DB×1 22#      |
| G28      | HA100E2170 | Bobbin                          | 3 | 3 |   |               |
| G28      | HA600E2060 | Bobbin                          |   |   | 3 |               |

**SHANGHAI HUIGONG NO.3 SEWING MACHINE FACTORY**

**ADD: 1418, Yishan Road, Shanghai, China**

**Zip Code: 201103**

**Overseas Business: TEL: 86-21-64853303 FAX: 86-21-64854304**

**E-mail: [highlead@online.sh.cn](mailto:highlead@online.sh.cn) <http://www.highlead.com.cn>**

The description covered in this manual is subject to change for improvement of the commodity without notice

2004.3. Printed