

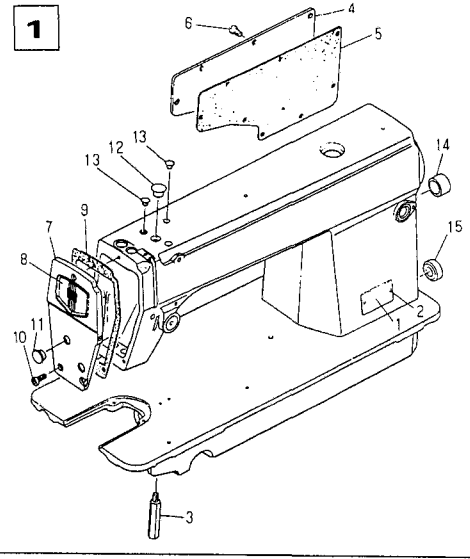

**High Speed Single Needle Lockstitch Industrial Sewing Machine**  
**GC1088 Series**  
**Parts List**



**1. Arm bed components**

Ref. No.	Part No.	Description	Amt.
1	H110-01-001	Model plate	1
2	H110-01-002	Model plate rivet	2
3	H110-01-003	Bed screw stud	4
4	H110-01-004	Side plate	1
5	H110-01-005	Gasket	1
6	H110-01-006	Screw 12/64-28 L=9	8
7	H110-01-007	Face plate arm	1
8	H110-01-008	Decorative plate	1
9	H110-01-009	Gasket	1
10	H110-01-010	Screw	3
11	H110-01-011	Rubber plug	2
12	H110-01-012	Rubber plug	1
13	H110-01-013	Rubber plug	2
14	H110-01-014	Rubber plug	1
15	H110-01-015	Rubber plug	1

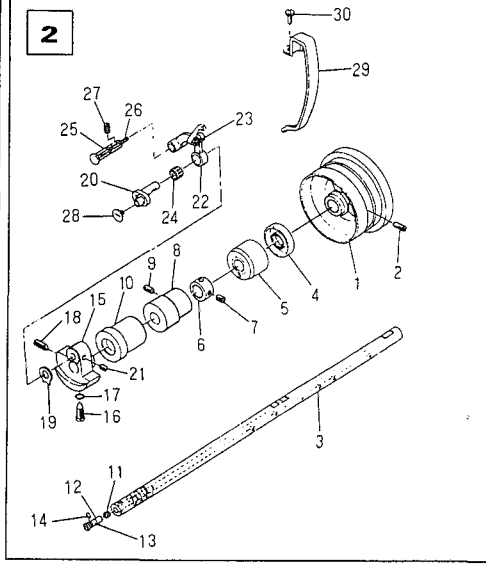

**2. Main shaft & thread take-up components**

Ref. No.	Part No.	Description	Amt.
1	H110-02-001	Hand wheel	1
2	H110-02-002	Screw 15/64-28 L=15	2
3	H110-02-003	Main shaft	1
4	H110-02-004	Oil seal	1
5	H110-02-005	Main shaft bushing, rear	1
6	H110-02-006	Thrust collar asm.	1
7	H110-02-007	Screw 1/4-40 L=6	2
8	H110-02-008	Bushing, intermediate	1
9	H110-02-009	Screw	1
10	H110-02-010	Main shaft bushing, front	1
11	H110-02-011	Roller felt	1
12	H110-02-012	Oil amount adjusting pin asm.	1
13	H110-02-013	Rubber bushing	1
14	H110-02-014	Rubber ring	1
15	H110-02-015	Counterweight	1
16	H110-02-016	Screw 1/4-40 L=6	1
17	H110-02-017	Rubber ring	1
18	H110-02-018	Screw 9/32-28 L=16	1
19	H110-02-019	Counterweight protecting plate	1
20	H110-02-020	Needle bar crank asm.	1
21	H110-02-021	Screw 1/4-40 L=6	2
22	H110-02-022	Thread take-up lever asm.	1
23	H110-02-023	Rubber	1
24	H110-02-024	Needle bearing	1
25	H110-02-025	Thread take-up crank shaft	1
26	H110-02-026	Oiling wick	1
27	H110-02-027	Screw 15/64-28 L=10.5	1
28	H110-02-028	Screw(left twist) 9/64-40 L=4	1
29	H110-02-029	Thread take-up lever cover	1
30	H110-02-030	Screw 3/16-28 L=6	1

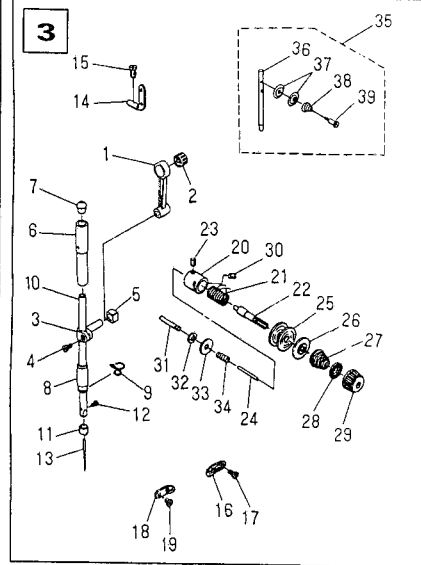

**3. Needle bar & thread tension components**

Ref. No.	Part No.	Description
1	H110-03-001	Needle bar crank rod
2	H110-03-002	Needle bearing
3	H110-03-003	Needle bar connection asm.
4	H110-03-004	Screw 9/64-40 L=6
5	H110-03-005	Slide block
6	H110-03-006	Needle bar bushing, upper
7	H110-03-007	Cap
8	H110-03-008	Needle bar bushing, lower
9	H110-03-009	Needle bar thread guide
10	H110-03-010	Needle bar
11	H110-03-011	Needle bar thread guide
12	H110-03-012	Screw 1/8-44 L=4.5
13	H110-03-013	Needle (DBx1 #14)
14	H110-03-014	Two-hole thread eyelet
15	H110-03-015	Screw 3/16-28 L=6
16	H110-03-016	Frame thread guide, right
17	H110-03-017	Screw 11/64-40 L=6
18	H110-03-018	Frame thread guide, left
19	H110-03-019	Screw 11/64-40 L=6
20	H110-03-020	Tension post socket
21	H110-03-021	Take-up spring
22	H110-03-022	Screw
23	H110-03-023	Set screw 9/64-40 L=5.5
24	H110-03-024	Thread release pin
25	H110-03-025	Tension disc
26	H110-03-026	Tension disc holder
27	H110-03-027	Tension spring
28	H110-03-028	Tension disc stopper
29	H110-03-029	Tension nut
30	H110-03-030	Screw 15/64-28 L=7
31	H110-03-031	Tension release supporting pin
32	H110-03-032	Snap ring
33	H110-03-033	Washer plate
34	H110-03-034	Tension release pin spring
35	H110-03-035	Needle thread guide pin asm.
36	H110-03-036	Needle thread guide pin
37	H110-03-037	Tension disc
38	H110-03-038	Tension spring
39	H110-03-039	Hinge screw

SHANGHAI HUIGONG SEWING MACHINE NO.3 FACTORY

ADD: 1418, Yishan Road, Shanghai, China

Zip Code: 201103 TEL: (021)64061284 64852138

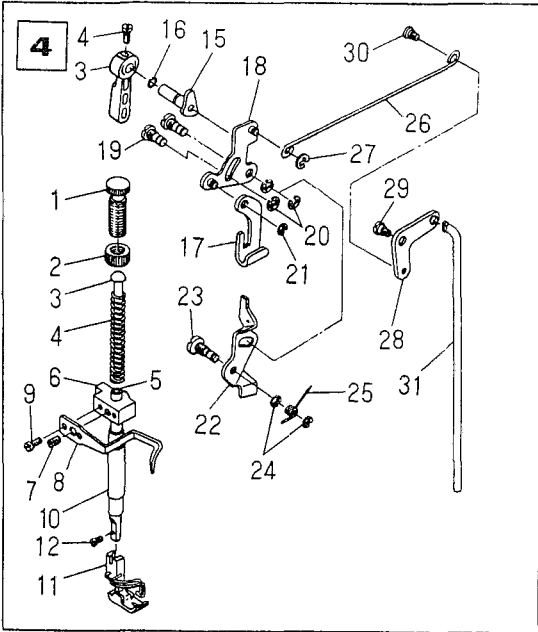

4. Presser bar components

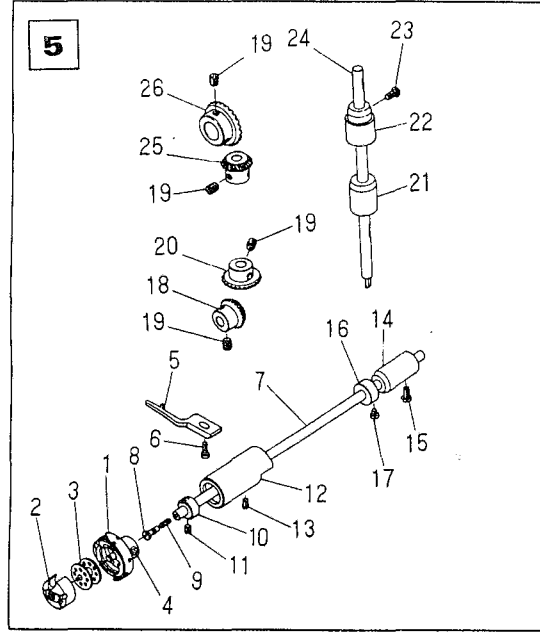

5. Hook driving shaft components

Ref. No.	Part No.	Description	Amt.
1	H110-04-001	Presser spring regulator	1
2	H110-04-002	Nut	1
3	H110-04-003	Presser guide bar	1
4	H110-04-004	Presser spring	1
5	H110-04-005	Presser bar	1
6	H110-04-006	Needle bar guide bracket	1
7	H110-04-007	Screw 1/4-40 L=8	1
8	H110-04-008	Presser bar thread guide	1
9	H110-04-009	Screw 9/64-40 L=8.5	2
10	H110-04-010	Presser bar bushing , lower	1
11	H110-04-011	Presser foot asm.	1
12	H110-04-012	Screw 9/64-40 L=10.5	1
13	H110-04-013	Hand lifter	1
14	H110-04-014	Screw	1
15	H110-04-015	Hand lifter cam asm.	1
16	H110-04-016	Rubber ring	1
17	H110-04-017	Lifting lever	1
18	H110-04-018	Hand lifter link asm.	1
19	H110-04-019	Link shaft	2
20	H110-04-020	Snap ring	3
21	H110-04-021	Lifting lever ring	1
22	H110-04-022	Tension release plate	1
23	H110-04-023	Tension release shaft	1
24	H110-04-024	Snap ring	2
25	H110-04-025	Tension release return spring	1
26	H110-04-026	Lifting lever connecting rod	1
27	H110-04-027	Snap ring	1
28	H110-04-028	Lifting lever link	1
29	H110-04-029	Hinge screw	1
30	H110-04-030	Hinge screw	1
31	H110-04-031	Connecting rod vertical	1

Ref. No.	Part No.	Description	Amt.
1	H110-05-001	Hook asm.	1
2	H110-05-002	Bobbin case asm.	1
3	H110-05-003	Bobbin	1
4	H110-05-004	Screw	2
5	H110-05-005	Positioning finger	1
6	H110-05-006	Screw 11/64-40 L=9.5	1
7	H110-05-007	Hook driving shaft	1
8	H110-05-008	Oil seal screw	1
9	H110-05-009	Oil wick	1
10	H110-05-010	Thrust collar	1
11	H110-05-011	Screw 11/64-40 L=3.5	2
12	H110-05-012	Bushing asm.front	1
13	H110-05-013	Screw	1
14	H110-05-014	Bushing , rear	1
15	H110-05-015	Screw	1
16	H110-05-016	Thrust collar asm.	1
17	H110-05-017	Screw 11/64-40 L=4.8	2
18	H110-05-018	Pinion asm.	1
19	H110-05-019	Screw 1/4-40 L=8	8
20	H110-05-020	Gear asm.large	1
21	H110-05-021	Upright shaft bushing , lower	1
22	H110-05-022	Bushing , upper	1
23	H110-05-023	Screw	1
24	H110-05-024	Upright shaft	1
25	H110-05-025	Pinion asm.	1
26	H110-05-026	Gear asm.	1

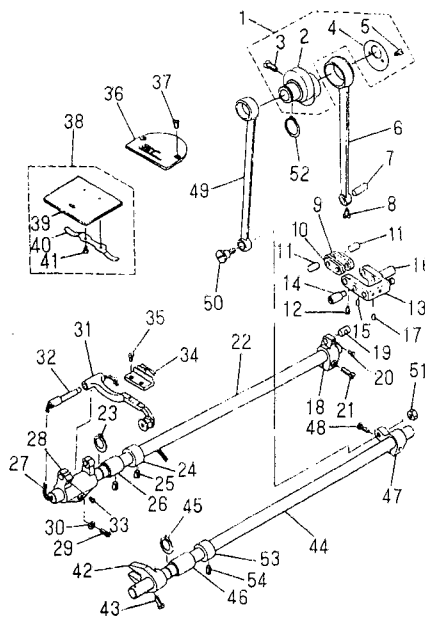

## Feed mechanism components

f. No.	Part No.	Description	Amt.	Ref. No.	Part No.	Description	Amt.
1	H110-06-001	Feed drive eccentric cam asm.	1	35	H110-06-035	Screw 1/8-44 L=6	2
2	H110-06-002	Feed drive eccentric cam	(1)	36	H110-06-036	Throat plate	1
3	H110-06-003	Screw 1/4-40 L=11	(2)	37	H110-06-037	Screw 11/64-40 L=8.5	2
4	H110-06-004	Thrust collar	(1)	38	H110-06-038	Bed slide asm.	1
5	H110-06-005	Screw 9/64-40 L=6	(2)	39	H110-06-039	Slide plate	(1)
6	H110-06-006	Rocker shaft connecting rod	1	40	H110-06-040	Bed slide spring	(1)
7	H110-06-007	Walking foot pin	1	41	H110-06-041	Screw 3/32-56 L=1.9	(2)
8	H110-06-008	Screw 9/64-40 L=6	1	42	H110-06-042	Driving shaft crank asm. Front	1
9	H110-06-009	Walking foot link	2	43	H110-06-043	Screw 11/64-40 L=10.5	1
10	H110-06-010	Connecting link	2	44	H110-06-044	Feed driving shaft	1
11	H110-06-011	Walking foot pin	2	45	H110-06-045	Retaining ring	1
12	H110-06-012	Screw 9/64-40 L=6	2	46	H110-06-046	Feed rocker shaft bushing	1
13	H110-06-013	Walking foot adjusting link	1	47	H110-06-047	Rear crank asm.	1
14	H110-06-014	Adjusting link fulcrum shaft	1	48	H110-06-048	Screw 3/16-28 L=12	1
15	H110-06-015	Screw 15/64-28 L=7	1	49	H110-06-049	Connecting rod	1
16	H110-06-016	Adjusting link fulcrum shaft	1	50	H110-06-050	Hinge Screw	1
17	H110-06-017	Screw 15/64-28 L=7	1	51	H110-06-051	Nut 9/32-28	1
18	H110-06-018	Feed rocker shaft crank asm.	1	52	H110-06-052	Snap ring	1
19	H110-06-019	Walking foot pin	1	53	H110-06-053	Thrust collar asm.	1
20	H110-06-020	Screw 9/64-40 L=6	1	54	H110-06-054	Screw 1/4-40 L=6	2
21	H110-06-021	Screw 3/16-28 L=14	1				
22	H110-06-022	Feed rocker shaft	1				
23	H110-06-023	Retaining ring	1				
24	H110-06-024	Thrust collar asm.	1				
25	H110-06-025	Screw 1/4 40 L=6	2				
26	H110-06-026	Feed rocker shaft bushing	1				
27	H110-06-027	Oil wick	1				
28	H110-06-028	Feed rocker asm.	1				
29	H110-06-029	Screw 3/16-28 L=14	1				
30	H110-06-030	Washer	1				
31	H110-06-031	Feed bar asm.	1				
32	H110-06-032	Feed bar shaft	1				
33	H110-06-033	Screw 11/64-40 L=7	1				
34	H110-06-034	Feed dog	1				

7

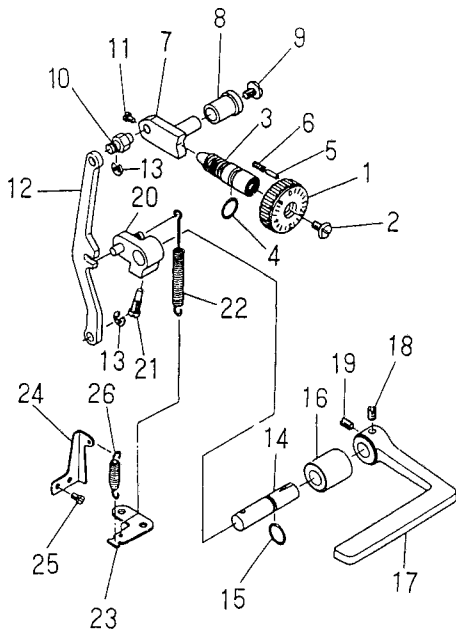

7. Feed regulating components

Ref. No.	Part No.	Description	Amt.
1	H110-07-001	Feed dial	1
2	H110-07-002	Screw	1
3	H110-07-003	Feed regulator screw	1
4	H110-07-004	Rubber ring	1
5	H110-07-005	Pin	1
6	H110-07-006	Spring	1
7	H110-07-007	Feed regulator	1
8	H110-07-008	Feed regulator bushing	1
9	H110-07-009	Screw	1
10	H110-07-010	Feed regulator pin	1
11	H110-07-011	Screw 9/64-40 L=6	2
12	H110-07-012	Feed regulator connecting rod	1
13	H110-07-013	Snap ring	2
14	H110-07-014	Feed reverse shaft	1
15	H110-07-015	Rubber ring	1
16	H110-07-016	Feed lever metal	1
17	H110-07-017	Reverse feed control lever	1
18	H110-07-018	Screw 1/4-40 L=10	1
19	H110-07-019	Screw 1/4-40 L=8	1
20	H110-07-020	Feed reverse arm asm.	1
21	H110-07-021	Feed reverse arm screw	1
22	H110-07-022	Feed reverse spring	1
23	H110-07-023	Feed spring hook	1
24	H110-07-024	Adjusting link spring guide	1
25	H110-07-025	Screw 11/64-40 L=5	2
26	H110-07-026	Adjusting link spring	1

8

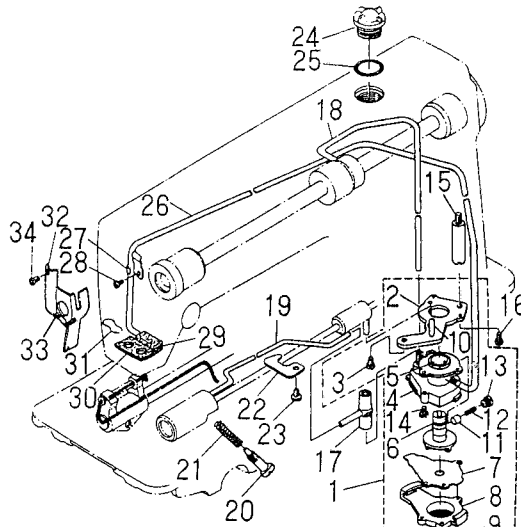

8. Lubrication components

Ref. No.	Part No.	Description	Amt.
1	H110-08-001	Lubricating oil pump asm.	1
2	H110-08-002	Oil pump installing base	(1)
3	H110-08-003	Screw 15/64-28 L=9	(3)
4	H110-08-004	Oil pump	(1)
5	H110-08-005	Oil pump bushing	(1)
6	H110-08-006	Oil pump impeller	(1)
7	H110-08-007	Oil pump impeller cover	(1)
8	H110-08-008	Lubricating oil pump cover	(1)
9	H110-08-009	Screw	(3)
10	H110-08-010	Hook driving shaft oil tube	(1)
11	H110-08-011	Plunger	(1)
12	H110-08-012	Plunger spring	(1)
13	H110-08-013	Plunger screw	(1)
14	H110-08-014	Screw	(1)
15	H110-08-015	Oil pump support	1
16	H110-08-016	Screw 11/64-40 L=9.5	1
17	H110-08-017	Rubber joint	1
18	H110-08-018	Main shaft oil tube	1
19	H110-08-019	Oil tube	1
20	H110-08-020	Oil adjusting screw	1
21	H110-08-021	Spring	1
22	H110-08-022	Tube holder(lower)	1
23	H110-08-023	Screw 15/64-28 L=9	1
24	H110-08-024	Oil sight window	1
25	H110-08-025	Rubber ring	1
26	H110-08-026	Oil return tube	1
27	H110-08-027	Oil return tube holder	1
28	H110-08-028	Screw 3/16-28 L=6	1
29	H110-08-029	Anti-dust oil felt	1
30	H110-08-030	Oil felt	1
31	H110-08-031	Oil felt presser	1
32	H110-08-032	Arm oil shield	1
33	H110-08-033	Oil wick	1
34	H110-08-034	Screw 1/8-44 L=4	1

9

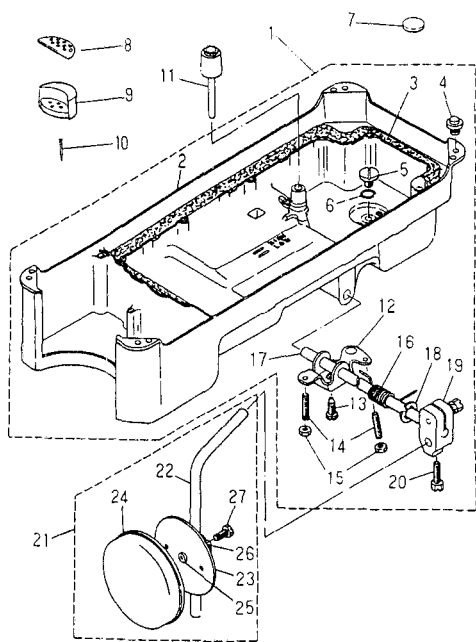

10-1

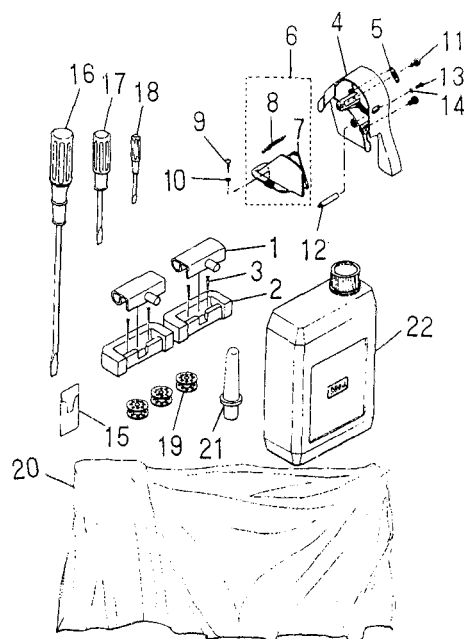

Oil reservoir & knee lifter components

10, Machine head accessories (1)

No.	Part No.	Description	Amt.
1	H110-09-001	Oil reservoir asm	1
2	H110-09-002	Oil reservoir	(1)
3	H110-09-003	Gasket	(1)
4	H110-09-004	Rubber cushion	(4)
5	H110-09-005	Screw	(2)
6	H110-09-006	Rubber ring	(2)
7	H110-09-007	Oil reservoir magnet	1
8	H110-09-008	Oil reservoir felt cushion	2
9	H110-09-009	Oil reservoir rubber cushion	2
10	H110-09-010	Nail	4
11	H110-09-011	Knee press lifter rod	1
12	H110-09-012	Connecting rod, vertical	1
13	H110-09-013	Screw	1
14	H110-09-014	Screw 15/64-28 L=30	2
15	H110-09-015	Nut 15/64-28	2
16	H110-09-016	Spring	1
17	H110-09-017	Knee press rod	1
18	H110-09-018	Snap ring	1
19	H110-09-019	Bearing bracket	1
20	H110-09-020	Screw 9/32-20 L=20	2
21	H110-09-021	Knee press plate asm.	1
22	H110-09-022	Knee lifter plate rod	1
23	H110-09-023	Knee press plate	1
24	H110-09-024	Knee press plate cover	1
25	H110-09-025	Rubber	1
26	H110-09-026	Knee press plate holder	1
27	H110-09-027	Screw 15/64-28 L=15	1

Ref. No.	Part No.	Description	Amt.
1	H110-10-001	Machine hinge plate asm.	2
2	H110-10-002	Machine hinge plate	2
3	H110-10-003	Nail	4
4	H110-10-004	Beltcover, A	1
5	H110-10-005	Beltcover, A cap	1
6	H110-10-006	Beltcover, B asm.	1
7	H110-10-007	Beltcover, B	1
8	H110-10-008	Beltcover, B cover asm.	1
9	H110-10-009	Wood screw D=4.5 L=20	2
10	H110-10-010	Washer	2
11	H110-10-011	Beltcover, A screw	2
12	H110-10-012	Beltcover support	1
13	H110-10-013	Screw 3/16-28 L=14	1
14	H110-10-014	Washer	1
15	H110-10-015	Needle	1
16	H110-10-016	Screw driver, large	1
17	H110-10-017	Screw driver, medium	1
18	H110-10-018	Screw driver, small	1
19	H110-10-019	Bobbin	3
20	H110-10-020	Machine head cover	1
21	H110-10-021	Machine rest pin	1
22	72T9-017	Oil reservoir asm.	1

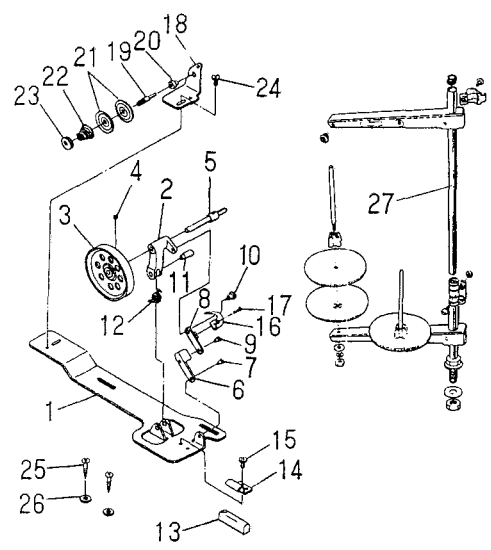

Model GC1088-A (For Light Weight Materials)

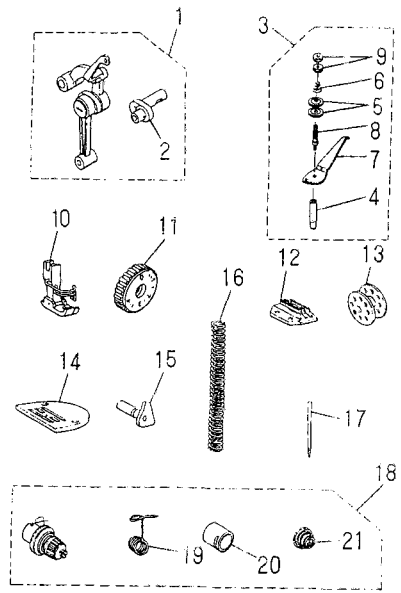

10. Machine head accessories (2)

Model GC1088-A (For Light Weight Materials)

M

Ref. No.	Part No.	Description	Amt.	Ref. No.	Part No.	Description	Amt.	Re
1	H110-11-001	Bobbin winder base asm.	1	1	H110-11-001	Link thread take-up lever asm.	1	
2	H110-11-002	Thread winder base asm.	1	2	H110-11-002	Needle bar crank A	(1)	
3	H110-11-003	Thread winder asm.	1	3	H110-11-003	Needle thread guide pin asm.	1	
4	H110-11-004	Screw	1	4	H110-11-004	Needle thread guide pin	(1)	
5	H110-11-005	Bobbin winder shaft	1	5	H110-11-005	Tension disc	(2)	
6	H110-11-006	Connecting rod	1	6	H110-11-006	Needle thread tension spring	(1)	
7	H110-11-007	Connecting rod pin	1	7	H110-11-007	Needle thread guide plate	(1)	
8	H110-11-008	Bobbin winder frame rod	1	8	H110-11-008	Needle thread guide pin	(1)	
9	H110-11-009	Bobbin winder frame rod pin	1	9	H110-11-009	Needle thread tension thumb nut	(2)	
10	H110-11-010	Screw 1/8-44 L=12.5	1	10	H110-11-010	Hinged presser foot asm.	1	
11	H110-11-011	Bobbin winder frame pin	1	11	H110-11-011	Feed dial	1	
12	H110-11-012	Bobbin winder frame spring	1	12	H110-11-012	Feed dog	1	
13	H110-11-013	Rubber brake	1	13	H110-11-013	Bobbin	1	
14	H110-11-014	Presser plate	1	14	H110-11-014	Throat plate	1	
15	H110-11-015	Screw 11/64-40 L=3	1	15	H110-11-015	Hand lifter cam asm.	1	
16	H110-11-016	Bobbin winder spring	1	16	H110-11-016	Presser spring	1	
17	H110-11-017	Hinge screw	1	17	H110-11-017	Needle (DA X 1 #9)	1	
18	H110-11-018	Thread tension bracket asm.	1	18	H110-11-018	Thread tension asm.	1	
19	H110-11-019	Screw	1	19	H110-11-019	Take-up Spring	(1)	
20	H110-11-020	Bobbin winder tension disc collar	1	20	H110-11-020	Tension post socket	(1)	
21	H110-11-021	Tension disc	2	21	H110-11-021	Thread tension spring	(1)	
22	H110-11-022	Tension spring	1					
23	H110-11-023	Thread tension stud nut	1					
24	H110-11-024	Screw 11/64-40 L=7.8	1					
25	H110-11-025	Wood screw	2					
26	H110-11-026	Washer	2					
27	GXJ-2	Thread stand	1					

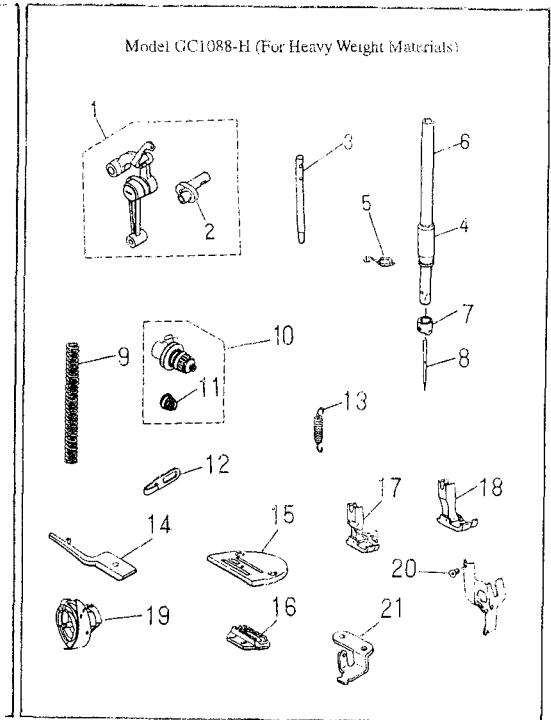

Model GC1088-H (For Heavy Weight Materials)

Ref. No.	Part No.	Description	Amt.
1	H110-12-001	Link thread take-up lever asm.	1
2	H110-12-002	Needle bar crank H	(1)
3	H110-12-003	Thread guide pin	1
4	H110-12-004	Needle bar bushing, lower	1
5	H110-12-005	Needle bar thread guide	1
6	H110-12-006	Needle bar	1
7	H110-12-007	Needle bar thread guide	1
8	H110-12-008	Needle (DB:1 #21)	1
9	H110-12-009	Presser spring	1
10	H110-12-010	Thread tension asm.	1
11	H110-12-011	Tension spring	1
12	H110-12-012	Arm thread guide (HA)	1
13	H110-12-013	Adjust link spring	1
14	H110-12-014	Positioning finger	1
15	H110-12-015	Throat plate (H)	1
16	H110-12-016	Feed dog (H)	1
17	H110-12-017	Hinged presser foot asm.	1
18	H110-12-018	Presser foot asm.	1
19	H110-12-019	Lubricating bobbin asm.	1
20	H110-12-020	Screw 1/8-44 L=2.5	1
21	H110-12-021	Feed spring hook	1