

Purchasing Dept  
Copy



**HIGHLEAD**

**GC0918-1-D/GC0918-1**

**Single needle high speed top variable feed lockstitcher**

**Instruction Manual**  
**Parts Catalog**

**SHANGHAI HUIGONG NO.3 SEWING MACHINE FACTORY**

From the library of: Superior Sewing Machine & Supply LLC



## ----- CONTENTS -----

1. PRECAUTIONS BEFORE STARTING OPERATION.....	1
1) Safety precautions .....	1
2) Precaution before Starting Operation.....	1
3) Precaution for Operating Conditions.....	1
2. SPECIFICATIONS.....	2
3. PREPARETION BEFORE STARTING OPERATION.....	2
1) Adjustment of needle bar stop position .....	2
4. PRECAUTIONS FOR STARTING OPERATION.....	3
1) Lubrication (1).....	3
2) Lubrication (2).....	3
3) Condition of lubrication .....	4
4) Lubrication adjustment for upper shaft.....	4
5) Lubrication adjustment for rotating hook .....	4
6) Lubrication adjustment for oil pump .....	4
7) Periodic cleaning (for machine).....	5
8) Precaution for position detector.....	5
9) Belt cover installation .....	5
5. HOW TO ADJUST AND USE THE MACHINE .....	5
1) Needle installation .....	5
2) Threading of upper thread.....	6
3) Stitch length adjustment and reverse sewing.....	7
4) Presser adjustment of presser foot.....	7
5) Adjusting of thread guide .....	7
6) Stitch conditions.....	8
7) Upper thread tension .....	8
8) Bobbin thread tension.....	8
9) Feed dog height.....	8
10) Adjustment of feed dog inclination.....	9
11) Winding for bobbin thread.....	9
12) Adjustment of stitch length for forward/reverse sewing.....	9
13) Adjustment of top feeding.....	10
14) Adjustment of sewing shift.....	10
15) Presser adjustment of top feed dog.....	11
16) Adjustment of feed timing .....	11
17) Side cover removal and installation.....	12
18) Position adjustment for presser bar base .....	12
19) Gauge parts replacement .....	13
20) Adjustment of upper horizontal forked arm .....	14
21) Adjustment of front and back positions for presser foot .....	15
22) Adjustment of clearance between top feed dog and presser foot.....	15
23) Adjustment of vertical motion for top feed dog .....	16



24) Adjustment of top feed arm and top feed lever.....	17
25) Adjustment of thread trimmer mechanism.....	17
26) Intermittent ruffling unit installation .....	20
<b>6. PARTS CATALOG.....</b>	<b>23</b>
A) Arm bed & Its accessories.....	23
B) Sewing mechanism .....	26
C) Feeding and feed lifting & Rotating hook shaft mechanism .....	29
D) Stitch regulator mechanism .....	32
E) Top feed rock shaft mechanism.....	34
F) Presser foot mechanism .....	37
G) Top feed mechanism.....	40
H) Knife actuating mechanism .....	43
I) Touch back mechanism & Detector mechanism .....	46
J) Oil lubrication mechanism.....	48
K) Intermittent ruffling mechanism .....	50
L) Accessories( I ).....	52
Accessories( II ).....	54
Gauges .....	56



---

# 1. PRECAUTIONS BEFORE STARTING OPERATION

## 1) Safety precautions

- (1) When turning the power on, keep your hands and fingers away from the area around/under the needle and the area around the pulley.
- (2) Power must be turned off when the machine is not used, or when the operator leaves his/her seat.
- (3) The power must be turned off before tilting the machine head, installing or removing the “V” belt, adjusting the machine, or when replacing.
- (4) Avoid placing fingers, hairs bars etc., nears the pulley, “V” belt, bobbin winder pulley, or motor when the machine is operation. Injury could result.
- (5) Do not insert fingers into the thread take-up cover, under/round the needle, or pulley when the machine is in operation.
- (6) If a belt cover, finger guard, and/or eye guard are installed, do not operate the machine without these safety devices.

## 2) Precaution before starting operation

- (1) If the machine's oil pan has an oil sump, never operate the machine before filling it.
- (2) If the machine is lubricated by a drop oiler, never operate the machine before lubricating.
- (3) When a new sewing machine is first turned on, verify the rotational direction of the pulley with the power on.  
(The pulley should rotate counterclockwise when viewed from the pulley.)
- (4) Verify the voltage and (single or three) phase with those given on the machine nameplate.

## 3) Precaution for operating conditions

- (1) Avoid using the machine at abnormally high temperature (35°C or higher) or low temperatures (5°C or lower). Otherwise, machine failure may result.
- (2) Avoid using the machine in dusty conditions.
- (3) Avoid using the machine in areas where too much electrical noise, resulted from the high-frequency welder and others, is generated.

## 2. SPECIFICATIONS

SPECIFICATION		MODEL	
		GC0918-1-D	GC0918-1
Sewing Speed	(Stitch length, 4mm or more)	3500spm	
	(Stitch length, less than 4mm)	4000spm	
Max. Feeding length	Drop feeding (mm)	5	
	Top feeding (mm)	8 (Reverse 3)	
Needle bar stroke (mm)		31.8	
Applicable Needle Type		DB × 1 (Organ needles are standard)	
Thread Take-up Lever Stroke (mm)		58	
Presser Foot Lift	Hand lifter (mm)	4	
	Knee lifter (mm)	12	
Rotating Hook		Auto lubricated hook for trimmer	Auto lubricated hook
Lubrication		Auto lubricated	
Motor		Speed adj. motor	370W Clutch motor

**CAUTION:** Some materials and/or sewing conditions may require specifications other than those listed above.

## 3. PREPARATION BEFORE STARTING OPERATION

### 1) Adjustment of needle stop position

#### (1) Adjustment of "UP" stop position

The machine will stop at the "UP" stop position, after the thread trimming has been completed by heeling the pedal. If the timing marks are off more than 3 mm from the "UP" position, adjust as follows:

- a. Disconnect the plug (including 12 pins) of the wire, extended from the machine head, at the control box.
- b. Operate the machine and, then, stop at the "UP" Stop position by heeling the pedal.
- c. While holding the pulley, insert the angle adjusting tool into two holes ① and, then, rotate the pulley.

#### (2) Adjustment of "Down" stop position

The machine will stop at the "DOWN" stop position, when the pedal is returned to the neutral position. If the timing marks are off more than 3 mm from the "DOWN" position, adjust as follows:

- a. Disconnect the plug (including 12 pins) of the wire, extended from the machine head, at the control box.
- b. Operate the machine and, then, stop at the "DOWN" Stop position by setting the pedal at neutral position.
- c. While holding the pulley, insert the angle adjusting tool into two holes ② and, then, rotate the pulley.

#### (3) Connect the plug (including 12 pins) of the wire, extended from the machine head, to the receptacle of the control box, after confirmed the stable stop position.

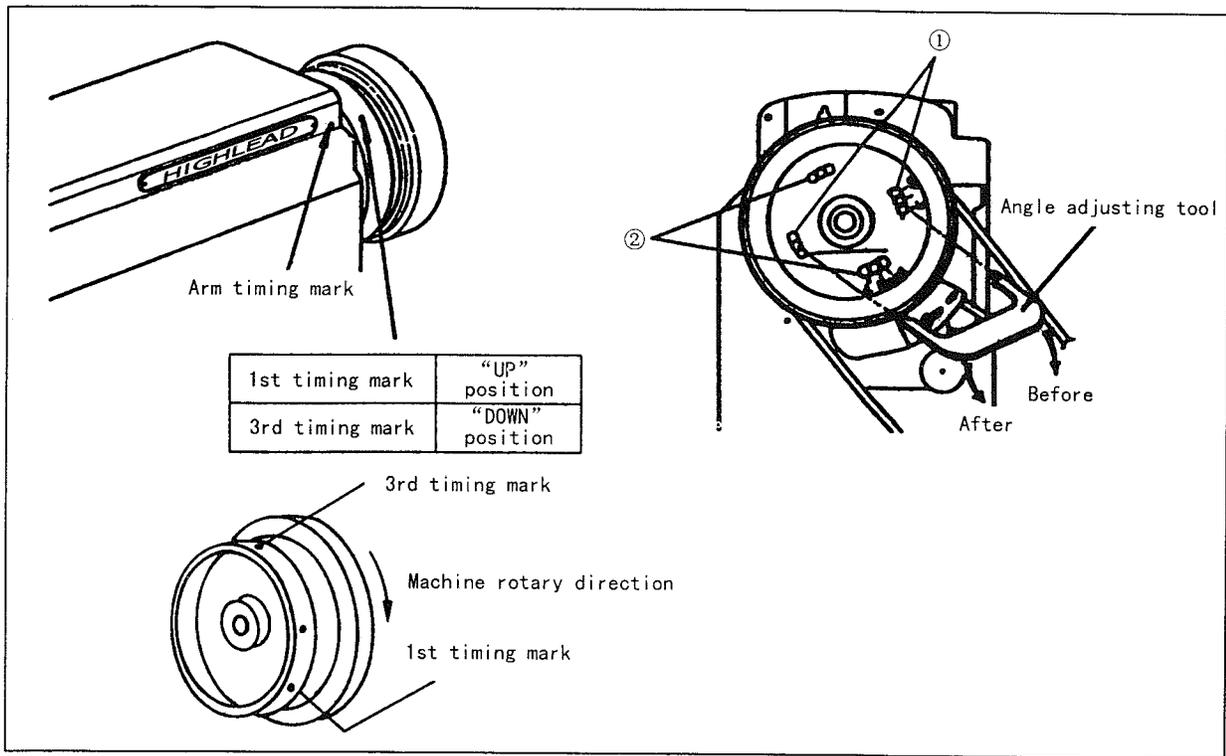

#### 4. PRECAUTIONS FOR STARTING OPERATION

##### 1) Lubrication (1)

Fill the oil tank up to **(A)** line.  
 Check the oil level periodically during operation,  
 and replenish the oil up to A line whenever the oil  
 level is below **(B)** line.

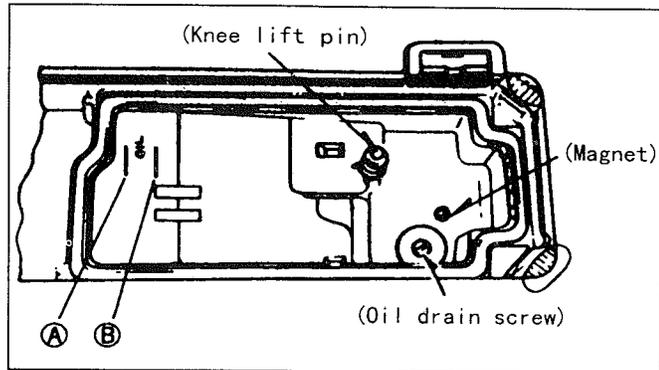

##### 2) Lubrication (2)

Remove the rubber plug indicated by the arrow  
 mark, from the machine and lubricate sufficiently,  
 when beginning to operate a new machine or a used  
 machine which has been stored a long time.

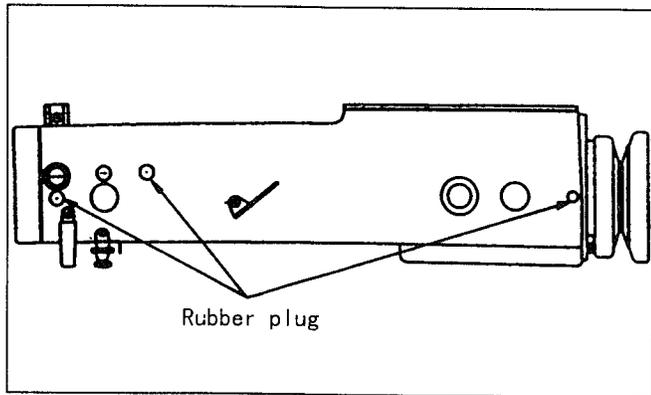

### 3) Condition of lubrication

Verify the oil splashing through the oil check window, while operating the machine.

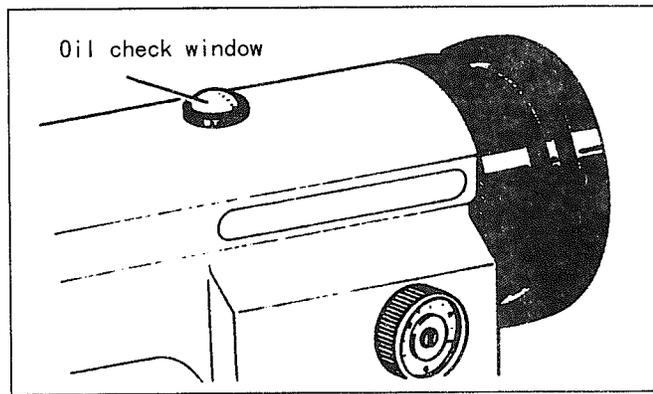

### 4) Lubrication adjustment for upper shaft

Remove the face plate, and adjust the lubricant quantity by turning the upper shaft lubricant adjusting screw (A).

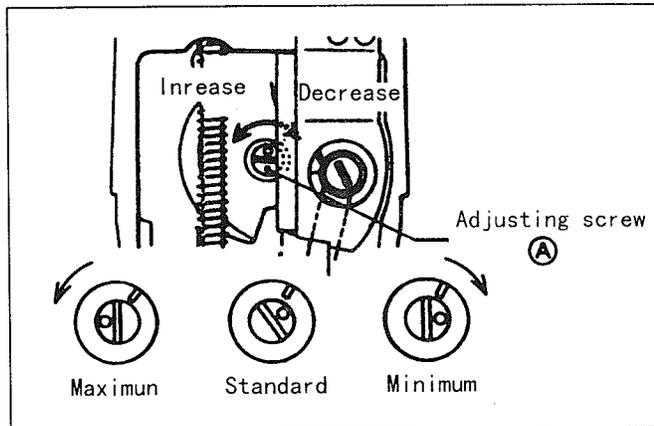

### 5) Lubrication adjustment for rotating hook

Adjustment is made by the screw (A).

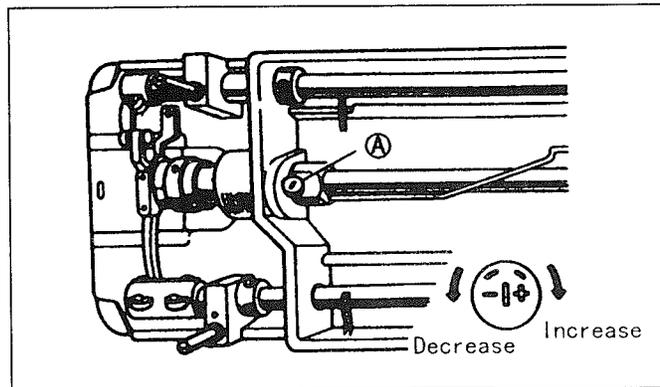

### 6) Lubrication adjustment for oil pump

The standard adjustment is as follows:  
Close the gap in the bypass hole in case of no oil splashing found through the arm oil check window under operating the machine at low speed.

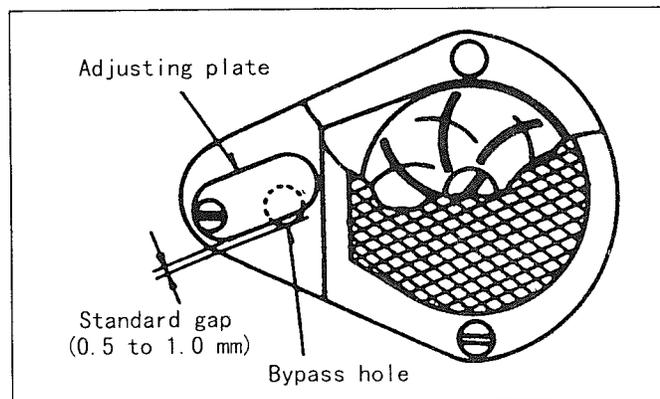

## 7) Periodic cleaning (for machine)

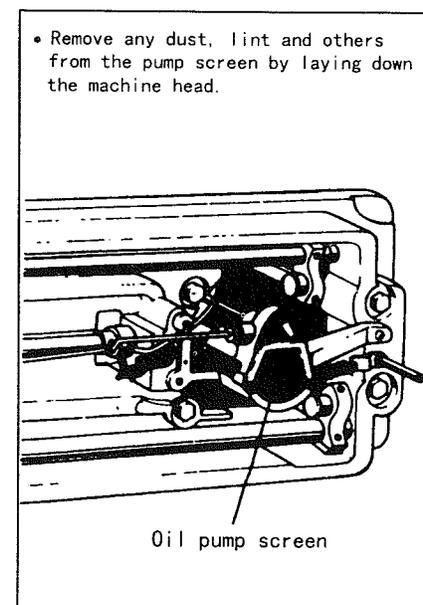
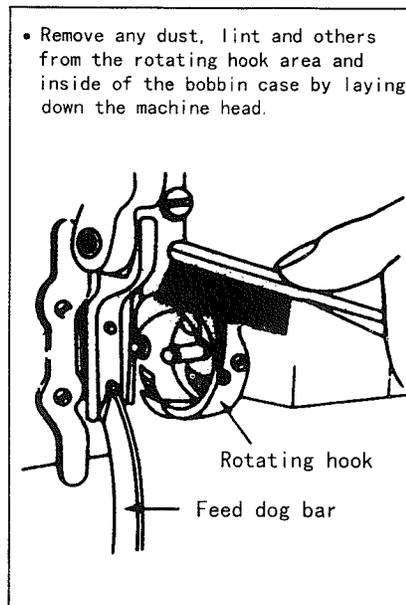
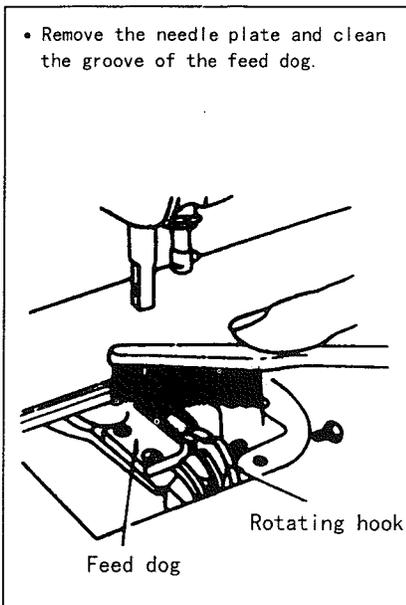

(Maintenance for motor)

Remove dust from the motor filter every one or two months. (continued operation with the filter clogged by lint or dust may cause possible overheat of the motor and the running life may be affected improperly.)

(Maintenance for control box)

Remove any dust from the connectors. (The dusty connectors may cause the machine malfunction.)

## 8) Precaution for position detector

If the connector of the needle position detector has been disconnected, the belt has been come off, or the machine has locked completely, the motor will be automatically turned off after a predetermined period of time preventing the motor from burning. (The motor may not be, however, turned off in case of incomplete locking or overloading.) The operation will be restored to normal by turning the power switch off one time and, then, turning it on again, after the failure has been remedied. The activation in case of the failure or short circuit in the detector is, also, as same as above.

## 9) Belt cover installation

(Machine side) Install the belt cover for safety. Refer to the instruction manual provided in the accessory box.

(Motor side) Install the belt cover for safety.

## 5. HOW TO ADJUST AND USE THE MACHINE

### 1) Needle installation

**Caution: Turn the power switch off before performing the needle**

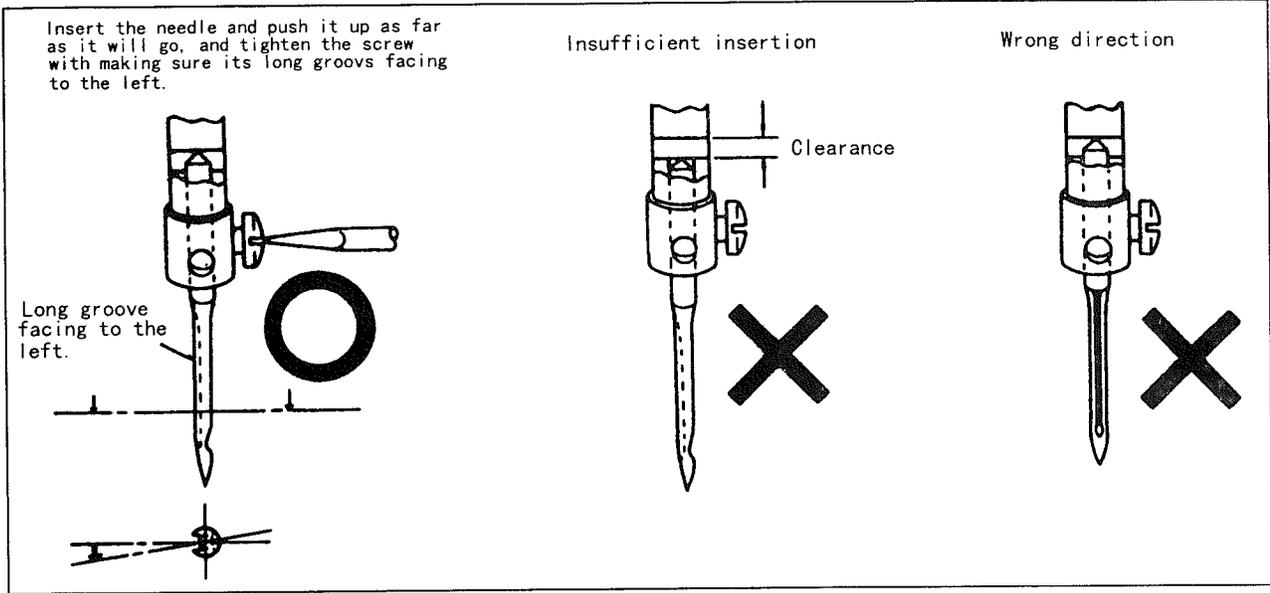

**Note: If thread breaking happens during reverse sewing with polyester threads used, this breaking may be sometime avoided by attaching the needle with the long groove shifted a little to the front side.**

The needle, DB×1 should be used. Choose the needle number in accordance with thread and materials, referring to the following table:

Needle number	Thread size	Materials
#9	#100 to #80	Very thin material such as georgette, organdy and others.
#11	#80 to #60	Thin material such as silk, calico, poplin and others.
#14	#60 to #50	Common material such as cotton, wool and others.
#16	#50 to #30	Thick material such as calico, wool and others, waterproof cloth, thin leather, and others.

## 2) Threading of upper thread

Set the thread take-up lever to its most highest position, and route the upper thread in order of No. as shown in the figure.

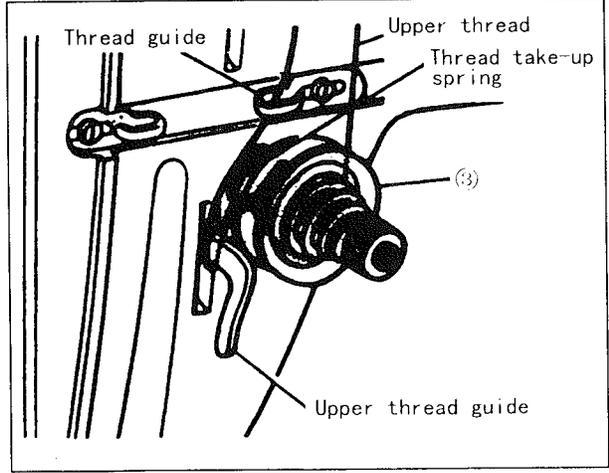
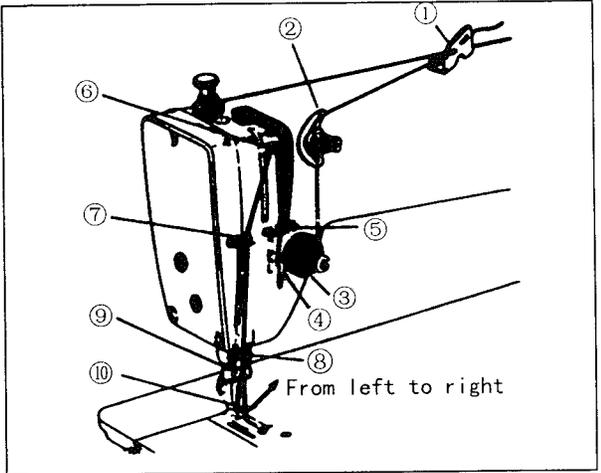

### 3) Stitch length adjustment and reverse sewing

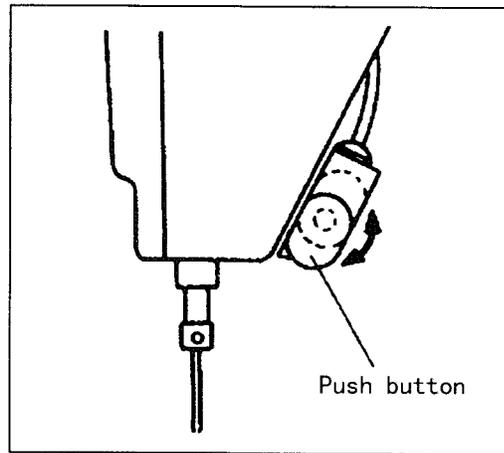
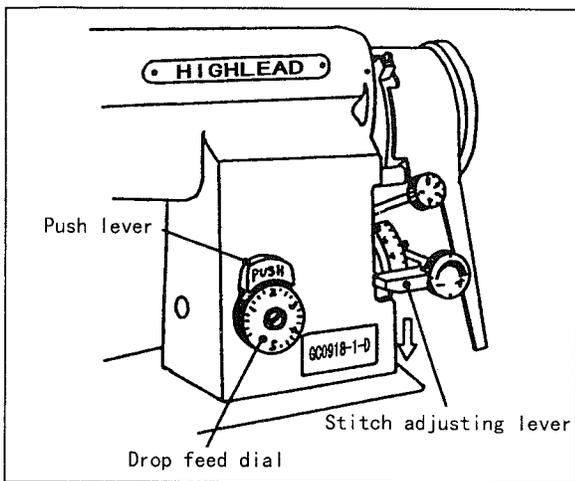

- (1) Rotate the drop feed dial while pressing the push lever, when changing the stitch length.
- (2) Rotate the drop feed dial while depressing the stitch adjusting lever and, then, pressing the push lever, when making the stitch length shorter.
- (3) The reverse sewing can be performed by depressing the stitch adjusting lever.
- (4) The reverse sewing can be performed, also, by pressing the push button of the touch switch.

### 4) Presser adjustment of presser foot

- (1) Adjust the presser to the presser foot in accordance with the sewing materials to be sewn.
- (2) The height (A) of the presser adjusting screw is approx. 40 mm as standard.
- (3) The presser to the presser foot should be adjusted to the minimum required strength.

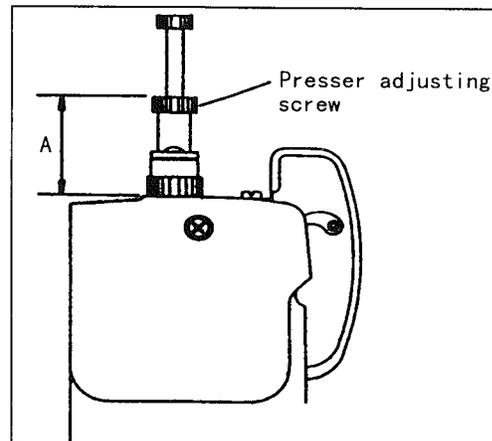

### 5) Adjustment of thread guide

Adjust the thread guide in accordance with the sewing condition for the materials to be sewn and thread.

	1	2	3
Thread guide position	Left side 	Center 	Right side 
Material to be sewn	Heavy	Medium	Light
Thread (reference)	Polyester Cotton Vinylon #30 or more	Polyester #50 or 60 Cotton Vinylon #50 or 80	Polyester #50 or 80

## 6) Stitch conditions

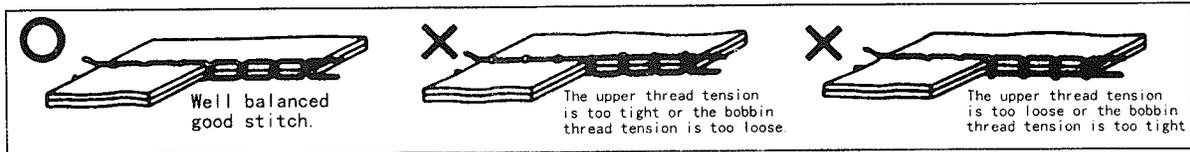

## 7) Upper thread tension

- (1) The upper thread tension can be adjusted by rotating the thread tension nut.
- (2) The upper thread tension should be adjusted, based upon the bobbin thread tension.  
In addition, the upper thread tension is adjusted in accordance with the strength and operating range of the thread take-up spring, for special fabric sewing with special material and thread.

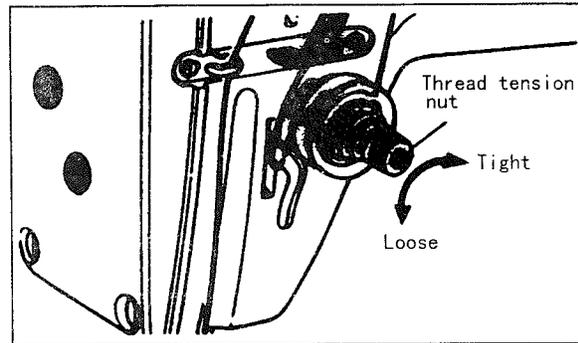

## 8) Bobbin thread tension

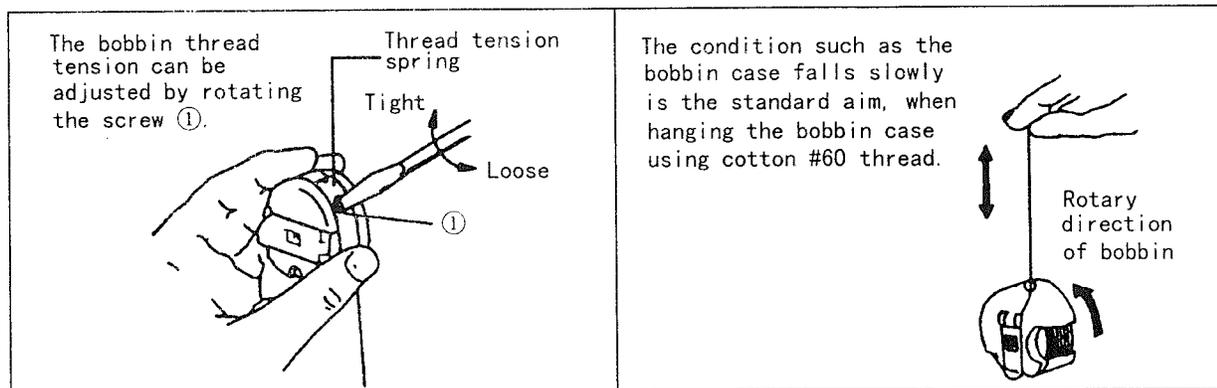

## 9) Feed dog height

- (1) The protrusion, such as the feed dog is 0.8 mm higher than the throat plate, is the standard aim.
- (2) Adjust the feed dog height as follows:
  - a. Perform the adjustment by loosening the set screw A in the feed lifting prong and, then, moving the feeding bar assy. up and down.
  - b. The setscrew A should be securely tightened after adjustment.

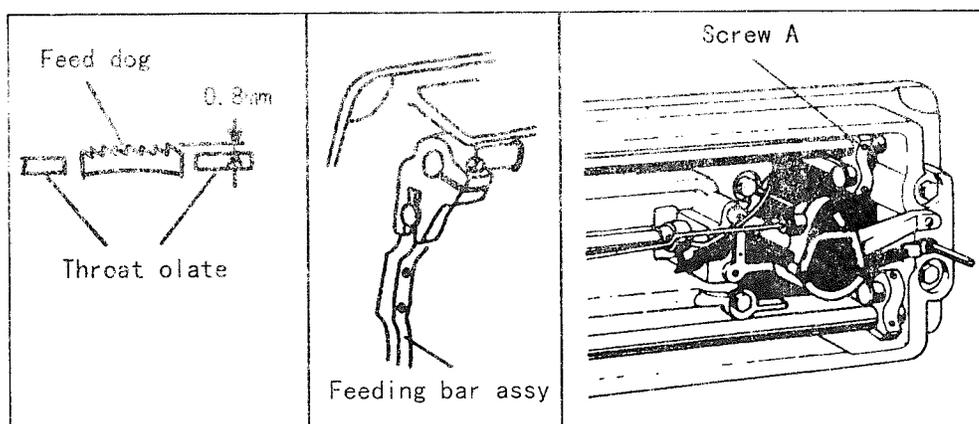

## 10) Adjustment of feed dog inclination

The feed dog has been set to the standard (horizontal level). Adjust the inclination in accordance with the sewing conditions, if necessary, as follows:

- (1) Loosen slightly the screw A located at left side top of the feeding rock shaft crank..
- (2) Rotate the eccentric shaft clockwise (to lift the front end), or counterclockwise (to lower the rear end), while pressing the groove in the eccentric shaft by using a screwdriver.
- (3) The screw A should be tightened after adjustment.

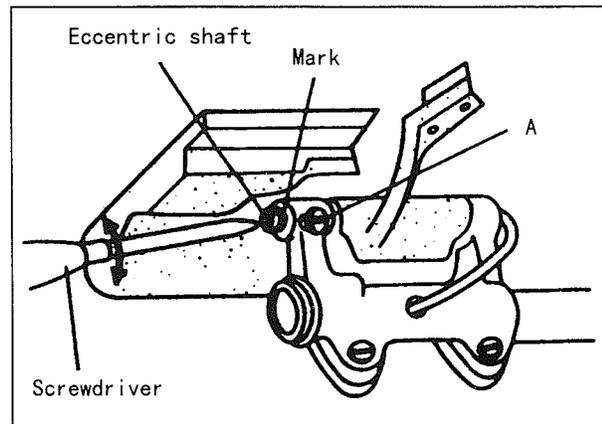

Eccentric shaft	Mark position	Feed dog	
	Horizontal		Standard (See note)
	Up		Front up
	Down		Front down (See note)

- It may be possible to have an effect on prevention of the pucker by lifting the front end of the feed dog.
- It may be possible to have an effect on prevention of the cloth shifting by lowering the front end of the feed dog.

**Note:** This table shows the conditions such as the feeding dog protrudes 0.8mm from the throat plate.

**Caution:** It is required to readjust the feed dog height in accordance with Para.9) Feed dog height, because the height will be change by adjusting the fed dog inclination.

## 11) Winding for bobbin thread

- Adjustment
- Strength of thread winding: Wind the thread loosely, particularly in case of polyester or nylon thread.
  - Uneven thread winding: Slide the thread guide toward the less wound portion of the bobbin, if the thread is wound un evenly.
  - Winding Amount: Loosen the adjusting screw when the bobbin winding amount is excessive, and tighten the adjusting screw when the winding amount is insufficient.

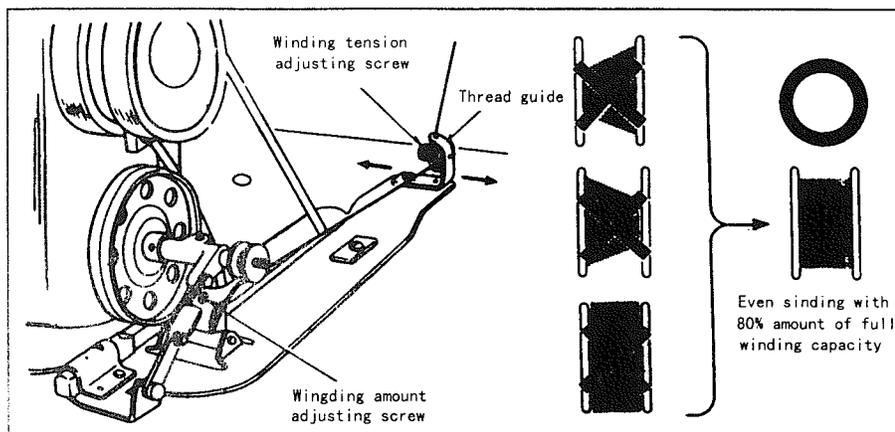

**Caution:** The presser foot should be lifted up, when running idle.

## 12) Adjustment of stitch length for forward/reverse sewing

- (1) Tilt the machine.

- (2) Depress the stitch adjusting lever and swing the Screw A to the position easy to access.
- (3) Adjust the stitch length by rotating the stitch adjusting pin.
  - The stitch length at the forward sewing will increase and the length at the reverse sewing will decrease, when turning the pin clockwise.
  - In opposition, the stitch length at the forward sewing will decrease and the length at the reverse sewing will increase, when turning the pin counterclockwise.
- (4) Tighten the screw A after adjusting.

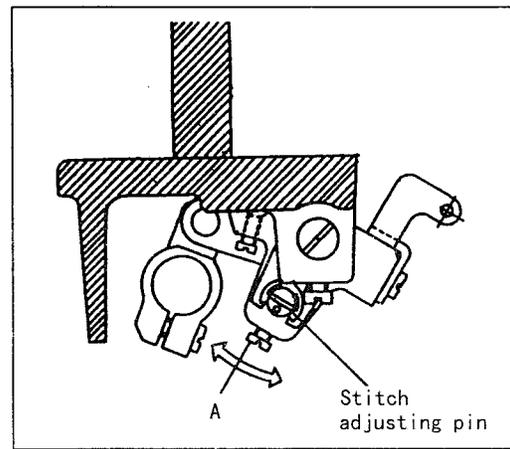

### 13) Adjustment of top feeding

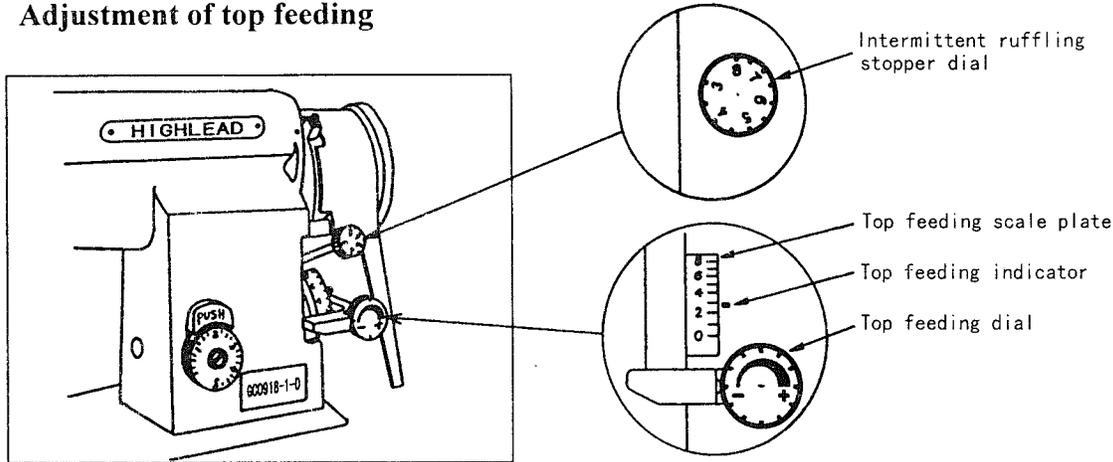

- (1) The top feeding amount will increase when turning the top feeding dial clockwise ((+) side), and decrease when turning counterclockwise ((-) side). It may be possible to make the magnitude of the top feeding amount the standard aim, in accordance with the position of the top feeding indicator on the top feeding scale plate.
- (2) The intermittent ruffling stopper dial, regulates the maximum top feeding amount, when using the intermittent ruffling sewing unit (option).
- (3) Set the intermittent ruffling stopper dial to MAX.(8 mm) in case of no intermittent ruffling sewing unit (option) used.
- (4) Set the intermittent ruffling stopper dial to MAX. as follows:
  - a. Set the top feeding dial to 3 or more.
  - b. Turn the intermittent ruffling stopper dial clockwise fully.
  - c. The position, such as the dial strikes and does not turn any more, is "MAX." position. (The scale "8" comes just above.)
  - d. Reset the top feeding dial to the desired scale.

### 14) Adjustment of sewing shift

- (1) In case of the lower cloth longer at the sewing end:  
Adjust the sewing shift by turning the top feeding dial counterclockwise ((-) side).
- (2) In case of the upper cloth longer at the sewing end:  
Adjust the sewing shift by turning the top feeding dial clockwise ((+) side).

- (3) **Ruffling sewing**  
 Turn the top feeding dial clockwise ((+) side) with using pusher type gauge and separator.  
 The ruffling sewing is possible by increasing the top feeding amount.

**Caution: Operate the machine with speed 3500 rpm or less in case of the top feeding amount 4 mm or more ,or the drop feeding amount 4 mm or more.**

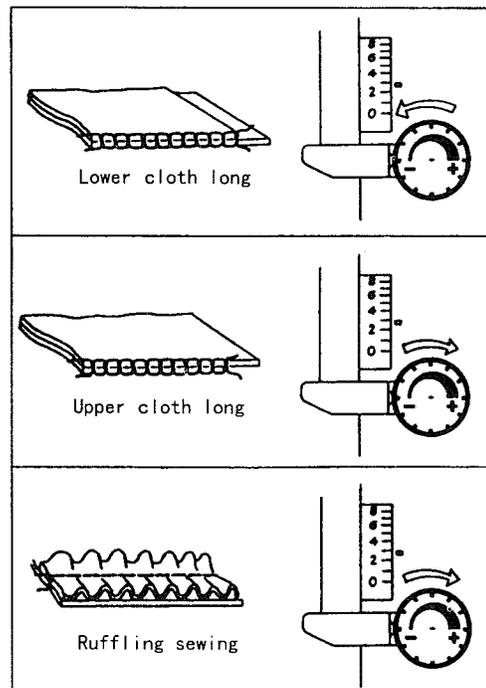

### 15) **Presser adjustment of top feed dog**

- (1) Press down the top feed adjusting knob. The presser to the top feed dog will become stronger when turning . the knob clockwise, and weaker when turning counter-clockwise. (Rotate the top feed presser adjusting knob in such condition as engaged firmly, after depressing downward.)
- (2) The height A is approx. 51 mm as standard, when the top feed adjusting knob is depressed downward, with the presser foot bottom contacted to the throat plate after dropping the presser foot down.
- (3) The stronger the top feed dog pressure becomes, the better the top feed efficiency will become. The weaker the top feed dog pressure becomes, the worse the top feed efficiency will become.
- (4) It should be avoid to make the top feed dog pressure stronger too much, because the cloth may result in slip or damage due to the presser foot lifted up by the top feed dog.

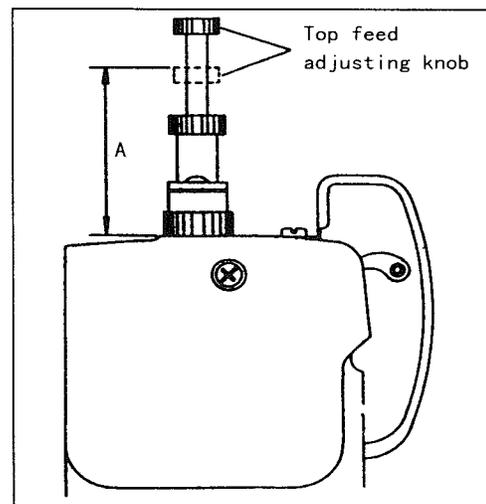

### 16) **Adjustment of feed timing**

- (1) The standard assemble condition for the eccentric cam is that the oil hole for the upper shaft should be aligned with the third flush type screw as shown in the figure.
- (2) The adjustment is to be performed by opening the side cover and by changing the set position of the eccentric feed cam.

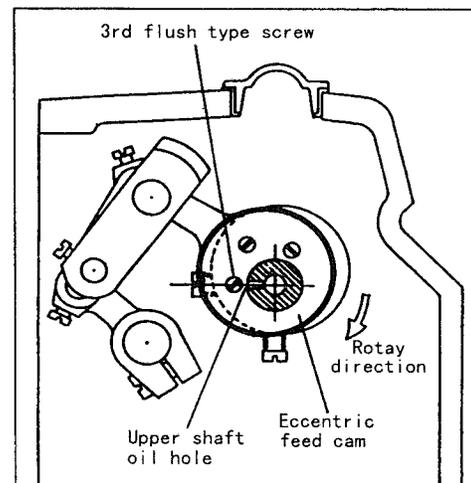

## 17) Side cover removal and installation

A solenoid for automatic reverse sewing is mounted on the side cover. When the reverse sewing solenoid is energized by the signals from the touch switch and others, the reverse plate will sway. This will cause the reverse plate to pull up the reverse pull bar, and to rotate the feed adjusting cam to the position which will initiate the reverse sewing, and the reverse sewing will be conducted.

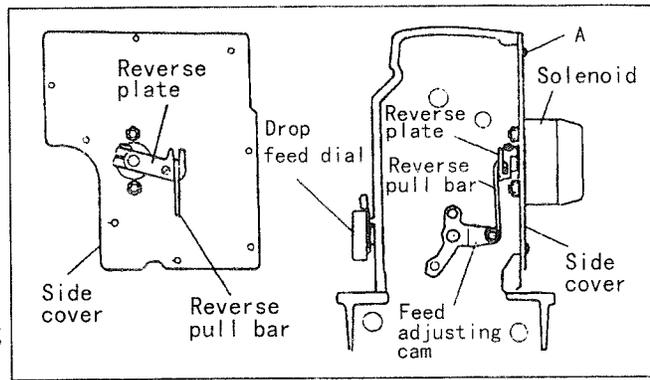

### (1) Side cover removal

- a. Set the stitch adjusting dial to "zero".
- b. Remove the mounting screws A (8 pieces).
- c. Rotate the side cover so that the groove B of the reverse plate is in horizon, as shown in the figure on the left side.
- d. Remove the reverse pull bar from the groove B of the reverse plate.

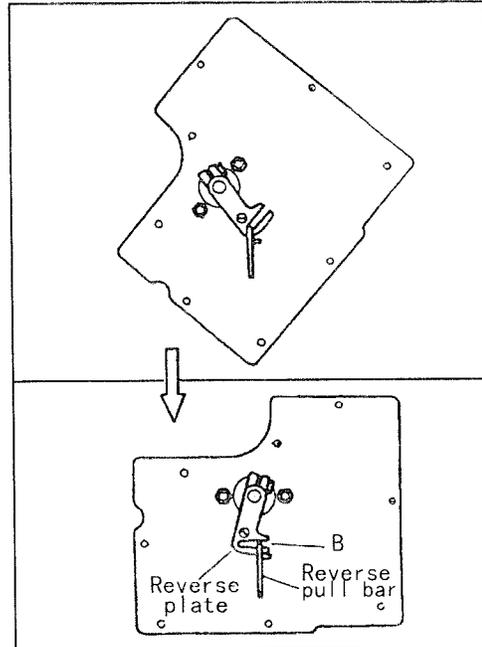

### (2) Install the side cover in reverse order as described above.

Adjust the set position of the reverse plate, related to the automatic reverse sewing, so that the distance C will be 76.5 mm, by using the bolt D.

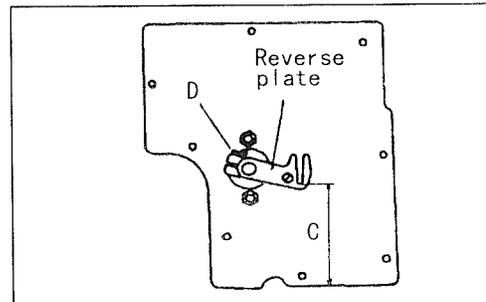

## 18) Position adjustment for presser bar base

- (1) Set the feed dog position lower than the needle plate surface.
- (2) Raise the presser foot lifter.
- (3) Insert the 4 mm block chip between the presser foot and the needle plate.
- (4) Fasten the screw A of the presser bar base so that the bottom of the presser foot touch the 4 mm block chip.
- (5) When fasten the screw A of the presser bar base, adjust the clearance B between the feed rocker bar bushing and the presser bar base evenly and set the presser foot in proper condition that the needle position is on the center line of the slot of the presser foot.

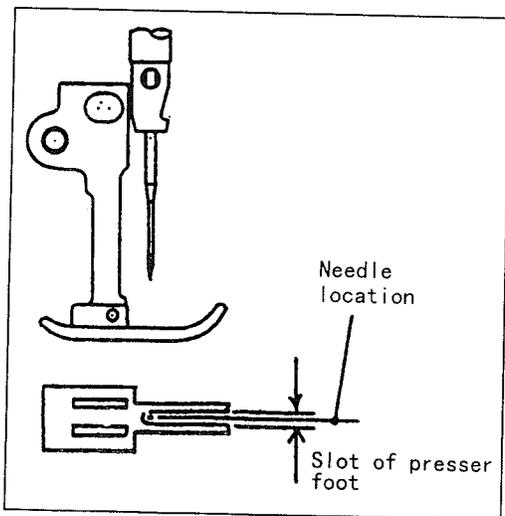
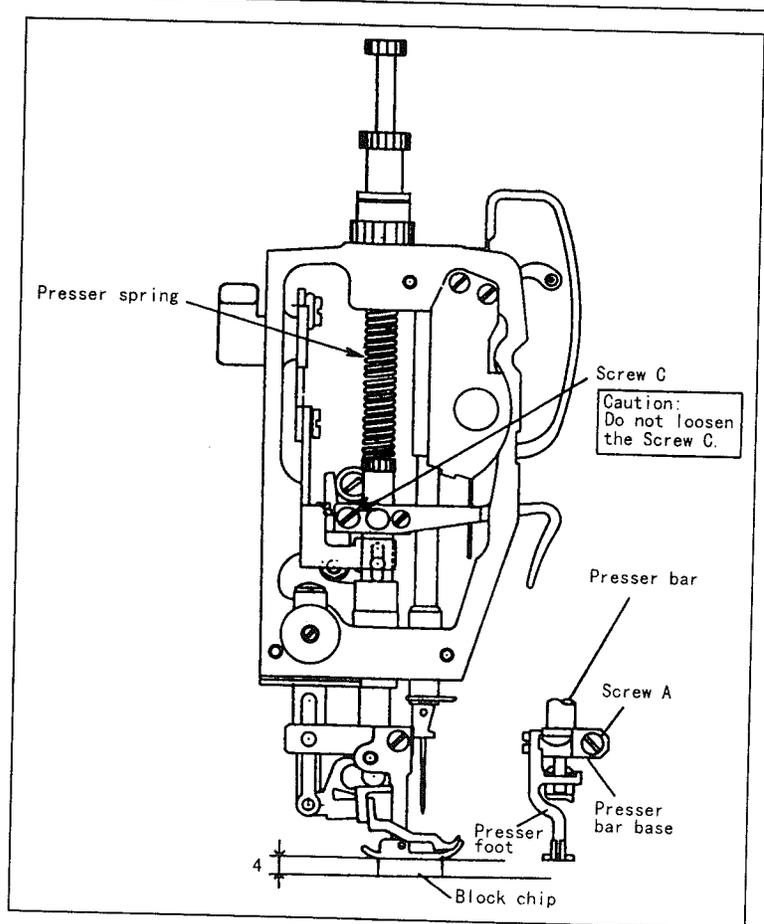
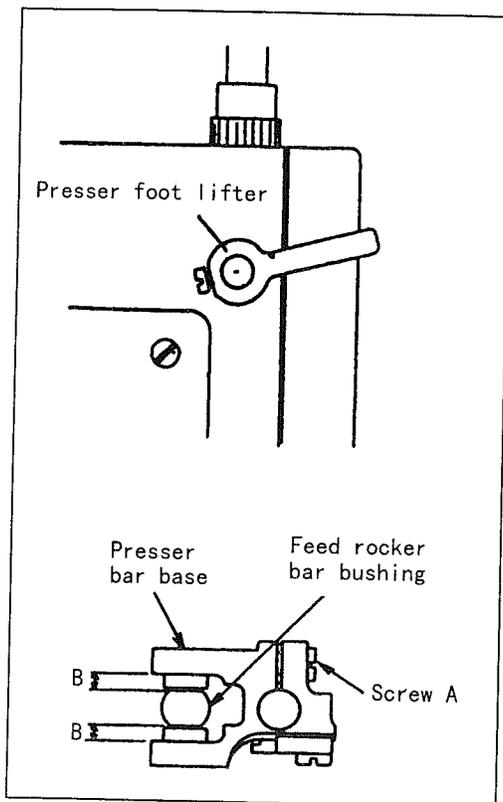

- (6) Make sure the presser bar base can be moved up and down smoothly by removing the presser spring.  
If it can not move smoothly, adjust again with same procedures mentioned above.
- (7) Set back the presser spring.

## 19) Gauge parts replacement

- (1) Gauge removal
  - a. Remove the needle by loosening the needle set screw A.
  - b. Remove the presser foot by loosening the presser foot set screw B. (It is very easy to remove the presser foot by raising the Top feed dog up.)
  - c. Remove the Top feed dog by removing the Top feed dog set screw C.
  - d. Remove the throat plate by removing the throat plate set screw D. (It is very easy to loosen or tighten the throat plate set screw D by using the driver plate included in the accessories.)
  - e. Remove the Drop feed dog by removing the Drop feed dog retaining screw E.
- (2) Gauge installation
  - a. The installation should be conducted in the reverse order of the gauge removal.

- b. Confirm the height of the Drop feed dog after installation.
- (3) Commercial gauge installation
- a. Install the commercial gauge by inserting each spacer (included in the accessories) underneath the feed dog and the throat plate.

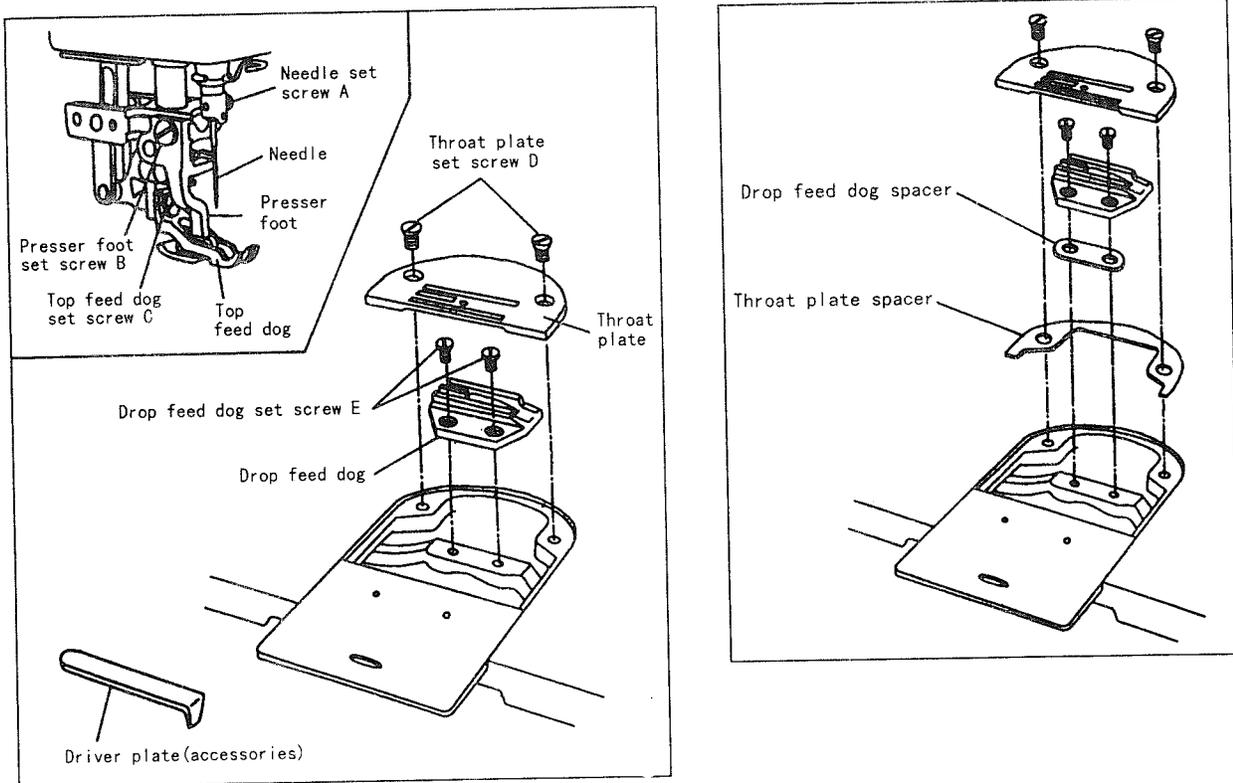

## 20) Adjustment of upper horizontal forked arm

- (1) Set the drop feed dial to "3", and the intermittent ruffling stopper dial and the Top feeding dial to MAX. (8), respectively.
- (2) The clearance A between the upper horizontal forked arm and the arm (the side cover attaching surface) is to be adjusted to approx. 5.5 mm, when the lower end of the upper horizontal forked arm comes nearest to the left side.
- (3) The adjustment should be conducted at the setscrew C by loosening the screw B.
- (4) Tighten the screw B and screw C securely after adjusting.

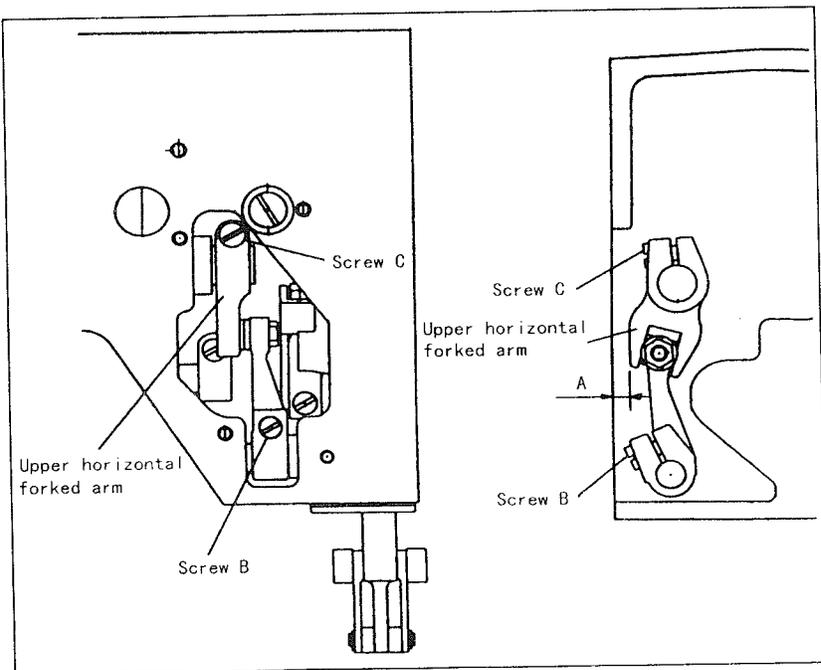

## 21) Adjustment of front back positions for presser foot

- (1) the attaching hole A is a elongated hole.
- (2) The distance B between the presser foot long groove and the needle drop center is to be adjusted to approx. 1 mm , when installing the presser foot by using the screw C.

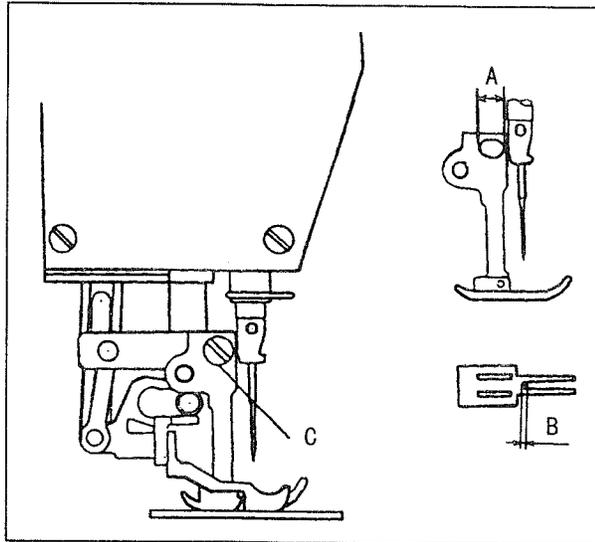

## 22) Adjustment of clearance between top feed dog and presser foot

- (1) Set the top feeding amount to MAX.(8 mm) position.
- (2) Rotate the pulley, until the clearance A (the clearance between the top feed dog and the presser foot, when the top feed dog comes nearest to the left side, in case of the pusher type gauge) or the clearance B (the clearance between the top feed dog and the presser foot, when the top feed dog comes nearest to the right side, in case of the puller type gauge) will become the minimum.
- (3) Remove the side cover from the back side of the arm.
- (4) Loosen the setscrew C on the upper horizontal arm.
- (5) Move the top feed dog, so that the dimension A (in case of the pusher type gauge) or the dimension B (in case of the puller type gauge) becomes 1.0 mm.
- (6) Tighten the setscrew C on the upper horizontal arm.

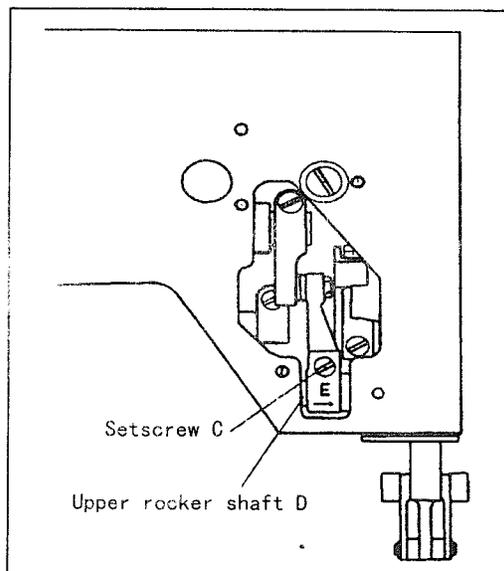
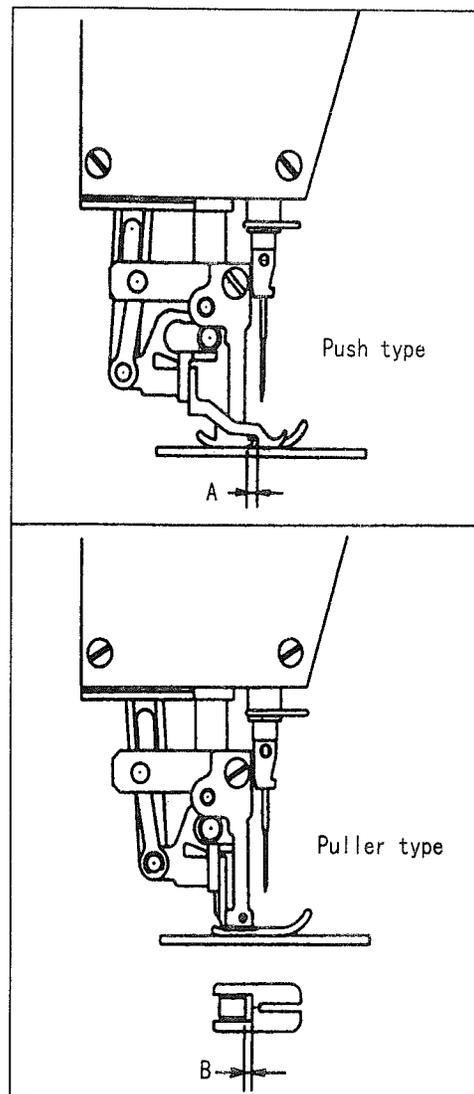

**Caution:** It is recommended to tighten the setscrew C, while pushing the upper horizontal arm lightly to the direction of the arrow mark E so that no play occurs on the upper rocker shaft D to in the direction of the thrust.

### 23) Adjustment of vertical motion for top feed dog

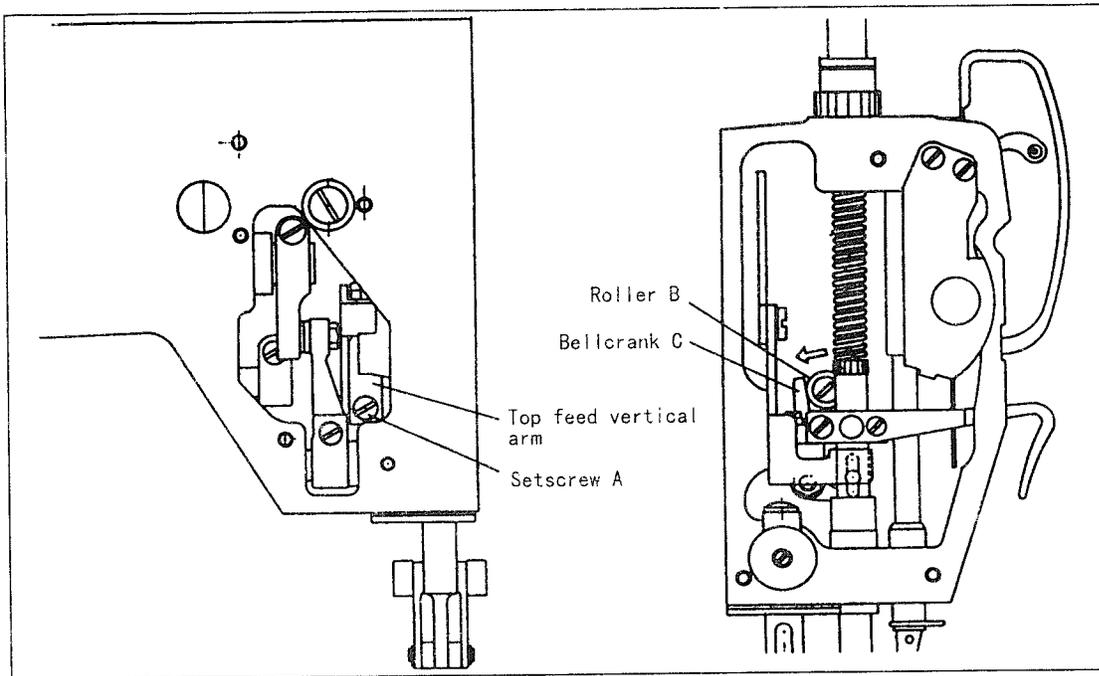

- (1) Remove the side cover from the back side of the arm.
- (2) Set the horizontal feeding amount of the top feed dog to approx. 3 mm.
- (3) Set the top feed dog at the most highest position by turning the pulley.
- (4) Loosen the setscrew A on the top feed vertical arm.
- (5) Adjust the rising dimension D with the roller B on the top feed vertical arm pushing the bell crank C, so that it becomes the dimensions as follows:

In case of the pusher type top feed dog	3.0 mm
In case of the puller type top feed dog	1.6 mm

- (6) Tighten the setscrew A securely after adjusting.

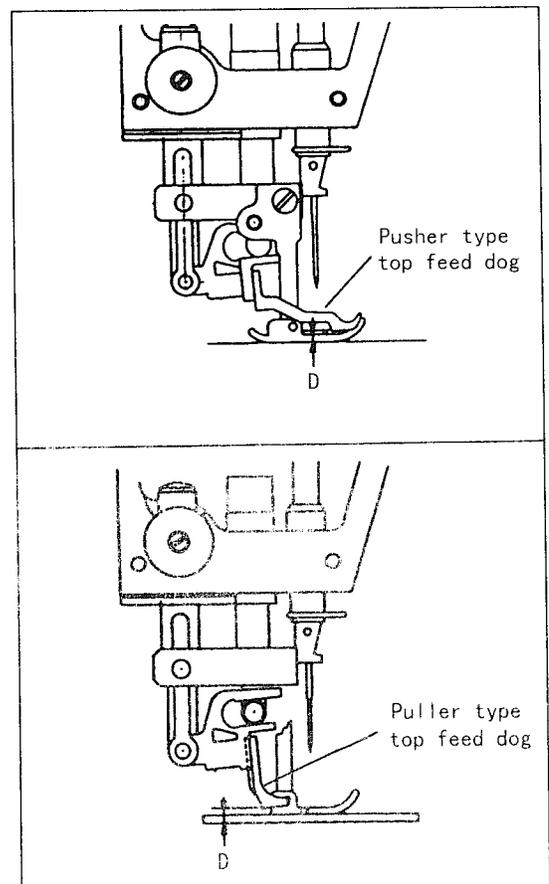

## 24) Adjustment of top feed arm and top feed lever

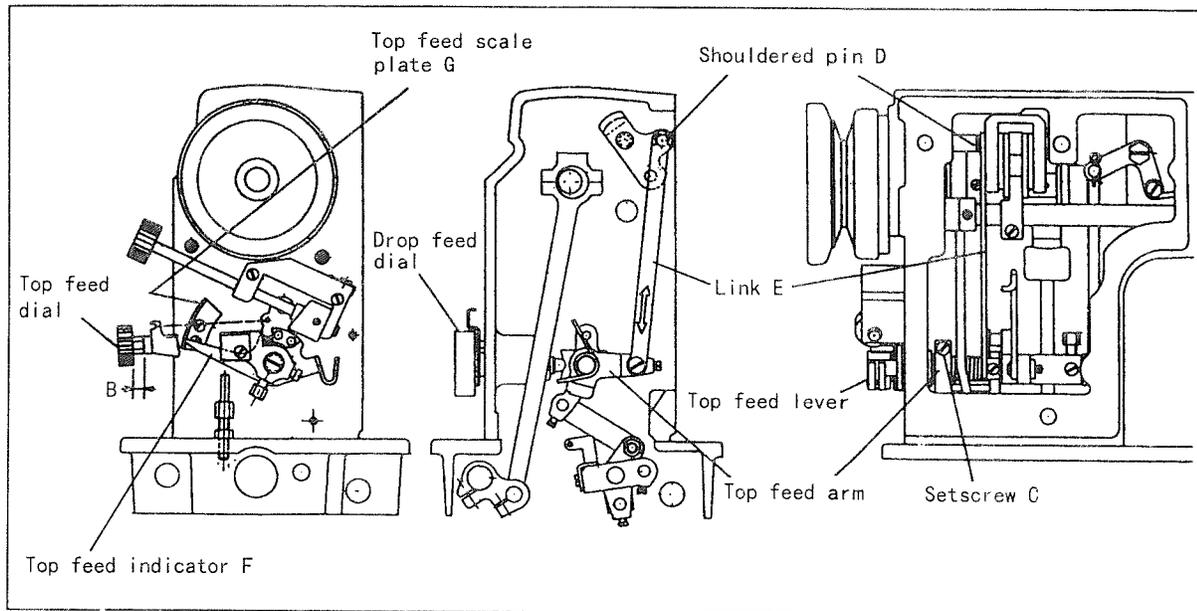

- (1) Set the drop feed dial A to "0".
- (2) Adjust the dimension B to 6.5 mm or more by turning the top feed dial.
- (3) Loosen the setscrew C on the top feed arm.
- (4) Adjust the link E up and down so that the shouldered pin D will be arranged sideways.
- (5) Align the top feed indicator F on the top feed lever with the zero point on the top feed scale plate.
- (6) Tighten the setscrew C on the top feed arm securely.

## 25) Adjustment of thread trimmer mechanism

- (1) Construction of thread trimmer mechanism

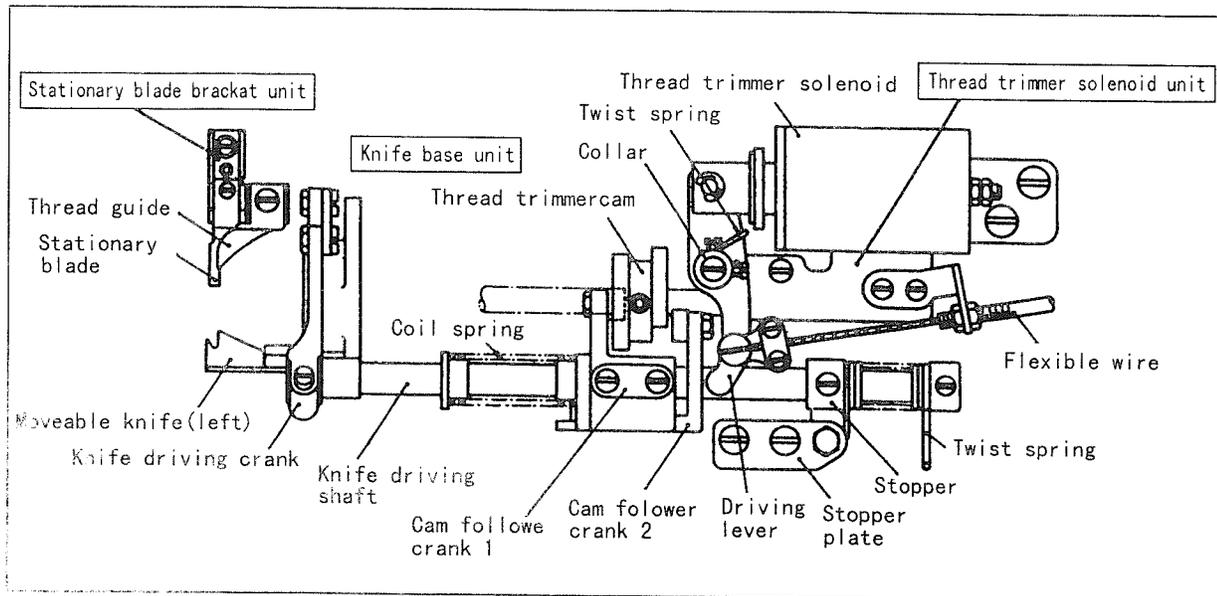

- (2) Precautions during adjustment

A hook shaft cam method is utilized for the thread trimmer drive. Accordingly, the moveable knife (left) will hit the needle resulting in damage, when rotating the machine by one revolution with the thread trimmer solenoid activated (i.e. with the roller on the cam follower crank 2 engaged with the thread trimmer cam), during the machine adjustment.

(from lower position to upper position) is operating.

- (3) Relation between stationary blade and movable knife(left) edge
- The standard relative position is shown in the figure.
  - If the dimension (0.3 mm) as shown in the figure is too wide, a "triple" thread cutting off may occur causing the upper thread coming out of the needle after the trimming. If the dimension is too narrow, this situation may cause, also, the thread trimming failure. It is, therefore, desired to pay attention to this dimension.
  - The adjustment described in Step (2) is to be conducted when installing the stationary blade bracket unit or the stationary blade.
  - The stationary blade bracket unit is installed with the screw A under the bobbin case holder removed as shown in the figure.

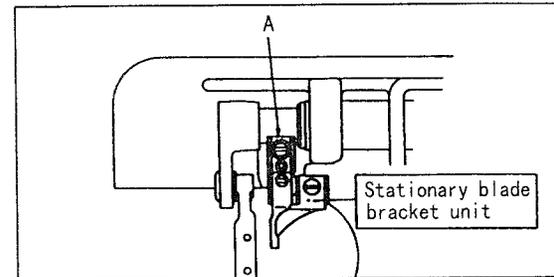
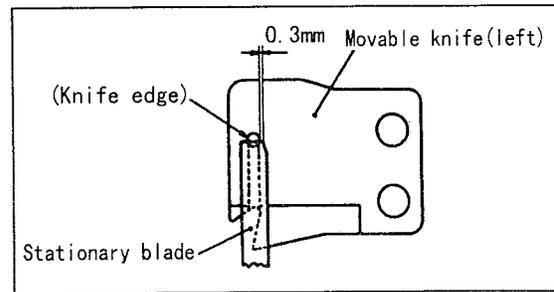

- (4) Knife driving shaft
- The standard set position is shown in the figure.
  - The knife driving shaft should be put through the knife driving crank first when assembling.
  - The cam follower crank 1 should be secured on the recess on the knife driving shaft as shown in the figure.
  - The stopper should be secured on the recess in such a way that the knife driving shaft rotates smoothly with no play on the shaft direction.

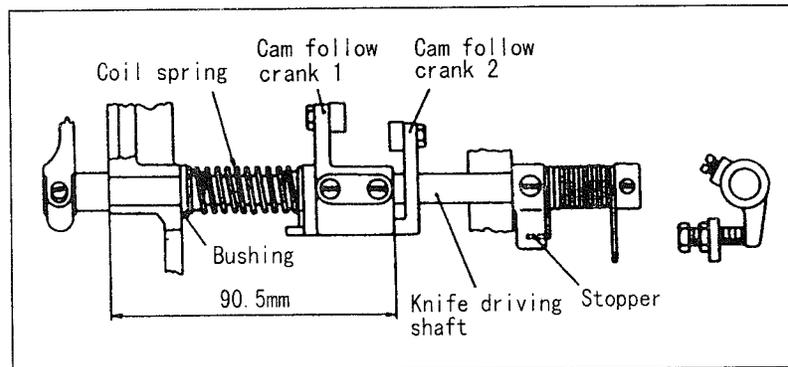

- (5) Thread trimmer solenoid unit installation
- Stroke of thread trimmer solenoid:
    - Standard stroke is 6.0 mm.
    - The adjustment of the stroke is to be conducted by using the nut A.
  - Unit installation:
    - The unit is to be installed by using the screws B and C as shown in the figure.
    - The unit should be installed so that the clearance, between the driving lever and the cam follower crank 2, will be approx. 2.0 mm with the stopper nut A made contact with the solenoid.
    - A possible clearance of 0.5 mm will be created between the cam follower cranks 1 and 2, if the

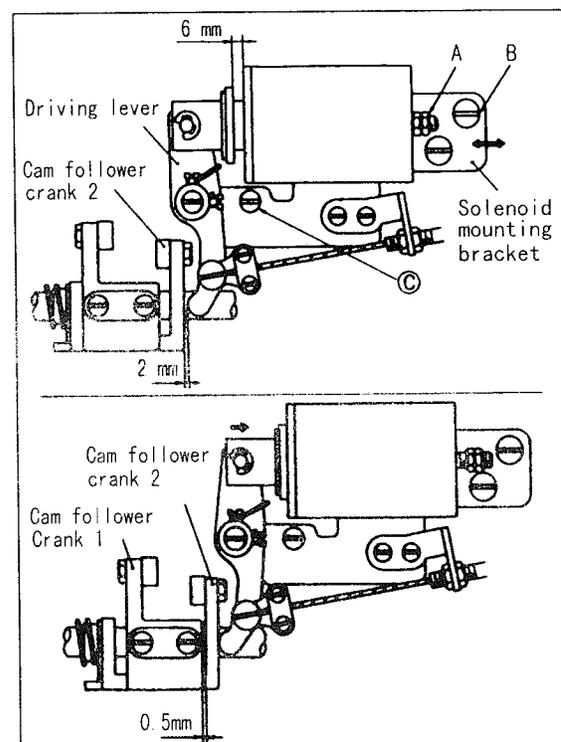

solenoid is energized in such condition, as shown in the figure. This situation is standard. The adjustment is to be performed by moving the solenoid mounting bracket in the direction of the arrow as shown in the figure.

(6) Thread trimming cam installation

- a. Mate the 2nd timing mark A on the pulley with the matching mark on the arm.
- b. Secure the thread trimmer cam at the point where the cam comes into contact with the roller, by rotating the cam in the direction of normal running with the thread trimmer solenoid energized.
- c. The clearance of 0.5 to 1.0 mm between the cam and the cam follower end is standard with the thread trimmer solenoid released and the cam follower crank 2 restored.

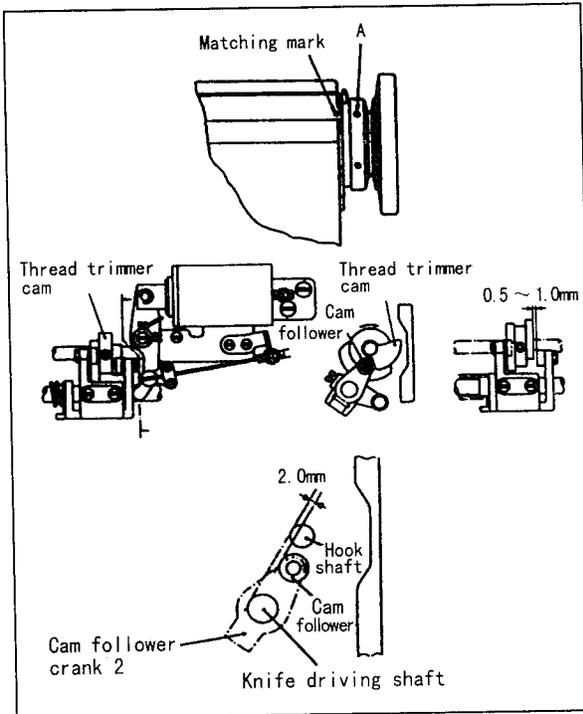

**Caution: The standard position of the cam follower crank 2 prior to the activation is shown in the figure. Perform the adjustment described in Steps (1) through (3) above, after adjustment by using the adjusting bolt on the stopper plate first, when this position is changed in such case of stopper plate removal.**

(7) Adjustment of knife engagement

- a. Position of movable knife (left) and stationary blade:
  - ① The distances of 7.0 mm and 2.5 mm from the needle center are standard as shown in the figure.
- b. Adjustment of knife engagement:
  - ① The movable knife (left) will be rotated by the thread trimmer cam, when turning the machine pulley with the solenoid energized. The engagement amount of 1.5 to 2.0 mm is standard, when the movable knife (left) has moved farthest.
  - ② The adjustment is to be conducted with the knife driving shaft installation.
- c. Adjustment of knife engagement pressure:
  - ① The condition, which the movable knife (left) commences to come into contact with the stationary blade, is standard as shown in the figure.
  - ② It is very effective for cutting to increase the engagement pressure slightly, especially in case of dull cutting with thick thread.
  - ③ The adjustment of the knife engagement pressure is to be conducted by loosening the locknut B and using the adjusting screw A as shown in the figure.

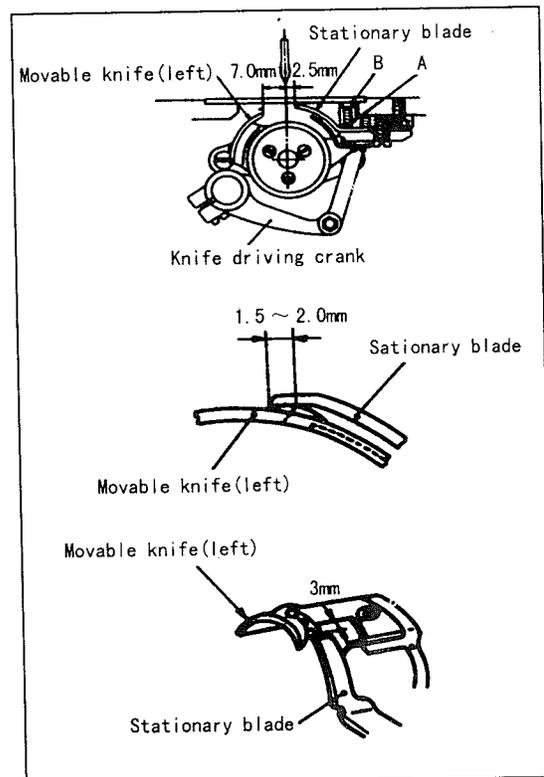

- (8) Adjustment of upper thread tension release
  - a. The upper thread tension release should be adjusted so that the tension discs of the thread tension regulator will open by approx. 1.0 mm with the thread trimmer solenoid energized.
  - b. The adjustment is to be conducted by loosening the nut A and moving the flexible wire as shown in the figure.

**Caution:** If opening of the tension discs are too narrow, the upper thread may be cut shortly causing the upper thread coming out the needle. If the opening are too wide, the space between the discs will be kept always excessive open and may result to the loosing stitch.

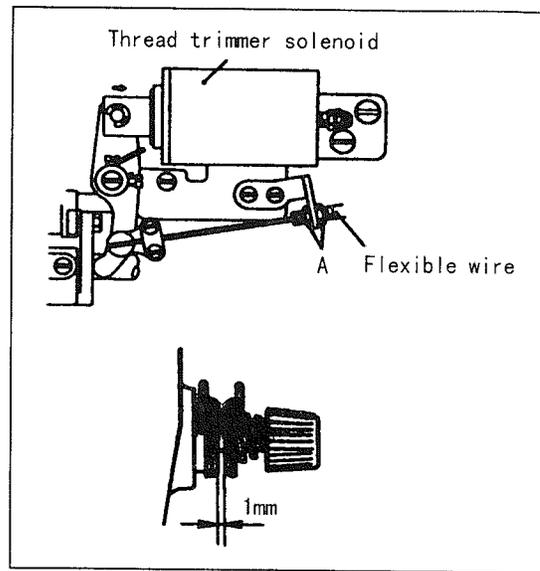

- (9) Adjustment of upper thread tail
  - a. The adjustment of the upper thread tail is to be conducted by using the pretension regulating nut A as follows:  
 Turning clockwise ..... Short tail  
 Turning counterclockwise ..... Long tail

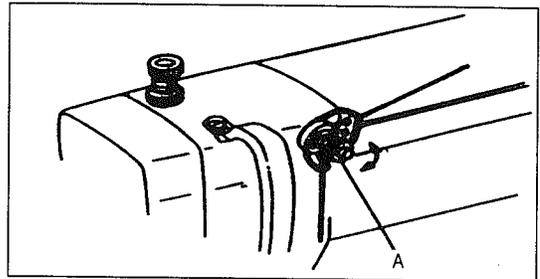

**26) Intermittent ruffling unit installation**

- (1) Installation on the machine head and the table, and the adjustment
  - a. Pass the ruffling wire 2 through the wire tube guide 3 and the oil pan 4 and bring it out of the surface of table.
  - b. Set the arm 1 .
  - c. Fix the wire support plate 2c on the right flank of the arm 1 using a screw 5 .
  - d. Attach the wire terminal 2b to the hook section 6a of top feed lever 6.
  - e. Fix the wire support plate 2e on the rear face of table 9 using a wood screw 8.
  - f. Fix the wire terminal plate 2d on the lever 14 with a screw 7.
  - g. Attach the spring 16 to the pin 15 behind the lever 14 and the spring hook 10 on the wire support plate.
  - h. If the nut 13 is loosened and the stopper 12 is turned to right, the gap between the wire terminal 2b and the wire terminal 2a ( $\ell$ ) is reduced while it is increased with left turns.
  - i. Set the gap  $\ell$  at 3 mm for both the upper and the lower feed so that the gap is

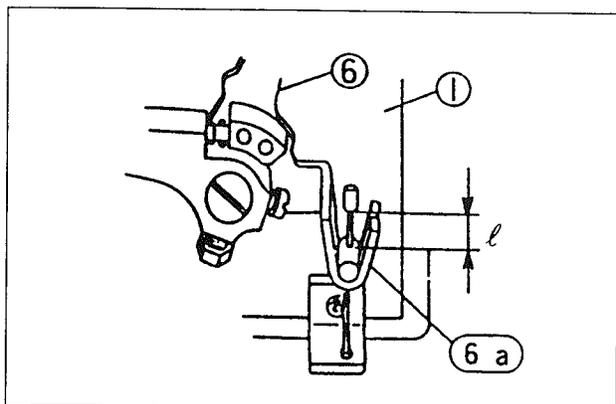
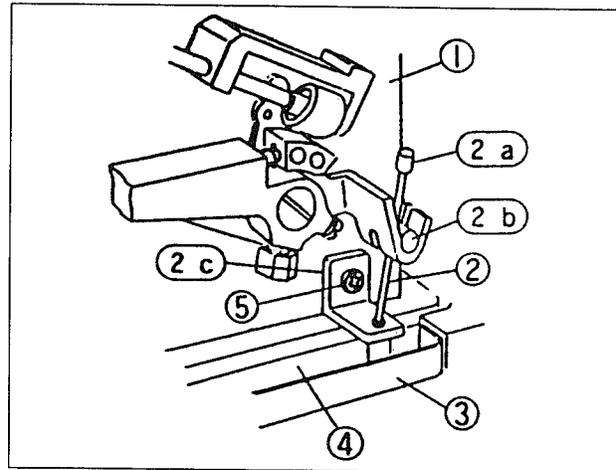

adjusted at 0 when the feed lever is put to the state of reverse sewing.

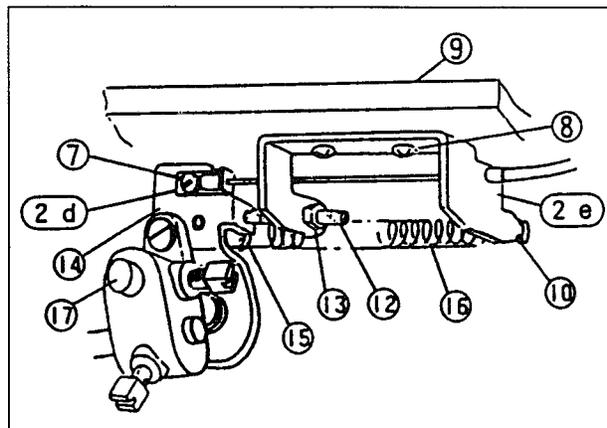
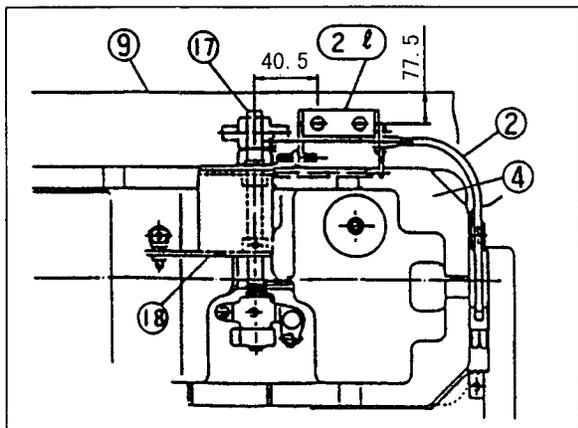

(2) Operating method

- a. When it comes to the position to make the ruffle sewing, the ruffling sewing can be done by operating the pedal.
- b. As the pedal is reverted, it returns to the ordinary sewing.

(3) Adjustment of ruffling amount

- a. Operate the pedal and confirm the top feeding indicator 41 moves.
- b. The value indicated with the indicator 41 when the pedal is not operated, means the upper feed pitch under the ordinary sewing state.
- c. The value indicated with the indicator 41 when the pedal is fully toed down, means the max. upper feed pitch at the intermittent ruffling sewing.
- d. Max. upper feed pitch at the intermittent ruffling sewing is adjusted by turning the intermittent ruffling stopper dial 38. The pitch is extended with a right turn while it is reduced with a left turn.
- e. To confirm the max. upper feed pitch at the intermittent ruffling sewing, toe down fully the pedal and turn the intermittent ruffling stopper dial 38 watching the value pointed on the scale plate 40.

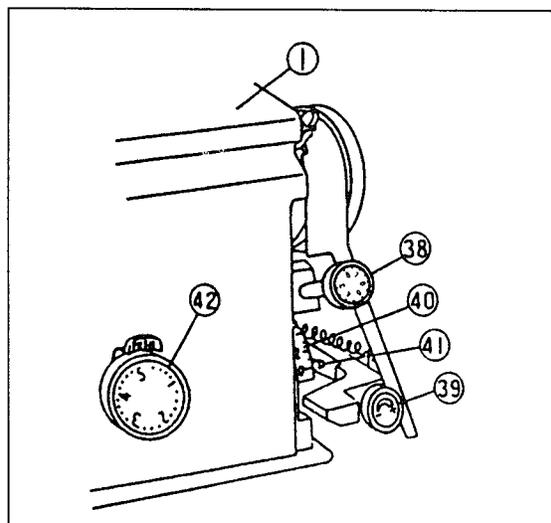

- (4) Installation of intermittent ruffling pedal  
Install the pedal as shown by the figure.

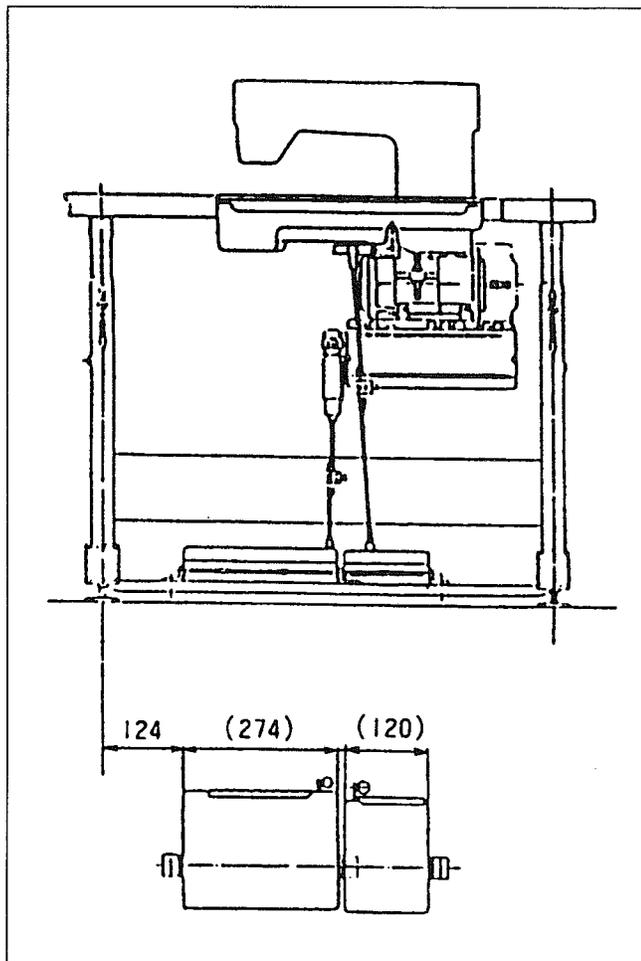

# A.ARM BED AND ITS ACCESSORIES

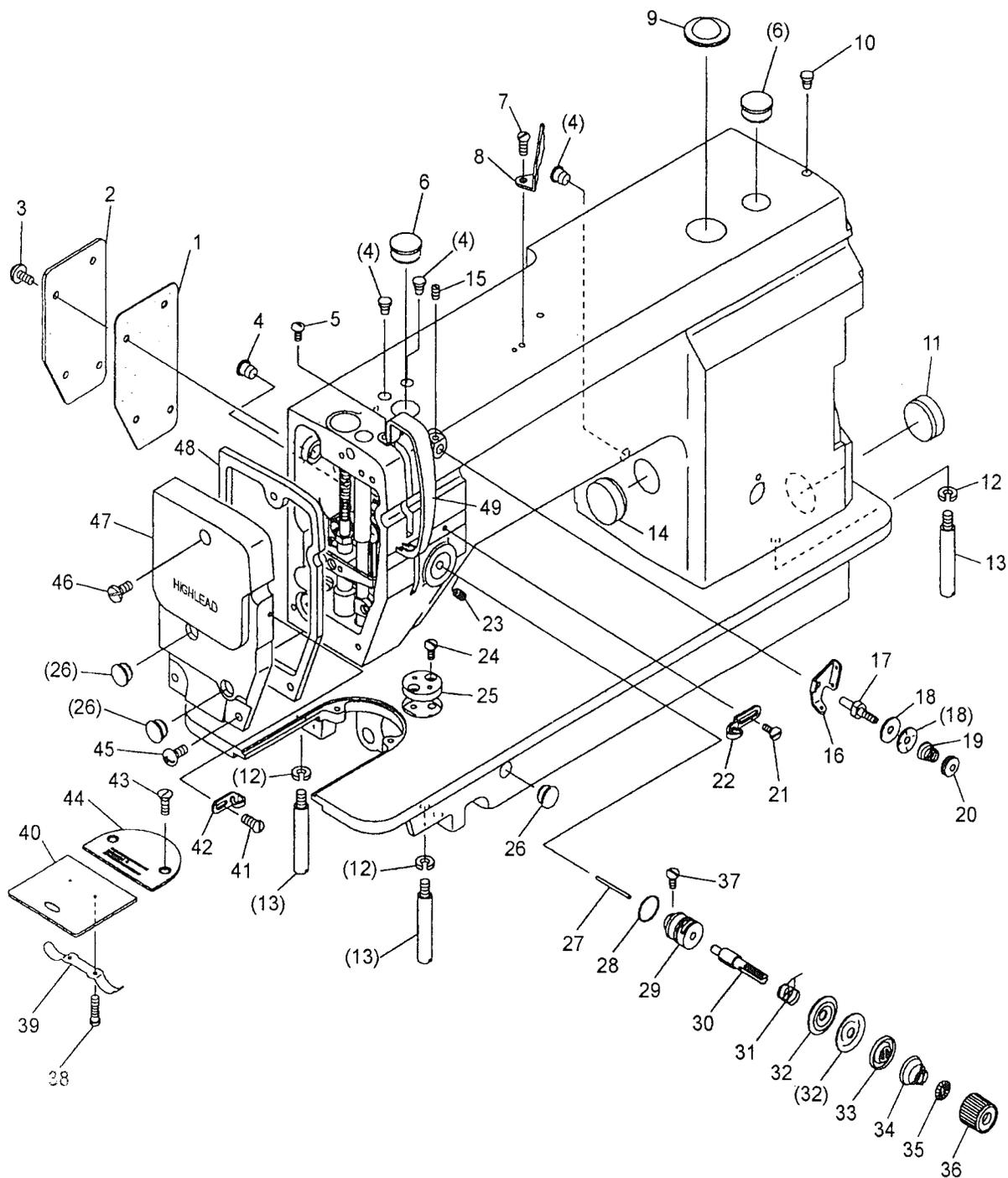

## A.ARM BED AND ITS ACCESSORIES

Fig. No.	Part No.	Description	GC0918-1-D	GC0918-1	Remarks
A01	HD544B8001	Arm side cover gasket	1	1	
A02	HD543B8001	Arm side cover	1	1	
A03	HA300B2170	Screw	4	4	11/64(40)×8
A04	HA300B2090	Rubber plug	5	5	φ 8.8
A05	HA707H0066	Screw	1	1	11/64(40)×8
A06	HA307B6673	Rubber plug	2	2	φ 19
A07	HA700B2060	Screw	1	1	11/64(40)×8
A08	HA700B2050	Thread guide	1	1	
A09	HA309B0069	Oil check window	1	1	
A10	HA300B2110	Rubber plug	1	1	φ 5.7
A11	HA300B2100	Rubber plug	1	1	φ 27
A12	H005008060	Spring washer	3	3	6
A13	HA100B2220	Leg	3	3	
A14	HA700B2120	Rubber plug	1	1	φ 20
A15	HA100B2110	Screw	1	1	11/64(40)×5.5
A16	HA710B0674	Thread guide	1	1	
A17	HA710B0673	Pre-tension stud	1	1	
A18	HA112B0693	Thread tension disc	2	2	
A19	HA710B0672	Pre-tension spring	1	1	
A20	HA710B0671	Pre-tension adjusting nut	1	1	11/64(40)
A21	HA106B0676	Screw	1	1	9/64(40)×6
A22	HA100B2140	Thread guide	1	1	
A23	HA300B2080	Set screw	1	1	15/64(28)×6
A24	HA300B2130	Screw	2	2	11/64(40)×5.5
A25	HA300B2140	Cloth guide plate	1	1	
A26	HA307B0674	Rubber plug	3	3	φ 11.8
A27	H6725B8001	Thread releasing pin	1	1	
A28	HA115B7011	O-ring	1	1	
A29	HA310B0703	Thread tension regulator bushing	1	1	
A30	HA115B0701	Thread tension stud	1	1	
A31	HA115B0706	Thread take-up spring	1	1	
A32	HA310B0705	Thread tension disc	2	2	
A33	HA310B0702	Thread tension rulsding disc	1	1	
A34	H3013B0701	Thread tension spring	1	1	
A35	HA115B7010	Thumb nut revolution stopper	1	1	
A36	HA310B0701	Thumb nut	1	1	1/4(40)
A37	HA115B0708	Screw	1	1	9/64(40)×4
A38	HA124B0713	Screw	2	2	3/32(56)×2.2
A39	HA324B0711	Plate spring for slide plate	1	1	
A40	HA124B0711	Slide plate	1	1	
A41	HA106B0676	Screw	1	1	9/64(40)×6
A42	HA106B0675	Thread guide	1	1	
A43	HA300B2190	Screw	2	2	11/64(40)×7

## A.ARM BED AND ITS ACCESSORIES

Fig. No.	Part No.	Description	GC0918-1-D	GC0918-1	Remarks
A44	HD546B8001	Needle plate	1	1	
A45	HA111G0683	Screw	1	1	11/64(40)×12
A46	H5731B8001	Screw	2	2	11/64(40)×16
A47	HD530B8001	Face plate	1	1	
A48	HD531B8001	Face plate gasket	1	1	
A49	HA700H2030	Thread take-up cover	1	1	

# B.SEWING MECHANISM

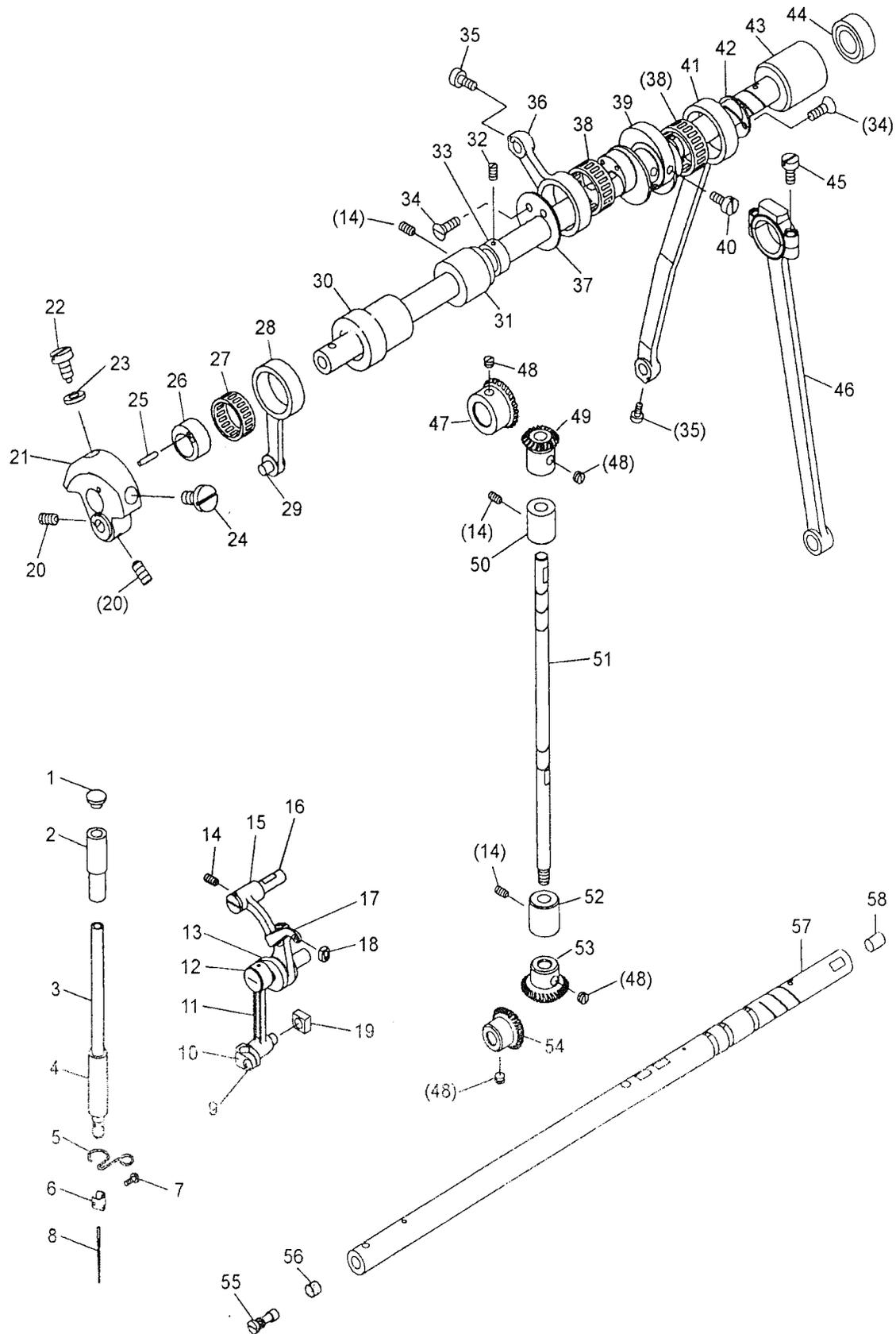

## B.SEWING MECHANISM

Fig. No.	Part No.	Description	GC0918-1-D	GC0918-1	Remarks
B01	HA300B2090	Rubber plug	1	1	φ 8.8
B02	HA100C2080	Needle bar bushing (Upper)	1	1	
B03	HD504G7101	Needle bar	1	1	
B04	HD513B8001	Needle bar bushing (Lower)	1	1	
B05	HD525B8001	Thread guide	1	1	
B06	HD507G8001	Thread guide	1	1	
B07	HA100C2170	Screw	1	1	1/8(44)×4.5
B08	HA100C2160	Needle	1	1	DB×1-2#14
B09	H2204C0651	Set screw	1	1	9/64(40)×6
B10	HA104C0658	Needle bar adaptor	1	1	
B11	HA304C0653	Needle bar link	1	1	
B12	HA104C0656	Set screw(Left-handed)	1	1	
B13	HD511G8001	Thread take-up crank	1	1	
B14	HA100C2020	Set screw	4	4	15/64(28)×9.5
B15	HA104C0652	Thread take-up lever link	1	1	
B16	HD509G7101	Hinge pin	1	1	
B17	HA1111C104	Thread take-up lever	1	1	
B18	HA704H0652	Oil shield cap	1	1	
B19	H6704H8001	Slide block	1	1	
B20	HA307C0662	Set screw	2	2	1/4(40)×6
B21	HD505C8001	Needle crank	1	1	
B22	HA100C2070	Screw	1	1	9/32(28)×14
B23	HA705C0662	O-ring	1	1	
B24	HA100C2060	Screw	1	1	9/32(28)×13
B25	HD512C8001	Pin	1	1	
B26	HD509C8001	Cam	1	1	
B27	HD510C8001	Needle bearing	1	1	
B28	HD508C8001	Crank rod	1	1	
B29	HD511C8001	Pin	1	1	
B30	HD514B8001	Upper shaft bushing (Left)	1	1	
B31	HA100D2040	Upper shaft bushing (Middle)	1	1	
B32	HA105D0662	Set screw	2	2	1/4(40)×4
B33	HA108G0661	Thrust collar	1	1	
B34	HA7311C306	Screw	6	6	3/16(28)×13
B35	HA7311C806	Screw	2	2	11/64(40)×7
B36	HD540C8001	Crank rod	1	1	
B37	HD539C8001	Thrust washer	1	1	
B38	H30211C206	Needle bearing	2	2	
B39	HD535C8001	Feed drive eccentric cam	1	1	
B40	HA110D0672	Screw	2	2	15/64(28)×12
B41	HD536C8001	Crank rod	1	1	
B42	H30211C406	Thrust washer	1	1	
B43	HA300D2020	Upper shaft bushing (Right)	1	1	

## B.SEWING MECHANISM

Fig. No.	Part No.	Description	GC0918-1-D	GC0918-1	Remarks
B44	HA306D0066	Oil seal	1	1	
B45	HA304G0656	Screw	2	2	3/16(28)×15
B46	HD547C8001	Crank rod	1	1	
B47	HA113D2112	Bevel gear for upper shaft	1	1	
B48	HA108C0663	Set screw	8	8	1/4(40)×7
B49	HA113D2122	Bevel gear for vertical shaft(Upper)	1	1	
B50	HA100D2110	Vertical shaft bushing (Upper)	1	1	
B51	HA113D0691	Vertical shaft	1	1	
B52	HA100D2110	Vertical shaft bushing (Lower)	1	1	
B53	HA113D2222	Bevel gear for vertical shaft(Lower)	1	1	
B54	HA113D2212	Bevel gear for lower shaft	1	1	
B55	HA704C0021	Oil amount adjusting pin assy.	1	1	
B56	HA704C0653	Felt	1	1	
B57	HD527C8001	Upper shaft	1	1	
B58	HA104D0652	Rubber plug	1	1	φ 7.4

# C.FEEDING AND FEED LIFTING & ROTATING HOOK SHAFT MECHANISM

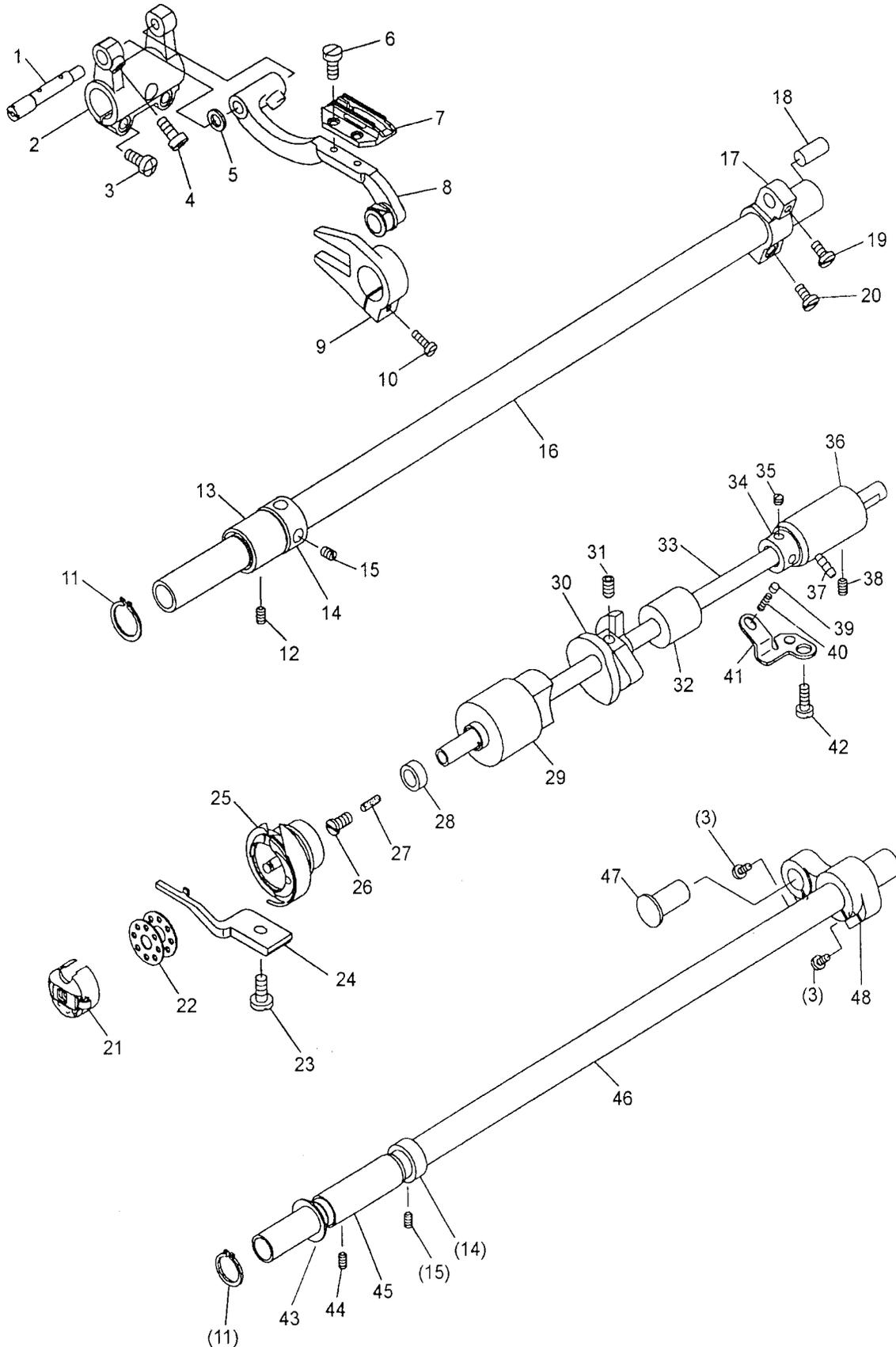

## C.FEEDING AND FEED LIFTING & ROTATING HOOK SHAFT MECHANISM

Fig. No.	Part No.	Description	GC0918-1-D	GC0918-1	Remarks
C01	HA705J0654	Shaft for feed bar (Eccentric)	1	1	
C02	HA104G0011	Feed rock shaft crank (Left)	1	1	
C03	HA104G0012	Screw	4	4	3/16(28)×12
C04	HA300C2030	Screw	1	1	11/64(40)×8
C05	HA104G0656	Washer	1	1	
C06	HA104G0654	Screw	2	2	1/8(44)×6
C07	HD505J8001	Drop feed dog	1	1	
C08	HA705J0031	Feed bar assy.	1	1	
C09	HA7111K104	Feed lifting rock shaft fork	1	1	
C10	HA111G0683	Screw	1	1	11/64(40)×12
C11	H007009150	Retaining ring C-type	2	2	15
C12	HA305E0662	Screw	1	1	15/64(28)×3.5
C13	HA100G2040	Bushing for feed rock shaft (Left)	1	1	
C14	HA108G0661	Thrust collar	2	2	
C15	HA105D0662	Set screw	4	4	1/4(40)×4
C16	HA300G2050	Feed rock shaft	1	1	
C17	HA7311C706	Feed rock shaft crank (Right)	1	1	
C18	HA706C11B2	Feed rock shaft crank pin	1	1	
C19	HA7311C806	Screw	1	1	11/64(40)×7
C20	HA7311C606	Screw	1	1	11/64(40)×15
C21	HA119E0070	Bobbin case assy.	1	1	
C22	H2604D8001	Bobbin	1		
C22	HA100E2170	Bobbin		1	
C23	HA100E2150	Screw	1		11/64(40)×10
C24	HA300E2050	Hook positioner	1		
C25	HA707E0067	Rotary hook assy.	1		
C25	HA115E0069	Rotary hook assy.		1	
C26	HA1111E104	Felter screw	1	1	3/16(32)×9
C27	HA1111E204	Oil felt for lower shaft	1	1	
C28	HA700E2030	Oil seal	1	1	
C29	HA704B0654	Lower shaft bushing (Left)	1		
C29	HA100E2040	Lower shaft bushing (Left)		1	
C30	HA710E0691	Thread trimmer cam	1		
C31	HA710E0692	Socket set screw	2		1/4(40)×10
C32	HA704B0653	Lower shaft bushing (Middle)	1		
C33	HA704E0651	Lower shaft	1	1	
C34	HA305E0661	Thrust collar	1	1	
C35	HA305E0662	Set screw	2	2	11/64(40)×3.7
C36	HA311E0671	Lower shaft bushing (Right)	1	1	
C37	HA110E0672	Oil pipe for lower shaft bushing	1	1	
C38	HA100C2020	Set screw	1	1	15/64(28)×9.5
C39	HA300E2100	Plunger	1	1	
C40	HA300E2110	Coil spring	1	1	

### C.FEEDING AND FEED LIFTING & ROTATING HOOK SHAFT MECHANISM

Fig. No.	Part No.	Description	GC0918-1-D	GC0918-1	Remarks
C41	HA100E2100	Guide plate	1	1	
C42	HA104F0654	Screw	1	1	15/64(28)×10
C43	HA100G2130	Thrust washer	1	1	
C44	HA100C2020	Set screw	1	1	15/64(28)×9.5
C45	HA100G2120	Bushing for feed lifting rock shaft	1	1	
C46	HA704K0652	Feed lifting rock shaft	1	1	
C47	HA100G2070	Pin	1	1	
C48	HD505K8001	Feed lifting rock shaft crank(Right)	1	1	

# D.STITCH REGULATOR MECHANISM

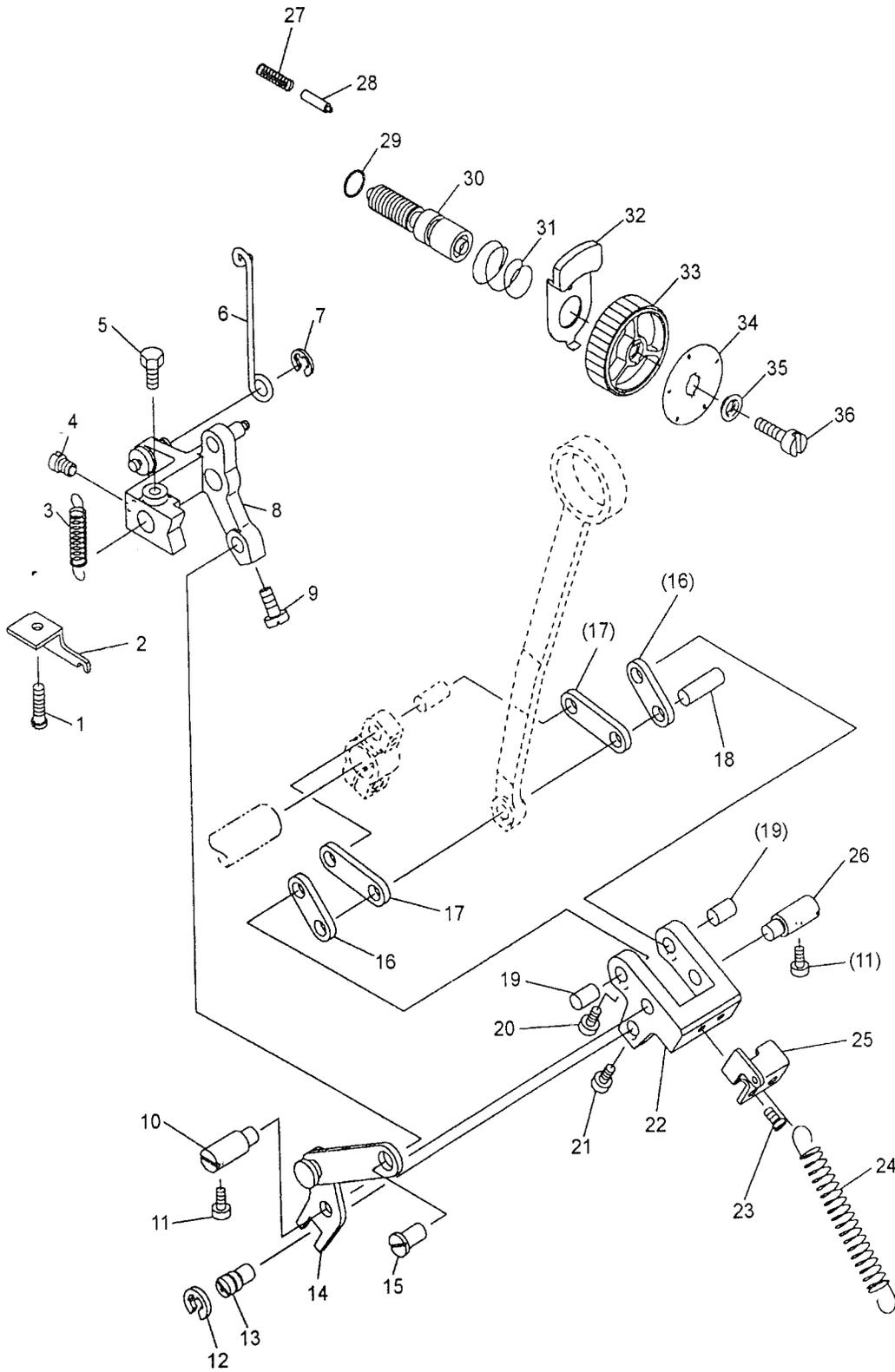

# D.STITCH REGULATOR MECHANISM

Fig. No.	Part No.	Description	GC0918-1-D	GC0918-1	Remarks
D01	HA300C2030	Screw	1	1	11/64(40)×8
D02	HD548B8001	Spring holder	1	1	
D03	HD521F8001	Coil spring	1	1	
D04	H3200F2020	Screw	1	1	15/64(28)×12
D05	HD515F8001	Bolt	1	1	15/64(28)×12.5
D06	HD522F8001	Reverse pull bar	1	1	
D07	H007013050	Retaining ring E-type	1	1	5
D08	HD506F7101	Feed adjusting cam	1	1	
D09	HA7311C806	Screw	1	1	11/64(40)×7
D10	HD531C8002	Feed regulator stud	1	1	
D11	HA111G0683	Screw	2	2	11/64(40)×12
D12	H007013060	Retaining ring E-type	1	1	6
D13	HD549C8001	Eccentric stud	1	1	
D14	HD510F7101	Feed regulator link assy.	1	1	
D15	HD514F8001	Pin	1	1	
D16	HA706C1191	Link	2	2	
D17	HA706C1192	Link	2	2	
D18	HA706C11B1	Link stud	1	1	
D19	HA7311CE06	Link stud	2	2	
D20	H3207F0672	Screw	2	2	11/64(40)×8.5
D21	HA7311C806	Screw	1	1	11/64(40)×7
D22	HD537C8001	Stitch length adjusting crank	1	1	
D23	HA700F2100	Screw	2	2	11/64(40)×7
D24	HD533C8001	Coil spring	1	1	
D25	HD538C8001	Spring holder	1	1	
D26	HD531C8001	Feed regulator shaft	1	1	
D27	HA100F2090	Coil spring	1	1	
D28	HA700F2030	Stopper pin	1	1	
D29	HA109F0674	O-ring	1	1	
D30	HA720F0681	Screw bar	1	1	
D31	HA720F0687	Coil spring	1	1	
D32	HA720F0683	Stopper pin veleasing lever	1	1	
D33	HA7421F120	Dial	1	1	
D34	HD520F8001	Stitch length indicating plate	1	1	
D35	HA720F0685	Bushing	1	1	
D36	HA720F0686	Screw	1	1	3/16(28)×12

# E.TOP FEED ROCK SHAFT MECHANISM

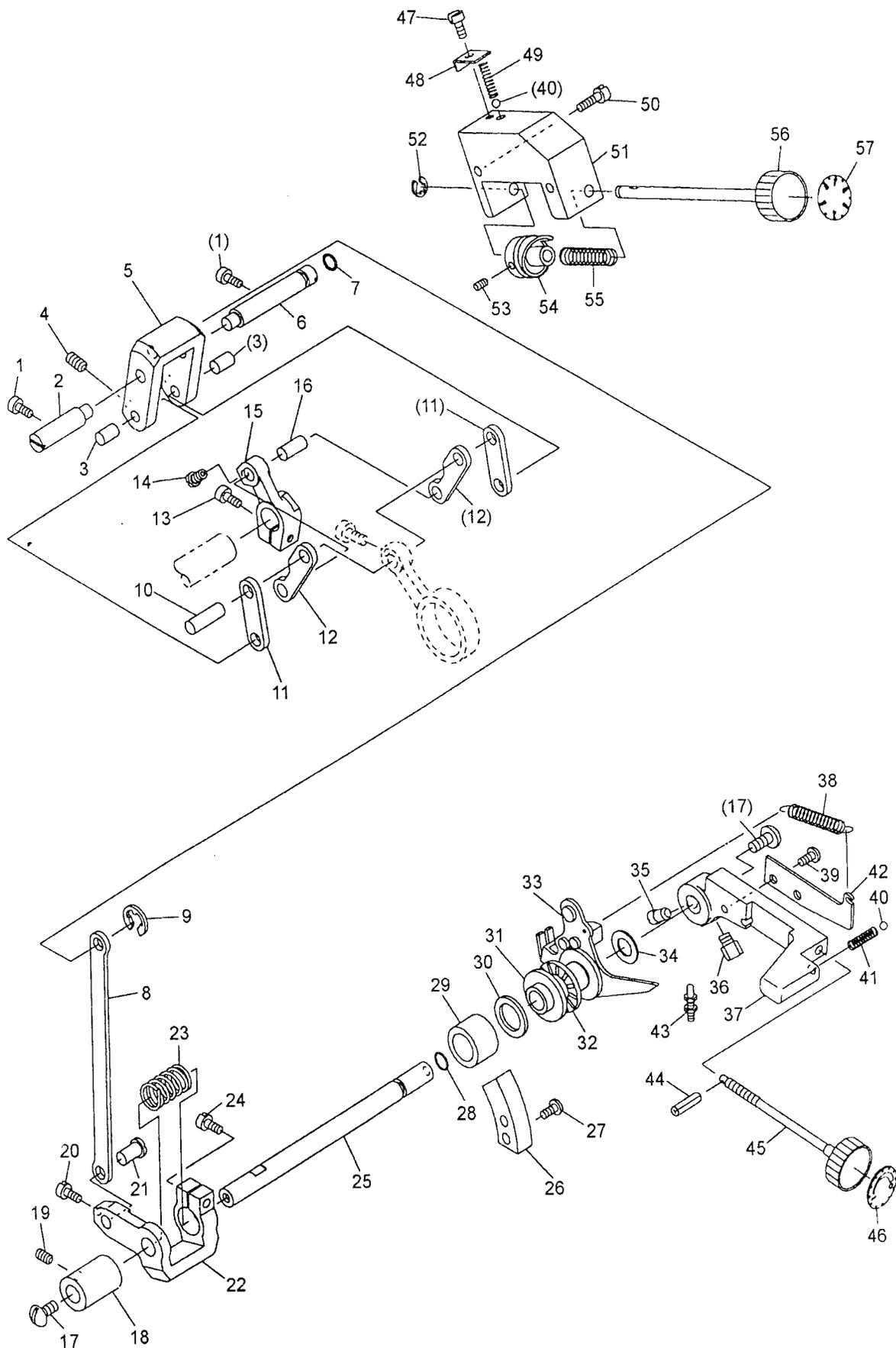

## E.TOP FEED ROCK SHAFT MECHANISM

Fig. No.	Part No.	Description	GC0918-1-D	GC0918-1	Remarks
E01	HA111G0683	Screw	2	2	11/64(40)×12
E02	HD528C8001	Feed regulator stud	1	1	
E03	HA7311CE06	Link stud	2	2	
E04	HD544C8001	Socket screw	2	2	11/64(40)×5
E05	HD541C7101	Top stitch length adjusting crank assy.	1	1	
E06	HD530C8001	Feed regulator stud	1	1	
E07	HA705C0662	O-ring	1	1	
E08	HD525F8001	Link	1	1	
E09	H007013050	Retaining ring E-type	1	1	5
E10	HA706C11B1	Link stud	1	1	
E11	HA706C1192	Link	2	2	
E12	HD545C8001	Link	2	2	
E13	HA304G0656	Screw	1	1	3/16(28)×15
E14	HA7311C806	Screw	1	1	11/64(40)×7
E15	HD546C8001	Top feed rock shaft crank	1	1	
E16	HA706C11B2	Feed rock shaft crank pin	1	1	
E17	HA113F0683	Screw	2	2	3/16(28)×6.5
E18	HD517B8001	Feed reverse shaft bushing	1	1	
E19	HA100B2110	Screw	1	1	11/64(40)×5.5
E20	H3207F0672	Screw	1	1	11/64(40)×8.5
E21	HD514F8001	Pin	1	1	
E22	HD524F8001	Top feed arm	1	1	
E23	HD526F8001	Coil spring	1	1	
E24	HA304G0656	Screw	1	1	3/16(28)×15
E25	HD504F8001	Feed reverse shaft	1	1	
E26	HD547F8001	Top feeding scale plate	1	1	
E27	HA300B2130	Screw	2	2	11/64(40)×5.5
E28	HA113F3022	O-ring	1	1	
E29	HD515B8001	Needle bearing	1	1	
E30	H6748B8001	Oil seal	1	1	
E31	HD527F8001	Thrust washer	1	1	
E32	HD410H8001	Thrust bearing	1	1	
E33	HD530F8001	Top feed lever	1	1	
E34	HD535F8001	Washer	1	1	
E35	H3200F2020	Screw	1	1	15/64(28)×12
E36	HD515F8001	Bolt	1	1	15/64(28)×12.5
E37	HD537F8001	Stitch adjusting lever	1	1	
E38	HD546F8001	Coil spring	1	1	
E39	HA100C2190	Screw	2	2	11/64(40)×8
E40	HE00001050	Ball	2	2	5
E41	HD538F8001	Spring	1	1	
E42	HD545F8001	Spring holder	1	1	
E43	HD549B7101	Stopper assy.	1	1	

## E.TOP FEED ROCK SHAFT MECHANISM

Fig. No.	Part No.	Description	GC0918-1-D	GC0918-1	Remarks
E44	H609015060	Spring pin	1	1	φ 1.5×6
E45	HD542F8001	Top feeding dial	1	1	
E46	HD544F8001	Top indicating plate	1	1	
E47	HA700F2100	Screw	1	1	11/64(40)×7
E48	HD556F8001	Spring holder	1	1	
E49	HD555F8001	Coil spring	1	1	
E50	HD557F8001	Screw	2	2	11/64(40)×27
E51	HD552F8001	Ruffling stopper base	1	1	
E52	H007013040	Retaining ring E-type	1	1	4
E53	HA100B2110	Set screw	2	2	11/64(40)×6
E54	HD554F8001	Ruffling stopper cam	1	1	
E55	HD553F8001	Coil spring	1	1	
E56	HD541F8001	Ruffling stopper dial	1	1	
E57	HD558F8001	Ruffling indicating plate	1	1	

# F.PRESSER FOOT MECHANISM

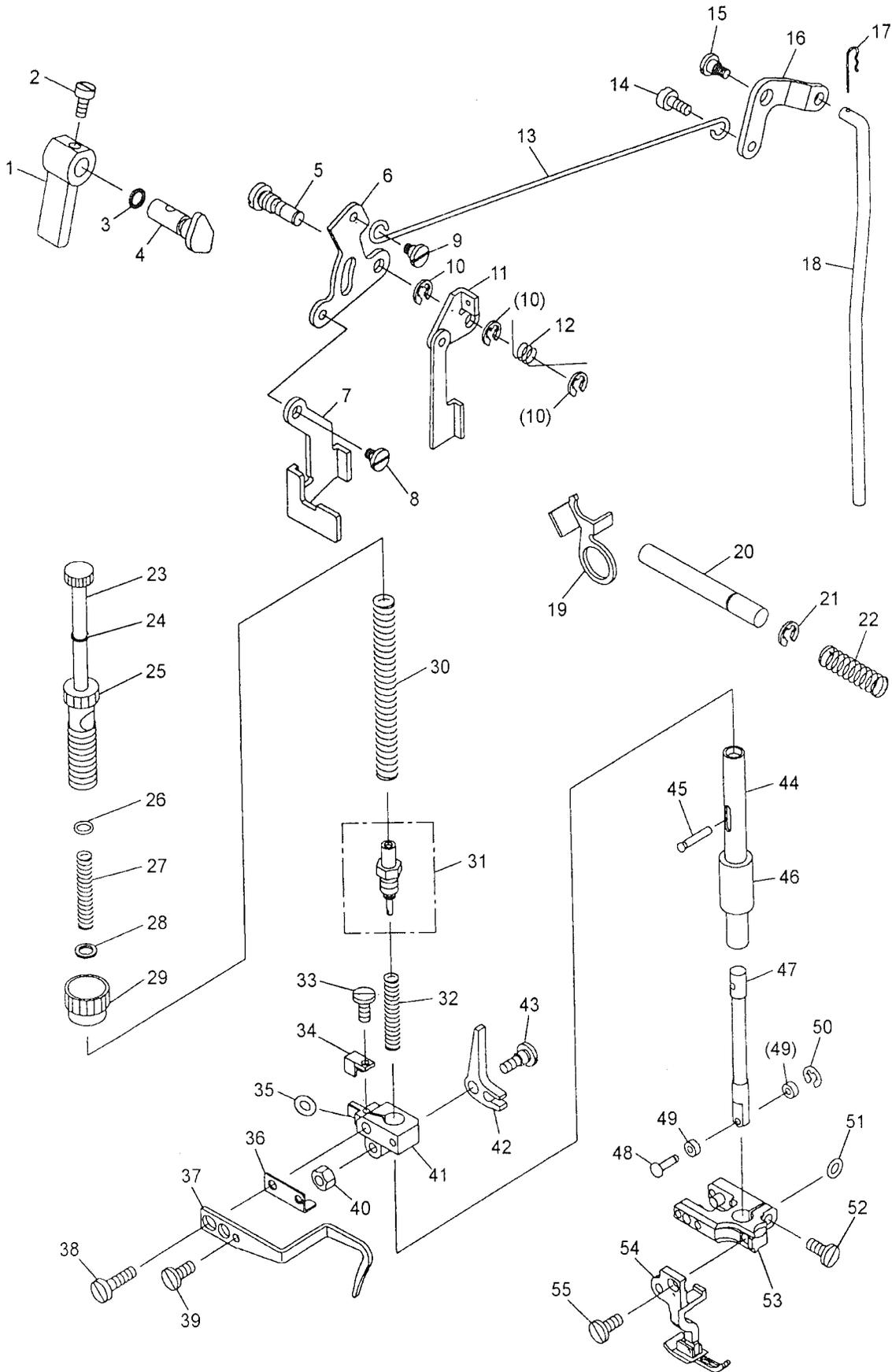

## F.PRESSER FOOT MECHANISM

Fig. No.	Part No.	Description	GC0918-1-D	GC0918-1	Remarks
F01	H1204F0651	Presser foot lifter lever	1	1	
F02	HA300B2170	Screw	1	1	11/64(40)×10
F03	HA300H2080	O-ring	1	1	
F04	H6728J8001	Lift cam	1	1	
F05	HD515H8001	Stud screw	1	1	5/16(24)×8
F06	HD510H8001	Presser up lever (Left)	1	1	
F07	HD513H8001	Pull-up plate	1	1	
F08	HD511H8002	Shoulder screw	1	1	11/64(40)×2.6
F09	HD511H8001	Shoulder screw	1	1	11/64(40)×3.5
F10	H007013050	Retaining ring E-type	3	3	5
F11	HD520H7101	Tension release link assy.	1	1	
F12	HD524H8001	Spring	1	1	
F13	HA107H0663	Knee lifter rod	1	1	
F14	HA107H0662	Stud screw	1	1	3/16(28)×3.5
F15	HA100H2050	Stud bolt	1	1	15/64(40)×6.5
F16	HD517H8001	Knee lifter lever (right)	1	1	
F17	H4739E8001	Snap pin	1	1	6
F18	HD518H8001	Knee lifter connecting rod	1	1	
F19	HD521C8001	Tension release plate	1	1	
F20	HD526H8001	Tension release pin	1	1	
F21	H007013030	Retaining ring E-type	1	1	3
F22	H6732J8001	Tension release pin spring	1	1	
F23	HD506Q8001	Presser adjusting screw guide	1	1	
F24	HD507Q8001	Snap ring	1	1	
F25	HD505Q8001	Presser adjusting screw	1	1	
F26	HD508Q8001	Washer	1	1	
F27	HD509Q8001	Top feed adjusting knob spring	1	1	
F28	HD510Q8001	Washer	1	1	
F29	HA117H0692	Thumb nut	1	1	
F30	HD511Q8001	Presser spring	1	1	
F31	HD518Q7101	Cap nut assy.	1	1	
F32	HD527Q8001	Top feed spring	1	1	
F33	HA104G0654	Screw	1	1	1/8(44)×6
F34	HD515Q8001	bracket guide	1	1	
F35	HD523Q8001	Washer	1	1	5
F36	HD522Q8001	Bracket plate	1	1	
F37	HD526Q8001	Upper thread guide	1	1	
F38	HA7311C606	Screw	1	1	11/64(40)×15
F39	H2000I2050	Screw	1	1	9/64(40)×6
F40	HA104G0658	Nut	1	1	3/16(32)
F41	HD514Q8001	Presser bar guide bracket	1	1	
F42	HD524Q8001	Bellcrank	1	1	
F43	HD525Q8001	Stud screw	1	1	3/16(32)×10

# F.PRESSER FOOT MECHANISM

Fig. No.	Part No.	Description	GC0918-1-D	GC0918-1	Remarks
F44	HD517Q8001	Presser bar	1	1	
F45	HD528Q8001	Top feed lifting pin	1	1	
F46	HD511B8001	Presser bar bushing	1	1	
F47	HD530Q8001	Top feed lifting bar	1	1	
F48	HD531Q8001	Roller pin	1	1	
F49	HD532Q8001	Roller	2	2	
F50	H007013025	Retaining ring E-type	1	1	2.5
F51	HD523Q8002	Washer	1	1	5
F52	H4100B2260	Screw	1	1	3/16(28)×10
F53	HD541Q8001	Presser bar base	1	1	
F54	HD550Q7101	Presser foot	1	1	
F55	HA104G0012	Screw	1	1	3/16(28)×12

# G.TOP FEED MECHANISM

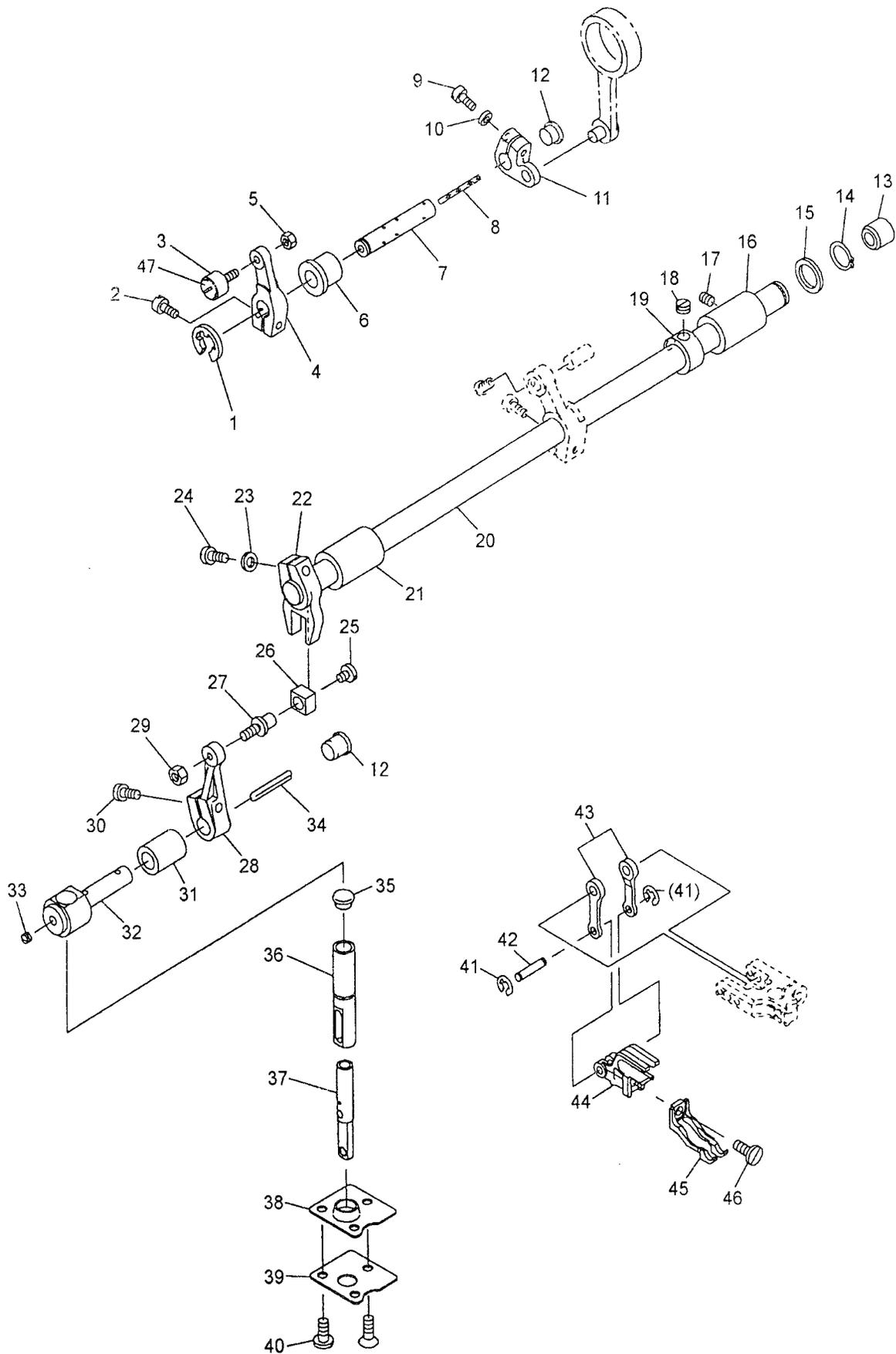

# G.TOP FEED MECHANISM

Fig. No.	Part No.	Description	GC0918-1-D	GC0918-1	Remarks
G01	H007013080	Retaining ring E-type	1	1	8
G02	HA104G0012	Screw	1	1	3/16(28)×12
G03	HD519C8001	Roller	1	1	
G04	HD523C8001	Top feed vertical arm (Front)	1	1	
G05	H003002040	Nut	1	1	M4
G06	HD521B8001	Top feed vertical shaft bushing	1	1	
G07	HD515C8001	Top feed vertical shaft	1	1	
G08	HA304I0653	Oil wick	1	1	
G09	H4100B2260	Screw	1	1	3/16(28)×10
G10	HD520C8001	Washer	1	1	
G11	HD518C8001	Top feed vertical arm (Rear)	1	1	
G12	HD513C8001	Rubber plug	2	2	φ 10.5
G13	H3000B2110	Rubber plug	1	1	φ 21.5
G14	H007009120	Retaining ring C-type	1	1	12
G15	H3010D0674	Washer	1	1	
G16	H3010D0673	Upper horizontal bushing (Right)	1	1	
G17	H3230K0751	Set screw	1	1	11/64(40)×10
G18	H7239D8001	Set screw	2	2	1/4(40)×3
G19	H3011D0681	Thrust collar	1	1	
G20	HD505I8001	Upper horizontal rocker shaft	1	1	
G21	HD522B8001	Upper horizontal bushing (Left)	1	1	
G22	HD509I8001	Upper horizontal forked arm	1	1	
G23	HD520C8001	Washer	1	1	
G24	HA104G0012	Screw	1	1	3/16(28)×12
G25	HD514I8001	Screw	1	1	11/64(40)×5.5
G26	HD513I8001	Square block	1	1	
G27	HD512I8001	Square block stud	1	1	
G28	HD511I8001	Upper rocker crank	1	1	
G29	HD515I8001	Nut	1	1	3/16(28)
G30	HA304G0656	Screw	1	1	3/16(28)×15
G31	HD520B8001	Upper rocker shaft bushing	1	1	
G32	HD517I8001	Upper rocker shaft	1	1	
G33	HA305E0662	Set screw	1	1	
G34	HD518I8001	Oil wick	1	1	φ 8.8
G35	HA300B2090	Rubber plug	1	1	
G36	HD535Q8001	Top feed bar bushing	1	1	
G37	HD536Q7101	Top feed bar	1	1	
G38	HD539Q8001	Gasket	1	1	
G39	HD519I8001	Gasket plate	1	1	
G40	HD520I8001	Screw	3	3	11/64(40)×8.2
G41	H007013035	Retaining ring E-type	2	2	3.5
G42	HD546Q8001	Pin	1	1	
G43	HD544Q8001	Link assy.	1	1	

## G.TOP FEED MECHANISM

Fig. No.	Part No.	Description	GC0918-1-D	GC0918-1	Remarks
G44	HD548Q8001	Top feed dog base	1	1	
G45	HD549Q8001	Top feed dog	1	1	
G46	HA700B2060	Screw	1	1	11/64(40)×8
G47	HD524Q8001	Roller stud	1	1	

# H.KNIFE ACTUATING MECHANISM

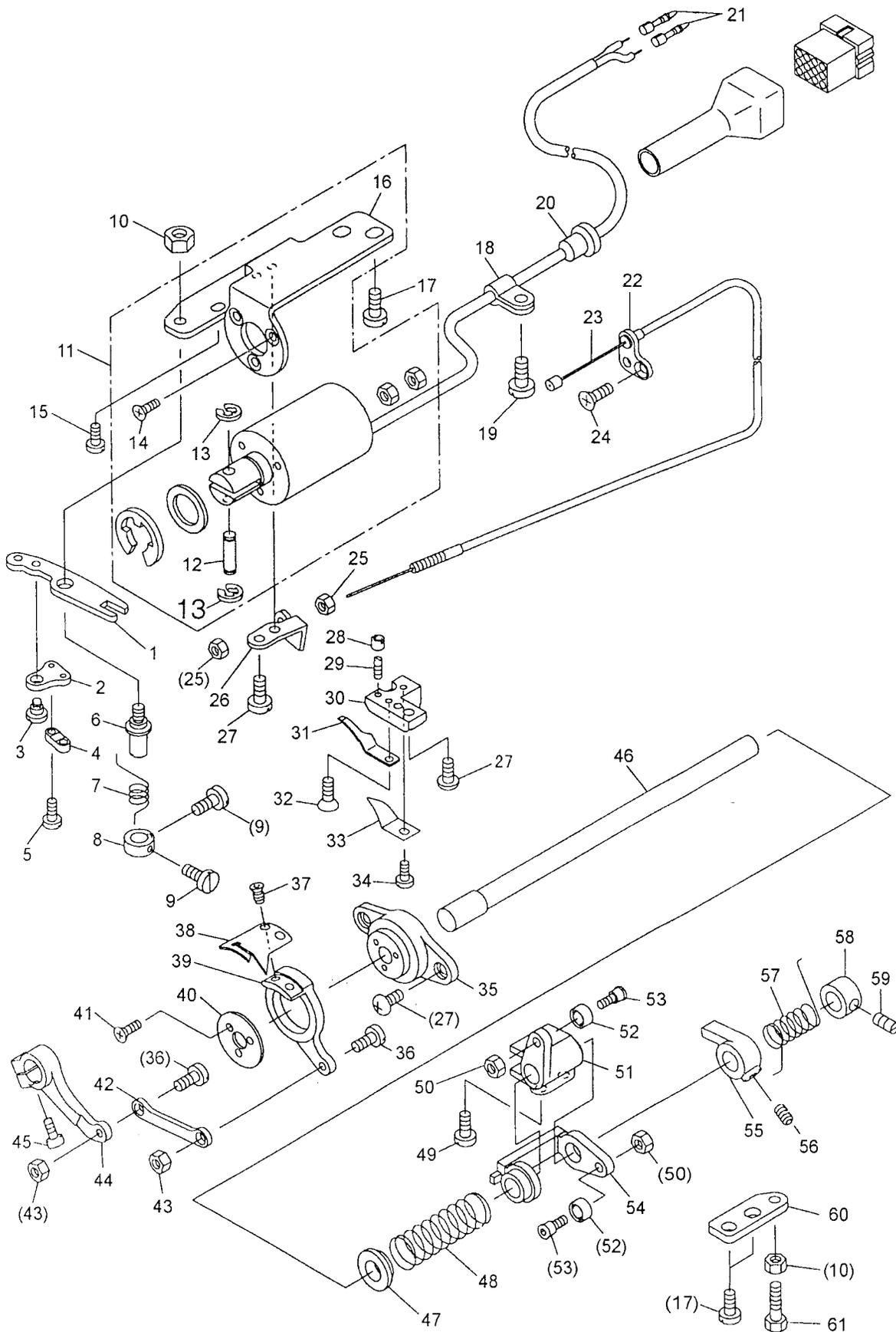

# H.KNIFE ACTUATING MECHANISM

Fig. No.	Part No.	Description	GC0918-1-D	GC0918-1	Remarks
H01	HA712N0698	Thread trimmer driving lever	1		
H02	HA712N6910	Flexible wire holder	1		
H03	HA712N0699	Stud screw	1		11/64(40)×3.3
H04	HA712N6911	Flexible wire presser	1		
H05	HA712N6912	Screw	2		1/8(44)×7
H06	HA712N0695	Stud screw	1		15/64(28)×7.5
H07	HA712N0697	Trimming lever spring	1		
H08	HA712N0696	Spring support collar	1		
H09	HA7311CC06	Screw	2		9/64(40)×6.5
H10	HA710N0683	Nut	2		15/64(28)
H11	HA7511N112	Thread trimming solenoid	1		
H12	HA712N0692	Pin	1		
H13	H007013040	Retaining ring E-type	2		4
H14	HS90011406	Screw	3		M4×6
H15	HA100E2150	Screw	1		11/64(40)×10
H16	HA7511N212	Solenoid bracket	1		
H17	HA700N0080	Screw	4		15/64(28)×12
H18	HA708P0668	Cord holder	1		
H19	HA300B2170	Screw	1		11/64(40)×8
H20	HA704O0657	Rubber bushing	1		
H21	HA7641B319	Terminal pin (male)	2		
H22	HD518N8001	Flexible wire plate	1		
H23	HA713N0702	Flexible wire	1		
H24	HA300B2190	Screw	1		11/64(40)×7
H25	H003002050	Nut	2		M5
H26	HA712N6913	Holder	1		
H27	HA300C2030	Screw	5		11/64(40)×8
H28	HA7121N704	Nut	1		11/64(40)
H29	HA7121N604	Set screw	1		9/64(40)×8.5
H30	HA7121N104	Bracket for fixed blade	1		
H31	HA7121N204	Fixed blade	1		
H32	HA7121N304	Screw	1		11/64(40)×9
H33	HA7121N404	Thread finger	1		
H34	HA7311CH06	Screw	1		9/64(40)×8
H35	HA704N1111	Knife holding bracket saddle	1		
H36	HA7111N204	Stud screw	2		11/64(40)×6.2
H37	HA7111N704	Screw	2		11/64(40)×7
H38	HA7111N804	Movable knife (Left)	1		
H39	HA704N1112	Knife base (Left)	1		
H40	HA704N1113	Thrust washer	1		
H41	HA704N1114	Screw	3		1/8(44)×6
H42	HA7111N404	Link	1		
H43	HA7111N304	Nut	2		11/64(40)

# H.KNIFE ACTUATING MECHANISM

Fig. No.	Part No.	Description	GC0918-1-D	GC0918-1	Remarks
H44	HA7111N604	Knife driving crank	1		
H45	HA719B7011	Screw	1		11/64(40)×13
H46	HA700N0020	Knife driving shaft	1		
H47	HA700N0050	Bushing	1		
H48	HA700N0040	Coil spring	1		
H49	HA113F0684	Screw	1		15/64(28)×8.5
H50	HA706N0663	Nut	2		3/16(28)
H51	HA7211N106	Cam follower crank (1)	1		
H52	HA7221N106	Roller	2		
H53	HA7221N206	Roller stud	2		
H54	HA7211N206	Cam follower crank (2)	1		
H55	HA709N0671	Stopper	1		
H56	HA113F0684	Set screw	1		1/4(40)×7
H57	HA700N0110	Coil spring	1		
H58	HA715N0711	Collar	1		
H59	HA105D0662	Set screw	1		1/4(40)×4
H60	HA710N0682	Lever stopper plate	1		
H61	HA7411N110	Bolt	1		15/64(28)×23

# I.TOUCH BACK MECHANISM & DETECTOR MECHANISM

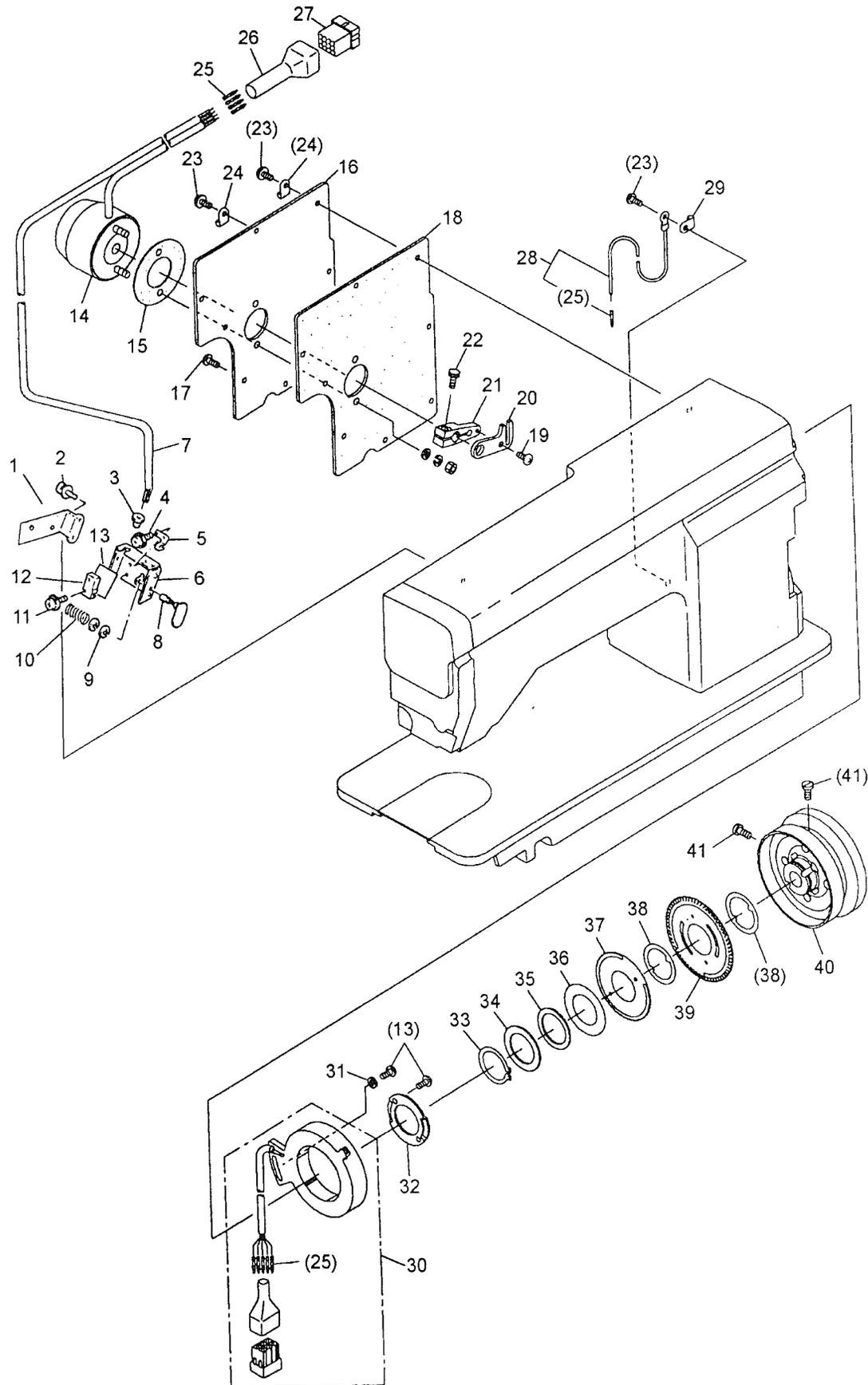

# I.TOUCH BACK MECHANISM & DETECTOR MECHANISM

Fig. No.	Part No.	Description	GC0918-1-D	GC0918-1	Remarks
101	HD552B8001	Bracket	1		
102	HA7221P508	Screw	2		
103	HA704O0657	Rubber plug	1		
104	HA704O0659	Screw	2		M2×3
105	HA704O0654	Spring plate	1		
106	H2205I0661	Bracket for touch switch	1		
107	HD553B7101	Cord assy.	1		
108	HA7121O104	Push button	1		
109	H007013030	Retaining ring E-type	2		3
110	HA704O0653	Coil spring	1		
111	HA704O6510	Screw	2		M2×8
112	HA704O0655	Micro switch	1		
113	HA704O0658	Insulator seat	1		
114	HD536B8001	Solenoid	1		
115	HD535B8001	Gasket	1		
116	HD533B8001	Arm side cover	1		
116	HG513B8001	Arm side cover		1	
117	HA300B2170	Screw	4	8	11/64(40)×8
118	HD534B8001	Gasket	1	1	
119	HA100E2150	Screw	1		11/64(40)×10
120	HD539B8001	Reverse plate	1		
121	HD537B8001	Reverse driving crank	1		
122	H4949L8001	Bolt	1		15/64(28)×13
123	HA300B2160	Screw	4		11/64(40)×10
124	HA708P0668	Cord holder	2		
125	HA7641B319	Terminal pin (Male)	11		
126	HA712Q0069	Connector cap	1		
127	HA700Q0010	Nylon connector 12-pole	1		
128	HA705Q0065	Ground wire	1		
129	H4922L8001	Cord holder	1		
130	HA703R0065	Detector bracket assy.	1		
131	HA703R0067	Washer	1		
132	HA703R0066	Detector bracket supporter	1		
133	H007009300	Retaining ring C-type	1		30
134	HA700R0060	Washer	1		30
135	HA700R0050	Supporter spring	1		
136	HA700R0040	Spacer	1		
137	HA700R0020	Speed command disc (Up)	1		
138	HA700R0030	Spacer	2		
139	HA700R0010	Speed command disc (Down)	1		
140	HD505P8001	Pully	1		
140	HA110D0671	Pully		1	
141	HA110D0672	Screw	2	2	15/64(28)×12

# J.OIL LUBRICATION MECHANISM

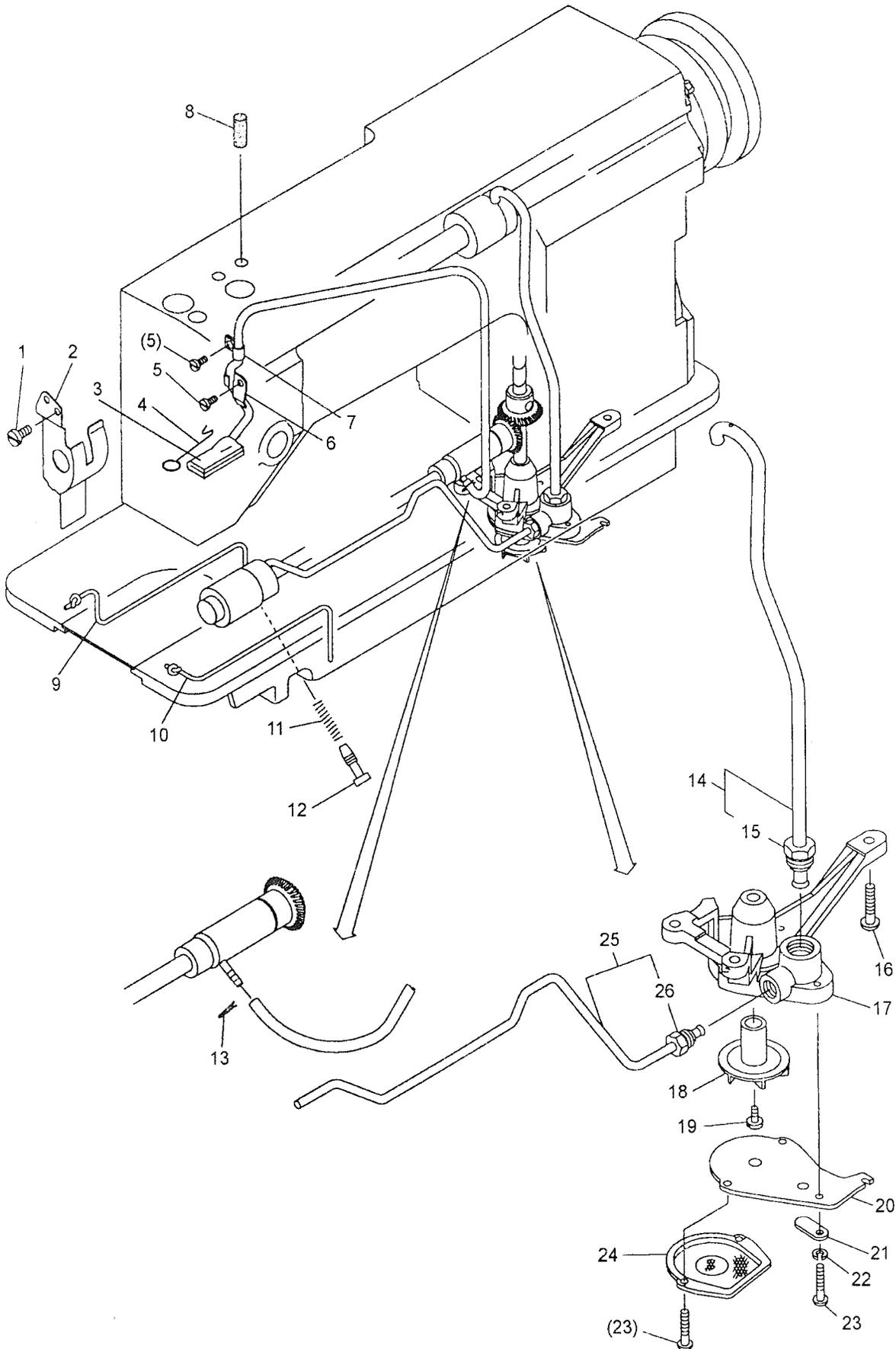

# J.OIL LUBRICATION MECHANISM

Fig. No.	Part No.	Description	GC0918-1-D	GC0918-1	Remarks
J01	HA300C2030	Screw	2	2	11/64(40)×8
J02	HA716B0069	Arm oil shield assy.	1	1	
J03	H3006L0065	Oil return felt assy.	1	1	
J04	H3000L0020	Felt holder	1	1	
J05	HA300C2030	Screw	2	2	11/64(40)×7
J06	HD511M8001	Holder	1	1	
J07	HA708P0668	Holder	1	1	
J08	HA700B2150	Oil felt	1	1	
J09	HA304G0655	Oil wick	1	1	
J10	HA305G0664	Oil wick	1	1	
J11	HA100E2060	Coil spring	1	1	
J12	HA300E2030	Oil adjusting screw	1	1	15/64(28)×7
J13	HA300I2030	Oil return tube clip	1	1	
J14	HA116I0068	Upper shaft oil tube assy.	1	1	
J15	HA116I0682	Oil tube lock bushing	1	1	
J16	HA100I2090	Screw	3	3	11/64(40)×13
J17	HA100I2010	Oil pump	1	1	
J18	HA100I2020	Oil pump impeller	1	1	
J19	HA100I2030	Screw	1	1	1/8(44)×8
J20	HA700L0030	Oil pump impeller cover	1	1	
J21	HA100I2070	Oil adjusting plate	1	1	
J22	HA100I2050	Spring washer	1	1	3.5
J23	HA100I2040	Screw	3	3	1/8(44)×13
J24	HA111I0065	Oil pump filter	1	1	
J25	HA707L0065	Lower shaft oil tube assy.	1	1	
J26	HA113I0661	Oil tube lock bushing	1	1	

# K.INTERMITTENT RUFFLING MECHANISM

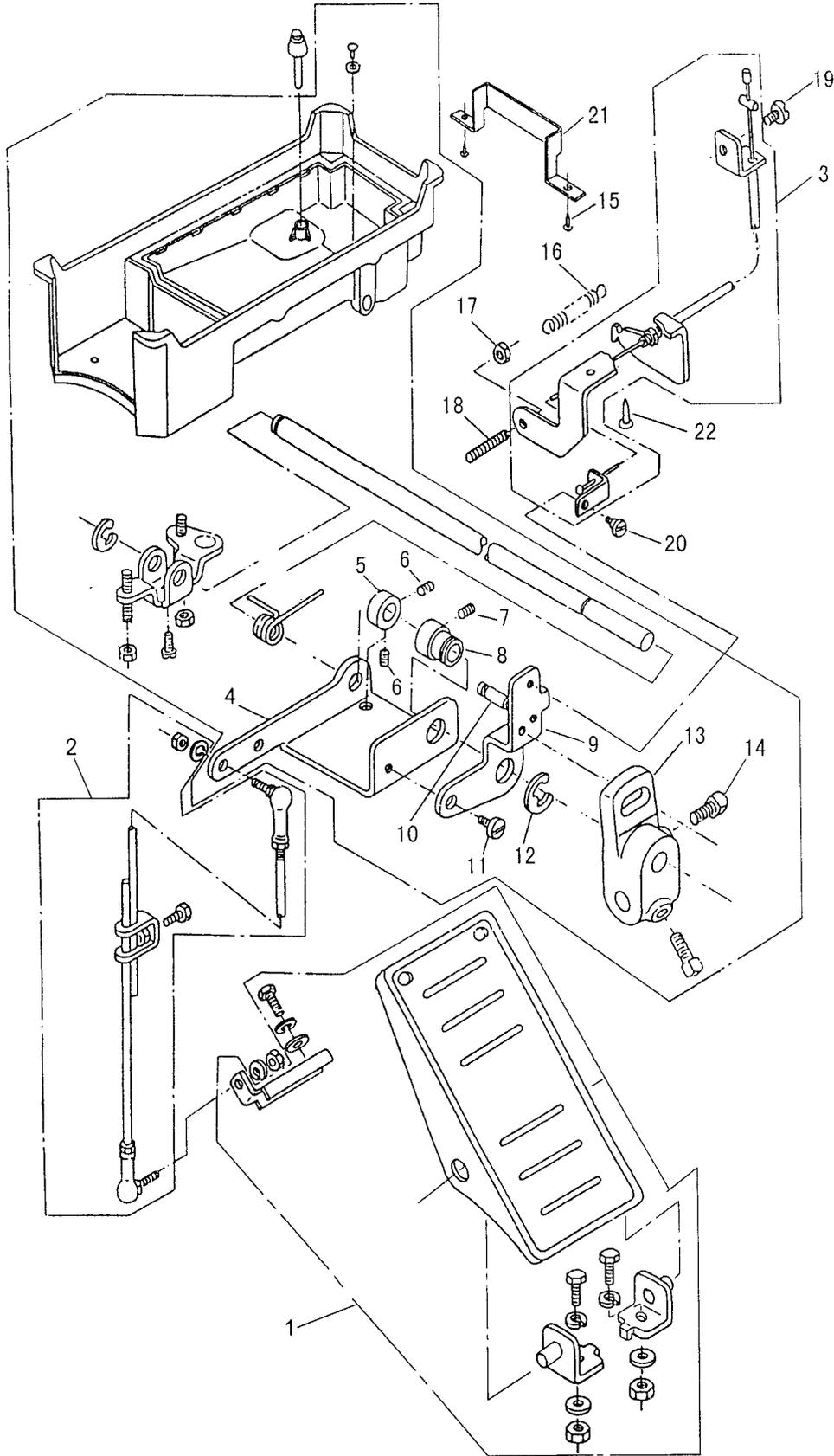

# K.INTERMITTENT RUFFLING MECHANISM

Fig. No.	Part No.	Description	GC0918-1-D	GC0918-1	Remarks
K01		Pedal assy.	1	1	
K02		Pitman rod	1	1	
K03	HD514S7101	Wire assy.	1	1	
K04	HD505S8001	Lever	1	1	
K05	H8812Q8001	Collar	1	1	
K06	HA3411D308	Set screw	2	2	15/64(28)×6
K07	HA100B2110	Set screw	2	2	11/64(40)×6
K08	HD507S8001	Collar	1	1	
K09	HD508S8001	Lever	1	1	
K10	HD509S8001	Pin	1	1	
K11	H7222F8001	Screw	1	1	1/4(40)×9
K12	H007013150	Retaining ring-E type 15	1	1	15
K13	HD511S8001	Knee lifter coupling joint	1	1	
K14	HA300J2180	Bolt	2	2	5/16(18)×13
K15	H804030160	Wood screw	2	2	
K16	HD512S8001	Spring	1	1	
K17	HA104J6510	Nut M6	1	1	15/64(28)
K18	HA104J0659	Set screw	1	1	15/64(28)×28
K19	HA100C2190	Screw	1	1	11/64(40)×6.9
K20	H6655E8001	Screw	1	1	11/64(40)×6
K21	HD513S8001	Wire protector	1	1	
K22	H801045200	Wood screw	2	2	

# L.ACCESSORIES ( I )

---

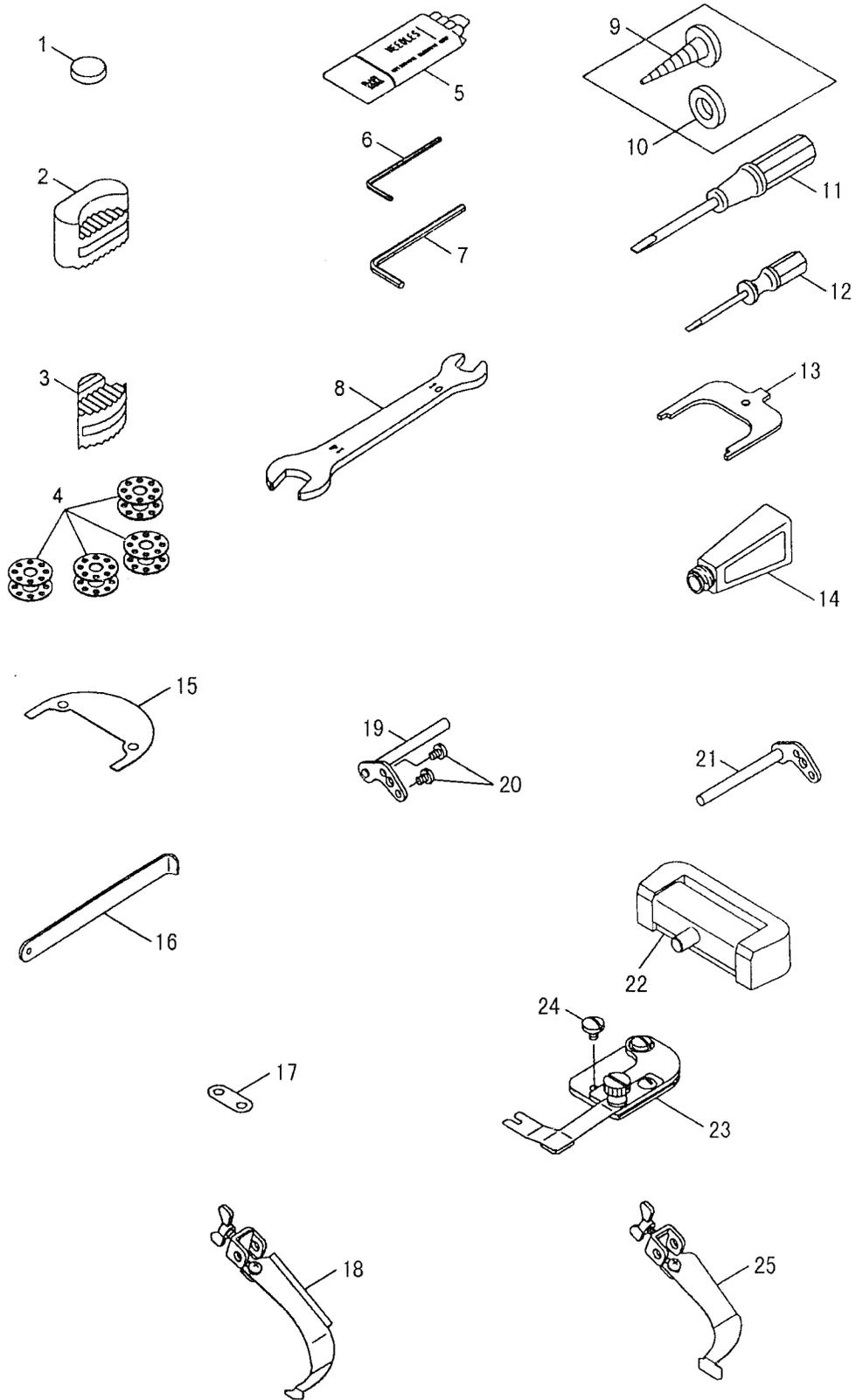

# L.ACCESSORIES ( I )

Fig. No.	Part No.	Description	GC0918-1-D	GC0918-1	Remarks
L01	HA100J2120	Magnet block	1	1	
L02	HA300J2050	Head cushion (Large)	2	2	
L03	HA300J2060	Head cushion (Small)	2	2	
L04	H2604D8001	Bobbin	4		
L04	HA100E2170	Bobbin		4	
L05	HA100C2160	Needle	4	4	DB×1-2#14
L06	HB00001020	Hexagon socket screw key 2	1		
L07	HB00001030	Hexagon socket screw key 3	1	1	
L08	HA300J2220	Spanner	1	1	
L09	H801045200	Wood screw for bobbin winder	2	2	4.5×20
L10	HA300J2230	Washer for bobbin winder	2	2	5
L11	HA300J2200	Screw driver (Middle)	1	1	
L12	HA300J2210	Screw driver (Small)	1	1	
L13	HA704S0654	Speed command disc adjusting plate	1		
L14	HA100J2110	Oil with oiler	1	1	
L15	HD519R8001	Throat plate spacer	1	1	
L16	HD552R8001	Driver plate	1	1	
L17	HD518R8001	Drop feed dog spacer	1	1	
L18	HD535R7101	Edge guide assy.	1	1	
L19	HD516R7101	Edge guide holder	1	1	
L20	HA106B0676	Screw	2	2	9/64(40)×6
L21	HD513R7101	Edge guide holder	1	1	
L22	HA307J0067	Hinge with rubber cushion	2	2	
L23	HD544R7101	Separator assy.	1	1	
L24	H32481BC21	Screw	2	2	9/64(40)×6
L25	HD542R7101	Edge guide assy.	1	1	

# L.ACCESSORIES ( II )

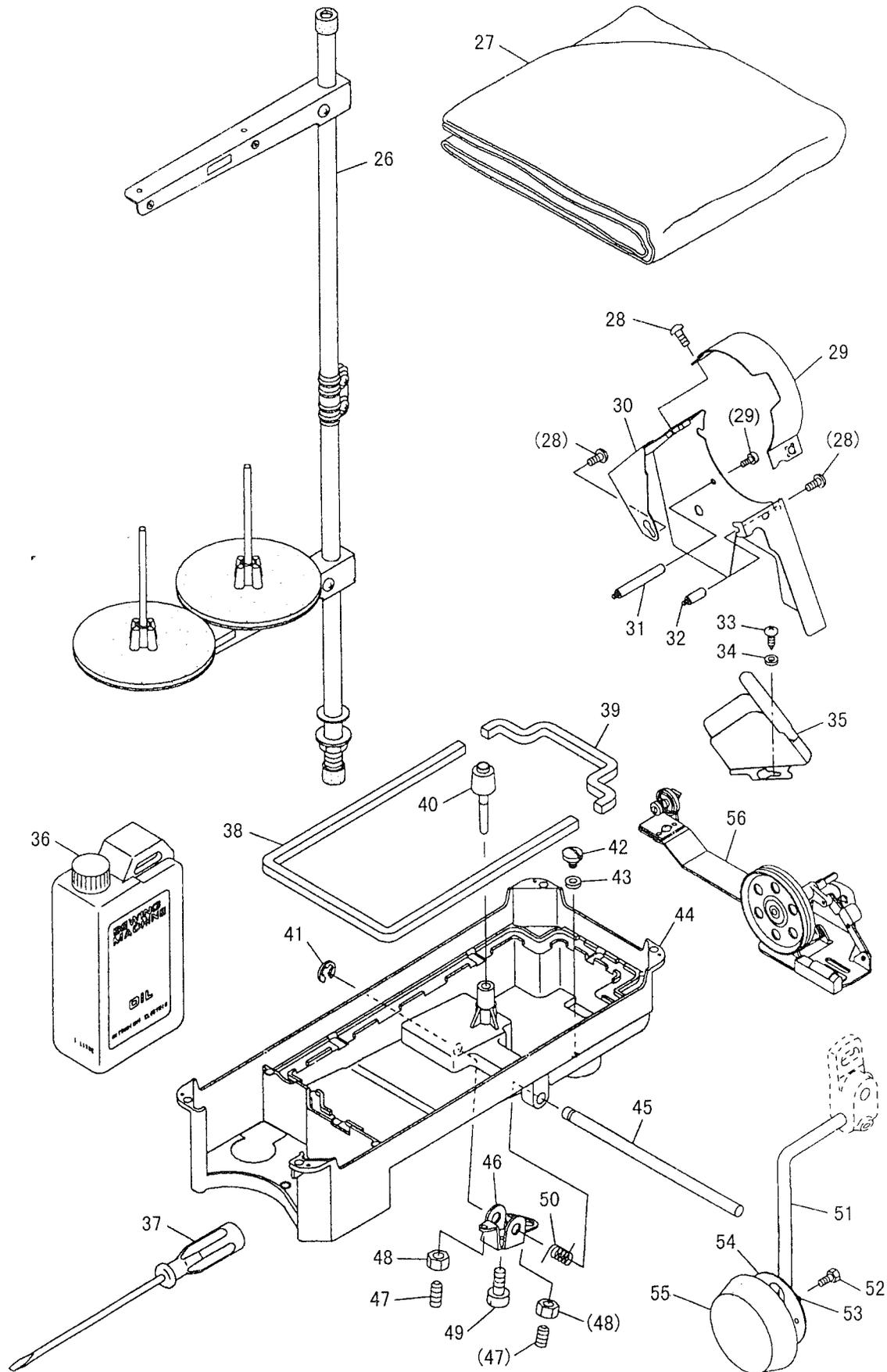

## L.ACCESSORIES ( II )

Fig. No.	Part No.	Description	GC0918-I-D	GC0918-I	Remarks
L26	HA200J2030	Thread stand assy.	1	1	
L27	HA100J2180	Vinyl cover	1	1	
L28	HA300B2170	Screw	6	6	11/64(40)×8
L29	HD526R8001	Belt cover	1	1	
L30	HD523R7101	Belt cover	1	1	
L31	HD527R8001	Stud screw	1	1	11/64(40)×6
L32	HD527R8002	Stud screw	1	1	11/64(40)×6
L33	H801045200	Wood screw	2	2	4.5×20
L34	HA300J2230	Washer	2	2	5
L35	HA305J0665	Belt cover	1	1	
L36	HA300J2170	Oil tank	1	1	
L37	HA300J2070	Screw driver (Large)	1	1	
L38	HA104J0655	Gasket for oil reservoir	1	1	
L39	HA104J0654	Gasket for oil reservoir	1	1	
L40	HA106J0661	Knee lifter lifting rod	1	1	
L41	H007013090	Retaining ring E-type	1	1	9
L42	HA104J0652	Screw	1	1	5/16(28)×10
L43	HA104J0653	Seal washer	1	1	8
L44	HA304J0651	Oil reservoir	1	1	
L45	HA300J2160	Knee lifter shaft	1	1	
L46	HA104J0658	Knee lifter	1	1	
L47	HA104J0659	Set screw	2	2	15/64(28)×27
L48	HA104J6510	Nut	2	2	15/64(28)
L49	HA110D0672	Screw	1	1	15/64(28)×14.5
L50	HA104J0657	Coil spring	1	1	
L51	HA106J0662	Knee lifter shaft	1	1	
L52	HA106J0667	Bolt	1	1	15/64(28)×8
L53	HA106J0666	Knee lifter plate stopper	1	1	
L54	HA106J0665	knee lifter Plate	1	1	
L55	HA106J0668	Knee lifter cover	1	1	
L56	HA706S0067	Bobbin winder assy.	1	1	

# GAUGES

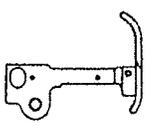
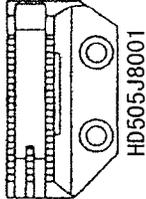
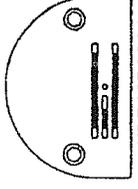
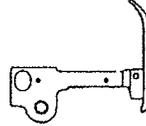
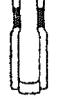
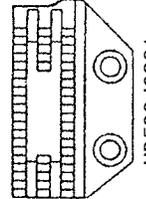
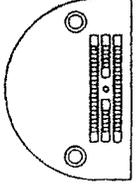
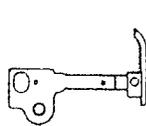
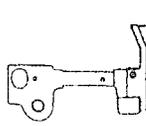
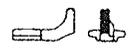
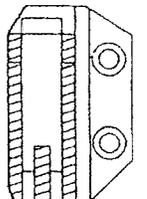
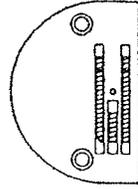
Gauge Set Type	Presser Foot	Top Feed Dog	Drop feed Dog	Throat Plate	Usage
GOM	 HD55007101	(Pusher type)  HD54908001	(p=1.15mm)  HD505J8001	Needle Hole $\phi$ 1.9mm  HD546B8001	Standard type of ruffling prevention of uneven material feed.
	 HD55807101	 HD54908001	(p=1.15mm)  HD506J8001	Needle Hole $\phi$ 1.9mm  HD554B8001	Suited for stretchy material and plushy materials.
SOM	 HD55907101	(Puller type)  HD55608001	(p=1.15mm)	Needle Hole $\phi$ 1.6mm	Various type of top-stitching, including topstitching of skirt and stacks belts. (Stitch Width:2mm)
	 HD55607101	(Puller type)  HD55708001	 HD507J8001	 HD555B8001	Edge welt seam top-stitching of men's shirts, blouses, dresses, jackets, etc. (Stitch Width:1.5mm right compensating foot)



**SHANGHAI HUIGONG NO.3 SEWING MACHINE FACTORY**

**ADD: 1418, Yishan Road, Shanghai, China**

**Zip Code: 201103**

**Overseas Business: TEL: 86-21-64853303 FAX: 86-21-64854304**

**E-mail: [highlead@online.sh.cn](mailto:highlead@online.sh.cn) <http://www.highlead.com.cn>**

The description covered in this manual is subject to change for improvement of the commodity without notice

2004.5. Printed