

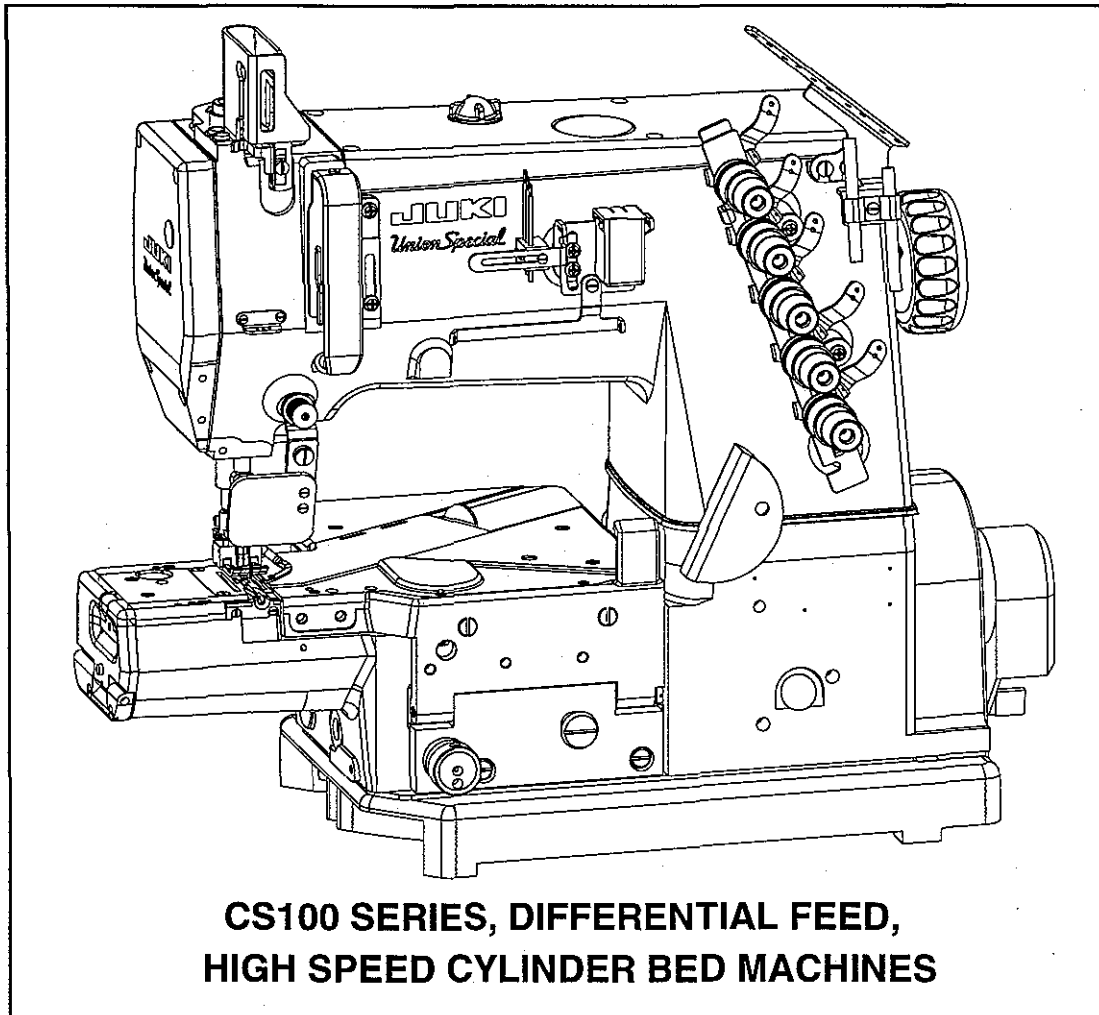

JUKI

Union Special

ILLUSTRATED PARTS SUPPLEMENT



**CS100 SERIES, DIFFERENTIAL FEED,
HIGH SPEED CYLINDER BED MACHINES**

MANUAL NO. PT9813

FOR STYLES

CS132U06

CS132C02

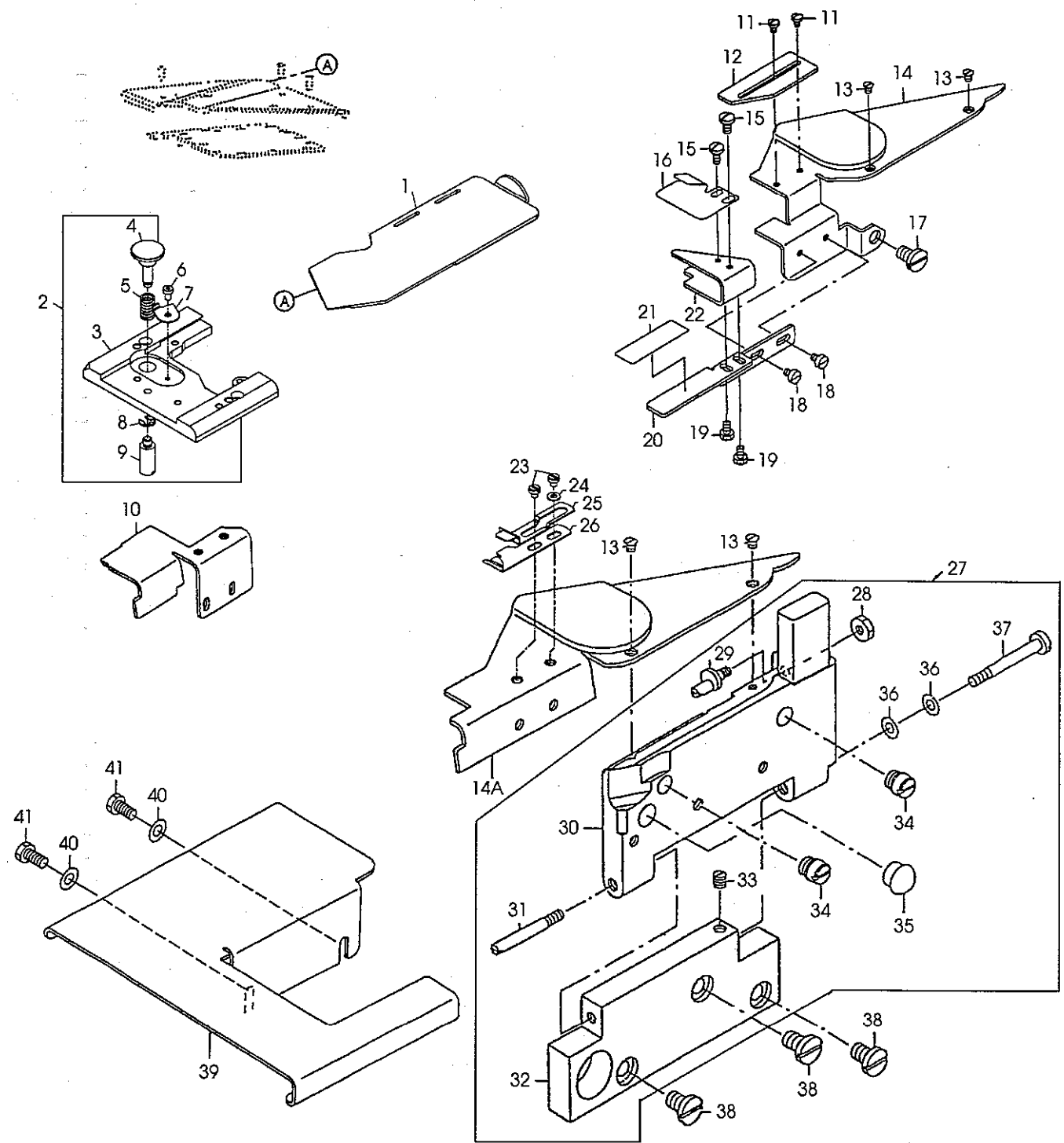

COVERS

Ref. No.	Part No.	Description	Amt. Req.
1.	50302F	Slide Cover	1
2.	29476VR	Throat Plate Support Assembly	1
3.	34380E	Throat Plate Support	1
4.	34367	Rest Bolt	1
5.	97014	Spring	1
6.	95685	Screw	1
7.	34367B	Safety Latch	1
8.	96277	Retaining Ring	1
9.	99364L	Shank Screw	1
10.	50364AD	Support Cover for C02	1
11.	22704	Screw for C02	2
12.	34764DA	Cloth Plate Extension for C02	1
13.	22766	Screw	2
14.	50301CV	Cloth Plate, Front, For C02	1
14A.	50301CW	Cloth Plate, Front, For U06	1
15.	77F	Screw for C02	2
16.	34703X	Fabric Edge Guide for C02	1
17.	22730	Screw for C02	1
18.	SS6090540SP	Screw for C02	2
19.	SS9090640SP	Screw for C02	2
20.	50383AX	Bracket for C02	1
21.	660-1108	Rubber Seat for C02	1
22.	50383AY	Edge Guide Fitting Plate	1
23.	95169	Screw for U06	2
24.	8372A	Washer for U06	1
25.	34703F3	Upper Hemmer for U06	1
26.	34703FA1	Folder, Lower for U06	1
27.	29476VS	Swing Out Cloth Plate Assembly	1
28.	9937	Nut	1
29.	99301A	Screw	1
30.	50382JV	Front Cover	1
31.	99351	Screw	1
32.	50364S	Hinge Plate	1
33.	95	Screw	1
34.	99356	Screw	2
35.	TA1100604RO	Plug	1
36.	97127	Spring Washer	2
37.	99350	Screw	1
38.	22548	Screw	3
39.	50301CU	Cloth Plate, Left for C02	1
40.	WP0651001SC	Washer for C02	2
41.	25S	Screw for C02	2



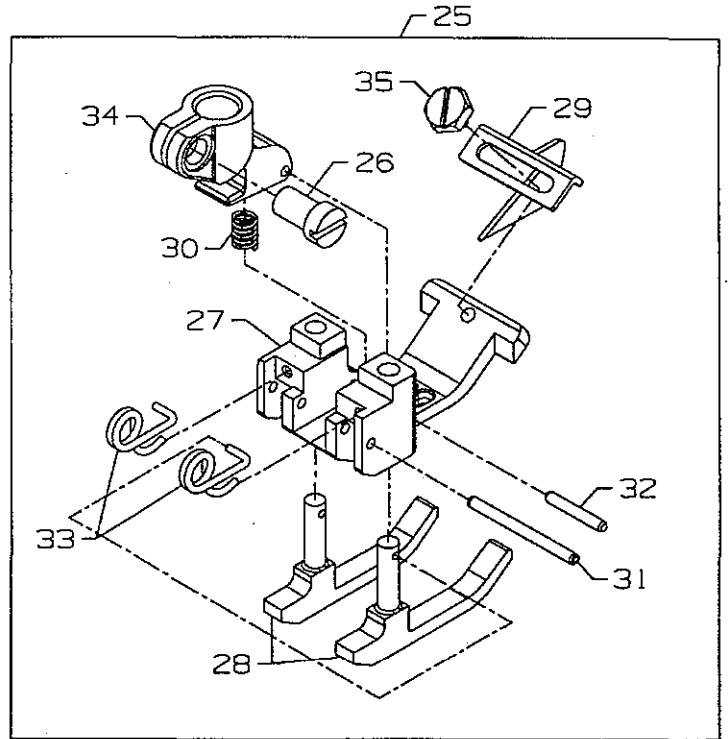
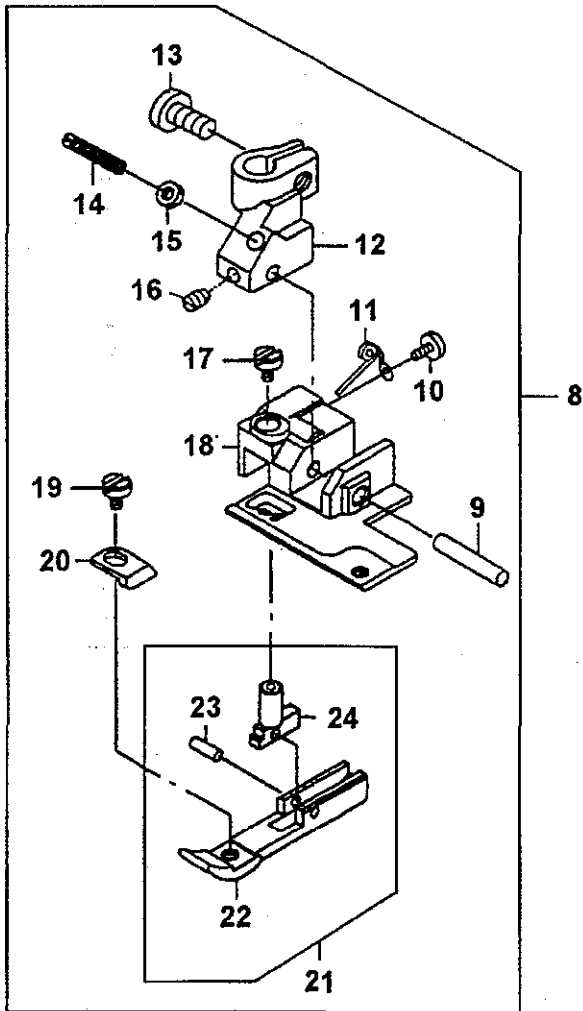
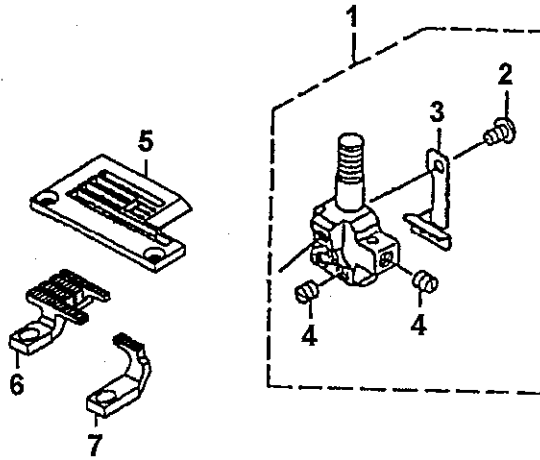
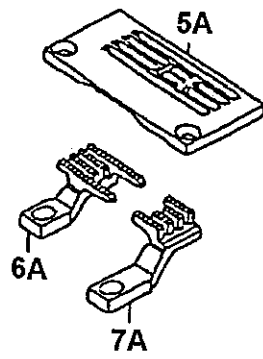

SEWING PARTS

Ref. No.	Part No.	Description	Amt. Req.
1.	-----	Needle Head (see chart)	1
2.	SS5060410SP	Screw	1
3.	50318AE56	Eyelet, Needle Head	1
4.	SS8080310TP	Screw	4
5.	-----	Throat Plate, For C02 Styles (see chart)	1
5A.	-----	Throat Plate, For U06 Styles (see chart)	1
6.	-----	Main Feed Dog, For C02 Styles (see chart)	1
6A.	-----	Main Feed Dog, For U06 Styles (see chart)	1
7.	-----	Differential Feed Dog, For C02 Styles (see chart)	1
7A.	-----	Differential Feed Dog, For U06 Styles (see chart)	1
8.	-----	Presser Foot For, C02 Styles (see chart)	1
9.	PH0300164C0	Parallel Pin	1
10.	50330FU	Screw	1
11.	50330FR	Step Presser Spring	1
12.	50330FP	Presser Foot Shank	1
13.	SM7040800SL	Screw	1
14.	18C1475	Presser Foot Stop Screw	1
15.	NM6030001SD	Nut	1
16.	SM8030500SP	Screw	1
17.	50330FS	Screw, For Step Presser Spring	1
18.	50330FM56	Presser Foot Bottom	1
19.	SM6030350SD	Screw	1
20.	50330FV	Tape Pick-up Guide	1
21.	50330FL56	Step Presser Assembly	1
22.	50330FW	Step Presser	1
23.	PH0200063C0	Pin	1
24.	50330FN	Step Presser Foot	1
25.	-----	Presser Foot, For U06 Styles (see chart)	1
26.	SS6090810TP	Screw	1
27.	50330GD56	Presser Foot Bottom	1
28.	50330GB	Yielding Section	2
29.	50330GA	Cloth Guide	1
30.	50330FF	Spring	1
31.	50330FE	Roll Pin	1
32.	50330FD	Pin	1
33.	50330FB	Spring	1
34.	50330EY	Presser Foot Shank	1
35.	18C1478	Screw	1

MODEL	NEEDLE HEAD	PRESSER FOOT ASSEMBLY	THROAT PLATE	FEED DOG MAIN	FEED DOG DIFFERENTIAL
CS132U06-3B56	50318AN56	50320CD56	50324DF56	50305BV	50326BN
CS132U06-3B64	50318AN64		50324DF64	50305CC	50326BX
CS132C02-3B56	50318AN56	50320CB56	50324AU56	50305BY	50326BS
CS132C02-3B64	50318AN64		50324AU64		



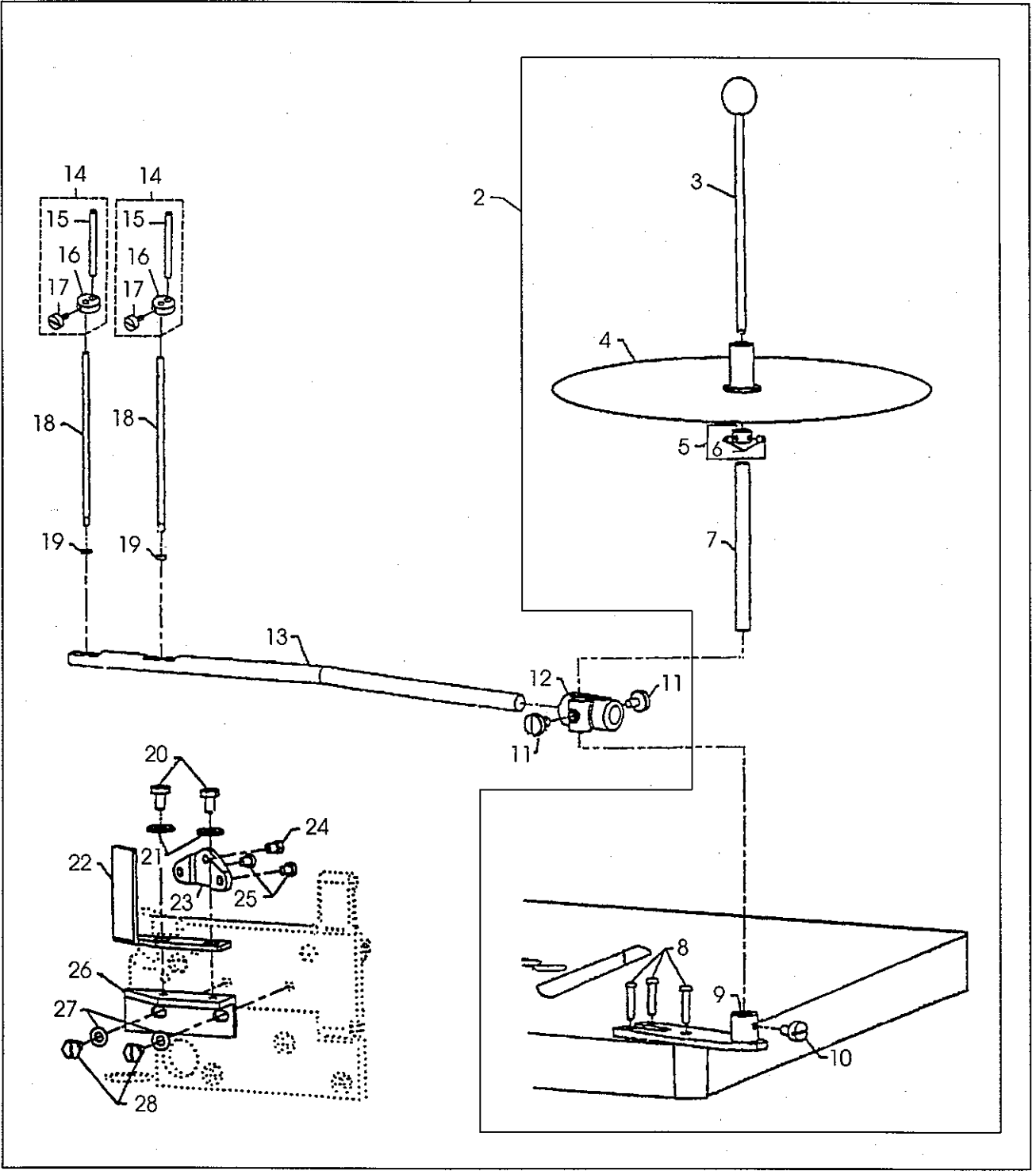

ACCESSORIES
C02 STYLES

Ref. No.	Part No.	Description	Amt. Req.
1.	29480AWY	Strip Tension Kit	1
2.	29480BBS	Tape Reel Assembly	1
3.	50322L	Support Shaft	1
4.	50392C	Tape Base Assembly	1
5.	482C	Collar	1
6.	22894C	Screw	2
7.	50322BA	Shaft	1
8.	90561K	Wood Screw	3
9.	50364A	Holder	1
10.	22728	Screw	1
11.	22728	Screw	2
12.	50392BD	Connection	1
13.	50392BE	Tape Guide Base	1
14.	50378Z	Tape Guide Assembly	2
15.	50330FZ	Tape Guide Bar	1
16.	50330BK	Tape Guide	1
17.	MAL01110000	Screw	1
18.	G50403	Tape Guide Shaft	2
19.	907	Nut	2
20.	22882	Screw	2
21.	HA20A	Washer	2
22.	34764E	Holder, Holding Plate	1
23.	23432B	Holder Clamp	1
24.	22852G	Screw	1
25.	SS7110510SP	Screw	2
26.	34764F	Holding Plate	1
27.	20	Washer	2
28.	22882	Screw	2



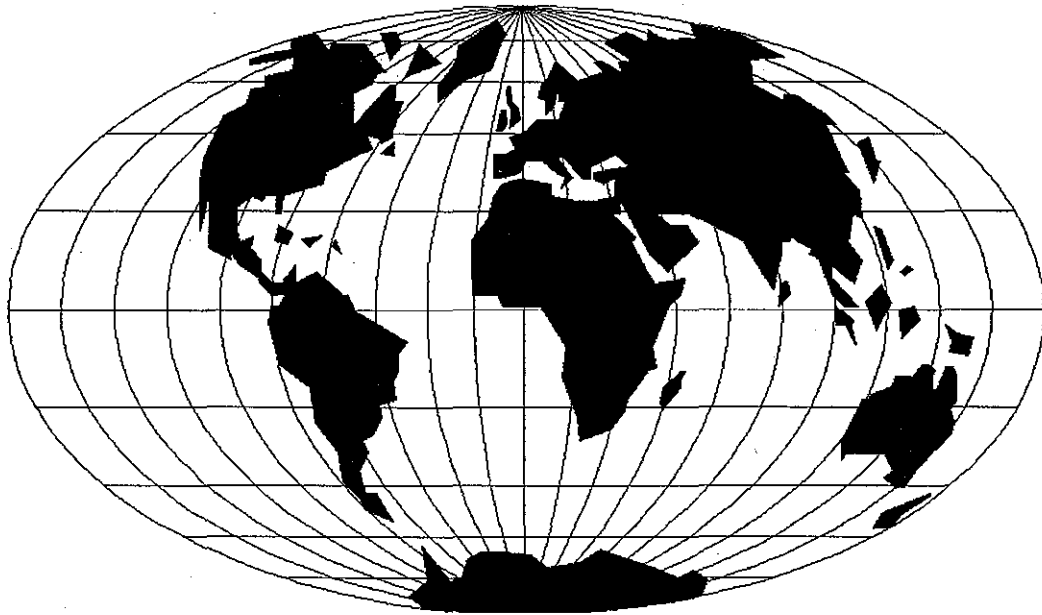

WORLDWIDE SALES AND SERVICE

Union Special Corporation maintains sales and service facilities throughout the world. These offices will aid you in the selection of the right sewing equipment for your particular operation. Union Special Corporation representatives and service technicians are factory trained and are able to serve your needs promptly and efficiently. Whatever your location, there is a qualified representative to serve you.

Corporate Office: One Union Special Plaza
Huntley, IL 60142
Phone: 847•669•5101
Fax: 847•669•4454

European Distribution Center: Union Special GmbH
Raiffeisenstrasse 3
D-71696 Möglingen, Germany
Tel: 49•07141•247•0
Fax: 49•07141•247•100

Brussels, Belgium
Charlotte, N.C.
Hong Kong, China
Huntley, IL
Leicester, England
Lille, France
Miami, FL
Milan, Italy
Möglingen, Germany
Montreal, Quebec
Osaka, Japan
Santa Fe Springs, CA
Suwanee, GA
Wayne, NJ

Other Representatives throughout all parts of the world.

Finest Quality

JUKI
Union Special