



Finest Quality

Union Special

INDUSTRIAL SEWING EQUIPMENT

ILLUSTRATED PARTS SUPPLEMENT

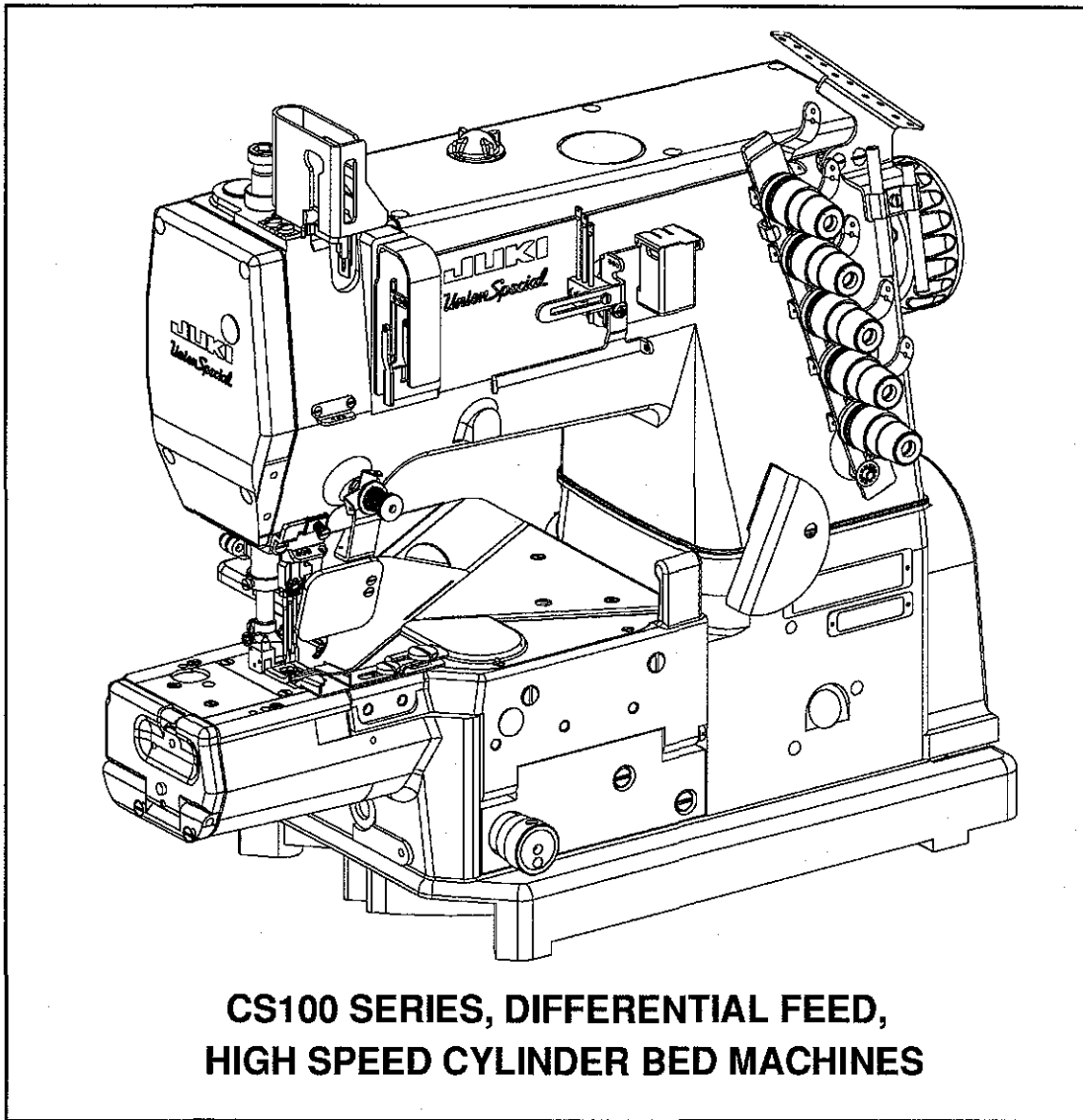

**CS100 SERIES, DIFFERENTIAL FEED,
HIGH SPEED CYLINDER BED MACHINES**

MANUAL NO. PT9609

STYLES

CS122H21

CS132H21

**Supplement PT9609
Supplement to
Manuals PT9425 & OP9637**

Fourth Edition Copyright 1997 by Union Special Corporation
Rights Reserved In All Countries Printed in U.S.A. August 1997

PREFACE

This parts supplement has been prepared to assist you in locating NEW individual parts or assemblies on the CS100 Series machines. It can be used in conjunction with Union Special Parts Manual PT9425, Operator's Manual OP9637, and Engineer's Manual EN9424.

It is the desire of Union Special that each machine run at its optimum performance. Parts listed in this manual are designed specifically for your machine and are manufactured with utmost precision to assure long lasting service.

This manual has been comprised on the basis of available information. Changes in design and/or improvements may incorporate a slight modification of configuration in illustrations or part numbers.



SAFETY RULES

1. Before putting the machines described in this manual into service, carefully read the instructions. The starting of each machine is only permitted after taking notice of the instructions and by qualified operators.

IMPORTANT! Before putting the machine into service, also read the safety rules and instructions from the motor supplier.

2. Observe the national safety rules valid for your country.
3. The sewing machines described in this instruction manual are prohibited from being put into service until it has been ascertained that the sewing units which these sewing machines will be built into, have conformed with the EC Council Directives (89/392/EEC, Annex II B).

Each machine is only allowed to be used as foreseen. The foreseen use of the particular machine is described in paragraph "STYLES OF MACHINES" of this instruction manual. Another use, going beyond the description, is not as foreseen.

4. All safety devices must be in position when the machine is ready for work or in operation. Operation of the machine without the appertaining safety devices is prohibited.
5. Wear safety glasses.
6. In case of machine conversions and changes all valid safety rules must be considered. Conversions and changes are made at your own risk.
7. The warning hints in the instructions are marked with one of these two symbols:



8. When doing the following the machine has to be disconnected from the power supply by turning off the main switch or by pulling out the main plug:
 - 8.1 When threading needle(s), looper, spreader etc.
 - 8.2 When replacing any parts such as needle(s), presser foot, throat plate, looper, spreader, feed dog, needle guard, folder, fabric guide etc.
 - 8.3 When leaving the workplace and when the workplace is unattended.
 - 8.4 When doing maintenance work.
 - 8.5 When using clutch motors without actuation lock, wait until the motor is stopped totally.
9. Maintenance, repair and conversion work (see item 8) must be done only by trained technicians or special skilled personnel under consideration of the instructions.
10. Any work on the electrical equipment must be done by an electrician or under direction and supervision of special skilled personnel.
11. Work on parts and equipment under electrical power is not permitted. Permissible exceptions are described in the applicable sections of standard sheet DIN VDE 0105.
12. Before doing maintenance and repair work on the pneumatic equipment, the machine has to be disconnected from the compressed air supply. In case of existing residual air pressure after disconnecting from compressed air supply (i.e. pneumatic equipment with air tank), the pressure has to be removed by bleeding.

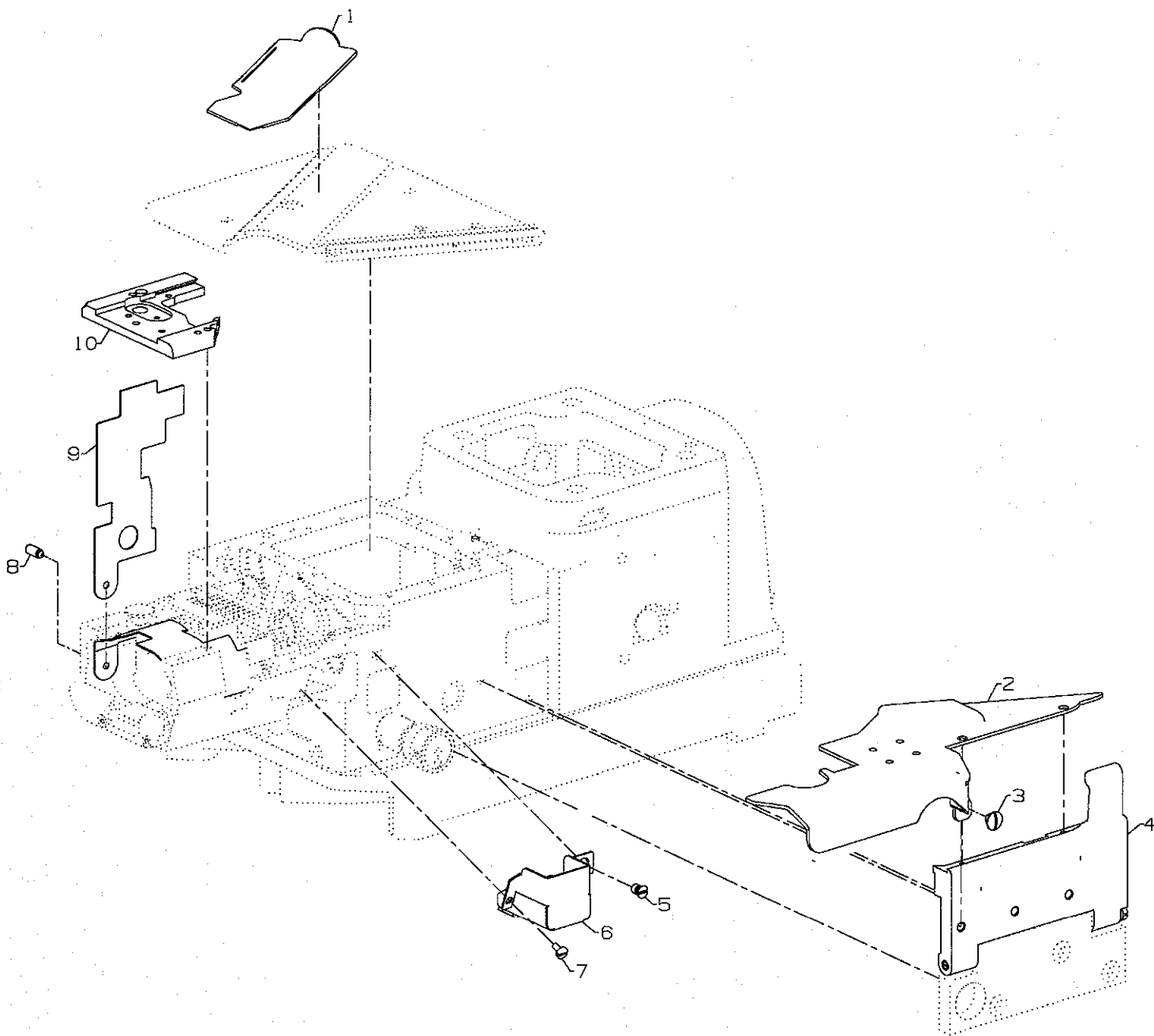

COVERS

Ref. No.	Part No.	Description	Amt. Req.
1.	50302A	Slide Cover	1
2.	50301BX	Cloth Plate, Front	1
3.	22730	Screw	1
4.	29476TA	Swing Out Cloth Plate Support	1
5.	22807	Screw	1
6.	50382JF	Guard	1
7.	98A	Screw	1
8.	22597	Screw	1
9.	50396F	Splash Guard	1
10.	34380T	Throat Plate Support	1
-	96527	Parallel Pin (not shown)	1



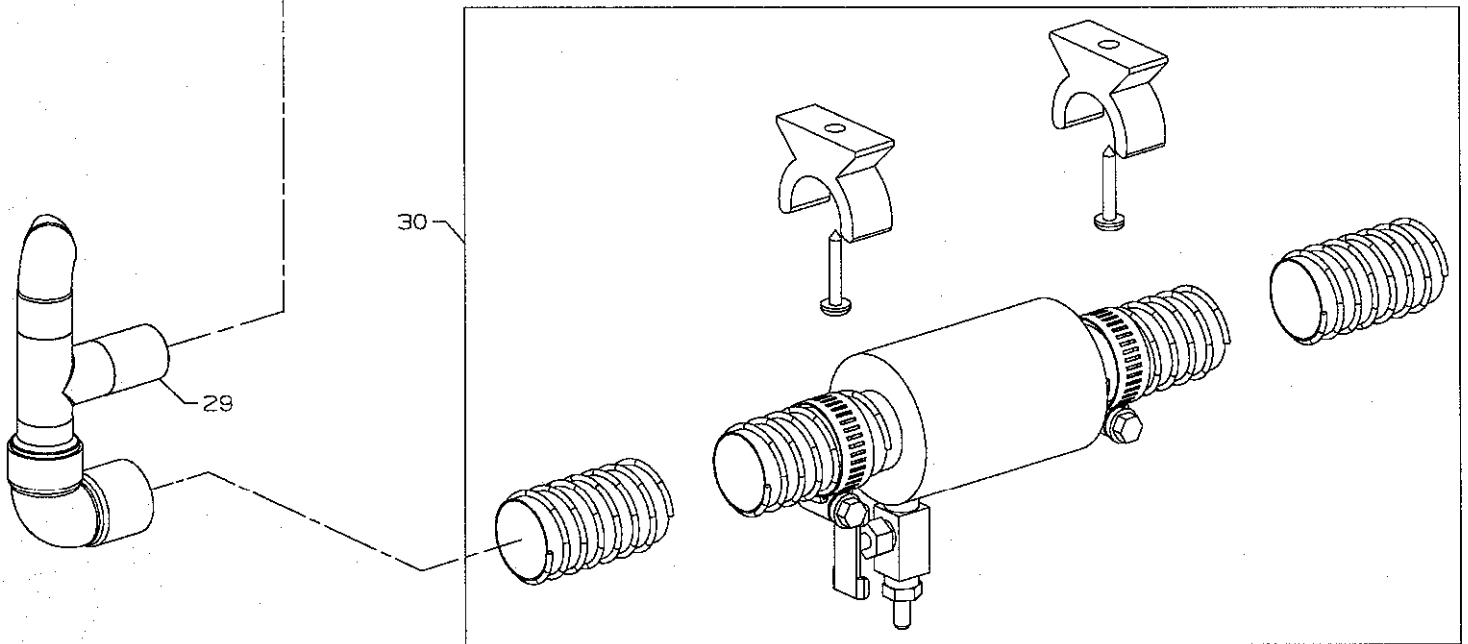
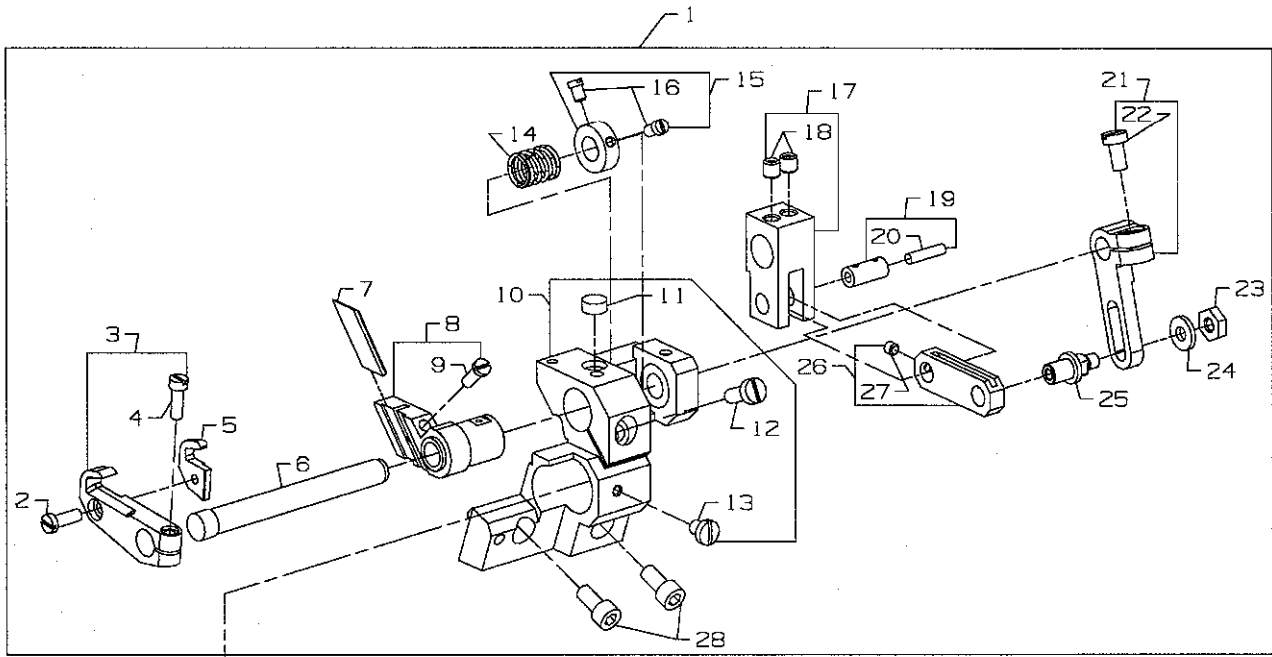

FABRIC TRIMMER ASSEMBLY

Ref. No.	Part No.	Description	Amt. Req.
1.	29924L	Fabric Trimmer Assembly	1
2.	HS24C	Screw	1
3.	34771RL	Knife Lever	1
4.	22729	Screw	1
5.	34770EL	Upper Knife	1
6.	34785L	Shaft	1
7.	34749EL	Lower Knife	1
8.	34750PL	Lower Knife Holder	1
9.	22729AB	Screw	1
10.	34739L	Support Block	1
11.	34739M	Stop	1
12.	93	Screw	1
13.	25CC	Screw	1
14.	97005D	Spring	1
15.	33688	Adjusting Collar	1
16.	22564D	Screw	2
17.	34771SL	Lever	1
18.	22894C	Screw	2
19.	34336P	Link Pin	1
20.	666-149	Oil Wick	1
21.	34771VL	Lever	1
22.	22528	Screw	1
23.	9937	Hex Nut	1
24.	4611U	Washer	1
25.	34771UL	Adjusting Bolt	1
26.	34771TL	Connecting Link	1
27.	22894Y	Set Screw	1
28.	95412	Screw	2
29.	671B115	Suction Tube	1
30.	29480AWK	Exhaust Assembly	1



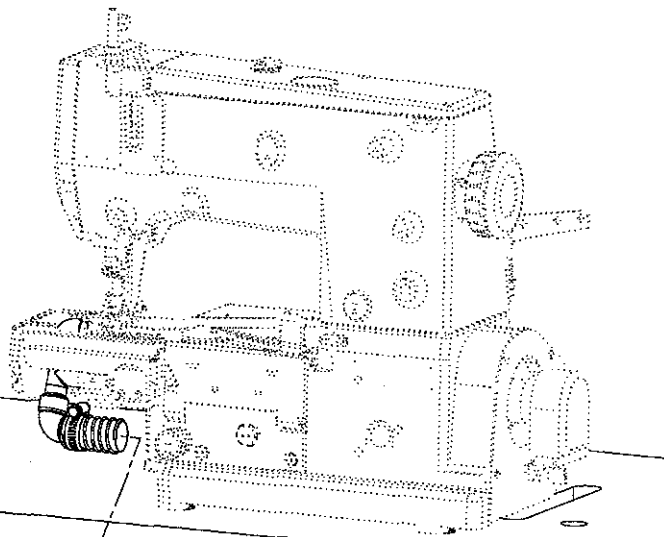

TO WASTE
CONTAINER

TUBE DIA.	TUBE
4.0 mm	H, J, K, P, Q,
1/4 in.	A, B, C, D, E, F, G

CHIP CHUTE SOLENOID { BLACK SIGNAL } TO MOTOR
 { 24V BLACK } RUN SIGNAL

DETAIL "W"

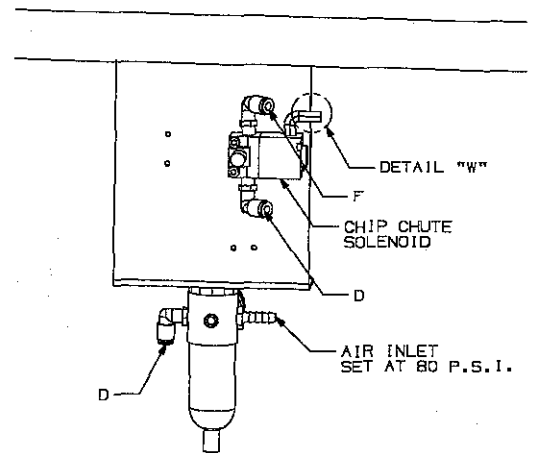

DETAIL "W"

CHIP CHUTE
SOLENOID

D

AIR INLET
SET AT 80 P.S.I.

D





ALL RIGHTS RESERVED IN ALL COUNTRIES PRINTED IN U.S.A. AUGUST 1996

CSLH21-SEWING.COM

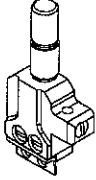
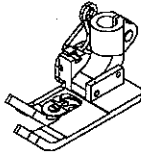
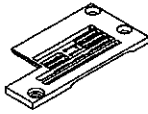
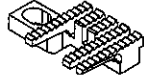
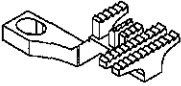
SUB CLASS	SEWING COMB.	MODEL	 NEEDLE HEAD	 PRESSER FOOT ASSEMBLY	 THROAT PLATE	 FEED DOG MAIN	 FEED DOG DIFFERENTIAL
H21	CH21-2A40	CS122H21-2A40	50318AD40	50320B640	34724FR40	34705FT	34726FT
	CH21-2C40	CS122H21-2C40			34724FT40		
	CH21-2A48	CS122H21-2A48	50318AD48		34724FR48		
	CH21-2C48	CS122H21-2C48			34724FT48		
	CH21-3A56	CS122H21-3A56	50318AD56	50320B664	34724FR56		
	CH21-3B56	CS122H21-3B56			34724FS56		
	CH21-3C56	CS122H21-3C56	50318AD64		34724FR64		
	CH21-3A64	CS122H21-3A64			34724FS64		
	CH21-3B64	CS122H21-3B64	50318AD64	34724FS84			
	CH21-3C64	CS122H21-3C64		34724FT64			
	CH21-2A40	CS132H21-2A40	50318AD40	50320B640	34724FR40		
	CH21-2C40	CS132H21-2C40	50318AD48		34724FT40		
	CH21-2A48	CS132H21-2A48			34724FR48		
	CH21-2C48	CS132H21-2C48	34724FT48				
	CH21-3A56	CS132H21-3A56	50318AD56	50320B664	34724FR56		
	CH21-3B56	CS132H21-3B56			34724FS56		
	CH21-3C56	CS132H21-3C56	50318AD64		34724FT56		
	CH21-3A64	CS132H21-3A64			34724FR64		
	CH21-3B64	CS132H21-3B64	50318AD64	34724FS64			
	CH21-3C64	CS132H21-3C64		34724FT64			



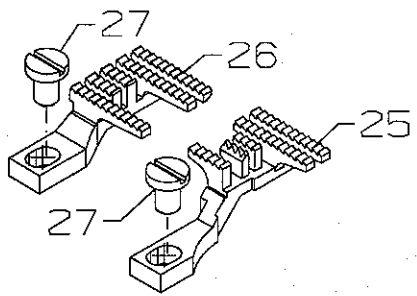
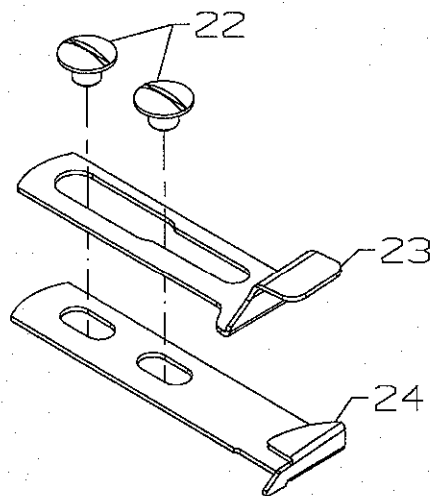
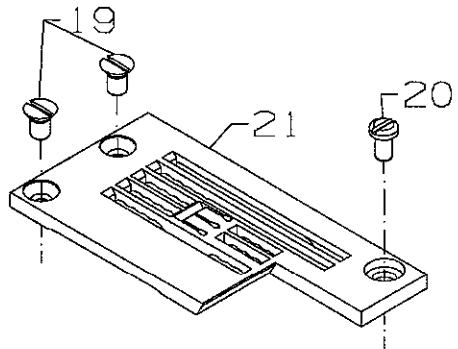
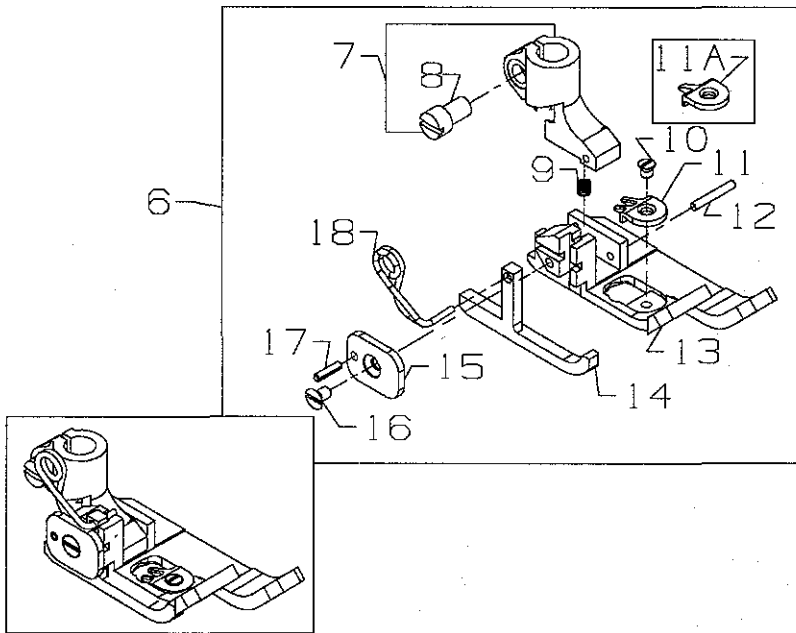
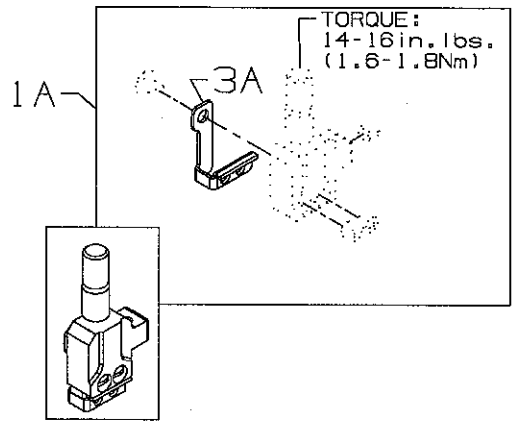
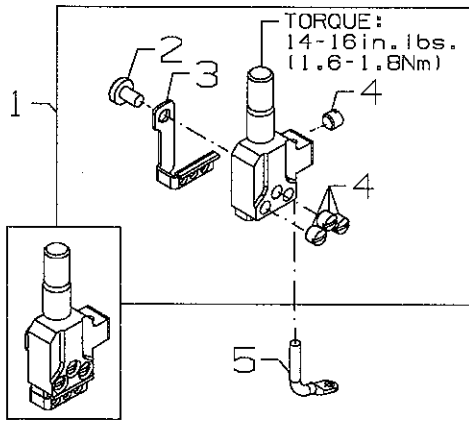

SEWING PARTS

Ref. No.	Part No.	Description	Amt. Req.
1.	50318AD64	Needle Head, for sewing comb. (see chart)	1
1A.	50318AD40	Needle Head, for sewing comb. (see chart)	1
2.	SS6066440TP	Screw	1
3.	50318AE56	Eyelet	1
3A.	50318AE40	Eyelet	1
4.	SS8080310TP	Screw	3/4
5.	50392G	Needle Thread Eyelet	1
6.	-----	Presser Foot Assembly, for sewing comb. (see chart)	1
7.	G57730GB	Presser Foot Shank	1
8.	91	Screw	1
9.	39568J	Spring	1
10.	22716A	Screw	1
11.	50397A16	Stitch Tongue	1
11A.	50397C	Stitch Tongue	1
12.	6-25-1.5mm	Drill Rod	1
13.	50330DU64	Presser Foot Bottom	1
14.	34730AT	Yielding Section	1
15.	G57730GC	Plate	1
16.	22716	Screw	1
17.	96651	Roll Pin	1
18.	G57730GD	Spring	1
19.	87	Screw, for throat plate	3
20.	22768	Screw, for throat plate	1
21.	-----	Throat Plate, for sewing comb. (see chart)	1
22.	22730	Screw	1
23.	34703F2	Hemming Guide	1
24.	34703FT	Hemmer	1
25.	34726FT	Differential Feed Dog	1
26.	34705FT	Main Feed Dog	1
27.	99293	Screw, for feed dogs	2



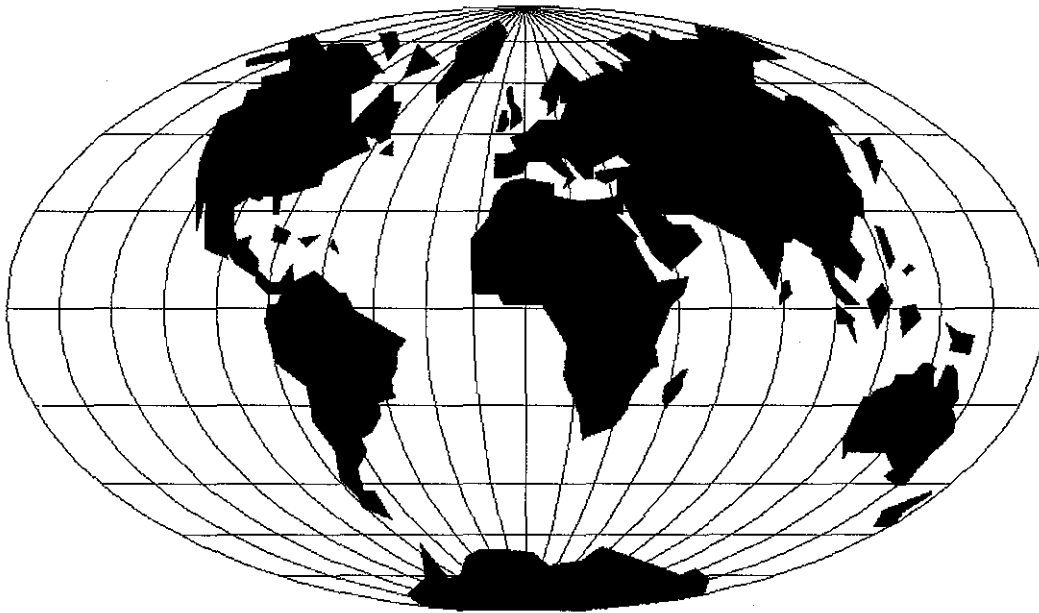

WORLDWIDE SALES AND SERVICE

Union Special Corporation maintains sales and service facilities throughout the world. These offices will aid you in the selection of the right sewing equipment for your particular operation. Union Special Corporation representatives and service technicians are factory trained and are able to serve your needs promptly and efficiently. Whatever your location, there is a qualified representative to serve you.

Corporate Office: One Union Special Plaza
Huntley, IL 60142
Phone: 847•669•5101
Fax: 847•669•4454

European Distribution Center: Union Special GmbH
Raiffeisenstrasse 3
D-71696 Möglingen, Germany
Tel: 49•07141•247•0
Fax: 49•07141•247•100

Brussels, Belgium
Charlotte, N.C.
El Paso, TX
Hong Kong, China
Huntley, IL
Leicester, England
Lille, France
Miami, FL
Milan, Italy
Möglingen, Germany
Montreal, Quebec
Osaka, Japan
Santa Fe Springs, CA

Other Representatives throughout
all parts of the world.



Union Special
INDUSTRIAL SEWING EQUIPMENT